

namco®



Installation and Commissioning Manual

IT IS THE RESPONSIBILITY OF THE OPERATOR TO MAINTAIN CUSTOMER
SAFETY AT ALL TIMES, AND IT IS IMPERATIVE THAT THE DETAILS SET OUT
IN THIS MANUAL ARE FOLLOWED PRECISELY,

SAFETY WARNING

In order to use this machine safely, be sure to read this Installation and Commissioning manual and the Operators Manual carefully before installation, adjustment or use of this machine.

Whenever the owner of this machine entrusts disassembly, installation, adjustment, routine maintenance or trouble shooting to another person, the owner should ensure that that person read the appropriate precautions and relevant sections of this manual before starting work.

In order that no accidents occur when the machine is in operation, strictly follow the notes on safety described below.

Do not turn this machine ON until it has been correctly installed.

Warnings for Operation (Ⓒ Ⓔ Requirements)

- NOTE:* Only operate this machine after checking that it has been installed correctly and in accordance with this manual.
- NOTE:* Parts of this machine move during game play, so there are places where the distance between the stationary section and moveable section changes. There are warning notices to keep hands and feet clear of moving parts, however if the operator feels that a person is in any danger, he should warn that person accordingly.
- NOTE:* The warning notices must always be kept in good condition and replaced if worn, so that the customer can read it clearly.
- NOTE:* **If there is an error or problem with this machine, operation must be stopped immediately and the problem rectified before further use.**
- NOTE:* Installation, service, adjustments and routine maintenance should be carried out by qualified personnel only.

Warnings for Disassembly, Installation, Routine Maintenance, and Troubleshooting.

- DANGER:* Namco Ltd. bears absolutely no responsibility for accidents or injuries resulting from unauthorized changes to this machine.
- DANGER:* Ensure that the machine has been turned **OFF** before making adjustments or carrying out maintenance. Also ensure only qualified personnel carry out maintenance or turn the power **ON** to this machine.
- DANGER:* The power supply and inside the monitor will remain hot and have areas of high voltage even though the machine has been turned OFF, and there is a possibility of burns or electric shock. Be careful not to touch these areas.
- DANGER:* In order to avoid injuries due to mis-operation, be sure that the voltage of the main power supply is within the prescribed limits. Also to prevent possible electric shocks due to failure, this machine **MUST** be fitted with a securely connected earthed plug.
- NOTE:* Do not turn the power switch **ON** until the machine has been installed correctly.

2. INSTALLATION

Notes on Installation

DANGER: NEVER turn the power to the machine ON until installation has been completed.

DANGER: In order to avoid injury or damage to the machine due to mis-operation, ensure that the voltage of the mains is 220-240volt AC. Also, in order to prevent possible electric shocks, be sure that the machine is connected to the mains supply with a securely connected earthed plug.

WARNING If the location site of this machine has a polished floor it is recommended that rubber pads are fitted under the level adjusters to prevent the machine sliding on the floor.

NOTE: So that customers are not injured by the movement of the Ski Tray, ensure that there is at least 300mm separation between other machines or walls.
If two Alpine Racer machines are next to each other the space between them must be at least 600mm.

NOTE: In order to gain access to the Power Supply and CPU assemblies, make sure that the rear of the machine is separated from a wall or other machine by at least 500mm.

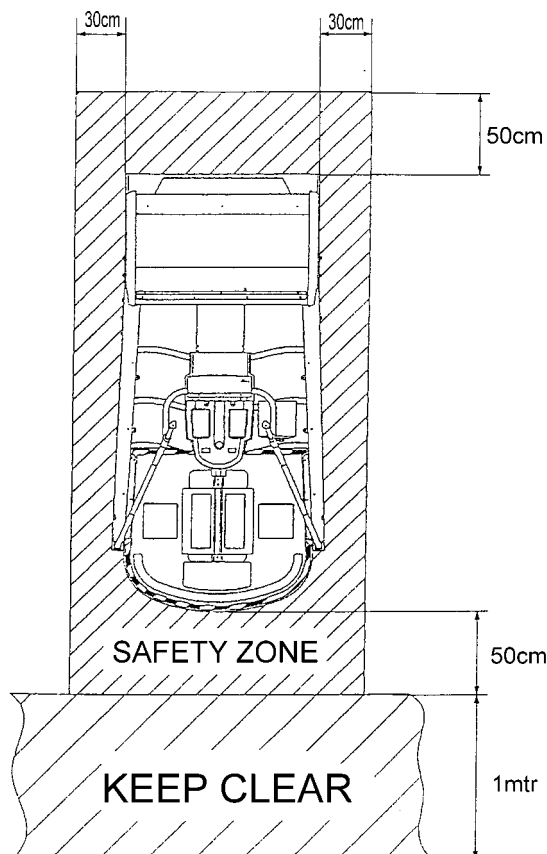

This machine is designed for indoor use only. **Do Not** install the machine in any of the following places.

① Outdoors.

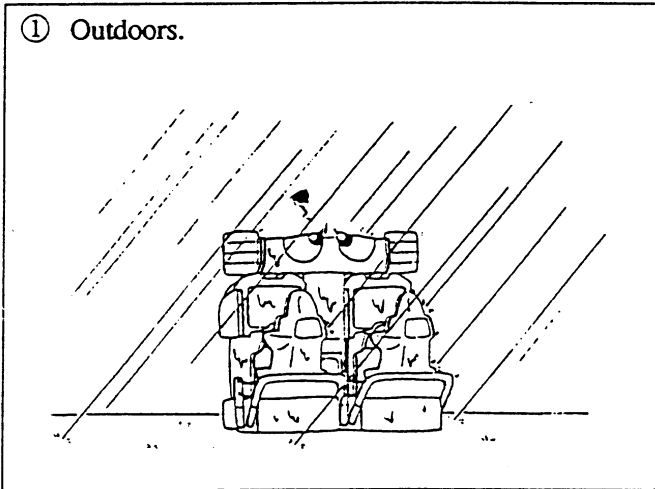

② Direct sunlight, places with excessive humidity or dust, places where there is water leakage, near air-conditioning or heating equipment, places with excessively high or cold temperature.

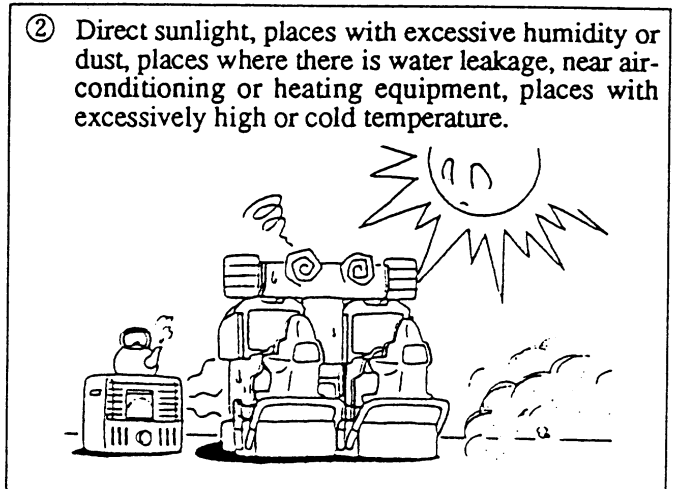

③ Places where it would be in the way of emergency exits or fire extinguishing equipment.

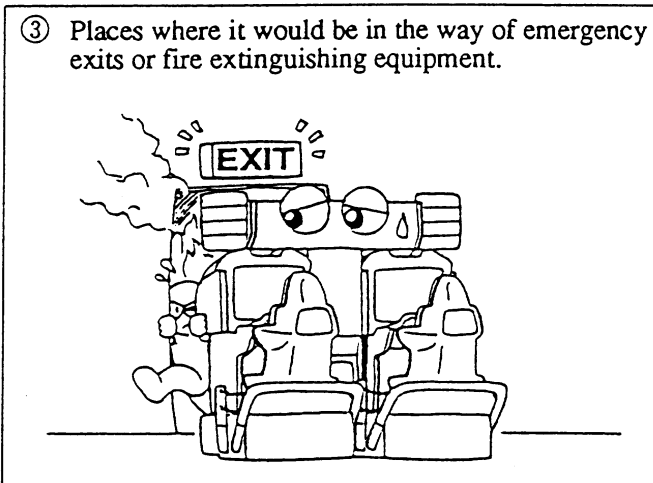

④ Unstable places or places with excessive vibration.

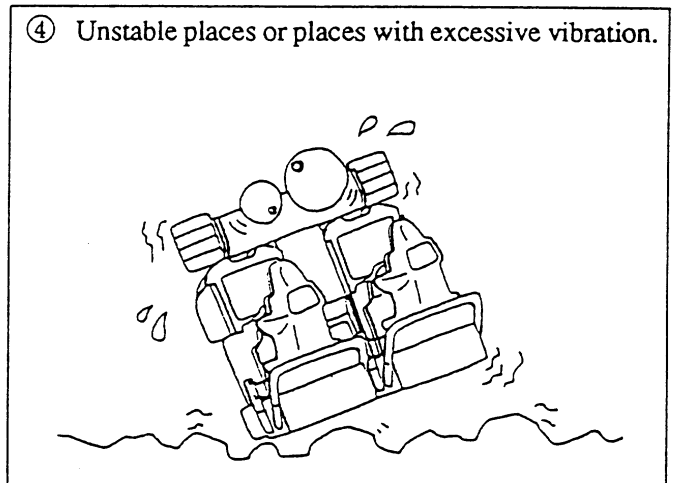

⑤ Places that are not level.

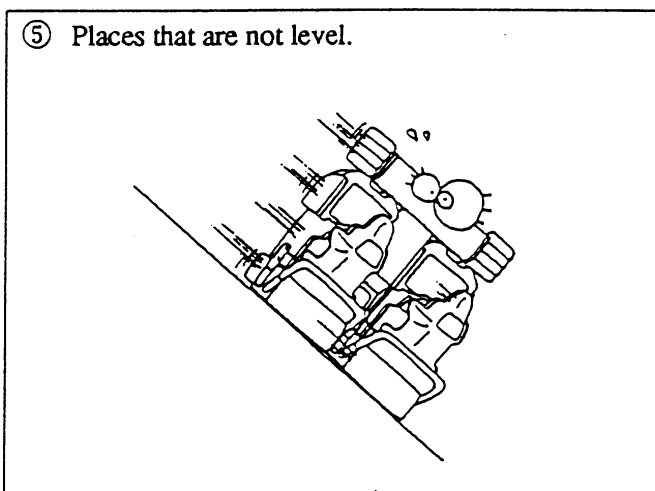

Safety Mechanisms and Controls

For safety, this machine is equipped with a locking mechanism for securing the steps when the machine is not being played.

- The step locking mechanism is controlled as describe below.
 - a. After selecting the course, the step lock is released before game start.
 - b. At game over, the steps are locked.
 - c. If the steps are moved left or right while they are locking or unlocking, the motor temporarily stops in order to prevent damage to the step-lock motor. When the steps are no longer being moved left or right, the motor will restart. To prevent damage from occurring, do not move the steps while the motor is running.
 - d. When the machine is first turned ON, the step-lock mechanism is checked automatically by unlocking and re-locking the steps.
 - e. If the step-locking system fails, an error message will be displayed on the monitor screen.

[Refer to section 4-3 "Handling Motor Errors" \(Page 23\)](#)

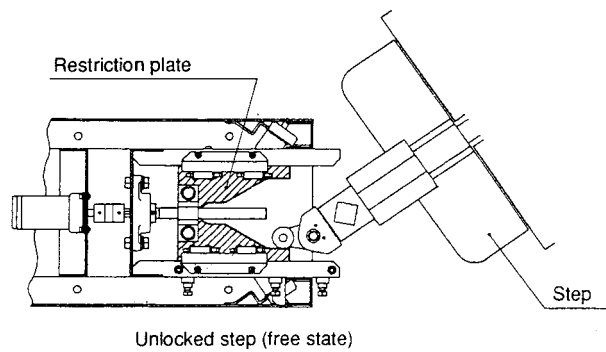
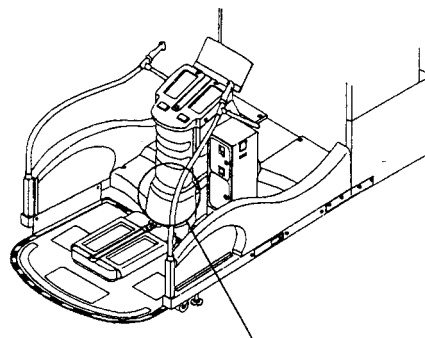

The restriction plate moves to the side of the steps and locks the steps.

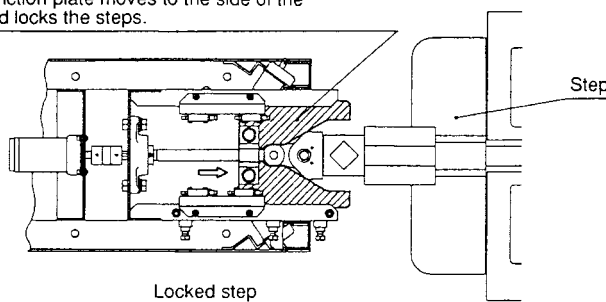

2-1 Fitting the Header Assembly

The Header Assembly has a forward centre of gravity, so it is important that at least two people are used to fit or remove the Header Assembly.

The fitting position of the Header Assembly is very high, and it is important that a means of reaching the height safely, without stretching, is available. (e.g. steps, step stools etc.)

1. Place the Header Assembly on to the monitor cabinet, connect the connectors and pass the connectors in to the cabinet, slide the header back ensuring that it engages fully in to the retaining brackets at the front of the monitor cabinet.
2. Fit the 2 off M6x25 Hex Head Screws, Spring and Flat washers to retain the Header Assembly to the cabinet.

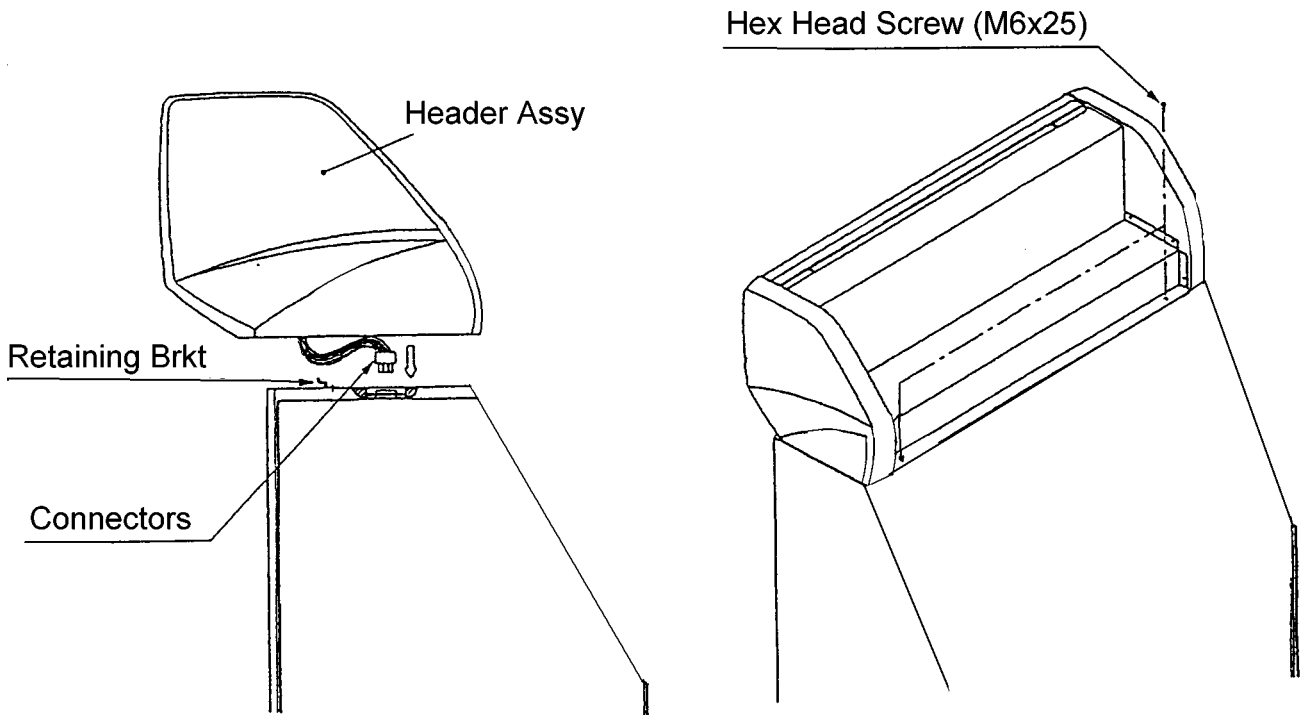

2-2 Connecting the Ski Assy to the Monitor Cabinet.

1. Connect the connectors between the Ski Assembly and Monitor Cabinet.
2. Push the Ski Assembly fully up to the monitor cabinet, taking care not to trap any wires.
3. Fit, finger tight, a joint bracket to each side using 4 off Hex Head Set Screws (M10x25), Spring and Flat Washers on each bracket. Tighten fully all screws.

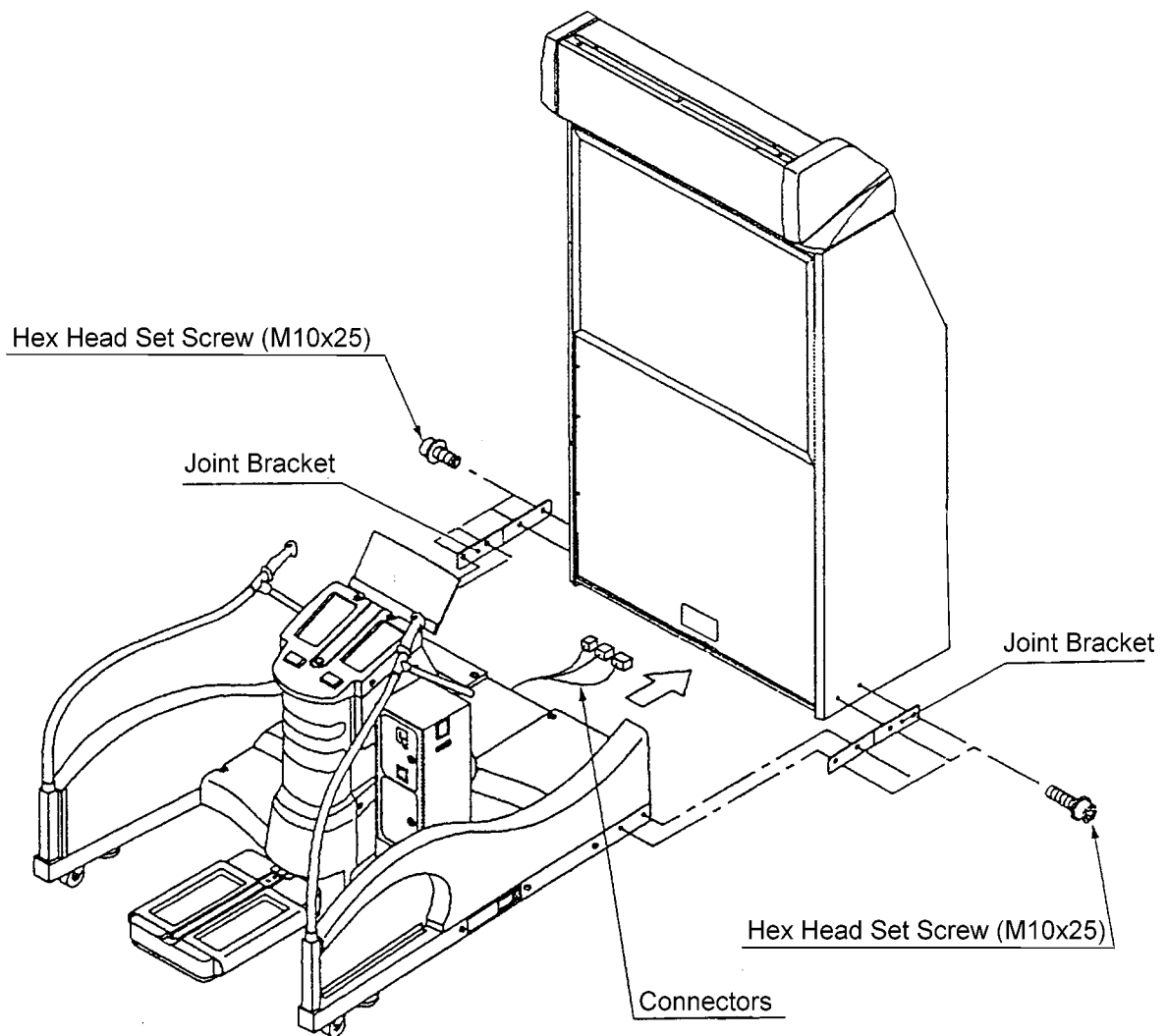

NOTE:-

When the machine is fully assembled and in its final position, lower the 10 level adjusters, (4 on the monitor cabinet and 6 on the ski assy (especially the two in front of the step assy)), with a spanner so that all castors are raised from the floor, and the machine is level.

Tighten the lock nuts with a spanner to ensure that the level adjusters do not move.



If this machine is installed on a smooth or shiny floor it is recommended that rubber slip mats be placed under the feet to prevent the machine moving during game operation.

2-3 Fitting the Safety Mat

1. Assemble the Floor Safety Mat by fitting the securing plates from underneath, the support brackets from the top and retaining the assembly together with the M6 Dome Nuts.
2. Place the assembled Safety Mat into position under the Ski Step Assy.
3. Retain the Safety Mat in position with the Hex Head Set Screws (M8x20)

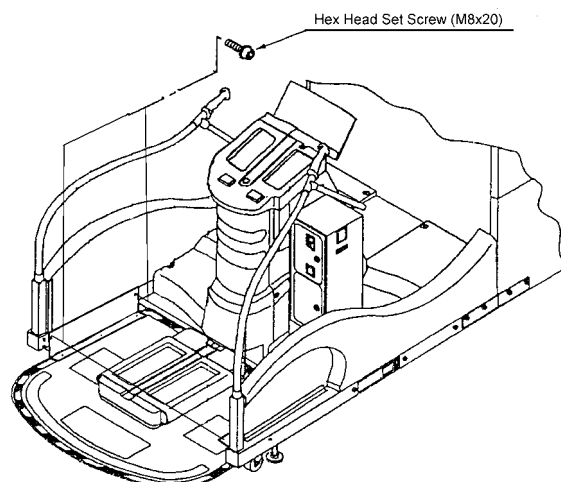
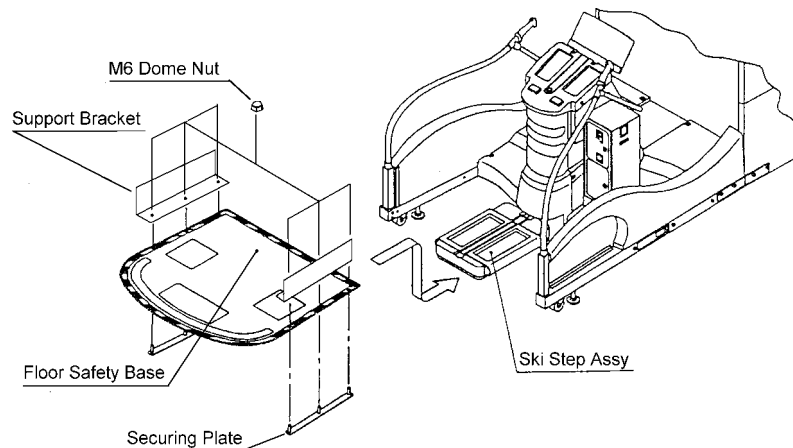

3. ADJUSTMENTS

3-1 Turning on the Power

After the machine has been installed, turn ON the power. The power switch is located on the rear of the monitor cabinet.

3-2 Adjustment Switches

The Adjustment switches are located inside the coin door.

1. Service Switch.
Press this switch to obtain game credits without incrementing the play meter.
2. Test Switch
Slide the test switch ON to enter test mode.
Test mode allows testing and the changing of game settings. (Refer to [section 3-3](#) "Test Mode" (page 9))

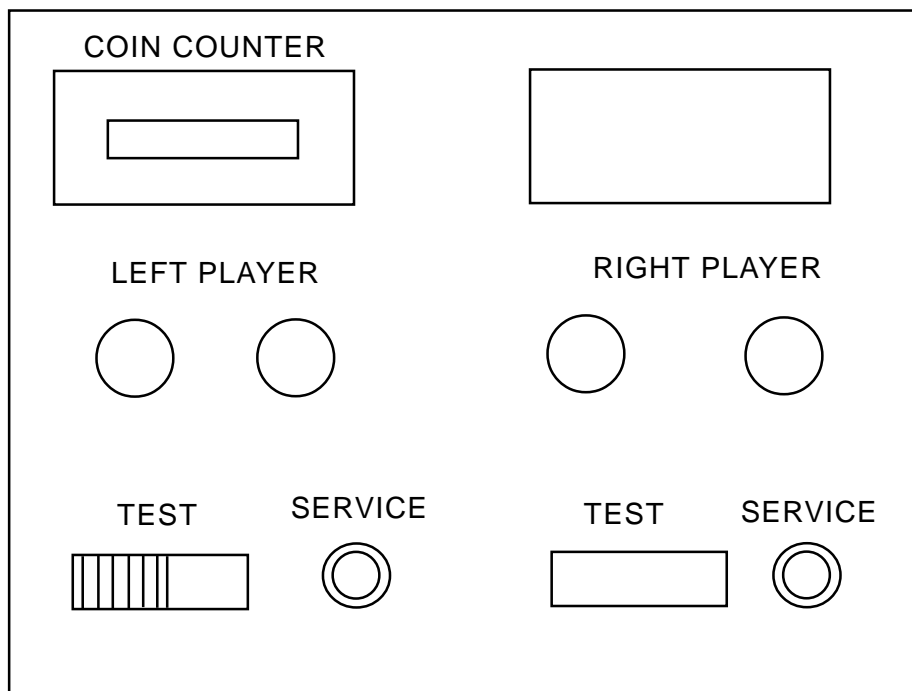

Service Bracket

3-3 Test Mode

1. Open the coin door and slide the test switch "ON". The menu screen will be displayed on the monitor.
2. Select the test required by pressing the 'Left or Right Selection' push button. The selected test will 'blink'.
3. Enter the selected test by pressing the 'Decision' push button. Select "EXIT" to return the "Menu Screen".
4. After testing is completed, ensure that the test switch is returned to the "OFF" position to return to normal game mode.

The Test Switch must always be in the "OFF" position for normal game mode.

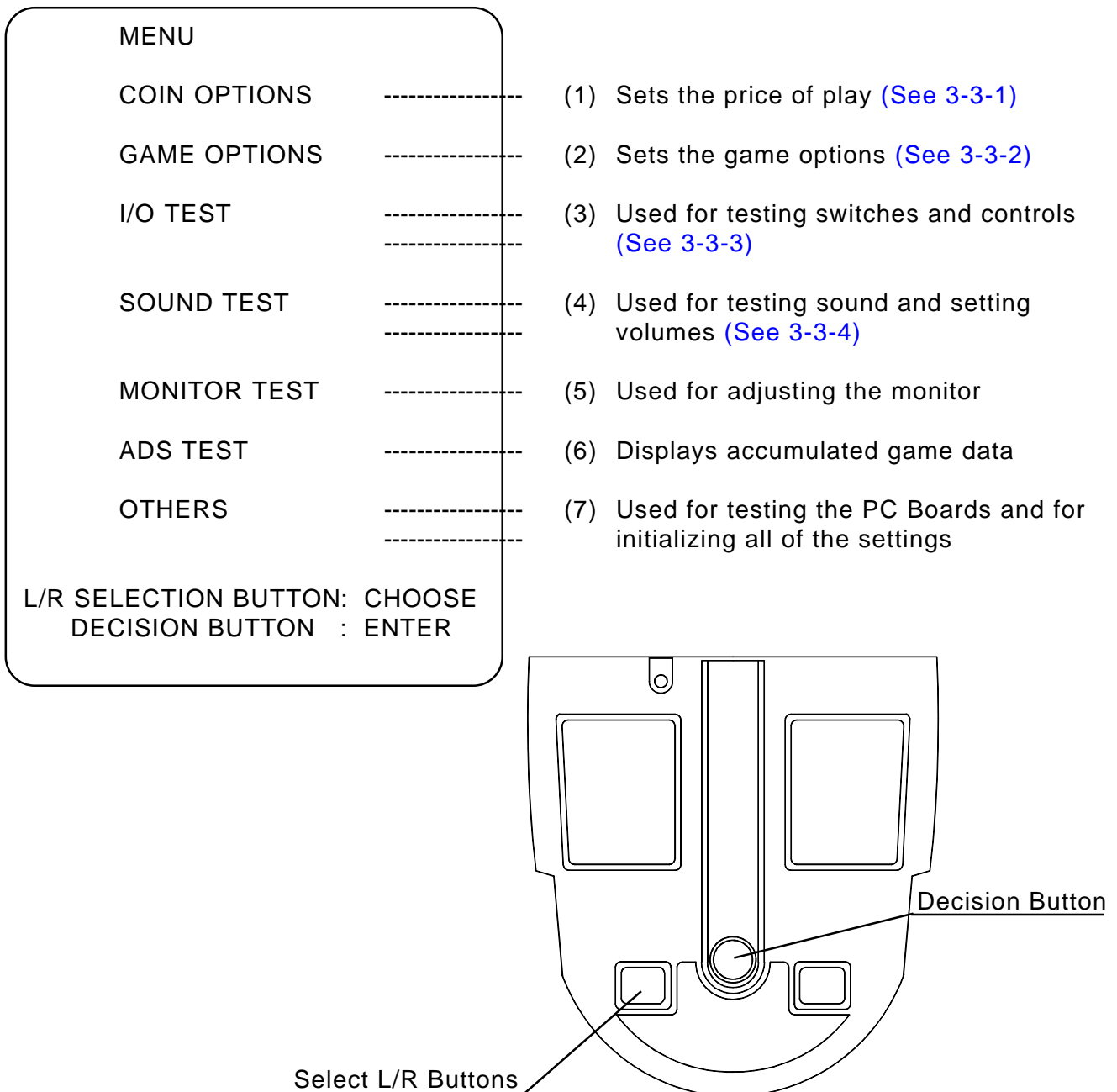

3-3-1 Coin Options

1. Select item (1) "COIN OPTIONS" on the menu screen to set the game cost and related settings.
2. Press 'Select L/R' to select the required item.
3. Use the 'Decision' button to adjust the settings.
4. Select "EXIT" to return to the menu screen.

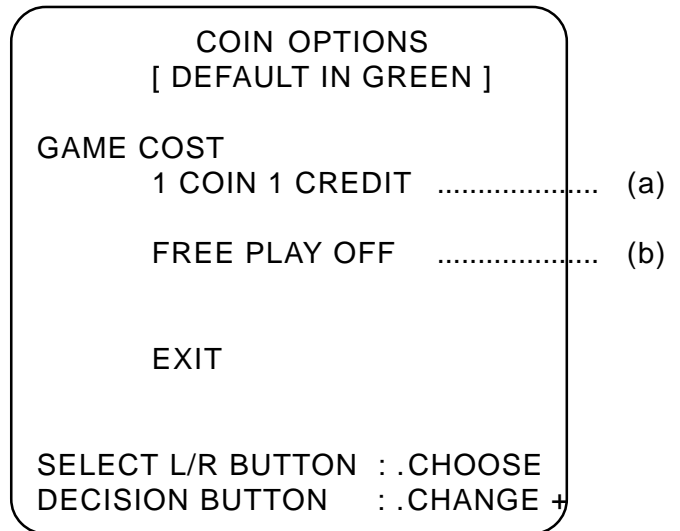

Note :- The price of play on this machine is set within the Cashflow Coin Mech. Ensure that the Coin Options on the screen are set as shown in the following table.

ITEM	CONTENTS	FACTORY SET
(a) Game Cost	No of Coins required for No. of credits - - - - - settable 1 - 9	1 Coin 1 Credit
(b) Free Play	Yes/No	NO

3-3-2 Game Options

1. Select item (2) "GAME OPTIONS" on the menu screen to set the game options and related settings.
2. Press 'Select L/R' to select the required item.
3. Press the 'Decision' button to adjust the settings. Standard settings are displayed in green.
4. Select "EXIT" and press 'Decision' to return to the menu screen.

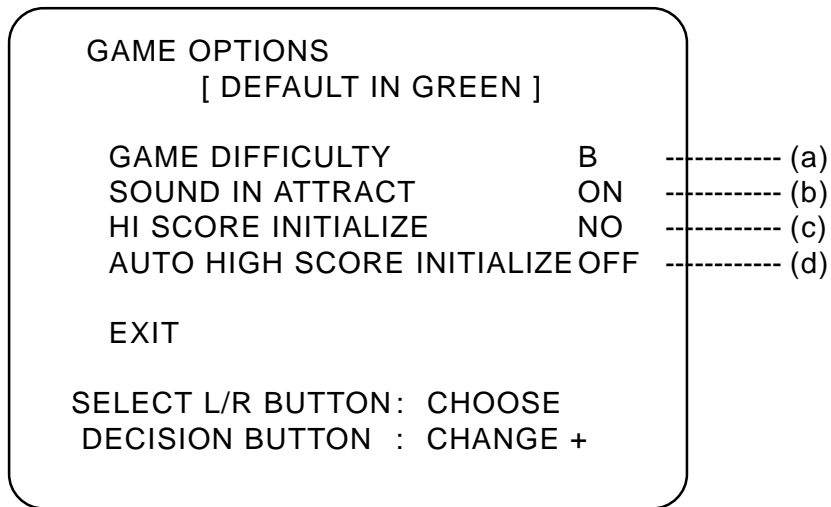

ITEM	DESCRIPTION	FACTORY SET
(a) Game Difficulty	A (easy) to C (hard)	B
(b) Sound in Attract	On / Off	On
(c) Hi Score Initialize	Yes / No	No
(d) Auto High Score Initialize	On / Off	Off

3-3-3 I/O Test

1. Select item (3) "I/O Test" on the menu screen to test the switches, motor and step adjust.
2. Press 'Select L/R't to select the required item, then press the 'Decision' button to enter the test.
3. Select "EXIT" and press the 'Decision' button to return to the menu screen.

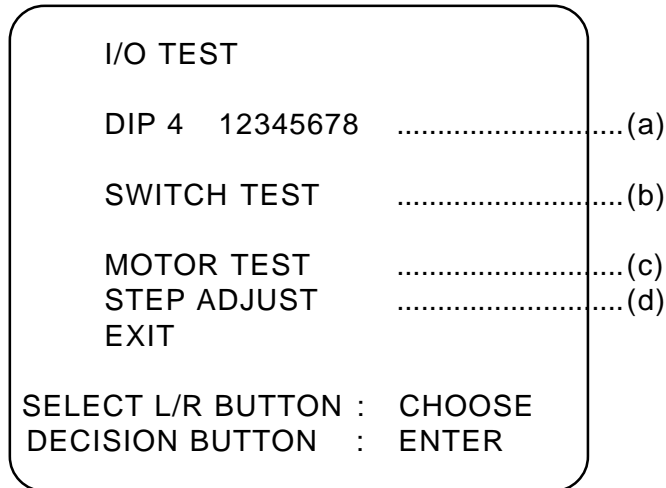

- (a) Shows condition of DIP SW 4 on the PCB. In normal operation all switches are OFF. (If a switch is ON, it will be displayed in red.)
- (b) For testing Switches and Control Pots. ([See 3-3-3-1](#))
- (c) For testing the Step-Lock Motor. ([See 3-3-3-2](#))
- (d) For initializing the Step Control Pots. ([See 3-3-3-3](#))

3-3-3-1 Switch Test

1. Select Switch Test from the 'I/O Test' menu. The following screen will appear on the monitor.

Note:- On entering Switch Test the Skis will be unlocked. Ensure that the Skis are returned to the locked condition at the end of the test by entering Motor Test (See 3-3-3-2)

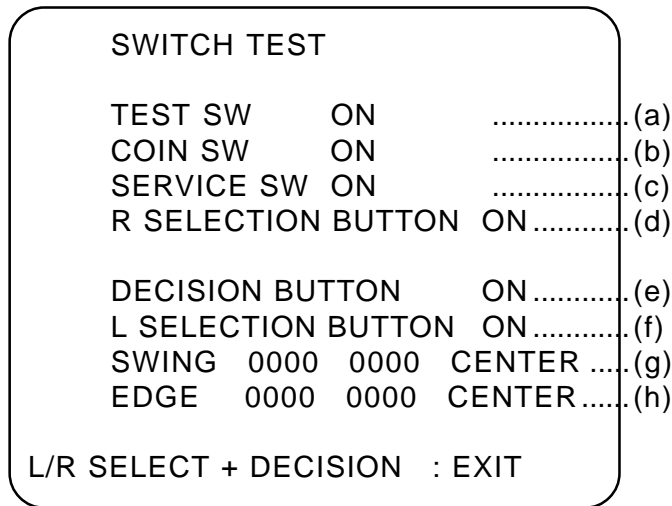

2. The word 'ON' will appear next to items (a) to (f) each time the respective switch is operated.
 When the skis are pushed left, 'SWING-CENTRE' will change to 'LEFT' and 'OK' will appear just before it reaches the extreme left,. When the skis are pushed right, 'CENTRE' will change to 'RIGHT' and 'OK' will appear just before it reaches the extreme right. '0000' will increase when the skis are moved to the right and decrease when they are moved to the left. When the skis are tilted, 'EDGE-CENTRE' will change to 'LEFT or RIGHT' and 'OK' will appear just before they are fully tilted. '0000' will change as the skis are tilted.

Note: "EDGE" 'OK' will only appear if you stand and apply weight to the edges of the ski steps. There is no problem if 'OK' is not displayed when standing on the steps in the same way as normal play.

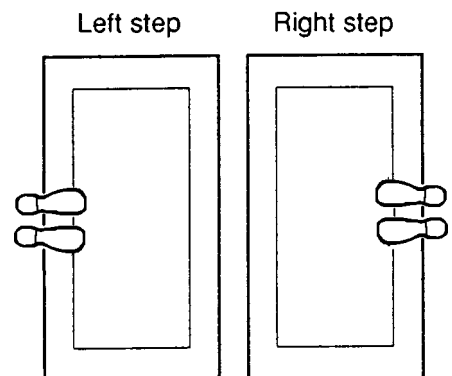

3. If 'OK' is not displayed when the edge is tilted left or right, re-initialize as described in section 3-4 "Initialization".
4. Operate both of the 'Select L/R' buttons and 'Decision' button together to exit and return to the 'I/O Test' menu screen.

3-3-3-2 Motor Test

1. Select Motor Test from the 'I/O Test' menu. The following screen will appear on the monitor.

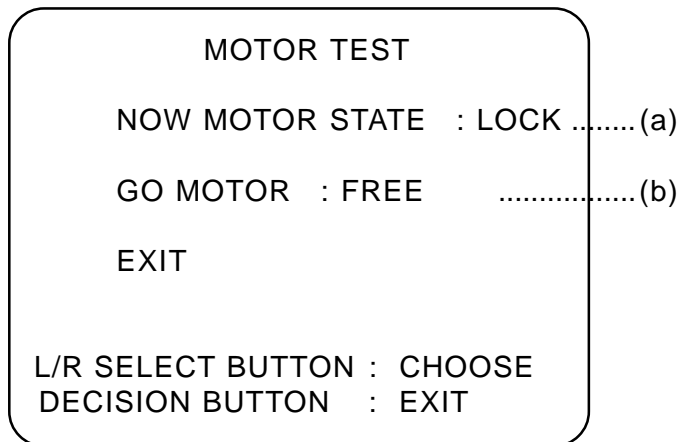

- (a) Displays the current condition of the Skis.
Display will show 'LOCK - FREEING - FREE - LOCKING' as the Skis are tested.
- (b) Allows the Skis to be locked and unlocked.
Display will show 'FREE - NOW MOVING - LOCK' as the Skis are being tested.

Note:- Ensure Skis are in the locked condition before returning to normal game mode.

3-3-3-3 Step Adjust

1. Select Step Adjust from the 'I/O Test' menu.

On entering 'STEP ADJUST' test, Step Adjust on the 'I/O' Menu Screen will blink and 'INITIALIZE COMPLETED' will appear and be blinking.

Ski Step initialization is now completed.

2. Select EXIT to return to the Main Menu Screen.

3-3-5 Monitor Test

1. Select item (5) "Monitor Test" on the menu screen to set up and adjust the monitor.
2. On entering monitor test, the screen will display one of the following test patterns.

```

GRADATION PATTERN
CROSSHATCH          GREEN
CROSSHATCH          WHITE
WHITE WINDOW        (H)
WHITE WINDOW        (M)
WHITE WINDOW        (L)
INTERLACE PATTERN
VIEW ANGLE ADJUST  (CRT)
VIEW ANGLE ADJUST  (PROJECTOR)
FULL WHITE
    
```

3. Use 'Select L/R' buttons to change to the next pattern and 'Decision' button to return to the Main Menu.

3-3-6 ADS Data

1. Select item (6) "ADS Data" on the menu screen to view machine history details.
2. The following screen will appear on the monitor.

ADS							
RACE	T.T.						
	NOV	INT	EXP	NOV	INT	EXP	
PLAY	0000	0000	0000	0000	0000	0000 (a)
GOAL	0000	0000	0000	0000	0000	0000 (b)
EXT0	0000	0000	0000	----	----	---- (c)
EXT1	0000	0000	0000	----	----	---- (d)
EXT2	0000	0000	0000	----	----	---- (e)
GATE	----	----	----	0000	0000	0000 (f)
	NOV	INT	EXP				
RACE	000'00"00	000'00"00	000'00"00			 (g)
T.T.	000'00"00	000'00"00	000'00"00			 (h)
PLAY TIME	000' 00" 00					 (i)
PLAY NUMBER	0000					 (j)
			INITIALIZE			 (k)
			EXIT				
L/R SELECT			:	CHOOSE			
DECISION			:	ENTER			

Item	Description
(a) Play	Total number of games played at each difficulty level for each course.
(b) Goal	Total number of games completed at each difficulty level for each course.
(c) Ext0	Number of games finishing at 1st extended time gate at each difficulty level in race game.
(d) Ext1	Number of games finishing at 2nd extended time gate at each difficulty level in race game.
(e) Ext2	Number of games finishing at 3rd extended time gate at each difficulty level in race game.
(f) Gate	Total number of gates completed for each difficulty level in T.T. game.
(g) Race	Total time in Hrs, Mins, Secs each difficulty level has been played in race game.
(h) T.T.	Total time in Hrs, Mins, Secs each difficulty level has been played in T.T. game.
(i) Play Time	Total time in Hrs, Mins, Secs game has been played.
(j) Play Number	Total number of game plays.
(k) Initialize	Resets all ADS Data to zero.

3-3-7 Others

1. Select item (7) "Others" on the menu screen.
2. On entering 'Others' the following screen will appear on the monitor.

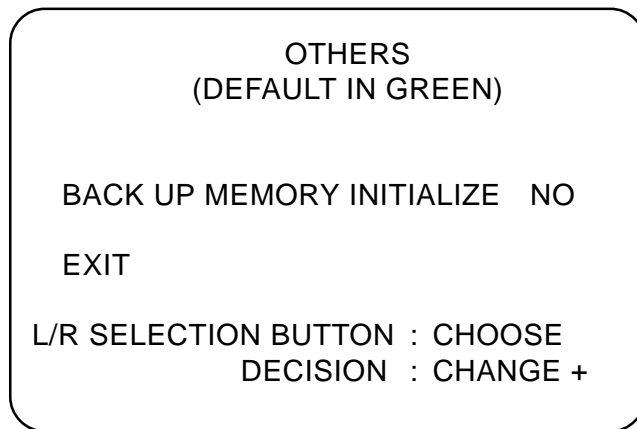

4 INITIALIZATION

Initialization must be performed before operation and after replacing the game PC board, Rom or Step Controls. If initialization is not performed, the game will not function correctly. During initialization, ensure that the step edges are level.

4-1 Adjustment Method (a)

1. When the power is turned ON the step-lock motor is automatically checked. The motor check first locks the steps, frees them, then locks them again.

Note: Ensure that the test switch is OFF during motor check. Also ensure that the steps are not touched during the motor check, or the check will not be performed correctly.

2. If the first lock is not completed within fifteen seconds from power up, an error display screen appears. If this happens, refer to [section 4-2](#) "Adjustment Method (b)", and initialize the controls. If the error display screen is still showing after the controls have been initialized, refer to [section 4-3](#), "Handling Motor Errors".

MOTOR ERROR 1
PLEASE STEP ADJUST

After the motor check is successful the attract screen is displayed.

3. To initialize the controls, Switch the test switch ON while pressing the service button. The screen displays the "SWITCH TEST" screen with INITIALIZE COMPLETED flashing, Initialization is completed.
4. Turn the test switch OFF to return to normal game mode.

```
SWITCH TEST

TEST SW      ON
COIN SW      ON
SERVICE SW  ON
R SELECTION BUTTON On
DECISION BUTTON ON
L SELECTION BUTTON ON
SWING 0000 0000 CENTER
EDGE 0000 0000 CENTER

INITIALIZE COMPLETED
L/R SELECT + DECISION : EXIT
```

4-2 Adjustment Method (b)

1. Slide the test switch ON.
2. Turn the power OFF and then back ON again.
3. Select "I/O TEST" and press the decision button (View Change).
4. Select "STEP ADJUST" and press the decision button. The controls are now initialized.
5. After initialization is completed, turn the test switch OFF.
The motor check begins. If the motor still does not operate correctly, there is a problem with the motor or switches, and an error will be displayed on the screen. Refer to section 4-3, below, "Handling Motor Errors", for fault finding.

4-3 Handling Motor Errors

If a problem has occurred with the step-lock motor, an error message and method of rectifying will be displayed on the screen.

1. Errors at Start-up
 - a. When the power is turned ON the step-lock motor is automatically checked. The motor check first locks the steps, frees them, then locks them again.

Note: Ensure that the test switch is OFF during motor check. Also ensure that the steps are not touched during the motor check, or the check will not be performed correctly.

- b. If the first lock is not completed within fifteen seconds from power up, the following error display screen appears.
If this happens, refer to [section 4-1](#) "Adjustment Method (a)", and initialize the controls.

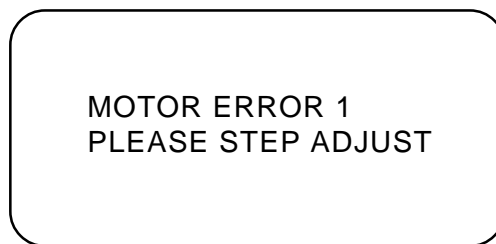

- c. If an error other than the one shown above is displayed, it is possible that a fuse has blown, there is a problem with the step-motor mechanism or the steps are not moving freely.
 - d. If the first lock is completed within fifteen seconds, but the steps cannot be released, Motor Error 2 screen is displayed until the fault is rectified.

- e. If after the steps have been freed, they do not re-lock, as an emergency measure, Motor Error 3 screen is displayed. This allows the step-lock mechanism to be overridden and the game to be operated with the steps permanently in the free position.

WARNING: It can be dangerous to operate the machine with the steps permanently free, so the fault *MUST* be repaired as soon as possible.

If the game is to be operated with the steps in the free condition, press the decision button. If either the Left or Right Select button is pressed the game will cease to function until the fault has been rectified.

MOTOR ERROR 2
OPERATION STOP!!

MOTOR ERROR 3
DO YOU WANT TO OPERATE
YES>PUSH DECISION BUTTON
NO>PUSH L/R SELECT BUTTON

2. An Error Occurs During Play.

- a. If the motor stops function during game play, the following error screen will be displayed.
- b. Turn the power OFF and then back ON.
The motor will be checked automatically.
- c. If there is still a problem, follow the instructions detailed in the Operators Manual section 6-4-3, "Errors At Start-up".

WARNING!
STEP LOCK DEVICE IS OUT
OF ORDER
CALL THE ATTENDANT
IMMEDIATELY.