

## **DEADHEAT 42"**

# **Operation Manual**

The actual product may differ slightly from the illustrations in this manual.

**⚠ WARNING**

- To ensure safe operation of the machine, be sure to read this Operation Manual before use.
- Keep this Operation Manual in a safe place for quick access whenever needed.

# Introduction

Thank you very much for purchasing DEADHEAT (referred to as the “machine” in this manual).

---

## **This Operation Manual describes:**

- How to safely install, operate, move, transport, maintain and dispose of the machine.
- How to make full use of the machine’s functions and operate it correctly.
- How to ensure the safety of players and bystanders.

## **Contact for machine and machine repair inquiries**

- For inquiries regarding the machine or machine repairs, contact your distributor.

The software included in the machine is protected by copyright law. The software may not be copied, distributed publicly or used for purposes other than the operation of this machine. Violators of copyright laws may be subject to criminal penalties. Do not use the storage media containing the software in any other game machine. Doing so may cause that machine to malfunction.

However, note that GNU General Public License (GPL) or GNU Lesser General Public License (LGPL) applies to some of the software in this machine. You may access, modify and redistribute the source code of this software. However, please understand that this applies to only a part of this product, and it does not mean that you are allowed to access, modify or redistribute all of the source code in the product.

For details on GPL and LGPL, see the following web pages.

<http://www.gnu.org/licenses/gpl-2.0.html>

<http://www.gnu.org/licenses/lgpl-2.1.html>

If you want to access the GPL/LGPL-applicable source code that is used in this machine, contact your distributor.

The rights to the fonts used in the game belong to:

© RYOBI LIMITED

Bitstream Inc. All rights reserved.

Dodge is a trademark of Chrysler Group LLC.

Dodge Viper and its trade dress are used under license by NAMCO BANDAI Games Inc.

© Chrysler Group LLC 2010.

Ford Oval and nameplates are registered trademarks owned and licensed by Ford Motor Company.

CHEVROLET, CORVETTE C6 ZR-1, all related Emblems, and vehicle body designs are General Motors Trademarks used under license to NAMCO BANDAI Games Inc.

Mazda, RX-7, emblems and body designs are used under approval from Mazda Motor Corporation.

Mitsubishi, Lancer Evolution X, names, emblems and body designs are trademarks and/or intellectual property rights of MITSUBISHI MOTORS CORPORATION.

NISSAN, 370Z, SKYLINE GT-R V-SPEC II, logo, marks and designs of the NISSAN products are trademarks and/or intellectual property rights of NISSAN MOTOR CO., LTD. and used under license to NAMCO BANDAI Games Inc.

NOS and Nitrous Oxide Systems are registered trademarks of Holley Performance Products.

# 1. Safety Precautions – Be sure to read to ensure safe operation –

---

## Instructions to the Owner

If you delegate the work for installing, operating, moving, transporting, maintaining or disposing the machine to other people, ensure that these people read the relevant sections of this operation manual carefully before starting work, and observe the corresponding precautions.

### 1-1 Levels of Risk

The safety and property damage precautions on the machine labels and in this Operation Manual are classified according to their risk level, as follows.

 **WARNING** : Failure to avoid these risks may result in serious injury or death

 **CAUTION** : Failure to avoid these risks may result in light injury or damage to other property

Notes about functionality that are not linked to safety are indicated with the following symbol.

 **NOTICE** : Information about product functions or protection

### 1-2 Definition of “Technician”

This Operation Manual is designed for arcade personnel. However, the sections marked “Must be performed by a technician” in the Table of Contents are written for technicians. These must be performed by technicians only.

**Technician:** A person involved in the design, manufacture, inspection, maintenance or service at an amusement device manufacturer, or a person involved routinely in the maintenance or management (such as repair) of amusement devices and has specialist knowledge of electricity, electronics or mechanical engineering equivalent to or higher than a technical high school graduate.

## 1-3 Critical Safety Precautions

### WARNING

- Should an abnormality occur, turn off the power switch immediately to stop operations. Then, be sure to disconnect the power cord plug from the outlet. Operating the machine while the abnormality persists may result in a fire or accident.
- Sections of the LCD monitor remain at a high temperature and high voltage even after the power switch is turned off.  
To avoid electric shock or burns, be careful not to accidentally touch these sections.
- Dust accumulating on the power cord plug may cause a fire. Inspect the plug regularly and remove any dust.
- Fully insert the power cord plug into the outlet. Poor contact may generate heat and cause a fire or burns.
- Damage to the power cord may result in a fire, electric shock or electrical leakage. Be sure to observe the following.
  - Keep the power cord away from heaters.
  - Do not twist the power cord.
  - Do not forcibly bend the power cord.
  - Do not alter the power cord.
  - Do not bundle the power cord.
  - Do not pull the power cord. (Always unplug by holding the plug and not the power cord.)
  - Do not place objects on the power cord.
  - Do not allow the power cord to be caught between the machine and other devices or the wall.
  - Do not do anything else that might damage the power cord.
- Do not expose the power cord and power cord plug to water. It may result in electric shock or electrical leakage.
- Do not touch the power cord plug with wet hands. It may result in electric shock.
- The power capacity of the machine is AC 570W. To prevent fire and electric shock, use interior wiring that conforms to these power supply specifications.
- Keep a power supply voltage range of AC  $\pm 10\%$ . Using a voltage outside this range may result in a fire or electric shock. However, to ensure that the machine operates in the optimum condition, keep the voltage at nominal line voltage as much as possible.
- To ensure safe use of the machine, be sure to perform the pre-operation inspection (see “7-2 Pre-operation Inspection” on page 20) and service (see “8B. Service” on page 59) described in this Operation Manual. Omitting these inspections or service may result in an accident.
- Use the consumables and service parts (including screws) that are specified by our company. To order parts, contact your distributor.
- Do not modify the machine without permission. Do not perform any operations that are not described in this Operation Manual. Modifying the machine may create unforeseen hazards.
- If you decide to transfer the ownership of this machine, be sure to provide this Operation Manual with the machine.

## 1-4 Machine Warning Labels

### WARNING

- The warning labels contain important information for ensuring safety. Be sure to observe the following.
  - To ensure that the warning labels attached to the machine are always clearly visible, install the machine in an appropriate location with ample illumination, and keep the labels clean at all times. Make sure that the labels are not hidden by other game machines or objects.
  - Do not remove or alter the warning labels.
  - If a warning label becomes excessively dirty or damaged, replace it with a new one. To order warning labels, contact your distributor.

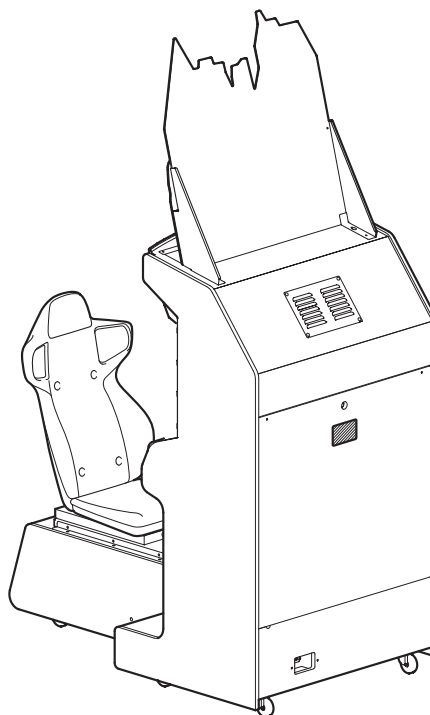

# Table of Contents

---

## Introduction

1. Safety Precautions – Be sure to read to ensure safe operation – .....	1
1-1 Levels of Risk.....	1
1-2 Definition of “Technician”.....	1
1-3 Critical Safety Precautions .....	2
1-4 Machine Warning Labels.....	3
Table of Contents.....	4
2. Specifications .....	8
3. Package Contents .....	10
4. Overall Structure (Part Names) .....	12
5. Delivery and Installation Conditions .....	13
5-1 Installation Conditions .....	13
5-1-1 Installation Locations to Avoid .....	13
5-1-2 Play Zone for the Installed Machine .....	14
5-2 Required Dimensions for the Delivery Route (Such as Doors and Corridors) .....	15
6. Moving and Transporting .....	16
6-1 Moving (On the Same Floor).....	16
6-2 Transporting .....	17
6-2-1 Transporting Manually (Such as Carrying on Stairs).....	17
6-2-2 Transporting on a Vehicle.....	18
7. Operation .....	19
7-1 Safety Precautions for Playing .....	19
7-2 Pre-operation Inspection .....	20
7-2-1 Safety Inspection (Before Power On).....	20
7-2-2 Function Inspection (After Power On) .....	21
7-3 Playing the Game.....	22
7-4 Explanation of the Power Switch and Adjustment Switches .....	24
7-4-1 Power Switch Position and Turning the Power Switch On .....	24
7-4-2 Adjustment Switches .....	25

7-5 Test Mode .....	26
7-5-1 Description of the MENU Screen .....	26
7-5-2 Game Cost and Free Play Settings (COIN OPTIONS) .....	27
7-5-3 Communication Settings (GAME OPTIONS) .....	28
7-5-4 Testing the Switches and Lamps (I/O TEST).....	30
(a) CAMERA SETTING.....	31
(b) I/F INITIALIZE (STEERING & GAS).....	33
(c) SWITCH TEST .....	35
(d) LAMP TEST.....	37
(e) I/O PCB CHECK.....	38
7-5-5 Monitor Test (MONITOR TEST) .....	39
7-5-6 Sound Test (SOUND TEST) .....	40
7-5-7 Data Clear (DATA CLEAR) .....	41
7-5-8 Other (OTHERS) .....	42
(a) CLOCK SETTING .....	43
(b) EMERGENCY MODE SETTING .....	44
<b>8. Technician's Manual — Must be performed by a technician — .....</b>	<b>46</b>
<b>8A. Installation and Assembly.....</b>	<b>46</b>
8A-1. Assembly .....	46
8A-1-1 Installing the Signboard Assembly .....	46
8A-1-2 Connecting the Front Assembly to the Seat Assembly and Level Adjuster Adjustment .....	48
8A-1-3 Connecting Two Machines for Communication.....	50
(1) Connection Diagram.....	50
(2) Connection Method .....	51
8A-1-4 Connecting Three or Four Machines for Communication .....	53
(1) Connection Diagram.....	53
(2) Connection Method .....	54
8A-1-5 Connecting the Power Cord and Ground.....	55
8A-1-6 Power Switch Position and Turning the Power Switch On.....	56
8A-1-7 Communication Settings .....	57
<b>8B. Service .....</b>	<b>59</b>
8B-1 Inspections and Service.....	59
8B-1-1 Inspection Items.....	59
(1) Level Adjuster Inspection .....	59
(2) Power Cord Plug Inspection .....	59
(3) Screw Looseness Inspection.....	59
8B-2 Troubleshooting .....	60
8B-2-1 General .....	60
8B-2-2 Front Assembly .....	61
8B-2-3 Steering Assembly .....	61
8B-2-4 Shift Assembly .....	62
8B-2-5 Pedal Assembly .....	62
8B-2-6 Keypad .....	62

---

8B-3 Error Displays (For Technicians).....	63
8B-3-1 Coin Errors.....	63
8B-3-2 Steering Assembly Errors .....	63
8B-3-3 I/O Board Errors.....	64
8B-3-4 Camera Errors .....	64
8B-3-5 Dongle Errors.....	64
8B-4 Removing and Installing Assemblies and Parts.....	65
8B-4-1 Front Assembly .....	65
(1) Replacing the Fluorescent Lamp.....	65
(2) Removing and Installing the Control Cover.....	66
(3) Replacing the View Selector, NITROUS Switch and Lamps .....	67
(4) Replacing the LCD Monitor .....	68
(5) Replacing the Steering Assembly.....	72
(6) Replacing the Shift Assembly.....	74
(7) Replacing the Keypad .....	75
(8) Replacing the LEDs (3.5").....	76
(9) Replacing the Camera.....	77
(10) Replacing the LEDs.....	78
8B-4-2 Front Assembly Rear Side .....	79
(1) Replacing the SYS ES1 (B) Assembly .....	79
(2) Replacing the Steering PC Board .....	81
(3) Replacing the NA-JV PC Board .....	82
(4) Replacing the Amp PC Board.....	83
(5) Replacing the Power Supply (12 V) .....	84
(6) Replacing the Fuse .....	85
8B-4-3 Pedal Assembly .....	86
(1) Removing and Installing the Pedal Assembly .....	86
8B-4-4 Seat Assembly .....	87
(1) Replacing the Slide Unit .....	87
(2) Replacing the LED (14.2").....	88
9. Disposal.....	89
10. Parts List.....	90
10-1 Front Assembly 1/2 .....	90
10-1 Front Assembly 2/2 .....	92
10-2 Cord Box Assembly.....	94
10-3 Signboard Assembly .....	95
10-4 Seat Assembly .....	96
10-5 Pedal Assembly.....	98
10-6 Steering Assembly .....	99
10-7 Shifter Assembly .....	100
11. Wiring Diagram .....	101
11-1. Overall Wiring Diagram .....	101
11-2. Overall Wiring Diagram .....	102



---

# MEMO

## 2. Specifications

---

(1) Rated power supply AC	120 ± 10 V (50/60 Hz) / 230V ± 10V (50/60 Hz.)
(2) Rated power consumption	570 W
(3) Maximum consumption current	4.75 A / 2.4A
(4) Monitor	LCD monitor (42-inch)
(5) Dimensions when installed	Width (W) 40.476" × depth (D) 63" × height (H) 105.5" 103 cm. 160cm. 268cm.

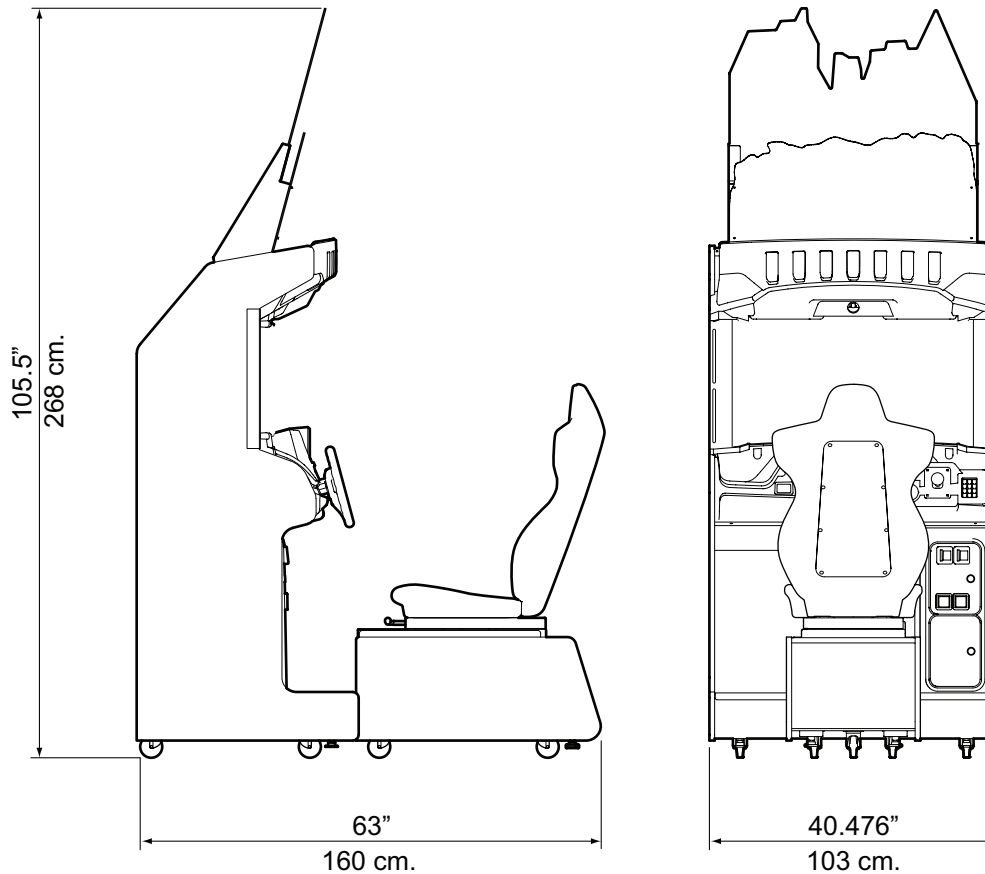

Front assembly      Width (W) 40.476" × depth (D) 30.3" × height (H) 74.718"  
 103 cm                      77 cm                      190 cm

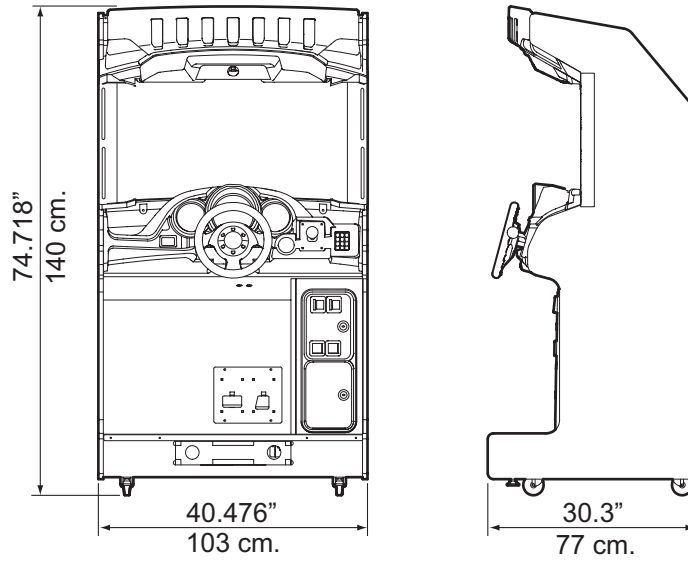

Seat assembly      Width (W) 22" × depth (D) 33.9" × height (H) 51.2"  
 56 cm.                      86 cm.                      130 cm.

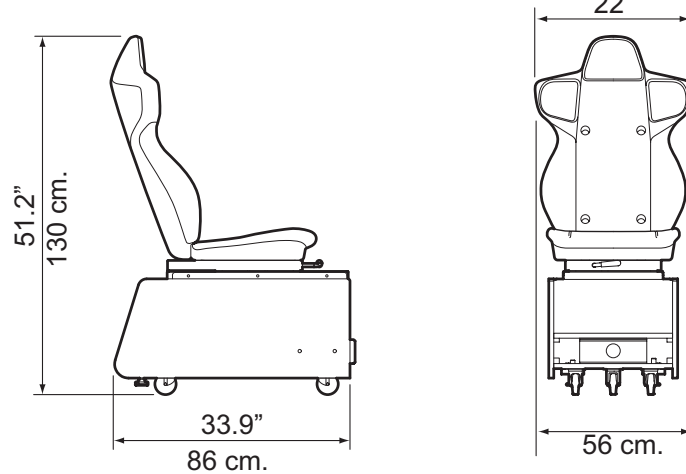

Signboard assembly      Width (W) 33.9" × depth (D) 15.4" × height (H) 35"  
 86 cm.                      39 cm.                      89 cm.

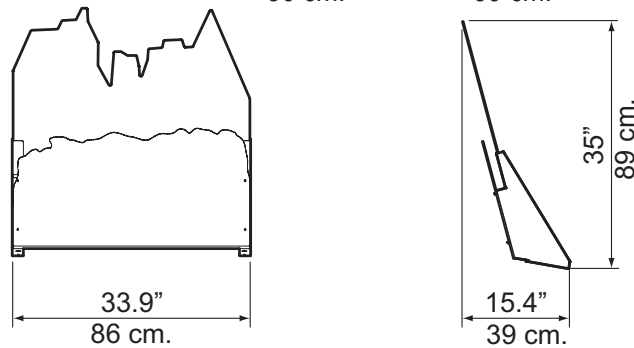

(6) Weight







①When installed	Approx. 463 lb 211 Kg.
②When disassembled	
Front assembly	Approx. 352.7 lb 160.5 Kg.
Seat assembly	Approx. 99.2 lb 45.5 Kg.
Signboard assembly	Approx. 11 lb 5 Kg.

# 3. Package Contents

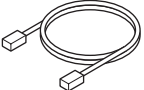
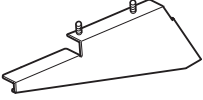
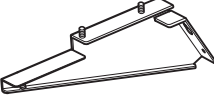
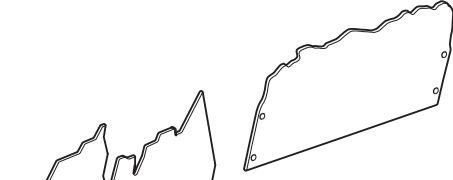
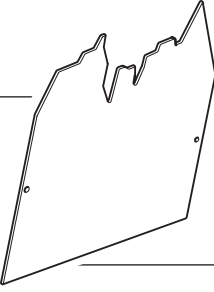

- Make sure that all the items below are contained in the product package.
- If any items are missing, contact your distributor.

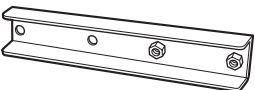
## ● Supplied Item List

No.	Name	Specification	Qty.
1	Operation Manual	(this manual) 	1
2	Service key		2
3	Cashbox key		2
4	Communication cable	196.9" 	1
5	Signboard stay (R)		1
6	Signboard stay (L)		1
7	Title panel F		1
8	Title panel B		1
9	Hexagon cap nut	M5 	6
10	Flat washer (black)	ø6 x 20 x t1.0 	4
11	Connection bracket		2
12	Button head bolt (black)	M8 x 30 	8
13	Flat washer (black)	ø9 x 30 x 2.3 	4

---

**MEMO**

# 4. Overall Structure (Part Names)

Front

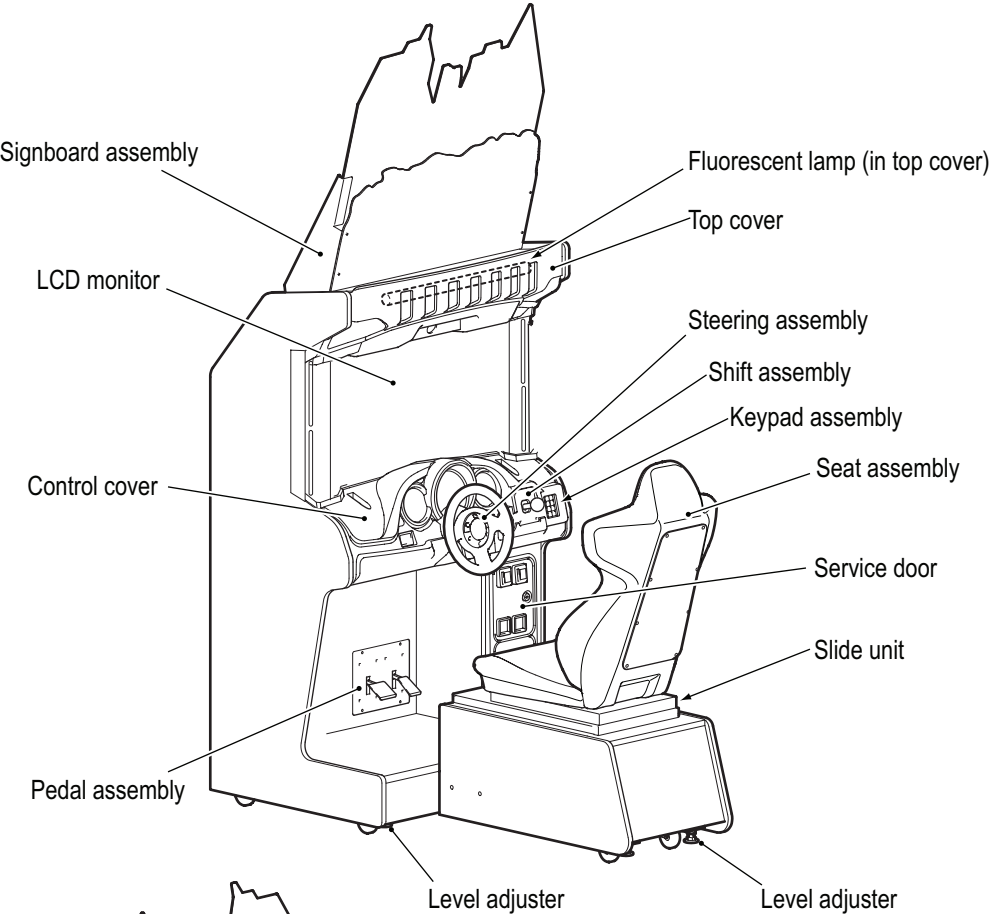

Rear

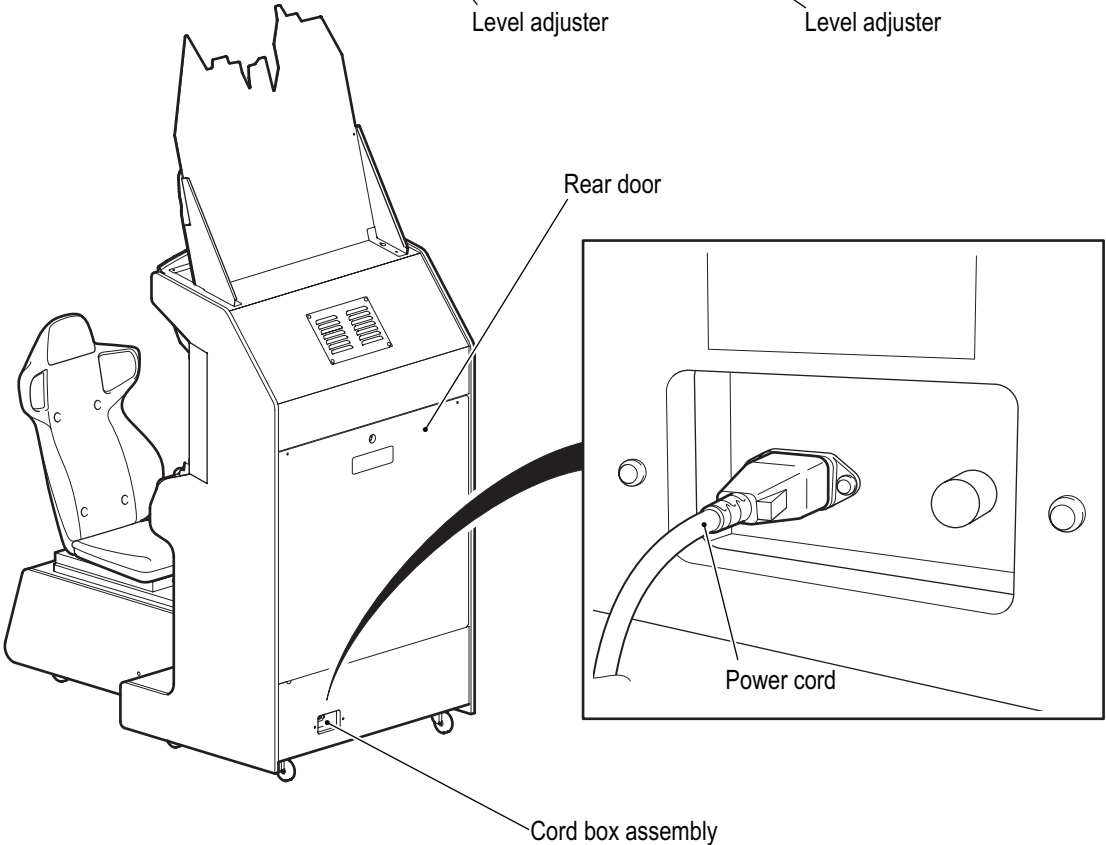

# 5. Delivery and Installation Conditions

---

## WARNING

- Install the machine according to the instructions in this Operation Manual. If you do not follow these instructions, it may result in a fire, electric shock, injury or malfunction.
- Fully insert the power cord plug into the outlet. Poor contact may generate heat and cause a fire or burns.
- Be sure to install the ground wire. Failure to install the ground wire may result in electric shock in the event of electrical leakage. (See “8A-1-5 Connecting the Power Cord and Ground” on page 55.)
- Install the machine securely by using the level adjusters. Unstable machine installation may result in an accident or injury. (See “8A-1-2 Connecting the Front Assembly to the Seat Assembly and Level Adjuster Adjustment” on page 48.)

## 5-1 Installation Conditions

### 5-1-1 Installation Locations to Avoid

## WARNING

- The machine is designed for indoor use. Never install the machine outside or in the following locations.
  - A location exposed to direct sunlight
  - A location exposed to rain or water leaks
  - A damp location
  - A dusty location
  - A location close to heaters
  - A hot location
  - An extremely cold location
  - A location exposed to condensation caused by temperature differences
  - A location that obstructs an emergency exit or fire extinguishing equipment
  - An unstable location or a location exposed to vibration

### 5-1-2 Play Zone for the Installed Machine

**⚠ CAUTION**

- Create a play zone around the machine so that the player does not make contact with bystanders or passersby.

**NOTICE**

- Keep 19.7" or more between the rear of the machine and the wall or other machines to enable the rear door to be removed for service.
- The room height must be 102.4" or more from the floor to the ceiling.

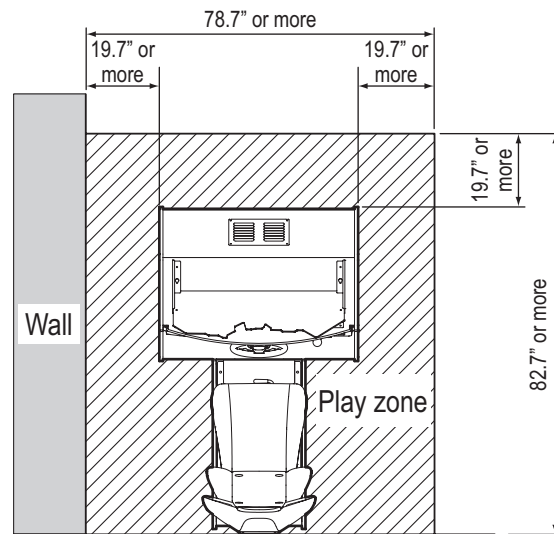

- When installing two or more machines, keep a gap of 3.9" or more between the machines.  
Example: Installing two machines

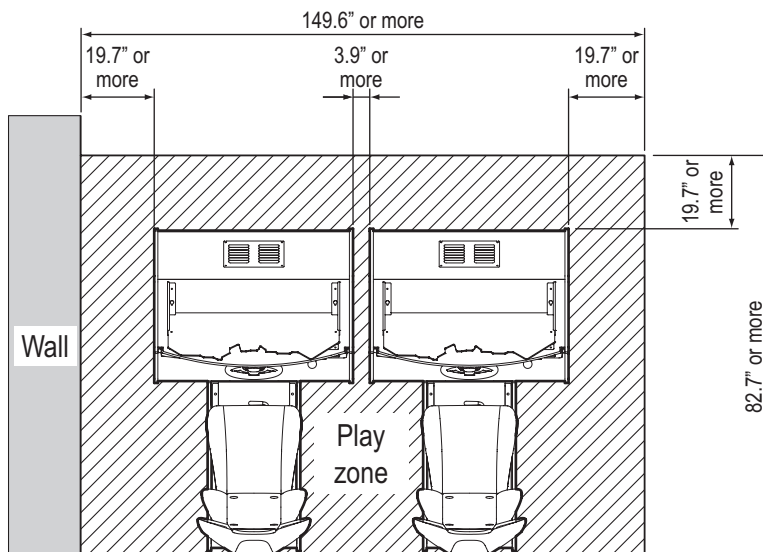



## 5-2 Required Dimensions for the Delivery Route (Such as Doors and Corridors)

The machine is disassembled at the time of shipment. The sizes of the main parts are as follows.

- Front assembly Width (W) 40.476" (103 cm.) x depth (D) 30.3" (77 cm.) x height (H) 74.718" (190 cm.) Weight 352.7 lb 160.5 Kg.
- Seat assembly Width (W) 22" (56 cm.) x depth (D) 33.9" (86 cm.) x height (H) 51.2" (130 cm.) Weight 99.2 lb

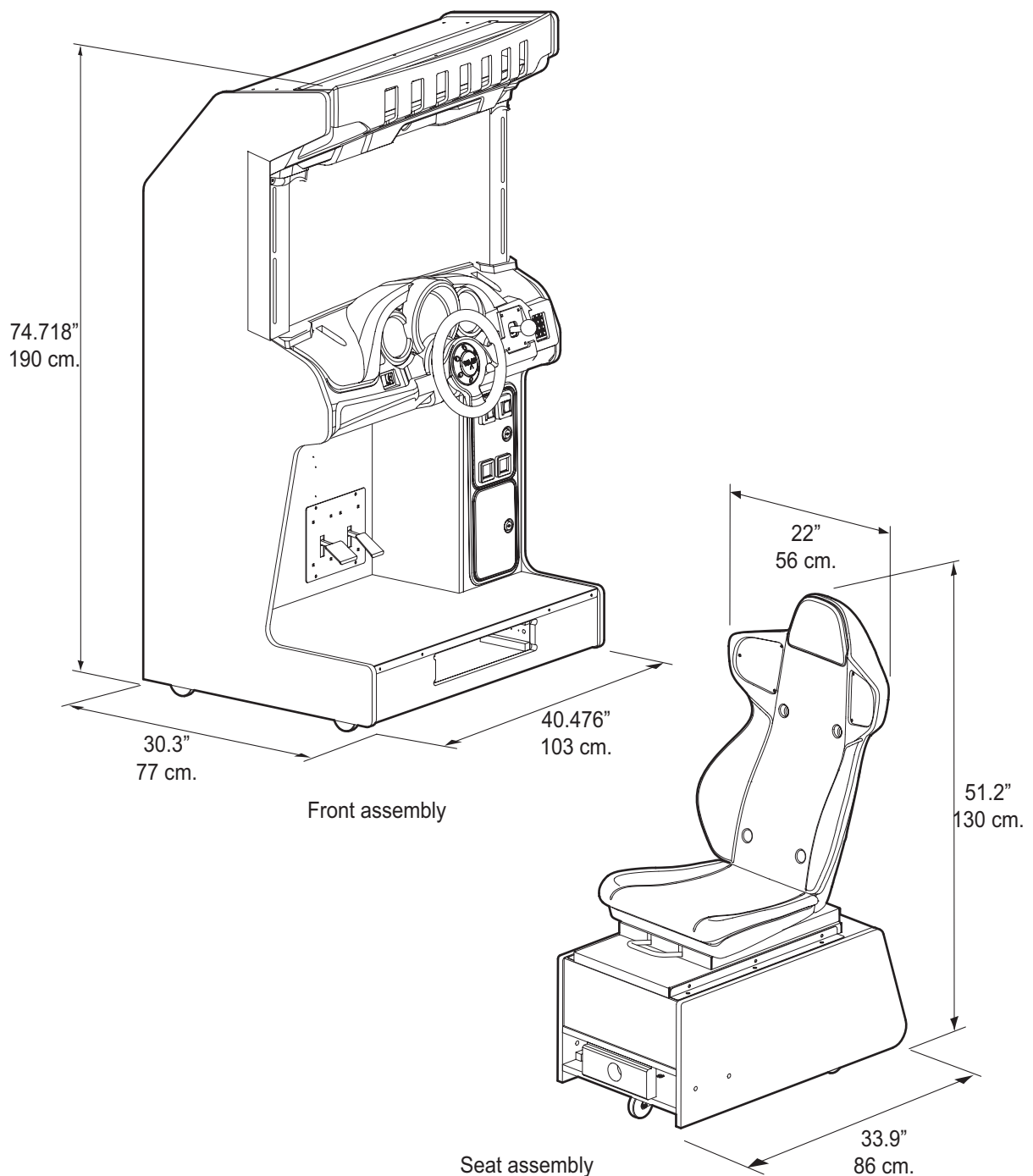

# 6. Moving and Transporting

---

## WARNING

- Do not leave the machine on a slope. It may fall over or cause an accident.

### 6-1 Moving (On the Same Floor)

## WARNING

- When moving the machine on the same floor, first separate the front assembly from the seat assembly.  
Failure to do this may result in floor damage, or the machine may block your view and result in a collision or other accident.  
(See “8A-1 Assembly” on page 46.)
- (See **6** in “8A-1-2 Connecting the Front Assembly to the Seat Assembly and Level Adjuster Adjustment” on page 49.)

## NOTICE

- Move the machine carefully to avoid damaging it.
- The plastic areas are weak. Do not exert strong amounts of force on them.
- Even when moving the machine only a short distance, be sure to raise the level adjusters to their highest level.  
(See “8A-1-2 Connecting the Front Assembly to the Seat Assembly and Level Adjuster Adjustment” on page 48.)
- Be sure to turn the power off before performing these operations.
- Handle the power cord carefully. (See “8A-1-5 Connecting the Power Cord and Ground” on page 55.)

## 6-2 Transporting

### 6-2-1 Transporting Manually (Such as Carrying on Stairs)

#### WARNING

- Before transporting the machine manually, be sure to separate the front assembly, seat assembly and signboard assembly, and raise all the level adjusters to their highest level. (See “8A-1 Assembly” on page 46.) Transporting the machine (such as carrying it on stairs) while it is fully assembled may result in an accident.
- When transporting the machine manually, be sure to use the following number of people. Overburdening yourself may result in an accident or injury.
  - Front assembly (approx. 352.7 lb / 160 Kg.): 7 people or more
  - Seat assembly (approx. 99.2 lb / 46 Kg.): 2 people or more

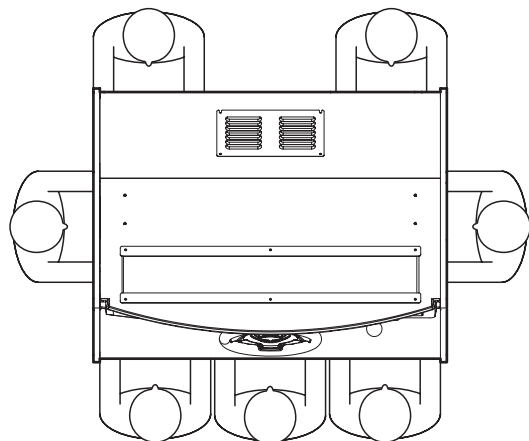

Front assembly

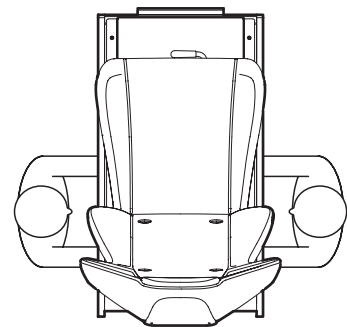

Seat assembly



- Do not subject the machine to impact while lowering it.

## 6-2-2 Transporting on a Vehicle

 **WARNING**

- Before transporting the machine on a vehicle, be sure to separate the front assembly, seat assembly and signboard assembly, and raise all the level adjusters to their highest level.  
Transporting the machine while it is fully assembled may result in an accident.
- When using a fork lift to transport the machine, observe the following. Failure to observe the following instruction may result in an accident, such as the machine falling over.
  - Make sure that the machine is balanced properly during transportation.
- When transporting the machine manually, be sure to use the following number of people. Overburdening yourself may result in an accident or injury.
  - Front assembly (approx. 352.7 lb / 160 Kg.): 7 people or more
  - Seat assembly (approx. 99.2 lb / 46 Kg.): 2 people or more

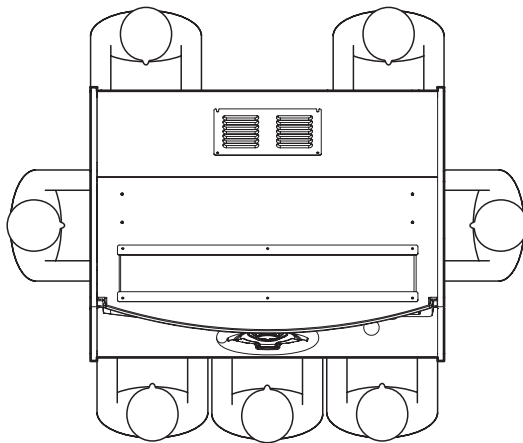

Front assembly

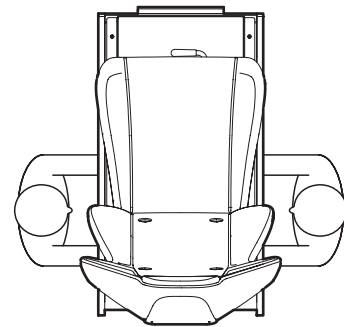

Seat assembly



- Do not subject the machine to impact while lowering it.

# 7. Operation

---

## WARNING

- Should an abnormality occur, turn off the power switch immediately to stop operations. Then, be sure to disconnect the power cord plug from the outlet. Operating the machine while the abnormality persists may result in a fire or accident.
- Dust accumulating on the power cord plug may cause a fire. Inspect the plug regularly and remove any dust.
- Fully insert the power cord plug into the outlet. Poor contact may generate heat and cause a fire or burns.
- Before operating the machine, be sure to check that installation has been performed according to the instructions and specified procedures (5. Delivery and Installation Conditions, page 13) in this Operation Manual. Failure to install the machine correctly may result in a fire, electric shock, injury or malfunction.
- The warning labels contain important information for ensuring safety. Be sure to observe the following.
  - To ensure that the warning labels attached to the machine are always clearly visible, install the machine in an appropriate location with ample illumination, and keep the labels clean at all times. Make sure that the labels are not hidden by other game machines or objects.
  - Do not remove or alter the warning labels.
  - If a warning label becomes excessively dirty or damaged, replace it with a new one.To order warning labels, contact your distributor.
- To ensure safe use of the machine, be sure to perform the pre-operation inspection (see “7-2 Pre-operation Inspection” on page 20) and service (see “8B. Service” on page 59) described in this Operation Manual. Omitting these inspections or service may result in an accident.

## 7-1 Safety Precautions for Playing

### CAUTION

- If players start feeling ill because of the game images or light stimulation, they must stop playing immediately.
- In rare cases, stimulation by lights or video images may cause the player to have a seizure or lose consciousness. If this happens, advise the player to consult a doctor as soon as possible. When pre-school children play, instruct their parents or guardians to observe them.

## 7-2 Pre-operation Inspection

Check the items below before starting machine operations.

If there is an abnormality, resolve it by referring to “8B-2 Troubleshooting” on page 60.

### 7-2-1 Safety Inspection (Before Power On)

#### WARNING

- **Before operating the machine, perform “7-2-1 Safety Inspection (Before Power On)” on page 20.  
This is required to prevent accidents or injuries.**
- **Before operating the machine, check “5-1-1 Installation Locations to Avoid” on page 13. This is required to prevent accidents or injuries.**
- **Operating the machine while parts are broken, damaged or deteriorated, or while the installation is defective, may result in an injury to the player or a bystander. If you discover an abnormality, replace the affected part immediately. To order parts, contact your distributor.**

- (1) Are all warning labels in place? (See “1-4 Machine Warning Labels” on page 3.)
- (2) Are all warning labels legible? (See “1-4 Machine Warning Labels” on page 3.)
- (3) Are all level adjusters adjusted properly? (See “8A-1-2 Connecting the Front Assembly to the Seat Assembly and Level Adjuster Adjustment” on page 48.)
- (4) Is the specified play zone provided? (See “5-1-2 Play Zone for the Installed Machine” on page 14.)
- (5) Are the power cable and communication cables laid out safely so they will not cause players or other customers to trip over them?
- (6) Is the power cord securely connected to the outlet and the cord box assembly on the bottom of the machine rear? (See “8A-1-5 Connecting the Power Cord and Ground” on page 55.)
- (7) Is the power cord plug free from dust? (See “8A-1-5 Connecting the Power Cord and Ground” on page 55.)
- (8) Are molded parts such as the seat assembly free from damage?

Inspect the following items after turning on the power switch. If you discover an abnormality, turn off the power switch immediately to stop operations. Then, disconnect the power cord plug from the outlet and contact your distributor.

- (9) Is any part of the power cord or plug abnormally hot?
- (10) Does touching the machine give a tingling electric shock?
- (11) Is there a burning smell, abnormal noise or vibration?
- (12) Is there any other abnormality, damage or malfunction?

---

## 7-2-2 Function Inspection (After Power On)

Check the following items in Test mode. (See “7-4-2 Adjustment Switches” on page 25.)

- (1) Check the lamps. (Do the fluorescent lamp and NITROUS switch light up?)  
(See “7-5-4 Testing the Switches and Lamps (I/O TEST)” on page 30.)
- (2) Check the NITROUS switch operation.  
(See “7-5-4 Testing the Switches and Lamps (I/O TEST)” on page 30.)
- (3) Check the steering operation.  
(See “7-5-4 Testing the Switches and Lamps (I/O TEST)” on page 30.)
- (4) Check the pedal operation.  
(See “7-5-4 Testing the Switches and Lamps (I/O TEST)” on page 30.)
- (5) Check the shift lever operation.  
(See “7-5-4 Testing the Switches and Lamps (I/O TEST)” on page 30.)
- (6) Check the keypad operation.  
(See “7-5-4 Testing the Switches and Lamps (I/O TEST)” on page 30.)
- (7) Check the displayed images. (Does the monitor operate properly?)  
(See “7-5-5 Monitor Test (MONITOR TEST)” on page 39.)
- (8) Check the audio. (Is sound produced by each speaker?)  
(See “7-5-6 Sound Test (SOUND TEST)” on page 40.)

---

## 7-3 Playing the Game

### CAUTION

- If you discover anyone behaving as follows, tell them to stop immediately. Such behavior may cause an accident.
  - Two people sitting on the machine at the same time.
  - A person other than the player touching the control parts (steering wheel or shift lever).
- If players start feeling ill because the game images or light stimulation, they must stop playing immediately.
- In rare cases, stimulation by lights or video images may cause the player to have a seizure or lose consciousness. If this happens, advise the player to consult a doctor as soon as possible. When pre-school children play, instruct their parents or guardians to observe them.

This machine is a racing game where players ride simulations of actual vehicles on public roads in depictions of actual cities. In the race mode, eight vehicles race against each other, including the player's own vehicle. Up to four players can race against each other using the arcade's internal communication. The camera on the machine can take pictures of the player's face. The faces of the players then appear during the race, adding to the fun of the game.

When a PIN (Personal Identification Number) is registered, information, such as the player's vehicle, customization status and record of races with friends, can be stored.

### Game Overview

#### ■ About the PIN

- When a PIN is registered on this machine, play information can be saved in the machine, and the player can continue from the end of the previous game. (The play information consists of the registered PIN, the player's driving data, the data for photographed pictures, the data for acquired parts, and the data for races with friends when the PIN was used.)
- The PIN registration screen is displayed after the race finishes during the first play. When a PIN is registered, three NITROUS credits are given to the player. These allow rapid acceleration of the vehicle. (Only one credit is given if a PIN is not registered.)
- To use the PIN and continue from the previous game, enter the registered PIN during the PIN entry time. The PIN entry time lasts from the selection of SELECT YOUR CAR to SELECT YOUR CITY after the game is started.
- During the PIN entry time, "Have you registered a PIN? If so, please enter it now." is displayed on the game screen.
- After entering the PIN, the "Profile" screen is displayed and play can be continued. (The profile screen displays the data for photographed pictures, the data for acquired parts, and the data for races with friends when the PIN was used.)



### ■ Starting the Game

- When the coins are inserted, the “SELECT YOUR CAR” screen is displayed. Select your car within the time limit.
- After a car is selected, the “SELECT YOUR COLOR” screen is displayed. Select a car body color within the time limit. The transmission type can also be selected in the “SELECT YOUR COLOR” screen. When deciding the body color, set the view selector to ON to select “MT,” and set it to OFF to select “AT.”
- After the body color is selected, the “SELECT YOUR CITY” screen is displayed. Select a city (course) within the time limit.
- After the city (course) is selected, the “LET’S TAKE YOUR PICTURE” screen is displayed. The camera assembly is used to take a picture of your face. Your face picture is displayed on the game screen.
- After your face picture is shot, a race starts consisting of eight vehicles, including your vehicle. Try to finish the race within the time limit. When the time reaches 0, your time is up.

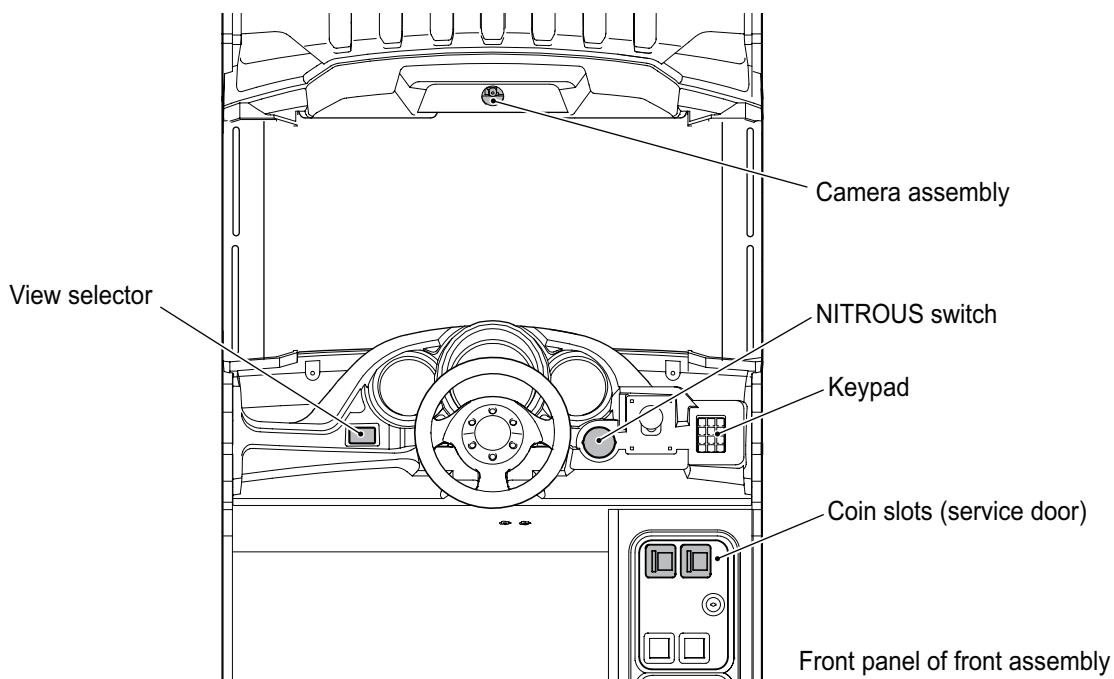

### ■ About Customization

- When a race is finished in a game using a PIN, customized parts can be acquired.
- In total, there are 36 types of customized parts.

BODY KIT .....	1 type	WHEELS.....	12 types
HOOD .....	4 types	GRAPHICS .....	16 types
REAR SPOILER .....	2 types	FIN .....	1 type

- The customized parts do not affect the racing performance of the vehicle.

## 7-4 Explanation of the Power Switch and Adjustment Switches

### 7-4-1 Power Switch Position and Turning the Power Switch On

- 1 Turn on the power switch of the machine.

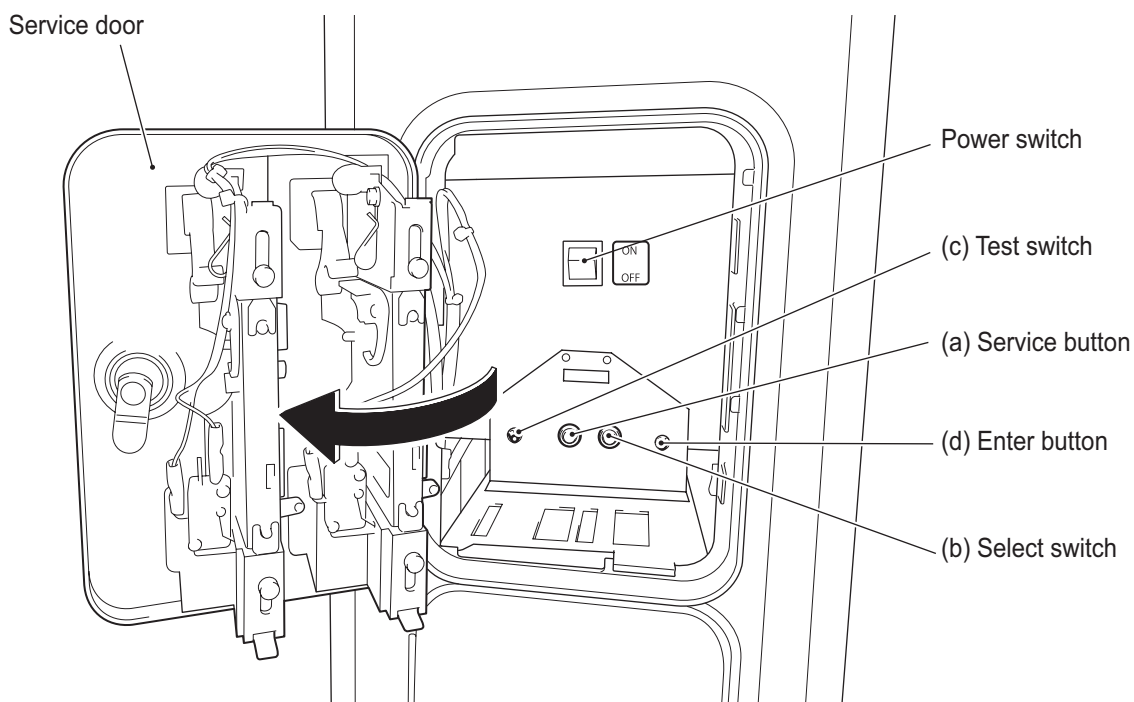

- Do not turn the power switch on and off repeatedly, because it may cause a machine malfunction.

## 7-4-2 Adjustment Switches

Open the service door for access to the adjustment switches.

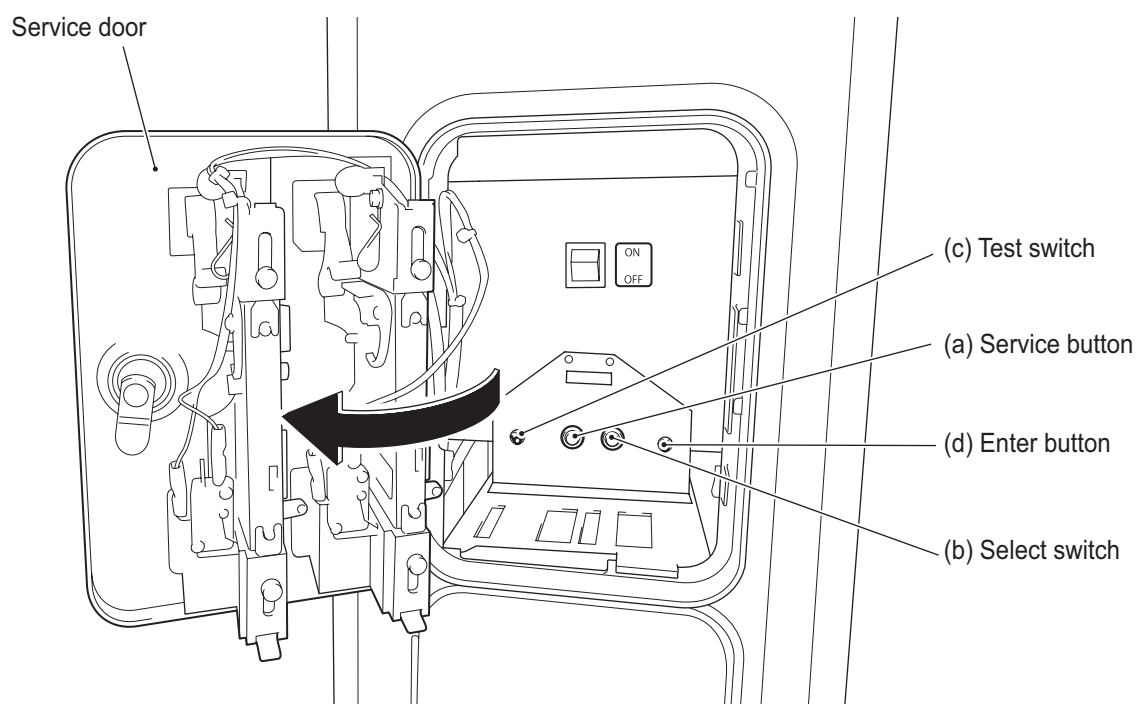

**(a) Service button (red)**

Press this button to increase the coin count without operating the coin counter.

**(b) Select switch**

In Test mode, flip this switch up or down to select an item or setting (value).

**(c) Test switch**

Turn this switch on to activate Test mode.

Test mode is used to test the monitor and other parts.

**(d) Enter button (green)**

After selecting an item or setting (value) with the select switch, press this button to enter or execute the selection.

## 7-5 Test Mode

### 7-5-1 Description of the MENU Screen

- 1** Unlock the service door with the supplied key and set the test switch to on. The MENU screen appears on the monitor.
- 2** Flip the select switch up or down to select an item. The selected item blinks.
- 3** Press the enter button to enter the selection.
- 4** When the selection is entered, the screen changes to the detailed information for the selected item.

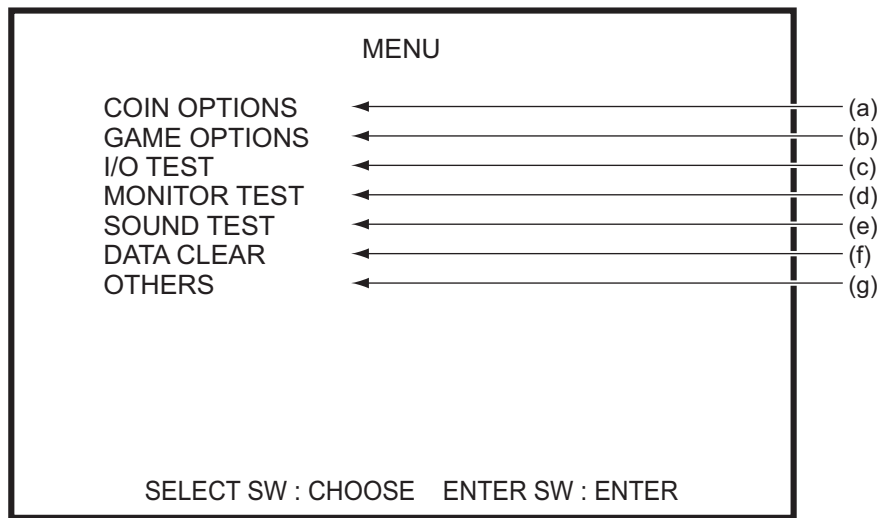

**MENU screen**

	Item	Description	Reference
(a)	COIN OPTIONS	Setting for the game cost, etc.	See 7-5-2
(b)	GAME OPTIONS	Communication settings.	See 7-5-3
(c)	I/O TEST	Test for the switches, lamps, etc.	See 7-5-4
(d)	MONITOR TEST	Test for the monitor.	See 7-5-5
(e)	SOUND TEST	Volume adjustment, etc.	See 7-5-6
(f)	DATA CLEAR	Individual initialization of each backup data item.	See 7-5-7
(g)	OTHERS	Settings for the time, language and emergency mode.	See 7-5-8

- 5** After completing all the settings, set the test switch to off.



- Before entering Test mode, make sure that any games being played on other machines that are connected by communication have finished. Otherwise the game being played may be affected.

## 7-5-2 Game Cost and Free Play Settings (COIN OPTIONS)

This screen is used to set the cost of each game.

- 1** In the MENU screen, select COIN OPTIONS and press the enter button. The COIN OPTIONS screen appears.
- 2** Flip the select switch up or down to select an item. The selected item blinks.
- 3** Press the enter button to enter the selection.
- 4** After entering the selection, use the select switch to change the item setting.

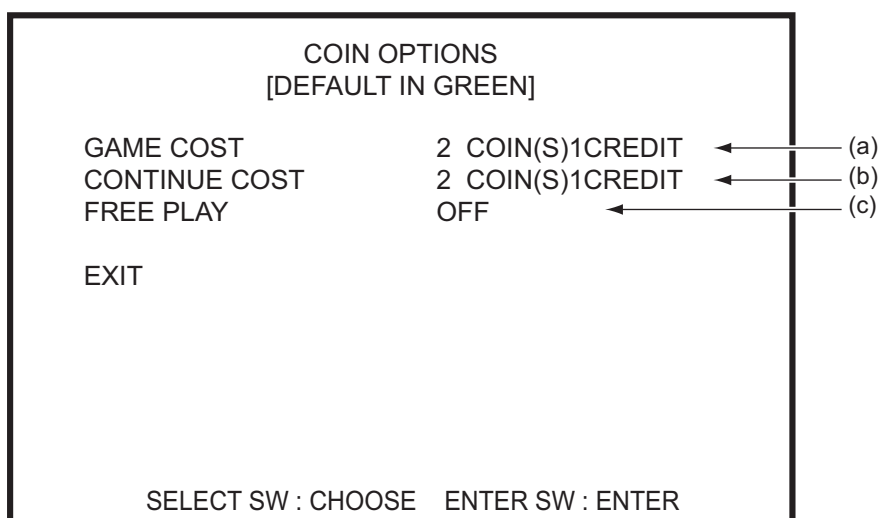

**COIN OPTIONS screen**

	Item	Description	Default
(a)	GAME COST	Setting for the number of coins required for a game Setting range: 1 to 19	4
(b)	CONTINUE COST *1	Setting for the number of coins required for a continue Setting range: 1 to 19	4
(c)	FREE PLAY	Free play setting OFF: Normal coin operation ON: Free play operation	OFF

\*1: CONTINUE COST cannot be set to a value higher than GAME COST.

- 5** After changing the setting, press the enter button to return to the item selection.
- 6** Select EXIT and press the enter button to return to the MENU screen.

### 7-5-3 Communication Settings (GAME OPTIONS)

This screen is used to set the communication.

- 1** In the MENU screen, select GAME OPTIONS and press the enter button. The GAME OPTIONS screen appears.
- 2** Flip the select switch up or down to select an item. The selected item blinks.
- 3** Press the enter button to enter the selection.
- 4** After entering the selection, use the select switch to change the item setting.

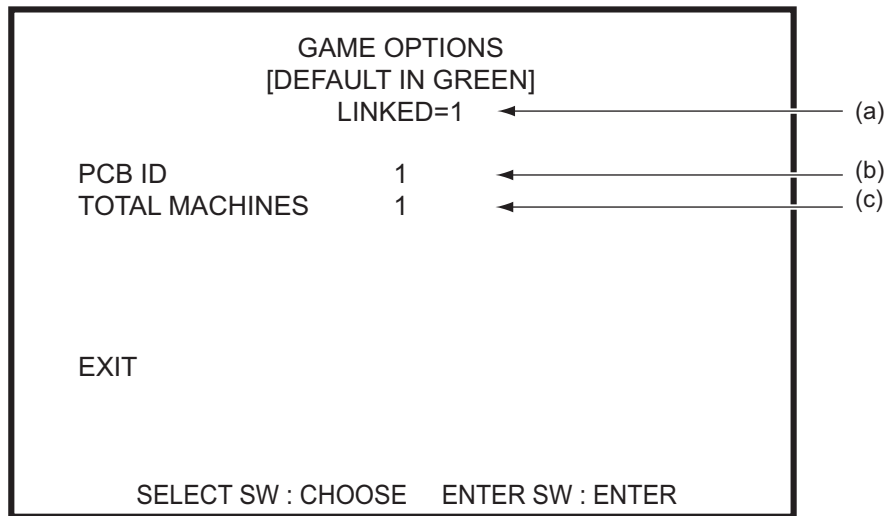

**GAME OPTIONS screen**

	Item	Description	Default
(a)	LINKED=	Communication status display LINKED= 4      4 machines are communicating normally. LINKED= 3      3 machines are communicating normally. LINKED= 2      2 machines are communicating normally. LINKED= 1      1 machine is communicating normally. LINKED= OFF    When communication is set, cannot communicate with other machines.	
(b)	PCB ID	Sets the ID of the PCB. Set the machines to 1 to 4 in order from the left as you face them. Setting range: 1 to 4	1
(c)	TOTAL MACHINES	Sets the number of machines to connect by communication. Setting range: 1 to 4	1

\* Caution: Make sure that the TOTAL MACHINES setting is the same value as the number of machines performing communication and is set to the same value in all the machines. Otherwise, communication will not be possible.

- 5** After changing the setting, press the enter button to return to the item selection.
- 6** Select EXIT and press the enter button to return to the MENU screen.

---

 **CAUTION**

- When connecting an additional machine to machines that are already communicating and in operation, first be sure to initialize the data of the additional machine by performing PROFILE INITIALIZE in Test mode. Otherwise, when you connect the additional machine to the machines that are in operation, the player data of the machines in operation may be deleted. The deleted data cannot be restored.

 **NOTICE**

- If you cannot activate communication for racing with other machines despite adjusting the various settings, turn off the power to all the machines, and then turn them all on again at the same time.

### 7-5-4 Testing the Switches and Lamps (I/O TEST)

This screen is used to test switches and other components.

- 1** In the MENU screen, select I/O TEST and press the enter button. The I/O TEST screen appears.
- 2** Flip the select switch up or down to select an item. The selected item blinks.
- 3** Press the enter button to enter the selection.
- 4** When the selection is entered, the screen changes to the detailed information for the selected item.

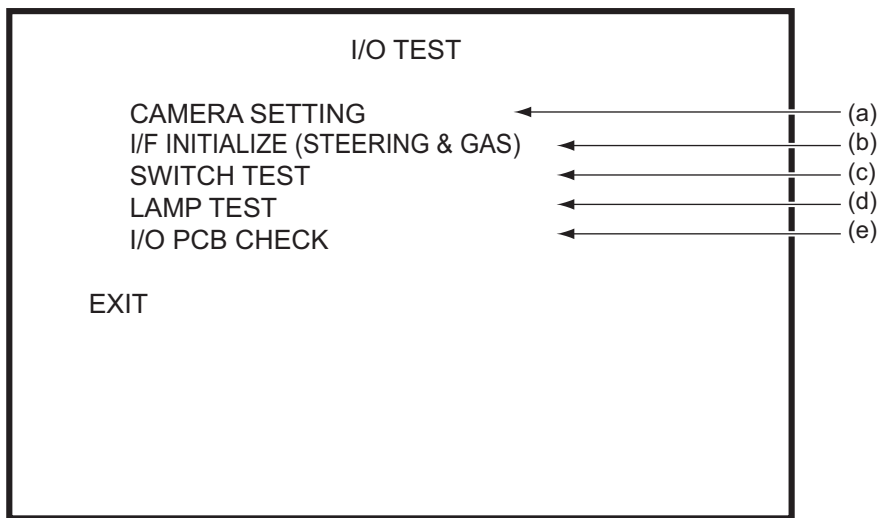

I/O TEST screen

	Item	Description
(a)	CAMERA SETTING	Adjusts the shooting position of the camera.
(b)	I/F INITIALIZE (STEERING & GAS)	Initializes the control parts (steering wheel, accelerator).
(c)	SWITCH TEST	Tests the various switches.
(d)	LAMP TEST	Tests the lamps.
(e)	I/O PCB CHECK	Checks the operating status of the NA-JV PC board (I/O PCB).

- 5** After completing all the settings, select EXIT and press the enter button to return to the MENU screen.



**(a) CAMERA SETTING**

This screen is used to adjust the shooting position of the camera.

- 1** In the I/O TEST screen, select CAMERA SETTING and press the enter button. The CAMERA SETTING screen appears.
- 2** Flip the select switch up or down to select an item. The selected item blinks.
- 3** When the enter button is pressed, the values changes in accordance with the item, which changes the camera shooting position little by little.

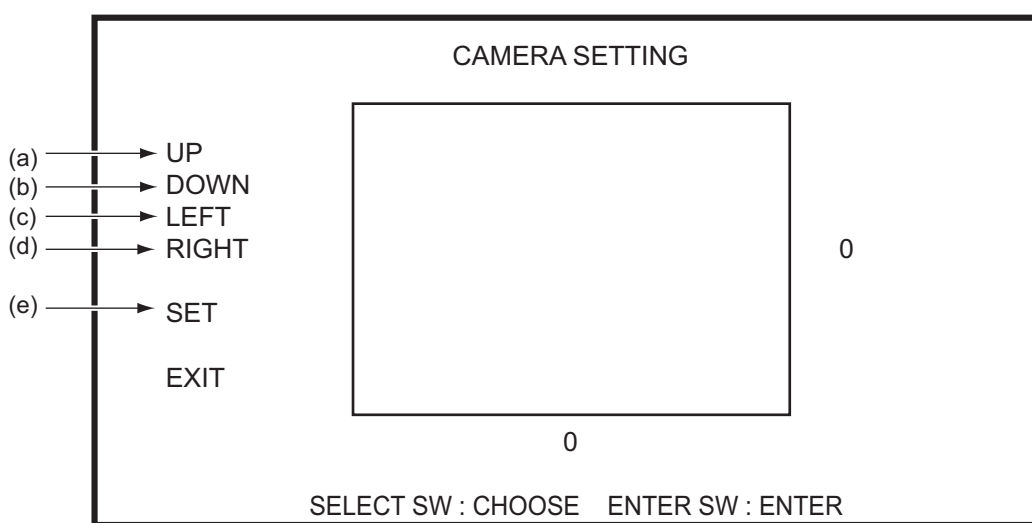

**CAMERA SETTING screen (1)**

- 4** To save the changes, select SET and press the enter button, and then select SAVE SETTING and press the enter button again.
- 5** Select EXIT and press the enter button to return to the I/O TEST screen.

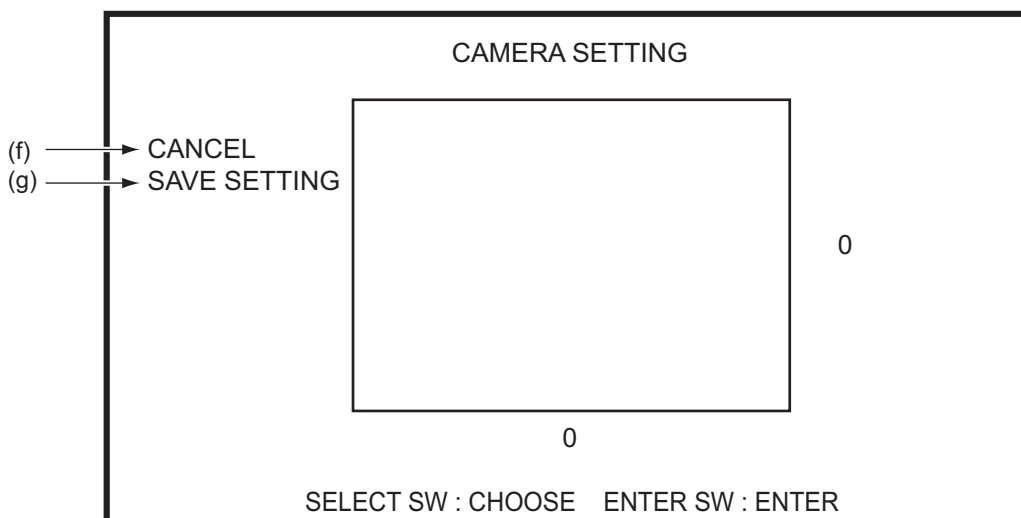

**CAMERA SETTING screen (2)**

	Item	Description
(a)	UP	Moves the camera shooting position up.
(b)	DOWN	Moves the camera shooting position down.
(c)	LEFT	Moves the camera shooting position to the left.
(d)	RIGHT	Moves the camera shooting position to the right.
(e)	SET	Temporarily saves the new shooting position.
(f)	CANCEL	Returns to MENU without saving the shooting position.
(g)	SAVE SETTING	Saves the new shooting position and returns to MENU.

**(b) I/F INITIALIZE (STEERING & GAS)**

This screen is used to initialize the control parts (steering wheel, accelerator).

**1** In the I/O TEST screen, select I/F INITIALIZE (STEERING & GAS) and press the enter button.

The I/F INITIALIZE (STEERING & GAS) screen appears.

**2** Perform STEP 1 to STEP 6 below to initialize.

STEP 1 : Turn the steering wheel completely to the left and press the View Change Button.

STEP 2 : Turn the steering wheel completely to the right and press the View Change Button.

STEP 3 : Center the wheel and press the View Change Button.

STEP 4 : Press the right pedal all the way in and press the View Change Button.

STEP 5 : Release the right pedal and press the View Change Button.

STEP 6 : Initialization complete. Select "SAVE SETTING" and to finish.

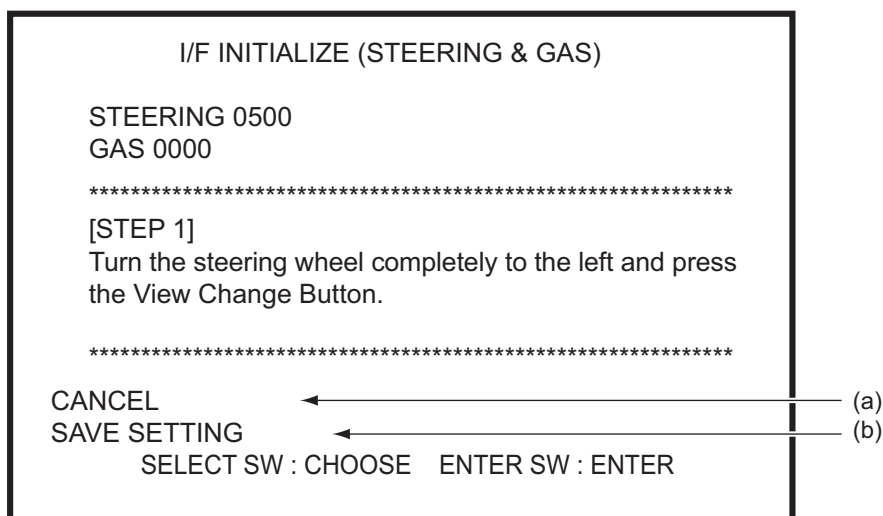

**I/F INITIALIZE (STEERING & GAS) screen**

	Item	Description
(a)	CANCEL	Returns to I/O TEST without saving the setting.
(b)	SAVE SETTING	Saves the setting.

**3** Select CANCEL to return to I/O TEST without saving the setting. Select SAVE SETTING to save the setting and proceed to SWITCH TEST.

**(c) SWITCH TEST**

This screen is used to test the various switches.

- 1** In the I/O TEST screen, select SWITCH TEST and press the enter button. The SWITCH TEST screen appears.
- 2** When the switches are turned ON, the entered items change.

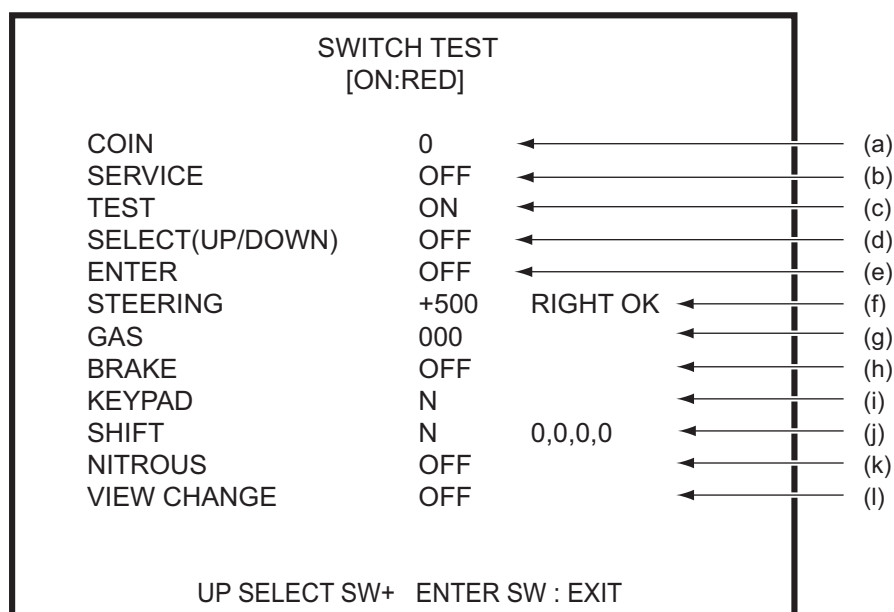

**SWITCH TEST screen**

	Item	Description
(a)	COIN	The count is increased by 1 each time the switch is set to ON. 0 to 999 (Returns to 0 after 999.)
(b)	SERVICE	OFF : Normal ON (red text) : While pressed
(c)	TEST	ON (red text) : Normal
(d)	SELECT(UP/DOWN)	UP : While flipped up DOWN : While flipped down
(e)	ENTER	OFF : Normal ON (red text) : While pressed
(f)	STEERING	The value changes in the + direction when turned to the right and in the – direction when turned to the left. Normal if +500 RIGHT OK is displayed when fully turned to the right and –500 LEFT OK is displayed when fully turned to the left.
(g)	GAS	The value changes when the accelerator pedal is depressed. Normal if +1000 OK is displayed when the pedal is fully depressed.
(h)	BRAKE	OFF : Normal ON (red text) : While fully depressed
(i)	KEYPAD	N : Normal 1 to 9, *, # (red text) : Displays the value that corresponds to the pressed key.
(j)	SHIFT	N, 1 to 4 (red text) : Displays the value that corresponds to the shift position. 0, 0, 0, 0 : Uses "0" or "1" to display the status of each switch being used with the shift.
(k)	NITROUS	OFF : Normal ON (red text) : While pressed
(l)	VIEW CHANGE	OFF : Normal ON (red text) : While pressed

\* Caution: If OK is not displayed in (f) or (g), perform 7-5-4 (b) I/F INITIALIZE (STEERING & GAS) on page 33.

- 3** While the select switch is flipped up, press the enter button to return to the I/O TEST screen.

**(d) LAMP TEST**

This screen is used to test the lamps.

- 1** In the I/O TEST screen, select LAMP TEST and press the enter button. The LAMP TEST screen appears.
- 2** Flip the select switch up or down to select an item. The selected item blinks.
- 3** Press the enter button to enter the selection, and switch between ON and OFF with the select switch. While ON is displayed, the lamp that corresponds to the item blinks.
- 4** Press the enter button to return to the item selection.

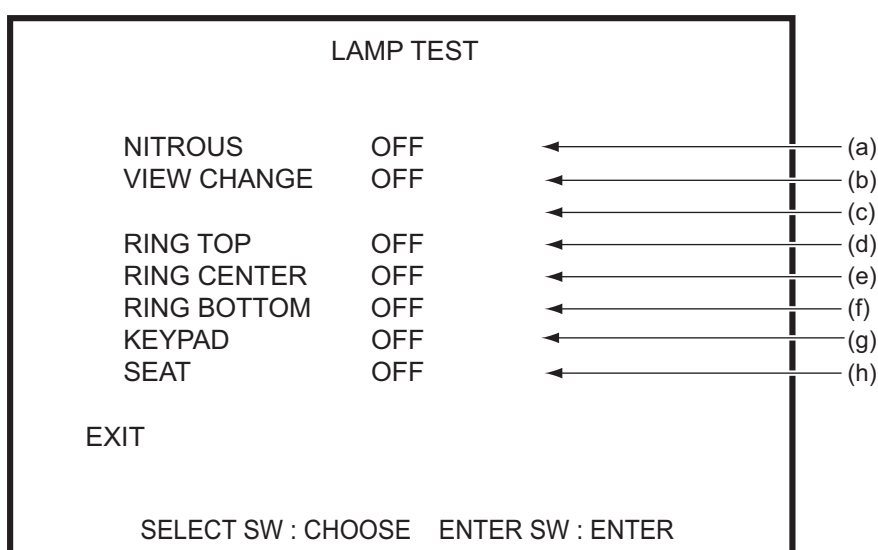

**LAMP TEST screen**

	Item	Description
(a)	NITROUS	When ON is selected, the built-in lamp of the NITROUS switch blinks.
(b)	VIEW CHANGE	When ON is selected, the built-in lamp of the VIEW CHANGE switch blinks.
(c)	RING TOP	When ON is selected, the RING TOP LED lamp blinks.
(d)	RING CENTER	When ON is selected, the RING CENTER LED lamp blinks.
(e)	RING BOTTOM	When ON is selected, the RING BOTTOM LED lamp blinks.
(f)	KEYPAD	When ON is selected, the KEYPAD LED lamp blinks.
(g)	SEAT	When ON is selected, the SEAT LED lamp blinks.

- 5** Select EXIT and press the enter button to return to the I/O TEST screen.

**(e) I/O PCB CHECK**

This screen is used to check the operating status of the NA-JV PC board (I/O PCB).

- 1** In the I/O TEST screen, select I/O PCB CHECK and press the enter button. The I/O PCB CHECK screen appears.

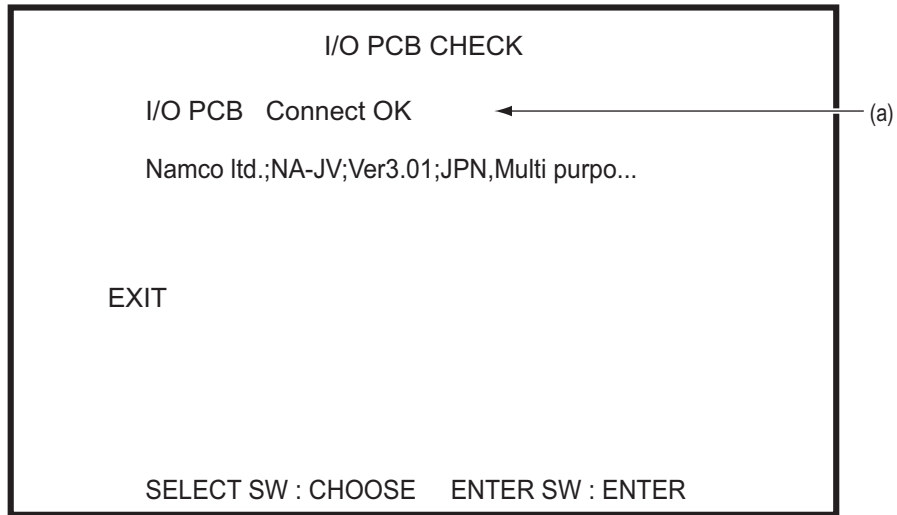

**I/O PCB CHECK screen**

Item	Item	Description
(a)	I/O PCB	Operations cannot be performed. CONNECT OK (green display) : Communicating normally. CONNECT NG (red display) : Not communicating normally.

- 2** Select EXIT and press the enter button to return to the I/O TEST screen.



### 7-5-5 Monitor Test (MONITOR TEST)

This screen is used for various monitor adjustments.

- 1** In the MENU screen, select MONITOR TEST and press the enter button. The MONITOR TEST screen appears.
- 2** Flip the select switch up or down to select an item. The selected item blinks.
- 3** Press the enter button on an item to display its pattern.

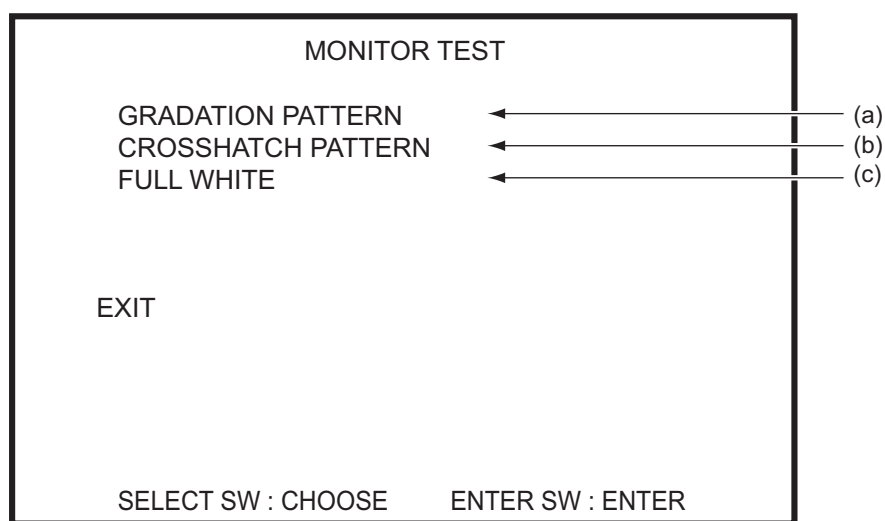

**MONITOR TEST screen**

Item	Item	Description
(a)	GRADATION PATTERN	Displays a gradation pattern. (16 levels)
(b)	CROSSHATCH PATTERN	Displays a pattern for checking screen positions.
(c)	FULL WHITE	Displays the whole screen in white.

- 4** Press the enter switch again to return to the MONITOR TEST screen.
- 5** Select EXIT and press the enter button to return to the MENU screen.

### 7-5-6 Sound Test (SOUND TEST)

This screen is used to perform volume adjustment, stereo checks and other settings.

- 1** In the MENU screen, select SOUND TEST and press the enter button. The SOUND TEST screen appears.
- 2** Flip the select switch up or down to select an item. The selected item blinks.
- 3** Press the enter button to enter the selection.
- 4** After entering the selection, use the select switch to change the item setting.

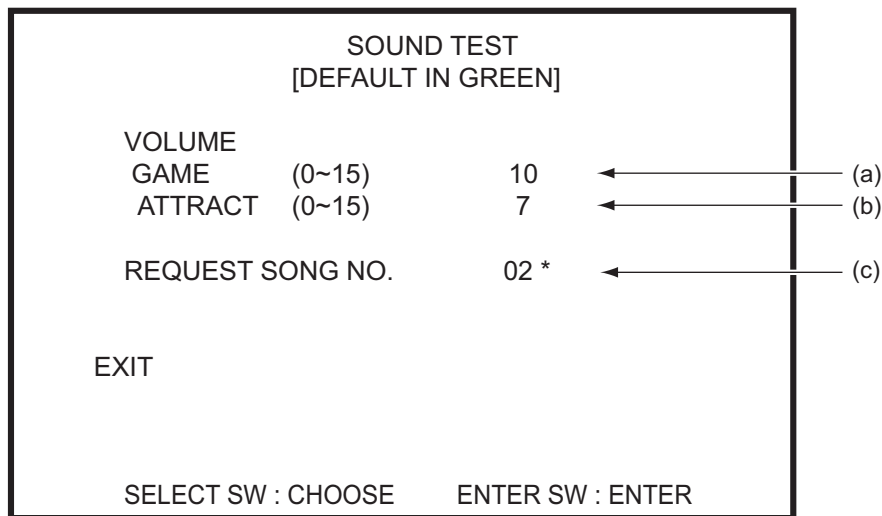

**SOUND TEST screen**

	Item	Description	Default
(a)	VOLUME GAME	Volume setting for Game mode. Setting range: 0 (min.) to 15 (max.) Flip up the select switch to increase the value. Flip down the select switch to decrease the value.	10
(b)	VOLUME ATTRACT	Volume setting for Attract mode. Setting range: 0 (min.) to 15 (max.) Flip up the select switch to increase the value. Flip down the select switch to decrease the value.	7
(c)	REQUEST SONG NO. *1	0: No sound 1: Stereo test 2: Sample song for Game mode Sound is played at the Game mode volume. 3: Sample song for Attract mode Sound is played at the Attract mode volume.	00

\*1: While the requested sound is played, “\*\*” is displayed on the right of the two-digit number.

- 5** After changing the setting, press the enter button to return to the item selection.
- 6** Select EXIT and press the enter button to return to the MENU screen.

### 7-5-7 Data Clear (DATA CLEAR)

This screen is used to initialize individual backup data items.

- 1** In the MENU screen, select DATA CLEAR and press the enter button. The DATA CLEAR screen appears.
- 2** Flip the select switch up or down to select an item. The selected item blinks.
- 3** Press the enter button to enter the selection.
- 4** When the selection is entered, the screen changes to the detailed information for the selected item.

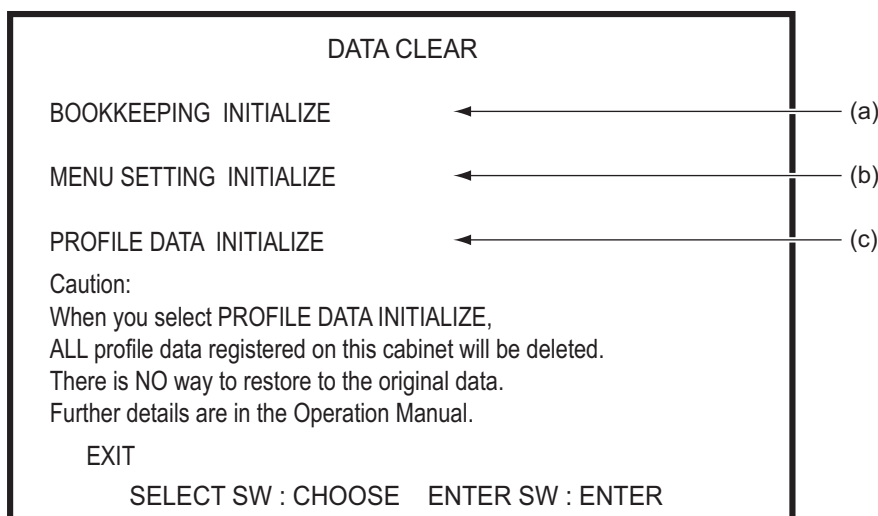

**DATA CLEAR screen**

	Item	Description
(a)	BOOKKEEPING INITIALIZE	Initializes the bookkeeping data that is stored in the machine. NO : (Do not initialize) YES : (Initialize)
(b)	MENU SETTING INITIALIZE	Initializes the following settings that are stored in the machine. • COIN OPTIONS setting • I/O INITIALIZE setting • I/F INITIALIZE setting • Sound settings • OTHERS settings NO : (Do not initialize) YES : (Initialize)
(c)	PROFILE DATA INITIALIZE	Initializes the player data that is stored in the machine. NO : (Do not initialize) YES : (Initialize)



- **When PROFILE DATA INITIALIZE is performed, all player data that was registered with a PIN is deleted.**  
\* **The deleted player data cannot be restored.**

- 5** After completing all the settings, select EXIT and press the enter button to return to the MENU screen.

### 7-5-8 Other (OTHERS)

This screen is used to set the language, clock and other items.

- 1** In the MENU screen, select OTHERS and press the enter button.  
The OTHERS screen appears.
- 2** Flip the select switch up or down to select an item. The selected item blinks.
- 3** Press the enter button on an item to display it.

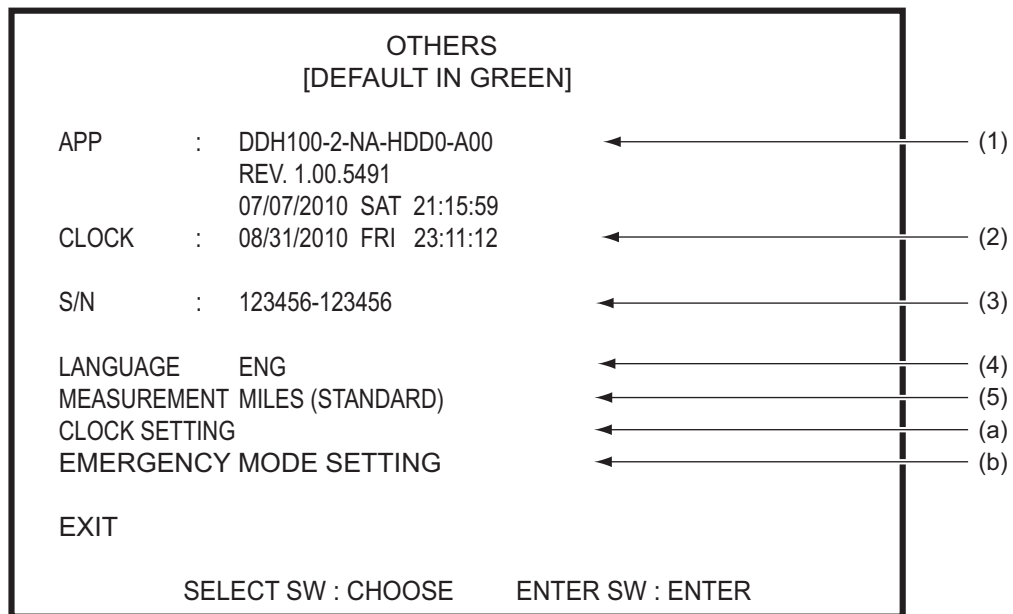

**OTHERS screen**

	Item	Description
(1)	APP	Displays the version of the program on the hard disk.
(2)	CLOCK	Displays the internal clock's current time and day of the week.
(3)	S/N	Displays the software serial number.
(4)	LANGUAGE	Language setting (Only ENG (English) is available in this product.)
(5)	MEASUREMENT	The displayed distance unit can be changed. • MILES (STANDARD) (default) • km (METRIC)
(a)	CLOCK SETTING	Sets the time of the internal clock.
(b)	EMERGENCY MODE SETTING	Used when a malfunction occurs.

- 4** Select EXIT and press the enter button to return to the MENU screen.

**(a) CLOCK SETTING**

This screen is used to set the time of the internal clock.

- 1** In the OTHERS screen, select CLOCK SETTING and press the enter button. The CLOCK SETTING screen appears.
- 2** Flip the select switch up or down to select an item. The selected item blinks.
- 3** Press the enter button on an item to enter the setting mode.

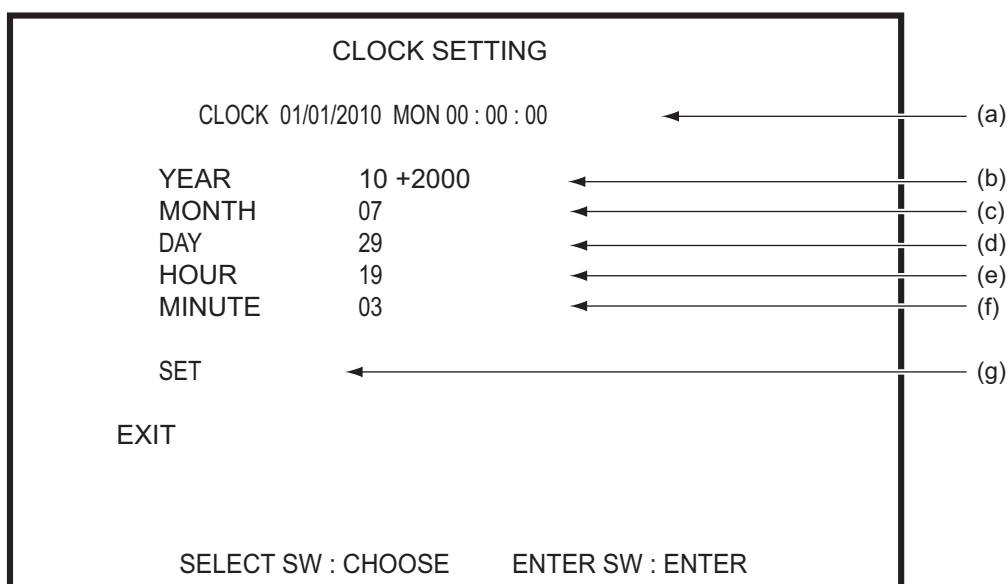
**CLOCK SETTING screen**

\* CLOCK SETTING can only be set on the machine connected by communication that has PCB ID set to "1."

Item	Item	Description
(a)	CLOCK	Displays the internal clock's current time and day of the week. (Cannot be selected)
(b)	YEAR	Sets the year of the internal clock. Setting range: 10 to 99
(c)	MONTH	Sets the month of the internal clock. Setting range: 01 to 12
(d)	DAY	Sets the day of the internal clock. Setting range: 01 to 31
(e)	HOUR	Sets the hour of the internal clock. Setting range: 00 to 23
(f)	MINUTE	Sets the minute of the internal clock. Setting range: 00 to 59
(g)	SET	Sets the time The internal clock is updated with the YEAR to MINUTE values.

- 4** After completing all the settings, select SET to save the settings.
- 5** After saving the settings, select EXIT and press the enter button to return to the MENU screen.

**(b) EMERGENCY MODE SETTING**

This screen is used when there is a steering power feedback malfunction or camera malfunction.

- 1** In the OTHERS screen, select EMERGENCY MODE SETTING and press the enter button.  
The EMERGENCY MODE SETTING screen appears.
- 2** Flip the select switch up or down to select an item. The selected item blinks.
- 3** Press the enter button on an item to enter the setting mode.

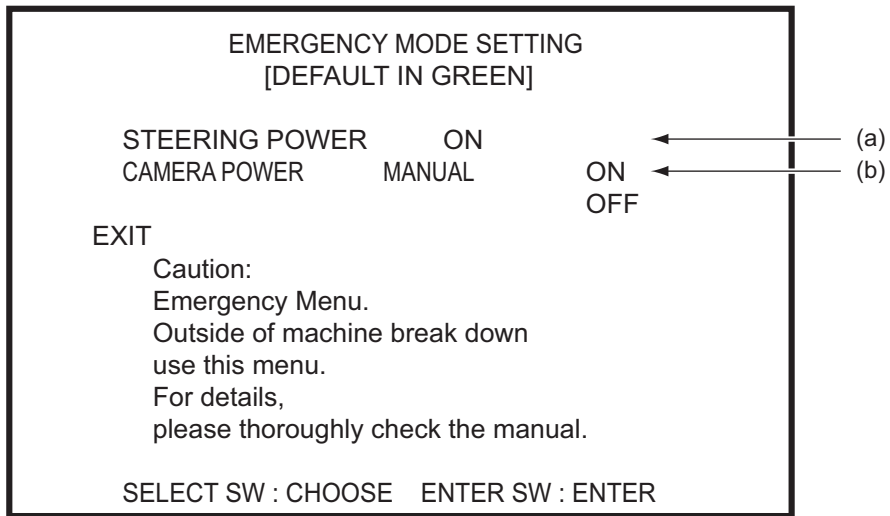

**EMERGENCY MODE SETTING screen**

	Item	Description	Default
(a)	STEERING POWER	Use when there is a steering power feedback malfunction. The game can be played without using the steering power feedback. ON : Use steering power feedback OFF : Do not use steering power feedback	ON
(b)	CAMERA POWER	Use when there is a camera malfunction. The game can be played without using the camera function. AUTO : Select ON or OFF by automatically checking for a camera connection. MANUAL : Set ON or OFF manually. ON : (The game can be played using the camera.) OFF : (The game cannot be played using the camera.) * ON cannot be selected if the camera is broken or cannot be recognized.	AUTO ON

- 4** After completing all the settings, select EXIT and press the enter button to return to the MENU screen.

---

**MEMO**

## 8A. Installation and Assembly

### 8A-1. Assembly

#### 8A-1-1 Installing the Signboard Assembly

#### WARNING

- The signboard assembly is installed while standing in a high location. Use a stool or similar platform. Working in an unnatural body posture may cause injury or machine damage.

- 1** On the top of the front assembly, install two torx bolts (M5 x 16) until the bolt heads protrude by approx. 0.1”.
- 2** Temporarily attach signboard stay (R) and signboard stay (L) to the torx bolts installed in step **1**, and then fully tighten the stays with the torx bolts installed in step **1** and two more torx bolts (M5 x 16).

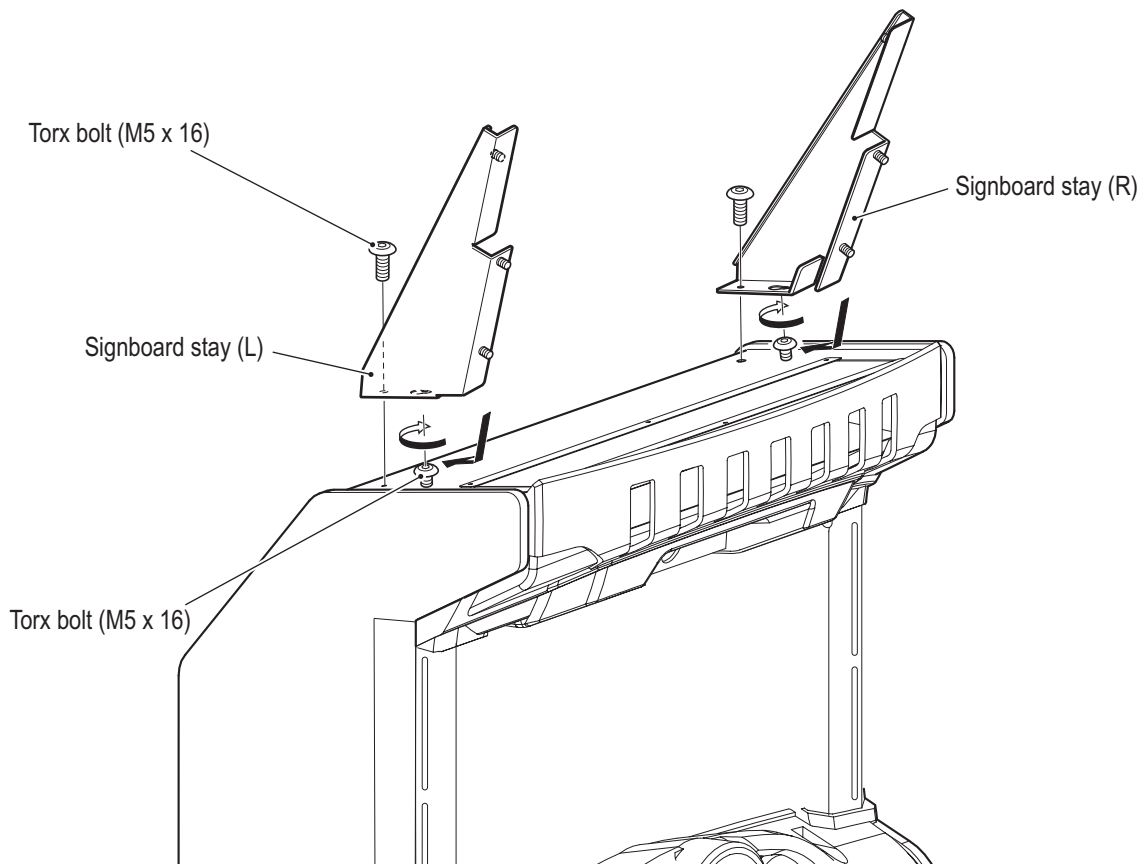



— Must be performed by a technician —

- 3** Fit title panel B onto signboard stay (R) and signboard stay (L), pass the upper side of the stud bolts through title panel B, and then fasten with two flat washers ( $\varnothing 5.5 \times 16 \times t1.6$ ) and hexagon cap nuts (M5).
- 4** Fit title panel F onto the lower side of the stud bolts on signboard stay (R) and signboard stay (L), and then fasten with four flat washers ( $\varnothing 5.5 \times 16 \times t1.6$ ) and hexagon cap nuts (M5).

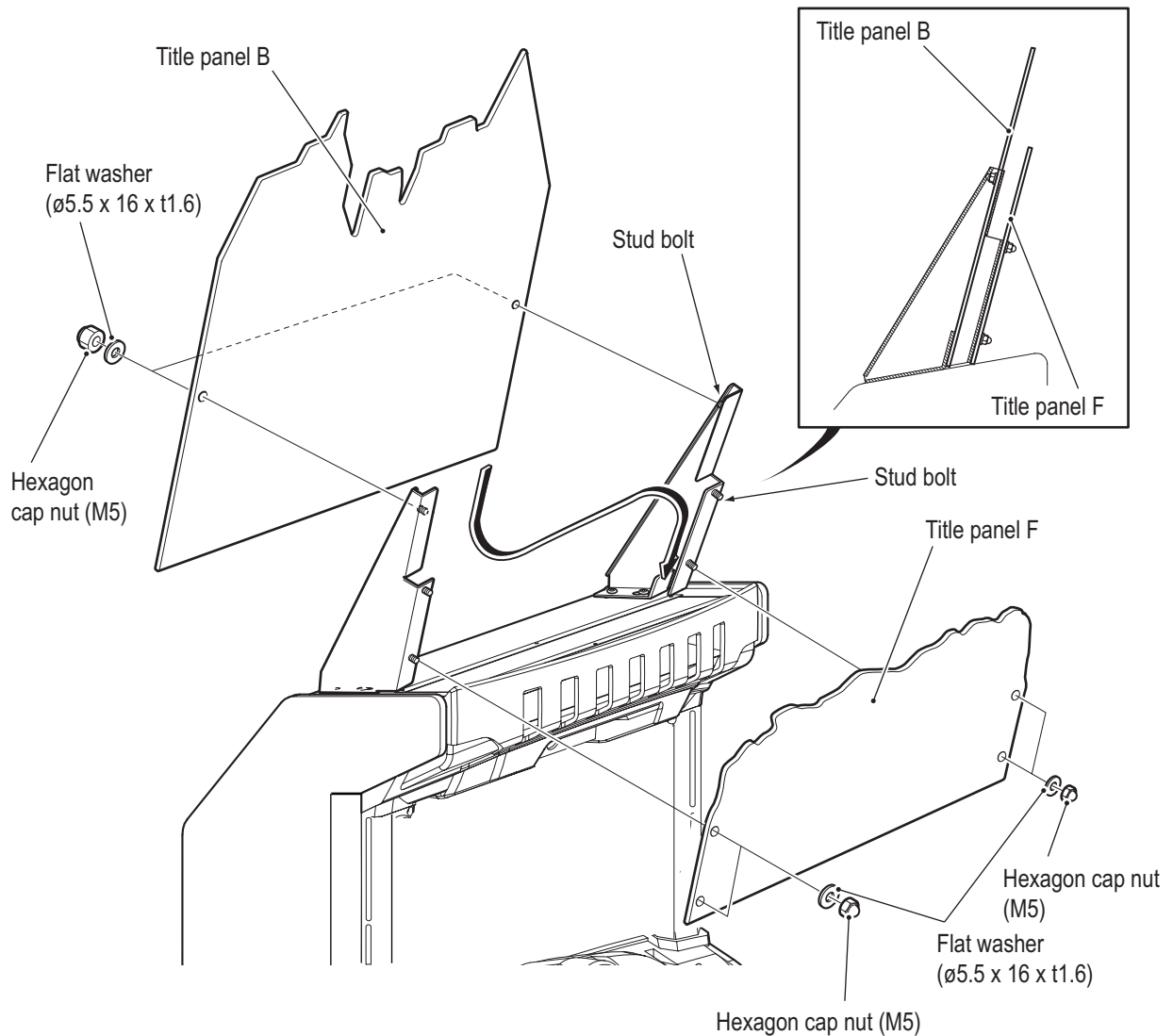

- 5** To remove, perform the procedure in reverse.

— Must be performed by a technician —

### 8A-1-2 Connecting the Front Assembly to the Seat Assembly and Level Adjuster Adjustment

- 1 The joint brackets for the seat are shipped inside the front assembly as shown in the figure on the left. Loosen the bolt retaining the bracket, remove the bracket and rotate it so the narrow slot is facing forward (away from the seat) as shown in the figure on the right. Then tighten the bolt and add a second bolt from the spare parts kit as shown. For ease of installation, the bolts (M8X25 Hex head) may be installed by hand leaving a gap slightly larger than thickness of the bracket and then the bracket can be installed by placing the large holes of the bracket over the bolts and then sliding the bracket as shown toward the player. Once in place tighten using a ratchet wrench.

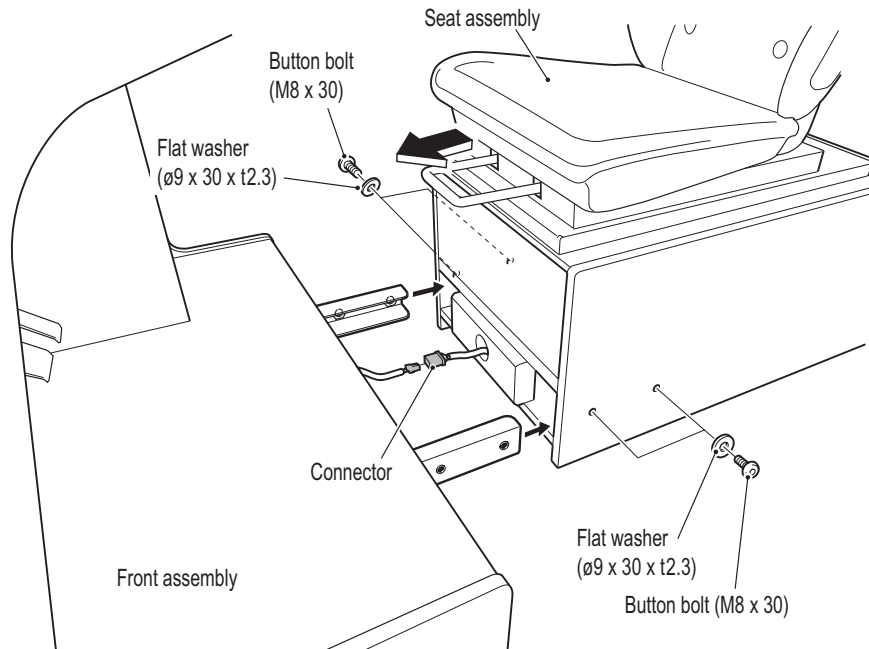
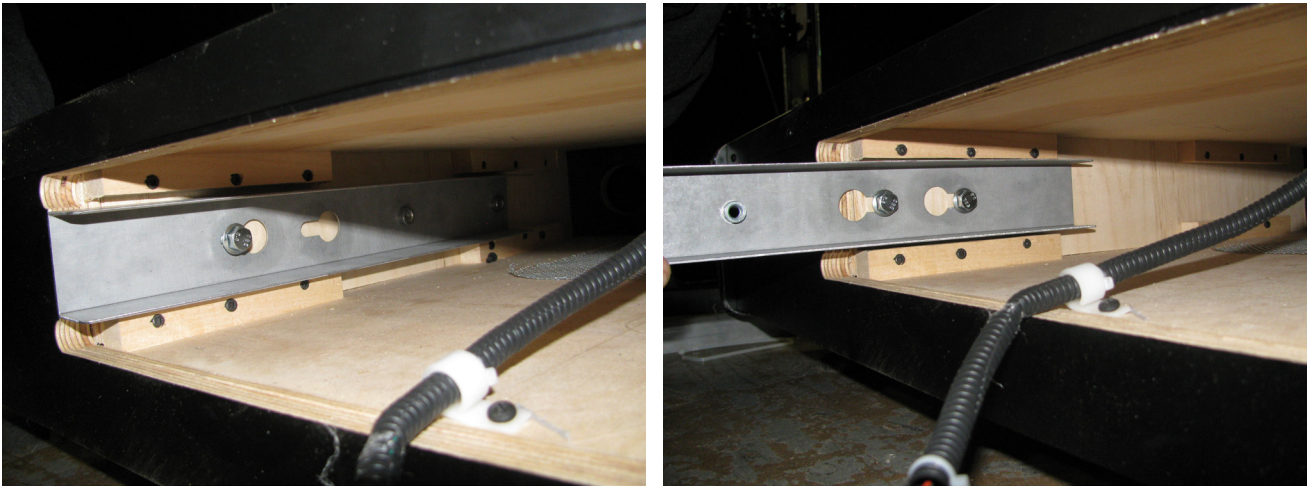

- 2 Place the seat assembly near the front assembly, and pull out one of the connectors from inside the front assembly.
- 3 Pull out one of the connectors from inside the seat assembly, and connect it to the connector from step 2.
- 4 Insert the joint bracket into the seat assembly. While connecting these parts, be careful not to pinch the connectors or harness.

— Must be performed by a technician —

- 5** From the side surfaces of the seat assembly, fasten the seat assembly to the front assembly with two flat washers ( $\varnothing 9 \times 30 \times t2.3$ ) on each side (four in total) and two button bolts (M8 x 30) on each side (four in total).
- 6** Lower the level adjusters until the casters are at a height of approx. 0.2" from the floor.  
(Two on the front assembly and two on the seat assembly; four in total.)

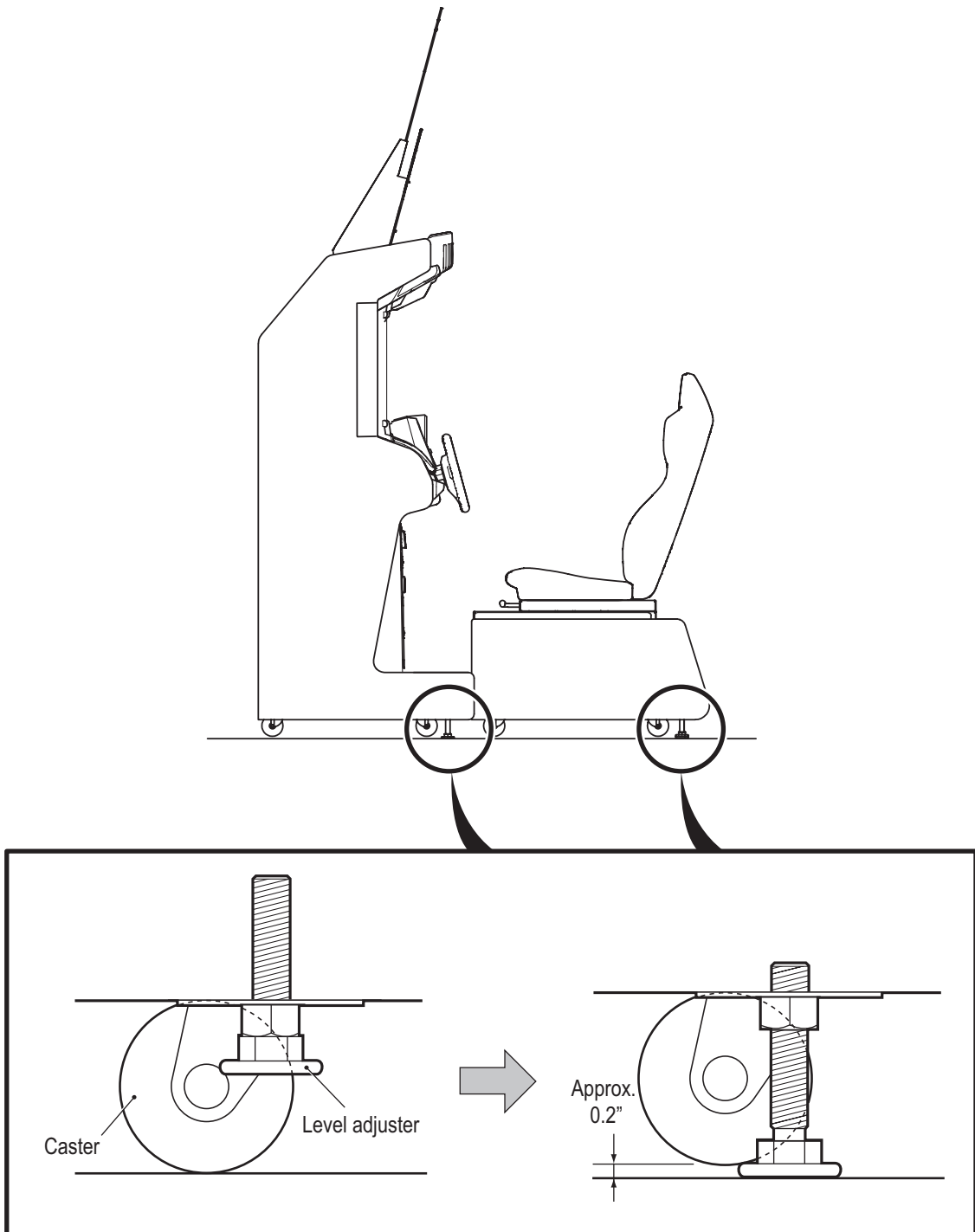

— Must be performed by a technician —

### 8A-1-3 Connecting Two Machines for Communication

Two to four machines can be connected for operation.

When connecting three or four machines, see “8A-1-4 Connecting Three or Four Machines for Communication” on page 53.

\* When operating only one machine, the following procedure is not required.

Go to “8A-1-5 Connecting the Power Cord and Ground” on page 55.

#### CAUTION

- Lay out the communication cables safely so they will not cause players, bystanders or passersby to trip over them.
- When connecting an additional machine to machines that are already communicating and in operation, first be sure to initialize the data of the additional machine by performing PROFILE INITIALIZE in Test mode. Otherwise, when you connect the additional machine to the machines that are in operation, the player data of the machines in operation may be deleted. The deleted data cannot be restored.

#### (1) Connection Diagram

Connect using one of the supplied communication cables, as shown in the figure below.

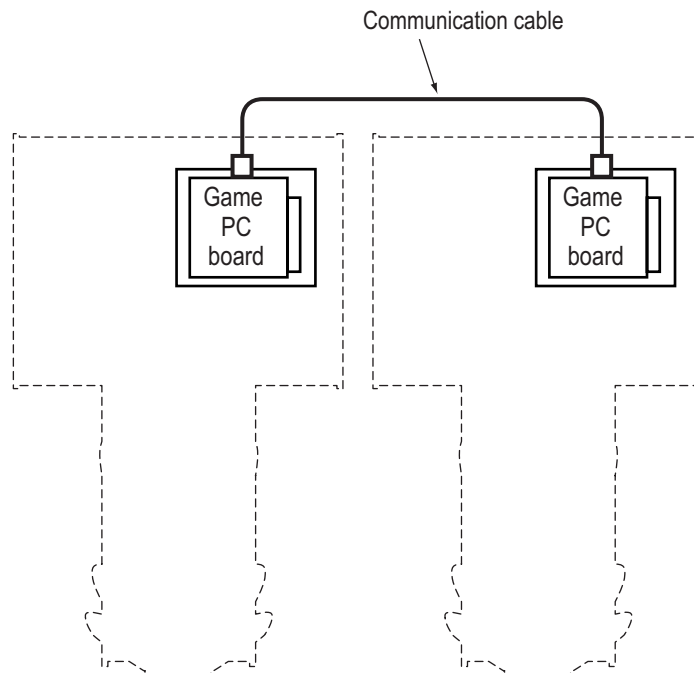

— Must be performed by a technician —

## (2) Connection Method

- 1** Remove the two torx bolts (M5 x 30) from the rear of the front assembly, and then unlock the rear door with the service key and remove it.

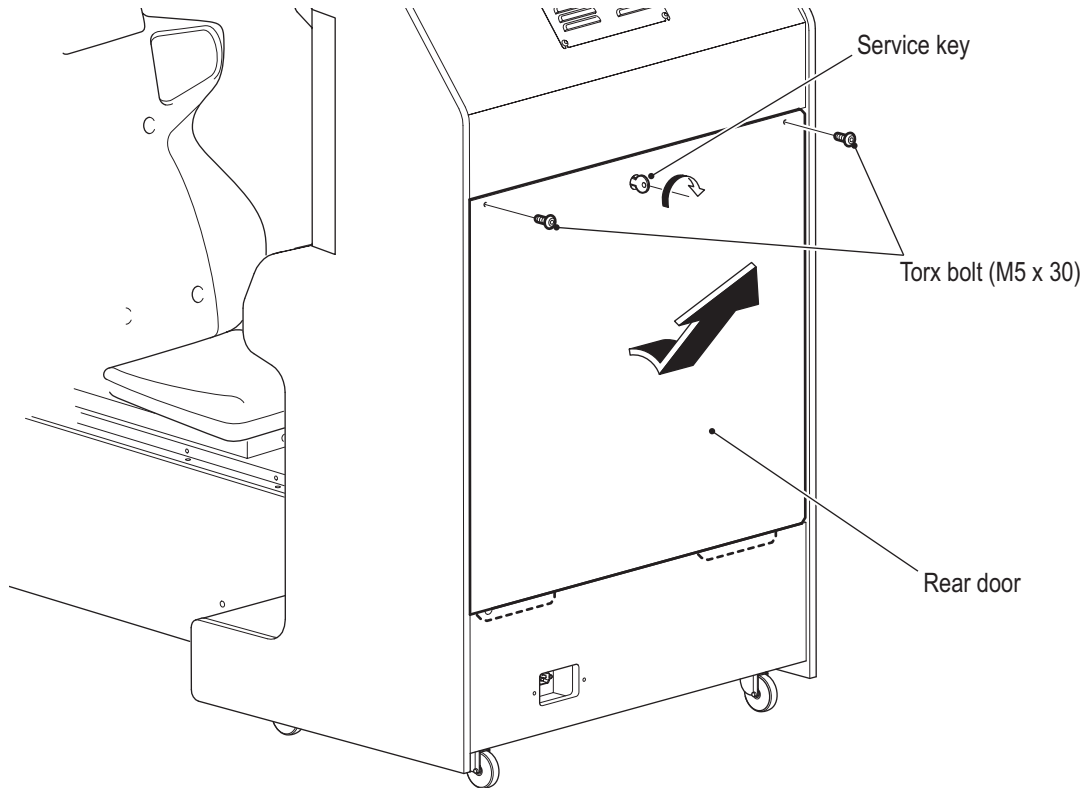

- 2** Connect the supplied communication cable to the SYS ES1 (B) assembly.

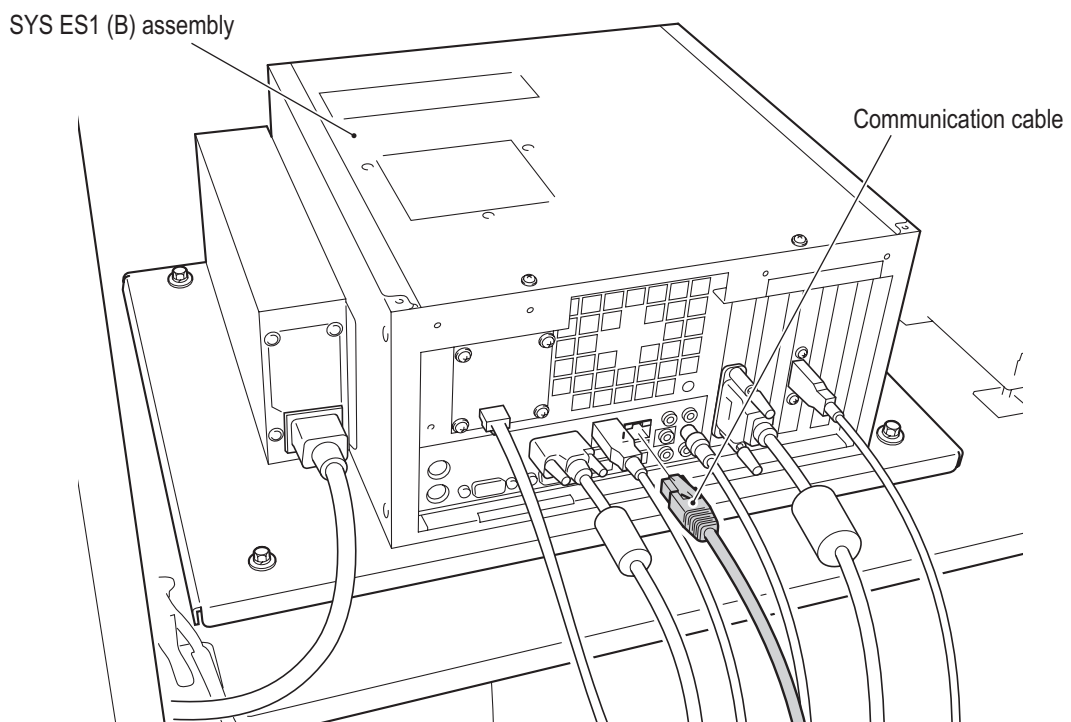

— Must be performed by a technician —

---

- 3 Position the communication cable in the U-shaped cut-out on the lower panel, and return the rear door to its original position.

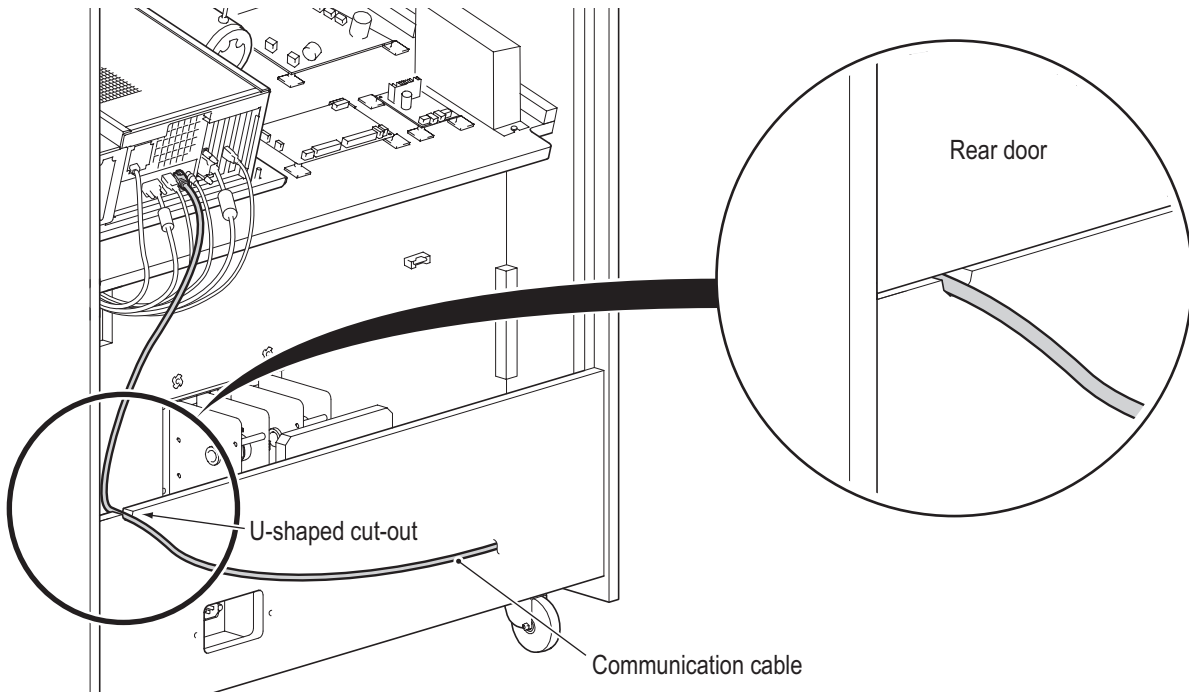

- Make sure that the communication cable is not crushed by the rear door.

- 4 Connect to the other machine using the same procedure.

— Must be performed by a technician —

## 8A-1-4 Connecting Three or Four Machines for Communication

When connecting two machines, see “8A-1-3 Connecting Two Machines for Communication” on page 50.

\*When operating only one machine, the following procedure is not required.  
Go to “8A-1-5 Connecting the Power Cord and Ground” on page 55.

### ⚠ CAUTION

- Lay out the communication cables safely so they will not cause players, bystanders or passersby to trip over them.
- When connecting an additional machine to machines that are already communicating and in operation, first be sure to initialize the data of the additional machine by performing PROFILE INITIALIZE in Test mode. Otherwise, when you connect the additional machine to the machines that are in operation, the player data of the machines in operation may be deleted. The deleted data cannot be restored.

#### (1) Connection Diagram

Connect using the four supplied communication cables and a hub (sold separately), as shown in the figure below.

(This is not required when operating only one machine or when connecting two machines for racing.)

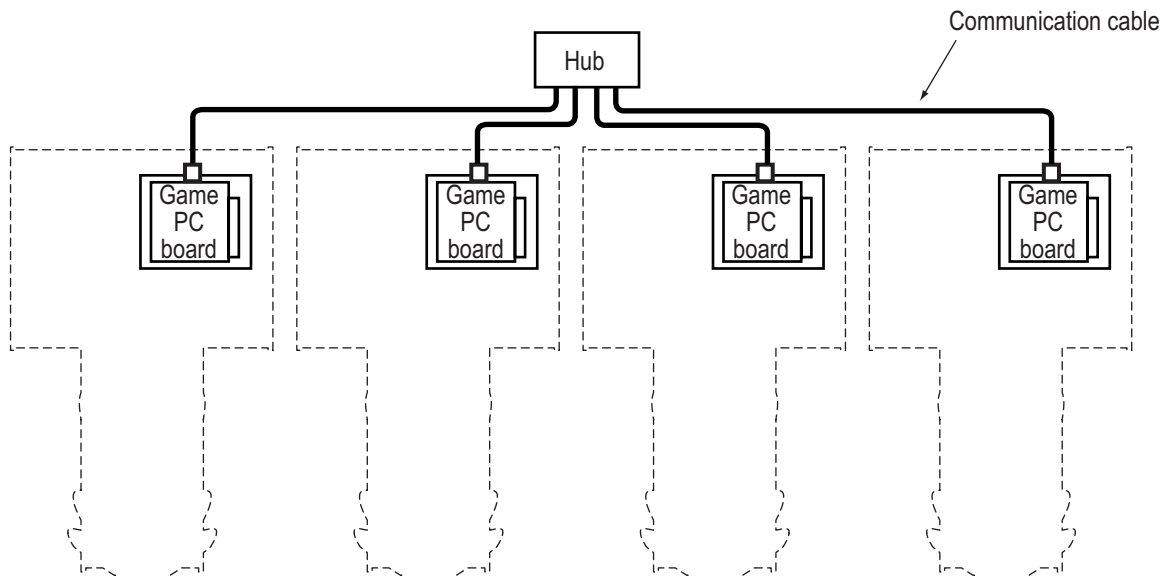

— Must be performed by a technician —

---

(2) Connection Method

- 1** Connect the supplied communication cables to the game PC board of each machine.  
(See **1** to **3** in “8A-1-3 (2) Connection Method” on page 51.)
- 2** Connect the other end of all the communication cables to the hub (sold separately).  
(See page 53.)
- 3** Insert the AC adapter that is supplied with the hub into the outlet, and check that the POWER lamp turns on.



- See the hub instructions for details on handling the hub.
- To ensure that water, wax or other substances do not adhere to the hub, use the magnets supplied with the hub to affix it to the rear or bottom panel of the machine. Do not place the hub on the floor.
- Turn on the power to the hub before or at the same time as the power to the machines. If the power is turned on in the incorrect order, communication will not be performed correctly. In such cases, turn off the power to the machines, check that the power lamp of the hub is on, and then turn on the power to the machines again.
- After connecting the machines, be sure to perform “8A-1-7 Communication Settings” on page 57.



— Must be performed by a technician —

### 8A-1-5 Connecting the Power Cord and Ground

#### WARNING

- Be sure to install the ground wire using one of the methods below. Failure to install the ground wire may result in electric shock. Connect the ground using a 3P plug.

- 1** Insert the socket side of the power cord into the power input of the cord box assembly on the bottom of the monitor assembly rear panel.

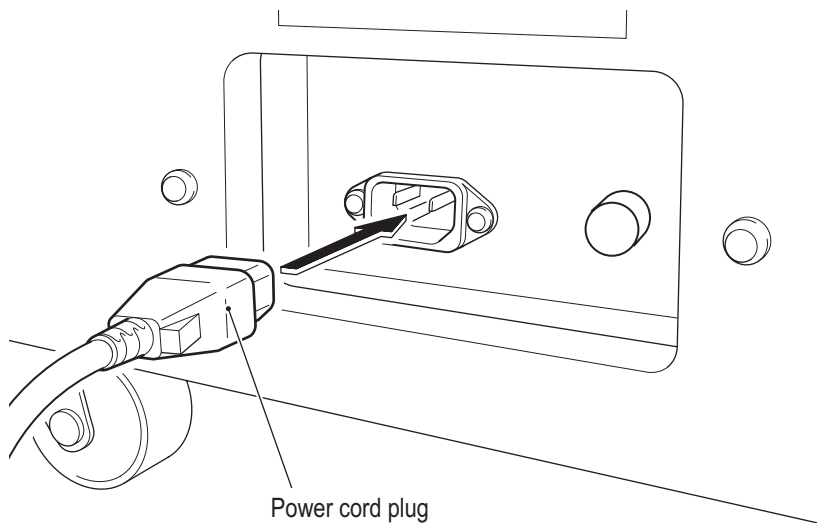

- 2** Insert the power plug of the power cord into the outlet.

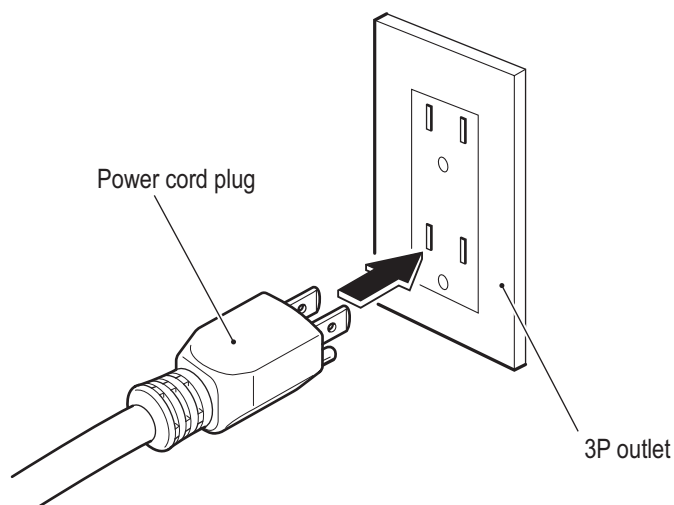

— Must be performed by a technician —

### 8A-1-6 Power Switch Position and Turning the Power Switch On

- 1 Turn on the power switch of the machine.

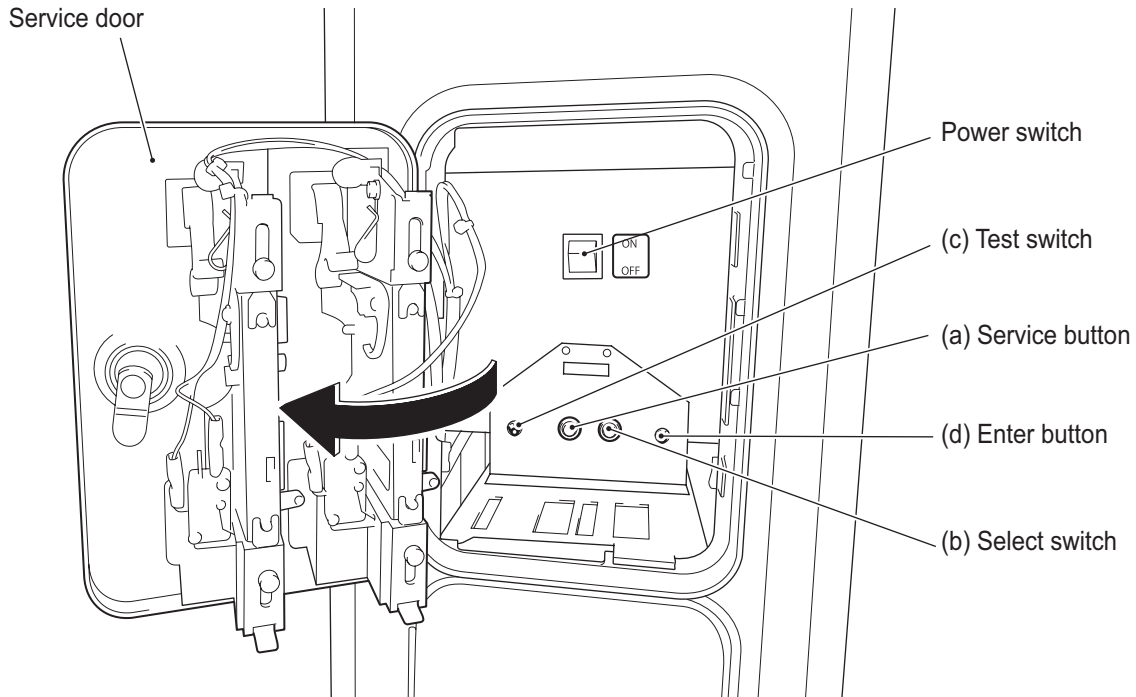

- Do not turn the power switch on and off repeatedly, because it may cause a machine malfunction.
- When turning the power switch off and on, wait 30 seconds or more between operations.
- Perform “7-5-3 Communication Settings (GAME OPTIONS)” on page 28 and “7-5-4 (b) I/F INITIALIZE (STEERING & GAS)” on page 33.

— Must be performed by a technician —

## 8A-1-7 Communication Settings

Two to four machines can be connected for racing play.

\* Perform these settings even when operating only one machine.

When using two to four machines for racing play, connect them with the communication cables. (See “8A-1-3 Connecting Two Machines for Communication” on page 50 and “8A-1-4 Connecting Three or Four Machines for Communication” on page 53.)

- 1** Turn on the power switch. (See “8A-1-6 Power Switch Position and Turning the Power Switch On” on page 56.)
- 2** Press the test switch to display the MENU screen.  
(See “7-5-1 Description of the MENU Screen” on page 26.)
- 3** Press the service button to select GAME OPTIONS, and press the test switch to display the GAME OPTIONS screen.

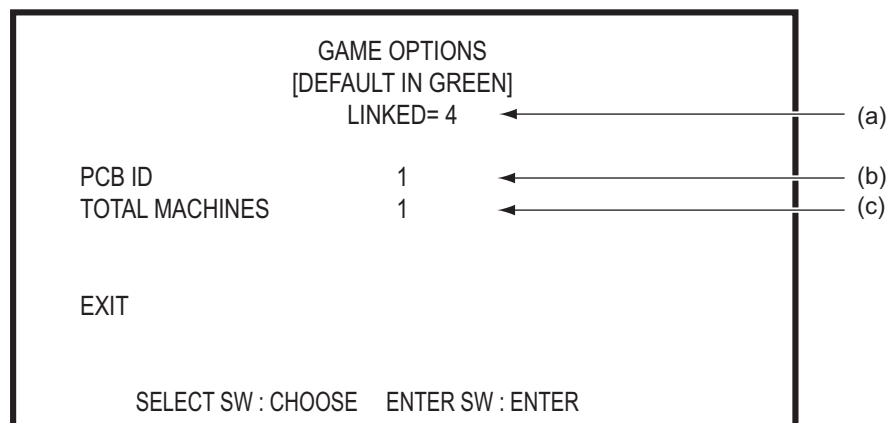

**GAME OPTIONS screen**

- 4** Set (b) PCB ID of the machines to 1 to 4 in order from the left as you face them.
- 5** Set (c) TOTAL MACHINES to the number of connected machines.
- 6** Check that the communication status (a) is as follows.
  - When two machines are installed: LINKED = 2
  - When three machines are installed: LINKED = 3
  - When four machines are installed: LINKED = 4
- 7** Select EXIT and press the enter button to return to the MENU screen.
- 8** Set the test switch to off to return to the game screen.



- If you cannot activate communication despite adjusting the various settings, turn off the power to all the machines, and then turn them all on again at the same time.  
The communication status can be checked with “Communication ready for max. X machines” (X is the number of communicating machines) that is displayed in the top left of the title screen.
- Make sure that any games being played on other machines that are connected by communication have finished before turning the power switch off. Otherwise the game being played may be affected.

— Must be performed by a technician —

---

 **CAUTION**

- **Make sure that the TOTAL MACHINES setting is the same value as the number of machines performing communication and is set to the same value in all the machines. Otherwise communication will not be possible.**
- **Turn on the power to the hub before or at the same time as the power to the machines. If the power is turned on in the incorrect order, communication will not be performed correctly. In such cases, turn off the power to the machines, check that the power lamp of the hub is on, and then turn on the power to the machines again.**
- **When connecting an additional machine to machines that are already communicating and in operation, first be sure to initialize the data of the additional machine by performing PROFILE INITIALIZE in Test mode. Otherwise, when you connect the additional machine to the machines that are in operation, the player data of the machines in operation may be deleted. The deleted data cannot be restored.**

# 8B. Service

---

## WARNING

- To avoid electric shock, accidents or injuries to yourself or other people, be sure to turn off the power switch before performing service work (such as repairs or correcting malfunctions).

## 8B-1 Inspections and Service

### WARNING

- Perform periodic service. Failure to perform service may result in an accident.
- Perform the inspections every day before starting operations. These are required to prevent accidents.  
(See “7-2 Pre-operation Inspection” on page 20.)

### 8B-1-1 Inspection Items

After performing “7-2 Pre-operation Inspection” on page 20, check the following items periodically for any abnormalities.

#### (1) Level Adjuster Inspection

1. Check that the level adjusters are fixed securely. (See “8A-1-2 Connecting the Front Assembly to the Seat Assembly and Level Adjuster Adjustment” on page 48.)

#### (2) Power Cord Plug Inspection

1. Check that the power cord is firmly inserted into the machine’s cord box and the power outlet.
2. Clean any dust or other dirt from the connection parts.
3. Check for cracks or dirt on the power cord covering. If there is any abnormality on the power cord, be sure to replace it.

#### (3) Screw Looseness Inspection

Check the following parts for looseness. Fully retighten any loose parts.

1. Flange brackets (M8 x 30) for fastening the steering assembly  
(See “8B-4-1 (5) Replacing the Steering Assembly” on page 72.)
2. Button bolts (M6 x 20) for fastening the pedal assembly  
(See “8B-4-3 (1) Removing and Installing the Pedal Assembly” on page 86.)
3. Button bolts (M5 x 12) for fastening the slide unit  
(See “8B-4-4 (1) Replacing the Slide Unit” on page 87.)

— Must be performed by a technician —

## 8B-2 Troubleshooting

### WARNING

- To avoid electric shock, accidents or injuries to yourself or other people, or damage to the electronic circuits, be sure to turn off the power switch before starting work.
- If the problem is not described in “8B-2 Troubleshooting” or the problem persists despite taking the appropriate action, turn off the power switch immediately to stop operations and contact your distributor. Continuing operations may result in an accident.

### NOTICE

- If a malfunction occurs, first make sure that all the connectors are connected securely.
- Repair of the PC boards will be performed by your distributor, so never perform a continuity check of a board with a tester or any other tool. The IC may be damaged by the internal voltage of the tester.
- To order repairs or parts, contact your distributor.
- When sending parts for repair, be sure to pack them properly. Particularly when sending the SYS ES1 (B) assembly, wrap the part in sponge or air bubble wrapping before packing it in a cardboard box. Make sure that the box is not exposed to outside pressure.

### 8B-2-1 General

Symptom	Cause	Action	Reference
• The machine does not start.	• A connector is disconnected.	• Insert the connector securely.	Page 79
	• A SYS ES1 (B) assembly malfunction.	• Replace the SYS ES1 (B) assembly. Contact your distributor.	Page 79
• Operation is not stable or the machine operates incorrectly.	• The power supply voltage is not in the range of AC 110 V to 130 V.	• Disconnect a high-capacity device (such as an air conditioner or large machine) from the same line to reduce the voltage to the specified power supply voltage.	Page 2
• The power turns off during operation.	• The circuit protector has operated to turn the power switch off. * The circuit protector turns off the current when an abnormal current occurs.	• Turn on the power switch again. If the circuit protector operates frequently, there is a mechanical abnormality. Contact your distributor.	Pages 24 and 56
• Resetting is performed during startup.	• The internal battery of the SYS ES1 (B) assembly has run out.	• Replace the SYS ES1 (B) assembly. Contact your distributor.	Page 79
	• A SYS ES1 (B) assembly malfunction.		

— Must be performed by a technician —

**8B-2-2 Front Assembly**

Symptom	Cause	Action	Reference
• Sound is not output from the speakers.	• The volume setting is low.	• Reset the volume.	Page 40
	• A connector or Faston terminal is disconnected.	• Insert the connector or Faston terminal securely.	Page 79
	• An amp PC board malfunction.	• Replace the amp PC board.	Page 83
• The monitor screen does not operate.	• A connector is disconnected.	• Insert the connector securely.	Page 68
	• A monitor malfunction.	• Replace the monitor.	Page 68
• The fluorescent lamp does not turn on.	• A connector is disconnected.	• Insert the connector securely.	Page 65
	• The fluorescent lamp has burned out.	• Replace the fluorescent lamp.	Page 65
• The view selector or NITROUS switch does not function.	• A connector is disconnected.	• Insert the connector securely.	Page 67
	• A switch malfunction.	• Replace the switch.	Page 67
	• A disconnection in the harness.	• Connect the location of the disconnection.	_____
• The lamp of the view selector or NITROUS switch does not turn on.	• A connector is disconnected.	• Insert the connector securely.	Page 67
	• The lamp has burned out.	• Replace the lamp.	Page 67
	• A disconnection in the harness.	• Connect the location of the disconnection.	_____

**8B-2-3 Steering Assembly**

Symptom	Cause	Action	Reference
• The steering does not function.	• The volume has not been initialized.	• Perform initialization.	Page 33
	• A connector is disconnected.	• Insert the connector securely.	Page 72
	• A steering assembly malfunction.	• Replace the steering. Contact your distributor.	Page 72
	• The fuse (5A) has burned out. * The fuse blows when an abnormal current occurs.	• Replace the fuse. If the fuse blows frequently, there is a mechanical abnormality. Contact your distributor.	Page 85

— Must be performed by a technician —

### 8B-2-4 Shift Assembly

Symptom	Cause	Action	Reference
• The shift lever does not function.	• A connector is disconnected.	• Replace the connector.	Page 74
	• A shift lever assembly malfunction.	• Replace the shift lever. • Contact your distributor.	Page 74

### 8B-2-5 Pedal Assembly

Symptom	Cause	Action	Reference
• The accelerator or brake does not function.	• The volume has not been initialized.	• Perform initialization.	Page 33
	• A connector is disconnected.	• Insert the connector securely.	Page 86
	• A pedal assembly malfunction.	• Replace the pedal assembly. • Contact your distributor.	Page 86

### 8B-2-6 Keypad

Symptom	Cause	Action	Reference
• The keypad does not function.	• A connector is disconnected.	• Replace the connector.	Page 75
	• A keypad malfunction.	• Replace the keypad. • Contact your distributor.	Page 75



— Must be performed by a technician —

## 8B-3 Error Displays (For Technicians)

### 8B-3-1 Coin Errors

Symptom	Cause	Action	Reference
• COIN ERROR 1 is displayed on the screen.	• A coin selector malfunction.	• Contact your distributor.	—————
	• A NA-JV PC board malfunction.	• Replace the NA-JV PC board.	Page 82
• COIN ERROR 2 is displayed on the screen.	• A service button malfunction.	• Contact your distributor.	—————
	• A NA-JV PC board malfunction.	• Replace the NA-JV PC board.	Page 82

### 8B-3-2 Steering Assembly Errors

Symptom	Cause	Action	Reference
• Overrun error E10, Framing error E11, Parity error E12, RAM error E13, Volume error A E14 or Over current error E15 is displayed on the screen.	• A steering assembly malfunction.	• Replace the steering assembly.	Page 72
• Volume error B E16 is displayed on the screen.	• A connector is disconnected.	• Insert the connector securely.	Page 79
	• A steering assembly malfunction.	• Replace the steering assembly.	Page 81
• Over speed error E17, Motor current error E18, Current Sensor error E19 or Power ON error E20 is displayed on the screen.	• A steering assembly malfunction.	• Replace the steering assembly.	Page 72
• Link error E21 is displayed on the screen.	• A connector is disconnected.	• Insert the connector securely.	Page 79

\* If Link error E21 occurs, I/O PCB ERROR E30 may also occur at the same time. Perform the checks in "8B-3-3 I/O Board Errors."

— Must be performed by a technician —

### 8B-3-3 I/O Board Errors

Symptom	Cause	Action	Reference
<ul style="list-style-type: none"> <li>I/O PCB ERROR E30 is displayed on the screen.</li> </ul>	<ul style="list-style-type: none"> <li>A NA-JV PC board malfunction.</li> </ul>	<ul style="list-style-type: none"> <li>Replace the NA-JV PC board.</li> </ul>	Page 82

### 8B-3-4 Camera Errors

Symptom	Cause	Action	Reference
<ul style="list-style-type: none"> <li>CAMERA ERROR E50 is displayed on the screen.</li> </ul>	<ul style="list-style-type: none"> <li>The connector of the USB camera cable is disconnected.</li> </ul>	<ul style="list-style-type: none"> <li>Insert the connector of the USB</li> </ul>	Page 77
	<ul style="list-style-type: none"> <li>An USB camera malfunction.</li> </ul>	<ul style="list-style-type: none"> <li>Replace the USB camera.</li> </ul>	Page 77

### 8B-3-5 Dongle Errors

Symptom	Cause	Action	Reference
<ul style="list-style-type: none"> <li>DONGLE ERROR E40 is displayed on the screen.</li> </ul>	<ul style="list-style-type: none"> <li>The USB dongle has not been inserted.</li> </ul>	<ul style="list-style-type: none"> <li>Turn off the power, insert the USB dongle that is inside SYS ES1 (B), and then turn on the power again.</li> </ul>	

— Must be performed by a technician —

## 8B-4 Removing and Installing Assemblies and Parts

### 8B-4-1 Front Assembly

#### (1) Replacing the Fluorescent Lamp

#### ⚠ WARNING

- To avoid electric shock, accidents or injuries to yourself or other people, or damage to the electronic circuits, be sure to turn off the power switch before starting work.

#### ⚠ CAUTION

- The fluorescent lamp becomes hot. Be very careful when removing it.
- The fluorescent lamp is replaced while standing in a high location. Be very careful while working.

- 1** Remove the two torx bolts (M5 x 16) from the front of the front assembly, and then remove the top cover.
- 2** Replace the fluorescent lamp (30 W).

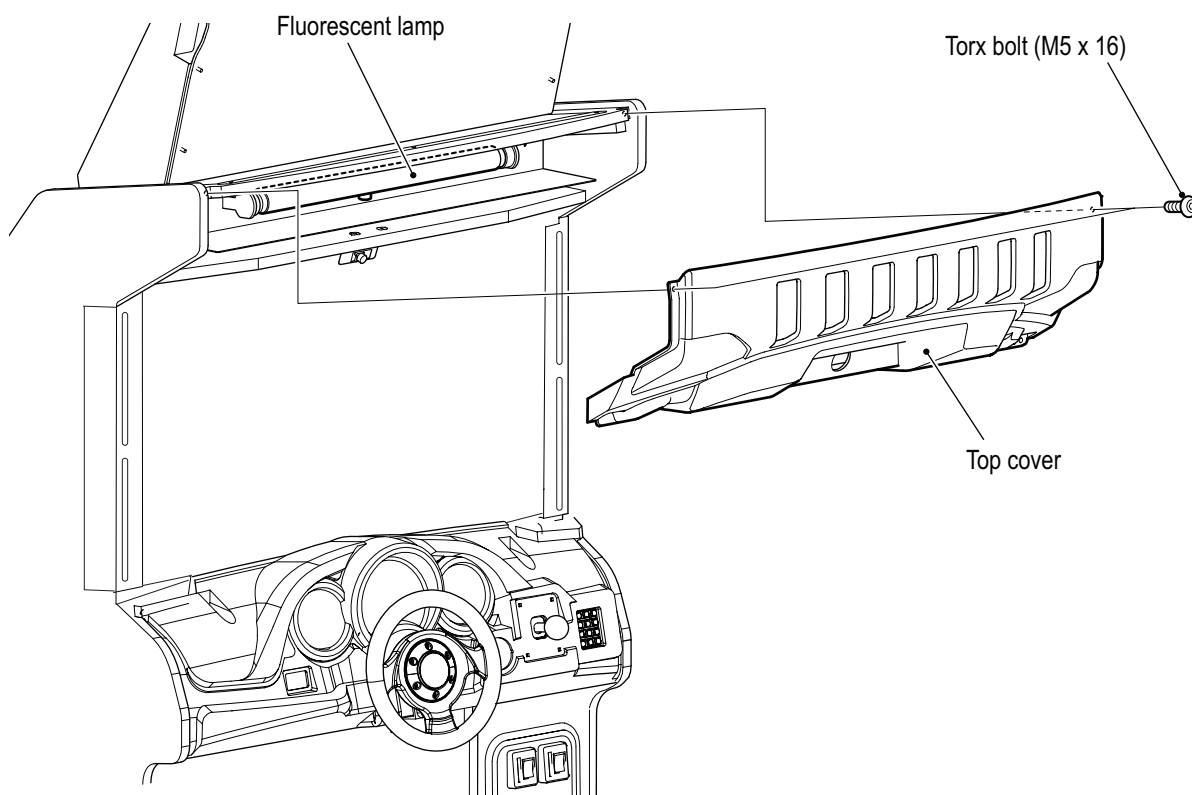

- 3** To install, perform the procedure in reverse.

— Must be performed by a technician —

(2) Removing and Installing the Control Cover

**! WARNING**

- To avoid electric shock, accidents or injuries to yourself or other people, or damage to the electronic circuits, be sure to turn off the power switch before starting work.

- 1 Remove the two torx bolts (M5 x 16) and the four torx bolts (M4 x 15) from the front of the front assembly, and the four torx bolts (M5 x 16) from under the control cover.

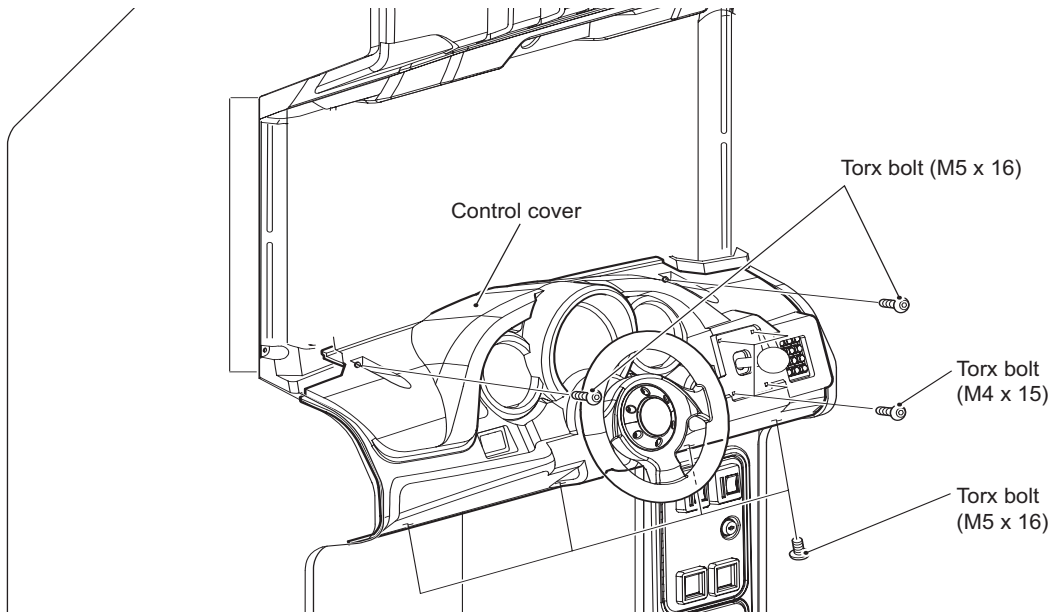

- 2 While lifting up the control cover, remove it towards you. On the rear, disconnect and remove the two connectors of the view selector and NITROUS switch.

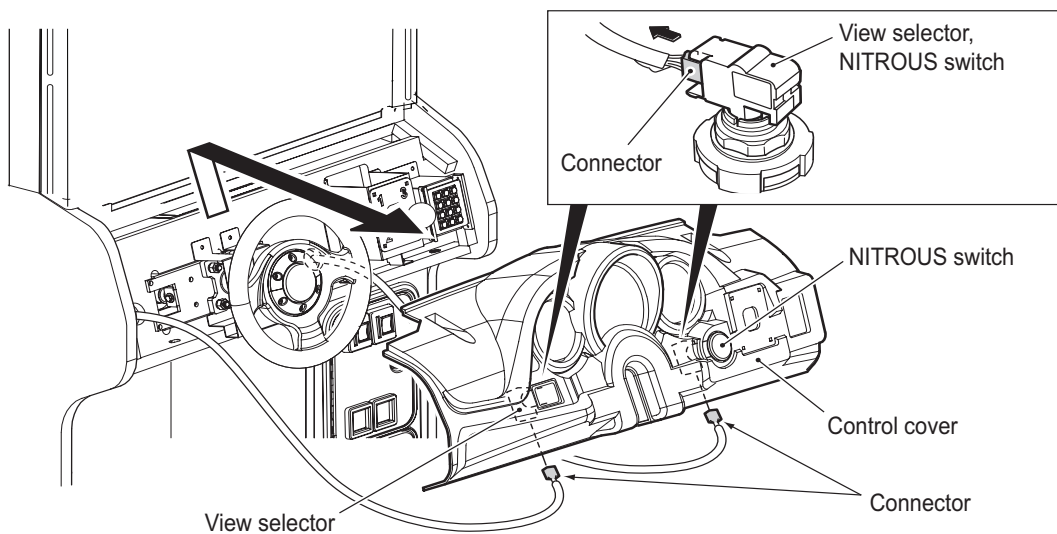

- 3 To install, perform the procedure in reverse.

**NOTICE**

- When installing the control cover, be careful not to trap the harness.

— Must be performed by a technician —

### (3) Replacing the View Selector, NITROUS Switch and Lamps

The view selector is used as an example in the following procedure. Use the same procedure to replace the NITROUS switch.

#### ⚠ WARNING

- To avoid electric shock, accidents or injuries to yourself or other people, or damage to the electronic circuits, be sure to turn off the power switch before starting work.

- 1** Remove the control cover. (See “8B-4-1 (2) Removing and Installing the Control Cover” on page 66.)
- 2** Turn the illuminated switch to the left to unlock it, and then remove it.

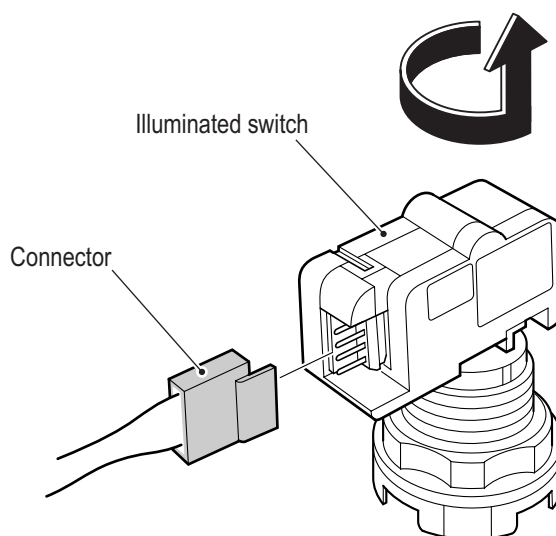

- 3** Pull out the lamp.

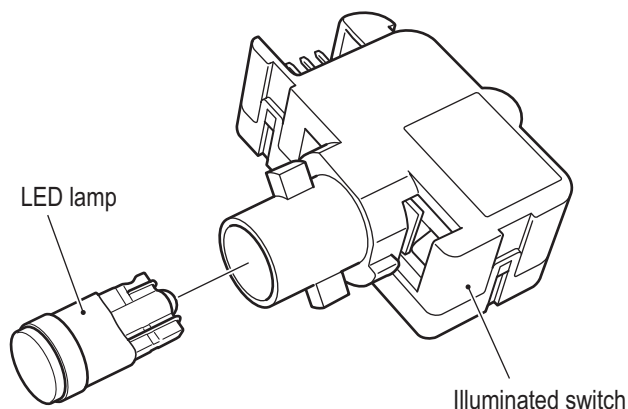

- 4** Replace the view selector and the lamp.
- 5** To install, perform the procedure in reverse.  
Use the same procedure to replace the NITROUS switch.

\* The LED lamp has positive and negative polarity. Take care to position the lamp correctly during replacement.



- After completing the replacement, be sure to check the operation. (See “7-5-4 (c) SWITCH TEST” on page 35.)

— Must be performed by a technician —

(4) Replacing the LCD Monitor

**! WARNING**

- To avoid electric shock, accidents or injuries to yourself or other people, or damage to the electronic circuits, be sure to turn off the power switch before starting work.

**! CAUTION**

- The LCD monitor weighs approx. 22 lb. Be very careful while working, because dropping it may cause injury.

- 1** Remove the two torx bolts (M5 X30) from the rear of the front assembly, and then unlock the rear door with the service key and then remove it.

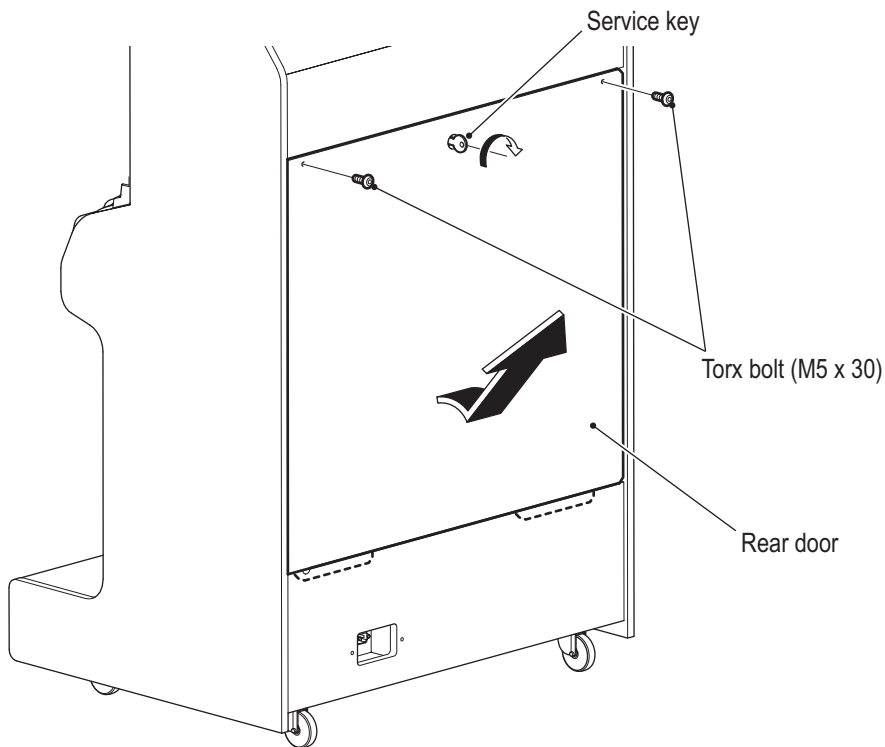

- 2** Remove the two connectors of the LCD monitor.

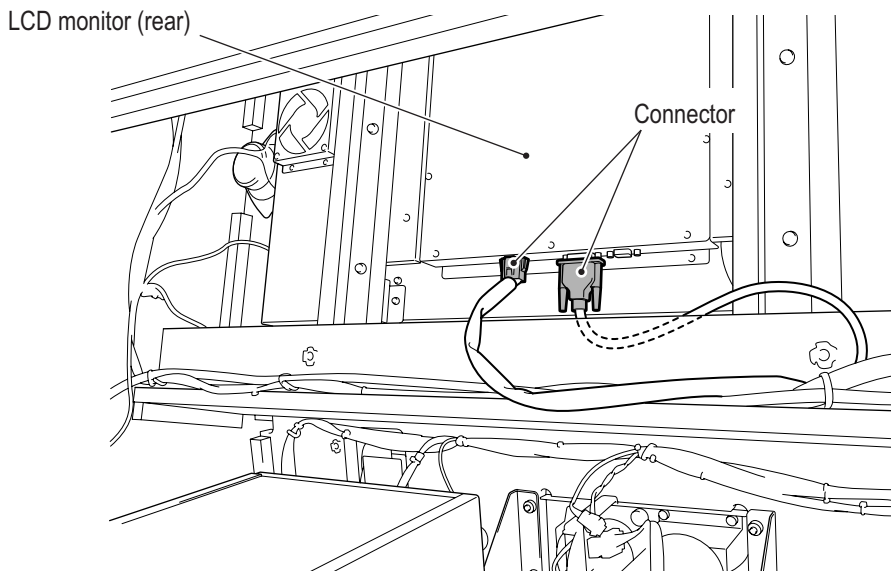

— Must be performed by a technician —

- 3** Remove the control cover. (See “8B-4-1 (2) Removing and Installing the Control Cover” on page 66.)
- 4** Remove the two torx bolts (M5 x 16) from the front of the front assembly, and then remove the top cover.
- 5** Remove the four kep nuts, and then remove the monitor side cover (L).  
Remove the monitor side cover (R) in the same way.

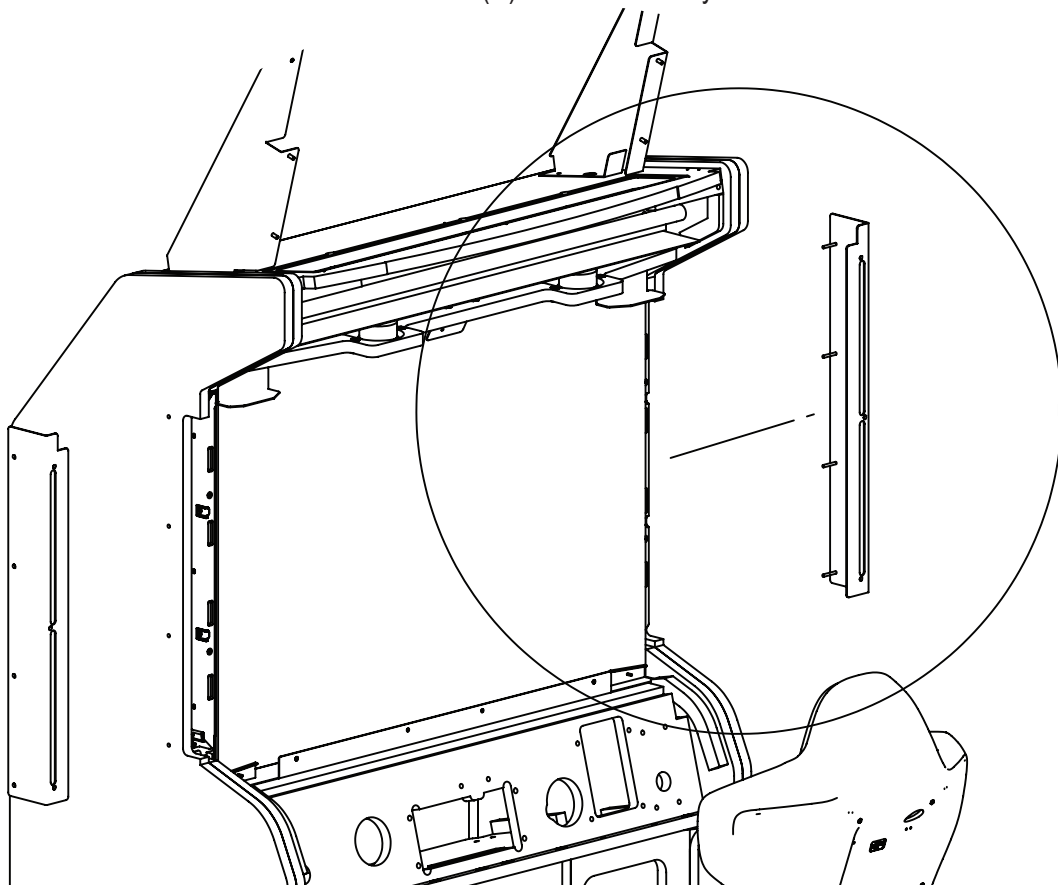

- 6** Remove the three torx bolts (M5 x 16), and then remove the monitor stopper (lower).

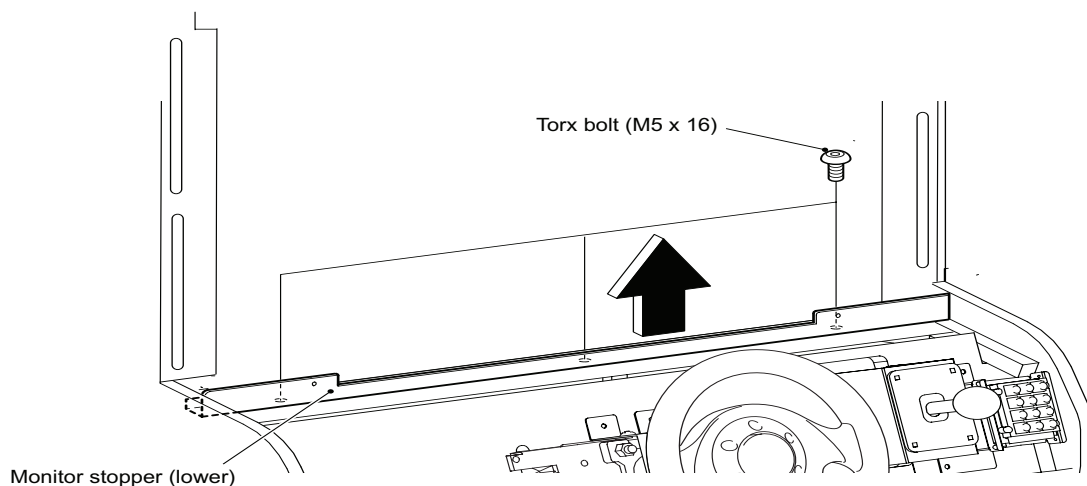

— Must be performed by a technician —

---

- 7** Loosen the two torx bolts (M5 x 16) on the rear of the camera assembly, and then remove the monitor stopper (upper).

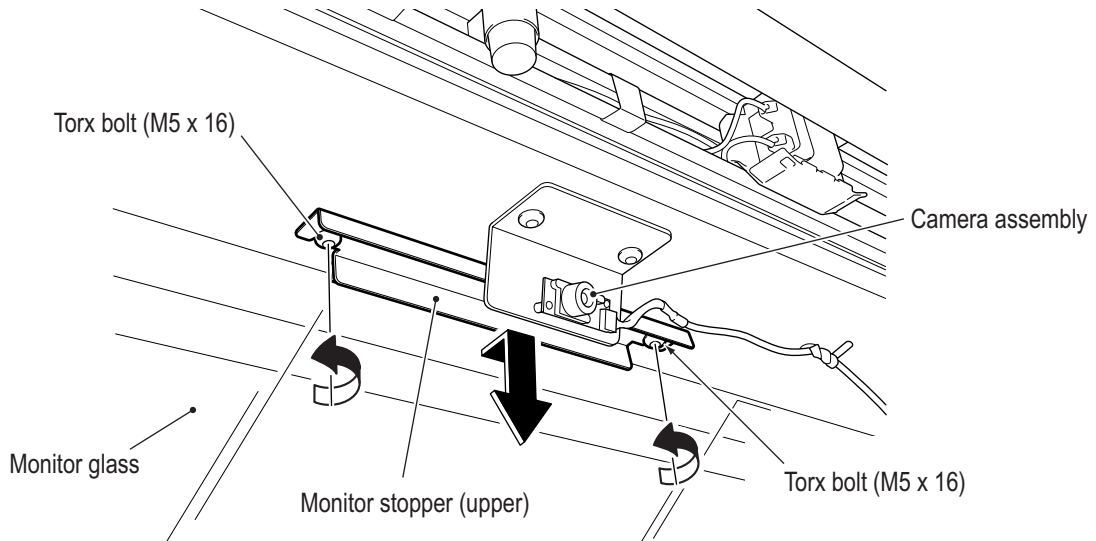

- 8** Lift up the monitor glass slightly, pull out the bottom side towards you and remove it.

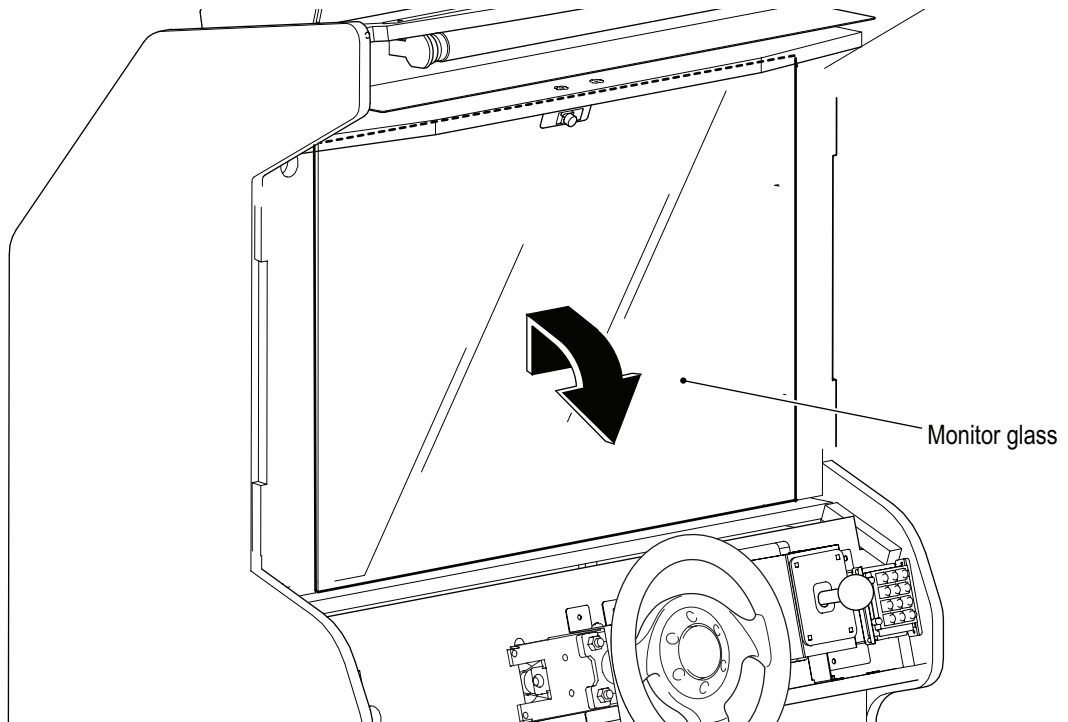



— Must be performed by a technician —

- 9** Remove the four flange socket bolts (M5 x 25), and then remove the LCD monitor.

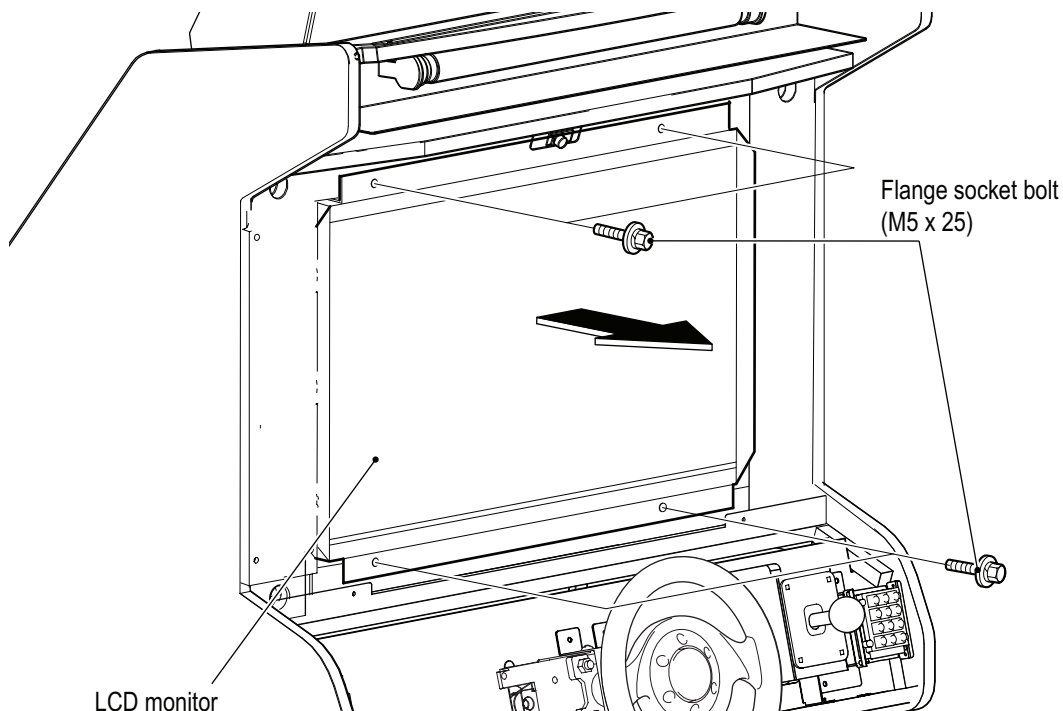

- 10** Remove the four Phillips pan head screws (M4 x 10), remove the LCD brackets and replace the LCD monitor.

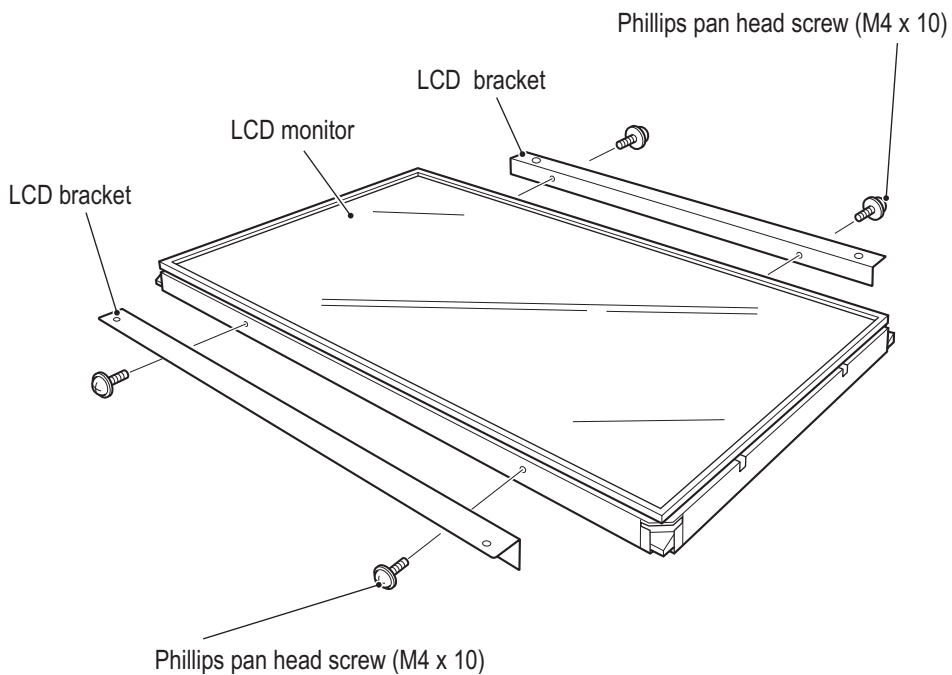

- 11** To install, perform the procedure in reverse.

— Must be performed by a technician —

(5) Replacing the Steering Assembly

**! WARNING**

- To avoid electric shock, accidents or injuries to yourself or other people, or damage to the electronic circuits, be sure to turn off the power switch before starting work.

**! CAUTION**

- The steering assembly weighs approx. 26.5 lb. Be very careful while working, because dropping it may cause injury.

- 1** Remove the rear door. (See **1** in “8B-4-1 (4) Replacing the LCD Monitor” on page 68.)
- 2** Remove the two connectors of the steering assembly.

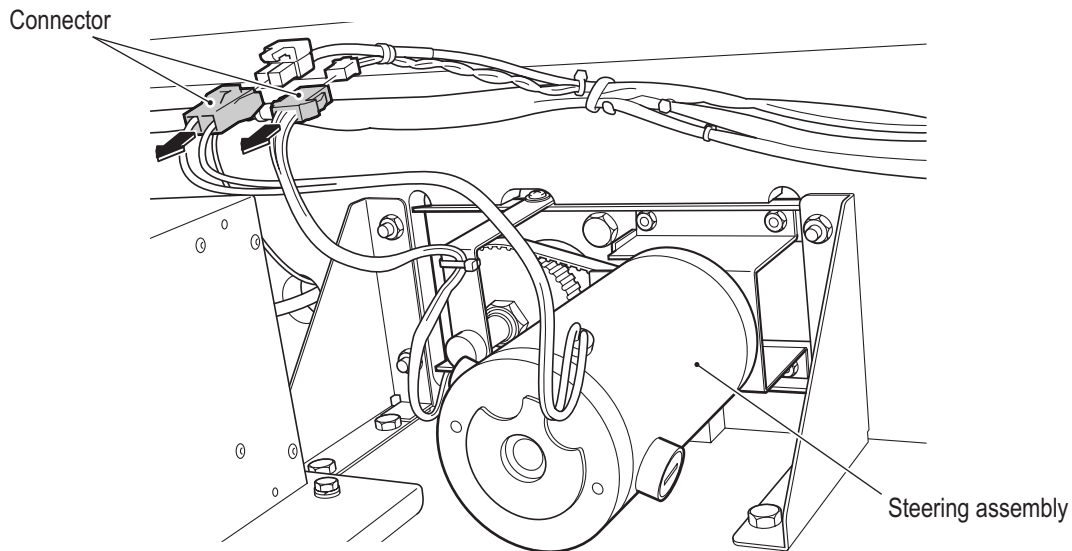

- 3** Remove the control cover. (See “8B-4-1 (2) Removing and Installing the Control Cover” on page 66.)
- 4** Remove the two button bolts (M5 x 16), and then remove the control panel under cover.

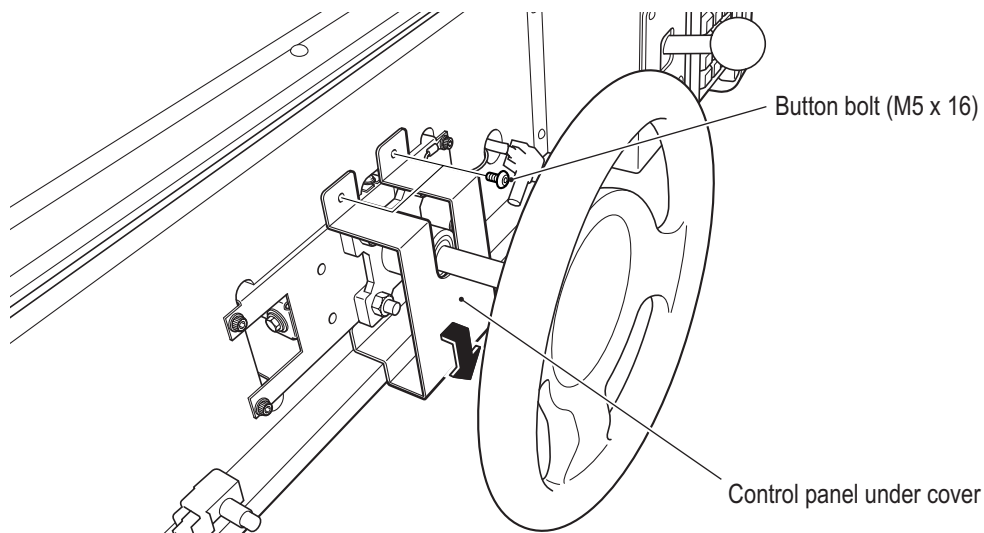

— Must be performed by a technician —

- 5** Remove the four flange sockets (M8 x 30) and the ground terminal, then slowly pull out the steering assembly and replace it.

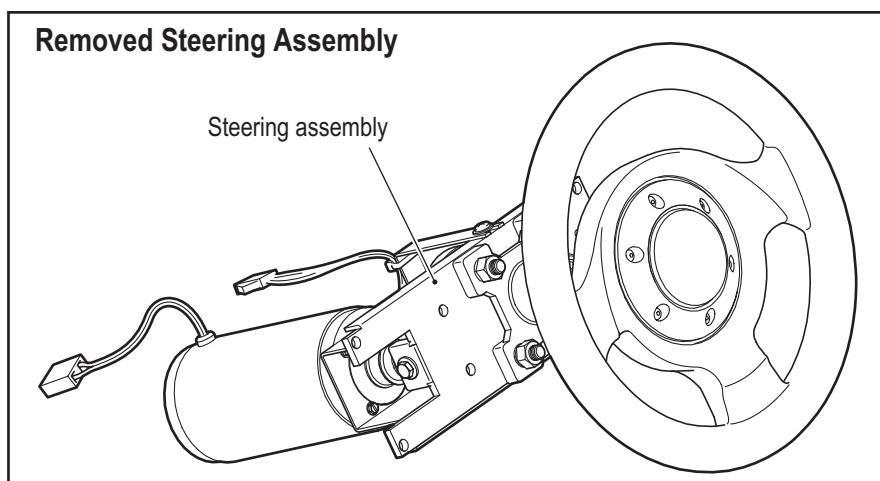
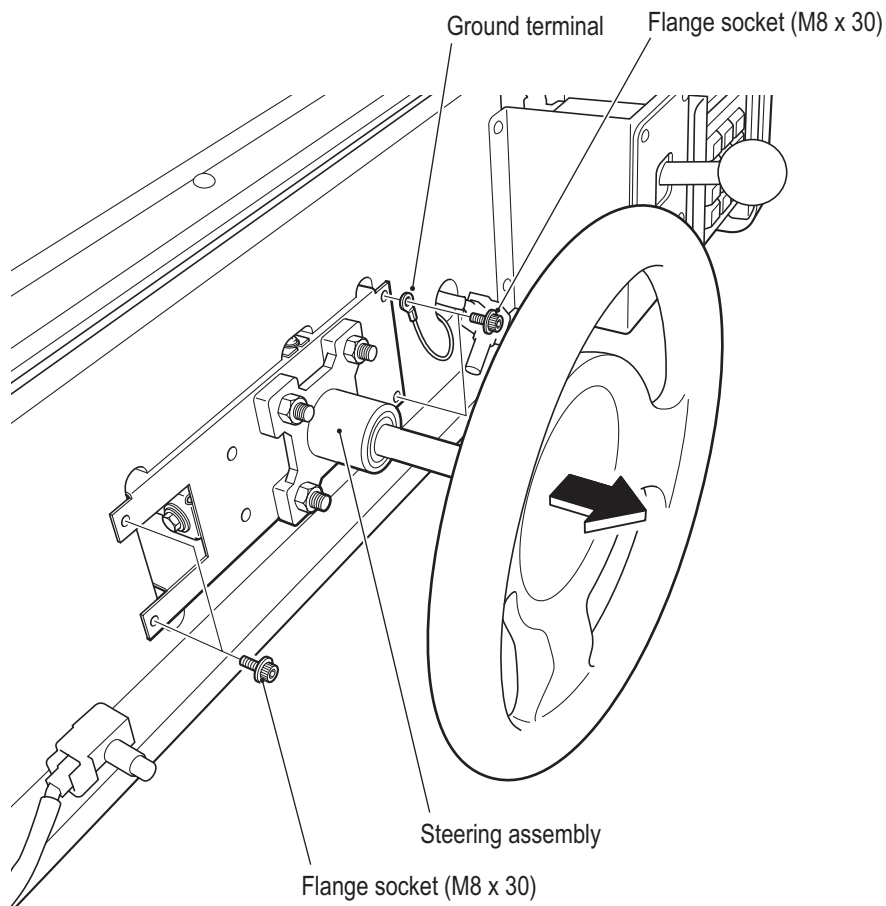

- 6** To install, perform the procedure in reverse.



- After completing the replacement, be sure to initialize and check the operation. (See “7-5-4 (b) I/F INITIALIZE (STEERING & GAS)” on page 33 and “7-5-4 (c) SWITCH TEST” on page 35.)

— Must be performed by a technician —

(6) Replacing the Shift Assembly

**⚠ WARNING**

- To avoid electric shock, accidents or injuries to yourself or other people, or damage to the electronic circuits, be sure to turn off the power switch before starting work.

- 1 Remove the rear door. (See **1** in “8B-4-1 (4) Replacing the LCD Monitor” on page 68.)
- 2 Disconnect the connector of the shift assembly.

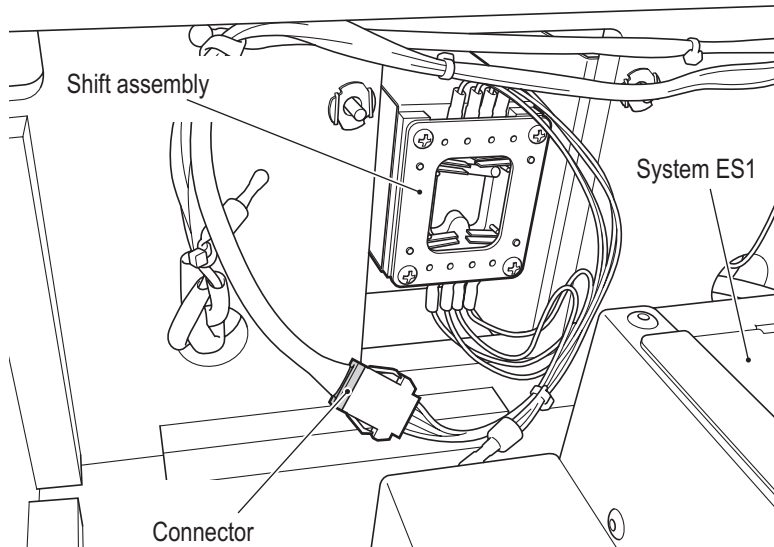

- 3 Remove the control cover. (See “8B-4-1 (2) Removing and Installing the Control Cover” on page 66.)
- 4 Remove the shift assembly and replace it.

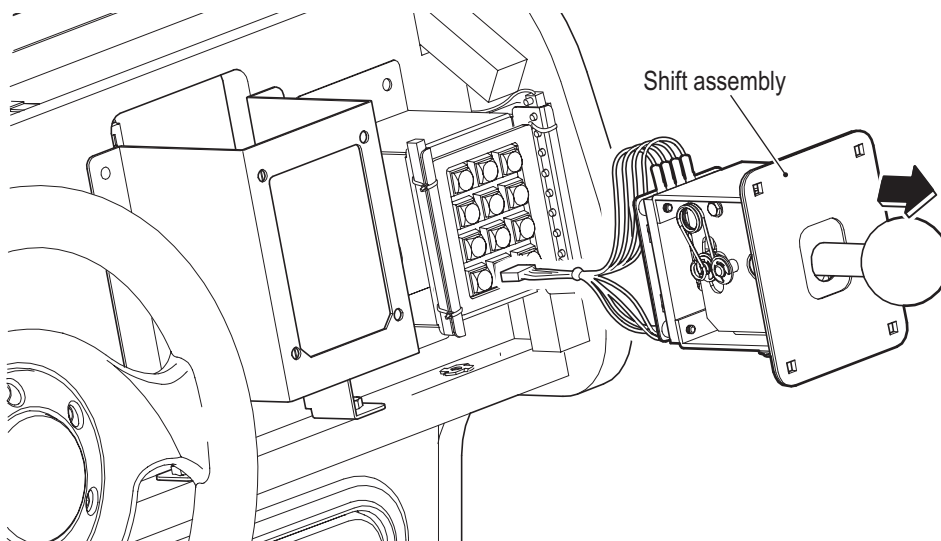

- 5 To install, perform the procedure in reverse.



- After completing the replacement, be sure to check the operation. (See “7-5-4 (c) SWITCH TEST” on page 35.)

— Must be performed by a technician —

### (7) Replacing the Keypad

#### **⚠ WARNING**

- To avoid electric shock, accidents or injuries to yourself or other people, or damage to the electronic circuits, be sure to turn off the power switch before starting work.

- 1** Remove the control cover. (See “8B-4-1 (2) Removing and Installing the Control Cover” on page 66.)
- 2** Remove the four Phillips pan head screws (M4 x 16), then remove the keypad panel bracket and the keypad panel.

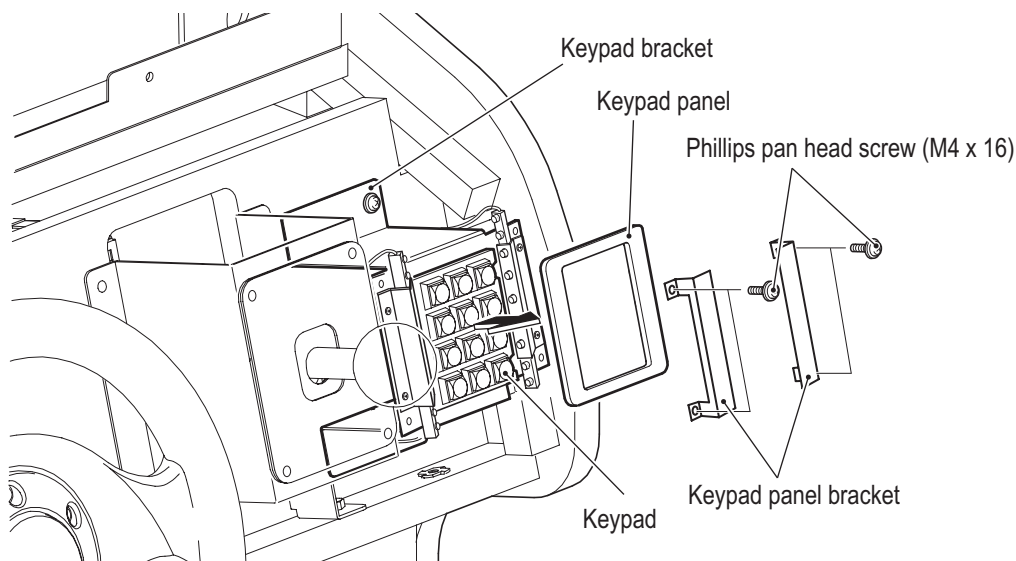

- 3** Remove the two cap screws (M5 x 16), and then remove the keypad bracket.
- 4** Disconnect the connector, remove the four Phillips pan head screws (with flat and spring washers) (M4 x 16), then remove the keypad and replace it.

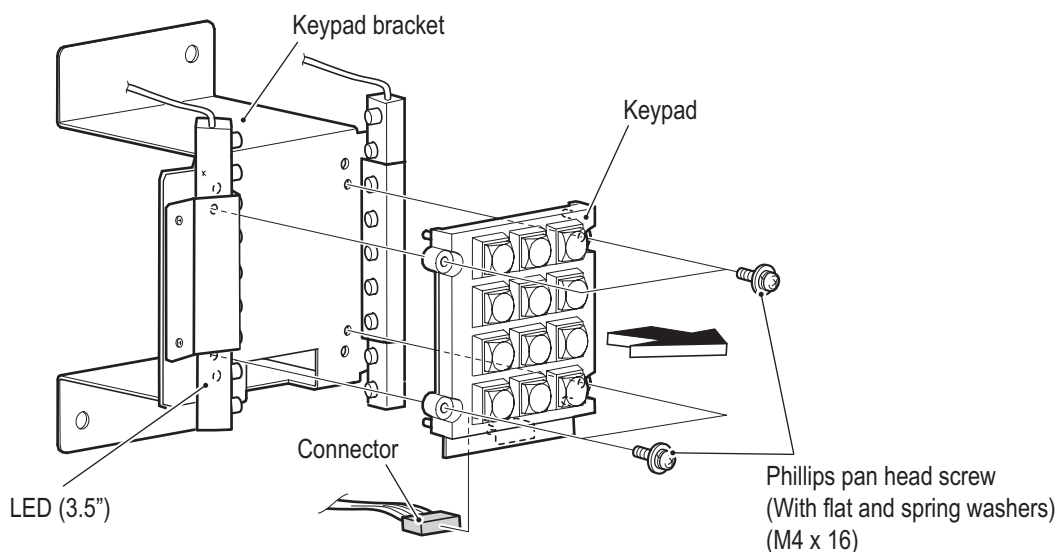

- 5** To install, perform the procedure in reverse.



- After completing the replacement, be sure to check the operation. (See “7-5-4 (c) SWITCH TEST” on page 35.)

— Must be performed by a technician —

(8) Replacing the LEDs (3.5")

**⚠ WARNING**

- To avoid electric shock, accidents or injuries to yourself or other people, or damage to the electronic circuits, be sure to turn off the power switch before starting work.

- 1** Remove the keypad bracket. (See "8B-4-1 (7) Replacing the Keypad" on page 75.)
- 2** Disconnect the connector, then remove the four Phillips pan head screws (M4 x 16) and the two LED brackets.  
There are two LEDs (3.5"). Use the same procedure to replace the other one.

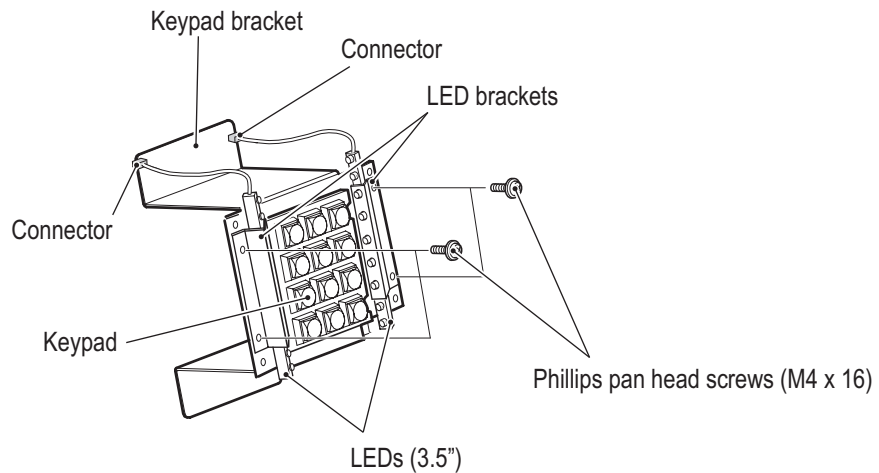

- 3** To install, perform the procedure in reverse.  
When installing, cut the excess length of the bands.



- After completing the replacement, be sure to check the operation.  
(See "7-5-4 (d) LAMP TEST" on page 37.)

— Must be performed by a technician —

### (9) Replacing the Camera

#### ⚠ WARNING

- To avoid electric shock, accidents or injuries to yourself or other people, or damage to the electronic circuits, be sure to turn off the power switch before starting work.

- 1** Remove the top cover, monitor side cover (L) and monitor side cover (R). (See **4** and **5** in “8B-4-1 (4) Replacing the LCD Monitor” on page 69.)
- 2** Disconnect the connector, remove the two Phillips pan head screws (with flat and spring washers) (M2 x 6), and remove the camera assembly.

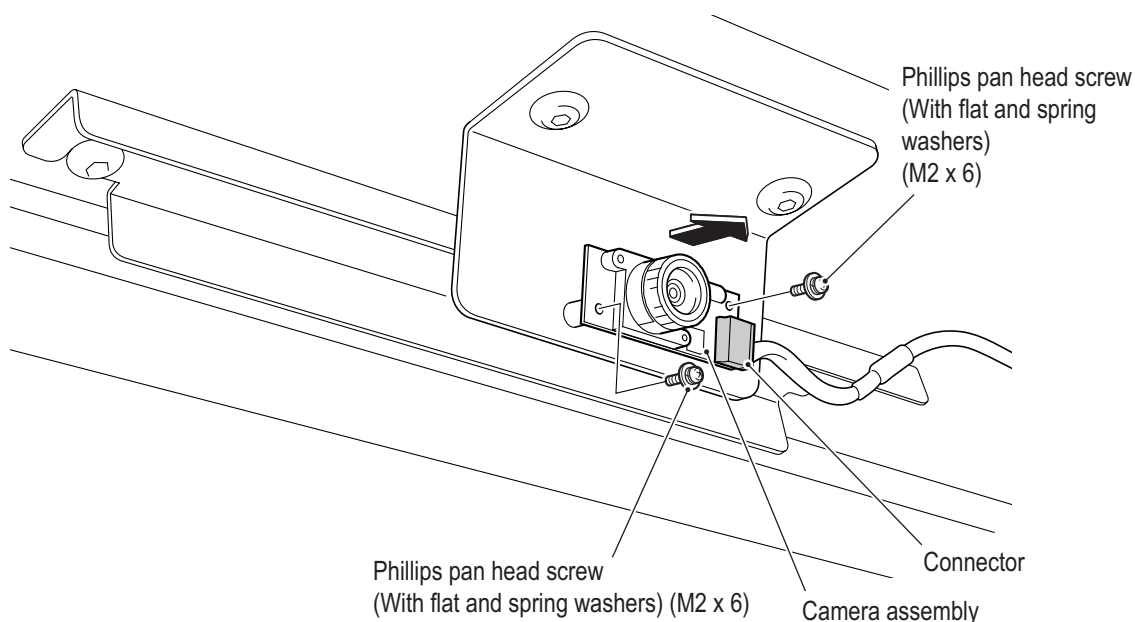

- 3** To install, perform the procedure in reverse.



- After completing the replacement, be sure to check the operation. (See “7-5-4 (a) CAMERA SETTING” on page 31.)

— Must be performed by a technician —

---

(10) Replacing the LEDs

There are six LEDs. The replacement of the top left LED is described below.

**! WARNING**

- To avoid electric shock, accidents or injuries to yourself or other people, or damage to the electronic circuits, be sure to turn off the power switch before starting work.

- 1** Remove the monitor side cover (L).  
(See **5** in “8B-4-1 (4) Replacing the LCD Monitor” on page 69.)
- 2** Disconnect the connectors.
- 3** Remove the ty-wraps securing the LED strip to the bracket and replace the defective LED strip.

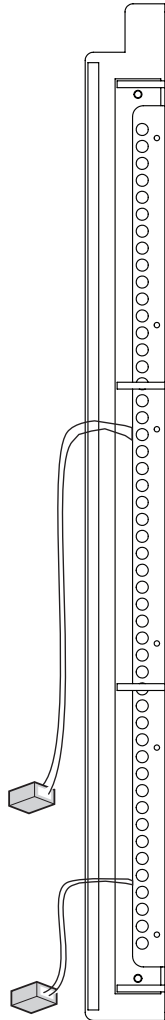

- 4** To install, perform the procedure in reverse adding new ty-wraps.



- After completing the replacement, be sure to check the operation.  
(See “7-5-4 (d) LAMP TEST” on page 37.)



— Must be performed by a technician —

## 8B-4-2 Front Assembly Rear Side

### (1) Replacing the SYS ES1 (B) Assembly

#### **⚠ WARNING**

- To avoid electric shock, accidents or injuries to yourself or other people, or damage to the electronic circuits, be sure to turn off the power switch before starting work.

#### **⚠ CAUTION**

- The SYS ES1 (B) assembly weighs approx. 17.6 lb. Be very careful while working, because dropping it may cause injury.

- 1** Remove the rear door. (See **1** in "8B-4-1 (4) Replacing the LCD Monitor" on page 68.)
- 2** Disconnect the seven connectors, remove the four flange socket bolts (with flat and spring washers) (M6 x 12), and remove the game PC board together with the rack base.

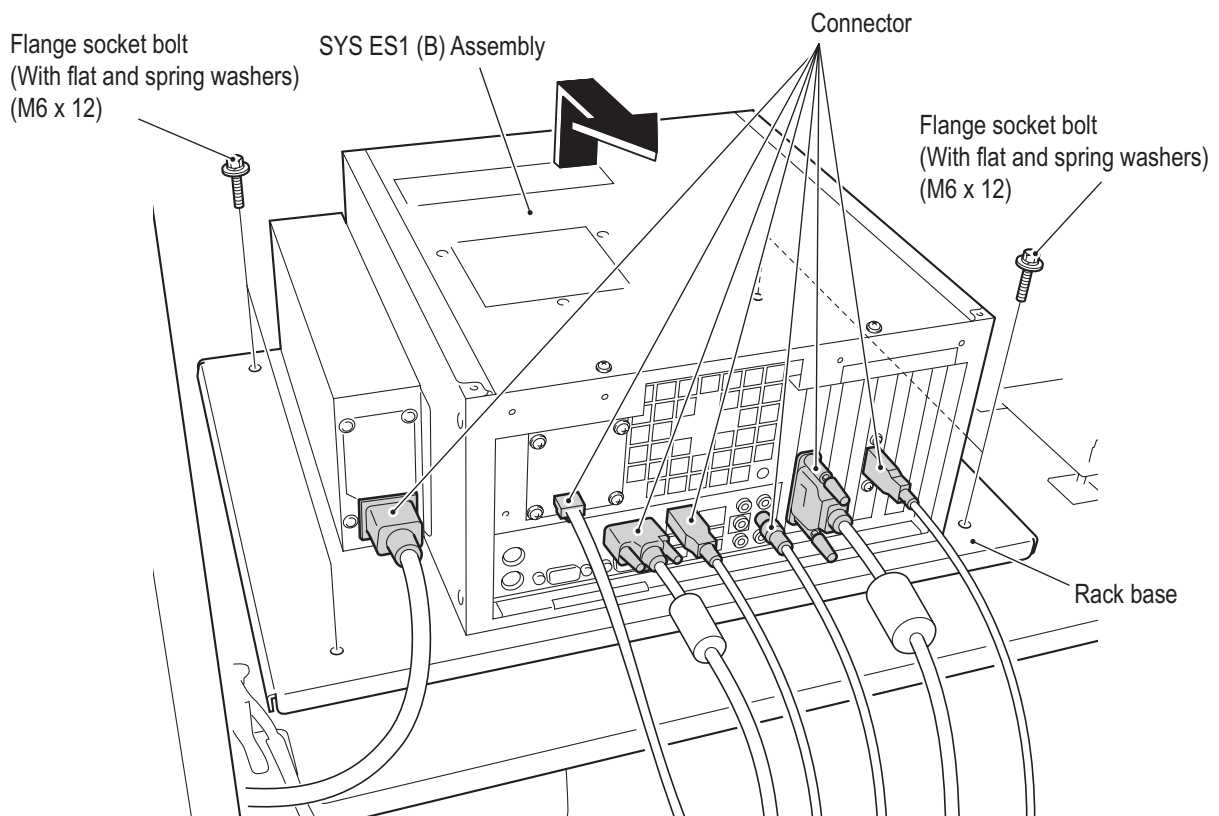

— Must be performed by a technician —

---

- 3** Turn over the game PC board. Remove the six Phillips pan head screws (with flat and spring washers) (M4 x 14), remove the rack base and replace the game PC board.

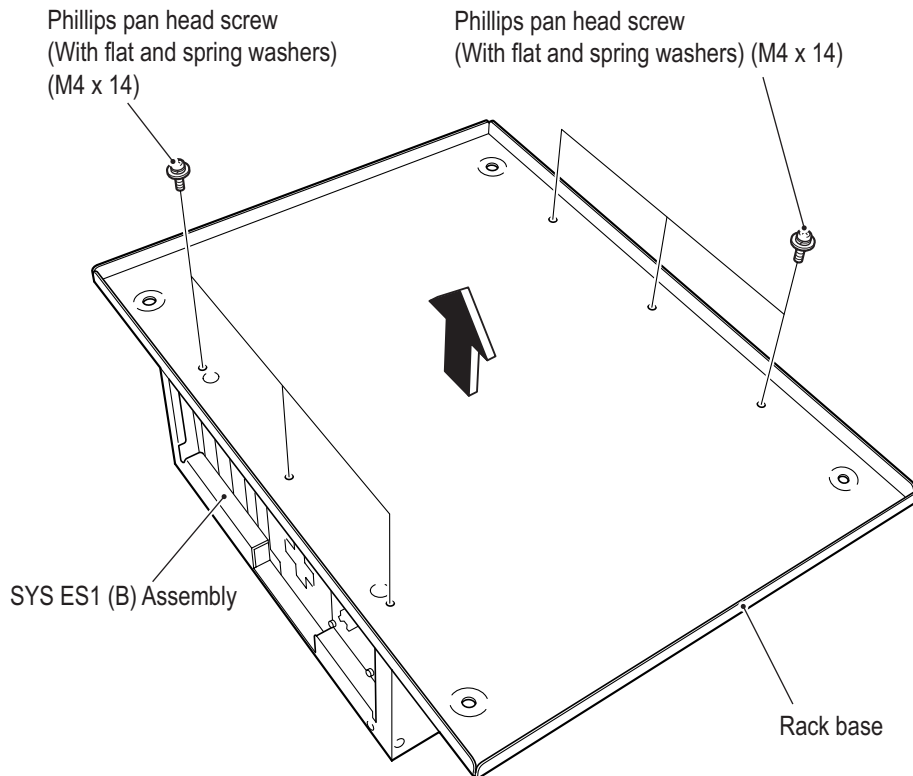

- 4** To install, perform the procedure in reverse.



- When sending a part for repair (game PC board), wrap it in sponge or bubble wrap before packing it in a cardboard box. Make sure that the box is not exposed to outside pressure.
- After completing the replacement, be sure to check the operation and initialize. (See “7-5 Test Mode” on page 26.)

— Must be performed by a technician —

## (2) Replacing the Steering PC Board

### ⚠ WARNING

- To avoid electric shock, accidents or injuries to yourself or other people, or damage to the electronic circuits, be sure to turn off the power switch before starting work.

### NOTICE

- To avoid damaging the electronic circuits, make sure that the connector direction is correct when connecting the connectors.
- The PC board is sensitive to static electricity. If a person handles a PC board while charged with static electricity, the parts on the PC board may be damaged. Before handling the PC board, discharge the static electricity from your body; for example, by touching the surface of grounded metal.

- 1** Remove the rear door. (See **1** in “8B-4-1 (4) Replacing the LCD Monitor” on page 68.)
- 2** Disconnect the six connectors, remove the four Phillips pan head screws (with flat and spring washers) (M3 x 6), and replace the steering PC board.

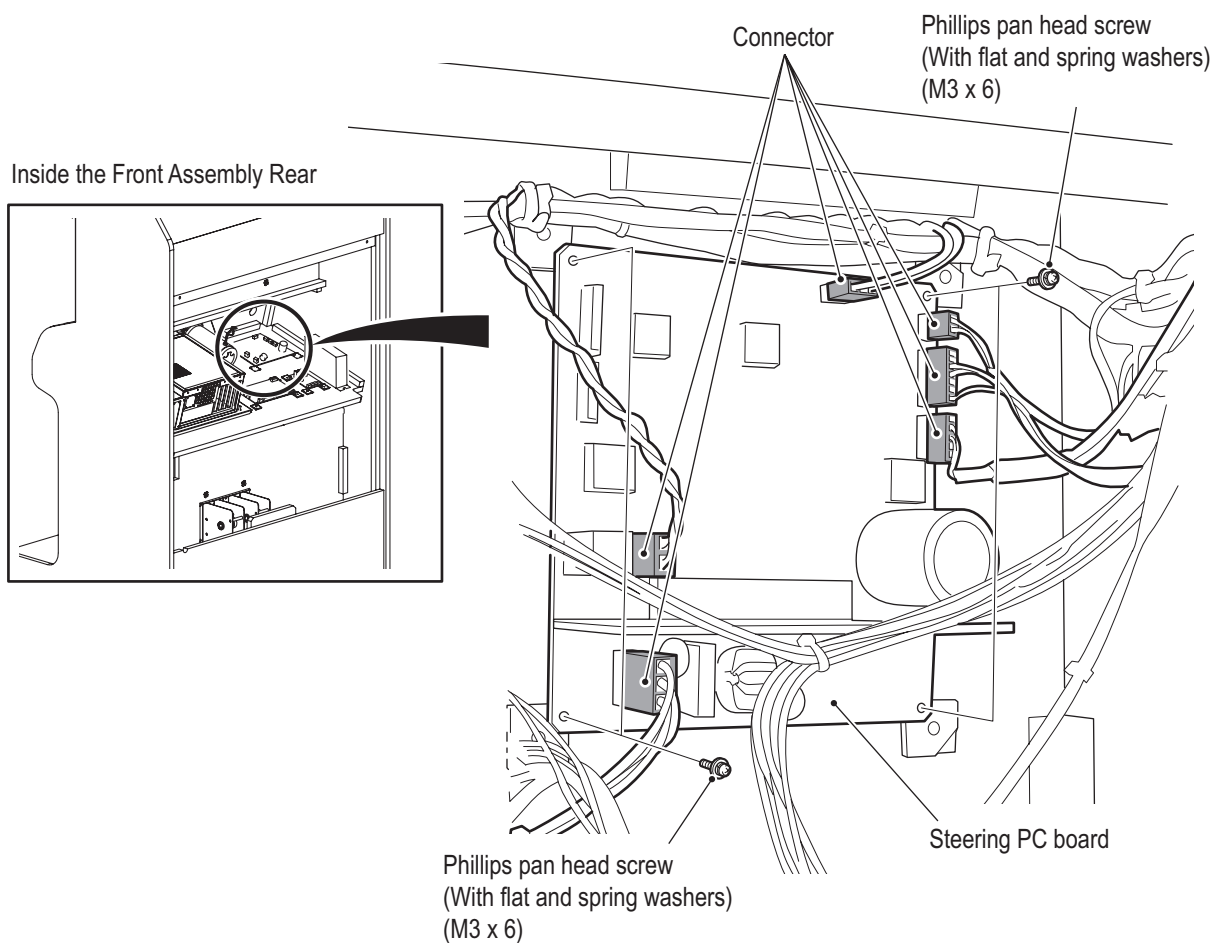

- 3** To install, perform the procedure in reverse.

### NOTICE

- After completing the replacement, be sure to check the operation and initialize. (See “7-5-4 (b) I/F INITIALIZE (STEERING & GAS)” on page 33 and “7-5-4 (c) SWITCH TEST” on page 35.)

— Must be performed by a technician —

(3) Replacing the NA-JV PC Board

**⚠ WARNING**

- To avoid electric shock, accidents or injuries to yourself or other people, or damage to the electronic circuits, be sure to turn off the power switch before starting work.

**NOTICE**

- To avoid damaging the electronic circuits, make sure that the connector direction is correct when connecting the connectors.
- The PC board is sensitive to static electricity. If a person handles a PC board while charged with static electricity, the parts on the PC board may be damaged. Before handling the PC board, discharge the static electricity from your body; for example, by touching the surface of grounded metal.

- 1** Remove the rear door. (See **1** in “8B-4-1 (4) Replacing the LCD Monitor” on page 68.)
- 2** Disconnect the four connectors, remove the four Phillips pan head screws (with flat and spring washers) (M3 x 6), and replace the NA-JV PC board.

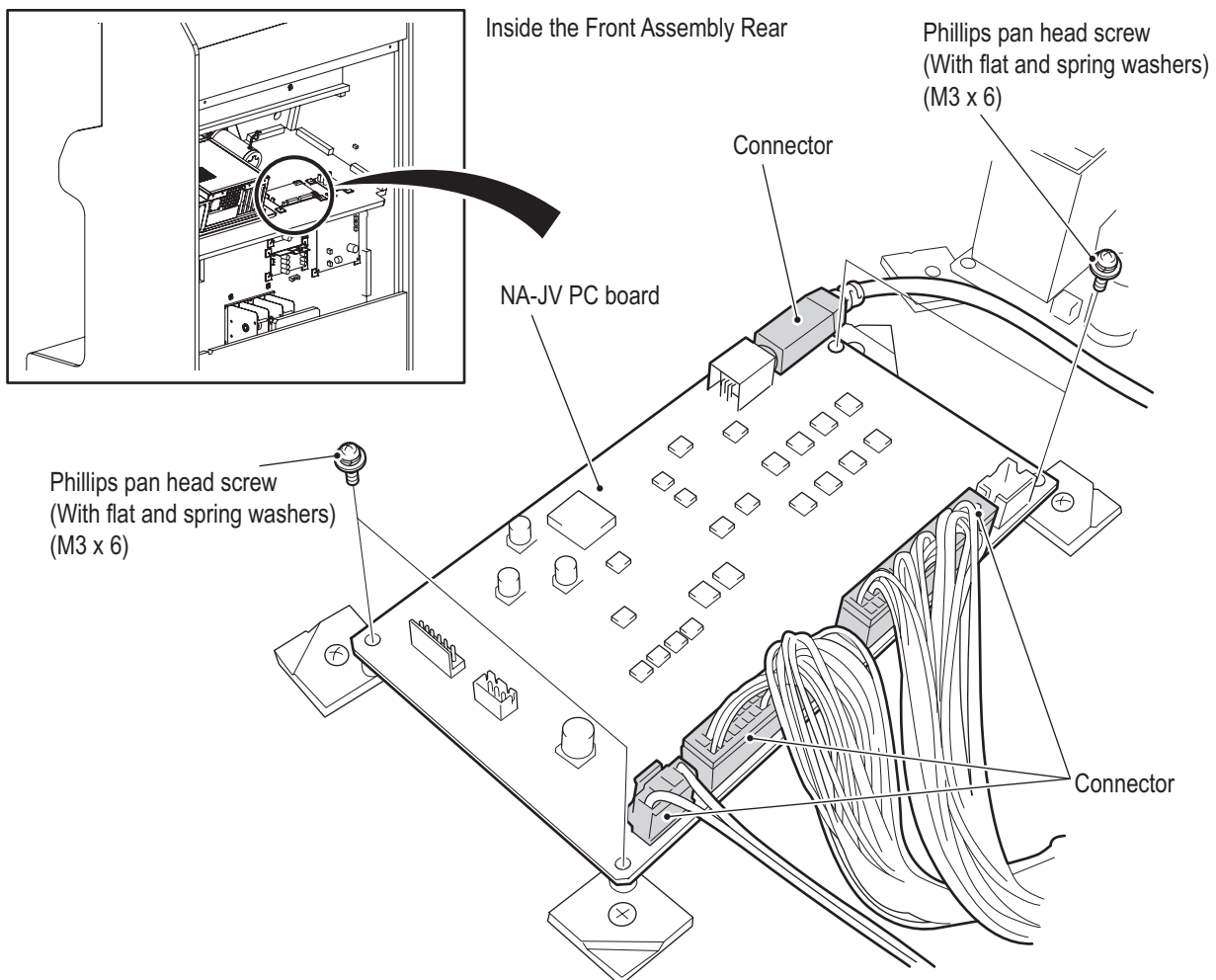

- 3** To install, perform the procedure in reverse.

— Must be performed by a technician —

#### (4) Replacing the Amp PC Board

### ⚠ WARNING

- To avoid electric shock, accidents or injuries to yourself or other people, or damage to the electronic circuits, be sure to turn off the power switch before starting work.

### NOTICE

- To avoid damaging the electronic circuits, make sure that the connector direction is correct when connecting the connectors.
- The PC board is sensitive to static electricity. If a person handles a PC board while charged with static electricity, the parts on the PC board may be damaged. Before handling the PC board, discharge the static electricity from your body; for example, by touching the surface of grounded metal.

- 1** Remove the rear door. (See **1** in “8B-4-1 (4) Replacing the LCD Monitor” on page 68.)
- 2** Disconnect the four connectors, remove the four Phillips pan head screws (with flat and spring washers) (M3 x 6), and replace the amp PC board.

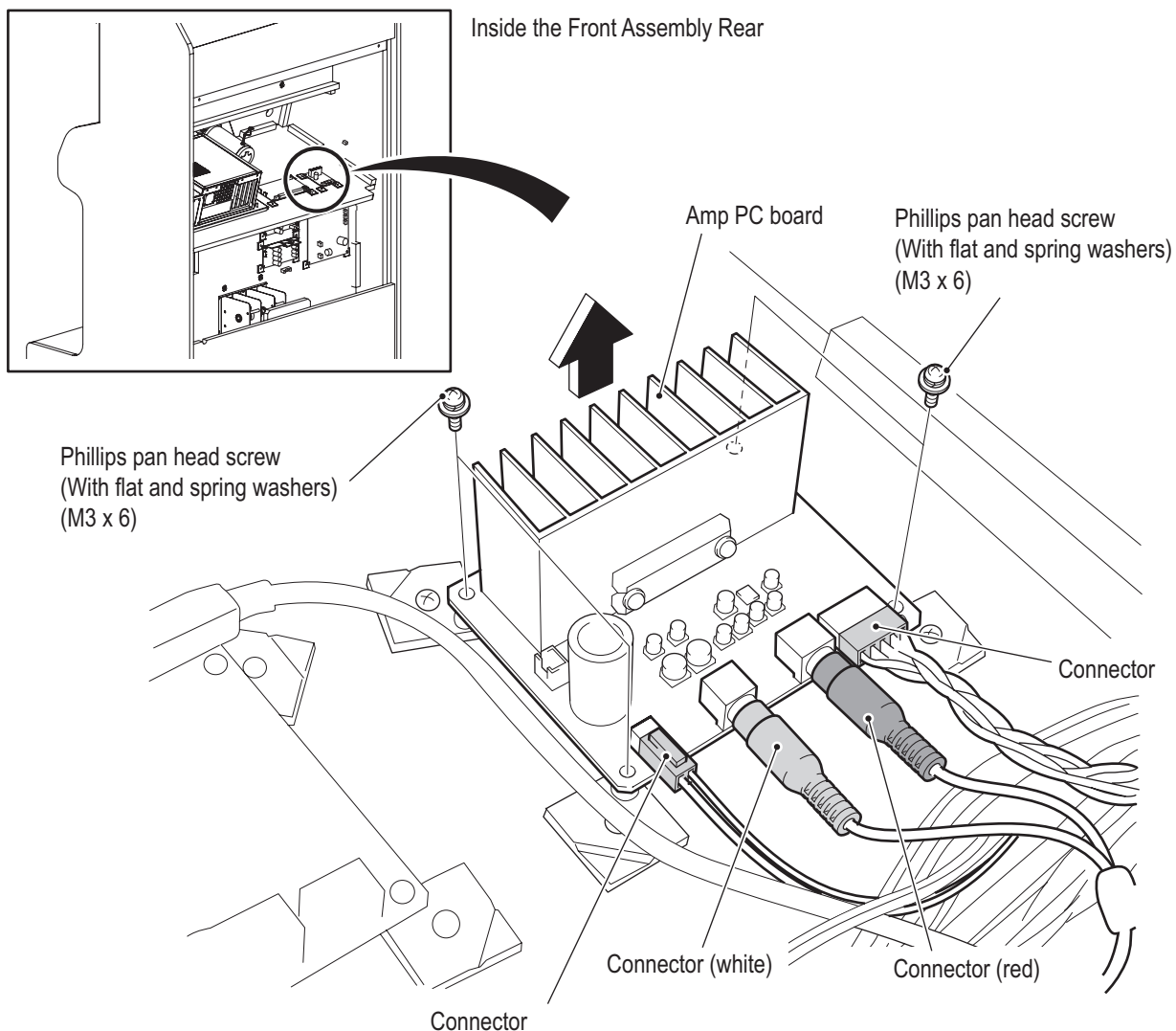

- 3** To install, perform the procedure in reverse.

— Must be performed by a technician —

(5) Replacing the Power Supply (12 V)

**⚠ WARNING**

- To avoid electric shock, accidents or injuries to yourself or other people, or damage to the electronic circuits, be sure to turn off the power switch before starting work.

**NOTICE**

- To avoid damaging the electronic circuits, make sure that the connector direction is correct when connecting the connectors.
- The PC board is vulnerable to static electricity. If a person handles a PC board while charged with static electricity, the parts on the PC board may be damaged. Before handling the PC board, discharge the static electricity from your body; for example, by touching the surface of grounded metal.

- 1** Remove the rear door. (See **1** in “8B-4-1 (4) Replacing the LCD Monitor” on page 68.)
- 2** Disconnect the two connectors, remove the two Phillips pan head screws (M4 x 12), and replace the power supply (12 V).

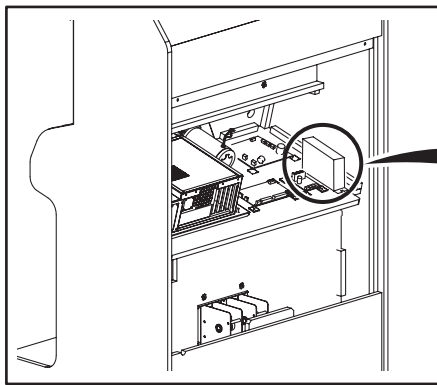

Inside the Front Assembly Rear

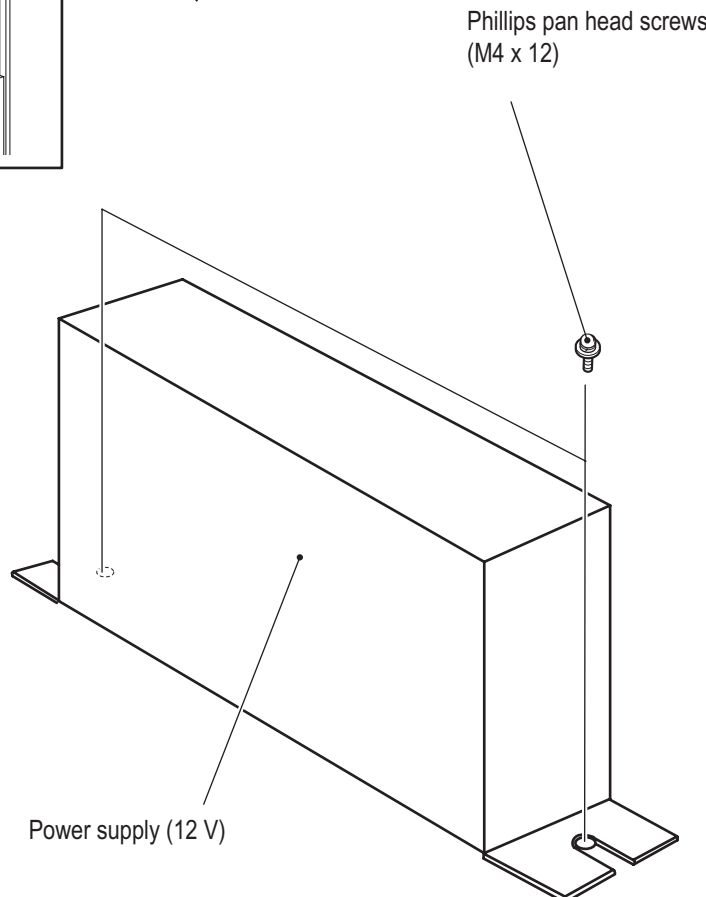

- 3** To install, perform the procedure in reverse.

— Must be performed by a technician —

### (6) Replacing the Fuse

#### WARNING

- To avoid electric shock, accidents or injuries to yourself or other people, or damage to the electronic circuits, be sure to turn off the power switch before starting work.
- Never use a fuse other than the specified fuse (250 V 5 A), because it may cause a fire. A fuse is required to prevent a fire or accident. To order a fuse, contact your distributor.

- 1** Remove the rear door. (See **1** in “8B-4-1 (4) Replacing the LCD Monitor” on page 68.)
- 2** Replace the fuse (5 A).

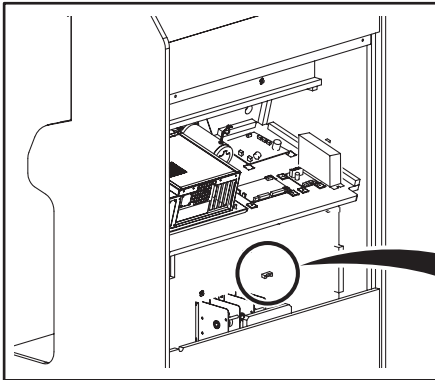

Inside the Front Assembly Rear

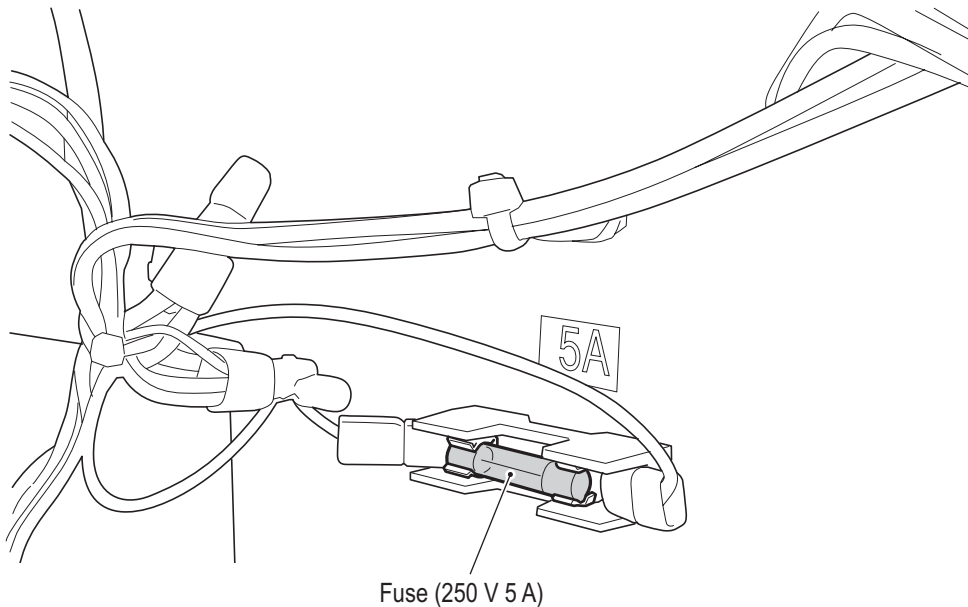

- 3** To install, perform the procedure in reverse.

— Must be performed by a technician —

## 8B-4-3 Pedal Assembly

### (1) Removing and Installing the Pedal Assembly

#### ⚠ WARNING

- To avoid electric shock, accidents or injuries to yourself or other people, or damage to the electronic circuits, be sure to turn off the power switch before starting work.

#### ⚠ CAUTION

- The pedal assembly weighs approx. 8.8 lb. Be very careful while working, because dropping it may cause an injury.

**1** Remove the rear door. (See **1** in “8B-4-1 (4) Replacing the LCD Monitor” on page 68.)

**2** Disconnect the connector.

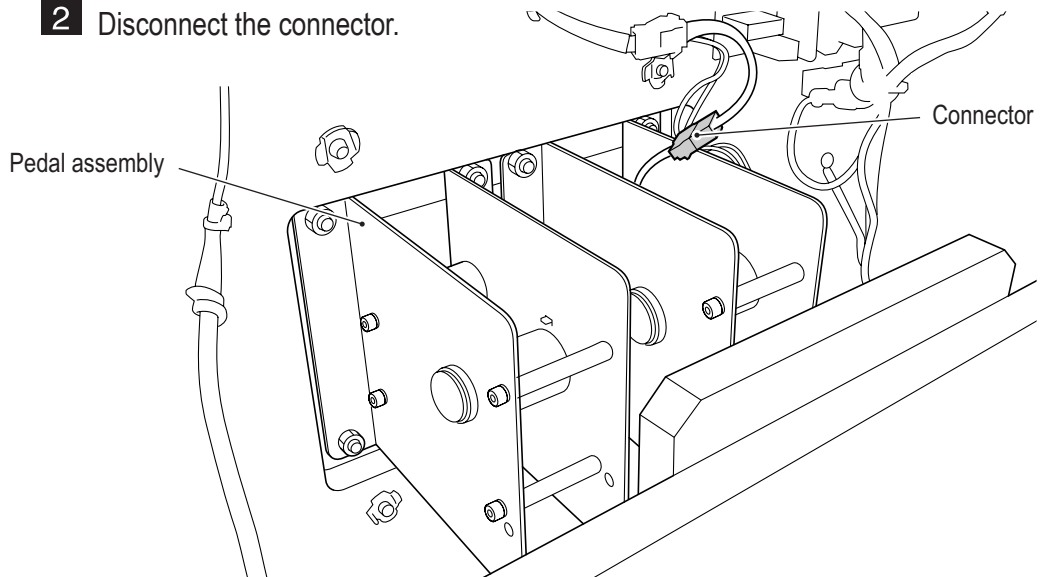

**3** Remove the four button bolts (M6 x 20), and then slowly remove the pedal assembly.

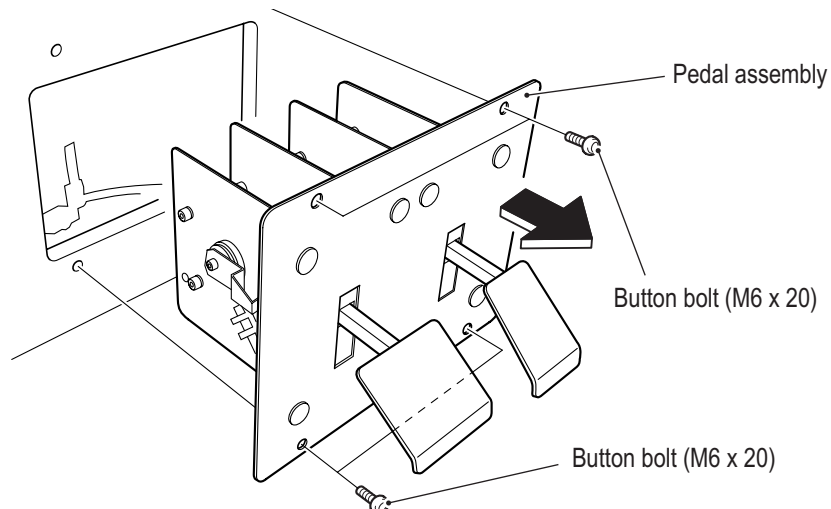

**4** To install, perform the procedure in reverse.



- After completing the replacement, be sure to check the operation and initialize. (See “7-5-4 (b) I/F INITIALIZE (STEERING & GAS)” on page 33 and “7-5-4 (c) SWITCH TEST” on page 35.)



— Must be performed by a technician —

## 8B-4-4 Seat Assembly

### (1) Replacing the Slide Unit

#### **⚠ WARNING**

- To avoid electric shock, accidents or injuries to yourself or other people, or damage to the electronic circuits, be sure to turn off the power switch before starting work.
- The slide unit and seat weigh approx. 33.1 lb. When laying down and removing the slide unit and seat, there is a danger of trapping your hands or an object. Make sure there is no one in the surrounding area.

- 1** Remove the six Phillips pan head screws (M5 x 25), remove the under cover. Then remove the 10 flange socket bolts (M6 x 30) to remove the seat slide assembly.

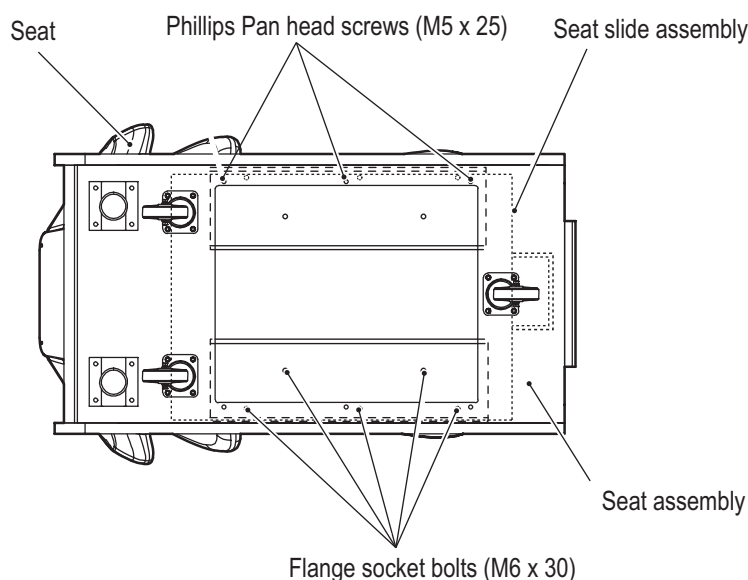

- 2** Remove the four flange socket bolts (M8 x 40), and replace the slide unit.

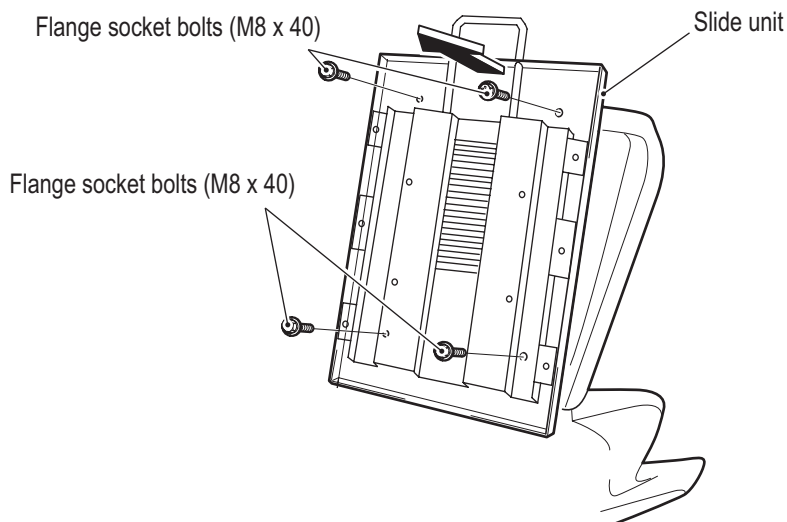

- 3** To install, perform the procedure in reverse.

— Must be performed by a technician —

(2) Replacing the LED (14.2")

**⚠ WARNING**

- To avoid electric shock, accidents or injuries to yourself or other people, or damage to the electronic circuits, be sure to turn off the power switch before starting work.

- 1** Remove the eight button bolts (M4 x 10), and then remove the acrylic cover.

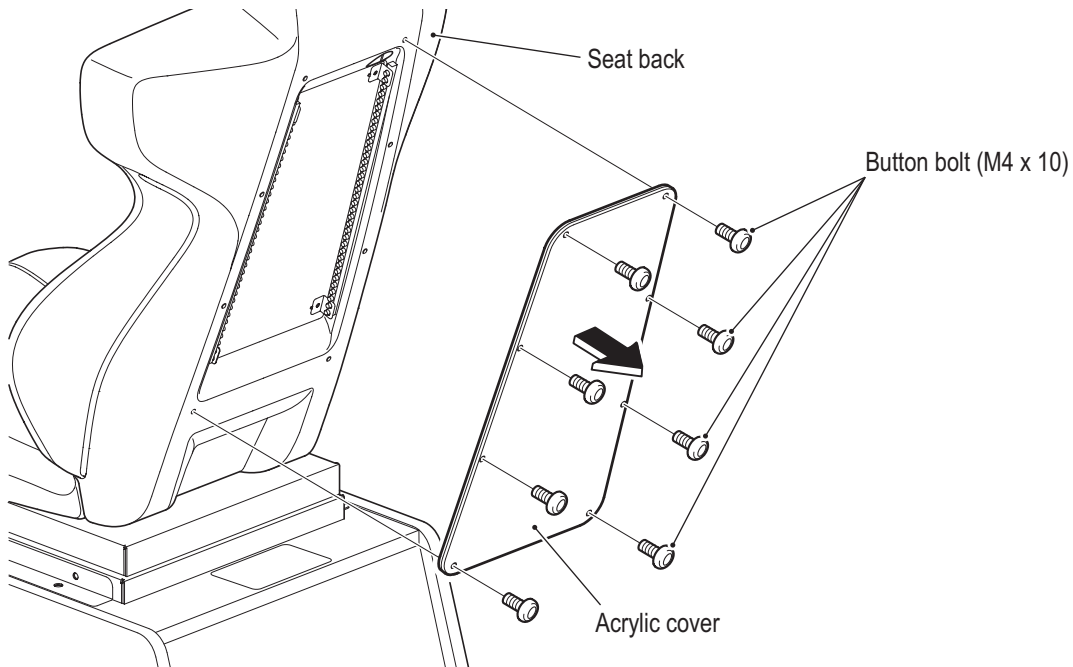

- 2** Disconnect the connector, remove the two Phillips pan head screws (4 x 12) and remove the two LED retainers and the LED (14.2").

- 3** Replace the LED (14.2"). To install, perform the procedure in reverse.

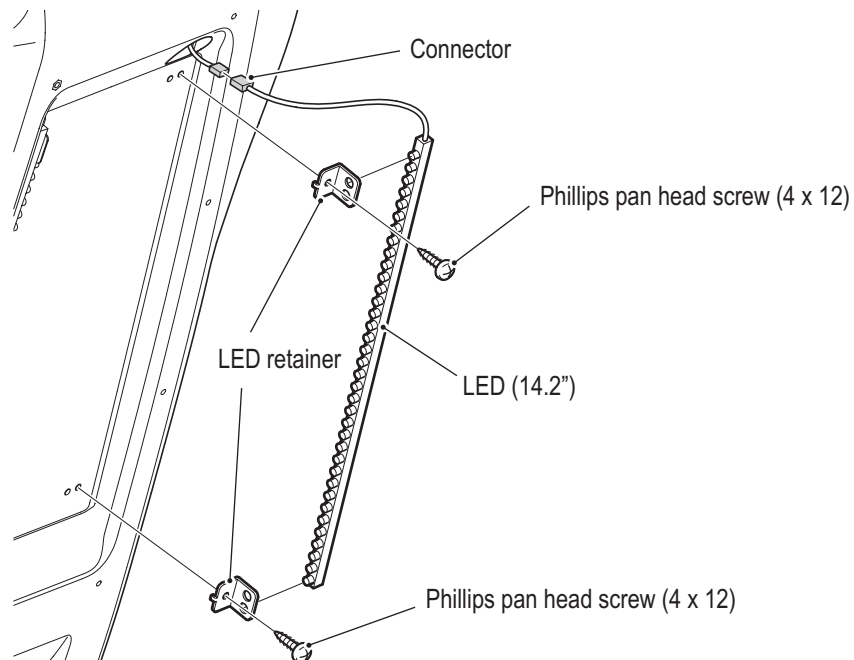

- After completing the replacement, be sure to check the operation. (See "7-5-4 (d) LAMP TEST" on page 37.)

# 9. Disposal

---

## WARNING

- When disposing of the machine, follow the applicable regulations for collection, transportation and disposal.
- When delegating the collection, transportation and disposal of the machine, be sure to delegate to specialists in each field.

# 10. Parts List

## 10-1 Front Assembly 1/2

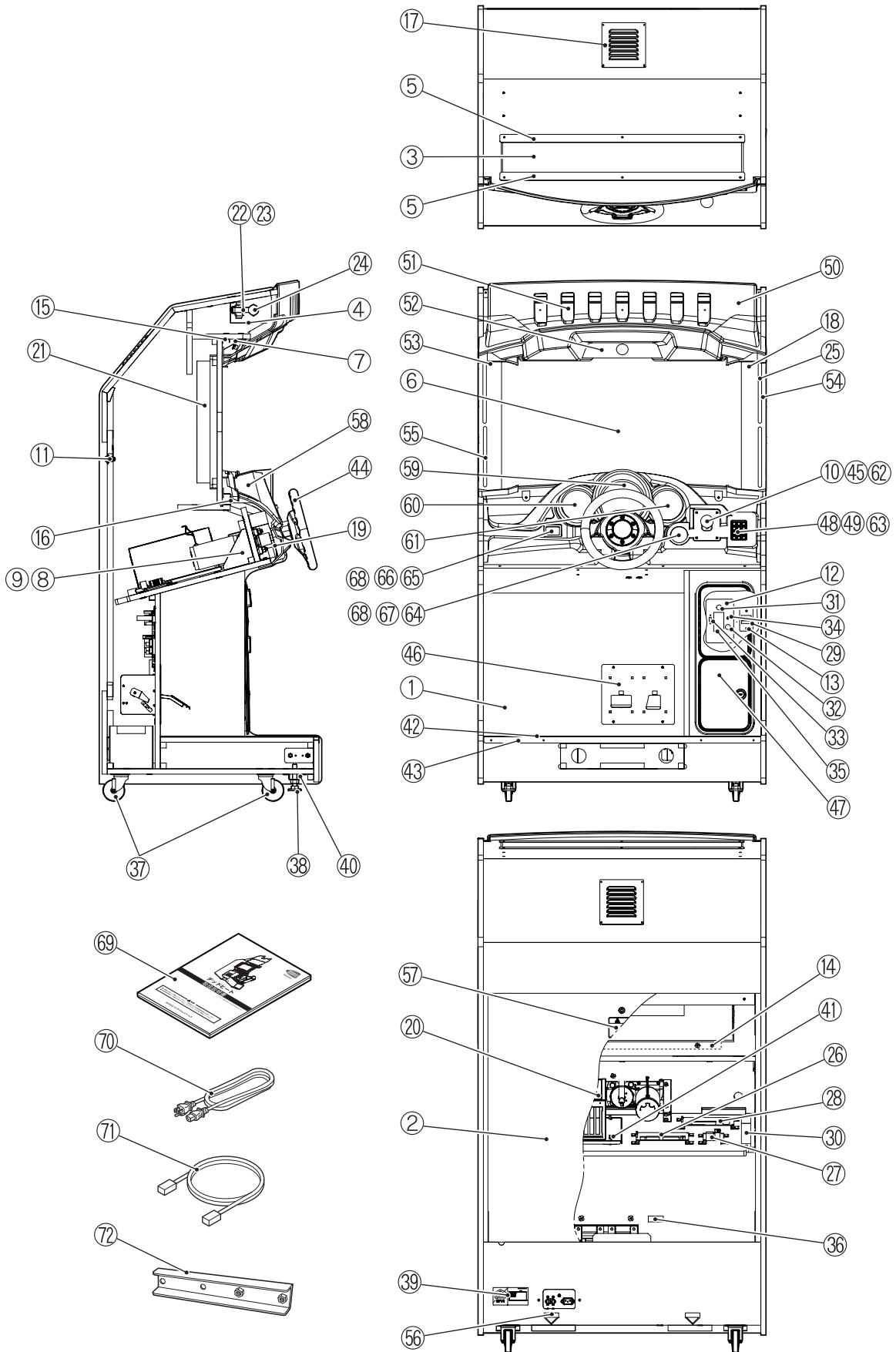

No.	Name	Qty.	Type or Rating	Part No.
1	Main Cab	1		HD63-14090-00
2	Rear door	1		HD63-14090-01
3	Fluorescent lamp panel	1		HD95-13710-00
4	Fluorescent lamp stay	1		HD10-13681-00
5	Panel retainer	1		
6	Monitor glass	1		HD99-14088-00
7	Camera stay	1		HD10-13683-00
8	Steering stay (L)	1		HD10-13684-01
9	Steering stay (R)	1		HD10-13684-00
10	Shift stay	1		HD10-13685-00
11	COIN LOCK Assembly	1		VG26-13198-00
12	Service plate	1		VG10-06881-00
13	Coin counter plate	1		
14	LCD bracket	2		
15	Glass retainer (A)	1		K198-107-000
16	Glass retainer (B)	1		HD10-13688-00
17	Ventilation panel	1	MFZnII-C,B (free from hexavalent chromium)	VG10-00066-08
18	LED retainer	1		
19	Control panel under cover	1	MFZnII-C,B (free from hexavalent chromium)	
20	SYS ES1 (B) assembly	1		HD05-13665-00
21	LCD monitor 42"	1		VG85-13091-00
22	Fluorescent lamp fitting (with fluorescent lamp)	1		
23	Glow lamp	1		
24	Fluorescent lamp	1		
25	LED	6		VG79-13743-24
26	NA-JV PC board	1		HD15-13661-00
27	Amp PC board	1		HD15-13663-00
28	Steering PC board	1		HD15-13662-00
29	Coin counter	1		
30	Power supply (12 V)	1		VG88-10064-00
31	Switch (push)	1	SDP-103C-22RB (red)	
32	Switch (push)	1	SDP-103C-22GB (green)	
33	Switch (slide)	1	SDS-103A-03#13BJ	
34	Switch (toggle)	1	SDSA-331G-CR	
35	Service sticker M (B)	1	Printed in black	
36	Current fuse (5 A)	1		
37	Caster (adjustable)	4	STC-75NM	VG24-00783-00
38	Adjustment bolt	2	M16 x 75	VG20-04938-01
39	Rating B sticker V (B)	1		

# 10-1 Front Assembly 2/2

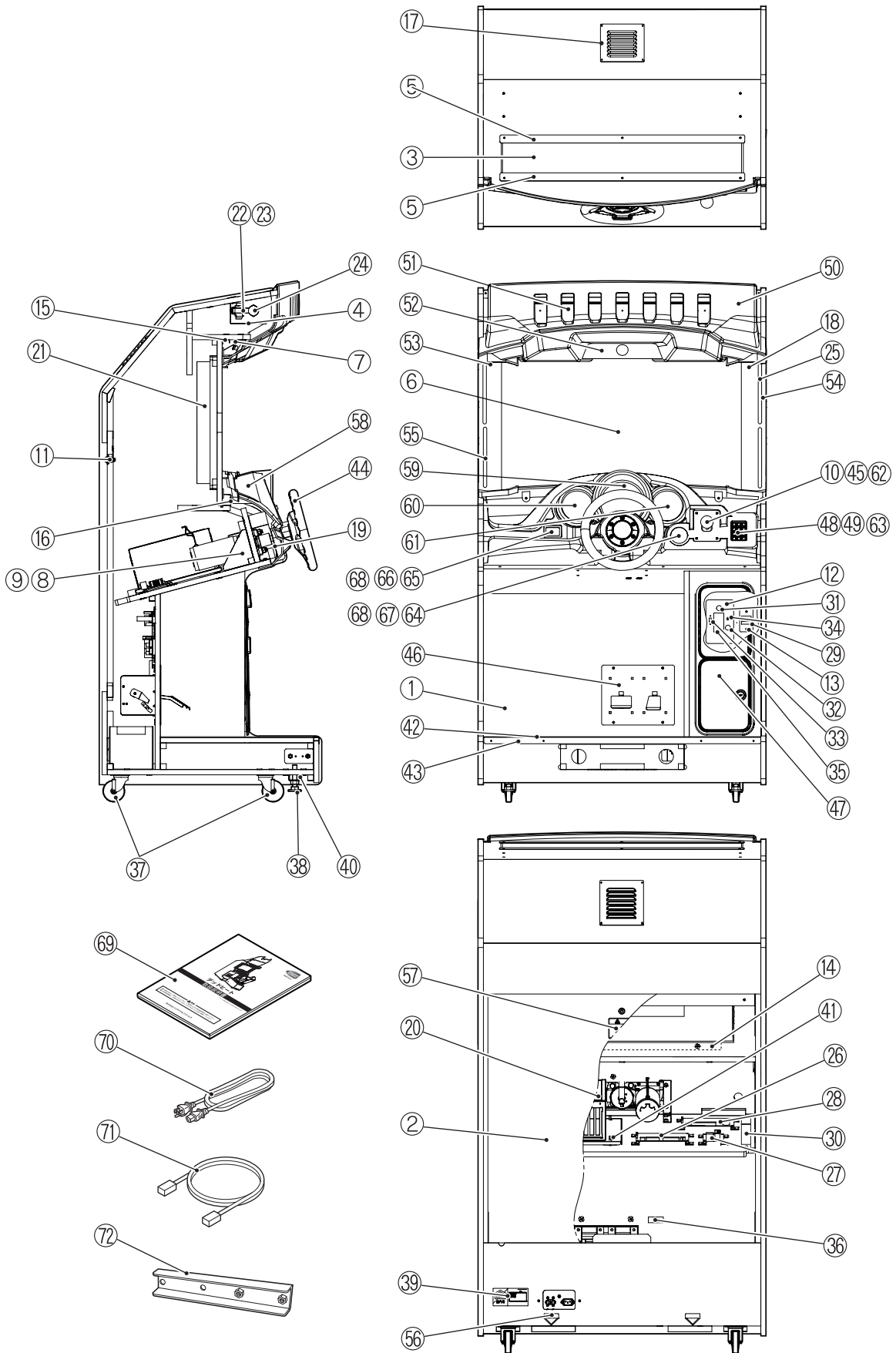

No.	Name	Qty.	Type or Rating	Part No.
40	Adjuster bracket	2		VG10-13164-00
41	Anti-vibration rubber	4	RB-20	
42	Floor mat	1		HD96-14086-00
43	Floor mat retainer	1		HD10-13691-00
44	270 active steering wheel assembly	1	50-0102-50EX	R580-09704-01
45	4-speed shifter	1	50-8496-00	VG80-13740-00
46	Dual pedal assembly paintloc std w/ms & 5k pot on gas	1	50-2661-20EX	VG05-13755-00
47	Over/under door with cashbox and full metal enclosure assembly	1	40-6000-04	VC83-13188-00
48	Keypad	1	AK-707-A-SSB-WP-MM	
49	Keypad panel	1		HD95-13745-00
50	Top cover	1		HD90-13735-02
51	Top filter	6		HD90-13736-00
52	Camera cover	1		HD40-14097-00
53	Monitor side cover (L)	1		HD10-14094-00
54	Monitor side cover (R)	1		HD10-14094-01
55	Ring	6		HD90-13666-00
56	Fork sticker	2		VG40-06882-00
57	Warning sticker maintenance (S2) EXP	1		
58	Control cover	1		HD90-13750-00
59	Meter sticker (A)	1		HD40-13721-00
60	Meter sticker (B)	1		HD40-13722-00
61	Meter sticker (C)	1		HD40-13723-00
62	Shift sticker	1		HD40-13724-00
63	Keypad sticker	1		HD40-13725-00
64	NITROUS switch sticker	1		HD40-13726-00
65	View selector sticker	1		HD40-13727-00
66	Illuminated switch (green)	1		VC53-13753-00
67	Illuminated switch (red)	1		VG53-13754-00
68	Wedge lamp	2	14 V 3.8 V	
69	Operation manual (this manual)	1		HD45-13671-00
70	Power cord	1		VG51-01232-04
71	Communication cable	1		VG50-11136-10
72	Connection bracket	2		HD10-13703-00

## 10-2 Cord Box Assembly

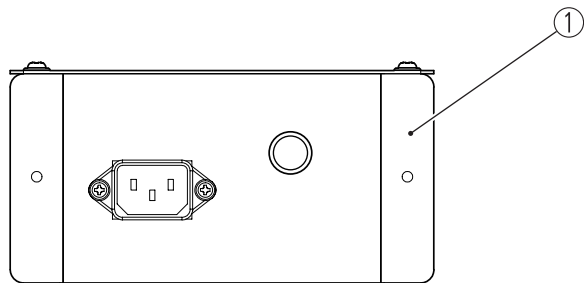
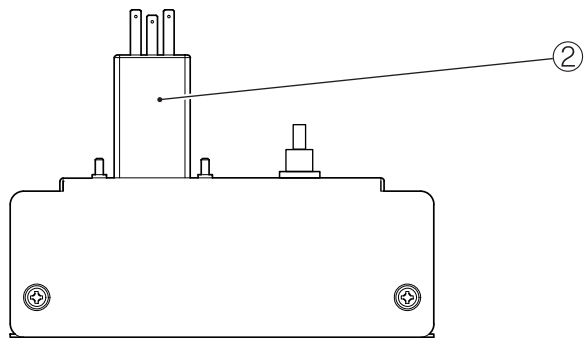

No.	Name	Qty.	Type or Rating	Part No.
1	Cord box	1		VG10-13674-00
2	Noise filter	1		VG78-12947-00



## 10-3 Signboard Assembly

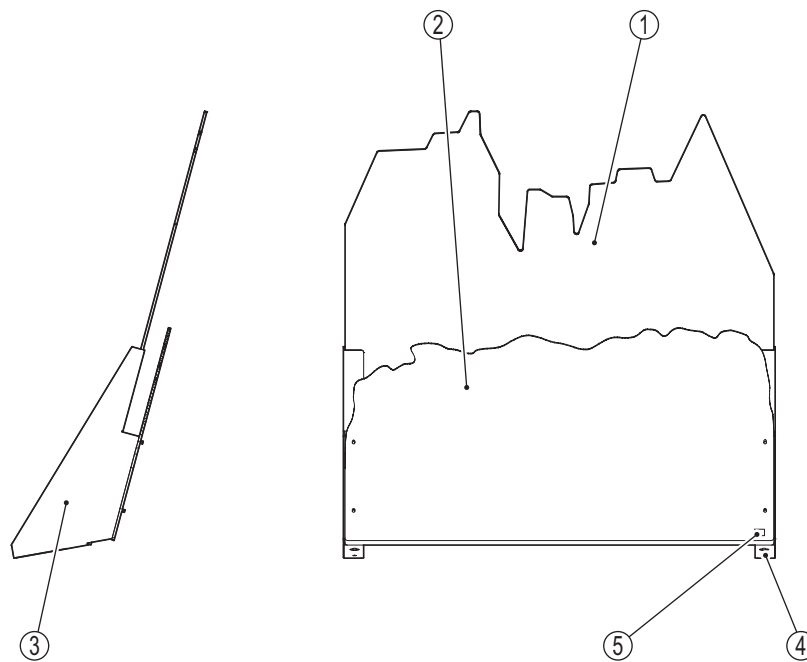

No.	Name	Qty.	Type or Rating	Part No.
1	Title panel F	1		HD40-13733-00
2	Title panel B	1		HD40-13732-00
3	Signboard stay (L)	1		HD10-13695-01
4	Signboard stay (R)	1		HD10-13695-00
5	Security system	1		VG44-13051-00

# 10-4 Seat Assembly

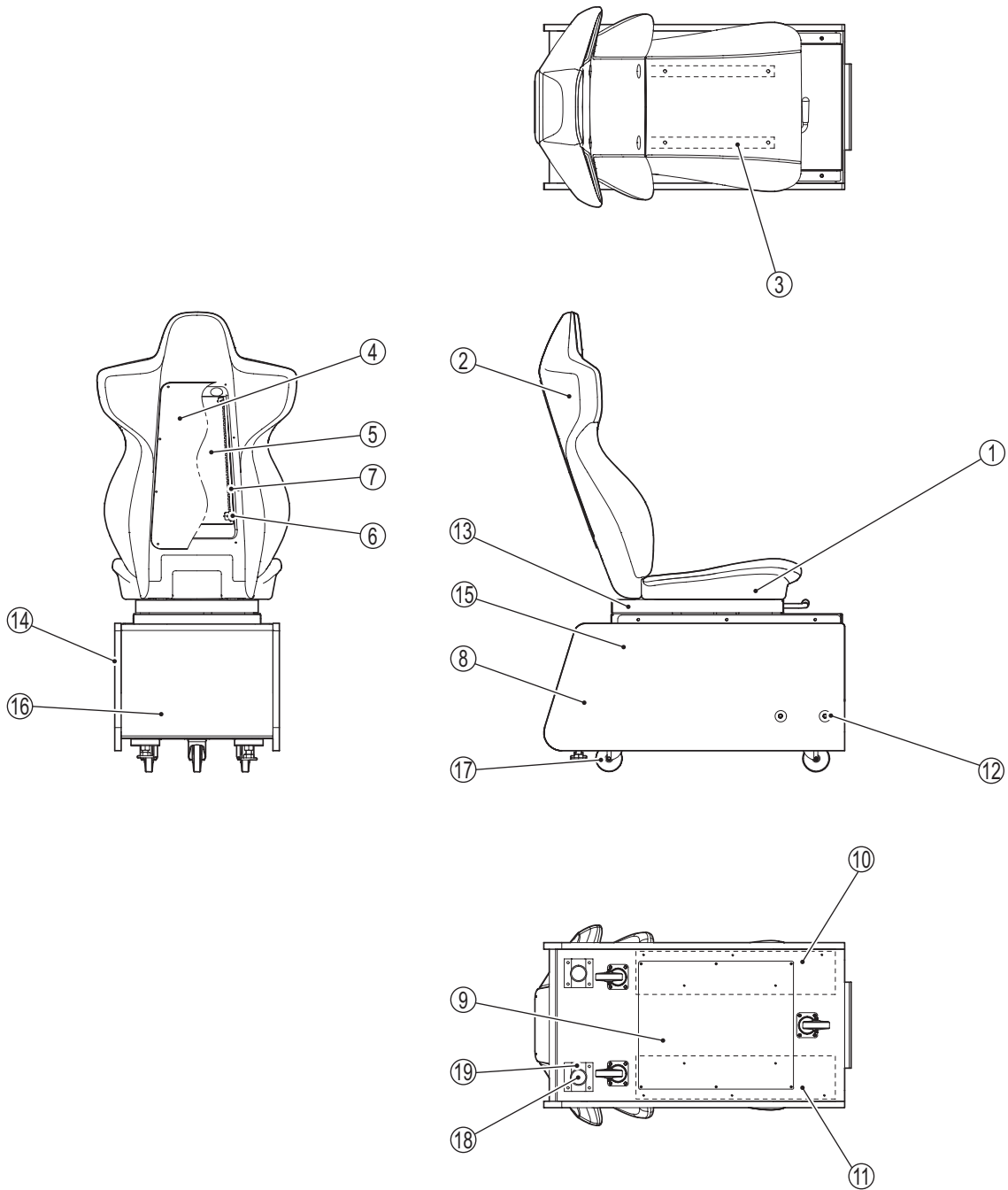



# 10-5 Pedal Assembly

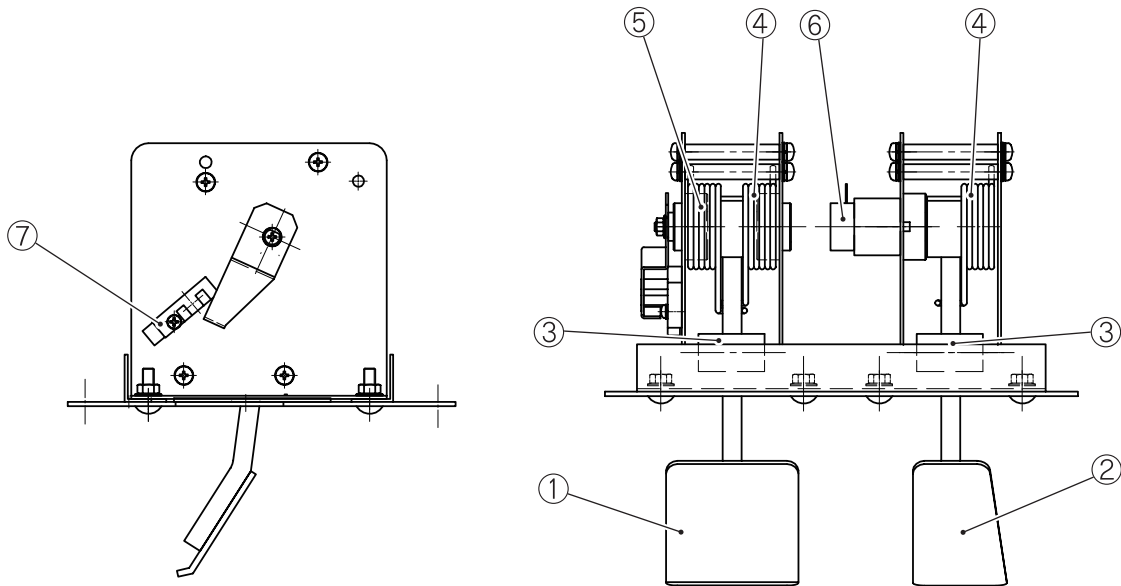

No.	Name	Qty.	Type or Rating	Part No.
1	Pedal A	1		VG05-13755-99
2	Pedal B	1		VG05-13755-98
3	Cushion	4		VG05-13755-97
4	Spring A	2		VG05-13755-96
5	Spring B	1		VG05-13755-95
6	SENSOR	1		VG05-13755-93
7	POTENTIOMETOR	1		VG05-13755-94

## 10-6 Steering Assembly

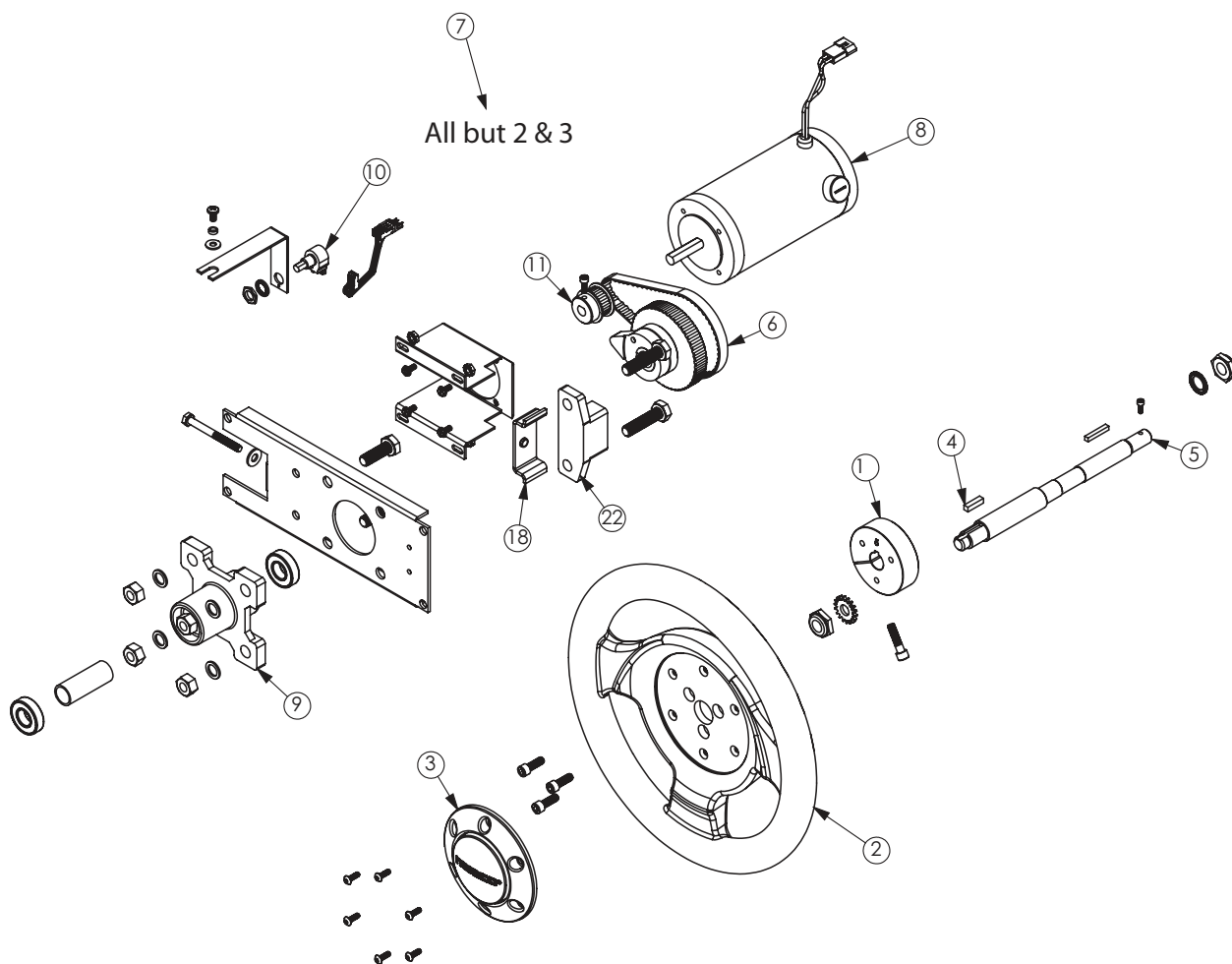

No.	Name	Qty.	Type or Rating	Part No.
1	Hub, Steering	1		DD11-04923-00
2	Steering Wheel	1		VG80-13774-00
3	Cap	1		VG90-13757-00
4	Key	1		VG80-02975-06
5	Shaft	1		VG80-02975-05
6	Timing Belt	1		VG80-02975-16
7	Feedback Steering Assembly, all but 2 & 3	1		R580-09704-01
8	Feedback Motor	1		VG59-13775-00
9	Bearing Holder	1		TW11-06148-00
10	5K Potentiometer	1		VG75-06089-01
11	Motor Gear Shaft	1		VG80-02975-17

# 10-7 Shifter Assembly

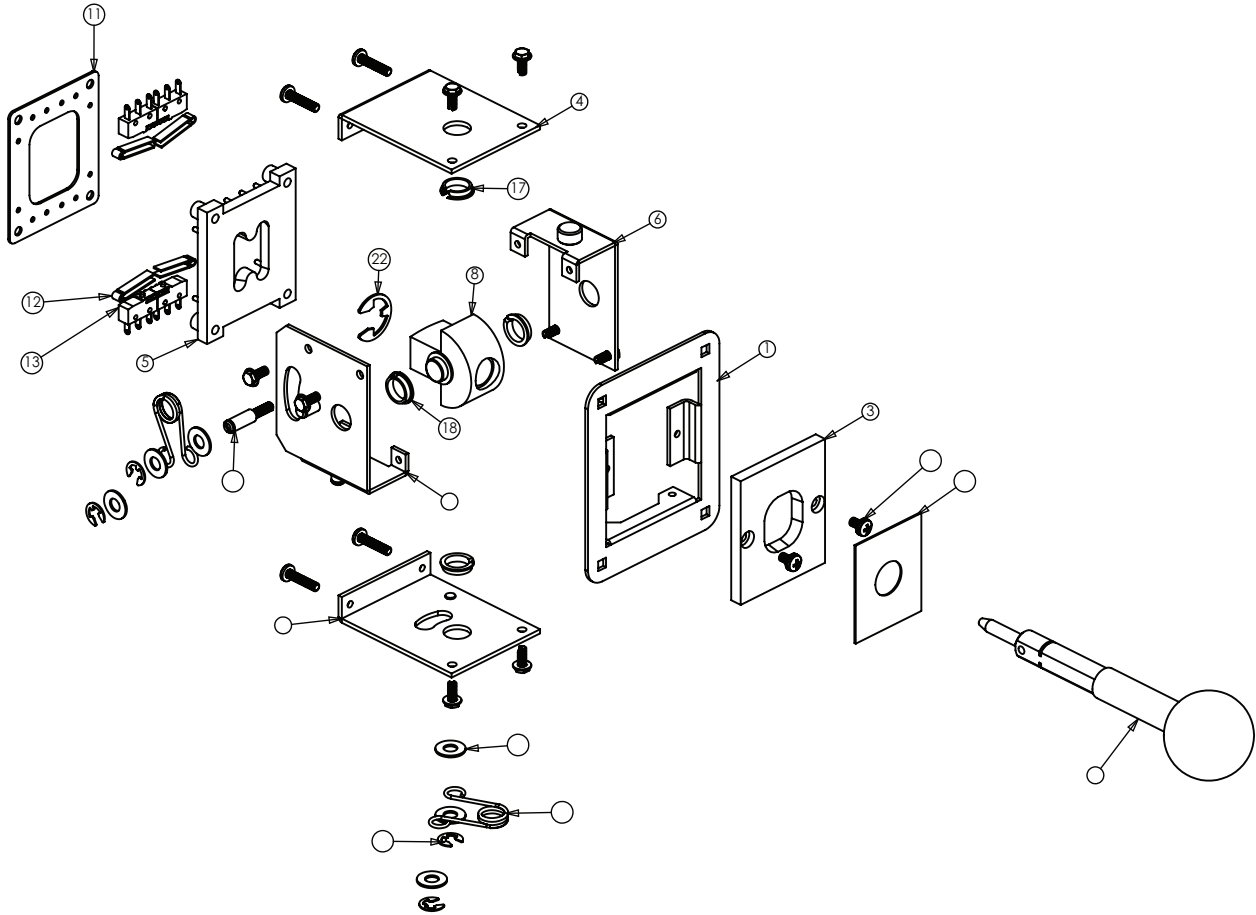

No.	Name	Qty.	Type or Rating	Part No.
1	BASE PLATE 4 SPD SHFT BLK	1		VG10-13763-00
2	SIDE BRACKET W/PIN CLR ZNC PLT	1		VG10-13759-00
3	GATE BLOCK UPPER MOLDED	1		VG90-13760-00
4	SIDE BRACKET NO PIN CLR ZNC PLT	1		VG10-13761-00
5	GATE BLOCK LOWER MOLDED	1		VG90-13762-00
6	INNER BOX A, SUB ASSY, PL	1		VG10-13763-00
7	INNER BOX B, ASSY	1		VG10-13764-00
8	TRUNNION, FOR I.L. TURBO SHIFTER	1		VG59-13765-00
9	KNOB & SHAFT ASSY 1-3/4 BLK BALL KNOB	1		VG80-13766-00
10	ANCHOR PIN, HANDLE BLK OXD.	1		VG59-13767-00
11	RETAINER PLATE	1		VG10-13768-00
12	ACTUATOR, SPRING WHEEL	1		VG22-13769-00
13	SUB-MIN CHERRY SW 1AMP 125/250V	1		VG53-13770-00
14	GUIDE WASHER, 4 SPD SHIFTER	1		VG95-13771-00
15	SPRING, HAIRPIN, HLR SHFTR, SHORT	1		VG22-13772-00

# 11 Wiring Diagrams

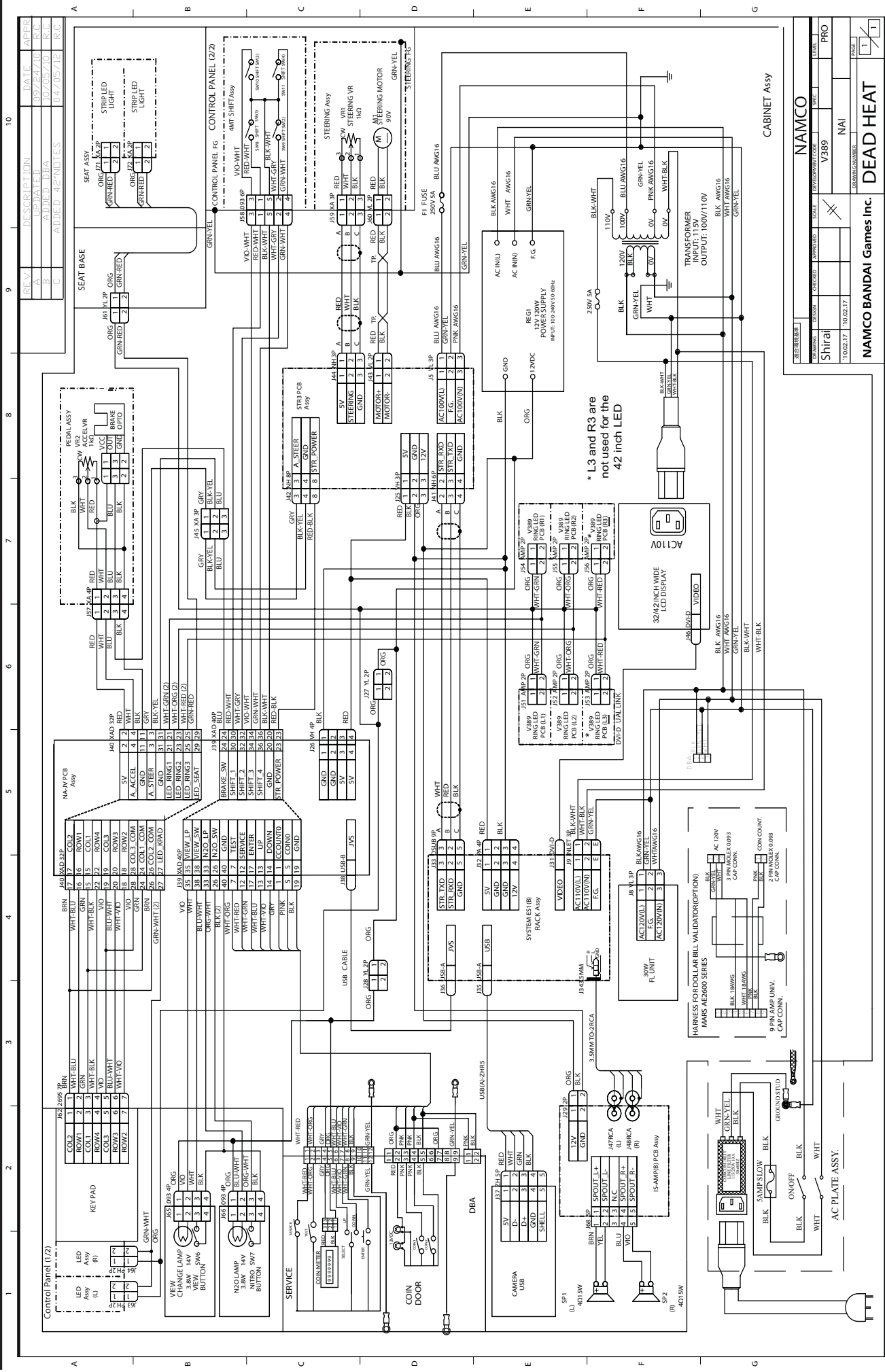

REV#	DESCRIPTION	DATE	APPR
A	REPLATED	09/24/10	RC
B	ADDED DBA	10/09/10	RC
C	ADDED 42 INCHES	04/09/12	RC

DESIGNED BY	CHECKED	APPROVED	SCALE	SYSTEM/PROJECT CODE	SPEC	LEVEL
Shiral					V389	PRO
DATE	10/02/17	10/02/17				

DRAWING NUMBER		DRAWING NAME	
NAMCO		DEAD HEAT	

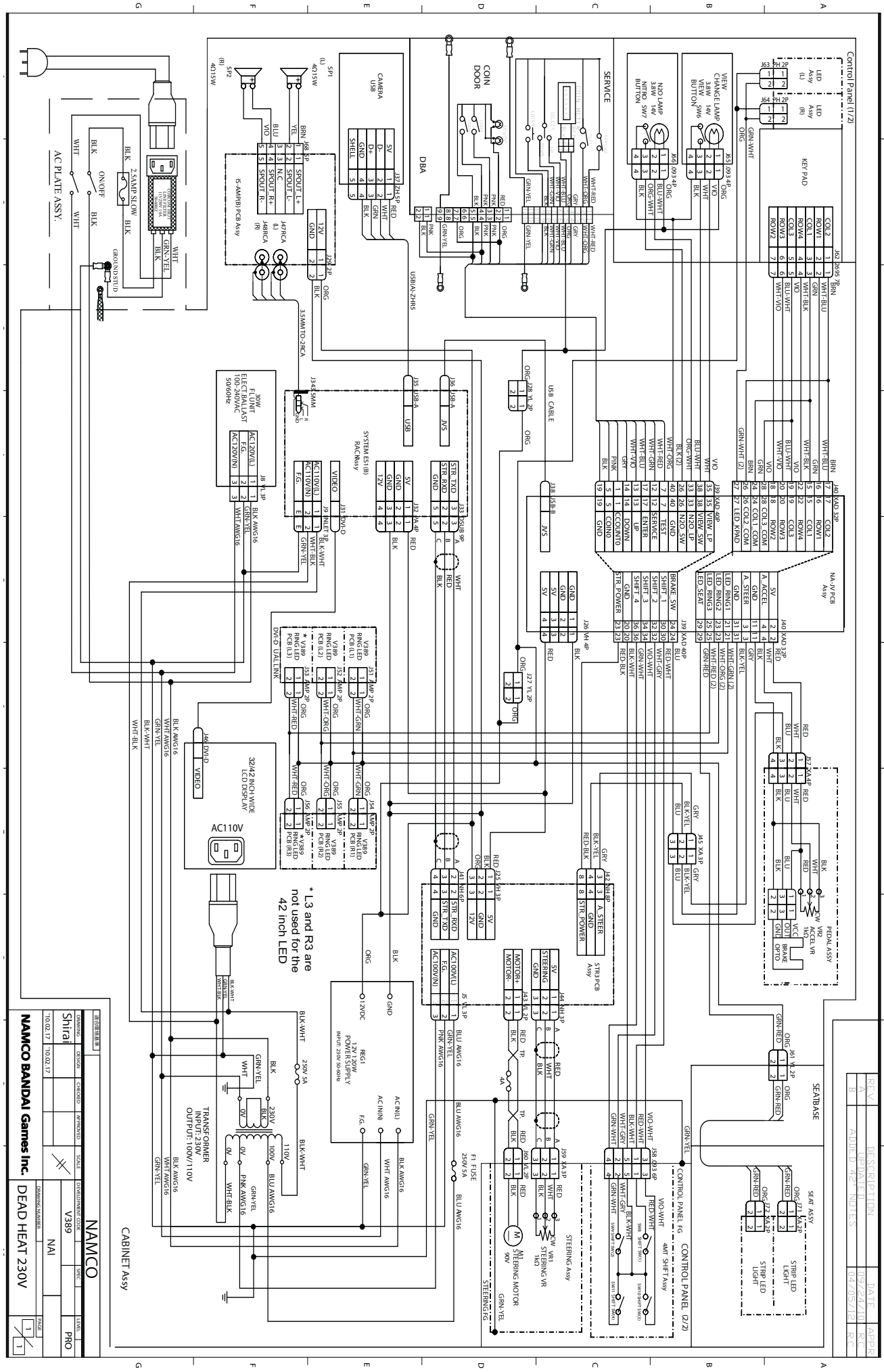

REV	DESCRIPTION	DATE	APPR
A	DEAD HEAT	09/24/10	R.C.
B	ADD UP 42" LED'S	04/05/11	R.C.

DESIGNED BY	Shital	SCALE	1" = 1"
DRAWN BY	Shital	INSTRUMENT	PRO
CHECKED BY		DATE	
DATE	10.02.17	10.02.17	

NAMCO BANDAI Games Inc.		NAMCO	
DEAD HEAT 230V		V389	
DRAWING NUMBER		NAI	
		PAGE	
		1	

CABINET Assy

\* L3 and R3 are not used for the 42 inch LED

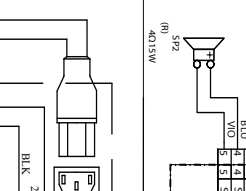
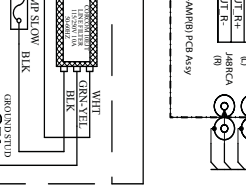
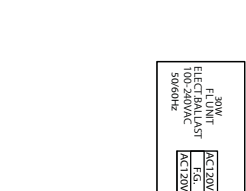
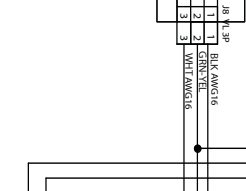
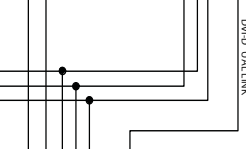
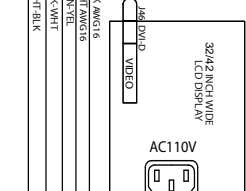

1 2 3 4 5 6 7 8 9 10





**Ray Tanzer**  
Technical Director

**Steve Ignarski**  
Part Sales Representative  
847.264.5612

**Joe Blackwell**  
Field Service Technician  
847.264.5614

© **NAMCO BANDAI Games Inc.**

First Edition Published in May 2012  
Part No: HD45-14089-00 REV A. 5-12

**namco**<sup>®</sup> America Inc.

951 Cambridge Drive  
Elk Grove Village, IL 60007-2434

FAX: (847) 264-5613