

1st PRINTING



Sega Amusements Europe Limited.
42 Barwell Business Park, Leatherhead Road, Chessington, Surrey, KT9 2NY, United Kingdom.
Telephone: +44 (0) 208 391 8090 Facsimile: +44 (0) 208 391 8099
email: mailbox@sega.co.uk Web: <http://www.segaarcade.com>

Play It! Amusements, inc.
252 Beinoris Drive, Wood Dale, IL. 60191, USA
USA Sales: +00 (1) 224 265 4287

© SEGA

SEGA SNAKES & LADDERS

OWNER'S MANUAL

420-0020UK



OWNER'S MANUAL

SEGA SNAKES & LADDERS

TM



IMPORTANT

- Before using this product, read this manual carefully to understand the contents herein stated.
- After reading this manual, be sure to keep it near the product or in a convenient place for easy reference when necessary.

BEFORE USING THE PRODUCT, BE SURE TO READ THE FOLLOWING:

To maintain safety:

To ensure the safe operation of this product, be sure to read the following before usage.

The following instructions are intended for the users, operators and the personnel in charge of the operation of the product. After carefully reading and sufficiently understanding the warning displays and cautions, handle the product appropriately. Be sure to keep this manual close to the product or in a convenient place for future reference.

Herein, explanations which require special attention are enclosed with dual lines. Depending on the potentially hazardous degrees, the terms of DANGER, WARNING, CAUTION, etc. are used. Be sure to understand the contents of the displays before reading the text.

 **DANGER** Indicates that mishandling the product by disregarding this pictograph will cause severe injury or death.

 **WARNING** Indicates that mishandling the product by disregarding this warning will cause a potentially hazardous situation which can result in death or serious injury.

 **CAUTION** Indicates that mishandling the product by disregarding this caution will cause a slight hazardous situation which can result in personal injury and/or material damage.

For the safe usage of the product, the following pictographs are used:

 Indicates "HANDLE WITH CARE." In order to protect the human body and equipment, this display is attached to places where the Owner's Manual, Serviceman Manual and/or Service Manual should be referred to.

- **Perform work in accordance with the instructions herein stated.** Instructions for work are explained by paying attention to the aspect of accident prevention. Failing to perform work as per the instructions can cause accidents. In the case where only those who have technical expertise should perform the work to avoid hazardous situation, the instructions herein state that the site maintenance personnel should perform such work.
- **Be sure to turn off the power before working on the machine.** To prevent an electric shock, be sure to turn off the power before carrying out any work that requires direct contact with the interior of the product. If the work is to be performed in the power-on status, the Instruction Manual herein always states to that effect.
- **Be sure to ground the Earth Terminal.** (This is not required in the case where a power cord with earth is used.)
- **This product is equipped with the Earth Terminal.** When installing the product, connect the Earth Terminal to the "accurately grounded indoor earth terminal" by using an earth wire. Unless the product is grounded appropriately, the user can be subject to an electric shock. After performing repair, etc. for the control equipment, ensure that the Earth Wire is firmly connected to the control equipment.
- **Ensure that the Power Supply used is equipped with an Earth Leakage Breaker.** This product does not incorporate the Earth Leakage Breaker. Using a power supply which is not equipped with the Earth Leakage Breaker can cause a fire when earth leakage occurs.
- **Be sure to use fuses which meet the specified rating.** (Only for the machines which use fuses.) Using fuses exceeding the specified rating can cause a fire and an electric shock. (Only for the machines which use fuses.) Using fuses exceeding the specified rating can cause a fire and an electric shock.

- **Specification changes (removal of equipment, conversion and addition) not designated by SEGA are not allowed.** The parts of the product include warning labels for safety, covers for personal protection, etc. It is very hazardous to operate the product by removing parts and/or modifying the circuits. Should doors, lids and protective parts be damaged or lost, refrain from operating the product, and contact where the product was purchased from or the office herein stated. SEGA shall not be held responsible for any accidents, compensation for damage to a third party, resulting from the specifications not designated by SEGA.
- Ensure that the product meets the requirements of appropriate electrical specifications. Before installing the product, check for electrical specifications. SEGA products have a nameplate on which electrical specifications are described. Ensure that the product is compatible with the power supply voltage and frequency requirements of the location. Using any electrical specifications different from the designated specifications can cause a fire and an electric shock.
- Install and operate the product in places where appropriate lighting is available, allowing warning labels to be clearly read. To ensure safety for the customers, labels and printed instructions describing potentially hazardous situations are applied to places where accidents can be caused. Ensure that where the product is operated has sufficient lighting allowing the warnings to be read. If any label is peeled off, apply it again immediately. Please place an order with where the product was purchased from or the office herein stated.
- When handling the monitor, be very careful. (Applies only to products with monitors.) Some of the monitor parts are subject to high tension voltage. Even after turning off the power, some portions are still subject to high tension voltage sometimes. Monitor repair and replacement should be performed only by those technical personnel who have knowledge of electricity and technical expertise.
- Be sure to adjust the monitor properly. (Applies only to products with monitors.) Do not operate the product leaving on-screen flickering or blurring as it is. Using the product with the monitor not properly adjusted may cause dizziness or a headache to an operator, a player, or the customers.
- When transporting or reselling this product, be sure to attach this manual to the product.
- *In the case where commercially available monitors and printers are used in this product, only the contents relating to this product are explained herein. Some commercially available equipment has functions and reactions not stated in this manual. Read this manual together with the specific instruction manual of such equipment.*
- *Descriptions herein contained may be subject to improvement changes without notice.*
- *The contents described herein are fully prepared with due care. However, should any question arise or errors be found, please contact SEGA.*

INSPECTIONS IMMEDIATELY AFTER TRANSPORTING THE PRODUCT TO THE LOCATION

Normally, at the time of shipment, SEGA products are in a status allowing for usage immediately after transporting to the location. Nevertheless, an irregular situation may occur during transportation. Before turning on the power, check the following points to ensure that the product has been transported in a satisfactory status.

- Are there any dented portions or defects (cuts, etc.) on the external surfaces of the cabinet?
- Are casters and adjusters damaged?
- Do the power supply voltage and frequency requirements meet with those of the location?
- Are all wiring connectors correctly and securely connected? Unless connected in the correct way, connector connections can not be made accurately. Do not insert connectors forcibly.
- Do power cables have cuts and dents?
- Are all accessories available?
- Can all doors and lids be opened with the accessory keys? Can doors and lids be firmly closed?

INTRODUCTION

This manual is intended to provide detailed descriptions together with all necessary information covering the general operation of electronic assemblies, electro-mechanicals, servicing control, spare parts, etc. for the product, "SEGA'S SNAKES AND LADDERS"

This manual is intended for the owners, personnel managers in charge of operation of this product. Operate the product after carefully reading and sufficiently understanding the instructions.

In the unlikely event that the product does not function correctly, DO NOT allow anyone other than a technician to touch the internal system. Turn off the power to the machine, making sure to unplug the electrical cord from the outlet, and contact the office listed below or the point-of-purchase for this product.

Use of this product is unlikely to cause physical injuries or damage to property. However, points that require special attention are indicated by bold text, the word "IMPORTANT" and the symbol below.



Indicates important information that, if ignored, may result in the mishandling of the product and cause faulty operation or damage to the product.

Sega Amusements Europe Limited.

42 Barwell Business Park, Leatherhead Road, Chessington, Surrey, KT9 2NY. United Kingdom.

Telephone: +44 (0) 208 391 8090 Facsimile: +44 (0) 208 391 8099
email: sales@segaarcade.com Web: <http://www.segaarcade.com>.

Sega Total Solutions

42 Barwell Business Park, Leatherhead Road, Chessington, Surrey, KT9 2NY. United Kingdom.

Telephone: +44 (0) 208 391 8060 Facsimile: +44 (0) 208 391 8096
email: sales@segaarcade.com Web: <http://www.segaarcade.com/spares>

Play it! Amusements

252 Beinoris Drive, Wood Dale, IL. 60191, USA

USA Sales/Service +00(1) 224 265 4287

SPECIFICATIONS

Machine Dimensions:

Cabinet w/o Billboard & Body (3) 0,99m (39in.) [Width] x 0.85m (33.5in.) [Depth]
2.24m (88.2in.) [Height]

Cabinet with Billboard 1.38m (54.3in.) [Width] x 0.85m (33.5in.) [Depth]
2.73m (107.4in.) [Height]

Weight: 120Kg

Electrical Consumption

Operating Voltage AC240V (switchable to AC120V via PSU)
Current 0.4A @ AC240V
0.4A @ AC220V
0.6A @ AC120V

Definition of 'Site Maintenance Personnel or Other Qualified Individuals'



Procedures not described in this manual or marked as 'to be carried out by site maintenance personnel or other qualified professionals' should not be carried out by personnel without the necessary skill or technology. Work carried out by unqualified persons may cause serious accidents, including electrocution.

Parts replacement, maintenance inspections and troubleshooting should be carried out by site maintenance personnel or other qualified professionals. This manual includes directions for potentially dangerous procedures which should only be carried out by professionals with the appropriate specialised knowledge.

The site maintenance personnel or other qualified professionals mentioned in this manual are defined as follows:

Site maintenance personnel:

Individuals with experience in maintaining amusement equipment, vending machines, etc., working under the supervision of the owner/operator of this product to maintain machines within amusement facilities or similar premises by carrying out everyday procedures such as assembly, maintenance inspections, and replacement of units/expendable parts.

Activities to be carried out by site maintenance personnel:

Amusement equipment/vending machine assembly, maintenance inspection and replacement of units/expendable parts.

Other qualified professionals:

Persons employed by amusement equipment manufacturers, or involved in design, production, testing or maintenance of amusement equipment. The individual should have either graduated from technical school or hold similar qualifications in electrical/electronics/mechanical engineering.

Activities to be carried out by other qualified professionals:

Amusement equipment/vending machine assembly, repair/adjustment of electrical/electronic/mechanical parts.

Waste of Electrical and Electronic Equipment (WEEE) Statement.

The WEEE (Waste of Electrical and Electronic Equipment) directive places an obligation on all EU based manufacturers and importers of Electrical and Electronic Equipment to take back products at the end of their useful life. Sega Amusements Europe Ltd accepts its responsibility to finance the cost of treatment and recovery of redundant WEEE in the United Kingdom in accordance with the specified WEEE recycling requirements.

The symbol shown below will be on all products manufactured from 13th August 2005, which indicates this product must NOT be disposed of with other normal waste. Instead, it is the user's responsibility to dispose of their waste equipment by arranging to return it to a designated UK collection point for the correct recycling of waste electrical and electronic equipment.

For more information about where you can send your waste equipment for recycling contact your local authority office.

For non-UK users contact your local authority office for information on the recycling of Waste Electrical and Electronic Equipment.

Battery Recycling Statement.

The EC Directive on Batteries and Accumulators (2006/66/EC) aims to minimise the impact of batteries on the environment and encourage the recovery of the materials they contain. To achieve increased collection and recycling of waste batteries, the Directive places 'producer responsibility' obligations on manufacturers and importers of portable, industrial and automotive batteries.

The symbol shown below will be on all equipment fitted with batteries from 26th September 2008 and indicates they must NOT be disposed of with other normal waste. Instead, it is the user's responsibility to dispose of used batteries by arranging to return them to a designated collection point for the correct recycling.

For more information about where you can send your waste batteries for recycling contact your local authority office.



REGISTERED IN ENGLAND REGISTERED NO. 1711515

REGISTERED OFFICE: BLOCK C 42 BARWELL BUSINESS PARK, CHESSINGTON, SURREY KT9 2NY

RoHS Statement.

Sega amusements europe are to the best of our knowledge acting in accordance with the European Union RoHS2 Directive 2011/65/EU and hereby declare that RoHS2 restricted substances are not intentionally added to this product over the permitted limits.

These limits are:

- Lead (0.1%)
- Mercury (0.1%)
- Cadmium (0.1%)
- Hexavalent chromium (0.1%)
- Polybrominated biphenyls (0.1%)
- Polybrominated diphenyl ethers (PBDE) (0.1%)

Products containing the substances listed above are in concentration levels of that below the maximum limits and are understood to be in compliance with Directive 2011/65/EU of the European Parliament.

TABLE OF CONTENTS

| | |
|---|------------|
| INTRODUCTION | iii |
| 1 HANDLING PRECAUTIONS | 1 |
| 2 PRECAUTIONS REGARDING INSTALLATION | 4 |
| 3 PRECAUTIONS REGARDING OPERATION | 7 |
| 4 PART DESCRIPTIONS | 10 |
| 5 ACCESSORIES | 11 |
| 6 ASSEMBLY AND INSTALLATION | 13 |
| 6-1 INSTALLING THE CABINET | 14 |
| 6-2 FIXATION TO SITE | 22 |
| 6-3 POWER SUPPLY AND OTHER CONNECTIONS | 24 |
| 6-4 TURNING ON THE POWER | 25 |
| 7 PRECAUTIONS WHEN MOVING THE MACHINE | 27 |
| 7-1 PRECAUTIONS WHEN MOVING FROM SITE | 28 |
| 9 EXPLANATION OF TEST AND DATA DISPLAY | 31 |
| 9-1 SWITCH UNIT AND COIN METER. | 32 |
| 9-2 TEST MENU | 32 |
| 10 CONTROLLER UNIT(S) | 44 |
| 10-1 AJUSTING/CHANGING THE POT | 45 |
| 10-2 GREASING | 49 |
| 11 FEATURE REEL / TRACKER | 50 |
| 12 COIN HANDLING | 54 |
| 12-1 CLEANING THE COIN SELECTOR | 54 |
| 12-2 FAULT FINDING | 57 |
| 12-3 ADJUSTING THE PRICE OF PLAY (EXCEL) | 58 |
| 13 LAMPS AND LIGHTING | 62 |
| 13-1 REPLACING THE COIN DOOR LAMP | 62 |
| 13-2 REPLACING THE LADDER / WINLINE LED's | 63 |
| 13-3 REPLACING THE 5 DIGIT NUMERIC DISPLAY | 65 |
| 13-4 REPLACING THE LED (WHT) SNAKE BODY | 67 |
| 13-5 REPLACING THE LED (WHT) FEATURE REEL / TRACKER | 69 |
| 13-6 REPLACING THE LED (RGB) PULL | 71 |
| 14 PERIODIC INSPECTION | 72 |
| 15 TROUBLESHOOTING | 74 |
| 11-1 TROUBLESHOOTING (WHEN NO ERROR MESSAGE IS SHOWN) | 74 |

| | | |
|-----------|-------------------------------|------------|
| 16 | GAME BOARD | 77 |
| 17 | DESIGN-RELATED PARTS | 96 |
| 18 | PARTS LIST | 97 |
| 19 | WIRE COLOUR CODE TABLE | 117 |
| 20 | WIRING DIAGRAMS | 118 |

1 HANDLING PRECAUTIONS

When installing or inspecting the machine, be very careful of the following points and pay attention to ensure that the player can enjoy the game safely.

Noncompliance with the following points or inappropriate handling running counter to the cautionary matters herein stated can cause personal injury or damage to the machine.

WARNING

Before performing work, be sure to turn the power off. Performing the work without turning the power off can cause an electric shock or short circuit. In cases where work should be performed in the status of power on, this manual always states to that effect.

To avoid an electric shock or short circuit, do not plug in or unplug quickly.

To avoid an electric shock, do not plug in or unplug with a wet hand.

Do not expose power cords or earth wires on the surface, (floor, passage, etc.) If exposed, the power cords and earth wires are susceptible to damage. Damaged cords and wires can cause an electric shock or short circuit.

To avoid causing a fire or an electric shock, do not put things on or damage the power cords.

When or after installing the product, do not unnecessarily pull the power cord. If damaged, the power cord can cause a fire or an electric shock.

In case the power cord is damaged, ask for a replacement through where the product was purchased from or the office herein stated. Using the cord as is damaged can cause fire, an electric shock or leakage.

Be sure to perform grounding appropriately. Inappropriate grounding can cause an electric shock.

Be sure to use fuses meeting the specified rating. Using fuses exceeding the specified rating can cause a fire or an electric shock.

Be sure that connections such as IC BD are made properly. Insufficient insertion can cause an electric shock.

Specification changes, removal of equipment, conversion and/or addition, not designated by SEGA are not permitted.

Failure to observe this may cause a fire or an electric shock. Non-compliance with this instruction can have a bad influence upon physical conditions of the players or the onlookers, or result in injury during play.

SEGA shall not be held responsible for damage, compensation for damage to a third party, caused by specification changes not designated by SEGA.

Do not perform any work or change parts not listed in this manual. Doing so may lead to an accident.

If you need to perform any work not listed in this manual, request work from the office indicated in this manual or the point of purchase, or inquires for details.

Be sure to perform periodic maintenance inspections herein stated.

STOP IMPORTANT

For the IC board circuit inspections, only the use of a logic tester is recommended. Using a Multi Tester or General Purpose Tester may result in damage to IC Circuits.

Static electricity from your body may damage some electronics devices on the IC board. Before handling the IC board, touch a grounded metallic surface so that the static electricity can be discharged.

This video gaming cabinet utilises a motorised steering feedback system. Do not attempt to service this part or any other part in close proximity to the steering mechanism whilst power is applied.

Some parts are not designed and manufactured specifically for this game machine. The manufacturers may discontinue, or change the specifications of such general-purpose parts. If this is the case, SEGA cannot repair or replace a failed game machine whether or not a warranty period has expired.

CONCERNING THE STICKER DISPLAY

This SEGA product has stickers attached describing the product manufacture No. (Serial No.) and Electrical Specifications. It also has a Sticker describing where to contact for repair and for purchasing parts. When inquiring about or asking for repairs, mention the Serial No. and Name of Machine indicated on the Sticker. The Serial Number indicates the product register. Identical machines could have different parts depending on the date of production. Also, improvements and modifications might have been made after the publication of this manual. In order to ensure you order the correct parts, mention the Serial No. when contacting the applicable places.

CONCERNING WARNING DISPLAYS

This SEGA product has warning displays on stickers, labels and/or printed instructions adhered/attached to or incorporated in the places where a potentially hazardous situation could arise. The warning displays are intended for accident prevention for customers and for avoiding hazardous situations relating to maintenance and servicing work. Some portions of the cabinet contain high voltage and may cause accidents if touched. When performing maintenance, be very careful of the warning displays. It is especially important that any complex repair and replacement work not mentioned herein should be performed by those technical personnel who have knowledge of electricity and technical expertise. In order to prevent accidents, caution any customer ignoring the warnings to cease and desist immediately.

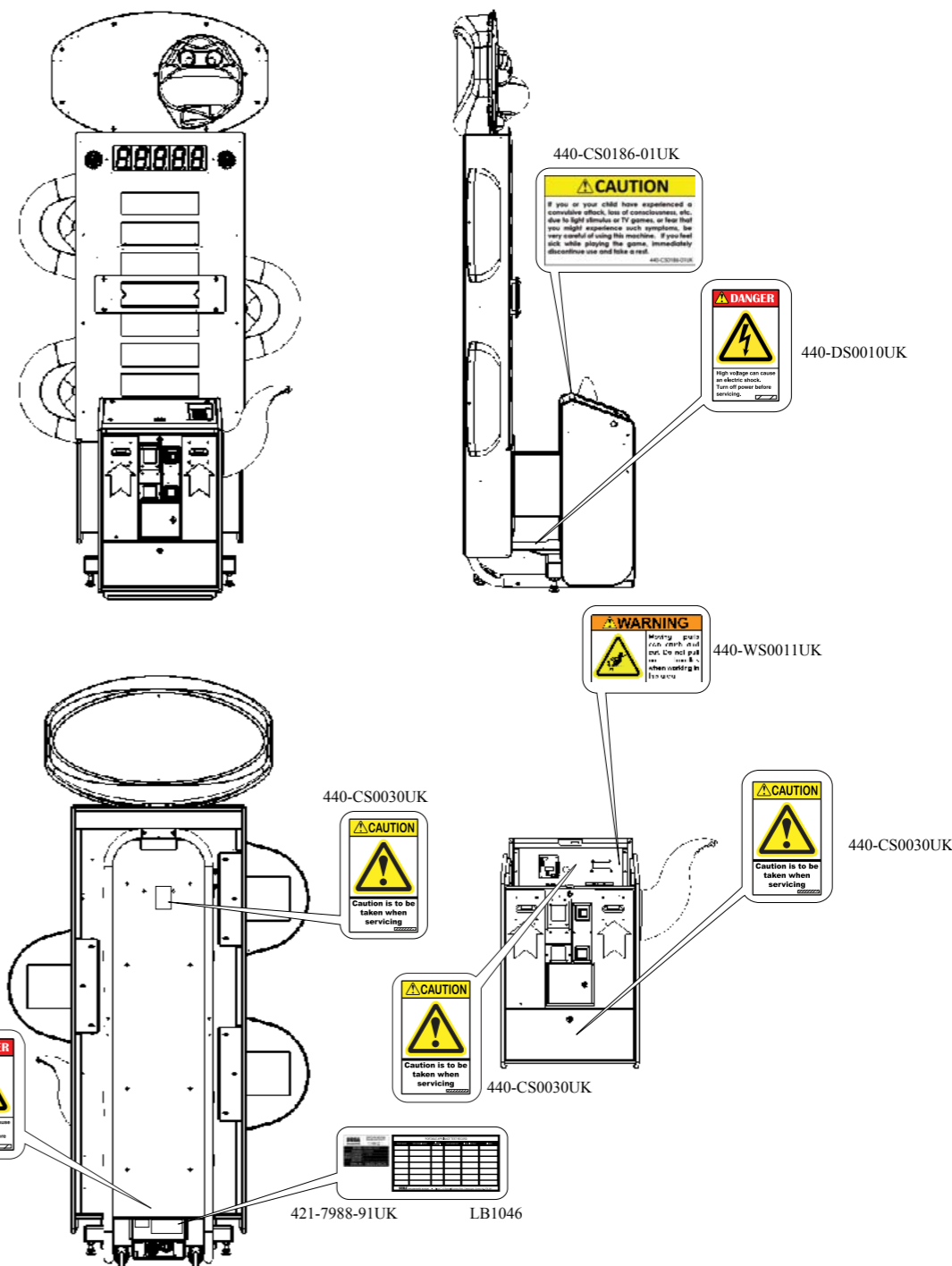

2 PRECAUTIONS REGARDING INSTALLATION

⚠ WARNING

This product is an indoor game machine. Do not install it outside. Even indoors, avoid installing in places mentioned below so as not to cause a fire, electric shock, injury and/or malfunction.

Places subject to rain or water leakage, or places subject to high humidity in the proximity of an indoor swimming pool and/or shower, etc.

Places subject to direct sunlight, or places subject to high temperatures in the proximity of heating units, etc.

Places filled with inflammable gas or vicinity of highly inflammable/volatile chemicals or hazardous matter.

Dusty places.

Sloped surfaces.

Places subject to any type of violent impact.

Vicinity of anti-disaster facilities such as fire exits and fire extinguishers.

Areas where the temperature exceeds the applicable temperature (ambient temperature) range of 5 to 30 degrees centigrade.

LIMITATIONS OF USAGE

⚠ WARNING

Be sure to check the Electrical Specifications. Ensure that this product is compatible with the location's power supply, voltage, and frequency requirements. A plate describing Electrical Specifications is attached to the product. Non-compliance with the Electrical Specifications can cause a fire and electric shock.

This product requires a breaker and earth mechanism as part of the location facilities. Using the product without these can cause a fire and electric shock.

Ensure that the indoor wiring for the power supply is rated at 15 A or higher (AC single phase 100 V ~ 120 V area), and 7 A or higher (AC 220 V ~ 240 V area). Non-compliance with the Electrical Specifications can cause a fire and electric shock.

Be sure to use an independent power supply equipped with an earth leakage breaker. Using a power supply without an earth leakage breaker can cause an outbreak of fire if a power surge occurs.

Putting many loads on one electrical outlet can cause generation of heat and a fire resulting from overload.

When using an extension cord, ensure that the cord is rated at 7A or higher (AC 100 V ~ 120 V area) and 3A or higher (AC 220 V ~ 240 V area). Using a cord rated lower than the specified rating can cause a fire and electric shock.

STOP IMPORTANT

Securing a safe area for operation as described in this manual will ensure safe operation for players and observers.

SEGA shall not be held responsible for damage or compensation for damage to a third party, resulting from the failure to observe this instruction.

OPERATION AREA (SINGLE CABINET)

⚠ WARNING

For the operation of this machine, please secure a minimum area of 1.4m (D) and 1.44m (W)

Be sure to provide sufficient space specified in this manual. Do not allow objects to block the ventilation ports. It can cause generation of heat and a fire.

Sufficient space either side of the playing area must be allowed for the player to enter or exit the game safely.

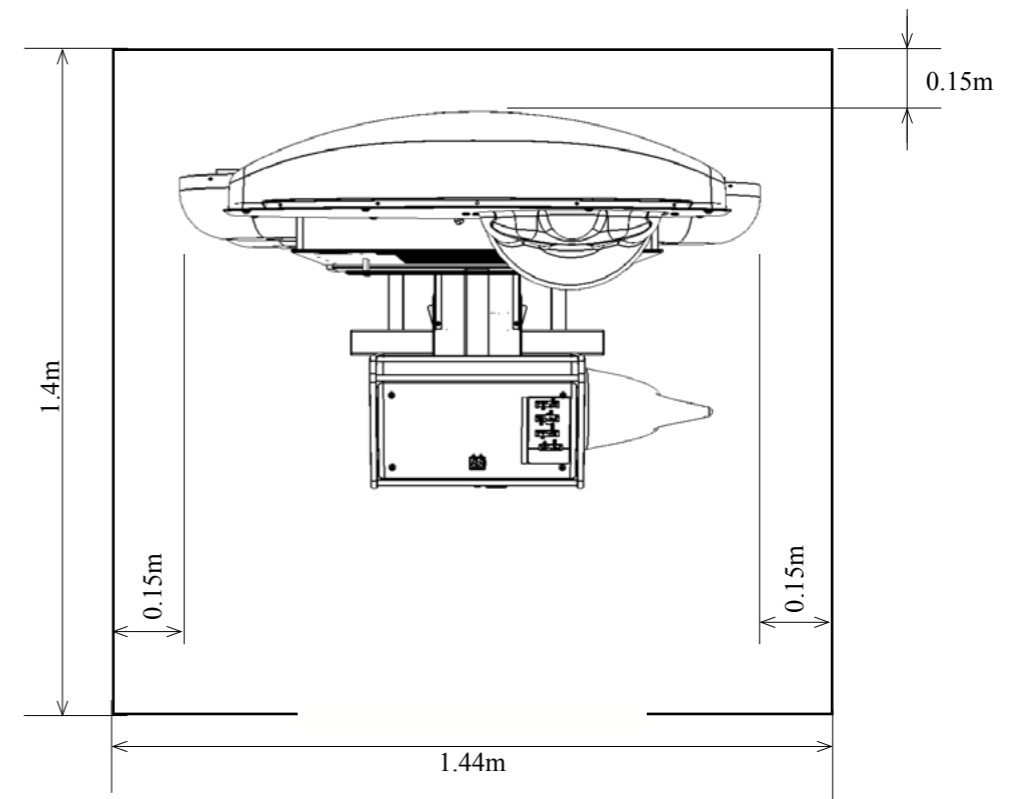

STOP IMPORTANT

To install this product, the entrance must be at least 0.85m in width and 2.73 m in height.

Do not attempt to push/pull the machines whilst holding onto the Controller or Assy Billboard. This may result in part damage and or personal injury.

2 PRECAUTIONS REGARDING INSTALLATION LOCATION

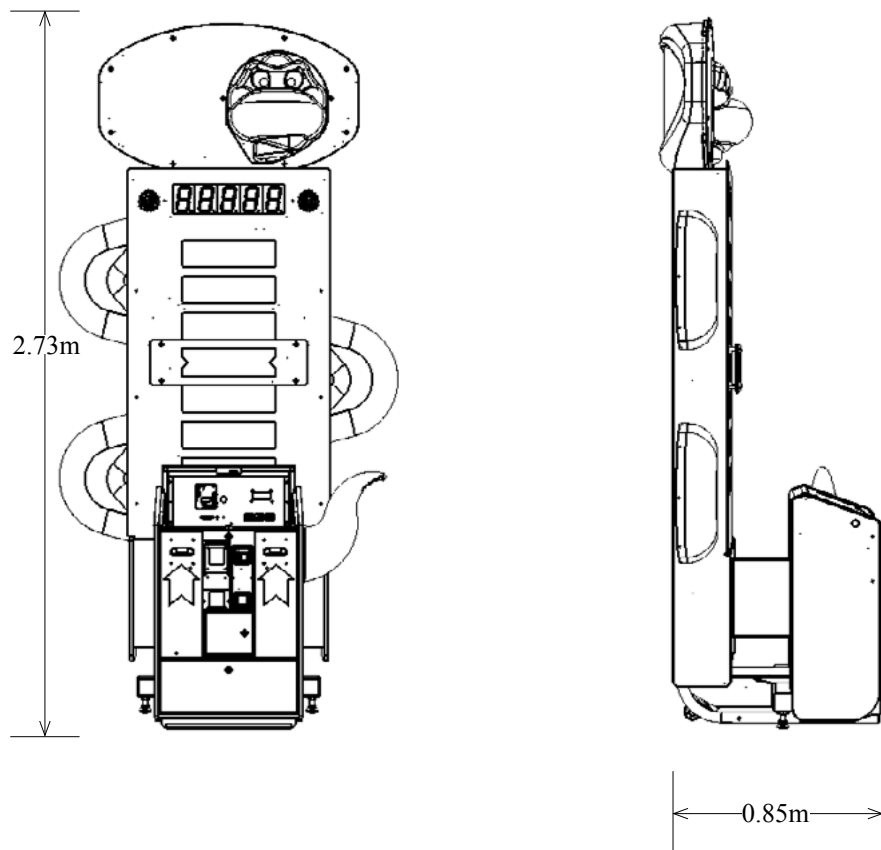

3 PRECAUTIONS REGARDING OPERATION

To avoid injury and trouble, be sure to pay attention to the behavior of visitors and players.

WARNING

In order to avoid accidents, check the following before starting the operation:

- To ensure maximum safety for the players and the customers, ensure that where the product is operated has sufficient lighting to allow any warnings to be read. Operation under insufficient lighting can cause bodily contact with each other, hitting accident, and/or trouble between customers.
- It is suggested to ensure a space allowing the players who feel sick while playing the game to take a rest.
- Check if all of the adjusters are in contact with the surface. If they are not, the Cabinet can move and cause an accident.
- Do not put any heavy item on this product. Items, if placed on this product may fall and cause injury to the player / observer.
- Do not climb on the product. Climbing on the product can cause falling down accidents. To check the top portion of the product, use a step ladder.
- To avoid electric shock, check that all doors and covers are in place and in good condition
- To avoid electric shock, short circuit and or parts damage, do not put the following items on or in the periphery of the product. Flower vases, flowerpots, cups, water tanks, cosmetics, and receptacles/containers/ vessels containing chemicals or water.

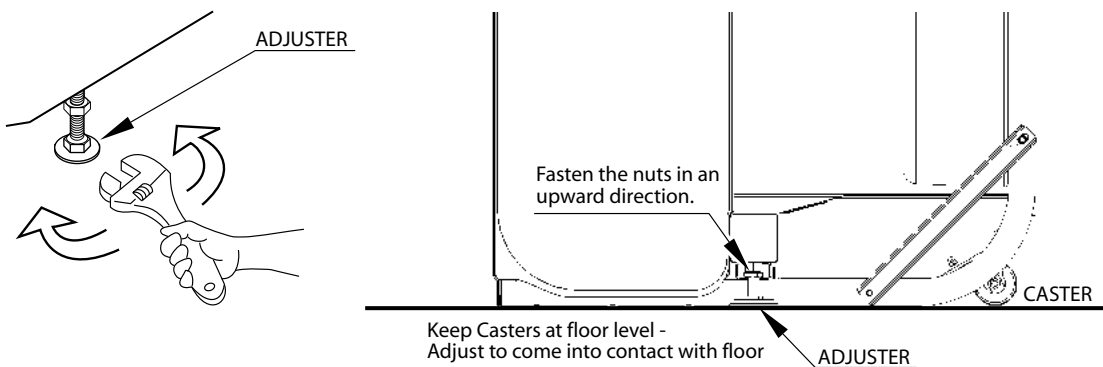

⚠ WARNING

- To avoid electric shock, ensure that all covers and panels are undamaged and fitted. Do not operate with covers removed.
- To avoid electric shock, short circuit and/or parts damage, do not put the following items on or in the periphery of the product.
- Flower vases, flowerpots, cups, water tanks, cosmetics, and receptacles/containers/vessels containing chemicals and water.

⚠ CAUTION

- To avoid injury, be sure to provide sufficient space by considering the potentially crowded situation at the installation location. Insufficient installation space can cause making bodily contact with each other, hitting accidents, and/or trouble between customers.
- Everyday when cleaning the Controllers, inspect the controllers and make sure that there are no cracks in the surface, and that the fastening screws are not loose. If the game is played with cracks or loose screws, it can cause injuries to the player.

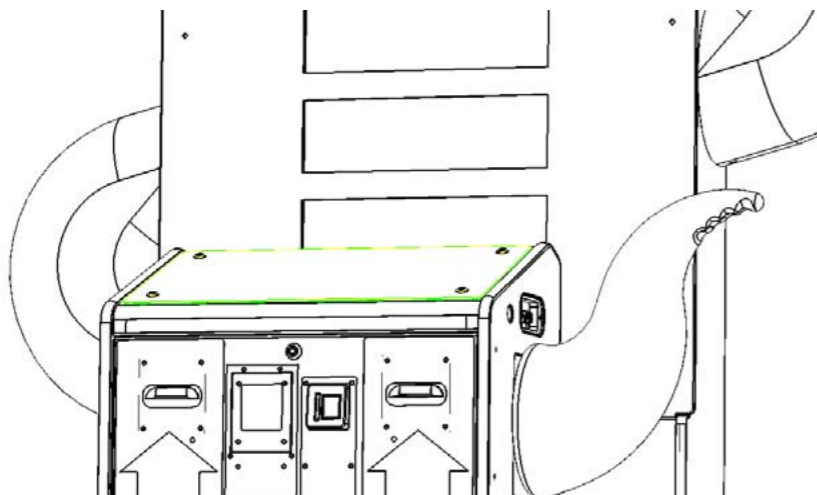

- It is recommended that wet towels (paper towels) be provided.

DURING OPERATION (PAYING ATTENTION TO CUSTOMERS)

To avoid injury and trouble, be sure to constantly give careful attention to the behavior and manner of the visitors and players.

⚠ WARNING

- For safety reasons, do not allow any of the following people to play the game.
- Those who have high blood pressure or a heart problem.
- Those who have experienced muscle convulsion or loss of consciousness when playing video games, etc.
- Those who have neck or spinal cord problems.
- Those who are intoxicated or under the influence of drugs.
- Pregnant women.
- Those who are not in good health.
- Those who do not follow the attendant's instructions.
- Those who cannot grasp the Control Unit securely because of immobility in fingers, hands or arms.
- Persons who disregard the product's warning displays.
- This product is intended for a single player only. Having two or more persons simultaneously playing this product can result to injury to the player and possible damage to the product.
- Even players who have never been adversely affected by light stimulus might experience dizziness or headache depending on their physical condition when playing the game.
- Small children are especially likely to experience these symptoms. Caution guardians of small children to keep watch on their children during play.
- Instruct those who feel sick during play to have a medical examination.
- To avoid injury from falls and electric shocks due to spilled drinks, instruct the player not to place heavy items or drinks on the product.
- To avoid electric shocks and short circuits, do not allow customers to put hands and fingers or extraneous matter in the openings of the product or small openings in or around the doors.
- To avoid falls and resulting injury, immediately stop the customer from leaning against or climbing on the product, etc.
- To avoid electric shock and short circuit, do not allow customers to unplug the power plug without a justifiable reason.
- Instruct the guardians of small children to keep an eye on their children.
- Children cannot sense danger. Allowing small children to get near a player who is playing the game could result in the children being bumped, struck or knocked down.

5 ACCESSORIES

Confirm that the accessories listed in the table below are present when setting up the product. Accessories marked “Spare” in the note column are consumable items but included as spares.

440-CS0186UK
Sticker C Epilepsy Multi (1)



DESCRIPTION: OWNER'S MANUAL
Part No. (Qty.): 420-00XXUK(1)

Parts not labeled with part numbers are as yet unregistered or cannot be registered. Be sure to handle all parts with care, as some parts are not available for purchase separately.

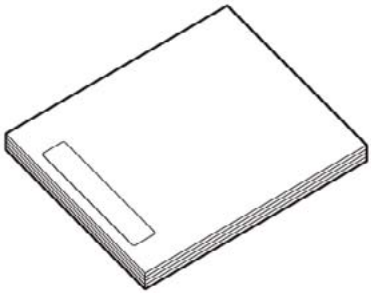

KEY
(2)

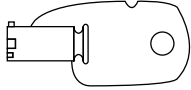

For the cashbox door
(Located inside the coin chute door at time of shipment)

KEY MASTER
220-5575-01UK (4)
For operating/closing the doors

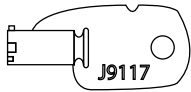

POWER CORD
LM1227 (1) <UK>
LM1246 (1) <EU>
or
LM1226 (1) <US>

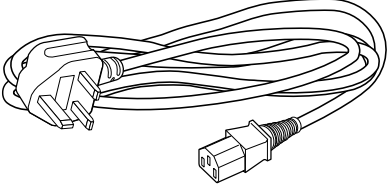

For installation. See chapter 6.

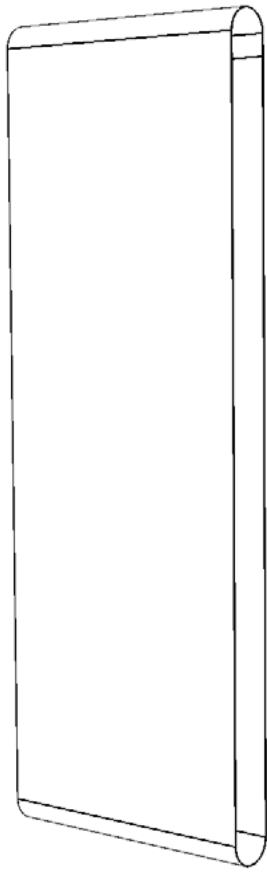

FEATURE BAND (2)

SL-1201-01UK - FEATURE BAND £2/€2/\$2

SL-1201-03UK - FEATURE BAND .50p/.50¢

For differnt prize values

6 ASSEMBLY AND INSTALLATION

WARNING

- Perform assembly work by following the procedure herein stated. Failure to comply with the instructions can cause electric shock.
- Perform assembly as per this manual. Since this is a complex machine, incorrect assembling can cause an electric shock, machine damage and/or improper functioning as per specified performance.
- When assembling, more than one person is required. Depending on the assembly work, there are some cases in which working by one person alone can cause personal injury or parts damage.
- Ensure that connectors are properly connected. Improper connections can cause electric shock.
- Be careful not to damage the wires. Damaged wires may cause electric shock or short circuit or present a risk of fire.
- Do not unnecessarily push the display screen.
- This work should be carried out by site maintenance personnel or other qualified professionals. Work performed by non-technical personnel can cause a severe accident such as electric shock. Failing to comply with this instruction can cause a severe accident such as electric shock to the player during operation. If no one with proper technological expertise is available, request service from the office indicated in this document or the point of purchase so as to ensure safety.
- Provide sufficient space so that assembling can be performed. Performing work in places with narrow space or low ceiling may cause an accident and assembly work to be difficult.
- To perform work safely and avoid serious accident such as the cabinet falling down, do not perform work in places where step-like grade differences, a ditch, or slope exist.
- This product does not use any connectors other than those connected to and used by the game board when it leaves the factory. Do not needlessly connect wires to unused connectors. This could lead to overheating, generation of smoke and burn related injuries.

CAUTION

- Handle molded parts with care. Excessive weight or pressure may cause them to break and the broken pieces may cause injury.
- To perform the operation safely and accurately you must use a safe, steady footstool or stepladder. Working without this may lead to a fall and possible injury.

6-1 INSTALLING THE CABINET

CAUTION

- Billboard weighs approximately 10kg once assembled. Have at least 2 people during this operation. Working alone could result in personal injuries, etc.
- To perform work safely and securely, be sure to prepare a step which is in a safe and stable condition. Performing work without using a step may lead to injury of damage to components.

Tools required for installation

Step or Step Ladder

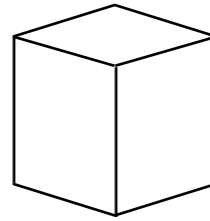

M8 Socket wrench or Spanner
- Attaching Billboard



Allen Key nos 4, 5 and 6 (M5) (M6) (M8)
- Attaching Billboard Panel to Assy Billboard.



Adjustable Spanner / Wrenck
- Adjust Leg Levellers



Required fixings and where to find them.

Fixings required for Billboard Installation.

These fixings are located within their respective fixing points within the cabinet.



030-000830-SB M8x30 BLT W/S BLK (4)

These fixings are located within the cashbox



020-000612-0C M6X12 SKT CAP CRM (2)

These fixings are located within their respective fixing points within the cabinet.

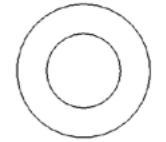

068-852216-0B M8 WSHR 22OD FLT BLK (4)

Fixings required for Snake Body installation (located within the Snake Body segments)

These fixings are located within their respective fixing points within the cabinet.



030-000635-S M6x35 BLT W/S PAS (9)

6-1-1 ASSEMBLING THE BILLBOARD

1 Identify parts required for installation. Remove the Rear Cover (Back Door)

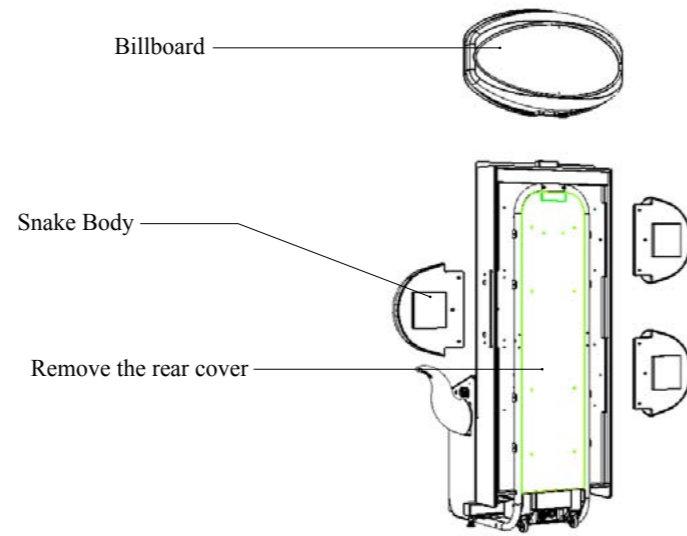

2 Remove the (4) M8x30 BLT BLK, (2) from the rear of the cabinet whilst holding onto the Billboard Bracket to prevent it from falling, and (2) from the inside ceiling of the cabinet near the Billboard Bracket recess.

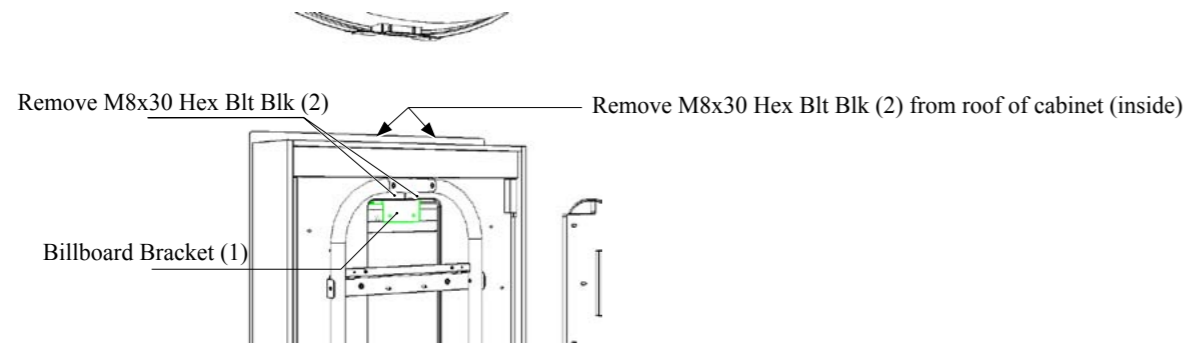

3 Lift the Billboard Bracket into position and refix using the same fixing.

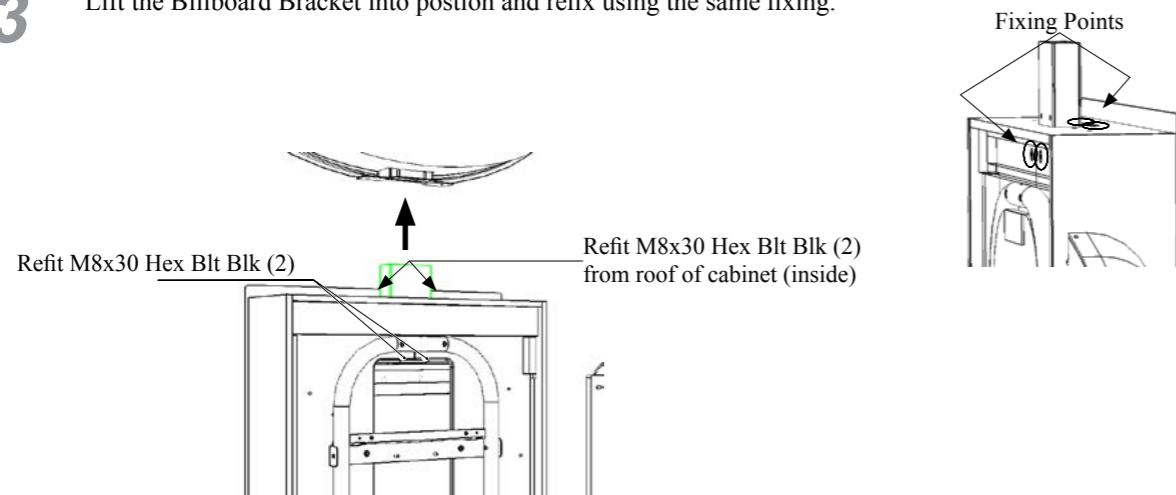

CAUTION

- Billboard weighs approximately 10kg once assembled. Have at least 2 people during this operation. Working alone could result in personal injuries, etc.
- To perform work safely and securely, be sure to prepare a step which is in a safe and stable condition. Performing work without using a step may lead to injury of damage to components.

4 Using (2) people, carefully lower the Billboard (taking care not to trap wires) over the Billboard Bracket and secure into place.

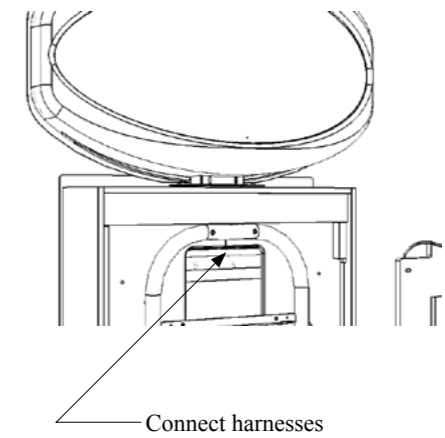
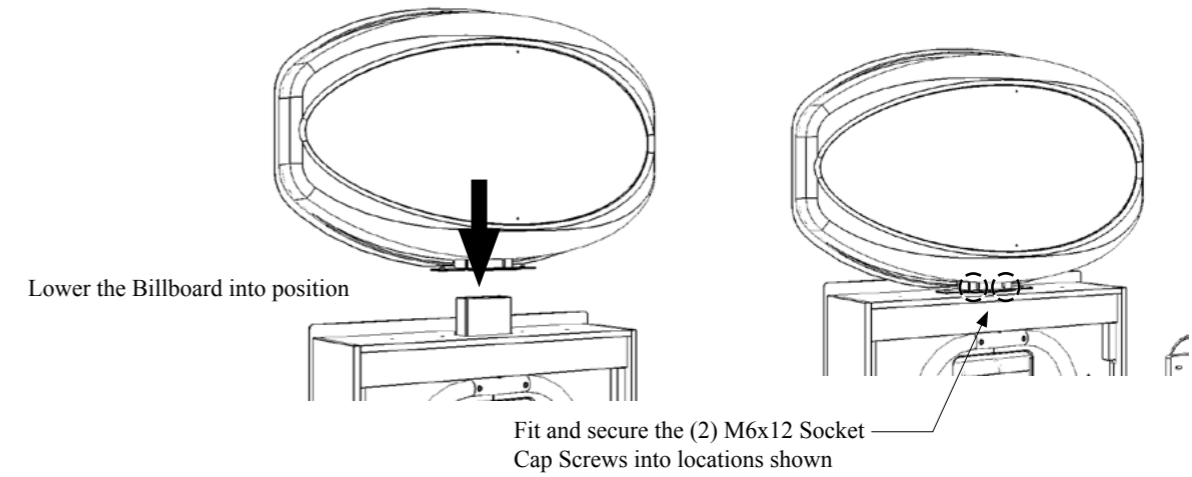

6-1-2 FITTING THE SNAKE BODY SEGMENTS

- 1 Remove the (6) M6x35 Hex Blt fixings from the sides of the cabinet where the Snake Body sections are to be fitted.

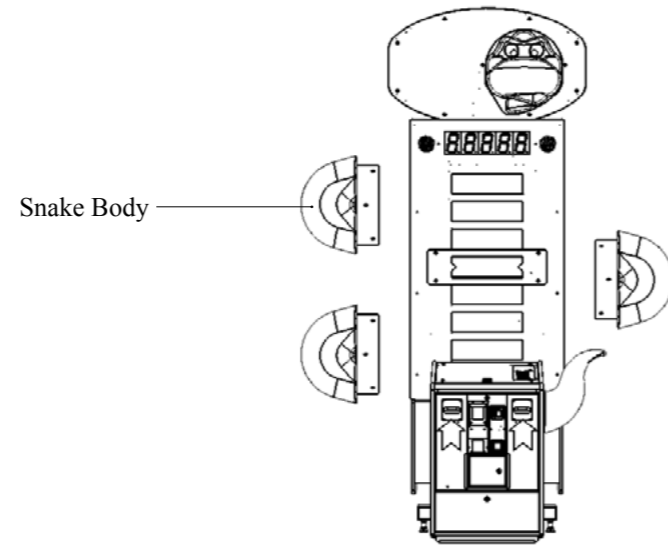

- 2 Slide each section into the designated slot and fix with (3 each) M6x35 Hex Blts removed from above instruction.

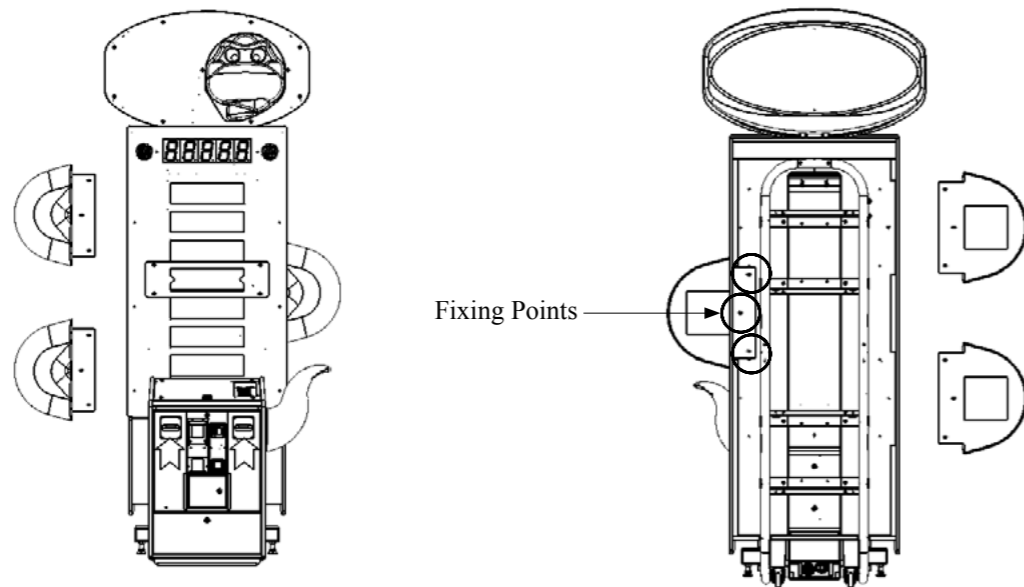

- 3 Once all sections have been fitted into place, make connections to each section from within the cabinet.

6-1-3 INSTALLING TICKETS

This game comes with (2) ticket units installed.. The purpose of these 2 units is so that the game can operate with twice the amount of tickets as a game with only a single unit. The ticket operation is such that when one unit dispenses its final ticket the remainder of that win will be paid to the player via the second ticket unit. The second ticket unit will continue to operated and pay tickets to the customer until the first unit is refilled.

- 1 Ensure the machine is powered off
- 2 Open the Console cabinet lid to access the ticket units and ticket holders.

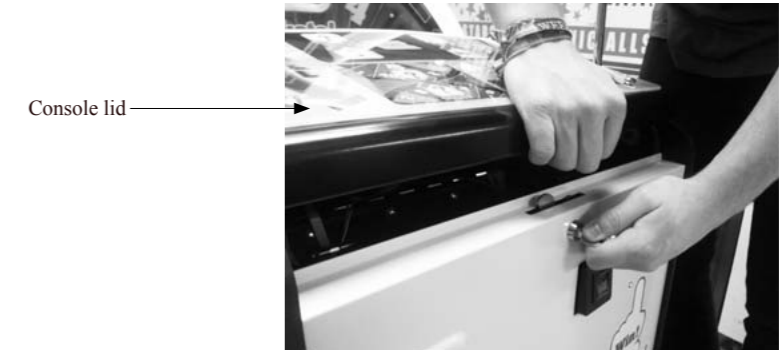

- 3 Locate the ticket unit and remove the ticket guide.

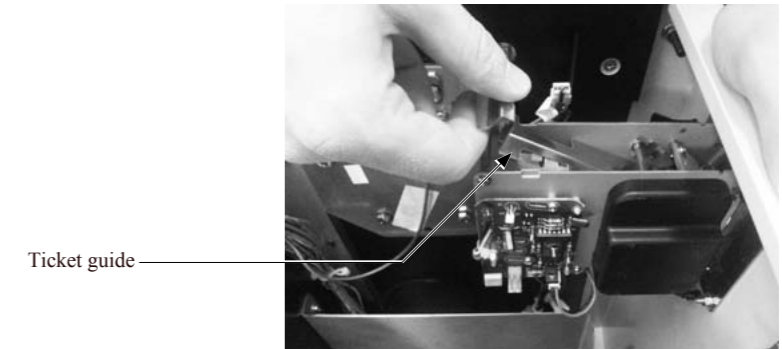

- 4 Using your index finger, lift the roller bar and lock it into the upper position.

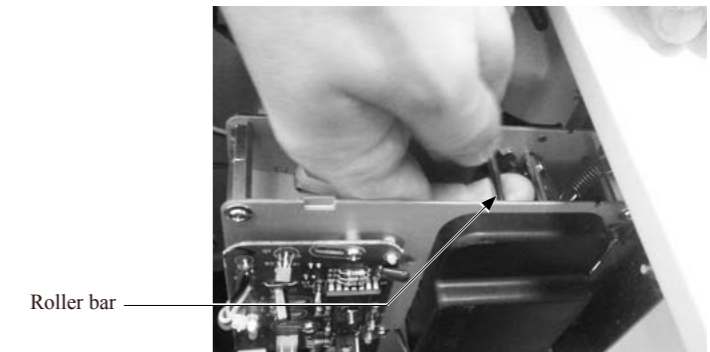

- 5 Feed the tickets into the ticket holder ensuring that the ticket passes through the guides.

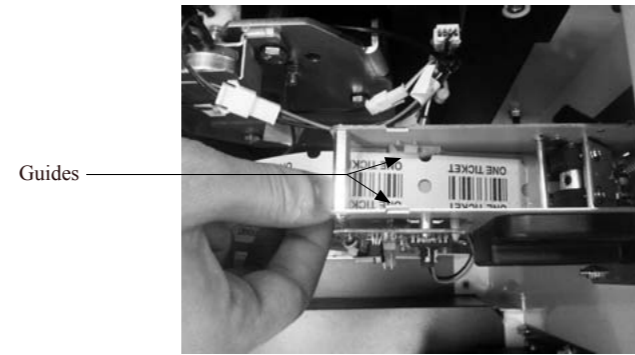

- 6 Feed the tickets into the ticket holder ensuring that the ticket passes underneath the ticket rollers.

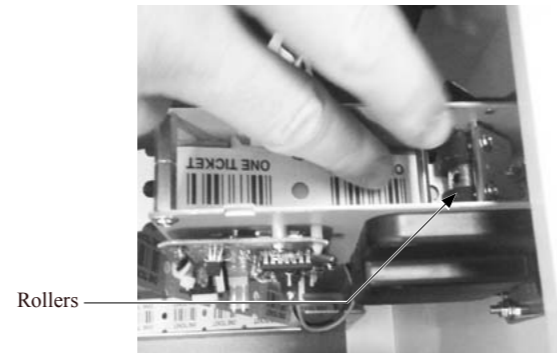

- 7 Lower the roller bar and refit the ticket guide, making sure that the guide locks onto the upper bar.

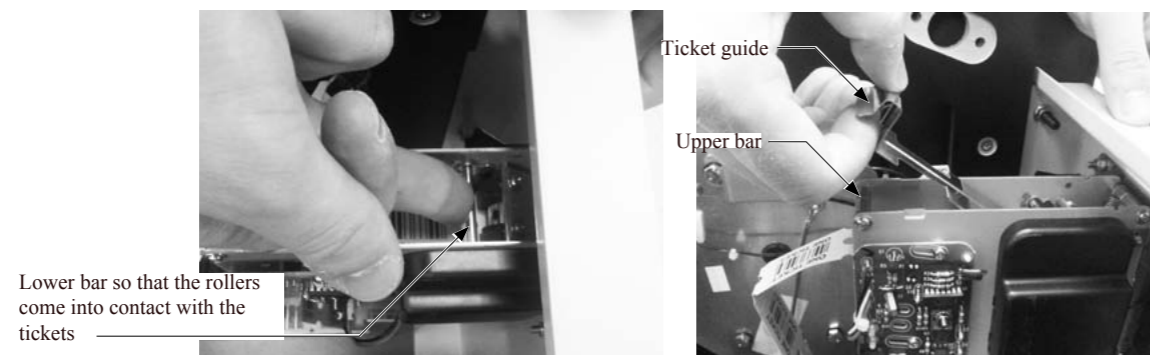

- 8 Apply power to the cabinet and wait for the machine to initialise.

- 9 Press the ticket feed button to feed a number of tickets out through the front panel checking for ticket jam in the process.

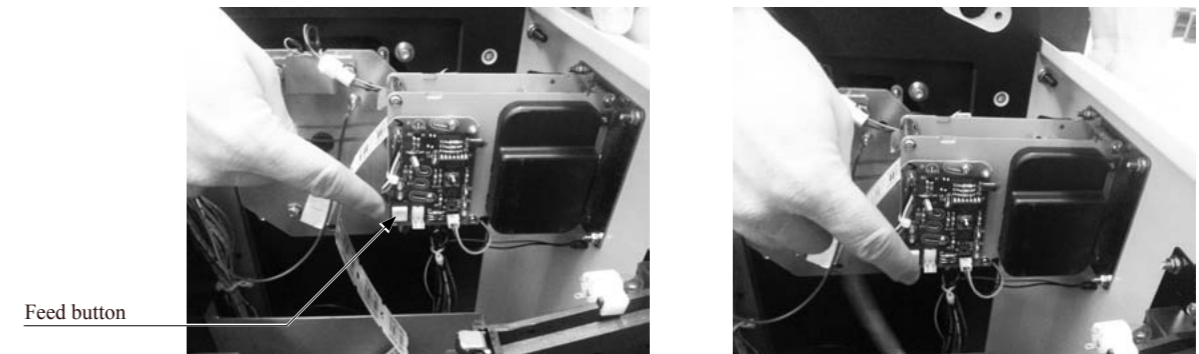

- 10 Remove any excess tickets.



Repeat the operation to install tickets into the second ticket unit..

6-2 FIXATION TO SITE

WARNING

- Make sure that all the adjusters contact the floor. Otherwise the cabinet could move, causing an accident.
- Provide a ventilation space at least 15cm wide behind the cabinet. There are ventilation holes on the back of the cabinet. Do not block the ventilation holes. Doing so could trap heat inside resulting in fire. It could also result in equipment damage or cause parts to become exhausted prematurely.

The product is equipped with 2 casters and 2 adjusters.

When installation position / site has been determined, have the adjusters come in direct contact with the floor. Adjust the adjusters to eliminate any movement in the cabinet.

1 Move the product to the installation site.

2 Bring the adjusters into direct contact with the floor. Use a wrench to align the height of the adjusters until the cabinet is perfectly level.

3 After setting, turn adjuster nuts upwards to tighten them and secure adjuster heights.

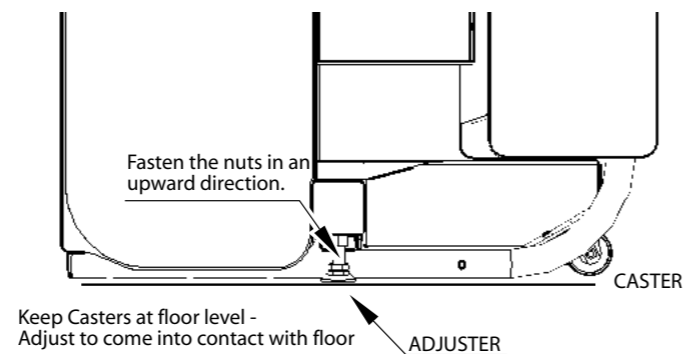
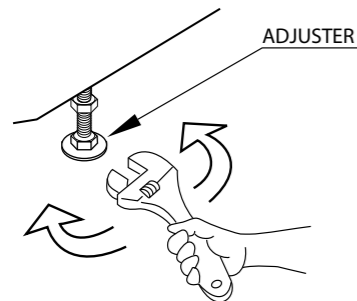
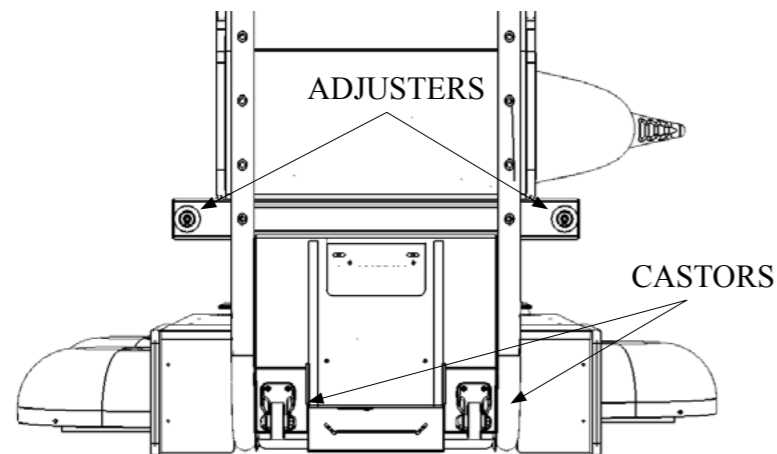

WARNING

- Provide a ventilation space at least 15cm wide behind the cabinet. There are ventilation holes on the back of the cabinet. Do not block the ventilation holes. Doing so could trap heat inside resulting in fire. It could also result in equipment damage or cause parts to become exhausted prematurely.

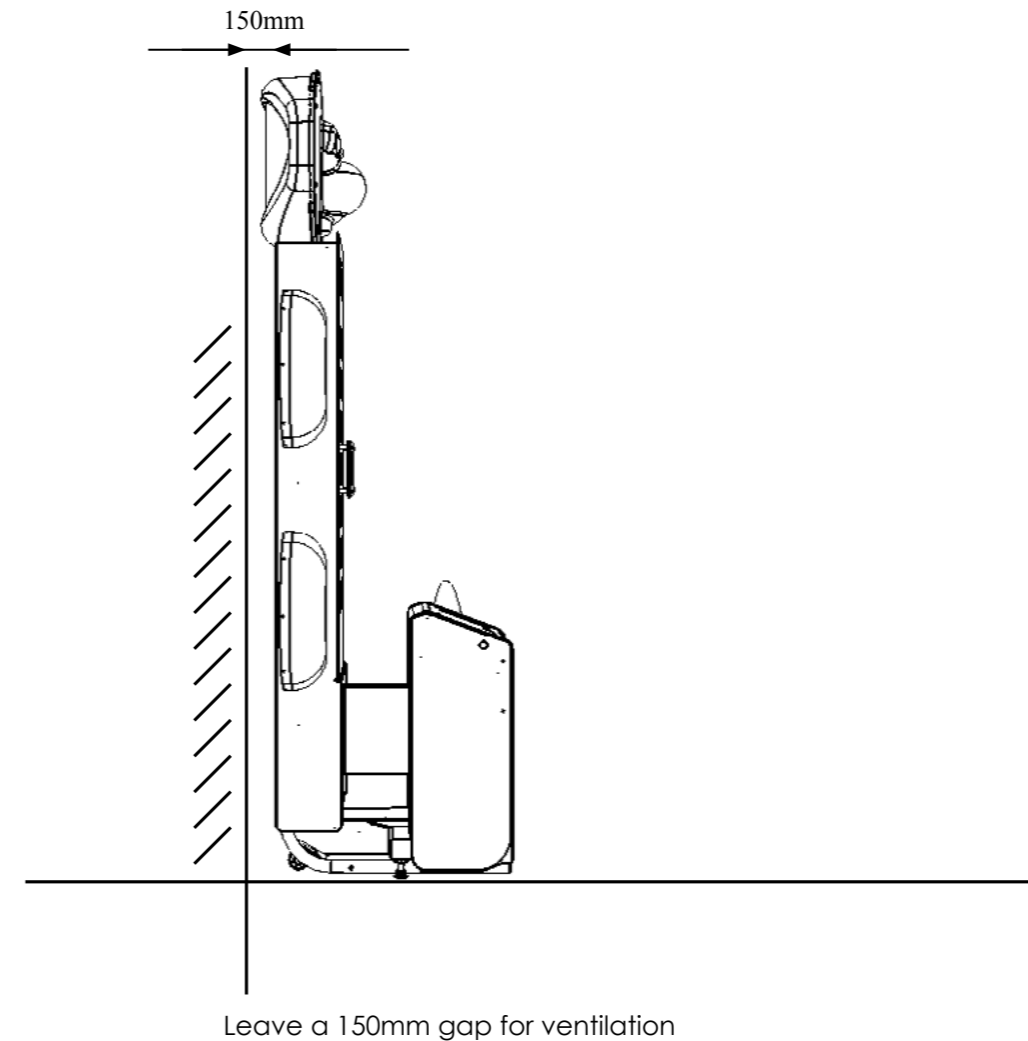

6-3 POWER SUPPLY AND OTHER CONNECTIONS

⚠ WARNING

- Use the power supply equipped with an earth leakage breaker. Use of power supply without such a breaker could result in fire if there is a current leakage.
- Have available a securely grounded indoor ground terminal. Without proper grounding, customers could be electrocuted and product operations might not always be stable.
- Do not expose the power cord or ground wire. If these are exposed, customers could stumble over them, for instance, and easily damage them. Additionally, if these lines are damaged, there could be a risk of electrical shock or short circuit. Set these lines at locations where they will not interfere with customer traffic, or attach covers to them.
- After laying out the power cord on the floor, be sure to always protect it. If the power cord is left exposed, it can easily be damaged, resulting in electrical shock.

- 1 Confirm that the main switch is at OFF.

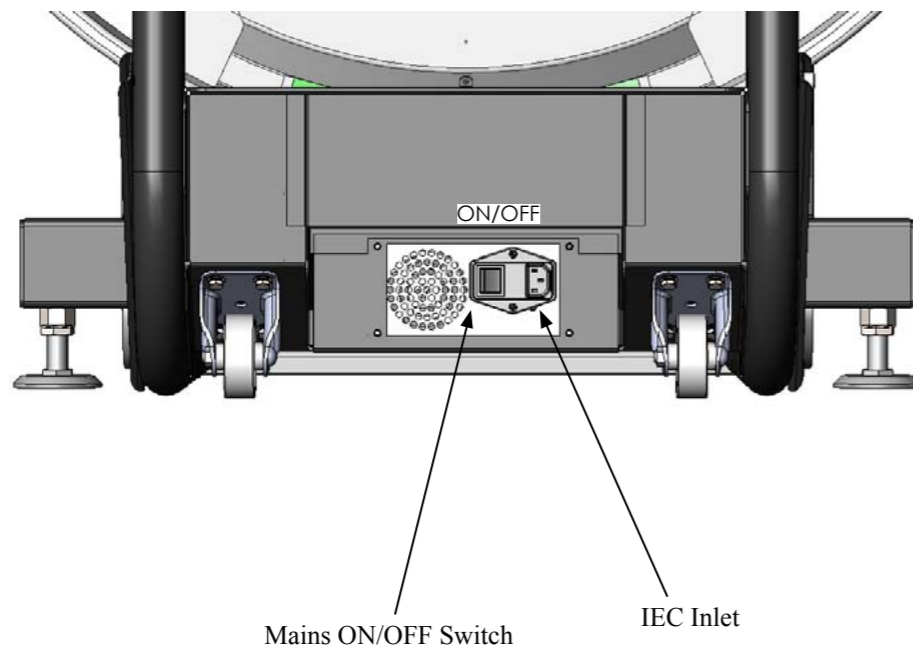

- 2 Fully insert the power cord connector on the side opposite the power plug into the AC unit IEC inlet. Insert the power cord plug into the outlet.

- 3 The power cord is laid out indoors. Protect the power cord by attaching wire cover to it.

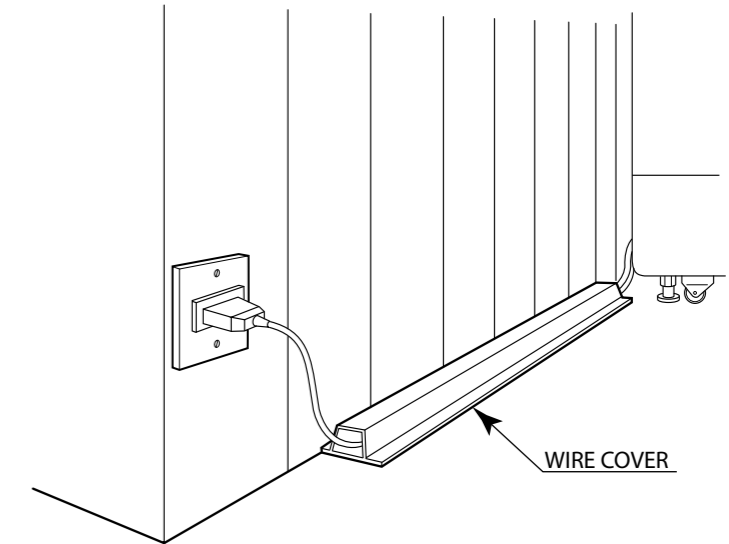

6-4 TURNING ON THE POWER

Set the main switch of the AC unit to ON and engage the power.

When you turn on the power, both feature wheel will spin slowly in a downward direction before coming to rest.

The lighting effects around the feature wheel and ladder will illuminate.

The Billboard light will illuminate and the feature wheel will come to a standstill.

Start up sounds are output from the speakers on the front of the cabinet.

The Game will now be playable.

COMPONENTS WHICH CHANGE STATE WHEN POWER IS APPLIED

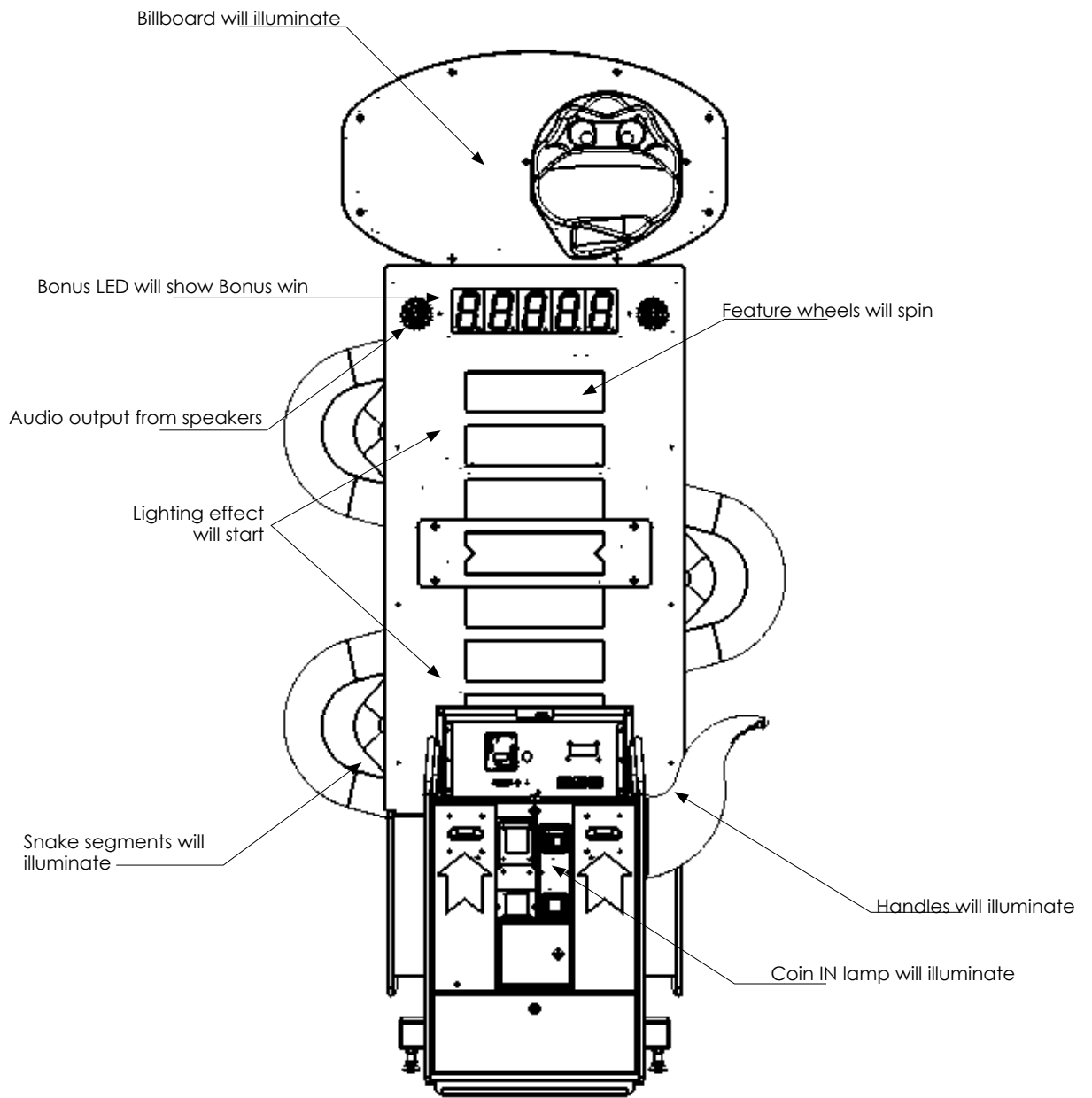

7 PRECAUTIONS WHEN MOVING THE MACHINE

WARNING

- Always disconnect the power cable before moving the product. If it is moved with the power cable connected, the cable could be damaged, causing fire or electric shock.
- To move the unit over the floor, pull in the adjusters and have the casters contact the floor. While moving the unit, be careful that the casters do not roll over the power cord or the ground wire. If cord or wire is damaged, there could be electrical shocks and/or short circuits.
- When crossing a sloped or stepped area, always have the machine travel lengthways. Travelling with the machine in a sideways position could result in the machine falling over onto its side. Always use a minimum of two people working together plus lifting apparatus to accommodate sloped areas or stairs.
- To lift up the cabinet, hold it at the bottom at the designated lifting points. If you hold it anywhere else, the weight of the cabinet could cause damage to parts or attachments, resulting in injury.
- Do not push the cabinet from the side when moving. Pushing from the side as it may result in the cabinet falling over.

IMPORTANT

- When moving the cabinet, do not grip or push the Controllers. Doing so could deform or damage the part.
- If moving through a door or place with a low ceiling such as an elevator, you should take apart the billboard and billboard plate.

Detailed instructions for removing the Assy Billboard and Billboard Plate can be found in Chapter 6 of this manual. Please follow these instruction in reverse order for removal.

7-1 PRECAUTIONS WHEN MOVING FROM SITE

STOP IMPORTANT

• When moving the cabinet into and out of buildings, be sure to remove the Billboard Assy and the 3 snake segments. Failure to remove all these items may result in personal injury, damage to the cabinet or damage to property.

Remove the Billboard and Billboard Plate when transporting the machine in and out of buildings or when passing through areas with low ceilings.

Remove the (3) snake side segments

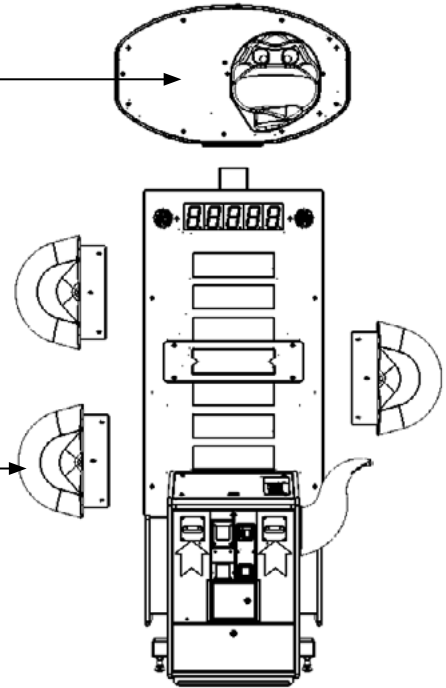

STOP IMPORTANT

When positioning the cabinet within the location it is possible to tilt the machine back on its casters to move over short distances. Do not attempt to move the cabinet in this manner when the Billboard is attached or attempt to move over long distances as this may damage the product or cause personel injury.

It is possible to position the cabinet within a location by tilting

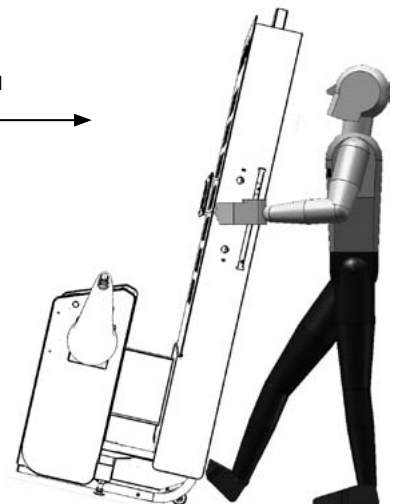

SNAKES & LADDERS GAMEPLAY

CREDIT ENTRY

Credit will only be given once sufficient coins have been inserted.

The Game will not register or otherwise acknowledge any part credits

As soon as the Credit Value changes, an AUDIO SFX is played.

Multiple credits will give repeated AUDIO SFX, although this SFX cannot be interrupted

Attract stop

If credit changes from zero, all attract lighting and audio will stop immediately

Super Win display will show current super bonus value.

The Ladder rungs will fill to the previous position achieved.

The Snakes Body will scroll from the top to the bottom and back up again.

The Control Panel 'PULL' Arrow will flash GRN. Then light each segment in turn from the top to the bottom to indicate the direction the player must pull the lever. This sequence is repeated until the player pulls the lever or the software times out (See below) and starts the game automatically.

Win-line illumination turns to OFF

Audio loop played while waiting for lever to be pulled.

LEVER PULL BACK

Credit Usage

A Credit will be deemed to be used once the Player moves the lever, or a Lever Timeout occurs (see below)

The Credit Value registered on the Credit Display will be decremented by 1 credit

Lever Pull Timeout

The player has 10 seconds in which to pull the lever.

If the lever is not pulled with the timeout period the current credit will be automatically played.

If the Lever has been pulled but not been released when the timeout period expires, the Lever will be deemed to have been released from the current position.

Lever Pull Increments

The Lever has 10 mechanical ratchet positions as it is pulled away from the cabinet.

The full mechanical travel of the Lever will be determined during calibration and will be split into 10 calibrated lever positions (for each 10% of maximum Lever travel)

As it is not possible to match ratchet clicks to the calibration data, software Lever increments may not correspond to mechanical ratchet clicks.

LEVER RELEASE

- Release Strength

The ultimate Level Position used to determine launch speed of the feature band will be the MAXIMUM position achieved before the Lever is deemed to have been released. This means that if a Player pulls a Lever to its MAXIMUM position, then moves it to the halfway point, then releases, then the MAXIMUM position will be used

The Credit Value registered on the Credit Display will be decremented by 1 credit

Release Point

The Lever release point is considered to be when the Lever returns to within a nominal 5% of the rest position

Tracker Spin

The Tracker spin trigger point will be deemed to have started as soon as the handle is pulled. The Tracker will spin in a downwards direction.

The speed of the tracker will be determined by the amount the lever is pulled back. An audio loop will accompany the spin cycle.

The current Ladder rung position shall remain static until an increment or decrement is determined at the end of the game.

Tracker Spin Stop

The appropriate Tracker symbol resting in the Win Line remains lit while the remaining 6 are extinguished.

Once the Tracker stops the Numeric value on the Win Line will be shown on the Super Win display..

Bonus Feature

Each Tracker numeric is accompanied by either an *Up the Ladder* overlay (printed to the left or right hand side of the numeric) symbol or a *Down The Ladder* overlay (printed to the right hand side of the numeric) symbol.

If the bonus symbol is *Up the Ladder*, the next rung up is awarded / lit and the corresponding S U P E R W I N letter is lit. This is accompanied by an audio sting.

The newly awarded rung plus the corresponding S U P E R W I N letter will flash. All rungs below remain statically lit.

Once the new rung position is awarded the TICKET WIN is paid out. The Value of the win is displayed on the SUPER WIN display and counts down as the tickets are dispensed.

9 EXPLANATION OF TEST AND DATA DISPLAY

Perform tests and data checks periodically by manipulating the TEST Button and SERVICE Button in the cabinet. Follow the instructions in this chapter to conduct checks when the game machine is first installed, when money is being collected, or when the game machine does not operate properly.

Shown overleaf are the tests and screens to be used for different problems.

STOP IMPORTANT

- The details of changes to test mode settings are saved when you exit from TEST MODE by selecting EXIT from the system test mode menu. Be careful because if the power is turned off before that point, changes to the settings will be lost.
- Use with the specified settings. If settings other than those specified are used, inappropriate operations or malfunction may occur.

STOP IMPORTANT

- Adjust the sound to the optimum volume, taking into consideration the environmental requirements of the installation location.

9-1 SWITCH UNIT AND COIN METER.

The SWITCH UNIT and COUNTERS are housed within the COINTOWER. To access these controls you will need to open the COIN door, the switches and counters can be found directly on the rear face of the Tower.

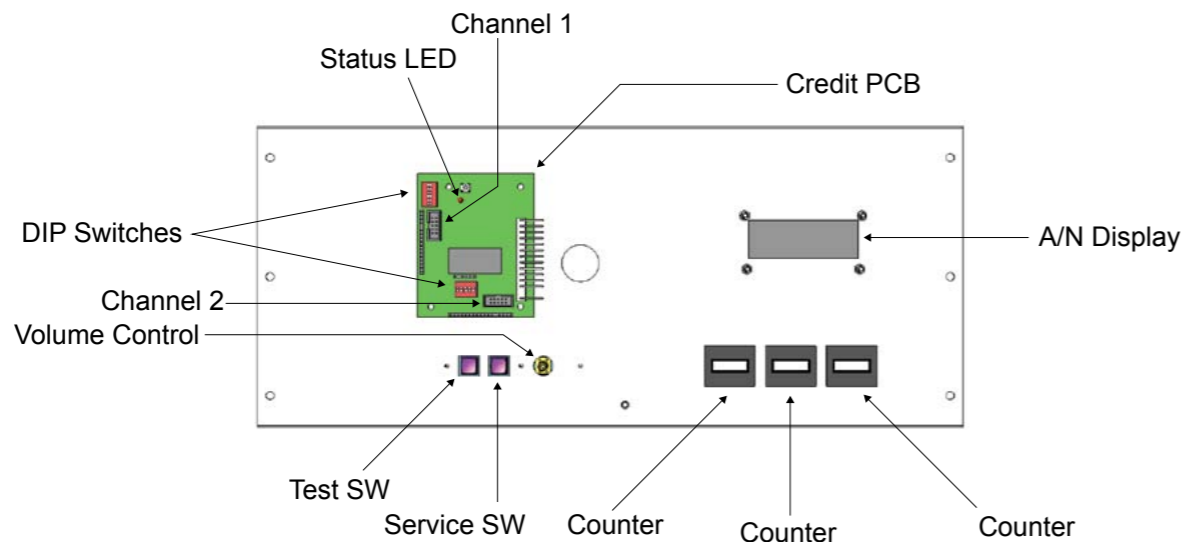

| DEVICE | FUNCTION |
|-----------------|---|
| TEST BUTTON | Press to enter TEST MODE - Also used to enter choices selected within TEST MODE |
| SERVICE BUTTON | Press for SERVICE CREDIT - Also used to scroll through TEST MENUs |
| COIN IN COUNTER | Counts inserted coins (£0.10 or \$0.10 = 1 count) |
| VOLUME CONTROL | Adjusts audio level |

9-2 TEST MENU

STOP IMPORTANT

The details of changes to Test Mode settings are saved when you exit from each Test Mode by selecting EXIT. Be careful because if the power is turned off before that point, changes to the settings will be lost.

SYSTEM TEST MODE can be used to check the information or the operation of UNCOCH (RedOne), adjust Gameplay settings, and perform coin/credit settings.

- 1 Press the TEST Button after powering on the unit to display the following TEST MENU.

For further details, see the UNCOCH (RedOne) section in this service manual.

TEST MODE

Factory default settings are in BOLD configuration and coin configuration changes can be made within TEST MODE.

TEST MENU

Press the TEST button to open the TEST MENU.

The following options are available from the TEST MENU.

| | |
|---------------|---|
| SYSTEM INFO | General Information and version numbers for software and hardware. |
| LIGHTING TEST | Test functions for the lighting of the cabinet |
| DISPLAY TEST | Test functions for the 7 segment LED and Starburst displays |
| INPUT TEST | Test functions for switches, buttons, levers, ticket opto, and coin lines |
| OUTPUT TEST | Test functions for ticket vend and coin and ticket meters |
| CALIBRATION | Calibration functions for Lever Pull and Wheels |
| AUDIO SETTING | Set volume levels for attract and in game audio |
| GAME SETTINGS | Set Game mode, price of play, ticket value and percentage payout |
| BOOKKEEPING | View game and ticket data and clear bookkeeping |
| SET DATE/TIME | Set date and time |
| EXIT | Exit the Test Menu to return to the game |

Press the SERVICE button to move to the next Test menu option. Press TEST button to enter the selected item.

The text TEST MODE will be displayed on LINE 1 of the 2x16 LCD screen. The current Test Function will be displayed on LINE 2 of the screen. For Example:

TEST MENU
1.SYSTEM INFO

SYSTEM INFORMATION

Select SYSTEM INFO from the TEST MENU to display the SYSTEM INFORMATION menu.

TEST MENU
1.SYSTEM INFO

The SYSTEM INFORMATION test displays general information and version numbers for system hardware and software.

Game Name and Version Info Snakes & Ladders
v0.1.0070

Hardware and Serial Info BOOTLOADER=v1.0
SERIAL#=0101fe04

LIGHTING TEST

Select LIGHTING TEST from the TEST MENU to display the LIGHTING TEST menu.

TEST MENU
2.LIGHTING TEST

The LIGHTING TEST is used to test the functionality of the lights on the cabinet. To implement the test, select a lighting test and press the Test button to turn on/off or cycle through the light(s).

ALL LEDS This will turn all lighting features for the cabinet on/off.

LIGHTING TEST
ALL LEDS

Pressing the TEST button will turn all LEDs on.

ALL LEDS
ON

Press the SERVICE button to stop the test and return to LIGHTING TEST menu.

LED STEP DIRECT This will test the individual LEDs of the Ladder Assy and Rolling Road Assy.

LIGHTING TEST
LED STEP DIRECT

Pressing the TEST button will cycle through the colours.

LED STEP DIRECT
DIR:000 WHITE

Press the SERVICE button to stop the test and return to the LIGHTING TEST menu.

LED STEP MUX This test will cycle through (in order) the LEDs on the Snakes Body. These lights are used to illuminate the snakes body.

LIGHTING TEST
LED STEP MUX

Pressing the TEST button will cycle clockwise around the top wheel followed by the bottom wheel.

Press the SERVICE button to stop the test and return to the LIGHTING TEST menu.

LED STEP SERIAL This test will cycle through (in order) the LEDs on the control panel and win line.

LIGHTING TEST
LED STEP SERIAL

Press the SERVICE button to stop the test and return to the LIGHTING TEST menu.

EXIT LED TEST MENU. Press the TEST button to exit LIGHTING TEST and return to the TEST MENU.

DISPLAY TEST

Select DISPLAY TEST from the TEST MENU to display the DISPLAY TEST menu.

TEST MENU
3.DISPLAY TEST

The DISPLAY TEST is used to test the numeric displays. The first display is on the control panel and is used to show credits available. The second is at the top of the ladder and this shows wheel values and total tickets won.

ALL SEGMENTS This will test both the display in the ladder and on the control panel.

DISPLAY TEST
ALL SEGMENTS

IDENTIFY This will output 01 on control display and 234567 on the ladder display.

IDENTIFY
CR=01 SB=23456

SEGMENT STEP This will test each of the 7 segments and decimal place in sequence for both displays.

SEGMENT STEP
SEGMENT=A

EXIT DISPLAY TEST Press the TEST button to exit DISPLAY TEST and return to the TEST MENU.

INPUT TEST

Select INPUT TEST from the TEST MENU to display the INPUT TEST menu.

```
TEST MENU
4.INPUT TEST
```

The INPUT TEST contains test functions for the cabinet input devices, such as switches, buttons and levers.

LEVER INPUTS This test shows the input signals for the lever. Moving the lever will display the current input signal.

```
LEVER 0000
```

SWITCH INPUTS This test shows the current status of all SWITCH BANK1 positions. 0 indicates a switch is OFF, 1 indicates a switch is ON. Also displayed is the current status of the TEST and SERVICE buttons. Pressing the TEST or SERVICE buttons will change the status to ON.

```
DIL SW1-6 001000
TST OFF SRV OFF
```

PLEASE NOTE: To exit this test you must press and both TEST and SERVICE together.

OPTO INPUTS This test shows the current status of the track and ticket opto switches. When activated the status will change to ON.

```
TOP ON TKTL ON
BOT ON TKTR ON
```

EXIT INPUT TEST Press the TEST button to exit INPUT TEST and return to the TEST MENU.

OUTPUT TEST

Select OUTPUT TEST from the TEST MENU to display the OUTPUT TEST menu.

```
TEST MENU
5.OUTPUT TEST
```

This test is used to check all configured outputs from the IO board. This includes physical meters, ticket vends and stepper motor.

METER OUTPUTS This test will send a pulse to the game and ticket meters and increase their values by 1 unit. There is a test for each meter, press the SERVICE button to select which meter to test and press the TEST button to initiate.

```
METER OUTPUTS
TEST GAME METER
```

```
METER OUTPUTS
TEST TICKET METER
```

Select EXIT to return to the OUTPUT TEST menu.

TICKET OUTPUTS This will test the ticket vend, use the SERVICE button to select either the left or right ticket vend and press TEST to vend a single ticket.

```
TICKET OUTPUTS
LEFT TKT VEND
```

A message will be displayed on completion of the test.

```
TICKET OUTPUTS
VEND OK
```

Select EXIT to return to the OUTPUT TEST menu.

MOTOR OUTPUTS This will test the motor for the track. Press TEST button to select Track and initiate test.

```
MOTOR OUTPUTS
TEST TRACK
```

After selecting the track to test the screen will display the message TRACK SPINNING. During this test the TEST and SERVICE buttons are disabled and you must wait for the test to complete before making another selection. It is not possible to cancel the test.

```
MOTOR OUTPUTS
TRACK MOVING
```

Select EXIT to return to the OUTPUT TEST menu.

EXIT MENU. Press the TEST button to exit OUTPUT TEST and return to the TEST MENU.

CALIBRATION

Select CALIBRATION from the TEST MENU to display the CALIBRATION menu.

TEST MENU
6.CALIBRATION

This test is used to calibrate the lever and set the offset level for the track.

CALIBRATE LEVER This test will allow for the lever to be calibrated and ensure reliable game play.

CALIBRATION
CALIBRATE LEVER

When first selecting CALIBRATE LEVER an instruction will be displayed, PLEASE WAIT, during this time the levers are being unlocked. The next step requires the lever to be pulled and held at it's lowest position.

CALIBRATION
PULL BOTH LEVERS

Wait until instructed to release the levers. When the calibration is complete the message DONE! is displayed.

CALIBRATION
DONE!

SET TRACK OFFSET

EXIT CALIBRATION Press the TEST button to exit CALIBRATION and return to the TEST MENU.

AUDIO SETTINGS

Select AUDIO SETTINGS from the TEST MENU to display the AUDIO SETTINGS menu.

TEST MENU
7.AUDIO SETTINGS

This test is used to turn on/off the sound during attract, when the game has zero credit, and test the speakers performance.

AUDIO IN ATTRACT This will turn on/off sound during attract.

AUDIO SETTINGS
AUDIO IN ATTRACT

Pressing the TEST button will turn sound during attract on/off

AUDIO IN ATTRACT
SETTING: ON

Press the SERVICE button to return to the AUDIO SETTINGS menu.

AUDIO PLAY TEST This will play sample music to test that the speakers are working.

AUDIO SETTINGS
AUDIO PLAY TEST

Pressing the TEST button will turn the sample music on

AUDIO PLAY TEST
SETTING: ON

Press the SERVICE button to stop the test and return to AUDIO SETTINGS menu.

EXIT AUDIO TEST Press the TEST button to exit AUDIO SETTINGS and return to the TEST MENU.

GAME SETTINGS

Select GAME SETTINGS from the Test Menu screen to display the GAME SETTINGS menu.

TEST MENU
8.GAME SETTINGS

This test is used to change percentage payout, cost of play, ticket values and Super Bonus settings.

This menu is set out differently to previous menus. When entering GAME SETTINGS the option to change settings is display immediately. To change the values press the TEST button. To move to the next option press the SERVICE button.

SET PAY %AGE Options available: 20% to 80% (5% increments)

SET PAY %AGE
SETTING: 30%

SET COST OF PLAY Options available: 0.20, 0.25, 0.50, 1.00 and 2.00

SET COST OF PLAY
SETTING: 1.00

SET TICKET VALUE Options available: 0.01 to 0.10 (0.01 increments)

SET TICKET VALUE
SETTING: 0.01

SUPERBONUS TYPE Options available: FIXED and INCRMNT
 FIXED – The value is fixed at the value set in SUPERBONUS MAX
 INCRMNT – The Super bonus value will increment each game by the value specified in SUPERBONUS INC, up to the value specified in SUPERBONUS MAX.

SUPERBONUS TYPE
SETTING: FIXED

SUPERBONUS MAX Options available: 100 to 1000 (100 increments) 2000, 5000 and 9999

SUPERBONUS MAX
SETTING: 1000

This is the maximum value the Super Bonus will reach in any game type.

SUPERBONUS START Options available: 0, 10, 50, 100, 200, 500

SUPERBONUS START
SETTING: 100

Only used when the SUPERBONUS TYPE is set to INCRMNT. This value is the starting value of the Super Bonus.
 PLEASE NOTE: SUPERBONUS START cannot be higher than SUPERBONUS MAX.

SUPERBONUS INC Options available: 0.1, 0.25, 0.5, 1, 2, 3, 4, 5, 10

SUPERBONUS INC
SETTING: 1

Only used when the SUPERBONUS TYPE is set to INCRMNT. This is the value Super Bonus increments after each game.

SUPERBONUS FREQ Options available: LOW, NORMAL and HIGH

SUPERBONUS FREQ
SETTING: NORMAL

This function modifies the Super Bonus drop frequency by allocating more tickets to the Super Bonus each game.

EXIT SETTINGS Press the TEST button to exit GAME SETTINGS and return to the TEST MENU.

BOOKKEEPING

Select BOOKKEEPING from the Test Mode to display the BOOKKEEPING menu.

TEST MENU
9.BOOKKEEPING

This test is used to review statistical data from the system, and also clear all bookkeeping, tickets owed and unused service credits.

Press the SERVICE button to view the next BOOKKEEPING screen.

SCREEN 1 CREDITS Total number of COIN credits entered
 SERVICE Total number of SERVICE credits entered

CREDITS =0000050
SERVICE =0000001

SCREEN 2 GAMES Total number of games played
 TICKETS Total number of tickets paid out

GAMES =0000051
TICKETS =0001530

SCREEN 3 AIM PC Aiming percentage payout set in GAME SETTINGS
 ACTUAL PC Actual percentage payout achieved by the cabinet

AIM PC = 30%
ACTUAL PC= 30%

SCREEN 4 TRK TKT Total number of tickets paid out from the track
 SBNS TKT Total number of tickets paid out by winning Super Bonus

TRK TKT =0000530
SBNS TKT=0001000

SCREEN 5 AVRG TKT Average amount of tickets paid out per game
 BONUS 1 in The drop frequency of the Super Bonus in games

AVRG TKT=000030
BONUS 1 in 50

SCREEN 6 MTR HRS

MTR HRS =000001

CLEAR METERS This option allows you to clear all bookkeeping data.
 WARNING – ONCE DELETED THIS INFORMATION CAN NOT BE RESTORED

CLEAR METERS

Press the TEST button to show the clear message.

CLEAR METERS
ARE YOU SURE? Y

Press the SERVICE button to change between N and Y.
 Press the TEST button to confirm your selection.

CLEAR IOU This option allows you to clear any tickets that have not been paid out.
 WARNING – ONCE DELETED THIS INFORMATION CAN NOT BE RESTORED

CLEAR IOU

Press the TEST button to show the clear message.

CLEAR IOU
ARE YOU SURE? Y

Press the SERVICE button to change between N and Y.
 Press the TEST button to confirm your selection.

CLEAR SRV CREDIT This option allows you to clear any unused service credits .
 WARNING – ONCE DELETED THIS INFORMATION CAN NOT BE RESTORED

CLEAR SRV CREDIT

Press the TEST button to show the clear message.

CLEAR SRV CREDIT
ARE YOU SURE? Y

Press the SERVICE button to change between N and Y.
 Press the TEST button to confirm your selection.
 Press the TEST button to exit BOOKKEEPING and return to the TEST MENU.

EXIT MENU.

SET DATE/TIME

Select SET DATE/TIME from the Test Menu screen to enter the SET DATE/TIME menu.

TEST MENU
10.SET DATE/TIME

This screen is used to set the time and date of the system. The current date and time setting for the system is always displayed at the top of the screen. Below allows for each setting to be adjusted.

Use the SERVICE button to change between the different options.
 Use the TEST button to increase the setting value by 1.

ADJUST DATE This will change the date of the month.
 Range between 1 and 28, 29, 30 or 31 depending on month and year.

24/03/13 15:05
ADJUST DATE

ADJUST MONTH This will change the month.
 Range between 1 and 12

24/03/13 15:05
ADJUST MONTH

ADJUST YEAR This will change the year.
 Range between 01 and 99

24/03/13 15:05
ADJUST YEAR

ADJUST HOURS This will change the hour.
 Range between 00 and 23

24/03/13 15:05
ADJUST HOUR

ADJUST HOURS This will change the minutes.
 Range between 00 and 59

24/03/13 15:05
ADJUST MINUTES

EXIT MENU. Press the TEST button to exit SET DATE/TIME and return to the TEST MENU.

EXIT

Select EXIT from the Test Menu screen to exit from the TEST MENU and return to the game .

TEST MENU
11.EXIT

10 CONTROLLER UNIT(S)

⚠ WARNING

- When working with the product, be sure to turn the power off. Working with the power on may cause an electric shock or short circuit.
- Be careful not to damage the wires. Damaged wires may cause an electric shock, short circuit or present a risk of fire.
- Exercise due caution in performing soldering work. If soldering iron is handled carelessly, there could be fires or burns.

⚠ CAUTION

- When fastening plastic parts, be careful not to tighten screws or nuts excessively. If these are tightened to excess, parts could be damaged, resulting in injuries from fragments, etc.
- After the unit has been disassembled and reassembled again, check carefully that the unit has been reassembled correctly.
- Be sure to inspect the outer elements on both controller units.
- Resemble so that there is no gap between plates and covers. If there is a gap or rattling, the players could get fingers or hands caught, resulting in injury.

STOP IMPORTANT

- Be careful not to damage or lose small parts or screws.
- When a part has been replaced, be sure to always make adjustments and check conditions in Test Mode.

STOP IMPORTANT

Be sure to remove the power before attempting service or repair to the controller. Failure to remove power may result in component damage or shock hazard.

In cases where the Handle operability is poor and/or the adjustment or replacement of the POT is required. It may be necessary to replace either the COIL or the POT from within the controller depending on the fault condition. In game, when the handle is pulled fully along its path the gage around the outside of the upper disc should indicate a MAX spin. If this is not the case then it is possible that the POT within the controller may need to be adjusted or replaced. Carefully follow the instructions below to carry out this operation.

10-1 AJUSTING/CHANGING THE POT

An adjustable wrench is required for the following procedure.

- 1 Turn off the power.
- 2 Using the key - open the Console lid to access either left or right controllers.

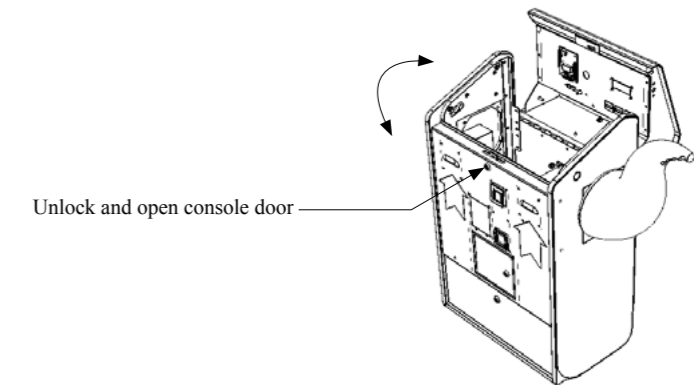

- 3 Locate the mechanics of the controller. Take care when working in this area. DO NOT pull on the handle when working on the controller. Keep fingers away from moving parts at all times.

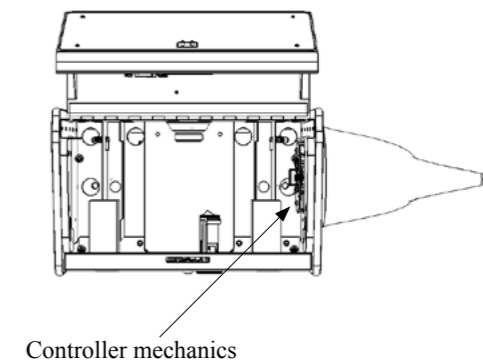

4 Locate the potentiometer.

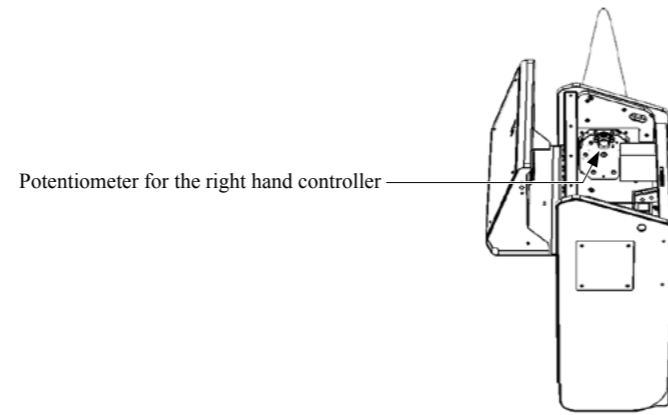

5 Locate and remove the (2) Hex Bolts which secure the Potentiometer Bkt to the controller mech.

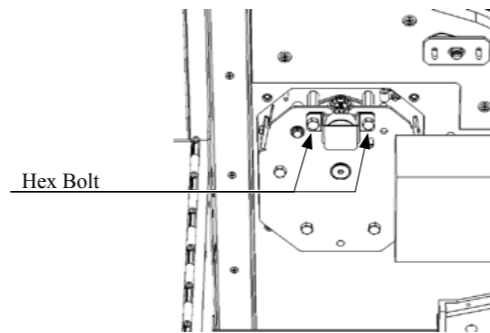

6 Carefully remove the potentiometer and brkt taking care not to damage any wires..

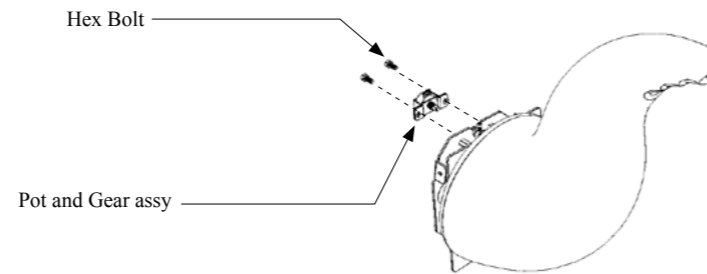

REPLACEMENT PROCEDURE

This procedure requires the following tools: Phillips screwdriver for the M4 screws, 1.5 mm hexagonal wrench, 11-12 mm monkey wrench, nipper, cutter, wire stripper, soldering iron, industrial dryer and heat-shrinkable tube.

- 1** Using a soldering iron - desolder the 3 wires which are connected to the pot. Make note of the position of the wires before desoldering.
- 2** Slacken off the Gear retaining screw and pull the gear off the stem of the potentiometer.
- 3** Remove the nut securing the VR Bracket, then separate the Volume from the VR Bracket and replace it.
- 4** Remove the nut securing the VR Bracket, then separate the Volume from the VR Bracket and replace it.

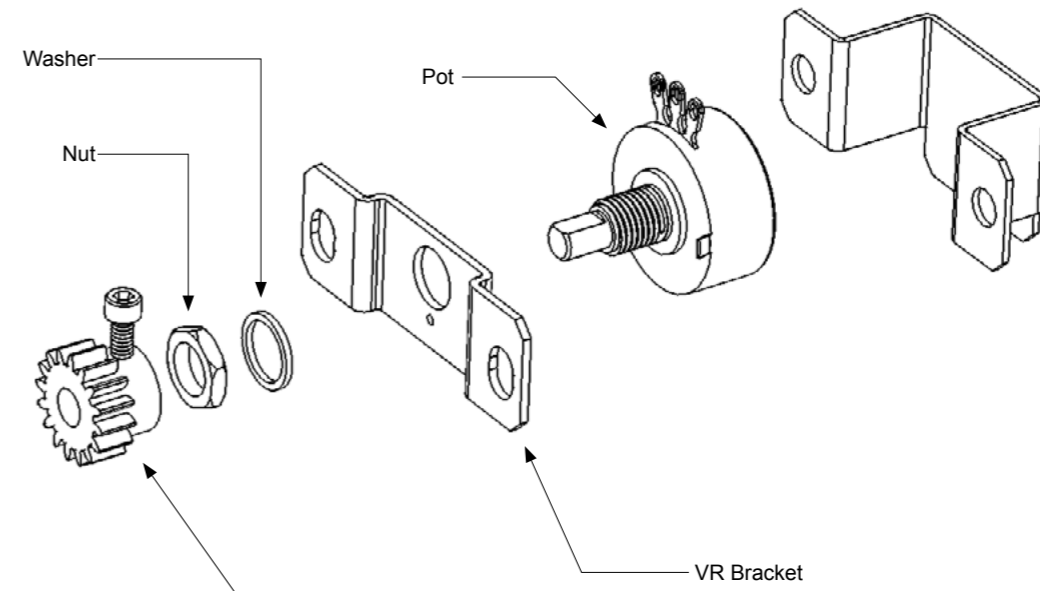

5 Fit individual pieces of heat shrinkable tubing over the insulation of the (3) wires and solder them into place in the same formation as when removed. When cool, place the tubing over each solder joint and heat to shrink in place.

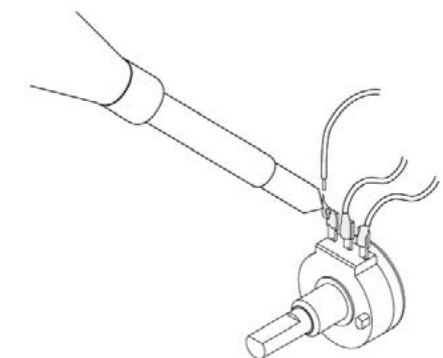

6 Refit the pot to the VR bracket keeping the pot in the same orientation as when initially removed.

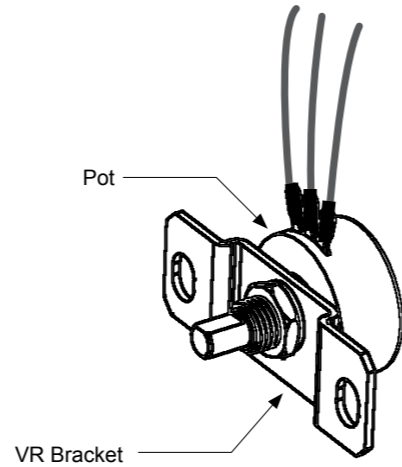

7 Fit the Gear to the pot shaft taking care not to overtighten the fixing as this could damage the thread inside the gear.

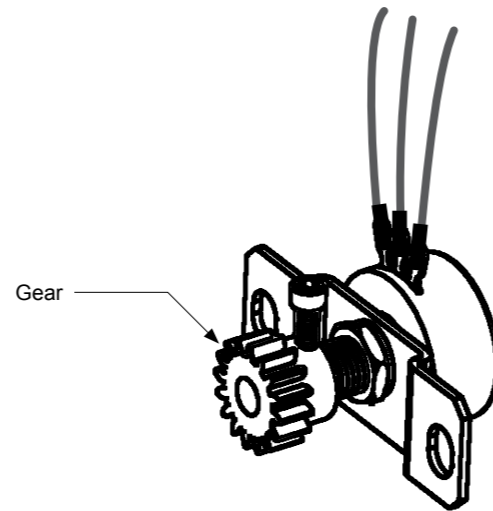

8 Manually center the pot and reposition it back into the controller mecha and secure.

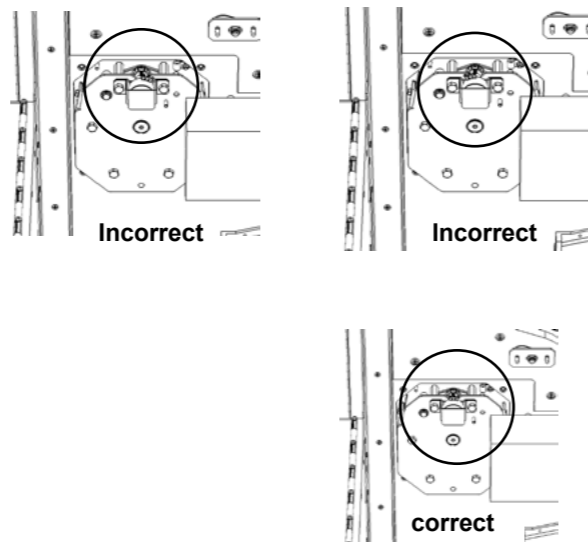

10-2 GREASING

STOP IMPORTANT

- Be sure to use the designated grease. Using undesignated grease can cause parts damage.
- Do not apply grease to locations other than as specified. Doing so may create a risk of operational problems and deterioration of parts.
- The designated periods for greasing serve only as a guide. Whenever there are squeaks or other anomalies, apply grease at designated locations.

Use spray grease once every three months to grease up the gear mesh portion of the constituent parts. Use "Grease Mate" (part number 090-0066) for the spray grease.

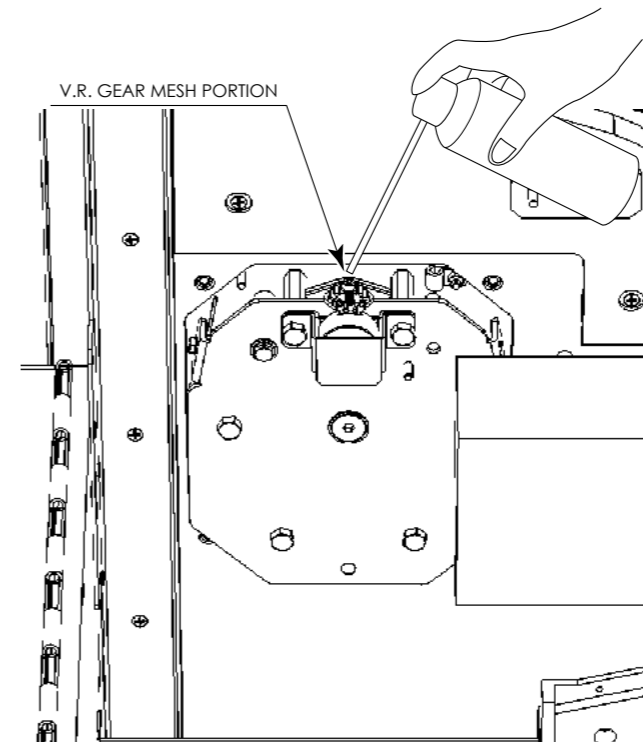

11 FEATURE REEL / TRACKER

The main feature of this game is the feature reel or tracker.
 Each time a handle is pulled, the feature reel will revolve at a speed chosen by the player when pulling down on the handle. The speed of the reel is determined using the gauge on the Control Panel. When a player pulls down on the handle the gauge increases accordingly. The further a handle is pulled down the faster/longer the reel will spin.

For information of replacing the LED's within the feature reel please refer to Chapter 13 - Lamps and Lighting in this manual.

11-1 CHANGING THE TRACKER / REEL BAND

The Game is presented in three formats, a £2/€2/\$2 game a £1/€1/\$1 game and a 50p/50c/50¢ game. The denomination of the game is determined by the feature band. By default the games are shipped from the manufacturers with the £1/€1/\$1 band fitted. The £2/€2/\$2 and 50p/50c/50¢ bands are both supplied in the installation kit box alongside this manual and the billboard.

- 1 Remove the power from the cabinet and disconnect the power lead.
- 2 Remove the Ladder Artboard by unscrewing the (8) M4x30 MSCR PH BLK from the outer edges.

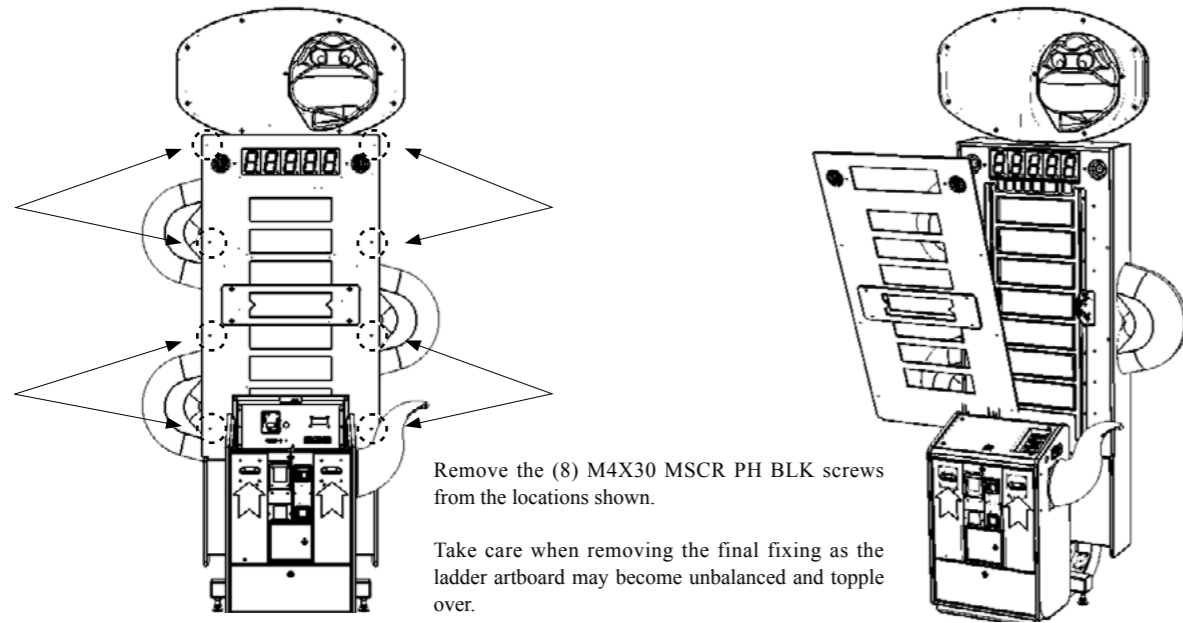

- 3 Remove the Ladder light board - Unscrew the single fixing which supports the ladder light board. Carefully tilt the board towards you and rest it on the Console cabinet. Disconnect the harnesses to the ladder light board located at the lower left hand corner. Lift out the board and place it carefully to one side.

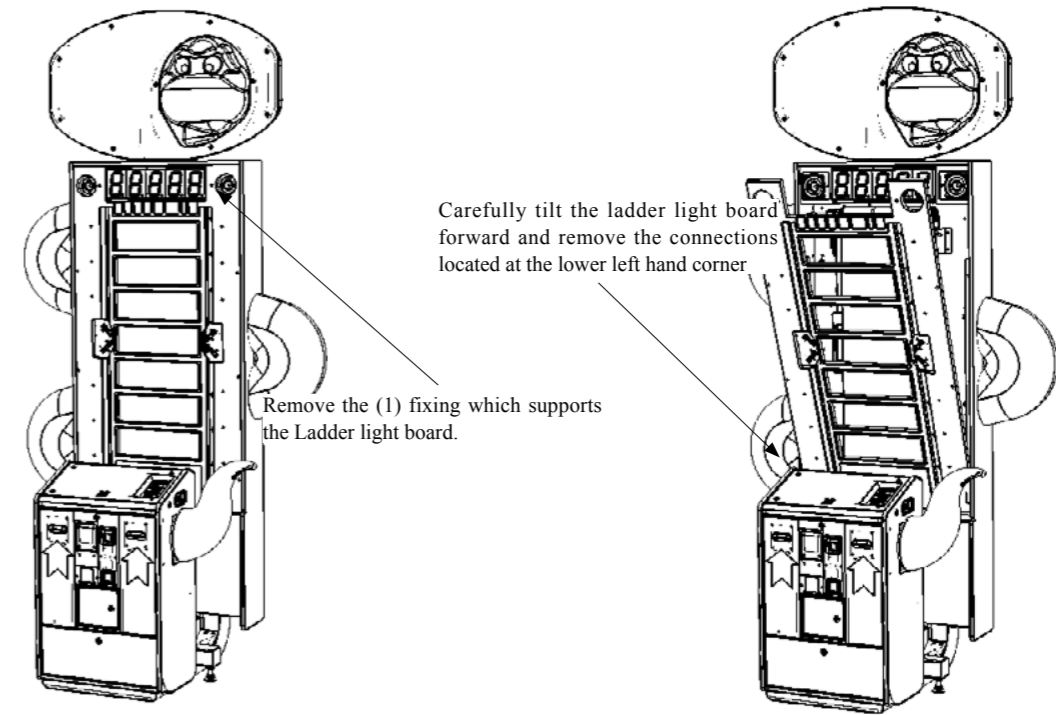

- 4 Removing the Tracker/Reel Band - Locate the (4) M5 Hex nuts positioned at each corner of the Tracker assembly and loosen. Locate and disconnect the Tracker harness.

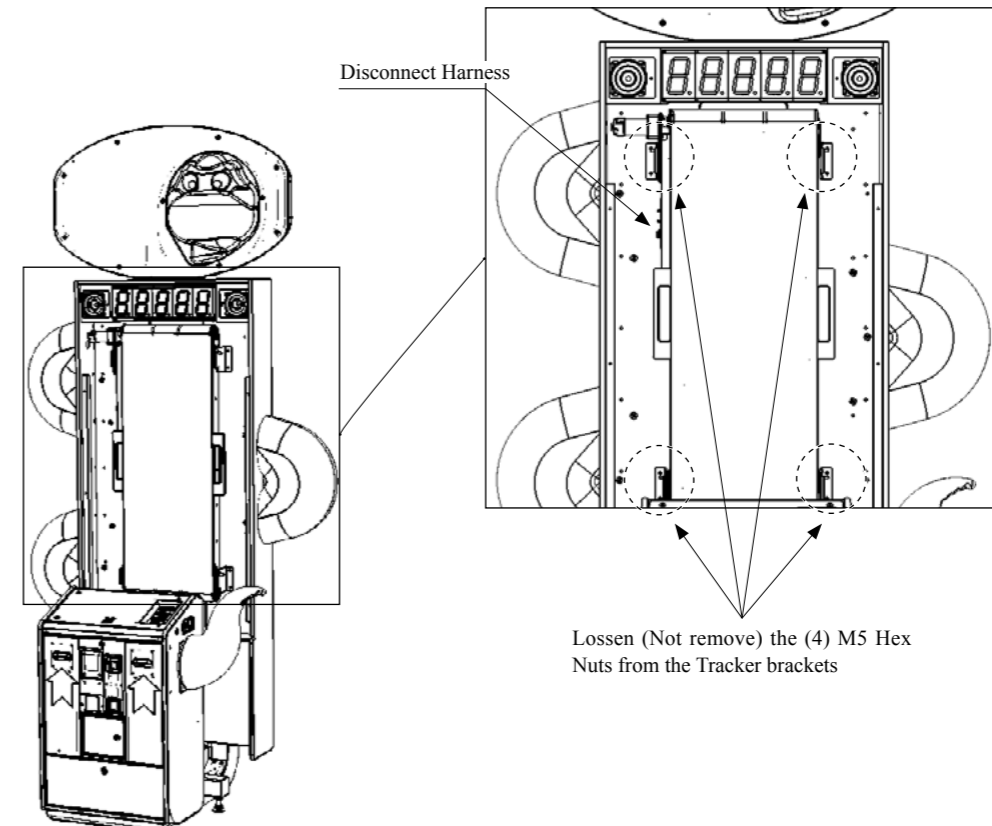

5 Once all harnesses are disconnected carefully hold the Tracker unit by the handles and lift to remove.

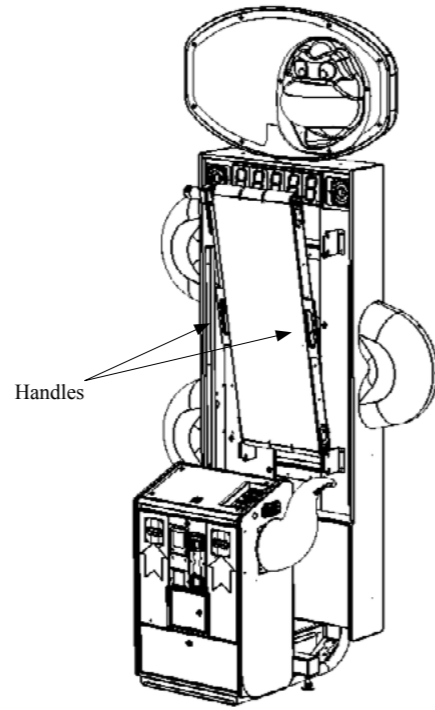

6 To remove the band - loosen the tension from the band by rotating the tension bracket through 90 degrees. This will enable the unit to compress slightly so that the band can be removed.

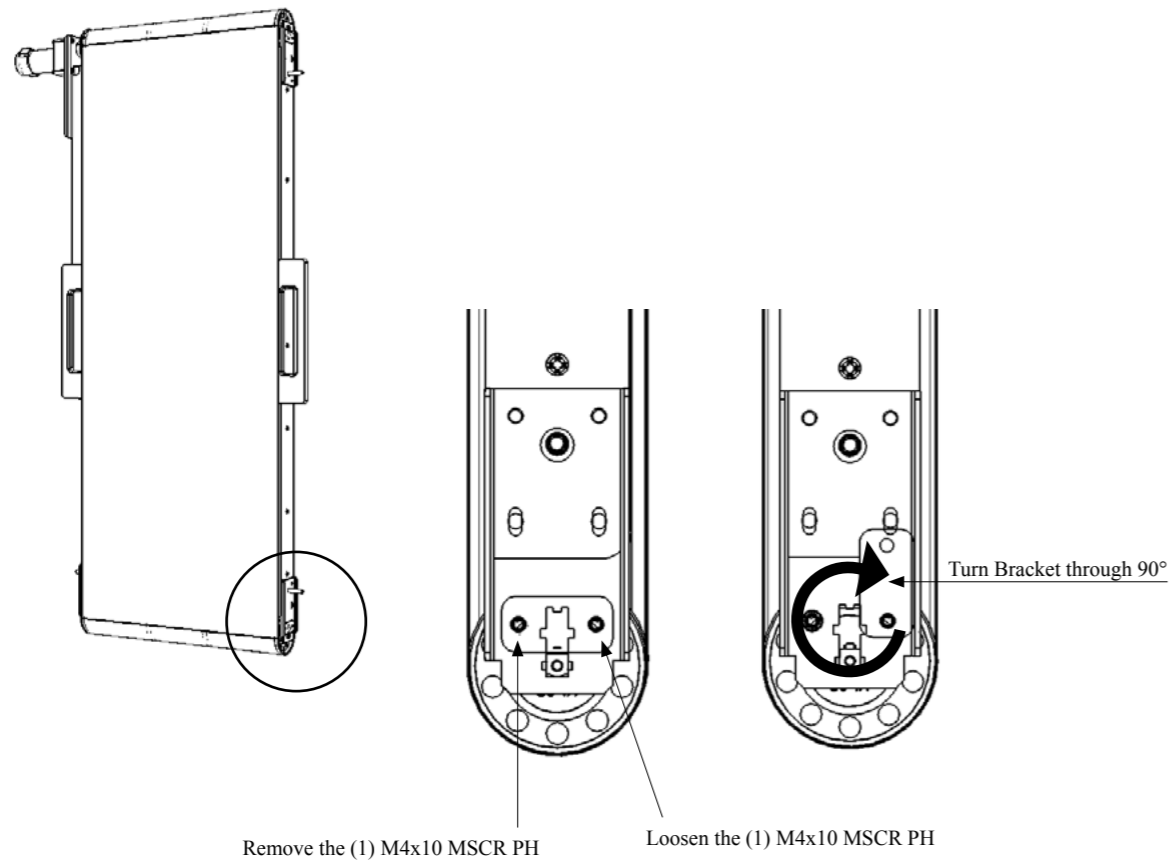

7 Once the Tracker tension bracket has been repositioned, carefully push on the wheel to release the band.

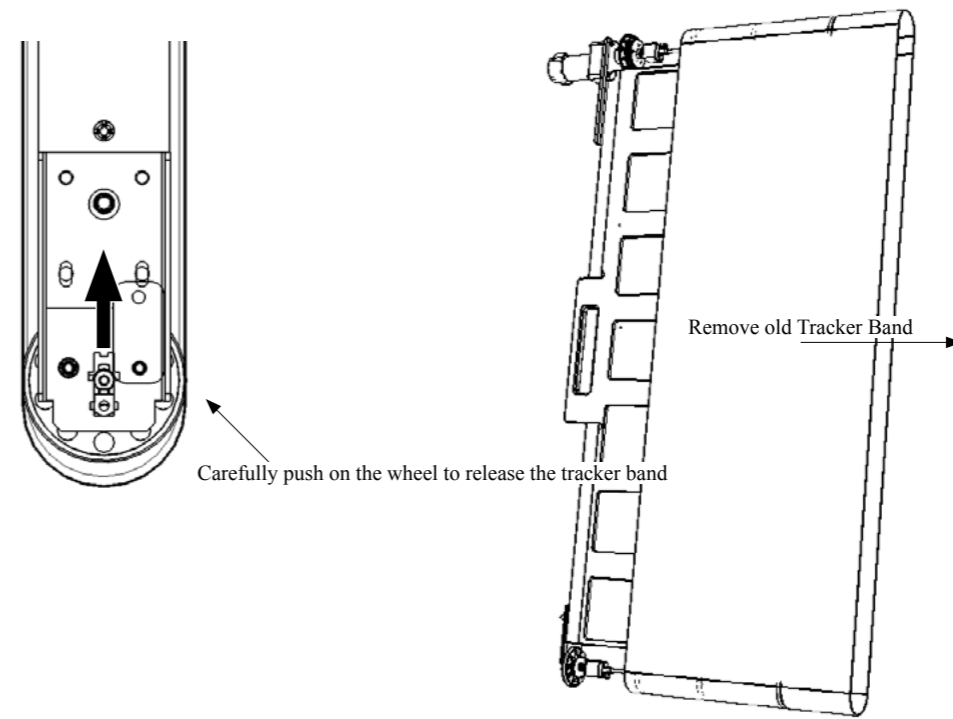

8 Fit the NEW band onto the Tracker Unit in the same way by following these instructions in reverse order

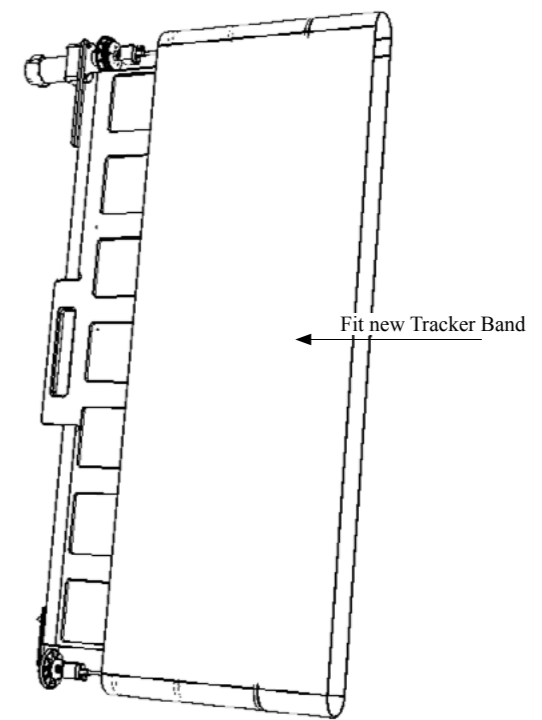

12 COIN HANDLING

Handling the Coin Jam

If the coin is not rejected when the REJECT button is pressed, open the coin chute door and open the selector gate. After removing the jammed coin, put a normal coin in and check to see that the selector correctly functions.

12-1 CLEANING THE COIN SELECTOR

STOP IMPORTANT

- Remove and clean smears by using a soft cloth dipped in water or diluted chemical detergent and then squeezed dry.
- Never apply machine oil, etc. to the Coin Selector.
- After cleaning the Coin Selector, insert a regular coin in the normal working status and ensure that the selector correctly functions.

The Coin Selector should be cleaned once every 3 months. When cleaning, follow the procedure below:

- 1 Turn the power for the machine OFF. Open the Coin Chute Door
- 2 Remove the Coin Selector from the Coin Chute Door
- 3 Open the gate and dust off by using a soft brush (Small soft Paint Brush, etc.)

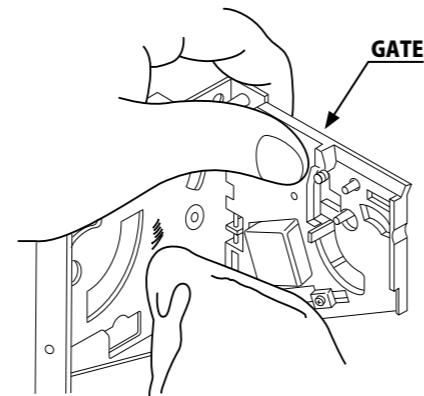

12-1 FIG 1

CLEANING THE COIN SELECTOR (MECHANICAL).

- 1 Remove and clean smears by using a soft cloth dipped in water or diluted chemical detergent and then squeezed dry.
- 2 Remove the CRADLE.. When removing the retaining ring (E ring) be very careful so as not to bend the rotary shaft.
- 3 Remove stain from the rotary shaft and shaft receiving portions by wiping off with a soft cloth. etc.
- 4 After wiping off as per previous step, further apply a dry cloth to completely dry the Coin Selector.

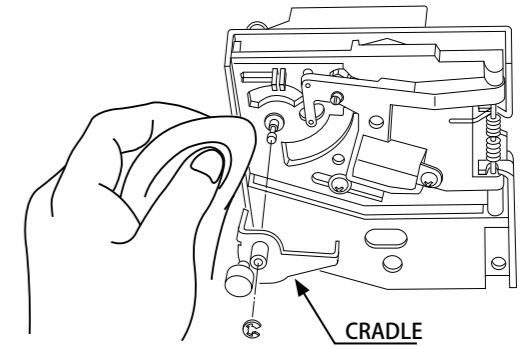

12-1 FIG 2

Coin Insertion Test

Once every month, when performing the Coin SW Test, simultaneously check the following:

Does the Coin Meter count satisfactorily?

Does the coin drop into the cashbox correctly?

Is the coin rejected when inserted while keeping the REJECT Button pressed down?

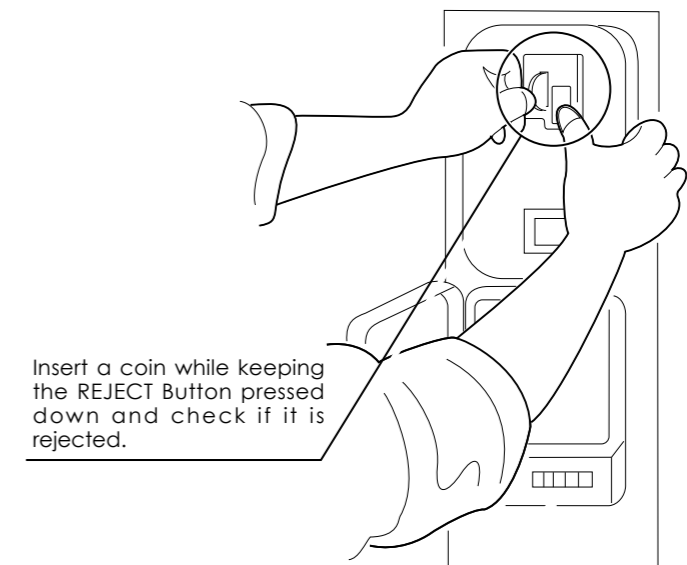

12-1 FIG 3

1 Remove and clean smears by using a damp soft cloth dipped in water. DO NOT use any diluted chemical detergent or cleansing agent as this will impair the workings of the component.

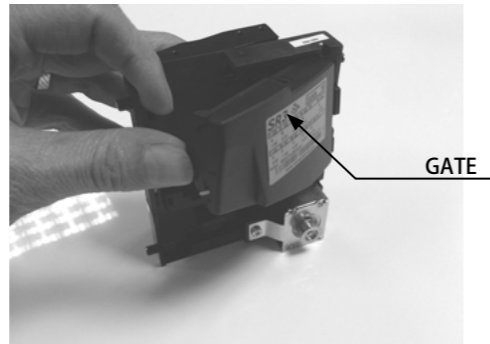

2 Open the reject gate to gain access to the rundown path.

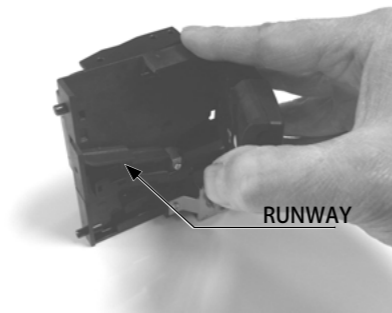

3 Remove the dirt and stains from the runway by wiping off with a soft damp cloth.



4 After wiping off as per previous step, further apply a dry cloth to completely dry the coin Selector.

12-2 FAULT FINDING

Fault Finding

The following information is presented for customers' guidance in rectifying a fault but does not cover all possible causes.

All acceptors with electronic faults should be returned to an approved service centre for repair.

| SYMPTOM | INVESTIGATE | POSSIBLE CAUSE |
|--|-----------------------|--|
| Acceptor does not work (all coins reject) | Connector | Poor Contact |
| | | Loose Wire |
| | Power Supply | Not switched on |
| | | Incorrect voltage |
| | | Inadequate current |
| | | Rise time too slow |
| | Inhibit all inputs | Acceptor Inhibited |
| | Accept gate | Gate not free or dislocated |
| | Accept channel | Obstruction |
| | Reject gate | Not fully closed |
| LED on rear cover RED | EEPROM chksm error | |
| | SR Sensor fault | |
| | Credit opto fault | |
| LED on rear cover YELLOW | Credit sensor blocked | |
| | Reject lever pressed | |
| Poor Acceptance | Power Supply | Reinstall power |
| | Accept gate | Voltage less than 10v (Voltage drops when coil engages) |
| | Connector | Gate jam or dislocated |
| | Coin rundown | Loose |
| | Bank Select | Dirty |
| Coin stick or jam in acceptor. | Accept channel | Both banks enabled |
| | Accept gate | Acceptor dirty or may have some damage |
| | Reject gate | |
| A true coin type rejects | Label | Coin not programmed |
| No accept signal | Connector | Loose or broken wire |
| | Accept channel | Path dirty or obstructed |

REGIONAL AND ACCEPTOR SETTINGS (SW3)

| Country | Setting | Switch 3 Setting | | | | | Coin Validator Programming | | | | | | | | | | | | |
|---------------|-----------------------------|------------------|-----|-----|-----|-----|----------------------------|-------------|---------|-------|---------|------------|-----------|-----------|------------|-------|--------|--------|--------|
| | | SW1 | SW2 | SW3 | SW4 | SW5 | SW6 | COIN1 | COIN2 | COIN3 | COIN4 | COIN5 | COIN6 | COIN7 | COIN8 | COIN9 | COIN10 | COIN11 | COIN12 |
| UK | Coin Controls C220 Parallel | OFF | OFF | OFF | OFF | | £1 | 50p new | 20p | 10p | - | 50p old | - | - | - | - | - | - | - |
| UK | Coin Controls C220 Binary | ON | OFF | OFF | OFF | | £1 | 50p new | 20p | 10p | - | 50p old | - | £2 | - | - | - | - | - |
| UK | Coin Controls C220 Binary | OFF | ON | OFF | OFF | | £1 | 50p new | 20p | 10p | - | £2 | - | 50p old | - | - | - | - | - |
| UK | Coin Controls SR3 Parallel | ON | ON | OFF | OFF | | £1 | 50p new | 20p | 10p | - | £2 | - | 50p old | - | - | - | - | - |
| UK | Coin Controls SR3 Parallel | OFF | OFF | ON | OFF | | £2 | £1 | 50p new | 20p | 10p | - | - | - | - | - | - | - | - |
| Euro | Coin Controls SR3 Parallel | OFF | OFF | ON | OFF | | €2 | €1 | 50p new | 20p | 10p | - | - | - | - | - | - | - | - |
| UK | Mars ME/MS 111 Parallel | ON | OFF | ON | OFF | | £1 | £2 | 20p | 10p | 50p new | 50p old | - | - | - | - | - | - | - |
| UK | NRI Parallel | OFF | ON | ON | OFF | | 10p | 20p | 50p | £1 | £2 | - | - | - | - | - | - | - | - |
| Belgium | Parallel | ON | ON | ON | OFF | | - | 50BFr | 20BFr | 5BFr | - | - | - | - | - | - | - | - | - |
| Holland | Parallel | OFF | OFF | OFF | ON | | - | 5NLG | 2.5NLG | 1NLG | - | - | - | - | - | - | - | - | - |
| Austria | SR3 Parallel | ON | OFF | OFF | ON | | 20Sch | 10Sch | 5Sch | 1Sch | - | - | - | - | - | - | - | - | - |
| Spain | Coin Controls C220 Binary | OFF | ON | OFF | ON | | 500Pia | 200Pia | 100Pia | 50Pia | 25Pia | 200Pia old | 50Pia old | 25Pia old | 25Pia old | - | - | - | - |
| Spain | SR3/NRI Parallel | ON | ON | OFF | ON | | 500Pia | 200Pia | 100Pia | 50Pia | 25Pia | 200Pia old | 50Pia old | 25Pia old | 200Pia old | - | - | - | - |
| Spain | Coin Controls C220 Parallel | OFF | OFF | ON | ON | | 100Pia | 50Pia | 25Pia | 25Pia | 25Pia | 50Pia old | 25Pia old | 25Pia old | - | - | - | - | - |
| Portugal Euro | Parallel | ON | OFF | ON | ON | | 200Es | 100Es | 50Es | - | - | 50Pia old | - | 25Pia old | - | - | - | - | - |
| | TBA | | | | OFF | | TBA | TBA | TBA | TBA | TBA | TBA | TBA | TBA | TBA | TBA | TBA | TBA | TBA |
| | Channels | | | | ON | | TBA | Direct Mode | | | | | | | | | | | |
| | | | | | OFF | | 2 channel Mode | | | | | | | | | | | | |

Note: These switch settings are under constant review and may change due to world currency updates.
 Set SW 1 according to the option settings found in the relevant Price of Play Settings Table on the following pages.
 Set SW 3 on the VTS /Excel board as shown in the table above corresponding to the country required.

12-3 ADJUSTING THE PRICE OF PLAY (EXCEL)

STOP IMPORTANT

The price of play is determined by the configuration of switches located on either an EXCEL board or VTS board. The type of board used is determined by product location. Switch settings for both types of board remain the same.

This product comes equipped with a Crane NRI Coin Acceptor. To adjust the price of play ALL credit setting are adjusted via the EXCEL CREDIT BOARD.

The Credit Board is controlled by 2 DIL Switches. These allow the operator to select the price of play, type of coin acceptor and region.

EXCEL Credit Board

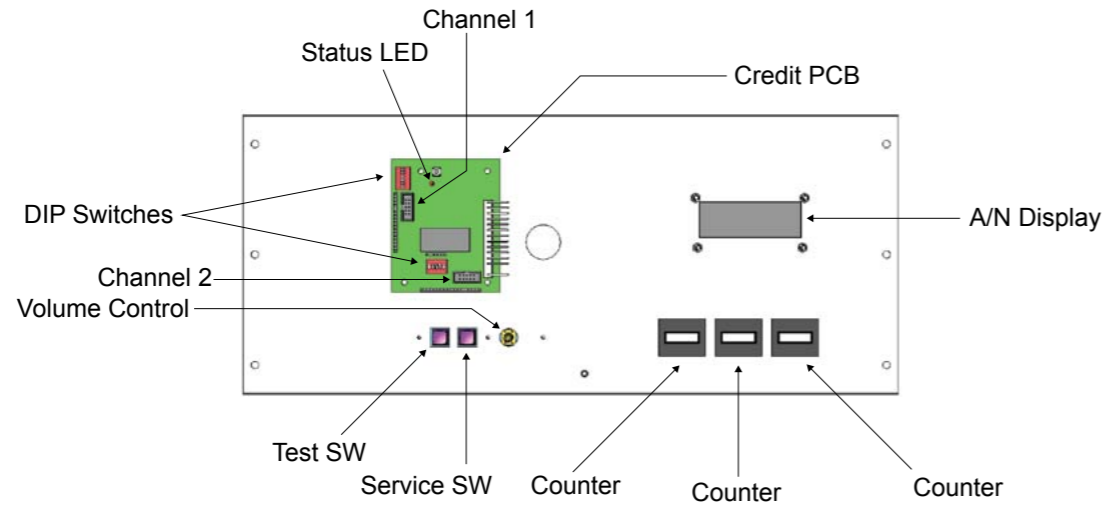

DIL SW3 (Regional Settings)
 Adjust these switches to specify the type of Coin Acceptor used and currency.

Default = SW1&SW2 ON - NRI in parallel mode, Sterling.

- TEST BUTTON Provides access to the TEST MENU when pressed.
- SERVICE BUTTON Provides a SERVICE CREDIT when pressed
- Status LED Flashes when functioning.
- CHANNEL 1 Not Used
- CHANNEL 2 To Coin Acceptor (SR3 TYPE.)
- DIL SW1 (credit settings) Adjust to required price of pay.
- VOL CONTROL MAIN VOLUME ADJUSTMENT (FRONT SPEAKERS)

EURO PRICE OF PLAY SETTINGS (SW1)

| Price | Bonus | | | | | DIL Switch 1 | | | | |
|-------|-------|---------------------------------|--------------------------------|---------------------------------|-----|--------------|-----|-----|-----|-----|
| | 1 | 2 | 3 | 4 | 5 | 1 | 2 | 3 | 4 | 5 |
| 1 | 10¢ | 50¢ = 5 plays | €1 = 10 plays | €2 = 20 plays | OFF | OFF | OFF | OFF | OFF | OFF |
| 2 | 10¢ | 50¢ = 6 plays @ 8.33p per play | €1 = 12 plays @ 8.33¢ per play | €2 = 24 plays @ 8.33¢ per play | ON | OFF | OFF | OFF | OFF | OFF |
| 3 | 20¢ | 50¢ = 2.5 plays | €1 = 5 plays | €2 = 10 plays | OFF | ON | OFF | OFF | OFF | OFF |
| 4 | 20¢ | 50¢ = 3 plays @ 16.66¢ per play | €1 = 6 plays @ 16.66¢ per play | €2 = 12 plays @ 16.66¢ per play | ON | ON | OFF | OFF | OFF | OFF |
| 5 | 30¢ | 50¢ = 1.66 plays | €1 = 3.33 plays | €2 = 6.66 plays | OFF | OFF | ON | OFF | OFF | OFF |
| 6 | 30¢ | 50¢ = 1.66 plays | €1 = 4 plays @ 25¢ per play | €2 = 8 plays @ 25¢ per play | ON | OFF | ON | OFF | OFF | OFF |
| 7 | 30¢ | 50¢ = 2 plays @ 25¢ per play | €1 = 4 plays @ 25¢ per play | €2 = 8 plays @ 25¢ per play | OFF | ON | ON | OFF | OFF | OFF |
| 8 | 30¢ | 50¢ = 2 plays @ 25¢ per play | €1 = 3 plays @ 33.33¢ per play | €2 = 6 plays @ 33.33¢ per play | ON | ON | ON | OFF | OFF | OFF |
| 9 | 40¢ | 50¢ = 1.25 plays | €1 = 2.5 plays | €2 = 5 plays | OFF | OFF | OFF | OFF | ON | OFF |
| 10 | 40¢ | 50¢ = 1.25 plays | €1 = 3 plays @ 33.33¢ per play | €2 = 6 plays @ 33.33¢ per play | ON | OFF | OFF | OFF | ON | OFF |
| 11 | 50p | 50p = 1 play | €1 = 2 plays | €2 = 4 plays | OFF | ON | OFF | OFF | ON | OFF |
| 12 | 50p | 50p = 1 play | €1 = 3 plays @ 33.3p per play | €2 = 6 plays @ 33.3p per play | ON | ON | OFF | OFF | ON | OFF |
| 13 | 50p | 50p = 1 play | €1 = 2 plays | €2 = 5 plays @ 40p per play | OFF | OFF | ON | OFF | ON | OFF |
| 14 | 60p | 50p = 0.83 play | €1 = 1.66 plays | €2 = 3.33 plays | ON | OFF | ON | OFF | ON | OFF |
| 15 | 60p | 50p = 0.83 play | €1 = 2 plays @ 50p per play | €2 = 4 plays @ 50p per play | OFF | ON | ON | OFF | ON | OFF |
| 16 | 80p | 50p = 0.62 play | €1 = 1.25 plays | €2 = 2.5 plays | ON | ON | ON | OFF | ON | OFF |
| 17 | 80p | €1 = 1.25 plays | €1.50 = 2 plays @ 75p per play | €2 = 2.5 plays | OFF | OFF | OFF | OFF | OFF | ON |
| 18 | €1 | 2x50p = 1 play | €1 = 1 play | €2 = 2 plays | ON | OFF | OFF | OFF | OFF | ON |
| 19 | €1 | 2x50p = 1 play | €1 = 1 play | €2 = 3 plays @ 66.6p per play | OFF | ON | OFF | OFF | OFF | ON |
| 20 | €1 | 2x50p = 1 play | €2 = 2 plays | €4 = 5 plays @ 80p per play | ON | ON | OFF | OFF | ON | ON |
| 21 | €1.50 | 3x50p = 1 play | €1 = 0.66 plays | €3 = 2 plays | OFF | OFF | ON | OFF | ON | ON |
| 22 | €1.50 | 3x50¢ = 1 play | €1 = 0.66 plays | €2 = 2 plays @ €1 per play | ON | OFF | ON | OFF | ON | ON |
| 23 | €2 | 4x50¢ = 1 play | €1 = 0.5 play | €2 = 5 plays @ 40¢ per play | OFF | OFF | ON | OFF | ON | ON |
| 24 | €2 | 4x50¢ = 1 play | €1 = 1.66 plays | €2 = 3.33 plays | ON | OFF | ON | OFF | ON | ON |
| 25 | €3 | 50¢ = 0.83 play | €1 = 2 plays @ 50¢ per play | €2 = 4 plays @ 50¢ per play | OFF | ON | ON | OFF | ON | ON |
| 26 | €3 | 50¢ = 0.83 play | €1 = 1.25 plays | €2 = 2.5 plays | ON | ON | ON | OFF | ON | ON |
| 27 | €5 | €1 = 0.2 play | €5 = 1 play | €10 = 2 plays | OFF | ON | OFF | OFF | ON | ON |
| 28 | €5 | €1 = 0.2 play | €5 = 1 play | €10 = 3 plays @ €3.33p per play | ON | ON | OFF | OFF | ON | ON |
| 29 | €7.50 | €5 = 0.66 play | €10 = 1.33 plays | €15 = 2 plays | OFF | OFF | ON | OFF | ON | ON |
| 30 | €7.50 | €5 = 0.66 play | €10 = 1.33 plays | €10 = 2 plays @ €5 per play | ON | OFF | ON | ON | ON | ON |
| 31 | €10 | €10 = 1 play | €20 = 2 play | €30 = 3 play | OFF | ON | ON | ON | ON | ON |
| 32 | | | Free Play | | ON | ON | ON | ON | ON | ON |

STERLING PRICE OF PLAY SETTINGS (SW1)

| Price | Bonus | | | | | DIL Switch 1 | | | | |
|-------|-------|---------------------------------|--------------------------------|---------------------------------|-----|--------------|-----|-----|-----|-----|
| | 1 | 2 | 3 | 4 | 5 | 1 | 2 | 3 | 4 | 5 |
| 1 | 10p | 50p = 5 plays | €1 = 10 plays | €2 = 20 plays | OFF | OFF | OFF | OFF | OFF | OFF |
| 2 | 10p | 50p = 6 plays @ 8.33p per play | €1 = 12 plays @ 8.33p per play | €2 = 24 plays @ 8.33p per play | ON | OFF | OFF | OFF | OFF | OFF |
| 3 | 20p | 50p = 2.5 plays | €1 = 5 plays | €2 = 10 plays | OFF | ON | OFF | OFF | OFF | OFF |
| 4 | 20p | 50p = 3 plays @ 16.66p per play | €1 = 6 plays @ 16.66p per play | €2 = 12 plays @ 16.66p per play | ON | ON | OFF | OFF | OFF | OFF |
| 5 | 30p | 50p = 1.66 plays | €1 = 3.33 plays | €2 = 6.66 plays | OFF | OFF | ON | OFF | OFF | OFF |
| 6 | 30p | 50p = 1.66 plays | €1 = 4 plays @ 25p per play | €2 = 8 plays @ 25p per play | ON | OFF | ON | OFF | OFF | OFF |
| 7 | 30p | 50p = 2 plays @ 25p per play | €1 = 4 plays @ 25p per play | €2 = 8 plays @ 25p per play | OFF | ON | ON | OFF | OFF | OFF |
| 8 | 30p | 50p = 2 plays @ 25p per play | €1 = 3 plays @ 33.33p per play | €2 = 6 plays @ 33.33p per play | ON | ON | ON | OFF | OFF | OFF |
| 9 | 40p | 50p = 1.25 plays | €1 = 2.5 plays | €2 = 5 plays | OFF | OFF | OFF | OFF | ON | OFF |
| 10 | 40p | 50p = 1.25 plays | €1 = 3 plays @ 33.3p per play | €2 = 6 plays @ 33.3p per play | ON | OFF | OFF | OFF | ON | OFF |
| 11 | 50p | 50p = 1 play | €1 = 2 plays | €2 = 4 plays | OFF | ON | OFF | OFF | ON | OFF |
| 12 | 50p | 50p = 1 play | €1 = 3 plays @ 33.3p per play | €2 = 6 plays @ 33.3p per play | ON | ON | OFF | OFF | ON | OFF |
| 13 | 50p | 50p = 1 play | €1 = 2 plays | €2 = 5 plays @ 40p per play | OFF | OFF | ON | OFF | ON | OFF |
| 14 | 60p | 50p = 0.83 play | €1 = 1.66 plays | €2 = 3.33 plays | ON | OFF | ON | OFF | ON | OFF |
| 15 | 60p | 50p = 0.83 play | €1 = 2 plays @ 50p per play | €2 = 4 plays @ 50p per play | OFF | ON | ON | OFF | ON | OFF |
| 16 | 80p | 50p = 0.62 play | €1 = 1.25 plays | €2 = 2.5 plays | ON | ON | ON | OFF | ON | OFF |
| 17 | 80p | €1 = 1.25 plays | €1.50 = 2 plays @ 75p per play | €2 = 2.5 plays | OFF | OFF | OFF | OFF | OFF | ON |
| 18 | €1 | 2x50p = 1 play | €1 = 1 play | €2 = 2 plays | ON | OFF | OFF | OFF | OFF | ON |
| 19 | €1 | 2x50p = 1 play | €1 = 1 play | €2 = 3 plays @ 66.6p per play | OFF | ON | OFF | OFF | OFF | ON |
| 20 | €1 | 2x50p = 1 play | €2 = 2 plays | €4 = 5 plays @ 80p per play | ON | ON | OFF | OFF | ON | ON |
| 21 | €1.50 | 3x50p = 1 play | €1 = 0.66 plays | €3 = 2 plays | OFF | OFF | ON | OFF | ON | ON |
| 22 | €1.50 | 3x50p = 1 play | €1 = 0.66 plays | €2 = 2 plays @ €1 per play | ON | OFF | ON | OFF | ON | ON |
| 23 | €2 | 4x50p = 1 play | €1 = 0.5 play | €2 = 5 plays @ 40¢ per play | OFF | OFF | ON | OFF | ON | ON |
| 24 | €2 | 4x50p = 1 play | €1 = 1.66 plays | €2 = 3.33 plays | ON | OFF | ON | OFF | ON | ON |
| 25 | €3 | 6x50p = 1 play | €1 = 2 plays @ 50p per play | €2 = 4 plays @ 50p per play | OFF | ON | ON | OFF | ON | ON |
| 26 | €3 | 6x50p = 1 play | €1 = 1.25 plays | €2 = 2.5 plays | ON | ON | ON | OFF | ON | ON |
| 27 | €5 | €1 = 0.2 play | €5 = 1 play | €10 = 2 plays | OFF | ON | OFF | OFF | ON | ON |
| 28 | €5 | €1 = 0.2 play | €5 = 1 play | €10 = 3 plays @ €3.33p per play | ON | ON | OFF | OFF | ON | ON |
| 29 | €7.50 | €5 = 0.66 play | €10 = 1.33 plays | €15 = 2 plays | OFF | OFF | ON | OFF | ON | ON |
| 30 | €7.50 | €5 = 0.66 play | €10 = 1.33 plays | €10 = 2 plays @ £5 per play | ON | OFF | ON | ON | ON | ON |
| 31 | €10 | €10 = 1 play | €20 = 2 play | €30 = 3 play | OFF | ON | ON | ON | ON | ON |
| 32 | | | Free Play | | ON | ON | ON | ON | ON | ON |

13 LAMPS AND LIGHTING

⚠ WARNING

- When working with the product, be sure to turn the power off. Working with the power on may cause an electric shock or short circuit.
- Be sure to use lamps of the designated rating. Using lamps of undesignated rating can cause a fire or malfunctioning.
- There is the danger of short circuits or smoke generation due to deterioration of insulation in lighting fixtures resulting from age deterioration. Check for anomalies such as the following: Does it smell like something is burning? Is there socket discoloration? Are any lamps being replaced frequently? Do lamps not go on properly?

⚠ CAUTION

The Coin Door Lamp utilises a 12v 1.2w Wedge Bulb. It is important that you replace this bulb or any other bulb of that of the same voltage and rating. Failing to observe this caution may result in PCB failure or possible fire hazard.

13-1 REPLACING THE COIN DOOR LAMP

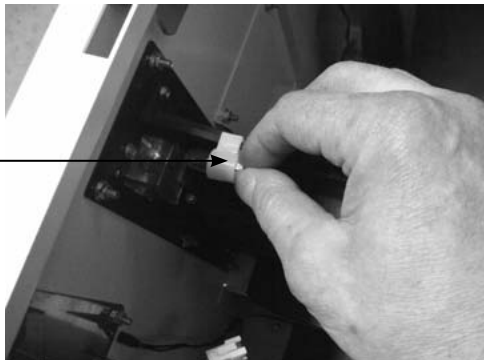
Step 1. Open the Console lid and locate the Lamp Housing directly behind the Coin Insert Bezel.  Lamp Housing

Step 2. Hold the Lamp Housing firmly between your index finger and thumb and gently pull upwards. Do Not try to remove the Lamp Housing whilst holding the bulb as the bulb may break causing injury.

Step 3. Once the Lamp Housing has been removed, carefully hold the bulb between your fingers and pull the Lamp Housing away.

Do not twist either bulb or Lamp Housing whilst removing the bulb as this may cause damage to both bulb and or Housing.

Type: Wedge Bulb - 12v, 1.2w

Step 4. Simply push-fit a replacement bulb of the same type and follow these steps in reverse to refit.



13-2 REPLACING THE LADDER / WINLINE LED's

⚠ WARNING

TAKE CARE WHEN ACCESSING THE INTEGRAL PARTS OF THE MACHINE.
MAKE SURE POWER IS REMOVED BEFORE SERVICING.
ONLY TOUCH PARTS WHICH ARE OUTLINED IN THE INSTRUCTIONS BELOW. FAILURE TO OBSERVE THIS CAUTION MAY RESULT IN INJURY OR COMPONENT DAMAGE.

REMOVING THE LADDER ARTWORK PANEL

1 REMOVE THE POWER and DISCONNECT THE POWER CABLE

2 To access the LEDs remove the Ladder Artwork Panel by unscrewing the (8) M4x30 MSCR PH BLK from the outer edges.

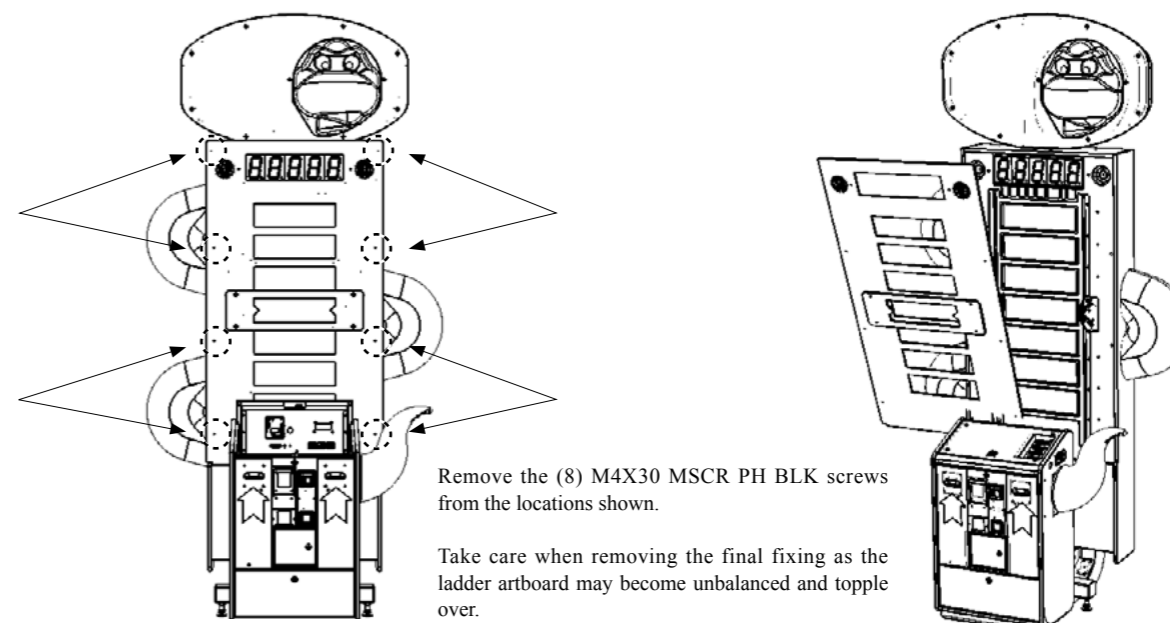

The LED strips are positioned upon each rung of the ladder (including the uprights), The center WIN LINE and the "SUPERWIN" feature at the top of the Ladder.

3 The LED strips are adhered to the ladder board using a purpose adhesive strip. Identify the LED strip which is to be changed, disconnect it and carefully peel it away from the Ladder Board.

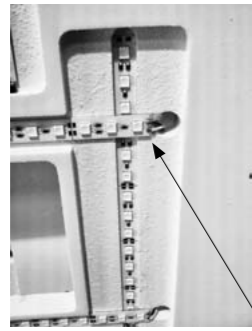

Locate LED strip to be replaced.



Disconnect connector at rear of board

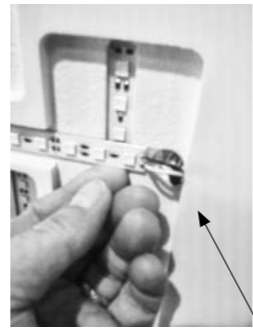

Carefully peel away LED strip

4 Apply the NEW LED strip by peeling away the protective backing and carefully placing it in to position. Press firmly along the length of the strip between each LED segment taking care not to apply too much pressure. Reconnect the LED harness.



Peel away the protective backing tape

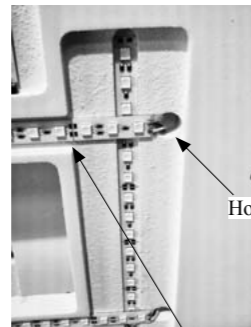

Apply the new LED strip into loaction and feed the harness through the hole in the ladder board

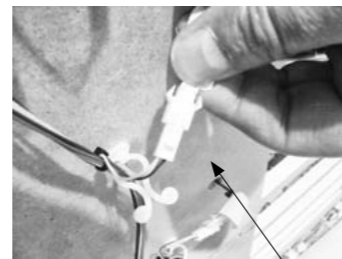

Reconnect connect the harness at rear of board

5 Follow step 2 in reverse to re attach the Ladder Artwork Panel taking care not to overtighten the fixings.

13-3 REPLACING THE 5 DIGIT NUMERIC DISPLAY

WARNING

**TAKE CARE WHEN ACCESSING THE INTEGRAL PARTS OF THE MACHINE.
MAKE SURE POWER IS REMOVED BEFORE SERVICING.
ONLY TOUCH PARTS WHICH ARE OUTLINED IN THE INSTRUCTIONS BELOW. FAILURE TO OBSERVE THIS CAUTION MAY RESULT IN INJURY OR COMPONENT DAMAGE.**

REMOVING THE WHT LED ARRAY

- 1** REMOVE THE POWER and DISCONNET THE POWER CABLE
- 2** Follow instruction 2 from the previous step to remove the Ladder Artwork Panel.

Remove Ladder Artwork Panel using instructions from previous step.

5 Digit Numeric Display.

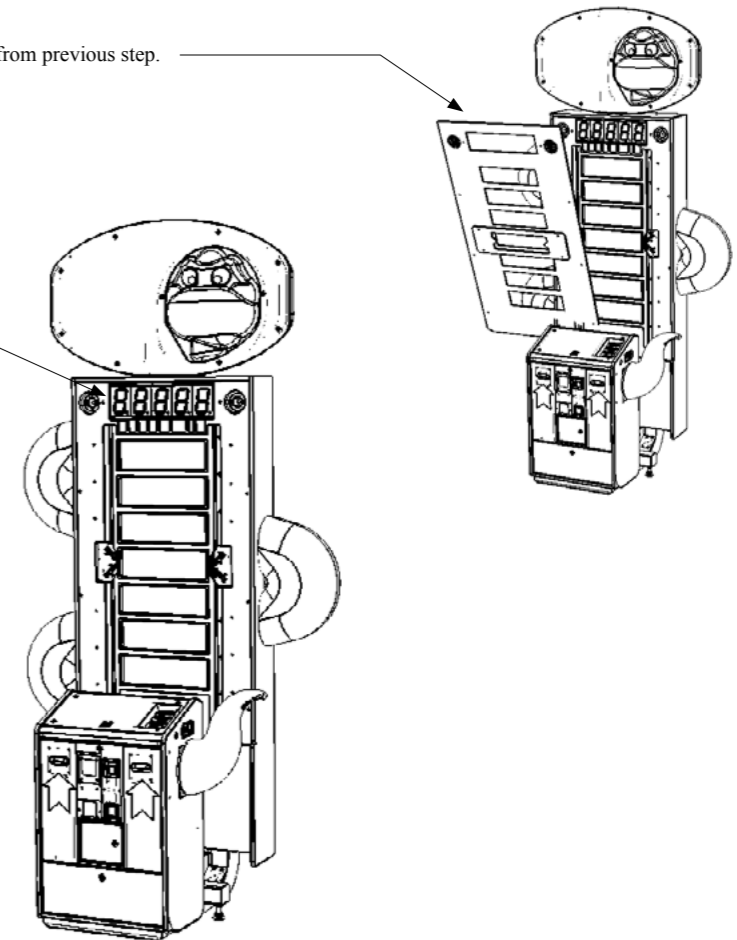

3 The 5 digit LED Board is located at the top of the cabinet. To remove the LED board simply press the locating pins on each of the 4 PCB mounts to release. Disconnect harness at rear of PCB and remove.



5 Digit LED Display

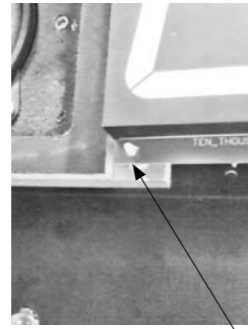

PCB mount

4 Replace the 5 Digit LED board and reassemble by following these instructions in reverse order.

13-4 REPLACING THE LED (WHT) SNAKE BODY

1 Locate the Snake Body segment to which the LEDs are to be replaced.

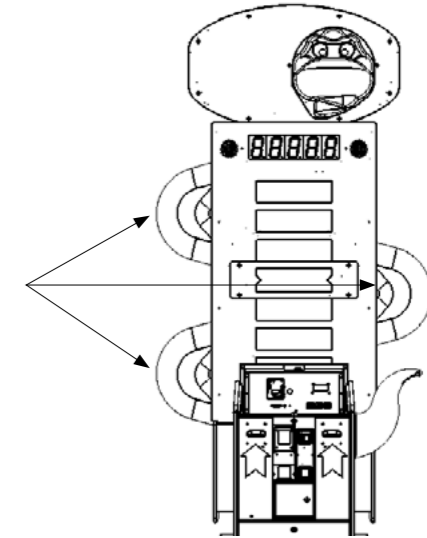

2 Remove the (5) M4 fixings from around the outer edge of the segment.

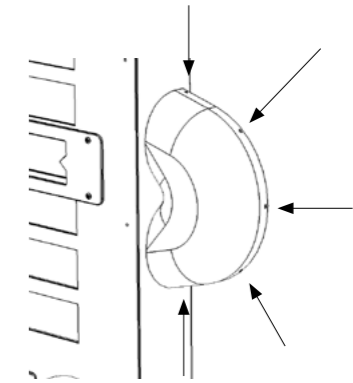

3 Carefully slide off the acrylic shell to reveal the LED strips.

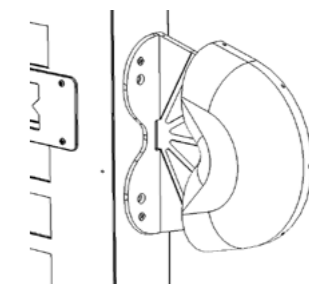

4 Each of the (5) LED strips are adhered to the back of the Snake Body. Disconnect the harness to the LED strip to be removed and carefully peel away the LED strip from the board.

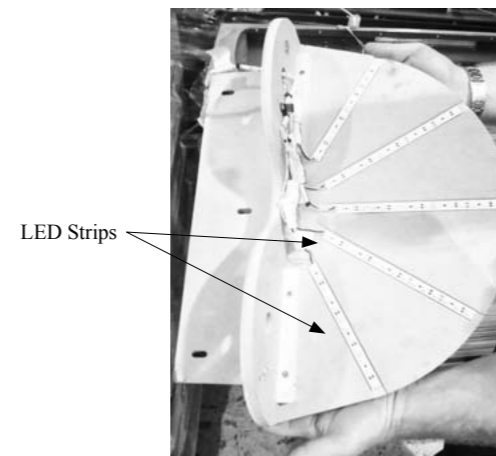

5 Peel the backing away from the NEW LED strip to be added and offer up to Snake Body. Adhere into position pressing firmly along the strip to complete adhesion.

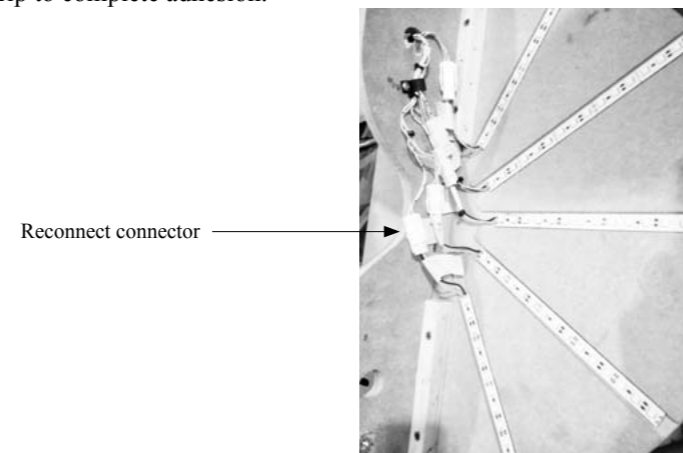

6 To refit the Snake Body Cover and secure into place - follow these instructions in reverse order.

13-5 REPLACING THE LED (WHT) FEATURE REEL / TRACKER

CAUTION

The LED Strips behind the Feature or Tracker Band are soldered in its connection to the harness, Take care when using appliances such as soldering/desoldering equipment. Only qualified personel should carry out such tasks.

WARNING

TAKE CARE WHEN ACCESSING THE INTEGRAL PARTS OF THE MACHINE.
 MAKE SURE POWER IS REMOVED BEFORE SERVICING.
 ONLY TOUCH PARTS WHICH ARE OUTLINED IN THE INSTRUCTIONS BELOW. FAILURE TO OBSERVE THIS CAUTION MAY RESULT IN INJURY OR COMPONENT DAMAGE.

- 1** REMOVE POWER from the cabinet and diconnect the POWER LEAD.
- 2** Follow steps 1 through to 8 on Chapet 11 section 1 of this manual to remove Tracker Unit and Feature Band.
- 3** Remove the Feature band to reveal the individual LED Strips.

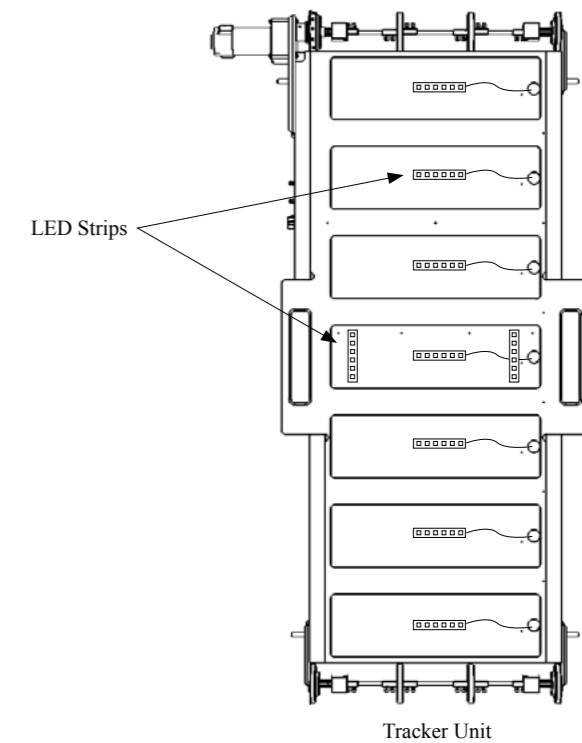

- 4** The LED Strips are adhered into position but the connections are soldered into place. Before removal take note of the position of the wires. To remove the LED Strips, unsolder the two wires (Yel & Blk). Then carefully peel away the LED Strip to remove.

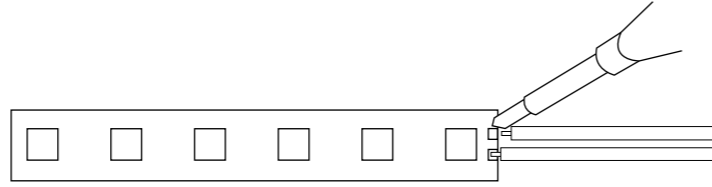

- 5** On the NEW LED strip, peel off the protective backing and adhere it in place. Resolder the wires in the same location as when removed.

- 6** Reassemble following the instructions in Chapter 11 section 1 of this manual in reverse order.

13-6 REPLACING THE LED (RGB) PULL

- 1** REMOVE POWER from the cabinet and disconnect the POWER LEAD.
- 2** Remove the Control Panel Acrylic by unscrewing the (4) fixing located at each corner of the Console Lid.

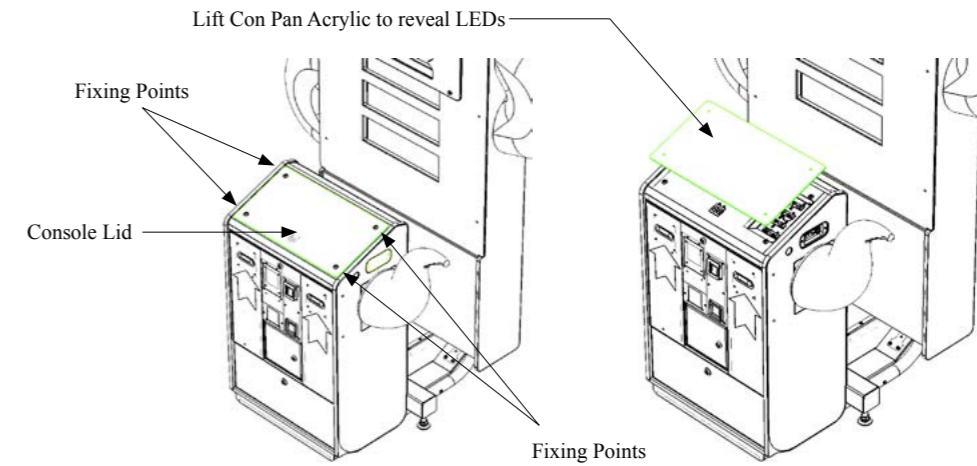

- 3** Locate the LED PCB to be replaced. To remove, press in the latch on the PCB Mount to release. Disconnect harness and remove. *NOTE ORIENTATION OF PCB*

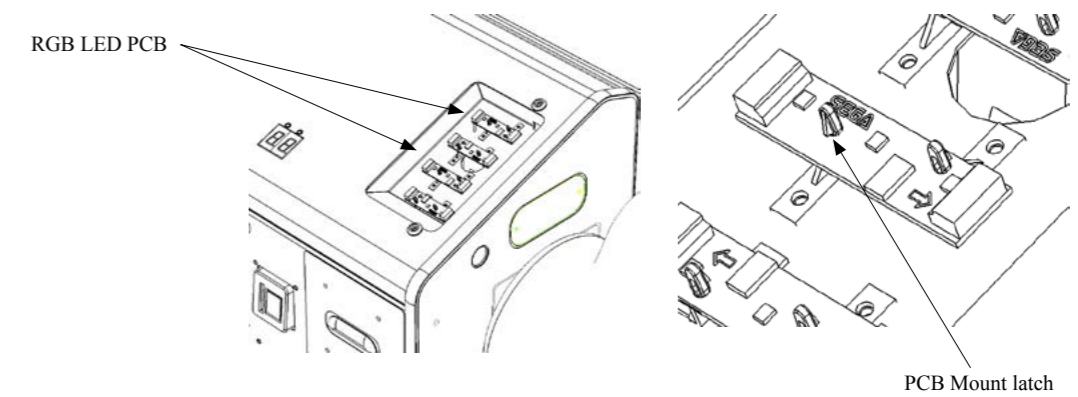

- 4** Clip the NEW LED into place and reconnect the harness (taking note of the orientation IN/OUT)

- 5** Follow steps 1 to 3 in reverse order to reassemble.

14 PERIODIC INSPECTION

The items listed below require periodic check and maintenance to retain the performance of this machine and to ensure safe business operation.

When handling the controller, the player will be in direct contact with it. In order to always allow the player to enjoy the game, be sure to clean it regularly. Also, it is advisable to provide wet tissue, etc. available for player use.

WARNING

- Every 6 months check to see if power cords are damaged, the plug is securely inserted, dust is accumulated between the socket outlet and the power plug, etc. Dust will accumulated if using the product regularly. Continued use with the presence of accumulated dust may result in a fire and or electric shock.
- There is the danger of accidents involving electrical shorts circuits or fire caused by factors such as the deterioration of insulation in electrical and electronic equipment over time. Check that there are no abnormalities such as odors from burning.
- For all normal maintenance procedures, always turn off the power before beginning. Starting the procedures with the power still on can result in electric shocks or short circuits.
- Do not use a water jet (high pressure washing device) or hose to clean this product. It was not designed to be cleaned by a water jet. Water could get inside and cause electrocution or short circuits. The product could also be damaged in such a way that it is difficult to repair.

CAUTION

- Be careful not to get your fingers caught when opening/closing or attaching/removing doors, lids and other such parts.
- When working inside the cabinet, you could get caught on parts or scratch yourself on them. Check the inside of the cabinet and be aware of where the parts are before performing the work.

Cleaning the Cabinet Surfaces

When the cabinet surfaces are badly soiled, remove stains with a soft cloth dipped in water or diluted with a chemical detergent and squeezed dry. To avoid damaging surface finish, do not use such solvents as thinner, benzine, etc. other than ethyl alcohol, or abrasives, bleaching agent and chemical dustcloth.

Some general-purpose household, kitchen and furniture cleaning products may contain strong solvents that degrade plastic components, coatings, and print. Before using any cleaning product, read the product's cautionary notes carefully and test the product first on a small area that is not highly visible.

IMPORTANT

Isopropyl Alcohol is a flammable liquid.

Do not use this cleaner near an exposed flame or clean the screen when it is powered on..

PERIODIC INSPECTION TABLE

| PERIOD | ITEMS | DESCRIPTION |
|----------------|---------------------|---------------------------------|
| As appropriate | CABINET SURFACE | Cleaning |
| | LAMPS | Inspection |
| Daily | CABINET | Confirm adjusters contact floor |
| | | Confirm stability |
| Weekly | FEATURE REEL | Check rotation |
| | | Check alignment |
| | TICKET DISPENSER | Check Operation |
| | | Check Ticket Total |
| Monthly | CONTROLLER | Inspect volume pots/Calibrate |
| | COIN SELECTOR | Coin switch inspection |
| | | Coin insertion test |
| | RED ONE (UN COCH) | Settings check |
| Every 3 Months | CONTROLLER | Apply grease |
| | TICKET DISPENSER | Cleaning |
| | COIN SELECTOR | Cleaning |
| | FEATURE REEL | Check Illumination |
| | AUDIO | Check Output |
| 1 year | RED ONE (UN COCH) | Cleaning |
| | POWER PLUG | Inspection, Cleaning |
| | FRONT CABI INTERIOR | Cleaning |

15 TROUBLESHOOTING

11-1 TROUBLESHOOTING (WHEN NO ERROR MESSAGE IS SHOWN)

⚠ WARNING

- In order to prevent electric shock and short circuit, be sure to turn power off before performing work.
- Be careful so as not to damage wirings. Damaged wiring can cause electric shock or short circuit.
- After removing the cause of the functioning of the Circuit Protector, reinstate the Circuit Protector. Depending on the cause of the functioning, using the Circuit Protector as is without removing the cause can cause generation of heat and fire hazard.
- In the event that a problem cannot be resolved by employing the procedures listed in this Manual, be sure to request service from the office shown on this Manual or the dealer from whom the product was originally purchased. Attempts to employ procedures other than those specified in this Manual can cause electrical shock, shorting, or fire.
- In the event of a problem that is not described here, be sure to contact the office shown on this Manual or the dealer from whom the product was originally purchased. Careless attempts at repair can result in electrical shock, shorting, or fire.

Replacing Fuses

⚠ WARNING

- In case fuse replacements other than those stated in this manual are necessary, contact where you purchased the product from for inquiries regarding this matter.
- In order to prevent an electric shock, be sure to turn power off and unplug from the socket outlet before performing work by touching the internal parts of the product.
- Be careful so as not to damage wirings. Damaged wiring can cause electric shock and short circuit accidents.
- Be sure to use fuses meeting specified rating. Using fuses exceeding the specified rating can cause fire and electric shock accidents.
- After eliminating the cause of the blowing of fuse, replace the fuse. Depending on the cause of fuse blowing, continued use with the fuse as is blown can cause generation of heat and fire hazard.

⚠ WARNING

- This work should be performed by site maintenance personnel or other skilled professionals. Work performed by non-technical personnel may cause a severe accident such as electric shock. If there are no site maintenance personnel or other skilled professionals available, turn the power off immediately and contact the office given in this manual or from the point of purchase.
- When working with the product, be sure to turn the power off. Working with the power on may cause an electric shock or short circuit.
- Be careful not to damage any wires whilst working on this product. Be aware when closing doors or fitting panels as wires may become trapped. Damaged wires can cause electric shock, short circuit or fire hazard.
- If problems other than those covered in this manual arise, or if no improvements can be noted after measures given in this manual have been taken, do not take measures discriminately. Remove power from the product immediately and contact the office shown in this manual or point of purchase. Indiscriminate countermeasures could lead to unforeseeable accidents. They could also result in permanent damage. Also, if the power is left on while there is an abnormality, a fire, electric shock or other serious accident may occur.

STOP IMPORTANT

- If an error message is displayed, identify the cause right away and take the appropriate countermeasures. Leaving the error unaddressed could result in a breakdown.
- If a problem occurs, first inspect the connection of any wiring connectors.
- Static electricity from your body may damage some electronics devices on the IC board. Before handling the IC board, touch a grounded metallic surface so that the static electricity can be discharged.

| PROBLEM | CAUSE | COUNTERMEASURE |
|---|---|---|
| With main switch ON there is no activation | Power is not supplied | Insert power lead all the way into outlet |
| | Supply voltage is not correct | Make sure that supply voltage is correct |
| | Circuit protector activated | Reset circuit protector/replace fuse |
| There is sound and lighting but no led Display | LED signal connector is not properly connected | Check connections of the LED and RedOne connector |
| No sound | Volume not properly adjusted | Adjust volume |
| | Poor connection of connectors | Check connections of RedOne |
| | Board, amp or speaker fault | Run speaker test to check. |
| Switch and volume pot input does not work | Poor connection or connectors | Check the connection to RedOne |
| Feature Reel does not spin | Poor connection to motor | check the connections to the Motor |
| | Poor connection on RedOne | Check connections of motor harness to RedOne |
| No operation, just a few static lamps lit | Poor condition of cabinet | Refer to list of errors |
| | RedOne error | Contact point of purchase |
| Controller does not work properly | Improper controller settings | Configure settings in TEST mode |
| | Poor attachment of volume pots or misalignment of gears | Adjust volume pot and set in calibration settings |
| | Poor connection of connectors | Check volume pot connections |
| | Volume pot failure | Replace volume pot |
| Game plays but lamp sequencing and Reel numbers do not correspond | Wheel alignment incorrect | Realign Reel using Test Menu |
| | Power to redOne inconsistent | Check DC5V supply at RedOne |
| | Connections to RedOne made incorrectly | Check connections against manual diagram. |
| No ticket payout | Poor connections at ticket dispenser | Check connections at ticket dispenser |
| | Poor connections at RedOne | Check connections at RedOne |
| | Possible faulty Ticket dispenser | Swap ticket dispenser over from left to right to fault find |
| | Ticket Jam | Clear ticket debris from ticket exit point. |

16 GAME BOARD

WARNING

- When working with the product, be sure to turn the power off. Working with the power on may cause an electric shock or short circuit.
- Be careful not to damage the wires. Damaged wires may cause an electric shock, short circuit or present a risk of fire.
- Do not use this product with connectors other than those that were connected and used with the game board at the time of shipping. Do not carelessly connect wires to connectors that were not used at the time of shipping, as this may cause overheating, smoke or fire damage.

CAUTION

In this product, setting changes are made during the test mode. The game board need not be operated. Use the game board, etc. as is with the same setting made at the time of shipment so as not to cause electrical damage or malfunction.

IMPORTANT

Static electricity from your body may damage some electronics devices on the IC board. Before handling the IC board, touch a grounded metallic surface so that the static electricity can be discharged.

16-1 GAME BOARD - HANDLING PRECAUTIONS

⚠ WARNING

- To prevent electric shock or IC Board malfunctioning, be sure to turn off the power for the cabinet when installing or removing the IC Board.
- Extraneous matter such as dust on the IC Board can cause the IC Board to generate heat and result in a fire due to short circuit, etc. Ensure the IC Board surfaces are always kept clean.
- Keep the IC board well cooled. RINGWIDE is provided with ventilating fans. Do not block the air outlets of these fans. Also do not place anything closely to RINGWIDE. Failure to observe these instructions may cause an overheating and fire.
- Always follow the usage conditions from SEGA as well as the usage conditions for the cabinet you are using for RED ONE (UN COCH). Failure to do so may cause an overheating and fire.

STOP IMPORTANT

- Be sure to connect the IC Board and connectors completely. Insufficient insertion can damage IC Board, etc.
- For the IC Board circuit inspection, only the use of Logic Tester is permitted. The use of ordinary testers is not permitted as these can damage the IC Board.
- Do not subject the IC Board to static electricity when installing the IC Board in the cabinet or when connecting wire harness connectors to the IC Board.
- When soldering buttons, etc. to the wire harnesses, be sure to remove the wire harnesses from the IC Board so as not to subject the IC Board to heat.
- Some parts are the ones designed and manufactured not specifically for this product. The manufacturers may discontinue, or change the specifications of, such general-purpose parts. If this is the case, SEGA cannot repair or replace a failed product whether or not a warranty period has expired.

16-2 GAME BOARD - LOCATION & REMOVAL

⚠ WARNING

- When returning the game board after making repairs or replacements, make sure that there are no errors in the connection of connectors. Erroneous connections can lead to electrical shock, short circuits or fires.
- When connecting a connector, check the direction carefully. Connectors must be connected in only one direction. If indiscriminate loads are applied in making connections, the connector or its terminal fixtures could be damaged, resulting in electrical shock, short circuits or fires.

The machine is fitted with Game Board Unit and several other Ancillary Boards which are fitted inside the Display Cabinet. Each machine contains its own CPU. Only qualified Personnel should attempt to Service these Units and before gaining access to the machine, it should be isolated from the mains supply

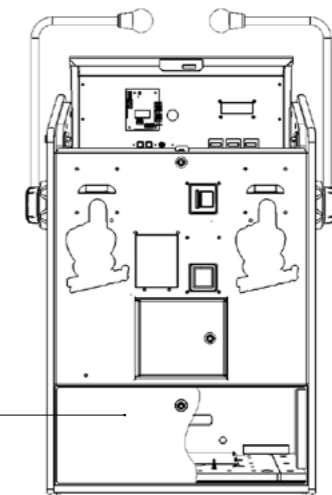

GAME BOARD SERVICE DOOR

There is only one access point to the GAME BD which is through the GAME BD SERVICE DOOR located at the front of the cabinet. Unlock the GAME BD SERVICE DOOR, the GAME BD is located directly behind the door. Pull out the draw to improve access.

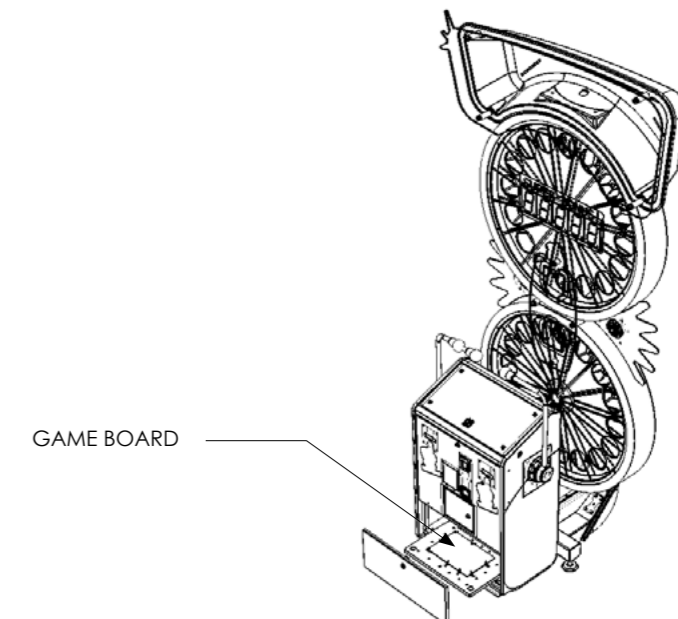

GAME BOARD

16-3 GAME BOARD - INTRODUCTION

The RED-M board is an arcade game controller capable of driving two simple cabinets at once. It contains a powerful ARM processor running at 100MHz and many peripherals, including:

- SD card for game software and data logging
- Audio amplifier for sound effects
- On-board EEPROM (4k x 8bits) for game logging
- 256 x LED array output (Multiplexed as 32 c.c. sinks x 8 rows)
- 16 x 2 Line LCD display interface with controlled backlight
- 2 x 7-segment 'Credit' LED display driver
- 4 x 7-segment 'Credit' LED display driver
- 4 x 6-wire stepper motor drives
- 4 x high current (1 Amp) switch outputs
- 32 x general purpose 500mA digital outputs (e.g. LED strip drives)
- 24 x general purpose digital inputs
- 8 x buffered analogue inputs, with 5V outputs for pots
- 1 x 100baseT Ethernet port
- 1 x 500Mbit/s CAN port
- 1 x RS232 port
- Controlled by a 100MHz 32-bit processor with an ARM M3 core
- JTAG port, bootstrap programming port.

To achieve the high channel count of inputs and outputs of the RED-M board, most peripherals to the microcontroller are implemented via I/O expanders driven over I2C busses.

Critical inputs and outputs (credit, vend, opto. sensors etc.) have dedicated connections directly to the processor.

16-4 GAME BOARD - PARTS DETAIL

LAYOUT

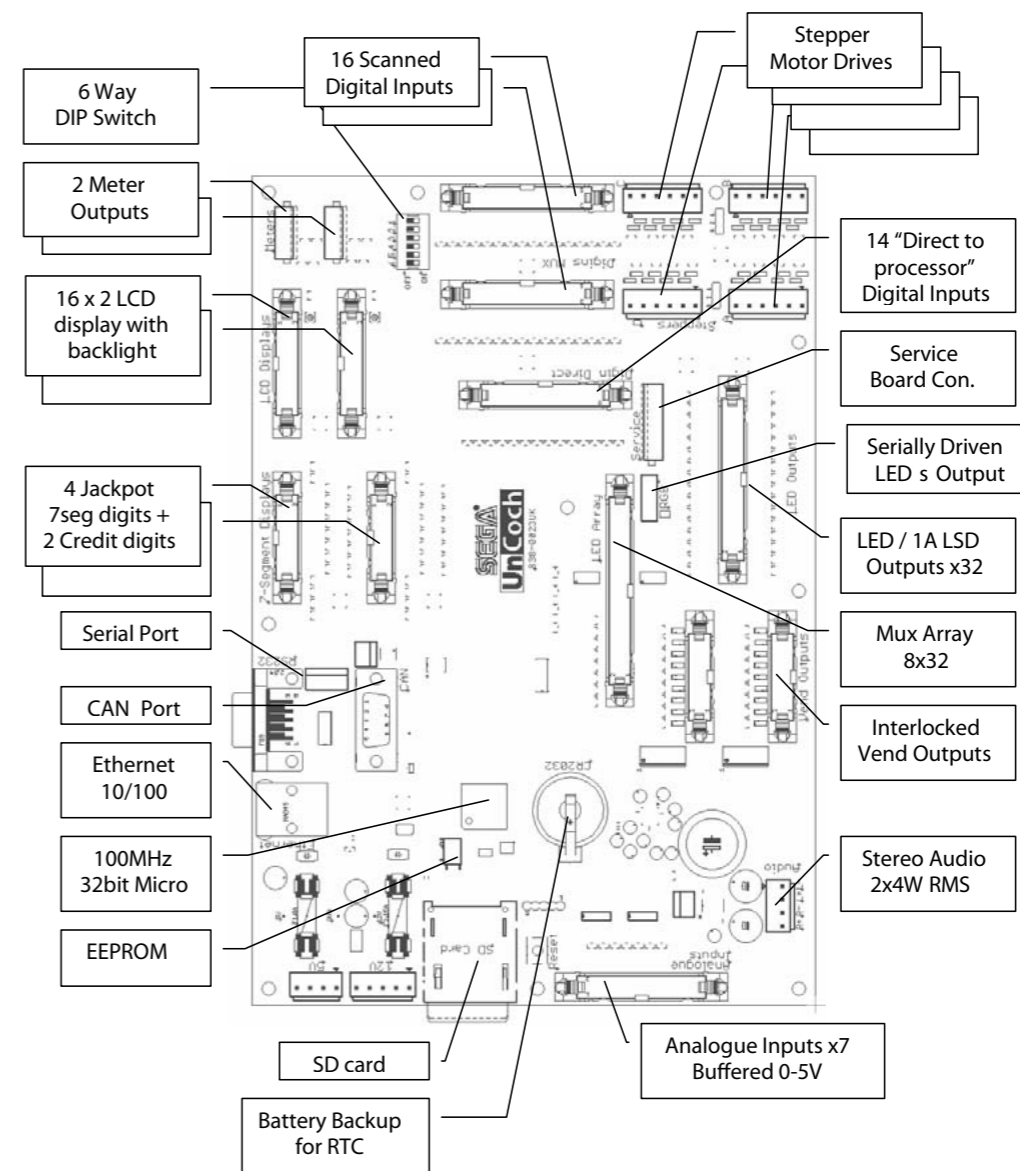

CONNECTORS, SWITCHES and LEDs

WARNING

- When connecting the connector, check the orientation and type carefully and connect securely. The connector must be connected in the proper direction and type. If it is connected in the wrong direction or indiscriminately at an incline, or connected wrong connector, so that a load is applied, the connector or its terminal pins could break, causing a short circuit or fire.
- Do not connect components to any connector that are not designated by SEGA. Connecting unspecified components could cause an accident such as an electric shock or fire.

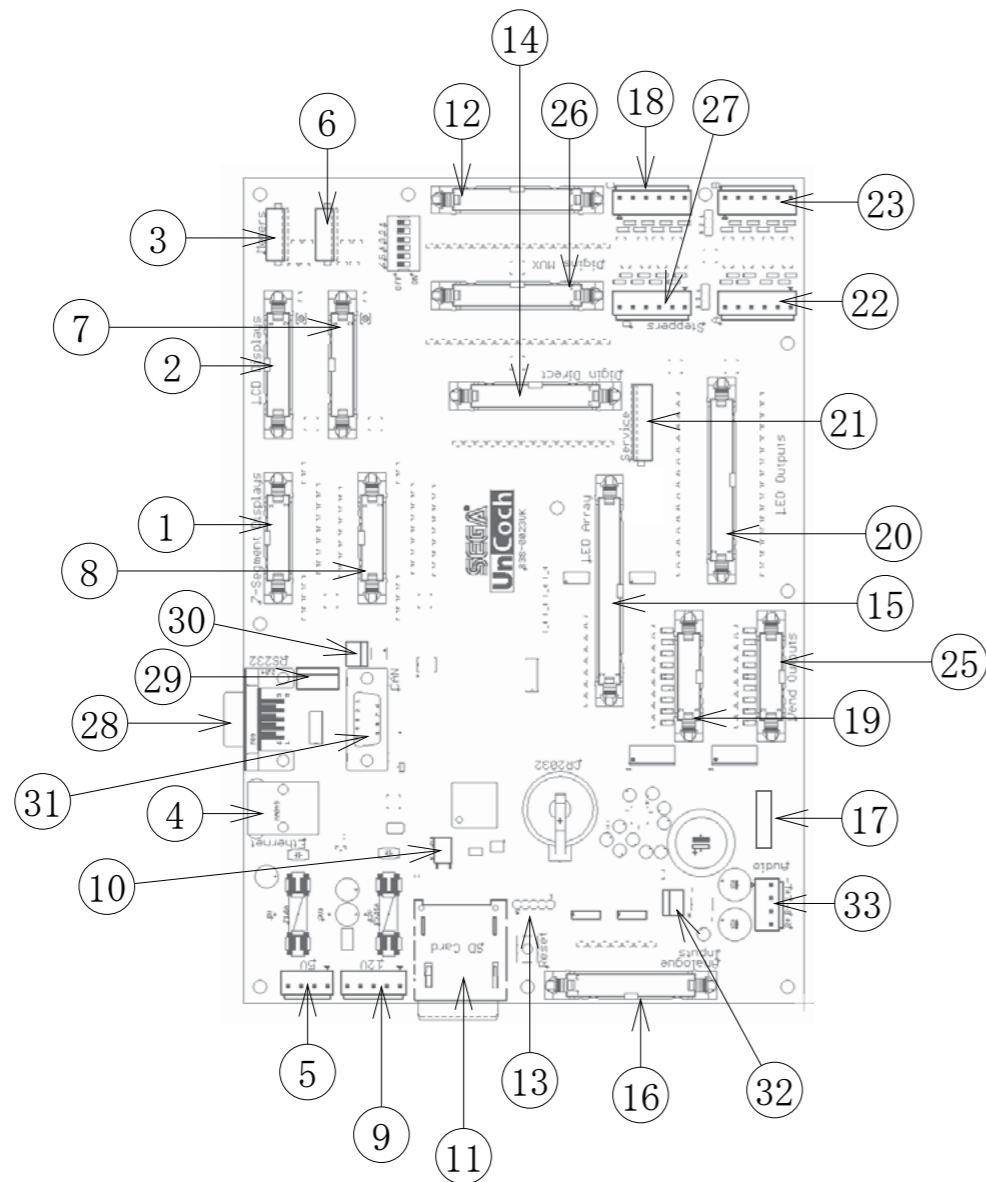

1 7 - Segment LED Display

| LOCATION | TYPE |
|----------|-----------------|
| J1 | 16W JST RA TYPE |

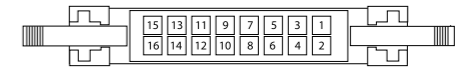

| Function | O/P | Pin | Pin | O/P | Function |
|----------------|-----|-----|-----|-----|---------------|
| A Credit UNITS | | 1 | 2 | | A Credit TENS |
| | | 3 | 4 | | |
| A SEG a | | 5 | 6 | | A SEG b |
| A SEG c | | 7 | 8 | | A SEG d |
| A SEG e | | 9 | 10 | | A SEG f |
| A SEG g | | 11 | 12 | | A SEG dp |
| A JP UNIT | | 13 | 14 | | A JP TENS |
| A JP HUND | | 15 | 16 | | A JP THOU |

NOTE: Before connecting, be sure to check the type of connector.

2 LCD Display

| LOCATION | TYPE |
|----------|-----------------|
| J2 | 20W JST RA TYPE |

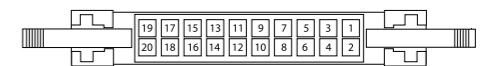

| Function | O/P | Pin | Pin | O/P | Function |
|----------|-------|-----|-----|-------|----------|
| | GND | 1 | 2 | GND | |
| | GND | 3 | 4 | GND | |
| V0 | | 5 | 6 | | RS |
| R/W | | 7 | 8 | | E |
| DB0 | | 9 | 10 | | DB1 |
| DB2 | | 11 | 12 | | DB3 |
| DB4 | | 13 | 14 | | DB5 |
| DB6 | | 15 | 16 | | DB7 |
| | LED + | 17 | 18 | LED - | |
| | 5V | 19 | 20 | GND | |

3 Counters / Meters

| LOCATION | TYPE |
|----------|-----------|
| J3 | 6W JST NH |

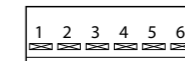

| Function | O/P | Pin |
|----------------------|---------|-----|
| | +12V | 1 |
| | +5V | 2 |
| GAMES | Meter 0 | 3 |
| TICKETS | Meter 1 | 4 |
| Spare Open Collector | Spare_0 | 5 |
| Spare Open Collector | Spare_1 | 6 |

4 Ethernet

| LOCATION | TYPE |
|----------|------|
| J4 | RJ45 |

| Function | O/P | Pin |
|----------|-----|-----|
| TD + | | 1 |
| TCT | | 2 |
| TD - | | 3 |
| RD + | | 4 |
| RCT | | 5 |
| RD - | | 6 |
| NC | | 7 |
| C_GND | | 8 |

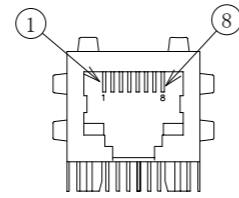

5 Power

| LOCATION | TYPE |
|----------|-----------|
| J5 | 4W JST VH |

| Function | O/P | Pin |
|----------|-----|-----|
| +5V | | 1 |
| +5V | | 2 |
| 0V | | 3 |
| 0V | | 4 |



6 Counters / Meters

| LOCATION | TYPE |
|----------|-----------|
| J6 | 6W JST NH |

| Function | O/P | Pin |
|----------------------|---------|-----|
| | +12V | 1 |
| | +5V | 2 |
| Ticket #2 Meter | Meter 2 | 3 |
| Ticket #3 Meter | Meter 3 | 4 |
| Spare Open Collector | Spare_2 | 5 |
| Spare Open Collector | Spare_3 | 6 |

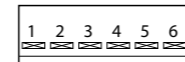

7 LCD Display

| LOCATION | TYPE |
|----------|-----------------|
| J7 | 20W JST RA TYPE |

| Function | O/P | Pin | Pin | O/P | Function |
|----------|-------|-----|-----|-------|----------|
| | GND | 1 | 2 | GND | |
| | GND | 3 | 4 | GND | |
| V0 | | 5 | 6 | | RS |
| R/W | | 7 | 8 | | E |
| DB0 | | 9 | 10 | | DB1 |
| DB2 | | 11 | 12 | | DB3 |
| DB4 | | 13 | 14 | | DB5 |
| DB6 | | 15 | 16 | | DB7 |
| | LED + | 17 | 18 | LED - | |
| | 5V | 19 | 20 | GND | |

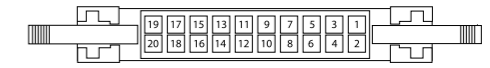

8 7 - Segment LED Display

| LOCATION | TYPE |
|----------|-----------------|
| J8 | 16W JST RA TYPE |

| Function | O/P | Pin | Pin | O/P | Function |
|----------------|-----|-----|-----|-----|---------------|
| B Credit UNITS | | 1 | 2 | | B Credit TENS |
| | | 3 | 4 | | |
| B SEG a | | 5 | 6 | | B SEG b |
| B SEG c | | 7 | 8 | | B SEG d |
| B SEG e | | 9 | 10 | | B SEG f |
| B SEG g | | 11 | 12 | | B SEG dp |
| B JP UNIT | | 13 | 14 | | B JP TENS |
| B JP HUND | | 15 | 16 | | B JP THOU |

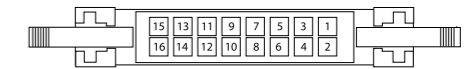

9 Power

| LOCATION | TYPE |
|----------|-----------|
| J9 | 5W JST VH |

| Function | O/P | Pin |
|----------|-----|-----|
| +12V | | 1 |
| +12V | | 2 |
| - | | 3 |
| 0V | | 4 |
| 0V | | 5 |

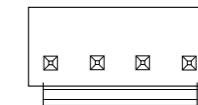

10 NOT USED

| LOCATION | TYPE |
|----------|------|
| J10 | N/A |

11 SD CARD READER FAT16

| LOCATION | TYPE |
|----------|-----------|
| J11 | 4W JST VH |

| Function | O/P | Pin |
|-----------------|-----|-----|
| CS | | 1 |
| DATA IN (MOSI) | | 2 |
| GND | | 3 |
| PWR | | 4 |
| CLK (SCLK) | | 5 |
| GND | | 6 |
| DATA OUT (MOSO) | | 7 |
| N/C | | 8 |
| N/C | | 9 |

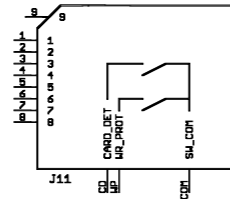

12 DIGITAL INPUTS MUX0-15

| LOCATION | TYPE |
|----------|-----------------|
| J12 | 26W JST RA TYPE |

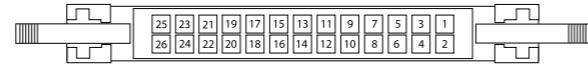

| Function | O/P | Pin | Pin | O/P | Function |
|----------|-------|-----|-----|-------|------------|
| PWR | +5V | 1 | 2 | +5V | PWR |
| START SW | MUX0 | 3 | 4 | MUX1 | UP SW |
| RIGHT SW | MUX2 | 5 | 6 | MUX3 | DOWN SW |
| GND | GND | 7 | 8 | GND | GND |
| LEFT SW | MUX4 | 9 | 10 | MUX5 | SW 1 |
| SW 2 | MUX6 | 11 | 12 | MUX7 | SW 3 |
| GND | GND | 13 | 14 | GND | GND |
| SW 4 | MUX8 | 15 | 16 | MUX9 | SW 5 |
| SW 6 | MUX10 | 17 | 18 | MUX11 | REFIL SW |
| GND | GND | 19 | 20 | GND | GND |
| TEST SW | MUX12 | 21 | 22 | MUX13 | SERVICE SW |
| DIP SW 1 | MUX14 | 23 | 24 | MUX15 | DIP SW 2 |
| PWR | +12V | 25 | 26 | +12V | PWR |

13 BOOT LOADER - DEV PURPOSES ONLY

| LOCATION | TYPE |
|----------|------------|
| J13 | 5W SIL HDR |

14 DIRECT DIGITAL INPUTS

| LOCATION | TYPE |
|----------|-----------------|
| J14 | 26W JST RA TYPE |

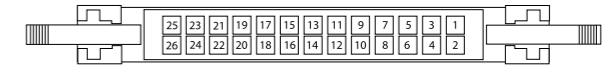

| Function | I/P | Pin | Pin | I/P | Function |
|--------------|-------|-----|-----|-------|--------------|
| 5V | | 1 | 2 | | 5V |
| GND | | 3 | 4 | | GND |
| COIN IN 1 | DID0 | 5 | 6 | DID1 | NOT USED |
| TICKET COUNT | DID2 | 7 | 8 | DID3 | TICKET COUNT |
| GND | | 9 | 10 | | GND |
| WHEEL SW T | DID4 | 11 | 12 | DID5 | NOT USED |
| WHEEL SW B | DID6 | 13 | 14 | DID7 | NOT USED |
| GND | | 15 | 16 | | GND |
| ENC TOP | DID8 | 17 | 18 | DID9 | ECN BOT |
| NOT USED | DID10 | 19 | 20 | DID11 | NOT USED |
| GND | | 21 | 22 | | GND |
| NOT USED | DID12 | 23 | 24 | DID13 | NOT USED |
| 12V | | 25 | 26 | | 12V |

15 LED MUX ARRAY

| LOCATION | TYPE |
|----------|-----------------|
| J15 | 40W JST RA TYPE |



| Function | Wire Code | Pin | Pin | Wire Code | Function |
|----------|-----------|-----|-----|-----------|----------|
| R0 | YEL/BLK | 1 | 2 | YEL/BRN | R1 |
| R2 | YEL/RED | 3 | 4 | YEL/ORG | R3 |
| R4 | YEL/BLU | 5 | 6 | YEL/PUR | R5 |
| R6 | YEL/GRY | 7 | 8 | YEL/WHT | R7 |
| C1 | BLU/BLK | 9 | 10 | BLU/BRN | C17 |
| C2 | BLU/RED | 11 | 12 | BLU/ORG | C18 |
| C3 | BLU/YEL | 13 | 14 | BLU/GRN | C19 |
| C4 | BLU/PUR | 15 | 16 | BLU/GRY | C20 |
| C5 | BLU/WHT | 17 | 18 | BLU/PNK | C21 |
| C6 | PUR/BLK | 19 | 20 | PUR/BRN | C22 |
| C7 | PUR/RED | 21 | 22 | PUR/ORG | C23 |
| C8 | PUR/YEL | 23 | 24 | PUR/GRN | C24 |
| C9 | PUR/BLU | 25 | 26 | PUR/GRY | C25 |
| C10 | PUR/WHT | 27 | 28 | PUR/PNK | C26 |
| C11 | GRY/BLK | 29 | 30 | GRY/BRN | C27 |
| C12 | GRY/RED | 30 | 32 | GRY/ORG | C28 |
| C13 | GRY/YEL | 32 | 34 | GRY/GRN | C29 |
| C14 | GRY/BLU | 34 | 36 | GRY/PUR | C30 |
| C15 | GRY/WHT | 36 | 38 | GRY/PNK | C31 |
| C16 | ? | 38 | 40 | ? | C32 |

16 ANALOGUE INPUTS

| LOCATION | TYPE |
|----------|-----------------|
| J16 | 26W JST RA TYPE |

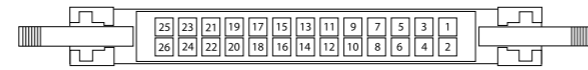

| Function | I/P | Pin | Pin | I/P | Function |
|--------------|-------|-----|-----|-------|------------|
| 5v | | 1 | 2 | | 5v |
| L/H Handle | AID 0 | 3 | 4 | AID 1 | R/H Handle |
| GND | | 5 | 6 | | GND |
| GND | | 7 | 8 | | GND |
| | AID 2 | 9 | 10 | AID 3 | |
| GND | | 11 | 12 | | GND |
| GND | | 13 | 14 | | GND |
| | AID 4 | 15 | 16 | AID 5 | |
| GND | | 17 | 18 | | GND |
| GND | | 19 | 20 | | GND |
| Audio Volume | AID 6 | 21 | 22 | AID 7 | |
| GND | | 23 | 24 | | GND |
| 12v | | 25 | 26 | | 12v |

17 RGB

| LOCATION | TYPE |
|----------|---------------|
| J17 | 6W JST PH K S |

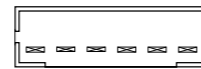

| Function | O/P | Pin |
|------------|-----|-----|
| RGB Latch | | 1 |
| RGB Data | | 2 |
| RGB CLK | | 3 |
| | GND | 4 |
| | +5V | 5 |
| LED SUPPLY | +5V | 6 |

18 MOTOR PORT C

| LOCATION | TYPE |
|----------|--------------------|
| J18 | 6W JST VH - VNR-6N |



| Function | O/P | Pin |
|----------|------------|-----|
| | STEPPER 8 | 1 |
| | 12v | 2 |
| | STEPPER 9 | 3 |
| | STEPPER 10 | 4 |
| | 12v | 5 |
| | STEPPER 11 | 6 |

19 7 - Segment LED Display

| LOCATION | TYPE |
|----------|-----------------|
| J19 | 16W JST RA TYPE |

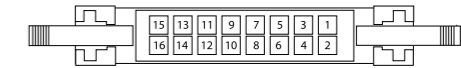

| Function | O/P | Pin | Pin | O/P | Function |
|----------------|--------|-----|-----|--------|----------------|
| Solenoid #2 | DLS_7 | 1 | 2 | 12v | External |
| Prize Vend #5 | DLS_8 | 3 | 4 | 12v | External |
| BOT Wheel C | DLS_9 | 5 | 6 | 12v | External |
| Ticket Vend #3 | DLS_10 | 7 | 8 | DHS_10 | Ticket Vend #3 |
| BOT Wheel D | DLS_11 | 9 | 10 | GND | |
| BOT Wheel L | DLS_12 | 11 | 12 | GND | |
| Ticket Vend #4 | DLS_13 | 13 | 14 | DHS_13 | Ticket Vend #4 |
| | GND | 15 | 16 | GND | |

20 Cabint and Switch LED Drives

| LOCATION | TYPE |
|----------|-----------------|
| J20 | 34W JST RA TYPE |

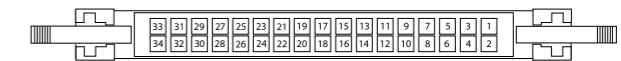

| Function | O/P | Pin | Pin | O/P | Function |
|---------------|-------|-----|-----|-------|----------|
| L/H CONT - R | LO 0 | 1 | 2 | LO 16 | |
| L/H CONT - G | LO 1 | 3 | 4 | LO 17 | |
| L/H CONT - B | LO 2 | 5 | 6 | LO 18 | |
| R/H CONT - R | LO 3 | 7 | 8 | LO 19 | |
| R/H CONT - G | LO 4 | 9 | 10 | LO 20 | |
| R/H CONT - B | LO 5 | 11 | 12 | LO 21 | |
| | LO 6 | 13 | 14 | LO 22 | |
| | LO 7 | 15 | 16 | LO 23 | |
| | LO 8 | 17 | 18 | LO 24 | |
| | LO 9 | 19 | 20 | LO 25 | |
| | LO 10 | 21 | 22 | LO 26 | |
| | LO 11 | 23 | 24 | LO 27 | |
| | LO 12 | 25 | 26 | LO 28 | |
| | LO 13 | 27 | 28 | LO 29 | |
| | LO 14 | 29 | 30 | LO 30 | |
| BILLBOARD - W | LO 15 | 31 | 32 | LO 31 | |
| | GND | 33 | 34 | GND | |

21 SERVICE

| LOCATION | TYPE |
|----------|-----------|
| J21 | 9W JST NH |

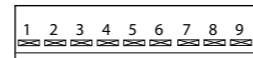

| Function | O/P | Pin |
|-------------|------|-----|
| | SW1 | 1 |
| | SW2 | 2 |
| | GND | 3 |
| | +5V | 4 |
| VOLUME CONT | | 5 |
| | GND | 6 |
| | +12V | 7 |
| COIN IN | | 8 |
| | GND | 9 |

22 MOTOR PORT A

| LOCATION | TYPE |
|----------|--------------------|
| J22 | 6W JST VH - VNR-6N |



| Function | O/P | Pin |
|----------|-----------|-----|
| | STEPPER 0 | 1 |
| | 12v | 2 |
| | STEPPER 1 | 3 |
| | STEPPER 2 | 4 |
| | 12v | 5 |
| | STEPPER 3 | 6 |

23 MOTOR PORT B

| LOCATION | TYPE |
|----------|--------------------|
| J23 | 6W JST VH - VNR-6N |

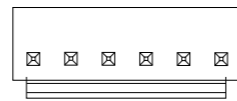

| Function | O/P | Pin |
|--------------|-----------|-----|
| TOP DC DRIVE | STEPPER 4 | 1 |
| | 12v | 2 |
| BOT DC DRIVE | STEPPER 5 | 3 |
| | STEPPER 6 | 4 |
| | 12v | 5 |
| | STEPPER 7 | 6 |

25 VEND OUTPUTS

| LOCATION | TYPE |
|----------|-----------------|
| J25 | 16W JST RA TYPE |

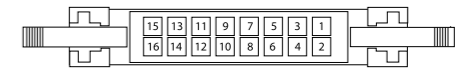

| Function | O/P | Pin | Pin | O/P | Function |
|----------------|--------|-----|-----|--------|----------------|
| Solenoid #2 | DLS_7 | 1 | 2 | 12v | External |
| Prize Vend #5 | DLS_8 | 3 | 4 | 12v | External |
| BOT Wheel C | DLS_9 | 5 | 6 | 12v | External |
| Ticket Vend #3 | DLS_10 | 7 | 8 | DHS_10 | Ticket Vend #3 |
| BOT Wheel D | DLS_11 | 9 | 10 | GND | |
| BOT Wheel L | DLS_12 | 11 | 12 | GND | |
| Ticket Vend #4 | DLS_13 | 13 | 14 | DHS_13 | Ticket Vend #4 |
| | GND | 15 | 16 | GND | |

26 DIGITAL INPUTS MUX16-31

| LOCATION | TYPE |
|----------|-----------------|
| J26 | 26W JST RA TYPE |



| Function | I/P | Pin | Pin | I/P | Function |
|----------|-------|-----|-----|-------|----------|
| +5V | | 1 | 2 | | +5V |
| DIGIN | MUX16 | 3 | 4 | MUX17 | DIGIN |
| DIGIN | MUX18 | 5 | 6 | MUX19 | DIGIN |
| GND | | 7 | 8 | | GND |
| DIGIN | MUX20 | 9 | 10 | MUX21 | DIGIN |
| DIGIN | MUX22 | 11 | 12 | MUX23 | DIGIN |
| GND | | 13 | 14 | | GND |
| DIGIN | MUX24 | 15 | 16 | MUX25 | DIGIN |
| DIGIN | MUX26 | 17 | 18 | MUX27 | DIGIN |
| GND | | 19 | 20 | | GND |
| DIGIN | MUX28 | 21 | 22 | MUX29 | DIGIN |
| DIGIN | MUX30 | 23 | 24 | MUX31 | DIGIN |
| +12V | | 25 | 26 | | +12V |

27 MOTOR PORT D

| LOCATION | TYPE |
|----------|--------------------|
| J27 | 6W JST VH - VNR-6N |

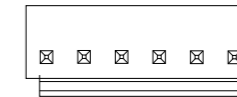

| Function | O/P | Pin |
|----------|------------|-----|
| | STEPPER 12 | 1 |
| | 12v | 2 |
| | STEPPER 13 | 3 |
| | STEPPER 14 | 4 |
| | 12v | 5 |
| | STEPPER 15 | 6 |

28 COMMS RS232

| LOCATION | TYPE |
|----------|------------------|
| J28 | 9W D Type Female |

| Function | O/P | Pin |
|----------|-----|-----|
| - | | 1 |
| RXD | | 2 |
| TXD | | 3 |
| - | | 4 |
| GND | | 5 |
| - | | 6 |
| RTS | | 7 |
| CTS | | 8 |
| - | | 9 |

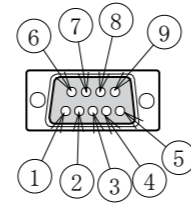

29 COMMS RS232

| LOCATION | TYPE |
|----------|-----------|
| J29 | 5W JST NH |

| Function | O/P | Pin |
|----------|-----|-----|
| RTS | | 1 |
| RXD | | 2 |
| TXD | | 3 |
| CTS | | 4 |
| GND | | 5 |

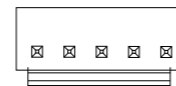

30 CAN PORT

| LOCATION | TYPE |
|----------|-----------|
| J30 | 3W JST NH |

| Function | O/P | Pin |
|----------|-----|-----|
| CAN1_H | | 1 |
| CAN1_L | | 2 |
| GND | | 3 |



31 CAN PORT

| LOCATION | TYPE |
|----------|------------------|
| J31 | 9W D Type Female |

| Function | O/P | Pin |
|----------|-----|-----|
| - | | 1 |
| CAN1_L | | 2 |
| - | | 3 |
| - | | 4 |
| GND | | 5 |
| GND | | 6 |
| CAN1_H | | 7 |
| - | | 8 |
| - | | 9 |

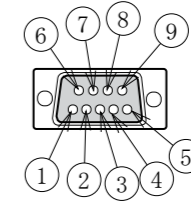

32 AUDIO BRIDGE

| LOCATION | TYPE |
|----------|-----------|
| J32 | 3W JST NH |

| Function | O/P | Pin |
|----------|-----|-----|
| BRIDGE | | 1 |
| NOT USED | | 2 |
| BRIDGE | | 3 |

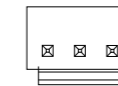

33 AUDIO

| LOCATION | TYPE |
|----------|-----------|
| J33 | 4W JST NH |

| Function | O/P | Pin |
|----------|-----|-----|
| SPKR L | | 1 |
| Common | | 2 |
| SPKR R | | 3 |
| Common | | 4 |



34 DIP SWITCH

| LOCATION | TYPE |
|----------|-----------|
| SW1 | 6W DIP SW |



Usage differs depending on game software. Set accordingly to the instructions given in this service manual under the section of TEST and DISPLAY DATA - DIP SWITCH SETTINGS

The factory settings when a game board (RedOne) is purchased as a stand alone unit

| No. 1 | No. 2 | No.3 | No. 4 | No. 5 | No. 6 |
|-------|-------|------|-------|-------|-------|
| OFF | OFF | OFF | OFF | OFF | OFF |

16-5 REPLACING THE BUTTON BATTERY

WARNING

- Make sure you do not damage the printed board and wires. Such damage can lead to electric shock, short circuit and fire hazard.
- To prevent overheating, explosion, or fire:
- Do not recharge, disassemble, heat, incinerate, or short the battery.
- Do not allow the battery to come into direct contact with metallic objects or other batteries.
- To preserve the battery, wrap it in tape or other insulating material.
- Follow local regulations when disposing of the battery. Improper disposal can damage the environment.
- Even the site maintenance personnel or other qualified professionals must not perform replacement operations for parts not described in this manual. In the event that such work is required either contact the office listed in this manual or first confirm the procedure with the place or office of purchase. Failure to do so may lead to electric shock or short circuit.
- Do not turn on the power with current carrying parts exposed. Doing so could result in electric shock or short circuit.

IMPORTANT

- The batteries in RedOne can be used for approximately 4 years of standard usage. If the battery appears to require replacement sooner than 4 years it is more likely that an error has occurred with some other part of the board. Rather than exchanging the battery requesting repair of the board itself may be more appropriate.
- Static electricity from your body may damage some electronics devices on the IC board. Before handling the IC board, touch a grounded metallic surface so that the static electricity can be discharged.
- To avoid risk of malfunction and damage:
 - Make sure the positive and negative ends are aligned correctly.
 - Use only batteries approved for use with this unit.

17 DESIGN-RELATED PARTS

For the warning display stickers, refer to Section 1.



18 PARTS LIST

TOP ASSY SEGA SNAKES & LADDERS BOM STRUCTURE

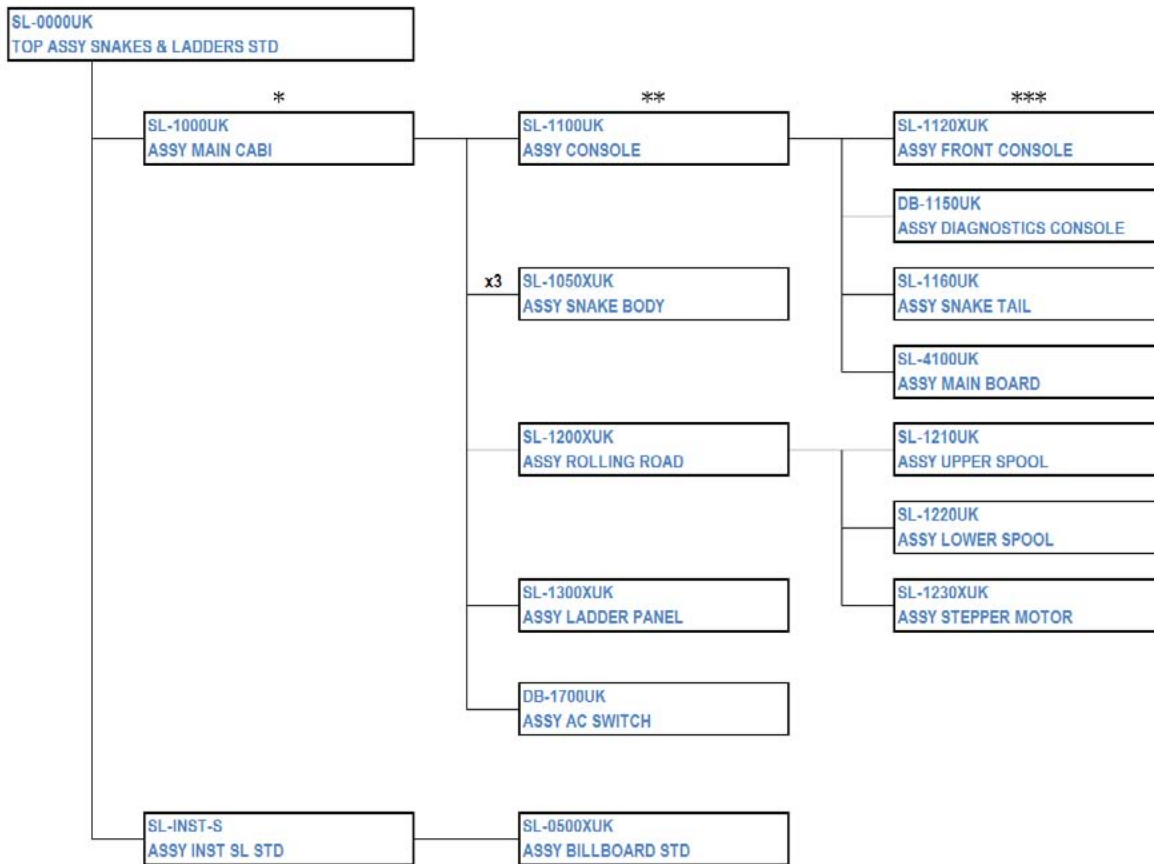

① ASSY TOP SNAKES & LADDERS (SL-0000UK)

(D-1/1)

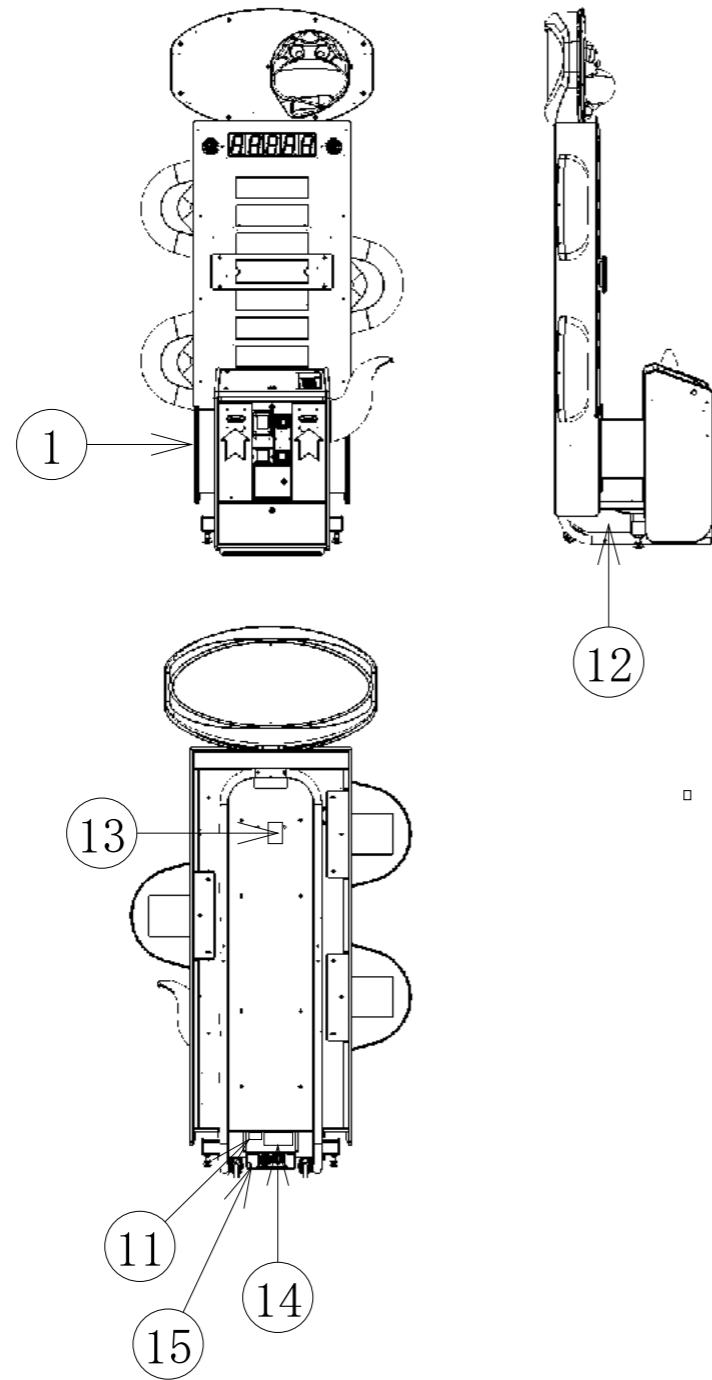

| ITEM NO | PART NUMBER | DESCRIPTION | QTY |
|---------|---------------|-------------------------------|-----|
| *1 | SL-1000UK | ASSY MAIN CABI | 1 |
| *11 | 421-7988-91UK | STICKER SERIAL NUMBER UK | 1 |
| *12 | 440-WS0010UK | LABEL WARNING HI-VOLTAGE | 2 |
| *13 | 440-WS0030UK | LABEL WARNING CAUTION | 2 |
| *14 | LB1046 | LABEL TESTED FOR ELEC. SAFETY | 1 |
| *15 | LB1130 | LABEL WEEE WHEELIE BIN | 1 |
| *401 | SL-INST-S | ASSY INST SL STD | 1 |
| *410 | | PALLET DB STD | 1 |
| *411 | | SHRINK WRAP DB STD | 1 |

② ASSY BILLBOARD (SL-0500XUK)

(D-1/1)

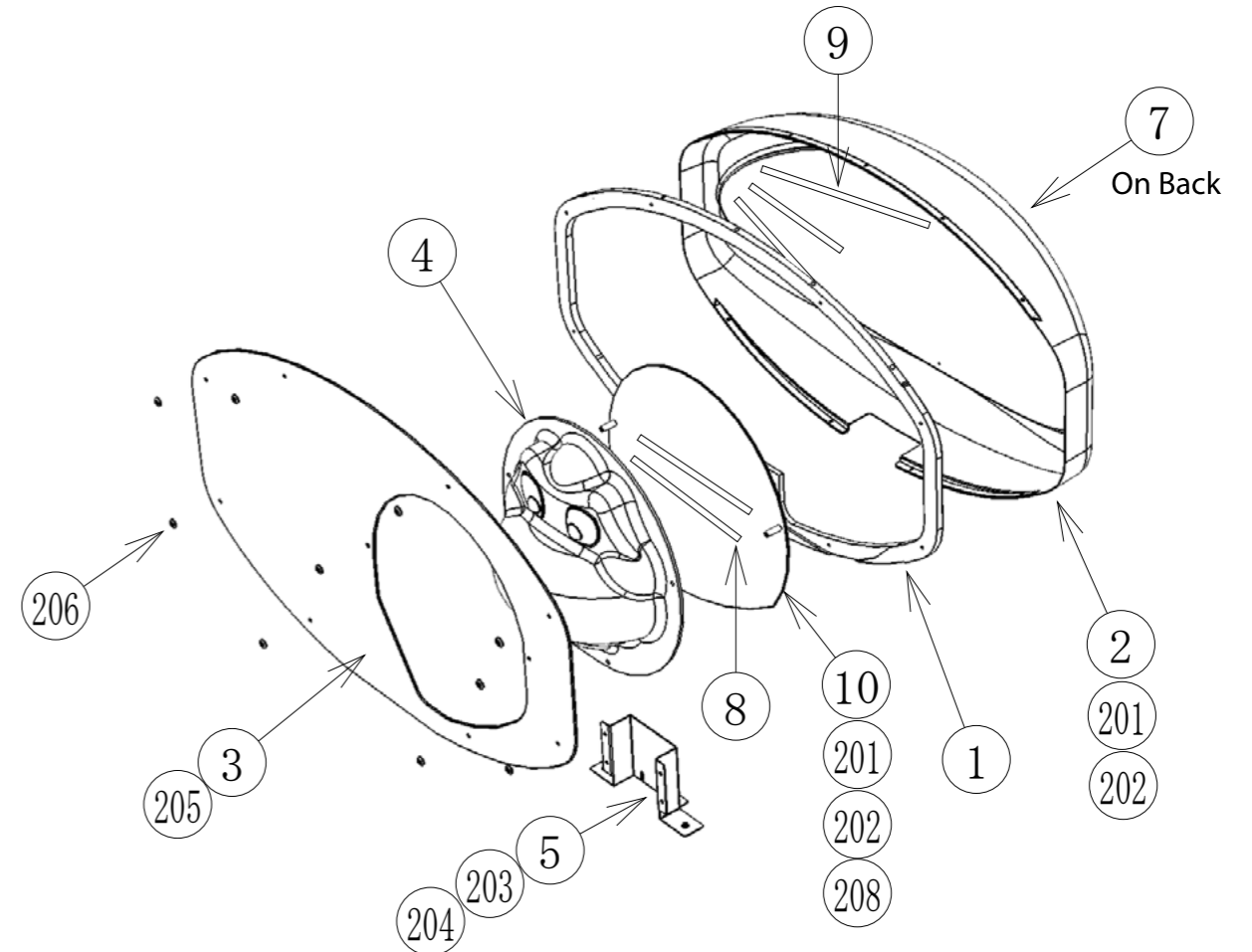

| ITEM NO | PART NUMBER | DESCRIPTION | QTY |
|---------|---------------|----------------------------|-----|
| ***1 | SL-0501XUK | BILLBOARD FRAME | 1 |
| ***2 | BE-0502UK | BILLBOARD HEADER | 1 |
| ***3 | SL-0503XUK | BILLBOARD COVER | 1 |
| ***4 | SL-0520XUK | SNAKE HEAD VAC | 1 |
| ***5 | SL-0507UK | BRKT BILLBOARD LOCATING | 1 |
| ***7 | SL-0505UK | HEADER INSERT | 1 |
| ***8 | SL-6005UK | ASSY LED RIGID WHITE 400 | 3 |
| ***9 | SL-6006UK | ASSY LED RIGID WHITE 520 | 2 |
| ***10 | SL-0508UK | PANEL SNAKE HEAD LED | 1 |
| ***201 | 008-0S0412 | M4X12 TMP PRF STN | 11 |
| ***202 | 068-441616 | M4 WSHR 16OD FLT PAS | 11 |
| ***203 | 030-000612-S | M6X12 BLT W/S PAS | 4 |
| ***204 | 068-652016 | M6 WSHR 20OD FLT PAS | 4 |
| ***205 | 080-B00420 | M4X20 TMP PRF BH PAS | 10 |
| ***206 | 280-6686-01UK | 4.5X16X4 SP WSHR | 10 |
| ***208 | 280-T41030-1 | PILLAR M4 TYPE 1 9.5OD 30L | 2 |
| ***301 | SL-60008UK | WH BILLBOARD | 1 |

③ ASSY MAIN CABINET (SL-1000UK)

(D-1/2)

③ ASSY MAIN CABINET (SL-1000UK)

(D-2/2)

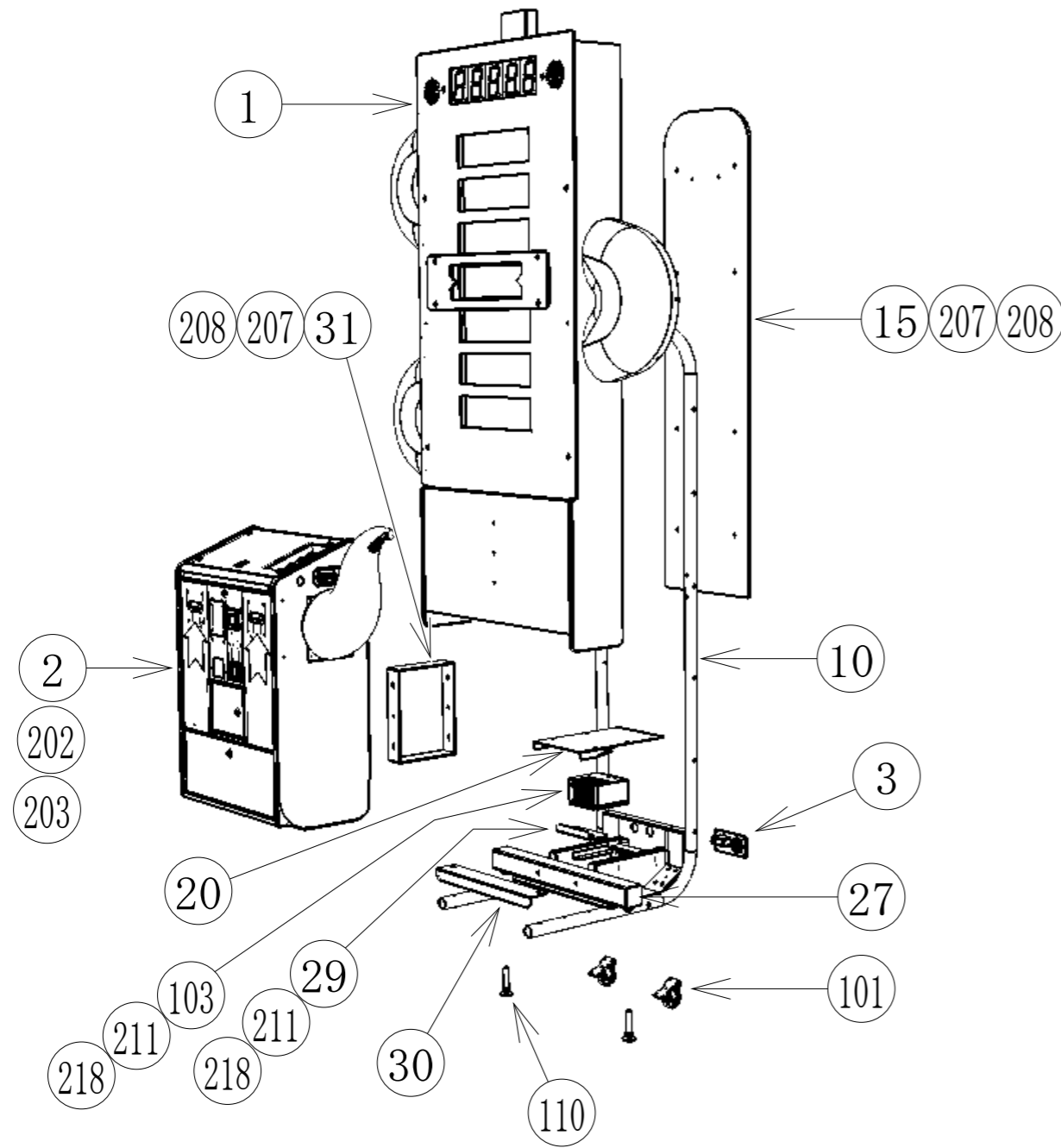

| ITEM NO | PART NUMBER | DESCRIPTION | |
|--------------|-------------------|--------------------------------|----------|
| **1 | SL-1001UK | ASSY SNAKE CABI | 1 |
| **2 | SL-1100UK | ASSY CONSOLE | 1 |
| **3 | DB-1700UK | ASSY AC UNIT | 1 |
| **10 | DB-1001XUK | FRAME MAIN | 1 |
| **15 | DB-1056UK | PANEL BACK | 1 |
| **20 | DB-1053UK | COVER PSU | 1 |
| **27 | DB-1051UK | FRAME SUB X MEMBER | 1 |
| **29 | DB-1061UK | BRKT RETAINER SETBACK PSU | 1 |
| **30 | DB-1058UK | BRKT FLOOR CLOSING | 1 |
| **31 | SL-1020UK | BRACE CABINET | 1 |
| **101 | | CASTOR KONTOOR 2.5" 63MM FIXED | 2 |
| **103 | 400-200-0512-M | PSU MULTI IN OUT 80-0002-10 | 1 |
| **109 | 280-A01264-WX | ROUTER TWIST D12 SO6.4 WOOD X | 20 |
| **110 | 601-5699UK-01 | LEG ADJUSTER M16X100 LNUT | 2 |
| **202 | 030-000850-S | M8X50 BLT W/S PAS | 6 |
| **203 | 068-852216 | M8 WSHR 22OD FLT PAS | 6 |
| **207 | 030-000830-SB | M8X30 BLT W/S BLK | 24 |
| **208 | 068-852216-OB | M8 WSHR 22OD FLT BLK | 24 |
| **211 | 068-441616-OB | M4 WSHR 16OD FLT BLK | 12 |
| **218 | 050-F00400 | M4 NUT FLG SER PAS | 4 |
| **301 | DB-60001UK | WH DC DISTRIBUTION | 1 |

④ ASSY SNAKE CABINET (SL-1001UK)

(D-1/2)

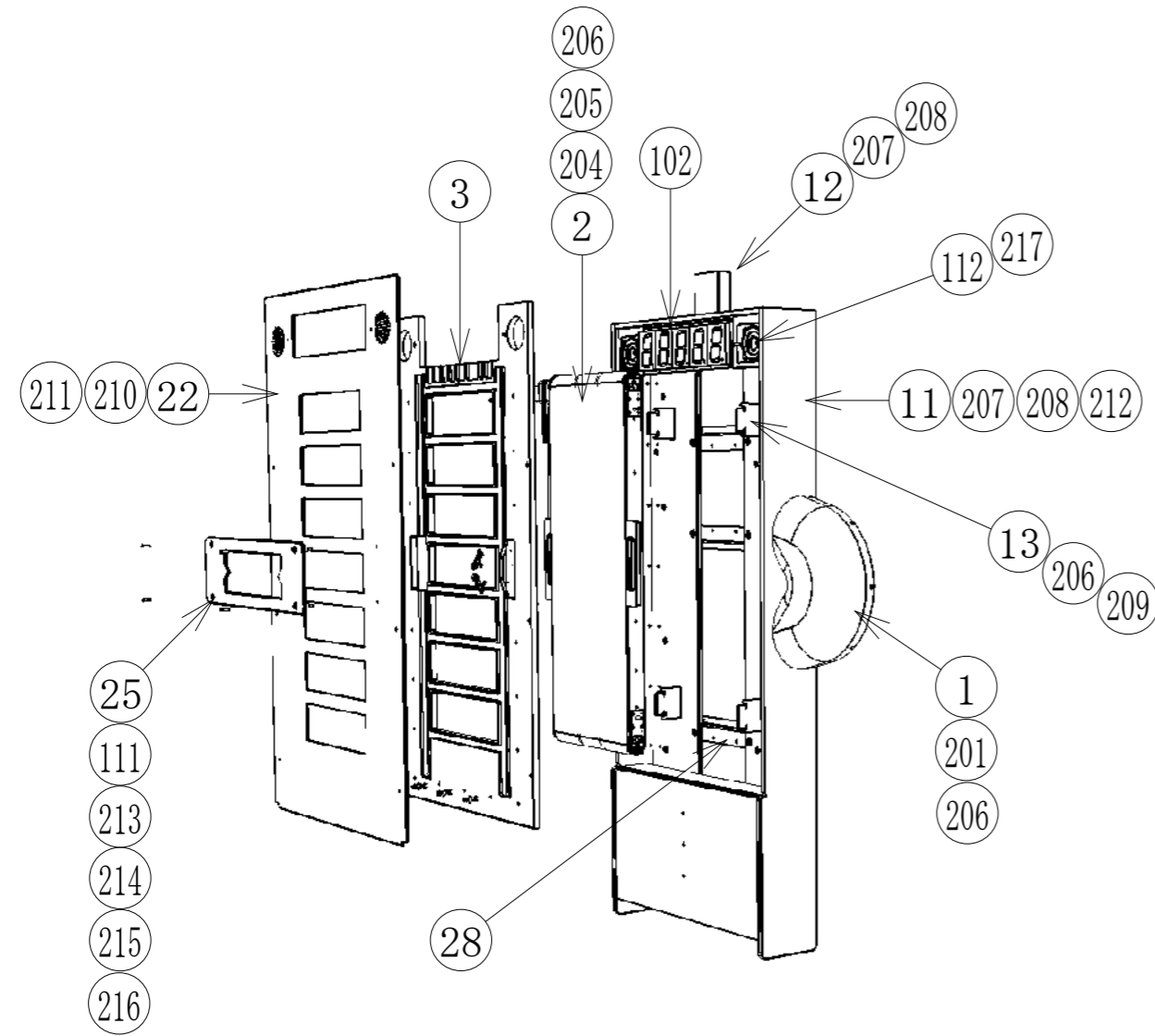

④ ASSY SNAKE CABINET (SL-1001UK)

(D-2/2)

| ITEM NO | PART NUMBER | DESCRIPTION | QTY |
|---------|---------------|-----------------------------|-----|
| **1 | SL-1050XUK | ASSY SNAKE BODY | 3 |
| **2 | SL-1200XUK | ASSY ROLLING ROAD | 1 |
| **3 | SL-1300XUK | ASSY LADDER PANEL | 1 |
| **11 | SL-1002UK | FRONT CABINET | 1 |
| **12 | SL-1003UK | BRKT BILLBOARD SUPPORT | 1 |
| **13 | SL-1004XUK | BRKT ROLLING ROAD MOUNT | 4 |
| **22 | SL-1012UK | FASCIA PANEL | 1 |
| **25 | SL-1015UK | WIN PANEL | 1 |
| **28 | DB-1052UK | BRACE DISC | 4 |
| **102 | 838-0024UK | PCBA-JACKPOT LED | 1 |
| **108 | 280-L01340-WX | STANDOFF 13MM WOOD | 4 |
| **111 | 280-T41030-1 | PILLAR M4 TYPE1 9.5OD 30L | 4 |
| **112 | 130-010-04020 | SPKR 4OHM 20W FR 10 HM 4898 | 2 |
| **201 | 030-000635-S | M6X35 BLT W/S PAS | 9 |
| **204 | 050-F00600 | M6 NUT FLG SER PAS | 4 |
| **205 | 060-S00600 | M6 WSHR SPR PAS | 4 |
| **206 | 068-652016 | M6 WSHR 20OD FLT PAS | 21 |
| **207 | 030-000830-SB | M8X30 BLT W/S BLK | 24 |
| **208 | 068-852216-OB | M8 WSHR 22OD FLT BLK | 24 |
| **209 | 030-000612-S | M6X12 BLT W/S PAS | 8 |
| **210 | 008-T00450-OB | M4X50 TMP PRF TH BLK | 6 |
| **211 | 068-441616-OB | M4 WSHR 16OD FLT BLK | 12 |
| **212 | 020-F00650-OB | M6X50 MSCR SKT CSK BLK | 6 |
| **213 | 008-B00416 | M4X16 TMP BH PAS | 4 |
| **214 | 280-6686-01UK | 4.5X16X4 SP WSHR | 4 |
| **215 | 000-P00416-W | M4X16 MSCR PAN W/FS PAS | 4 |
| **216 | 068-441616 | M4 WSHR 16OD FLT PAS | 4 |
| **217 | 000-P00410-W | M4X10 MSCR PAN W/FS PAS | 8 |
| **303 | SL-60001UK | WH STRUT A | 1 |
| **305 | DB-60022UK | WH JACKPOT CAN | 1 |
| **309 | SL-60003UK | WH LEDS SNAKE | 1 |
| **310 | SL-60004UK | WH SNAKE BODY | 1 |

④ ASSY SNAKE BODY (SL-1050XUK)

(D-1/1)

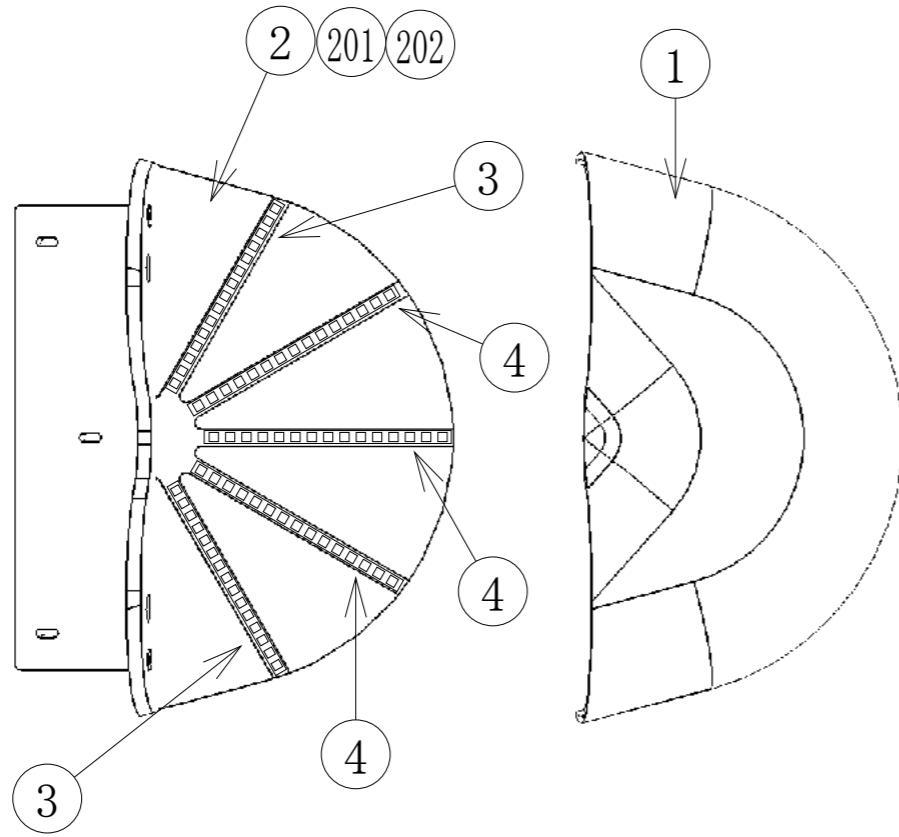

| ITEM NO | PART NUMBER | DESCRIPTION | QTY |
|---------|---------------|----------------------|-----|
| ***1 | SL-1051XUK | BASE SNAKE BODY | 1 |
| ***2 | SL-1052XUK | SNAKE BODY PANEL | 1 |
| ***3 | SL-6008UK | ASSY RIGID 160MM | 2 |
| ***4 | SL-6009UK | ASSY RIGID 200MM | 3 |
| ***201 | 000-T00416-OB | M4X16 MSCR TH BLK | 5 |
| ***202 | 068-441616-OB | M4 WSHR 16OD FLT BLK | 5 |

⑤ ASSY CONSOLE CABI (SL-1100UK)

(D-1/2)

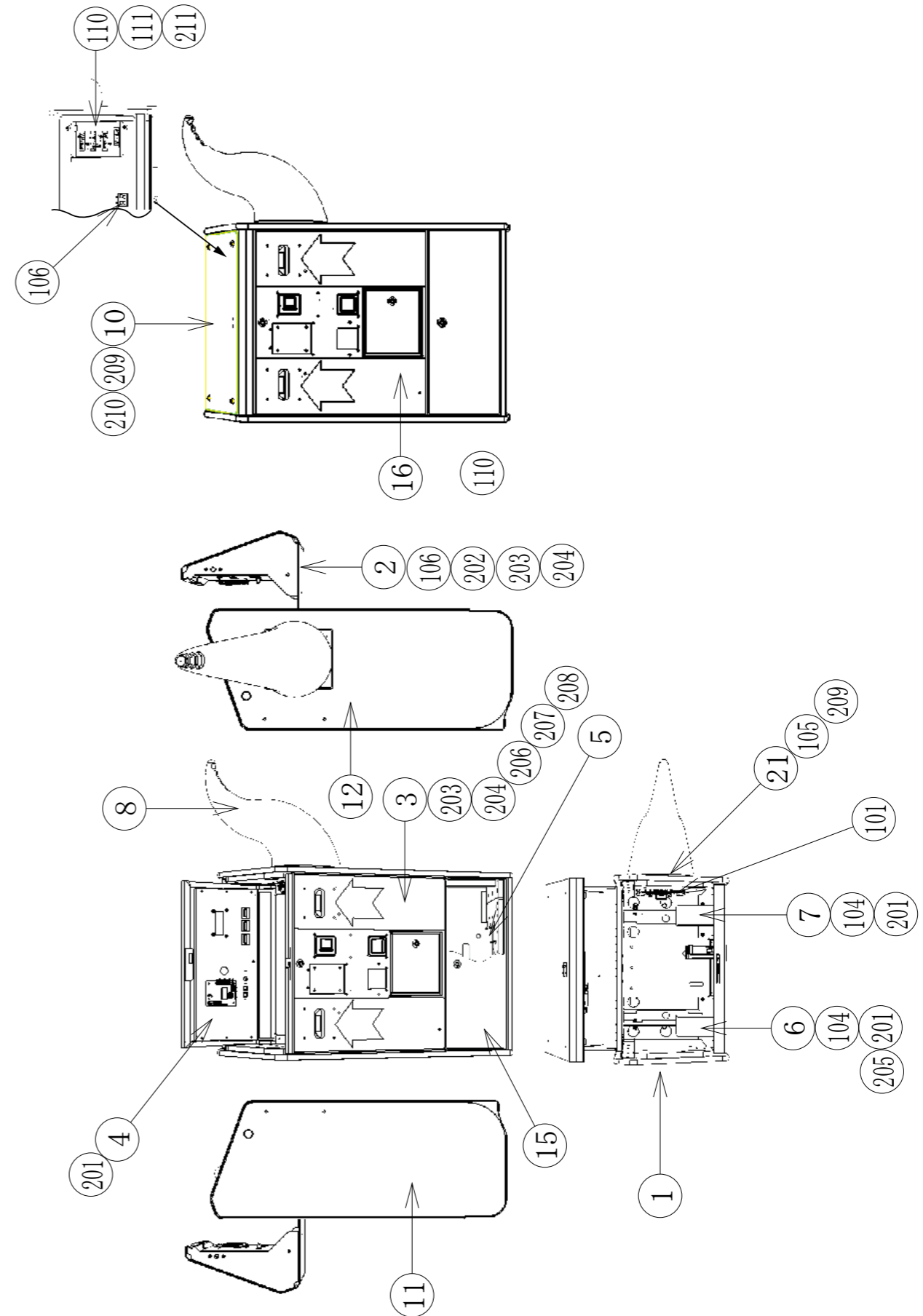

⑤ ASSY CONSOLE CABI (SL-1100UK)

(D-2/2)

| ITEM NO | PART NUMBER | DESCRIPTION | QTY |
|---------|---------------|-----------------------------------|-----|
| ***1 | SL-1101XUK | CONSOLE | 1 |
| ***2 | SL-1102UK | CONSOLE LID | 1 |
| ***3 | SL-1120XUK | ASSY FRONT CONSOLE | 1 |
| ***4 | DB-1150UK | ASSY DIAGNOSTICS CONSOLE | 1 |
| ***5 | SL-4100UK | ASSY MAIN BOARD | 1 |
| ***6 | DB-1105UK | HOLDER TICKET L | 1 |
| ***7 | DB-1106UK | HOLDER TICKET R | 1 |
| ***8 | SL-1160UK | ASSY SNAKE TAIL | 1 |
| ***10 | SL-1110UK | PLATE LID COVER | 1 |
| ***11 | SL-1111UK | STICKER CONSOLE L | 1 |
| ***12 | SL-1112UK | STICKER CONSOLE R | 1 |
| ***15 | SL-1115UK | STICKER CONSOLE DOOR MAIN BD | 1 |
| ***16 | SL-1116XUK | STICKER CONSOLE FRONT | 2 |
| ***21 | SL-1132UK | COVER TAIL LIGHT | 1 |
| ***101 | 601-0002-RXUK | MECHA-R ANALOGUE HAPP | 1 |
| ***102 | FN1012 | FAN GUARD METAL 120MM (FG-12) | 1 |
| ***104 | EP1820 | SW MICRO LEVER RS 7064281 | 2 |
| ***105 | EP1421 | LED 12V RED RS 5414072 | 2 |
| ***106 | EP1432 | LED 0.8" 7 SEG FEM-080220BGWT1 #M | 2 |
| ***108 | 280-A01264-WX | ROUTER TWIST D12 SO6.4 WOOD X | 8 |
| ***109 | 280-A02064-WX | ROUTER TWIST D20 SO6.4 WOOD X | 2 |
| ***110 | 838-0025UK | PCBA-RGB SERIAL | 4 |
| ***111 | OS1011 | PCB FEET RICHCO LCBS | 8 |
| ***201 | 000-P00410-W | M4X10 MSCR PAN W/FS PAS | 18 |
| ***202 | 031-000640-OB | M6X40 CRG BLT BLK | 5 |
| ***203 | 050-F00600 | M6 NUT FLG SER PAS | 15 |
| ***204 | 068-652016 | M6 WSHR 20OD FLT PAS | 13 |
| ***205 | 000-P00320 | M3X20 MSCR PAN PAS | 4 |
| ***206 | 030-000830-SB | M8X30 BLT W/S BLK | 4 |
| ***207 | 068-852216-OB | M8 WSHR 22OD FLT BLK | 4 |
| ***208 | 020-F00650-OB | M6X50 MSCR SKT CSK BLK | 4 |
| ***209 | 008-B00416 | M4X16 TMP BH PAS | 6 |
| ***210 | 280-6686-01UK | 4.5X16X4 SP WSHR | 4 |
| ***211 | 000-F00308 | M3X8 MSCR CSK PAS | 8 |
| ***301 | | | |
| ***302 | DB-60038UK | WH CONTROL PNL | 1 |
| ***303 | SL-60014UK | WH TAIL TO CTRL PANEL ILLUM | 1 |
| ***304 | SL-60015UK | WH CTRL PANEL ILLUM TO CABINET | 1 |
| ***305 | SL-60022UK | WH CONTROLLERS | 1 |

⑥ ASSY FRONT CONSOLE (SL-1120XUK)

(D-1/1)

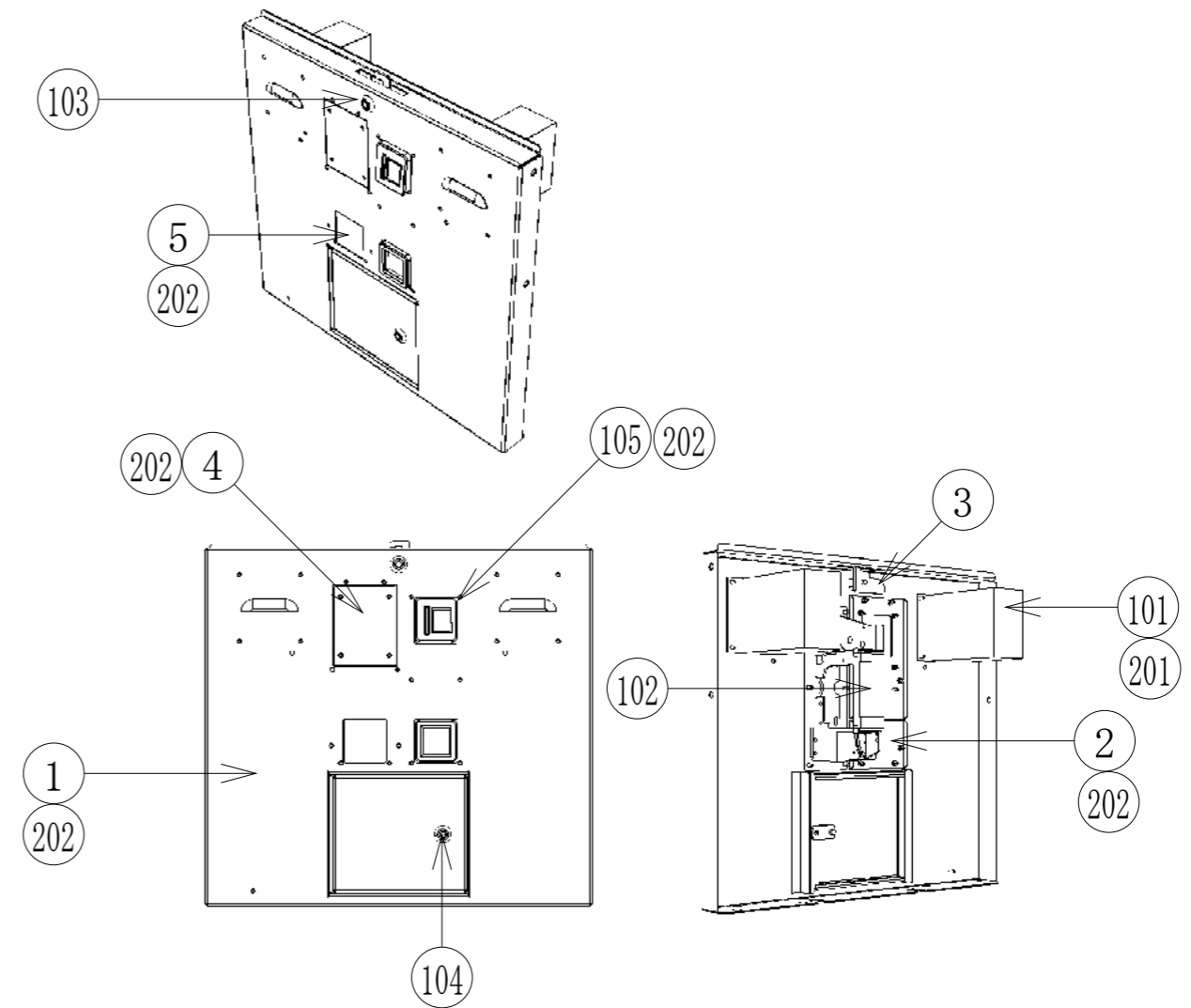

| ITEM NO | PART NUMBER | DESCRIPTION | QTY |
|---------|---------------|-------------------------------------|-----|
| ****1 | SL-1121XUK | FRONT CONSOLE | 1 |
| ****2 | SL-1122UK | BRKT DUAL MECH MOUNT | 1 |
| ****3 | DB-1123UK | TNG LID | 1 |
| ****4 | SL-1124UK | PLATE DBA DOWNSTACKER BLANK | 1 |
| ****5 | SL-1125UK | BRKT DUAL MECH REJECT BLANK | 1 |
| ****101 | 220-0001-01UK | TICKET VEND UNIT TD-963CR | 2 |
| ****102 | 220-5610-01 | COIN MECH SR3 | 1 |
| ****103 | 220-5575UK | LOCK (J9117) KEY TO LIKE 22MM W CAM | 1 |
| ****104 | 220-5574UK | LOCK KEYED DIFFERENT 7087-10 | 1 |
| ****105 | 220-5786-R | A0710 IL FRONT PLATE ROHS COMPLIANT | 1 |
| ****201 | 050-U00400 | M4 NUT NYLOK PAS | 8 |
| ****202 | 050-F00400 | M4 NUT FLG SER PAS | 19 |

⑦ ASSY DIAGNOSTICS CONSOLE (DB-1150UK) (D-1/1)

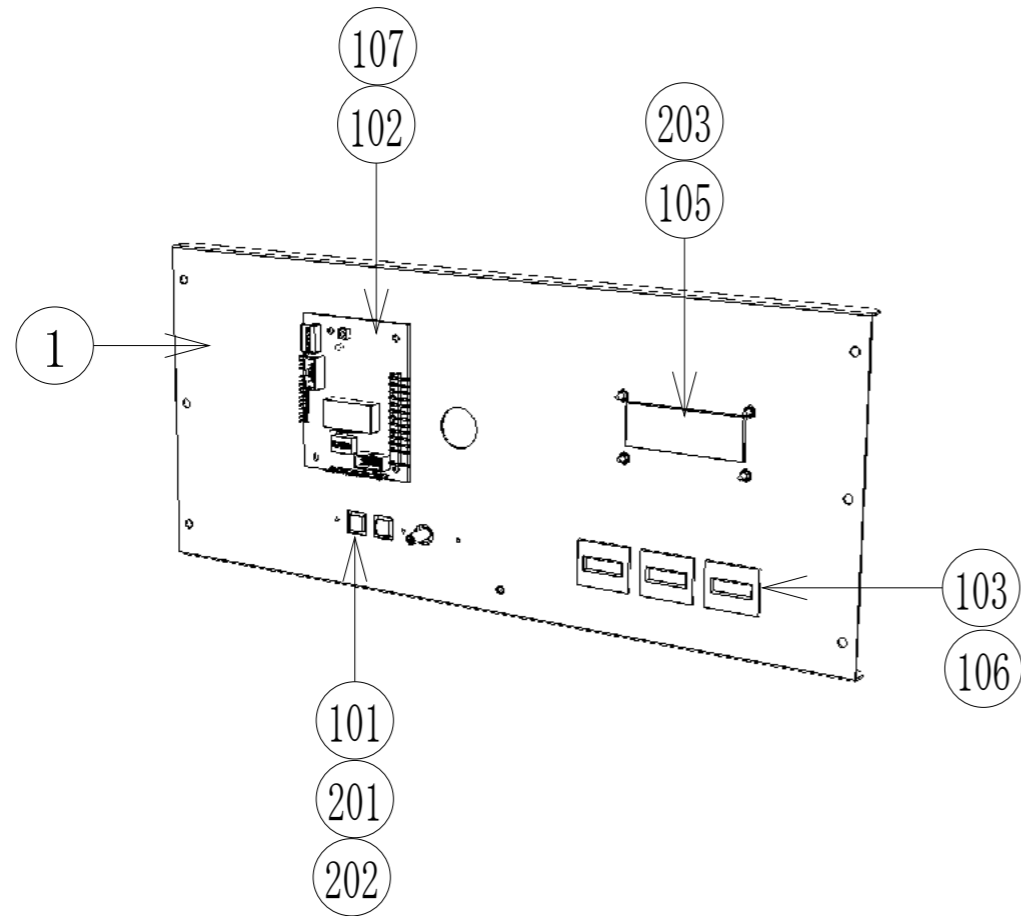

| ITEM NO | PART NUMBER | DESCRIPTION | QTY |
|---------|-----------------|------------------------|-----|
| ****1 | DB-1151UK | BRKT DIAGNOSTICS | 1 |
| ****101 | 838-14548-01AUK | SW & VOL CTL BD | 1 |
| ****102 | EP1380-01 | EXCEL CREDIT BOARD | 1 |
| ****103 | 220-5643UK | 12V COIN METER | 3 |
| ****105 | EP1429 | LCD MDL 2X16 PC1602LRS | 1 |
| ****106 | OS1098 | CRIMP BELL END SMALL | 6 |
| ****107 | 280-L00706-PM | STANDOFF 6.4MM HOLE PM | 4 |
| ****201 | 000-P00308 | M3X8 MSCR PAN PAS | 3 |
| ****202 | 068-330808-PN | M3 WSHR 8OD FLT NYLON | 11 |
| ****203 | 000-F02508 | M2.5X8 MSCR CSK BZ | 4 |

⑧ ASSY SNAKE TAIL (SL-1160UK) (D-1/1)

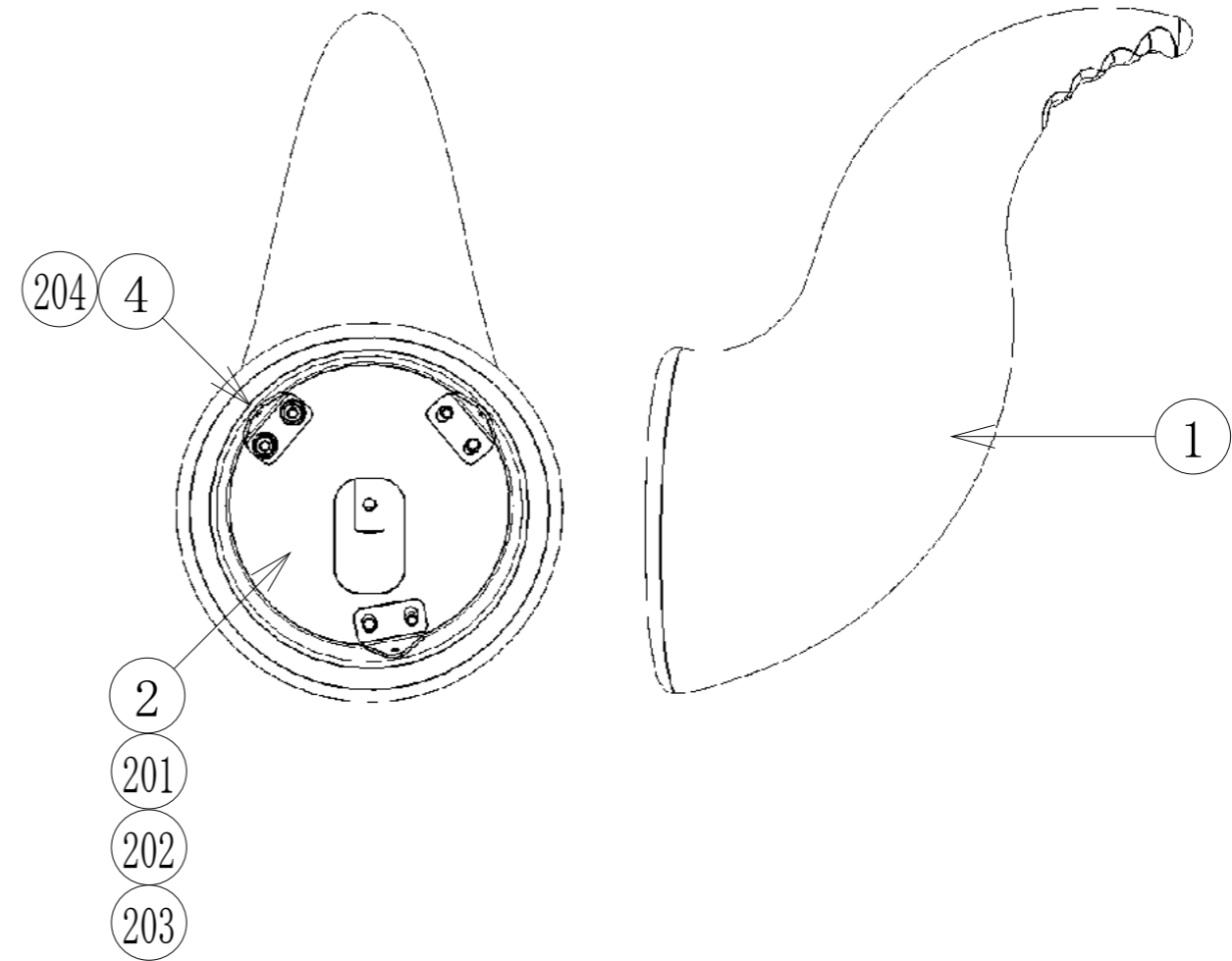

| ITEM NO | PART NUMBER | DESCRIPTION | QTY |
|---------|-------------|----------------------|-----|
| ***1 | SL-1161UK | TAIL SNAKE | 1 |
| ***2 | SL-1163UK | BRKT TAIL MOUNT | 1 |
| ***4 | SL-1164UK | BRKT TAIL SUPPORT | 3 |
| ***201 | 030-000612 | M6X12 BLT PAS | 3 |
| ***202 | 060-S00600 | M6 WSHR SPR PAS | 3 |
| ***203 | 068-652016 | M6 WSHR 20OD FLT PAS | 6 |
| ***204 | 050-U00600 | M6 NUT NYLOK PAS | 3 |

⑨ ASSY TRACKER / ROLLING ROAD (SL-1200XUK) (D-1/1)

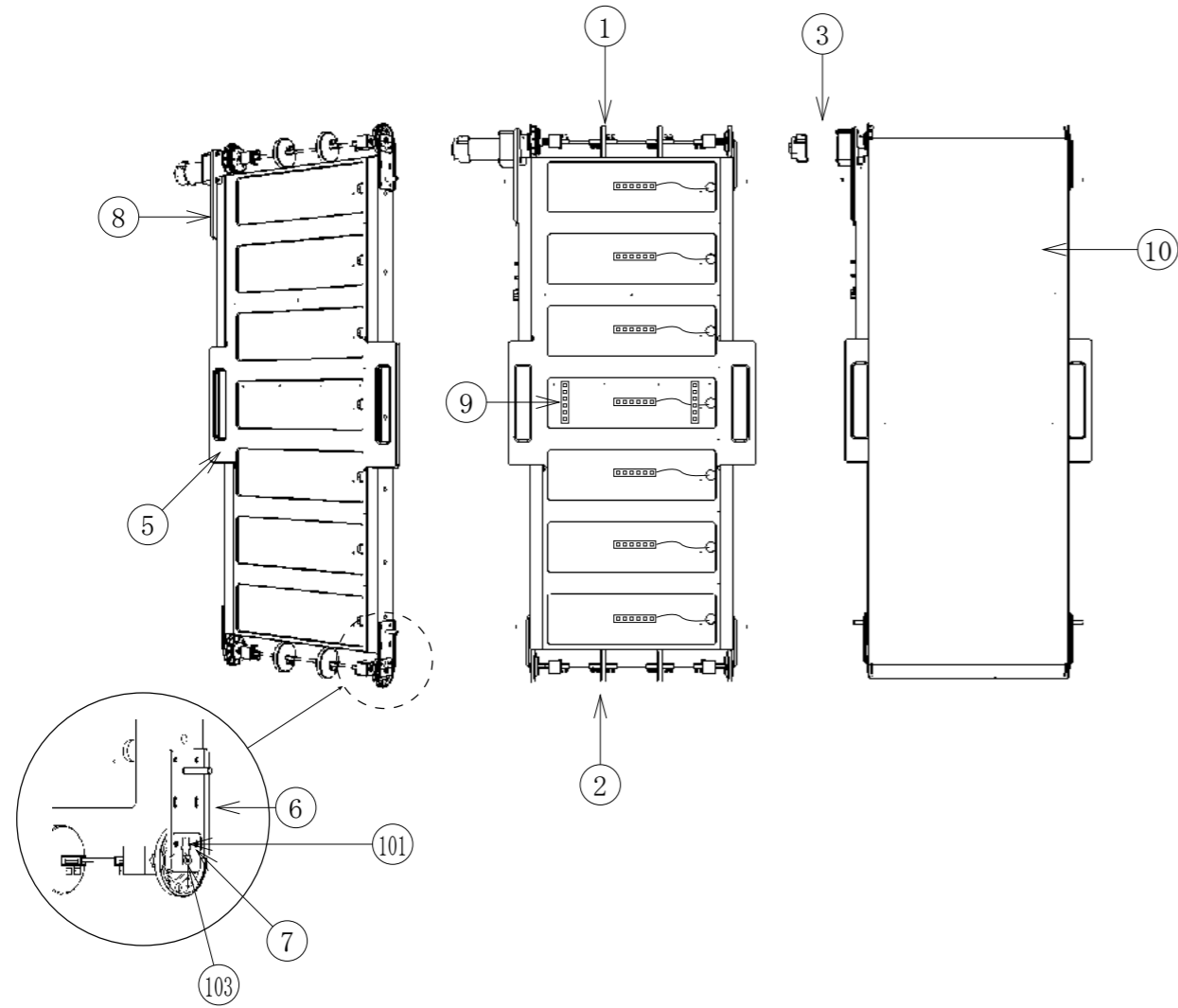

| ITEM NO | PART NUMBER | DESCRIPTION | QTY |
|---------|---------------|--------------------------------|-----|
| ***1 | SL-1210UK | ASSY UPPER SPOOL | 1 |
| ***2 | SL-1220UK | ASSY LOWER SPOOL | 1 |
| ***3 | SL-1230XUK | ASSY STEPPER MOTOR | 1 |
| ***5 | SL-1202XUK | BOARD FEATURE | 1 |
| ***6 | SL-1203XUK | BRKT SPOOL MOUNT | 3 |
| ***7 | SL-1204UK | PLATE SPOOL STOP | 3 |
| ***8 | SL-1207XUK | PLATE PANEL MOUNT | 1 |
| ***9 | SL-6001UK | ASSY LED BAND BACKLIGHT | 9 |
| ***10 | SL-1201-02UK | BAND 1.00 FEATURE | 1 |
| ***101 | 125-0003UK | TENSION SPRING GAMESMAN G4-693 | 2 |
| ***102 | 280-A01264-WX | ROUTER TWIST D12 SO6.4 WOOD X | 8 |
| ***103 | 253-0006UK | NYLON BUSH GAMESMAN G4-674 | 3 |
| ***104 | OS1249 | P CLIP 6.5MM | 18 |
| ***201 | 000-P00410-W | M4X10 MSCR PAN W/FS PAS | 18 |
| ***202 | 000-P00406-W | M4X6 MSCR PAN W/FS PAS | 6 |
| ***203 | 050-F00600 | M6 NUT FLG SER PAS | 3 |
| ***204 | 012-P03506-F | N6X1/4" S/TAP FLG PAS | 18 |
| ***301 | SL-60005UK | WH OPTO | 1 |
| ***302 | SL-60006UK | WH ROLLING ROAD LED | 1 |
| ***303 | SL-60007UK | WH LED LINK | 8 |
| ***304 | DB-60030UK | WH LED WHT | 1 |

⑩ ASSY UPPER SPOOL (SL-1210UK) (D-1/1)

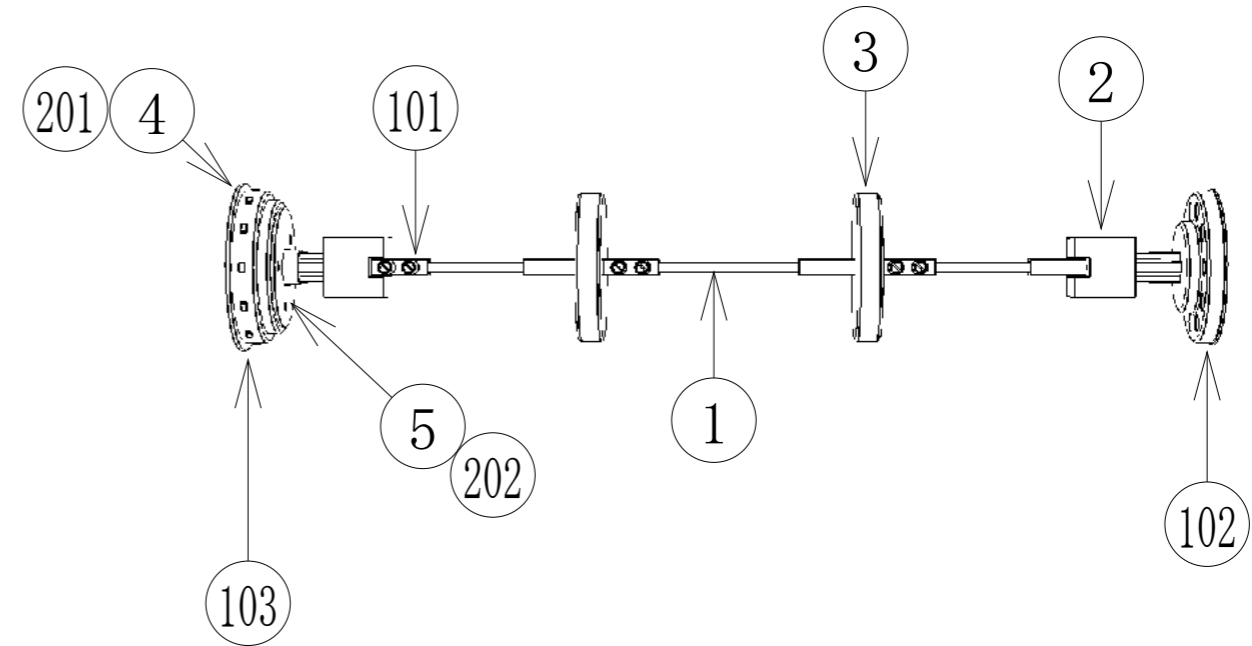

| ITEM NO | PART NUMBER | DESCRIPTION | QTY |
|---------|--------------|--|-----|
| ***1 | SL-1211UK | ROD UPPER SPOOL | 1 |
| ***2 | SL-1205XUK | BLOCK SPOOL | 2 |
| ***3 | SL-1206UK | DISC SPACER | 2 |
| ***4 | SL-1212UK | DISC BAND OUTER RETAINING | 1 |
| ***5 | SL-1213UK | DISC BAND INNER RETAINING | 1 |
| ***101 | EP1433 | STRIP TERMINAL 1277 12WAY 16A 117-8397 | 0.5 |
| ***102 | 253-0004UK | BAND SPOOL GAMESMAN G3-477 | 1 |
| ***103 | 253-0005UK | BAND DRIVE SPOOL GAMESMAN G3-478 | 1 |
| ***104 | | | |
| ***201 | 000-P00425-W | M4X25 MSCR PAN W/FS PAS | 3 |
| ***202 | 050-U00400 | M4 NUT NYLOK PAS | 3 |

⑪ ASSY LOWER SPOOL (SL-1220UK)

(D-1/1)

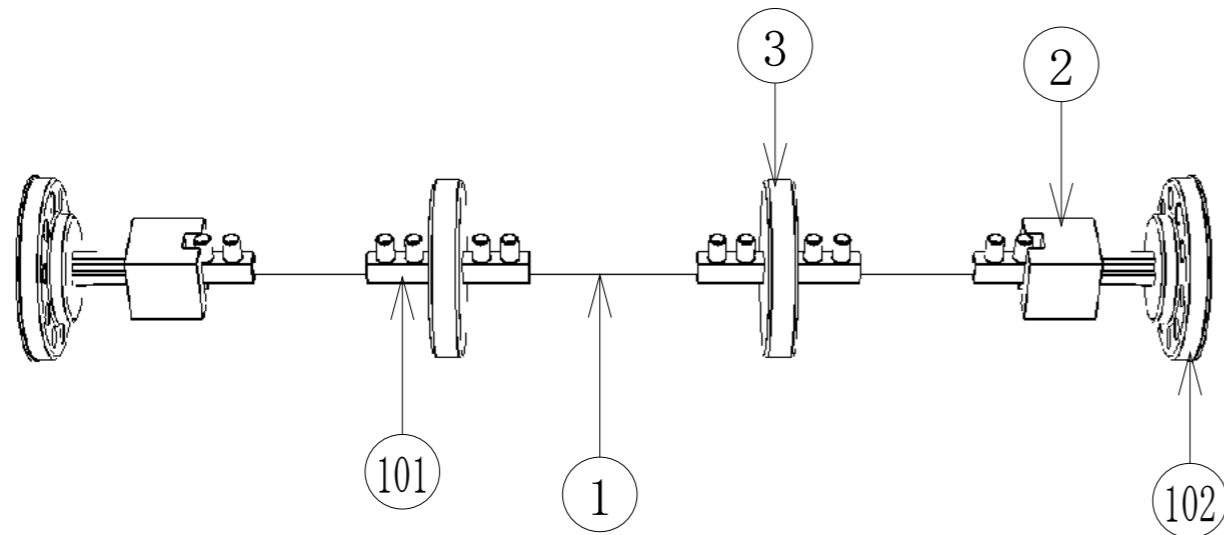

| ITEM NO | PART NUMBER | DESCRIPTION | QTY |
|---------|-------------|--|-----|
| ***1 | SL-1221UK | ROD LOWER SPOOL | 1 |
| ***2 | SL-1205XUK | BLOCK SPOOL | 2 |
| ***3 | SL-1206UK | DISC SPACER | 2 |
| ***101 | EP1433 | STRIP TERMINAL 1277 12WAY 16A 117-8397 | 0.5 |
| ***102 | 253-0004UK | BAND SPOOL GAMESMAN G3-477 | 2 |

⑫ ASSY STEPPER MOTOR (SL-2130XUK)

(D-1/1)

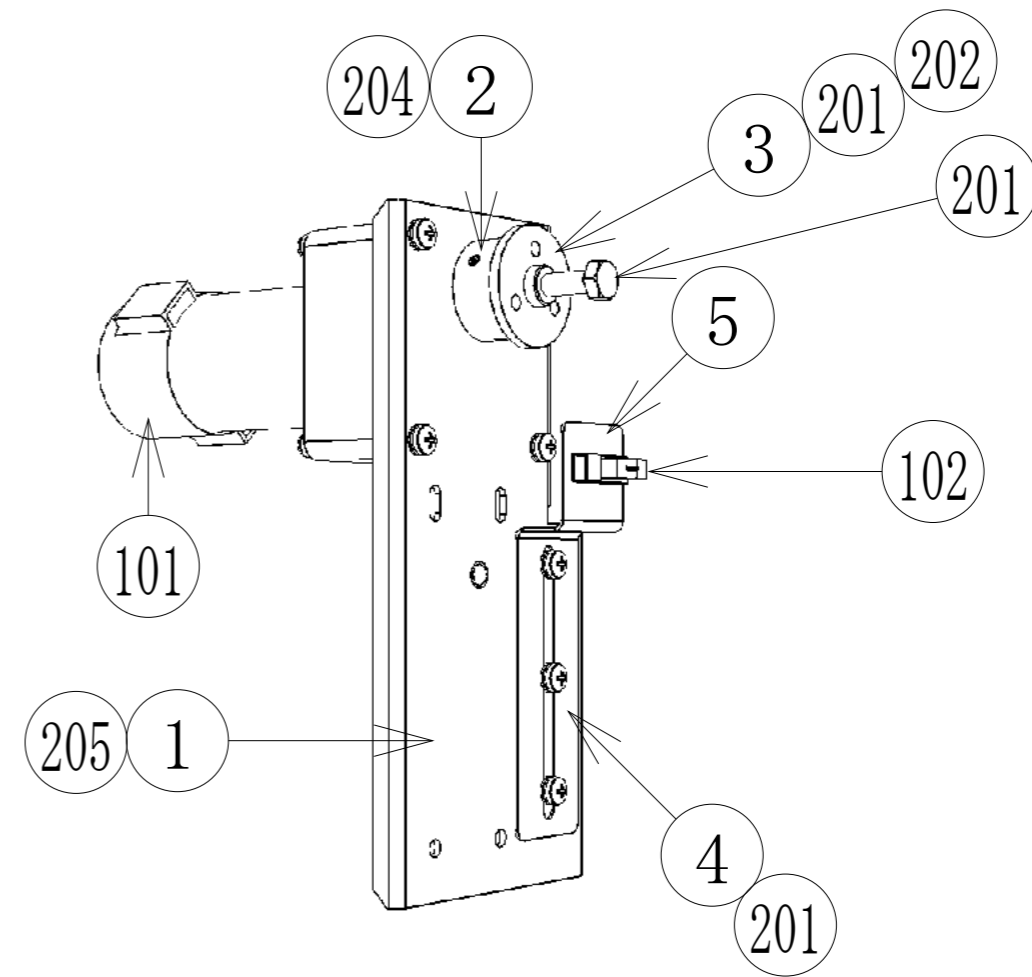

| ITEM NO | PART NUMBER | DESCRIPTION | QTY |
|---------|---------------|-------------------------------|-----|
| ***1 | SL-1231XUK | BRKT MOTOR | 1 |
| ***2 | DB-1452UK | COUPLER MOTOR SHAFT | 1 |
| ***3 | SL-1232XUK | COUPLER MOTOR PLATE | 1 |
| ***4 | SL-1233XUK | BRKT OPTO SENSOR | 1 |
| ***5 | SL-1234UK | BRKT OPTO GUIDE | 1 |
| ***101 | 350-012-312UK | MOTOR DC 12V WGB 5EN X0229840 | 1 |
| ***102 | EP1434 | OPTIC SENSOR GAMESMAN A151 | 1 |
| ***201 | 000-P00410-W | M4X10 MSCR PAN W/FS PAS | 10 |
| ***202 | 030-000620 | M6X20 BLT PAS | 1 |
| ***203 | | | |
| ***204 | FAS-200013 | M4X16 SKT CAP CRM | 3 |
| ***205 | 050-F00600 | M6 NUT FLG SER PAS | 1 |

⑬ ASSY LADDER PANEL (SL-1300UK)

(D-1/1)

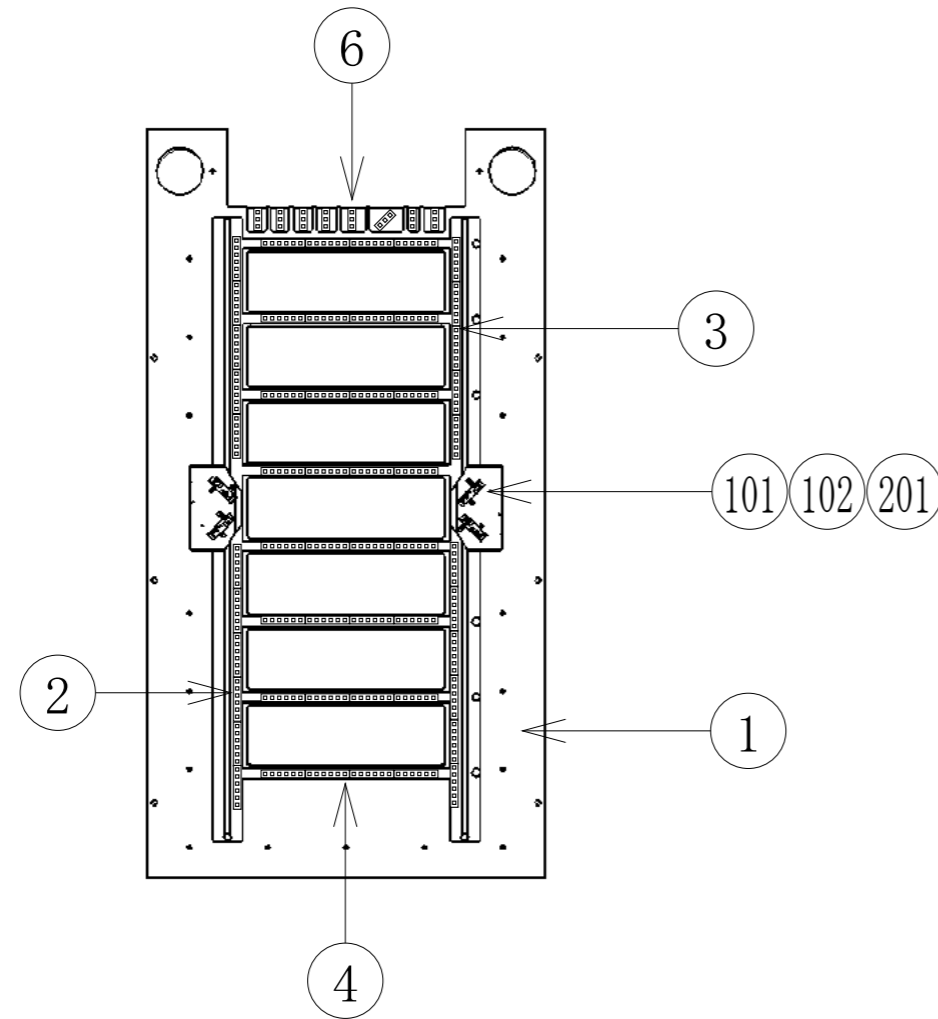

| ITEM NO | PART NUMBER | DESCRIPTION | QTY |
|---------|---------------|-------------------------------|-----|
| ***1 | SL-1301XUK | BOARD LADDER | 1 |
| ***2 | SL-6003UK | ASSY LED UPRIGHT LOWER | 2 |
| ***3 | SL-6002UK | ASSY LED UPRIGHT TOP | 2 |
| ***4 | SL-6004UK | ASSY LED LADDER RUNGS | 8 |
| ***6 | SL-6010UK | ASSY LED SUPER WIN | 1 |
| ***101 | 838-0025UK | BOARD SERIAL RGB | 4 |
| ***102 | OS1011 | PCB FEET RICHCO LCBS L-5-01 | 8 |
| ***103 | 280-A01264-WX | ROUTER TWIST D12 SO6.4 WOOD X | 21 |
| ***104 | OS1247 | ALUMINIUM STICKY CLIP | 4 |
| ***201 | 012-P00308 | N4X5/16" S/TAP PAN PAS | 8 |
| ***303 | DB-60033UK | WH SERIAL LED LINK | 2 |
| ***304 | DB-60041UK | WH RGB TERMINATOR | 1 |
| ***305 | SL-60016UK | WH CABINET TO WIN LINE RGB | 1 |
| ***306 | SL-60013UK | WH WIN LINE SERIAL LINK | 1 |

⑭ ASSY AC SWITCH (DB-1700UK)

(D-1/1)

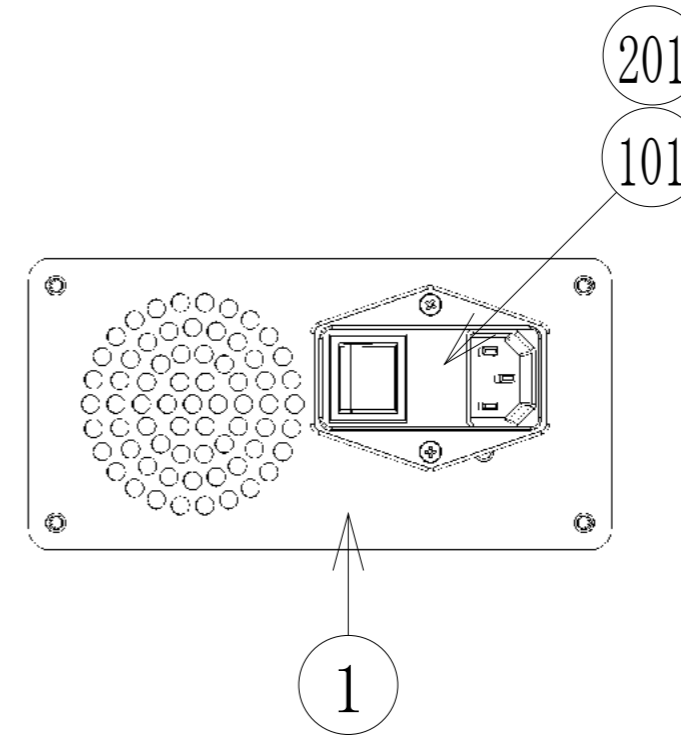

| ITEM NO | PART NUMBER | DESCRIPTION | QTY |
|---------|-------------|-----------------------------|-----|
| ***1 | DB-1701UK | MAINS IN PLATE | 1 |
| ***101 | EP1381 | FILTER IEC & SW 6A ROXBURGH | 1 |
| ***201 | 000-F00310 | M3X10 MSCR CSK PAS | 2 |
| ***301 | DB-60044UK | WH AC IN | 1 |

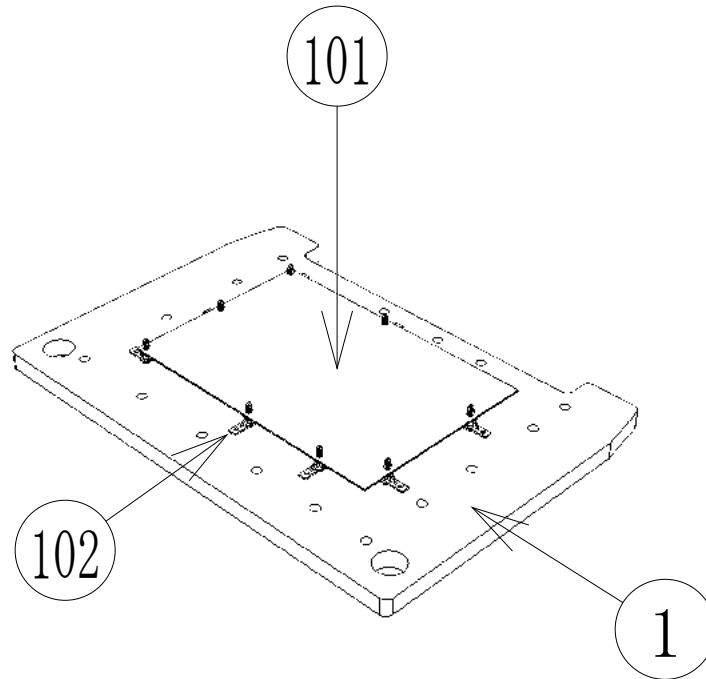

| ITEM NO | PART NUMBER | DESCRIPTION | QTY |
|---------|---------------|-------------------------------|-----|
| ****1 | DB-4101UK | WOODEN BASE MAIN BD | 1 |
| ****101 | 838-0023UK | PCBA - RED ONE | 1 |
| ****102 | 280-L00640-WX | STANDOFF 6MM 4 HOLE WOOD XL | 8 |
| ****103 | 280-A01264-WX | ROUTER TWIST D12 SO6.4 WOOD X | 6 |
| ****104 | 280-A02064-WX | ROUTER TWIST D20 SO6.4 WOOD X | 9 |
| ****302 | DB-60009UK | WH DC RED ONE | 1 |
| ****305 | DB-60012UK | WH DIRECT OUTS | 1 |
| ****309 | DB-60016UK | WH ST MOTOR | 1 |
| ****311 | DB-60018UK | WH CAN A | 1 |
| ****314 | DB-60041UK | WH TERMINATOR | 2 |
| ****315 | DB-60042UK | WH SERIAL CAT 5 | 1 |

19 WIRE COLOUR CODE TABLE

WARNING

The DC power wire color for this product is different from previous SEGA titles. Working from the previous wire colors will create a high risk of fire.

The color codes for the wires used in the diagrams in the following chapter are as follows.

| | |
|---|-------------|
| A | PINK |
| B | SKY BLUE |
| C | BROWN |
| D | PURPLE |
| E | LIGHT GREEN |

Wires other than those of any of the above 5 single colors will be displayed by 2 alphanumeric characters.

| | |
|---|--------|
| 1 | RED |
| 2 | BLUE |
| 3 | YELLOW |
| 4 | GREEN |
| 5 | WHITE |
| 7 | ORANGE |
| 8 | BLACK |
| 9 | GRAY |

If the right-hand side numeral of the code is 0, then the wire will be of a single color shown by the left-hand side numeral (see the above).

Note 1: If the right-hand side numeral is not 0, that particular wire has a spiral color code. The left-hand side character shows the base color and the right-hand side one, the spiral color.

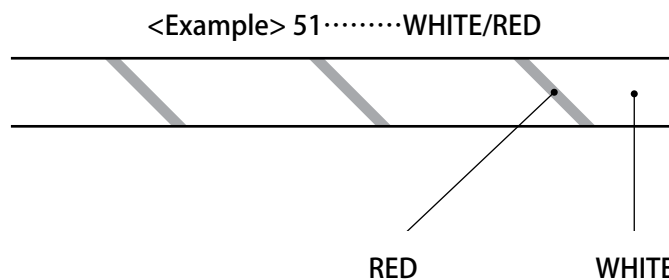

Note 2: The character following the wire color code indicates the size of the wire.

| | |
|--------|-------|
| U: | AWG16 |
| K: | AWG18 |
| L: | AWG20 |
| None : | AWG22 |

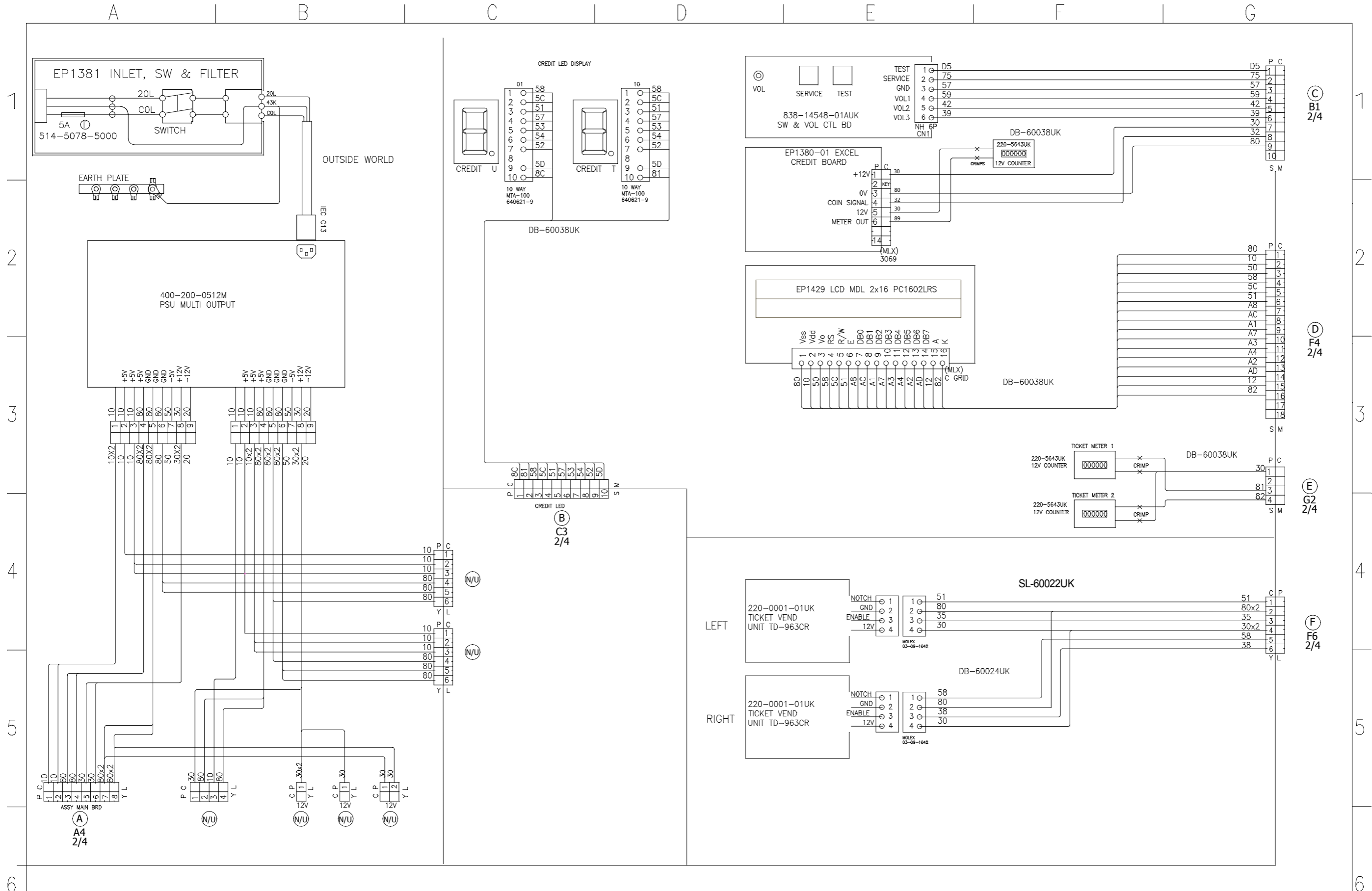

| | | | | | | | | |
|----------|---------------|----------------|--|-------------|-------|----------------------------|--|---------------------|
| 8 BLACK | | 4.3 EARTH WIRE | | PAGE 1 OF 4 | DRAWN | SEGA AMUSEMENTS EUROPE LTD | THIS DRAWING WILL IN NO WAY BE COPIED, TO BE RETURNED ON DEMAND. | ORIGINAL SIZE A2 |
| 7 ORANGE | E LIGHT GREEN | ? AWG18 UL1672 | | | | | | |
| 6 WHITE | D PURPLE | ? AWG20 UL1672 | | | | | | |
| 5 GREEN | C BROWN | U AWG16 UL1015 | | | | | | |
| 4 YELLOW | B SKY BLUE | K AWG18 UL1015 | | | | | | |
| 3 BLUE | A PINK | L AWG20 UL1007 | | | | | | |
| 2 BLUE | A PINK | L AWG20 UL1007 | | | | | | |
| 1 RED | 9 GRAY | T AWG24 UL1007 | | | | | | |

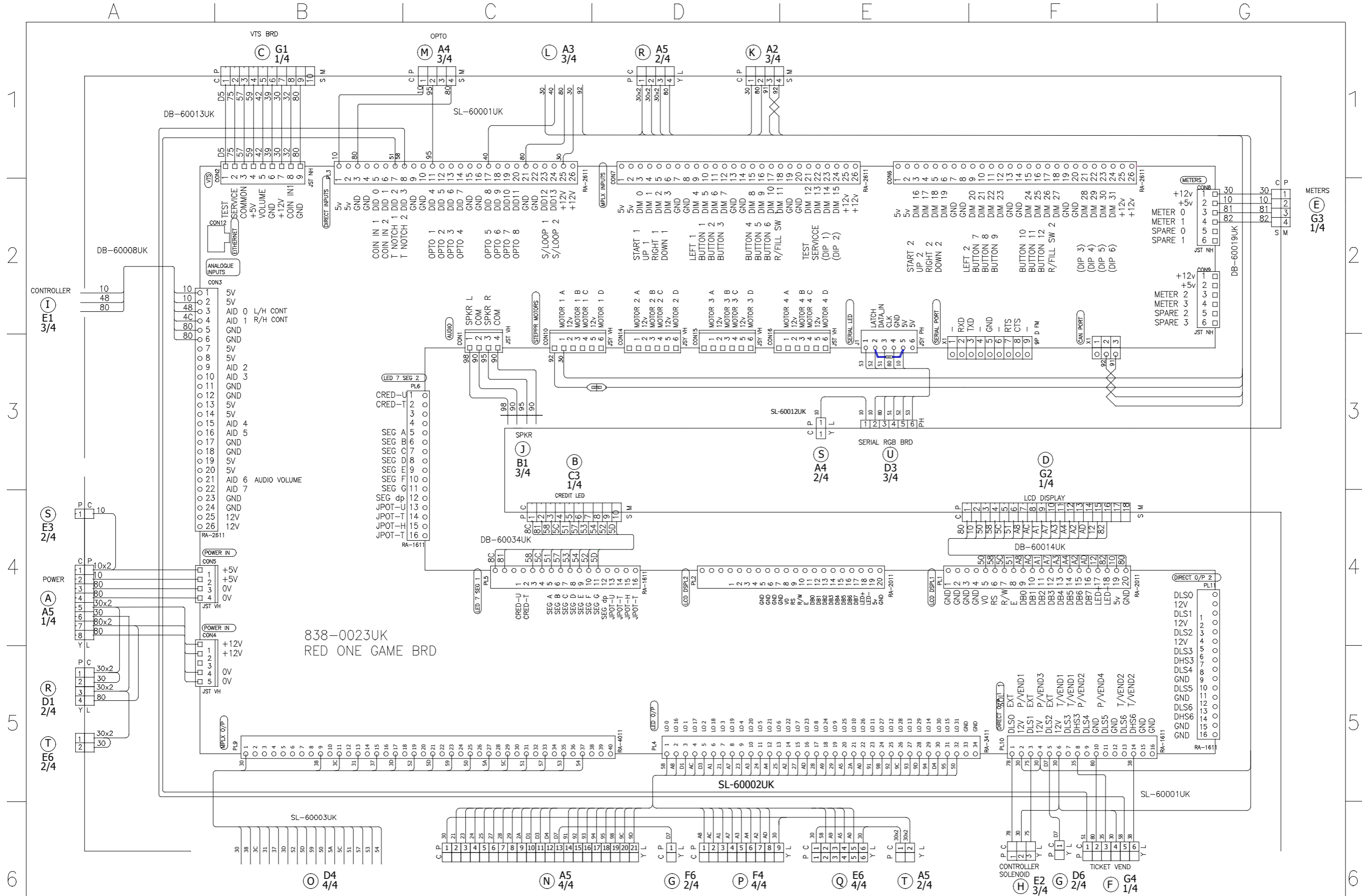

838-0023UK
RED ONE GAME BRD

| | | | |
|---|--------|-----|--------------|
| 8 | BLACK | 4-3 | EARTH WIRE |
| 7 | ORANGE | ? | AWG18 UL1672 |
| 6 | WHITE | ? | AWG20 UL1672 |
| 5 | GREEN | U | AWG16 UL1015 |
| 4 | YELLOW | B | SKY BLUE |
| 3 | BLUE | A | PINK |
| 2 | RED | 9 | GRAY |

PAGE 2 OF 4
PART NUMBER

DRAWN
SEGA AMUSEMENTS EUROPE LTD

DESCRIPTION
SEGA SNAKES & LADDERS

ORIGINAL SIZE
A2

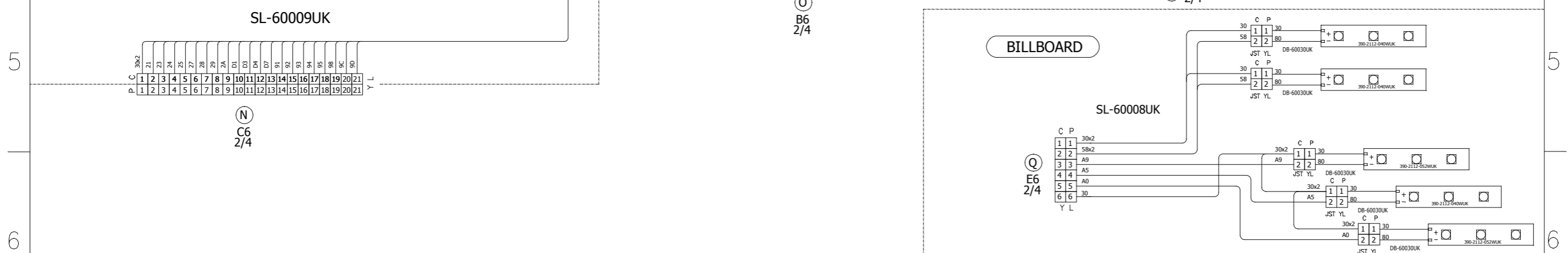
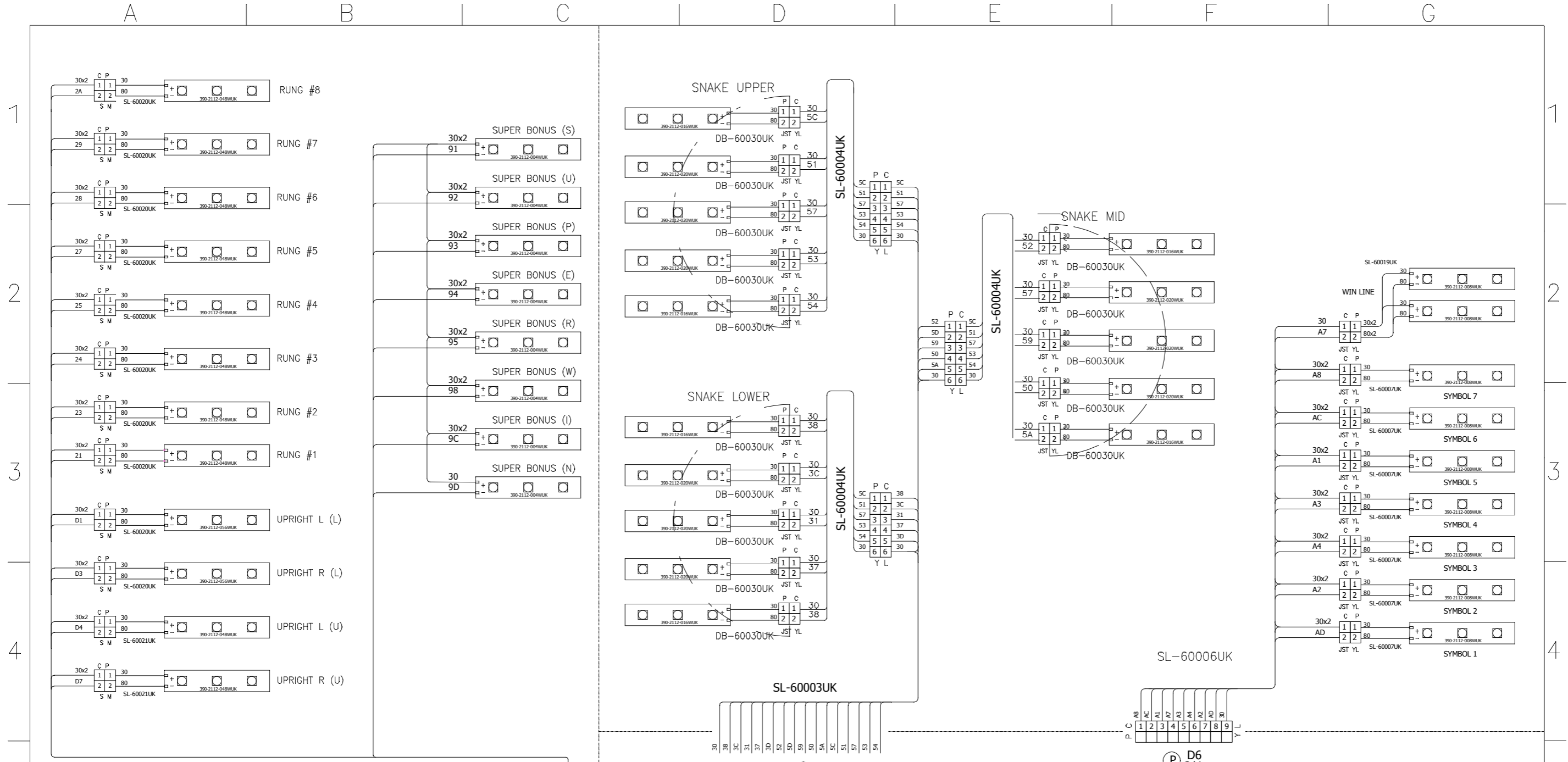

| | | | | | | | | |
|---|--------|---|-------------|-----|---------------|--|--|--|
| 8 | BLACK | E | LIGHT GREEN | 4-3 | EARTH WIRE | | | |
| 7 | ORANGE | D | PURPLE | ? | AWG18 U/L1672 | | | |
| 5 | WHITE | C | BROWN | U | AWG20 U/L1672 | | | |
| 4 | GREEN | B | SKY BLUE | K | AWG18 U/L1015 | | | |
| 3 | YELLOW | A | PINK | L | AWG20 U/L1007 | | | |
| 2 | BLUE | 9 | GRAY | T | AWG22 U/L1007 | | | |
| 1 | RED | | | | AWG24 U/L1007 | | | |