

namco[®]

TIME CRISIS 4 SD

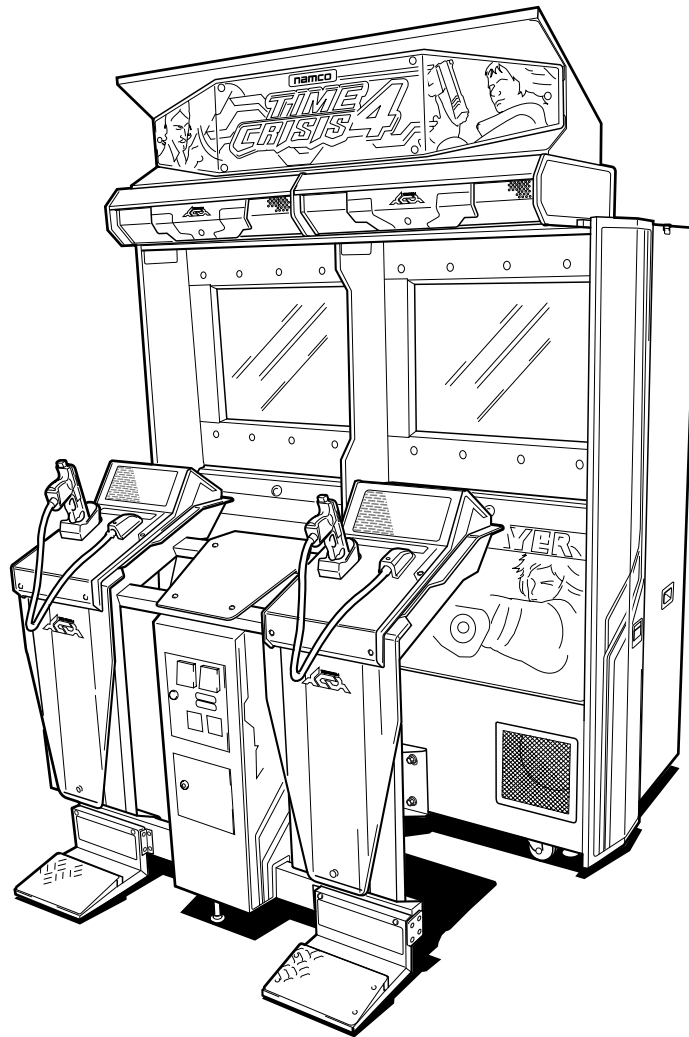

OPERATORS MANUAL

IT IS THE RESPONSIBILITY OF THE OPERATOR TO MAINTAIN CUSTOMER SAFETY
AT ALL TIMES, AND IT IS IMPERATIVE THAT THE DETAILS SET OUT IN THIS MANUAL
ARE FOLLOWED PRECISELY

INTRODUCTION

Thank you for purchasing the [TIME CRISIS 4 SD] game machine (hereafter referred to as the [machine]).

This operation manual describes:

- How to install, operate, relocate, transport, maintain and discard the machine safely and properly
- How to operate the machine correctly and make full use of its features
- How to ensure safety of players and bystanders
- Inquiries concerning the machine and repairs
- For further information about the machine and repairs, please contact your distributor.

MAGICGATE is a copyrighted anti-copying technology created by Sony Corp. This **MAGICGATE** mark does not necessarily imply compatibility with other products bearing the “MAGICGATE” trademark.

MAGICGATE is a trademark of Sony Corporation.

MAGICGATE est une technique de protection de copyright créée par Sony Corporation.

MAGICGATE ne veut pas nécessairement dire qu’il y a une compatibilité avec d’autres produits portant la marque commerciale “MAGICGATE”.

MAGICGATE est une marque commerciale de Sony Corporation.

Contents

OPERATORS MANUAL	1
INTRODUCTION	3
GENERAL SAFETY CONSIDERATIONS	6
ALLGEMEINE SICHERHEITSHINWEISE	8
GENERELLE SIKKERHEDSOVERVEJELSER	10
CONSIDERACIONES GENERALES DE SEGURIDAD.	12
CONSIGNES GENERALES DE SECURITE	14
ΕΞΕΤΑΣΗ ΓΕΝΙΚΗΣ ΑΣΦΑΛΕΙΑΣ	16
CONSIDERAZIONI GENERALI SULLA SICUREZZA	18
VANLIGE SIKKERHETSTILTAK	20
ALGEMENE VEILIGHEIDSOVERWEGINGEN	22
AVISOS DE PERIGO	24
ALLMÄNNA SÄKERHETSBEAKTANDEN	26
YLEISET TURVALLISUUNÄKÖKODAT	28
1. SPECIFICATIONS	30
2. MAIN COMPONENTS	31
4. INSTALLATION	32
3. MOVING THE MACHINE	33
4-1 Required Dimension for Access (Doors and Passageways)	36
4-2 Separating the Speaker Box	37
4-3 Fitting the Joint Box	38
4-4 Fitting the Header Assembly	40
4-5 Fitting the Joint Assy	42
4-6 Fitting the Control Assy	43
4-7 Adjusting the Level Adjusters	44
4-8 Fitting the Pedal Assy	45
5. OPERATION	46
5-1 Pre-Service Check	46
5-1-1 Safety Check (before power on)	46
5-1-2 Operation Check (after power On)	47
5-2 How to Play	48
6. ADJUSTMENTS	50
6-1 Adjustment Switches	51
6-2 Test Mode	52
6-2-1 Coin Options	54
6-2-2 Game Options	55
6-2-3 I/O Test	56
6-2-3-1 I/O PCB Check	57
6-2-3-2 Gun Initialize	58
6-2-3-3 Switch Test	61
6-2-3-4 Solenoid Test	62
6-2-3-5 LED Test	63
6-2-4 Monitor Test	64
6-2-5 Sound Test	65
6-2-6 Bookkeeping	66
6-2-7 Others	67

7. MAINTENANCE	68
7-1 Cleaning	70
7-1-1 Cleaning the Gun Assy	70
7-1-2 Cleaning the Front Acrylic Cover	70
7-2 Regular Maintenance	71
7-2-1 Greasing the Pedal Plunger	71
7-2-2 Checking the Plunger for Wear	73
7-3 Removing the Monitor Mask	74
7-4 Replacing the LED Board	75
7-5 Replacing the Game PCB Assy	76
7-6 Replacing the Amp PC Board	77
7-7 Replacing the SIDELED PC Board (Header Assy)	78
7-8 Replacing the Fluorescent Tube / Starter	80
7-9 Removing the Control Panel	81
7-10 Replacing the SIDELED PC Board	82
7-10-1 (Control Panel)	82
7-10-2 (Gun Assy)	83
7-11 Replacing the NA-JV Board Assy	84
7-12 Replacing the CPU Board	85
7-13 Replacing the Gun Assy	87
7-14 Replacing the Gun Slides (L & R)	88
7-15 Separating The Gun Body	89
7-16 Replacing the Gun Light Receiving Unit	90
7-17 Replacing the Gun Solenoid	91
7-18 Replacing the Trigger Microswitch	92
7-19 Replacing the Gun Harness	93
7-20 Replacing the Pedal Micro Switch	94
7-21 Replacing the Pedal Plunger	95
7-22 Removing the Monitor	96
8. TROUBLESHOOTING	98
8-1 Monitor Cabinet Assy	98
8-2 Header Assy	98
8-3 Pedal Assy	98
8-4 Control Assy	99
8-5 Gun Assy	99
9. PARTS	100
9-1 Monitor Cabinet	100
9-2 Speaker Box Assy	102
9-3 Header Assy	103
9-4 Game PCB Assy	104
9-5 Control Assy	106
9-6 Service Bracket Assy	107
9-7 Coin Tower Assy	108
9-8 Pedal Assy	109
9-9 Gun Tower Assy (L)	110
9-10 Gun Tower Assy (R)	112
9-11 Gun Assy	114
9-12 Joint Box Assy	116
10. DISPOSAL	117
11. SCHEMATICS	118



No part of this publication may be reproduced by any mechanical, photographic or electronic process, or in the form of phonographic recording, nor may it be stored in a retrieval system, transmitted or otherwise copied for private use, without permission from **NAMCO EUROPE LIMITED**.

While the information contained in this manual is given in good faith and was accurate at the time of printing, NAMCO EUROPE LIMITED reserve the right to make changes and alterations without notice.

This equipment has been manufactured in accordance with European Directives, and has been tested and complies with the directives 89/336/EEC and 72/23/EEC by the application of EN55014-1, EN55014-2 and EN60334-2-82 standards and as such bears the CE marking. Any changes or modifications to this equipment must be in accordance with the European Directives. Any unauthorised changes to this equipment may contravene such directives.

Under some conditions of extreme external interference, e.g. radio transmissions, electrostatic discharge or mains born transients, some degradation of performance may occur. However the equipment will recover normal performance once the source of interference has ceased or been removed.

Following abnormally high surges on the mains supply, the video monitor may need to be manually reset by turning the equipment OFF and back ON.

If the game processor resets due to an interruption of the mains voltage, any credits established will be lost.

This equipment is not a machine as defined by the machinery directive 89/392/EEC.

SAFETY WARNING

In order to use this equipment safely, be sure to read this Operators Manual carefully before installation, adjustment or use of this equipment.

Whenever the owner of this equipment entrusts dis-assembly, installation, adjustment or routine maintenance to another person, the owner should ensure that that person reads the appropriate precautions and relevant sections of this manual before starting work.

In order that no accidents occur when the equipment is in operation, strictly follow the notes on safety as described below.

This manual along with the Installation Manual (where applicable) form an integral part of the equipment and must be available to the operating or service personnel at all times.

This equipment is for indoor use only and should only be used for the purpose intended.

Namco Europe Ltd. bears no responsibility for accidents, injury or damage resulting from unauthorized changes to, or improper use of this equipment.

SAFETY NOTES

The following safety notes are used throughout this manual. Familiarize yourself with each of these notes and its meaning before installing, servicing or making adjustments to this equipment.

WARNING ⚠ Warning denotes a hazard that could result in injury or death. Do not proceed beyond a warning note until the indicated conditions are fully understood and met.

CAUTION ⓘ Caution denotes a hazard that could result in damage to the equipment. Do not proceed beyond a caution note until the indicated conditions are fully understood and met.

GENERAL SAFETY CONSIDERATIONS

- ⚠ **Only operate this equipment after checking that it has been installed correctly and in accordance with this manual.**
- ⚠ **The warning notices must always be kept in good condition and replaced if worn, so that customers can read them clearly.**
- ⚠ **Installation, service, adjustment or routine maintenance should be carried out by suitably qualified persons only.**
- ⚠ **For continued protection against fire hazard, replace fuses with the same type and rating. The use of other fuses or material is prohibited.**
- ⚠ **The power supply inside the monitor will remain hot and have areas of high voltage even though the equipment has been tuned OFF, and there is the possibility of burns or electric shock. Be careful not to touch these areas.**
- ⚠ **To prevent possible electric shock due to failure, this equipment **MUST** be fitted with a securely connected EARTHED plug.**
- ⚠ **If at any time the mains lead becomes damaged, it must be replaced immediately.**
- ⚠ **Do not turn the power switch ON until the equipment has been installed correctly.**
- ⓘ Before connecting the machine to the mains supply, ensure that the equipment is set for the correct voltage and that the correct fuses are fitted.

NOTES ON INSTALLATION

- ⚠ **NEVER** turn the power to the machine ON until installation has been completed.
- ⚠ In order to prevent possible electric shocks, be sure that the equipment is connected to the mains with a securely connected earthed plug.
- ⚠ So that customers are not injured by the movement of the equipment, ensure that there is at least 500mm separation between other equipment or walls.
- ⓘ In order to avoid damage to the equipment due to mis-operation, ensure that the voltage of the mains supply is 230volts AC.

Note: If the location of this equipment has a polished floor, it is recommended that rubber pads are fitted under the level adjusters to prevent the equipment sliding on the floor when in use.

Note: In order to gain access to the Power Supply and CPU assemblies, ensure that the rear of the equipment is separated from a wall or other equipment by at least 500mm

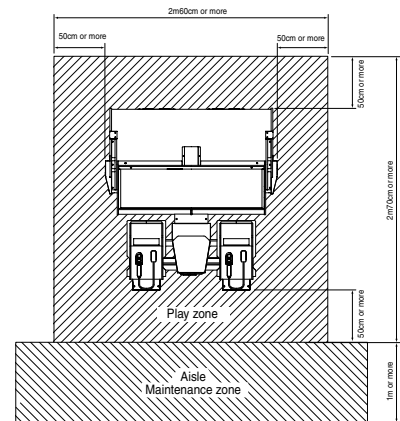

MOVING THE EQUIPMENT

- ⚠ This equipment is fitted with castors to make it easier to move. Take care when moving the equipment on an inclined surface.
- ⚠ The Header Assembly has a forward centre of gravity, so it is important that at least **two people** are used to fit or remove the Header Assembly.
- ⚠ The fitting position of the Header Assembly is high, and it is important that a means of reaching the height safely, without stretching, is available. (e.g. Steps, Step Stool etc.)
- ⚠ The overall height of the equipment, with the Header Assembly fitted, is 2220mm. Take care of any overhead obstructions. (e.g. Light Fittings, Electric Cables etc.)

REMOVING AND REPLACING PARTS

- ⚠ Adjustments or maintenance on this equipment should be carried out by suitably qualified personnel only.
- ⚠ Do not make any alteration to this equipment without prior approval. Doing so could cause unforeseeable danger.
- ⚠ Only parts specified by Namco Europe Ltd. should be used when replacing parts. (Including screws)
- ⚠ Ensure that the power to the equipment is turned OFF before commencing any maintenance work. (Trouble shooting, repairs etc.)
- ⚠ If performing work not described in this manual, contact your distributor for instructions, as no responsibility will be accepted for damage or injury.
- ⚠ Parts of the Power Supply and Monitor remain hot and carry high voltage even after switching OFF and could cause burns or electric shock. Take care not to touch these parts accidentally.
- ⚠ Make sure that the equipment is switched OFF before connecting or disconnecting any plugs or connectors.
- ⚠ When removing the mains connector from the equipment, or the mains plug from the wall outlet, always grasp the plug and not the cable.



Dieses Dokument darf in keiner Weise vervielfältigt werden. Jegliche Tonaufnahmen sowie die Speicherung auf Datenträger (Suchsysteme), die Weitergabe oder sonstiges Kopieren für den gewerblichen und privaten Gebrauch sind untersagt und bedürfen der vorherigen Genehmigung durch NAMCO EUROPE LIMITED.

Die Informationen in diesem Handbuch entsprechen den Tatsachen bei Drucklegung. NAMCO EUROPE LIMITED behält sich jedoch das Recht zu Änderungen ohne vorherige Bekanntgabe vor.

Dieses Gerät trägt das CE-Zeichen und wurde gemäß den EU-Richtlinien produziert. Es erfüllt die Richtlinien 89/336/EEC und 72/23/EEC und Standards EN 55014-1, EN55014-2 und EN60334-2-82 (s. Deckblatt des Handbuches). Alle Veränderungen an diesem Gerät müssen in Übereinstimmung mit den EU-Richtlinien erfolgen. Nicht genehmigte Veränderungen an diesem Gerät verstoßen gegen diese Richtlinien.

Extreme äußere Störungen, wie z.B. durch Radiobetrieb, elektrostatische Entladung oder zeitweilige Netzschwankungen können zu einer Leistungsminderung führen. Sobald diese Faktoren jedoch ausgeschaltet oder beseitigt wurden, erreicht das Gerät seine normale Leistung.

Achtung! Falls der Spielprozessor auf Grund von Netzunterbrechungen oder Abnahme der Netzspannung aussetzt, kann es zum Verlust von Spielkrediten kommen.

Dieses Gerät fällt nicht unter die Maschinen-Richtlinie 89/392/EEC

SICHERHEITSHINWEISE

Um einen ordnungsgemäßen Betrieb dieses Gerätes zu gewährleisten, muß vor Aufstellung, Inbetriebnahme und Gebrauch das Handbuch sorgfältig gelesen werden.

Sobald der Besitzer dieses Gerätes die Demontage, Aufstellung, Inbetriebnahme oder den Service einer anderen Person überträgt, muß er sicherstellen, daß diese Person vor Arbeitsbeginn die nötigen Sicherheitshinweise und die dazugehörigen Kapitel des Handbuches liest und versteht.

Um jegliche Unfälle während des Betriebes zu vermeiden, müssen obige Hinweise strikt befolgt werden.

Dieses Handbuch sowie das spezielle Geräte-Handbuch (wenn vorhanden) gehören zum Gerät und müssen dem Betreiber und Wartungspersonal stets zugänglich sein

Dieses Gerät ist ausschließlich für den gewerblichen Gebrauch in geschlossenen Räumen bestimmt und darf nur dort betrieben werden.

NAMCO EUROPE Ltd. übernimmt keinerlei Haftung für Unfälle, Verletzungen oder Beschädigungen, die auf nicht genehmigte Veränderungen oder unsachgemäßen Betrieb des Gerätes zurückzuführen sind.

SICHERHEITSHINWEISE

Folgende Sicherheitsbegriffe werden im gesamten Handbuch benutzt. Machen Sie sich daher bitte vor Inbetriebnahme, Wartung und Durchführung von Einstellungen am Gerät mit diesen Warnhinweisen vertraut.

WARNUNG ⚠ **WARNUNG bezeichnet eine Gefahrenquelle für Leib und Leben. Erscheint dieser Warnhinweis, darf erst weitergearbeitet werden, wenn die entsprechenden Erklärungen vollständig verstanden und befolgt wurden.**

VORSICHT ⓘ **VORSICHT bezeichnet eine Gefahrenquelle für die Beschädigung des Gerätes. Erscheint dieser Warnhinweis, darf erst weitergearbeitet werden, wenn die entsprechenden Erklärungen vollständig verstanden und befolgt wurden.**

ALLGEMEINE SICHERHEITSHINWEISE

- ⚠ **Das Gerät darf nur betrieben werden, nachdem es vorschriftsmäßig und in Übereinstimmung mit dem Handbuch aufgestellt wurde.**
- ⚠ **Die Warnschilder müssen in gutem Zustand sein und ersetzt werden, wenn sie nicht mehr gut lesbar sind.**
- ⚠ **Bei Auftreten eines Fehlers oder Problems muß das Gerät sofort abgeschaltet werden und darf erst nach fachgerechter Behebung des Fehlers wieder in Betrieb genommen werden.**
- ⚠ **Aufstellung, Service, Einstellungen und Wartung dürfen nur von dafür qualifiziertem Fachpersonal durchgeführt werden.**
- ⚠ **Zur Vermeidung von Feuer, defekte Sicherungen nur durch vorgeschriebene Sicherungen ersetzen. Die Verwendung von andersartigen Sicherungen oder unterschiedlichem Material ist untersagt.**
- ⚠ **Das Netzteil im Monitor bleibt nach Ausschalten des Gerätes noch heiß und führt weiterhin Hochspannung. Daher besteht die Gefahr von Verbrennungen und Elektroschlägen. Diese Bereiche dürfen nicht berührt werden.**
- ⚠ **Zur Vermeidung von Elektroschlägen muß dieses Gerät mit einem ordnungsgemäß geerdeten Netzstecker versehen sein.**
- ⚠ **Bei Beschädigungen des Netzteiles muß dieses umgehend ersetzt werden.**
- ⚠ **Gerät erst nach abgeschlossener Aufstellung einschalten.**
- ⓘ **Vor Einstecken des Netzsteckers bitte sicherstellen, daß Netzspannung und Gerätespannung übereinstimmen, und die vorgeschriebenen Sicherungen verwendet wurden.**

HINWEISE ZUR AUFSTELLUNG

- ⚠ **NIEMALS** das Gerät einschalten bevor die Aufstellung völlig abgeschlossen ist.
- ⚠ Zur Vermeidung von Elektroschlägen muß das Gerät mit einem ordnungsgemäß geerdetem Netzstecker an die Stromversorgung angeschlossen werden.
- ⚠ Um zu vermeiden, daß Kunden durch die Gerätebewegungen verletzt werden, muß ein Sicherheitsabstand zu anderen Geräten und Wänden von mindestens 50cm eingehalten werden.
- ⓘ Zur Vermeidung von Beschädigungen durch Fehlbetrieb am Gerät sicherstellen, daß die Netzspannung 230 Volt beträgt.

Hinweis: Ist das Gerät für einen Aufstellplatz mit glattem Fußboden bestimmt, müssen die Standbeine mit Gummiplättchen unterlegt werden, damit das Gerät fest steht und nicht auf dem Boden hin- und herrutscht.

Hinweis: Zu Reparaturzwecken am Netzteil und den CPU-Komponenten muß die Rückseite des Gerätes mindestens 50cm von anderen Geräten und der Wand entfernt sein.

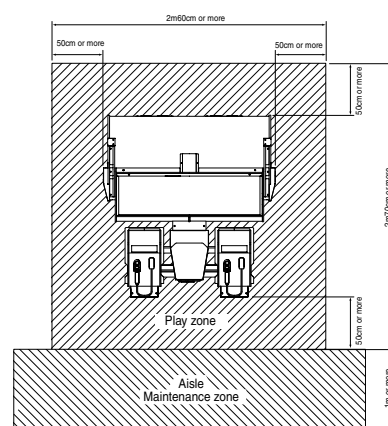

- ⚠ Zum leichteren Transport ist das Gerät mit Rollen ausgerüstet. Daher besondere Vorsicht auf abschüssigem Boden
- ⚠ Der Schwerpunkt des Aufsatzes liegt sehr weit vorn. Daher werden für den Ab- und Aufbau des Aufsatzes mindestens 2 Personen benötigt.
- ⚠ Der Aufsatz wird in großer Höhe montiert. Daher muß aus Sicherheitsgründen eine Steighilfe, wie z. B. eine Leiter, ein Tritt oder ähnliches, verwendet werden.
- ⚠ Die Gesamthöhe des Gerätes beträgt 2.20m. Daher Vorsicht bei tiefer hängenden Beleuchtungskörpern.

AUS- UND EINBAU VON KOMPONENTEN UND TEILEN

- ⚠ Aufstellung, Service, Einstellung und Wartung dürfen nur von dafür qualifiziertem Fachpersonal durchgeführt werden.
- ⚠ Es dürfen keinerlei Veränderungen ohne vorherige Genehmigung am Gerät vorgenommen werden. Zuwiderhandlungen stellen eine Gefahrenquelle dar.
- ⚠ Für die Reparatur dürfen nur Originalersatzteile (incl. Schrauben) von NAMCO EUROPE LTD. verwendet werden.
- ⚠ Vor Beginn aller Wartungsarbeiten (Fehlersuche, Reparaturen etc.) muß der Netzstecker gezogen werden.
- ⚠ Bei Arbeiten, die nicht in diesem Handbuch beschrieben werden, muß vorher der Händler zu Rate gezogen werden, da sonst keinerlei Haftung bei Beschädigungen und Verletzungen übernommen wird.
- ⚠ Teile des Netzteiles und Bildschirms bleiben nach Abschalten noch heiß und führen Hochspannung. Dies kann zu Verbrennungen oder einem Elektroschlag führen. Diese Teile dürfen nicht berührt werden.
- ⚠ Vor der Montage oder dem Entfernen von Steckverbindungen und Steckern muß das Gerät ausgeschaltet werden.
- ⚠ Bei Ziehen des Gerätesteckers oder des Netzsteckers aus der Wandsteckdose stets den Stecker greifen und nicht das Kabel.



Denne udgivelse må ikke reproducere af nogen som helst mekanisk, fotografisk eller elektrisk proces eller i form af indspilning, den må heller ikke lagres i et eftersøgningsystem transmitteres eller kopieres til nogen form for offentlig benyttelse uden tilladelse fra **Namco Europe Limited**.

Da informationerne i denne manual er givet med god tro og var korrekt på udskivningstidspunktet, forbeholder Namco Europe Limited sig retten til, at foretage ændringer og forandringer uden varsel.

Denne maskine er fremstillet i overensstemmelse med Det Europæiske fællesskabs direktiver og er blevet testet og fuldstændt med direktiverne 89/336/EEC og 72/23/EEC standarder (se manualens forside) og som sådan bærer CE mærket. Enhver form for ændring eller modifikation af denne maskine skal være i overensstemmelse med Det Europæiske fællesskabs direktiver.

I tilfælde af forbigående ekstreme eksterne forstyrrelser, så som radio udsendelser, elektronisk afgivelse eller forstyrrelser på ledningsnettet, kan nedbrydning forekomme. Maskinen vil dog køre normalt så snart forstyrrelsen ophører eller bliver fjernet.

Bemærk:- Hvis spilleprocessoren resetter p.g.a. en forstyrrelse eller reduktion af hovedstrømmen kan de etablerede kreditter gå tabt.

Dette spil er ikke en maskine defineret af maskin direktivet 89/392/EEC -

SIKKERHEDS ADVARSEL

For at betjene denne maskine sikkert, læs da denne brugemanual grundigt før installation, justering eller brug af maskinen.

Når som helst ejeren af denne maskine overlader demontering, installation, justeringer eller daglig vedligehold til en anden person, skal ejeren sikre sig at denne person læser de sikkerhedsregler og relevante punkter i denne manual før arbejdet begynder.

For at undgå ulykker når maskinen er i gang, følg nøje de sikkerhedsregler der er beskrevet herunder.

Denne manual sammen med installations manualen er en uløselig del af udstyret og skal altid være til rådighed for det arbejdende og servicerende personale.

Denne maskine er kun til indendørs brug og bør kun bruges til det beregnede formål.

Namco Ltd. bærer intet ansvar for ulykker eller skader som er et resultat af uautoriserede ændringer eller fejlagtig brug af denne maskine.

SIKKERHEDSREGLER

De følgende sikkerhedsregler er brugt helt igennem denne manual. Gør dig bekendt med hver enkelt af dem og meningen heraf før installation, servicering eller justering af denne maskine.

ADVARSEL ⚠ **Advarsel betegner en episode der kan resultere i skader eller død. Begiv dig ikke forbi et advarselsskilt før de indikerede betingelser er fuldstændig forstået.**

FORSIGTIG ⓘ Forsigtig betegner en episode der kan resultere i ødelæggelse af maskinen. Begiv dig ikke forbi et advarselsskilt før de indikerede betingelser er fuldstændig forstået.

GENERELLE SIKKERHEDSOVERVEJELSER

- ⚠ **Betjen kun maskinen efter at have tjekket, at den er korrekt installeret og er i overensstemmelse med manualen.**
- ⚠ **Advarselsskiltene skal altid være i god stand og erstattes hvis de er slidt, så kunden tydeligt kan læse dem.**
- ⚠ **Hvis der er en fejl eller et problem med maskinen skal betjening straks stoppes, og problemet afhjælpes før yderligere brug.**
- ⚠ **Installations service, justeringer eller daglig vedligehold bør kun udføres af en kvalificeret person.**
- ⚠ **For fortsat beskyttelse mod brandfare, sikres at hoved sikringerne kun erstattes med samme type kapacitet. Brug af anden kapacitet eller materiale er forbudt.**
- ⚠ **Strømforsyningen inde i monitoren vil forblive varin og have områder med høj spænding selvom maskinen har været slukket og der er fare for brandskader eller elektrisk stød. Pas på med at røre disse områder.**
- ⚠ **For at undgå elektrisk stød p.g.a. en fejl skal denne maskine være forbundet med et sikkert jordstik.**
- ⚠ **Hvis hoved ledningerne på noget tidspunkt bliver beskadiget skal de strakt erstattes.**
- ⚠ **Tænd ikke for strømmen før maskinen er korrekt installeret.**
- ⚠ **Før tilslutning af maskinen til hovedstrømmen sikres, at maskinen er indstillet til den rette spænding.**

PUNKTER OM INSTALLATION

- ⚠ **Tænd aldrig for strømmen til maskinen før installation er fuldført.**
- ⚠ For at undgå mulige elektriske stød sikres, at maskinen er forbundet til hovedstrømmen med sikkert monterede jordstik.
- ⚠ For at kunder ikke kommer til skade ved spillets bevægelser sikres, at der er mindst 50cm afstand til andre maskiner og vægge.
- ⓘ For at undgå skader på maskinen p.g.a. fejlbetjening sikres, at spændingen på hovedstrømmen er 230 volt AC.

BEMÆRK : Hvis denne maskine placeres på et poleret gulv, anbefales det at ligge gummimåtter under justeringsfødderne for at undgå at maskinen glider på gulvet.

BEMÆRK : For at få adgang til strømforsyningen og CPU justeringer sikres, at bagsiden af hoved kabinettet står adskilt fra andre maskiner eller væggen med mindst 50cm.

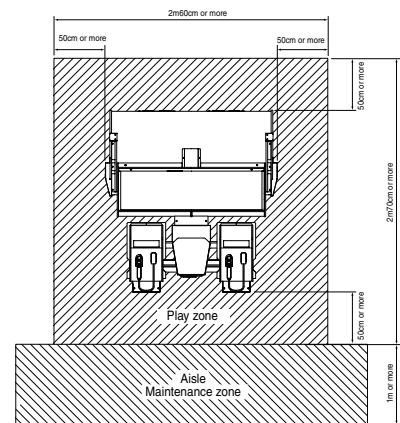

- ⚠ **Maskinen er smurt med olie for at gøre den lettere bevægelig. Pas på når maskinen flyttes på en skrå overflade.**
- ⚠ **Hoved sektionens forreste center er meget tung, det er derfor vigtigt, at mindst 2 personer benyttes til at montere el. flytte hoved sektionen.**
- ⚠ **Monterins højden af hoved sektionen er meget høj og det er vigtigt, at have hjælpemidler til at nå sikkert uden at skulle strække sig. (fek.s. trapper, trappestole el. lign.).**
- ⚠ **Den fulde højde af hoved sektionen er 2.20m. Pas på øvre forhindringer f.eks. lys inventar**

AT FJERNE OG UDSKIFTE SEKTIONER OG DELE.

- ⚠ **Justeringer eller vedligehold af denne maskine bør kun udføres af kvalificeret personale.**
- ⚠ **Skift ikke noget på maskinen uden godkendelse, det kan føre til uforudset fare.**
- ⚠ **Der bør kun bruges dele specificeret af Namco Europe Limited når der skiftes eller repareres dele (inklusiv skruer).**
- ⚠ **Sørg for, at strømmen til maskinen er slukket før der foretages nogen form for arbejde (fejlfinding, reparation etc.)**
- ⚠ **Hvis der foretages arbejde der ikke er beskrevet i denne manual, kontakt da din leverandør for at få kyndig vejledning, da intet ansvar vil blive accepteret ved skader.**
- ⚠ **Dele af strømforsyningen og monitoren forbliver varme eller bærer høj spænding selv efter maskinen er slukket, det kan føre til forbrændinger eller elektriske stød. Pas på ikke at røre disse dele ved et uheld.**
- ⚠ **Læg mærke til at maskinen er slukket før samlinger eller stik tages ud eller sættes i.**
- ⚠ **Når hovedsamlingen fjernes fra maskinen eller hovedstikket fjernes fra væggen, tag da altid ved stikket, ikke ledningen.**



No se permite la reproducción total ni parcial de esta publicación por ningún medio mecánico, fotográfico o electrónico, grabaciones fonográficas, ni su almacenamiento informático, su transmisión o su copia, ya sea para uso público o privado, sin permiso de NAMCO EUROPE LIMITED.

Si bien la información contenida en este manual se da de buena fe y es correcta en el momento de su impresión, NAMCO EUROPE LIMITED se reserva el derecho de hacer cambios y alteraciones sin previo aviso.

Esta máquina ha sido fabricada según las directrices de la Comunidad Europea, ha sido probada, y se ajusta a las directrices 89/336/EEC y 72/23/EEC, mediante la aplicación de los estándares EN55014-1, EN55014-2 y EN60334-2-82 (véase cubierta del manual) y por ende lleva el sello de la C.E. Cualquier cambio o modificación que se haga a esta máquina ha de ajustarse a las directrices de la Comunidad Europea. Cualquier cambio no autorizado hecho al producto pudiera contravenir estas directrices.

Bajo ciertas condiciones de extrema interferencia externa, p. ej. transmisiones de radio, descargas electrostáticas u oscilaciones de la red eléctrica puede tener lugar un descenso del rendimiento. No obstante, la máquina recuperará su rendimiento normal una vez que la fuente de interferencias sea retirada o cese de producirlas.

Nota: Si el procesador de juegos se reinicializa a causa de caídas o interrupciones en la alimentación eléctrica, se perderán todos los créditos.

Este juego no se ajusta a la definición de máquina de la Normativa de Maquinaria 89/392/EEC

AVISOS DE SEGURIDAD.

Para utilizar esta máquina con seguridad, lea cuidadosamente este Manual de Operador antes de proceder a la instalación, ajuste o uso de esta máquina.

Cada vez que el propietario de esta máquina confíe a terceros su desmontaje, instalación, ajuste o mantenimiento rutinario deberá asegurarse de que tales personas lean las precauciones adecuadas y las secciones relevantes de este manual antes de comenzar su trabajo.

Para que no ocurra accidente alguno mientras la máquina se encuentre en funcionamiento, siga estrictamente las notas de seguridad tal como más adelante se describen.

Este manual, junto con el Manual de Instalación (cuando proceda), forma parte integral del equipo y debe estar a disposición del personal de mantenimiento y operación en todo momento.

Esta máquina es únicamente para ser usada en interiores, y sólo debe usarse para aquello para lo que ha sido creada.

Namco Ltd. queda exenta de cualquier responsabilidad por accidentes, heridas o daños causados por cambios no autorizados o uso indebido de esta máquina.











NOTAS DE SEGURIDAD.

En este manual se usan las notas siguientes. Familiarícese con cada una de ellas y su significado antes de instalar, revisar, o hacer ajustes en esta máquina.

AVISO.  **Aviso señala un riesgo que puede ocasionar lesiones o la muerte. Tras ver esta nota, no continúe hasta entender completamente y cumplir las condiciones exigidas.**

PRECAUCIÓN.  Precaución señala un riesgo que puede ocasionar daños a la máquina. Tras ver

CONSIDERACIONES GENERALES DE SEGURIDAD.

-  **Opere sólo con esta máquina tras comprobar que ha sido instalada correctamente y de acuerdo con este manual.**
-  **Las notas de aviso deben mantenerse siempre en buen estado y reemplazarse si estuvieran desgastadas para que los usuarios puedan leerlas con claridad.**
-  **Si hubiera algún error o problema con la máquina, debe interrumpirse su operación inmediatamente, y subsanar el problema antes de volver a usarla.**
-  **Las revisiones de instalación, los ajustes, y el mantenimiento rutinario deberán llevarse a cabo sólo por personal cualificado.**
-  **Para asegurar una continua protección contra riesgo de incendios, asegúrese de que los fusibles eléctricos sean reemplazados solamente por otros del mismo tipo y especificaciones. El uso de otros fusibles o material está prohibido.**
-  **La fuente de alimentación del monitor se mantiene caliente, y tiene zonas de alto voltaje incluso cuando la máquina ha sido desconectada, existiendo el riesgo de quemaduras y descargas eléctricas. Tenga cuidado de no tocar estas zonas.**
-  **Para evitar posibles descargas eléctricas por cortes, esta máquina debe estar provista de un enchufe debidamente conectado, con TOMA DE TIERRA.**
-  **Si en cualquier momento el cable de alimentación se dañara, deberá ser reemplazado inmediatamente.**
-  **No encienda el interruptor de la máquina hasta que ésta haya sido correctamente instalada.**
-  **Antes de enchufar la máquina a la red eléctrica, asegúrese de que la máquina está preparada para el voltaje correcto, y de que se usan los fusibles adecuados.**

NOTAS DE INSTALACIÓN.

- ⚠ **JAMÁS ENCIENDA** la máquina antes de haber completado la instalación.
- ⚠ **Para evitar posibles descargas eléctricas, asegúrese de que la máquina está conectada a la red con un enchufe provisto de toma de tierra.**
- ⚠ Para que los usuarios no sufran lesiones debido al movimiento del juego, asegúrese de que hay al menos 500 mm de separación entre éste y otras máquinas o las paredes.
- ⓘ Para evitar daños a la máquina causados por operación incorrecta, asegúrese de que el voltaje de la red es de 230 voltios, corriente alterna.

Notas : Si el lugar donde se instalará la máquina tiene un piso pulido, se recomienda colocar tacos de goma bajo los ajustadores de nivel para evitar que la máquina se deslice por el suelo.

Notas : Para acceder a las unidades de Fuente de Alimentación y CPU, asegúrese de que la parte trasera del mueble principal está separada de muros u otras máquinas al menos 500 mm.

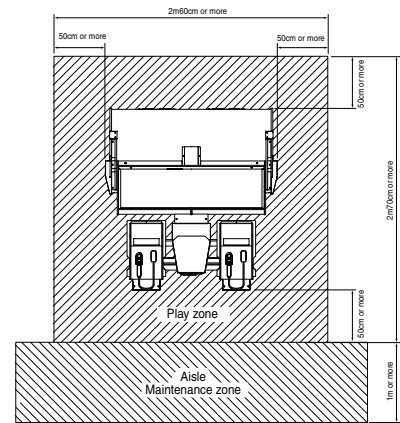

- ⚠ **El juego tiene ruedecitas para hacer más fácil su traslado. Tenga cuidado al mover la máquina en una superficie inclinada.**
- ⚠ **La Unidad de Igualación tiene el centro de gravedad desplazado hacia adelante. Es importante que su montaje y desmontaje se haga por al menos dos personas.**
- ⚠ **La posición de la Unidad de Igualación es bastante alta, y es importante que haya un medio de alcanzar su altura con seguridad, sin estirarse (p. ej. una escalera, un taburete, etc.)**
- ⚠ **La altura total de la Unidad principal es de 2220mm. Tenga cuidado de que no haya obstáculos p. ej. luces.**

RETIRAR Y REEMPLAZAR PARTES Y UNIDADES.

- ⚠ Las revisiones de instalación, los ajustes, y el mantenimiento rutinario deberán llevarse a cabo sólo por personal cualificado.
- ⚠ No realice alteraciones en esta máquina sin aprobación previa. De hacerlo así, pueden causar peligros imprevisibles.
- ⚠ Sólo deben usarse las partes especificadas por Namco Europe Ltd. para reparaciones o reemplazos (incluidos los tornillos).
- ⚠ Asegúrese de que la máquina está desconectada antes de comenzar cualquier trabajo de mantenimiento (reparaciones, resolución de problemas, etc.)
- ⚠ Al realizar trabajos no descritos en este manual, póngase en contacto con su distribuidor para recibir instrucciones. Se declina cualquier responsabilidad por daños o lesiones.
- ⚠ Hay partes de la fuente de alimentación y del monitor que se mantienen calientes o almacenan alto voltaje incluso tras desconectar la máquina, y pueden producir quemaduras o descargas eléctricas. Tenga cuidado de no tocar accidentalmente estas partes.
- ⚠ Asegúrese de que la máquina está apagada antes de conectar o desconectar cualquier enchufe o conector.
- ⚠ Al retirar el conector principal de la máquina, o la clavija de alimentación del enchufe de la red, agarre siempre la clavija y no el cable.

Aucun élément de cette publication ne sera reproduit, ni par procédé mécanique, photographique ou électronique, ni par un moyen d'enregistrement phonographique. Ces informations ne seront ni stockées grâce à un procédé de récupération, ni transmises ou autrement copiées pour un usage public ou privé, sans l'autorisation de **NAMCO EUROPE LIMITED**.

Malgré le fait que les informations contenues dans ce manuel soient données de bonne foi et étaient actualisées au moment de leur impression, NAMCO EUROPE LIMITED se réserve le droit de procéder à des changements ou à des modifications sans avis préliminaire.

Ce jeu a été fabriqué en respect des normes de la Communauté Européenne, après avoir été testé il répond aux normes 89/336/EEC et 72/23/EEC, en application des standards EN55014-1, EN55014-2 et EN60334-2-82 (voir la couverture du manuel), et comme tel il comporte l'autocollant de conformité avec les normes de la Communauté Européenne. Tout changement non autorisé sur ce produit pourrait contrevenir à ces normes.

Sous certaines conditions extrêmes d'interférence externe, par exemple des transmissions radio, des décharges électrostatiques ou bien de interférences passagères sur le réseau, certaines dégradations ou anomalies peuvent se produire. Le jeu retrouvera cependant son état normal de fonctionnement lorsque la cause de ces anomalies aura cessé ou se trouvera déplacée.

Note:-

Si le processeur du jeu se reprogramme suite à une interruption ou une réduction de l'alimentation, les crédits qu'il aurait pu contenir peuvent se trouver perdus.

Ce jeu n'est pas une machine, telle que définie par la norme sur les machines 89/392/EEC

MESURES DE SECURITE

Afin d'utiliser ce jeu en toute sécurité, bien lire ce manuel d'utilisation avant de procéder à son installation, son réglage ou son exploitation.

Si le propriétaire de ce jeu en confie la démontage, l'installation, le réglage ou la maintenance habituelle à une autre personne, il devra s'assurer que cette personne ait lu les conseils d'utilisation et les passages du manuel se rapportant à ce thème, avant qu'elle ne commence son travail.

Afin d'éviter tout accident pendant la durée d'exploitation de ce jeu, se conformer strictment aux conseils de sécurité décrits à la suite.

Ce manuel ainsi que le manuel d'installation du jeu (là où nécessaire) font partie des éléments nécessaires à l'installation de la machine et doivent être mis à la disposition de l'utilisateur et du personnel de maintenance à tout moment.

Ce jeu est uniquement destiné à un usage intérieur et devra être utilisé comme tel.

Namco Ltd. ne sera aucunement tenu responsable en cas d'accidents, de blessure ou de dommage quelconque résultant de modifications non autorisées ou d'usage impropre du jeu.











REMARQUES SUR LA SECURITE

Les termes de sécurité détaillés à la suite seront utilisés tout au long de la lecture de ce manuel. Il convient de vous familiariser avec chacun de ces termes ainsi que leur signification avant de procéder à l'installation, à la maintenance ou au réglage du jeu.

AVERTISSEMENT  Ce terme annonce un danger qui pourrait éventuellement avoir des conséquences dommageables ou mortelles. **Ne pas passer outre ce signal jusqu'à ce que les conditions indiquées soient entièrement comprises et effectuées.**

ATTENTION  Ce terme indique qu'un danger menace la machine. **Ne pas passer outre ce signal jusqu'à ce que les conditions indiquées soient entièrement comprises et effectuées.**

CONSIGNES GENERALES DE SECURITE

-  **Allumer l'appareil seulement après avoir vérifié qu'il a été correctement installé, et que les instructions du manuel ont été respectées.**
-  **Les notes de mise en garde doivent constamment demeurer en bon état et être remplacées en cas de disparition, afin que le client puisse les lire clairement.**
-  **S'il y a une erreur ou un problème avec la machine, l'utilisation doit être immédiatement interrompue et le problème résolu avant toute nouvelle utilisation.**
-  **L'installation, le service, le réglage, ou la maintenance doivent être effectués uniquement par les personnes qualifiées.**
-  **Afin d'éviter un éventuel incendie, s'assurer que les fusibles soient remplacés par le même type de fusibles et au bon voltage. L'utilisation d'autres sortes de fusibles ou autres matériels est interdite.**
-  **L'alimentation à l'intérieur du moniteur reste chaude et comporte des zones de haute tension même si la machine est éteinte. Il existe donc un risque de brûlure ou d'électrocution. Attention à ne pas toucher ces endroits.**
-  **Pour prévenir une éventuelle électrocution due à un défaut matériel, ce jeu DOIT être muni d'une prise de TERRE connectée en toute sécurité**
-  **Si à tout moment les fils électriques sont endommagés, il faut les remplacer immédiatement**
-  **Ne pas mettre le jeu en mode de fonctionnement avant qu'il n'ait été correctement installé.**
-  Avant de connecter la machine au réseau, s'assurer que la machine est installée sous la bonne tension et que les fusibles correspondent.

NOTES D'INSTALLATION

- ⚠ **NE JAMAIS** mettre le jeu en marche avant que l'installation ne soit complètement effectuée.
- ⚠ Afin de prévenir une éventuelle électrocution, s'assurer que la machine est connectée au réseau avec une prise de terre reliée selon les normes de sécurité.
- ⚠ Afin que les clients ne soient pas blessés par les mouvements du jeu, s'assurer qu'il existe au moins 500 mm de séparation avec les autres jeux ou les murs.
- ⓘ Afin d'éviter que la machine ne soit abimée suite à une mauvaise opération, s'assurer que la tension sur le réseau principal soit de 230 volts AC.

Note: Si l'endroit où doit être installée la machine à un sol pöli, il est recommandé de poser des tampons feutrés sous les vérins pour éviter que le jeu ne glisse sur le sol

Note: Afin de faciliter l'accès aux CPU et à l'alimentation, s'assurer qu'il y a un espace d'au moins 500 mm entre l'arrière du meuble et le mur ou tout autre jeu.

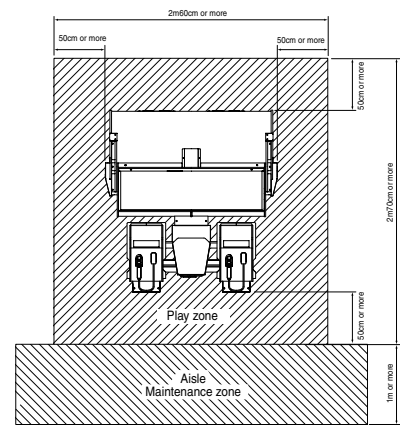

- ⚠ Le jeu est fourni avec des roulettes pour une meilleure mobilité. Prendre garde quand la machine est déplacée sur une surface inclinée.
- ⚠ Le centre de gravité de la partie supérieure du jeu est situé sur l'avant, il est donc indispensable que deux personnes au moins soient employées pour installer ou déplacer la partie supérieure.
- ⚠ L'installation de la partie supérieure du jeu s'effectue en hauteur, il est donc important d'utiliser un élévateur quelconque pour en effectuer le montage.
- ⚠ La hauteur totale de l'assemblage principal est de 2220 mm, prendre garde aux encombrements de la partie supérieure (ex : illuminations du bandeau).

DEPLACER ET REMPLACER LES UNITES ET LES PIECES DETACHEES.

- ⚠ L'installation, le service, le réglage, ou la maintenance doivent être effectués uniquement par les personnes qualifiées.
- ⚠ Ne pas apporter de modifications sur cette machine sans autorisation préalable, faute de quoi cela pourrait entraîner un danger.
- ⚠ Seules les pièces détachées Namco Europe Ltd. doivent être utilisées pour le remplacement ou la réparation de pièces (y compris les vis)
- ⚠ S'assurer que l'interrupteur soit sur OFF avant de commencer tout travail de maintenance (localisation d'une panne, réparations, etc.)
- ⚠ Si dans ce manuel il manque une information pour réaliser un quelconque travail, contacter votre distributeur, car aucune responsabilité ne sera acceptée en cas de dommage ou de blessure.
- ⚠ Les pièces de l'alimentation et du moniteur restent chaudes, à tension élevée même lorsque la machine est hors tension, elle pourrait occasionner des brûlures ou des électrocutions. Attention de ne pas toucher ces endroits accidentellement.
- ⚠ S'assurer que la machine soit hors tension avant de brancher ou débrancher toute prise ou connecteur.
- ⚠ Lorsque l'on manipule la prise au réseau de la machine, ou lorsque les prises principales doivent être débranchées, saisir toujours la prise, et non le câble.



Κανένα μέρος αυτής της έκδοσης δεν μπορεί να αναπαραχθεί με οποιοδήποτε μηχανικό, φωτογραφικό ή ηλεκτρονικό μέσο, ή με μορφή φωνητικής ηχογράφησης και ούτε να αποθηκευτεί με επανορθωτικό σύστημα, να μεταδοθεί ή να αντιγραφεί για δημόσια ή ιδιωτική χρήση, χωρίς την άδεια της NAMCO EUROPE LIMITED.

Καθώς αυτές οι πληροφορίες σε αυτό το εγχειρίδιο έχουν δοθεί με καλή πίστη και ακριβώς την ώρα της τύπωσης, η εταιρεία NAMCO EUROPE LIMITED κρατάει το δικαίωμα να κάνει οποιεσδήποτε αλλαγές χωρίς ειδοποίηση.

Τα μηχανήματα έχουν κατασκευαστεί σύμφωνα με τους όρους της Ευρωπαϊκής Κοινότητας, και έχουν ελεγχθεί σύμφωνα με τους νόμους 89/336/ΕΟΚ και 72/23/ΕΟΚ με την αίτηση των EN55014-1, EN55014-2 και EN60334-2-82 στάνταρτς (δες μπροστά στο εγχειρίδιο) και όλα έχουν το CE σήμα. Οποιαδήποτε αλλαγή ή μετατροπή σε αυτό το μηχάνημα πρέπει να είναι σύμφωνα με τους όρους της Ευρωπαϊκής Κοινότητας. Οποιοσδήποτε αλλαγές χωρίς άδεια σε αυτό το προϊόν μπορεί να παραβεί αυτούς τους όρους.

Σε κάποιες περιπτώσεις υπερβολικής εξωτερικής παρεμβολής, π.χ. ραδιοφωνικές μεταδόσεις, ηλεκτροστατικές μεταβολές ή παροδικές εμβολές, μπορεί να παρουσιαστούν κάποιες αθλιότητες στην παρουσίαση. Πάντως το μηχάνημα θα επανέλθει στην φυσιολογική παρουσίαση εφ' όσον η πηγή της παρεμβολής σταματήσει ή απομακρυνθεί.

Σημείωση: Εάν γίνει reset στον processor του μηχανήματος κατά τη διάρκεια της κύριας παροχής, πόντοι που έχουν κερδηθεί μπορεί να χαθούν.

Αυτό το παιχνίδι δεν είναι μηχάνημα όπως προσδιορίζεται από τους όρους Μηχανημάτων 89/392/ΕΟΚ.

ΟΔΗΓΙΕΣ ΑΣΦΑΛΕΙΑΣ

Για την ασφαλή χρήση του μηχανήματος, πρέπει να διαβάσεις το εγχειρίδιο χρήσης προσεκτικά πριν την εγκατάσταση, τοποθέτηση ή χρήση του μηχανήματος.

Οποιοδήποτε ο ιδιοκτήτης αυτού του μηχανήματος ζητάει από κάποιο πρόσωπο να εγκαταστήσει, να κάνει οποιαδήποτε αλλαγή ή έλεγχο ρουτίνας στο μηχάνημα, πρέπει να είναι σίγουρος ότι έχει διαβάσει τις οδηγίες αυτού του εγχειριδίου πριν να αρχίσει να δουλεύει.

Προς αποφυγήν οποιοσδήποτε ατυχήματος κατά την λειτουργία του μηχανήματος, αυστηρώς ακολουθούνται οι οδηγίες ασφάλειας όπως δίνονται παρακάτω.

Αυτό το εγχειρίδιο σε συνδυασμό με το εγχειρίδιο εγκατάστασης (όπου διατίθεται) αποτελεί ένα ολοκληρωμένο μέρος των παροχών και πρέπει να είναι διαθέσιμο για την λειτουργία και το service οποιαδήποτε στιγμή.

Αυτό το μηχάνημα είναι για χρήση μόνο σε εσωτερικό χώρο και θα πρέπει να χρησιμοποιείται μόνο για τους λόγους για τους οποίους κατασκευάστηκε.

Η εταιρεία NAMCO Ltd δεν φέρει καμία ευθύνη για ατυχήματα, πληγές ή καταστροφές που μπορεί να προκληθούν από αλλαγές χωρίς άδεια σε ή εισαγωγείς αυτού του μηχανήματος.

ΣΗΜΕΙΩΣΕΙΣ ΑΣΦΑΛΕΙΑΣ

Οι ακόλουθες σημειώσεις ασφάλειας χρησιμοποιούνται μέσω αυτού του εγχειριδίου. Διάβασε αυτές προσεκτικά για να γίνει κατανοητό το νόημά τους πριν την εγκατάσταση, σέρβις ή οποιαδήποτε αλλαγή γίνει στο μηχάνημα.

ΠΡΟΕΙΔΟΠΟΙΗΣΗ ⚠

Η προειδοποίηση αφορά κίνδυνο ο οποίος μπορεί να είναι λόγος θανάτου. Να μην προχωρήσεις σε οποιαδήποτε κίνηση μέχρι αυτοί οι όροι γίνουν κατανοητοί.

ΠΡΟΣΟΧΗ ⓘ

Η προσοχή αφορά κίνδυνο ο οποίος μπορεί να προκαλέσει πρόβλημα στο μηχάνημα. Να μην προχωρήσεις σε οποιαδήποτε κίνηση μέχρι αυτοί οι όροι γίνουν κατανοητοί.

ΕΞΕΤΑΣΗ ΓΕΝΙΚΗΣ ΑΣΦΑΛΕΙΑΣ

- ⚠ **Αφού έχει κατανοηθεί αυτό το εγχειρίδιο, μόνο τότε να λειτουργήσει το μηχάνημα ή να γίνει έλεγχος εφ' όσον έχει γίνει η εγκατάσταση.**
- ⚠ **Οι προειδοποιήσεις πρέπει να μένουν καθαρές και σε καλή κατάσταση ώστε ο πελάτης να τις διαβάζει καθαρά.**
- ⚠ **Εάν υπάρχει λάθος ή πρόβλημα με το μηχάνημα, η λειτουργία πρέπει να σταματάει αμέσως και να διορθώνεται το λάθος πριν οποιαδήποτε άλλη χρήση.**
- ⚠ **Εγκατάσταση, μετατροπή ή έλεγχος ρουτίνας μπορεί να γίνεται μόνο από εξουσιοδοτημένα άτομα.**
- ⚠ **Για συνεχή προστασία από φωτιά, πρέπει οι ασφάλειες να αντικαθιστούνται με ίδιου τύπου. Η χρήση άλλων ασφαλειών ή αντικειμένων απαγορεύεται.**
- ⚠ **Το τροφοδοτικό στο εσωτερικό του μηχανήματος θα παραμείνει ζεστό και υπάρχουν περιοχές με υψηλή τάση πα' όλο που το μηχάνημα δεν δουλεύει, και υπάρχει η πιθανότητα ηλεκτρικού σοκ. Προσοχή να μην ακουμπήσεις αυτές τις περιοχές.**
- ⚠ **Για την αποφυγή ηλεκτρικών σοκ λόγω βλάβης, το μηχάνημα ΠΡΕΠΕΙ να έχει πρώτα ενωθεί με γείωση.**
- ⚠ **Εάν κάποια στιγμή καταστραφεί η κύρια παροχή, πρέπει να αντικατασταθεί αμέσως.**
- ⚠ **Να μην ανάψει το μηχάνημα (switch ON) μέχρι να έχει εγκατασταθεί σωστά και πλήρως.**
- ⓘ **Πριν την παροχή ρεύματος στο μηχάνημα, να είσαι σίγουρος ότι τα voltage και όλες οι ασφάλειες είναι σωστά ενωμένα και τοποθετημένα.**

ΣΗΜΕΙΩΣΕΙΣ ΓΙΑ ΤΗΝ ΕΓΚΑΤΑΣΤΑΣΗ

- ⚠ ΠΟΤΕ να μην ανάβει το μηχάνημα εάν δεν έχει ολοκληρωθεί η εγκατάσταση.
- ⚠ Για την αποφυγή ηλεκτρικών σοκ πρέπει το μηχάνημα να έχει γειωθεί.
- ⚠ Για την αποφυγή κινδύνου σε κάποιον παίκτη , πρέπει το μηχάνημα να έχει απόσταση τουλάχιστον 500mm από άλλο μηχάνημα ή τοίχο.
- ⓘ Για την αποφυγή βλάβης στο μηχάνημα λόγω λάθος λειτουργίας , πρέπει η παροχή να είναι 230volt AC..

ΣΗΜΕΙΩΣΗ: Εάν το πάτωμα στο οποίο είναι τοποθετημένο το μηχάνημα γλιστράει, είναι καλό να μπει ένα κομμάτι μοκέτας για αποφυγή μετακίνησης του μηχανήματος εν ώρα λειτουργίας του.

ΣΗΜΕΙΩΣΗ: Για την εύκολη πρόσβαση στην κυρίως παροχή ή το CPU πρέπει η πίσω πόρτα του μηχανήματος να απέχει τουλάχιστον 500mm από τον τοίχο ή άλλο μηχάνημα.

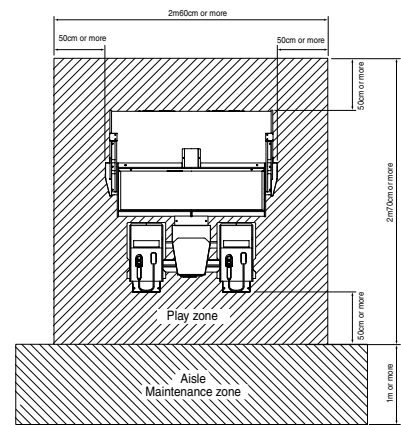

- ⚠ Το μηχάνημα είναι εφοδιασμένο με καρούλια για την εύκολη μετακίνησή του.
- ⚠ Το επάνω μέρος του μηχανήματος έχει επιπλέον βάρος γιαυτό χρειάζονται δύο για την μεταφορά.
- ⚠ Η κεφαλή (καπάκι) του μηχανήματος είναι πολύ ψηλό και γιαυτό χρειάζεται προσοχή στην τοποθέτησή του , να μην χτυπήσει ή καταστραφεί.
- ⚠ Το συνολικό ύψος της κεφαλής είναι 2220mm . Φρόντισε να μην χτυπήσει σε λάμπες κ.λ.π.

ΑΠΟΜΑΚΡΥΝΣΗ ΚΑΙ ΑΝΤΙΚΑΤΑΣΤΑΣΗ ΜΕΡΩΝ - ΑΝΤΑΛΛΑΚΤΙΚΩΝ

- ⚠ Εγκατάσταση , μετατροπή ή έλεγχος ρουτίνας μπορεί να γίνεται μόνο από εξουσιοδοτημένα άτομα .
- ⚠ Δεν πρέπει να γίνονται μετατροπές στα μηχανήματα ωρίς έγκριση . Μπορεί να προκληθεί απρόβλεπτος κίνδυνος.
- ⚠ Μόνο μέρη που διευκρινίζονται από την εταιρεία NAMCO EUROPE Ltd μπορούν να χρησιμοποιηθούν για αντικατάσταση ή επιδιόρθωση. (συμπεριλαμβάνοντε και οι βίδες)
- ⚠ Να είναι σίγουρα κλειστό το ρεύμα πριν οποιαδήποτε δουλειά στο μηχάνημα.
- ⚠ Εάν γίνει κάποια δουλειά στο μηχάνημα χωρίς να διευκρινίζεται στο εγχειρίδιο , να επικοινωνήσεις με τον αντιπρόσωπο για οδηγίες γιατί καμία ευθύνη δεν φέρουμε για καταστροφές ή βλάβες.
- ⚠ Μέρη του τροφοδοτικού ή του μόνιτορ παραμένουν ζεστά ή έχουν υψηλή τάση ακόμα και όταν σβήσει το μηχάνημα και μπορούν να προκαλέσουν κάψιμο ή ηλεκτροσόκ. Γιαυτό δεν πρέπει να έρχονται σε επαφή με χέρια .
- ⚠ Το μηχάνημα πρέπει να είναι σβηστό κατά την σύνδεση ή αποσύνδεση πρίζας ή κονέκτορα.
- ⚠ Κατά την απομάκρυνση των κεντρικών κονέκτορ από το μηχάνημα ή της κυρίας πρίζας , πρέπει να πιάνουμε το πλαστικό μέρος και όχι το καλώδιο.



Nessuna parte di questa pubblicazione può essere riprodotta con processo meccanico, fotografico o elettronico, nè sotto forma di registrazione fonografica, nè può essere memorizzata in un sistema di salvataggio, trasmessa o in altro modo copiata per uso pubblico o privato, senza l'autorizzazione di **NAMCO EUROPE LIMITED**.

Le informazioni contenute in questo manuale sono state date in buona fede ed erano accurate al momento della pubblicazione. Tuttavia NAMCO EUROPE LIMITED, si riserva il diritto di apporre cambiamenti e variazioni senza alcun preavviso.

Questo apparecchio è stato costruito in conformità alle Direttive della Comunità Europea, ed è stato provato e soddisfa le Direttive 89/336/EEC e 72/23/EEC per l'applicazione degli standards delle norme EN55014-1, EN55014-2 e EN60334-2-82 (vedi fronte del manuale), e per questo porta il marchio CE. Qualsiasi cambiamento o modifica di questo apparecchio deve essere in conformità con le Direttive della Comunità Europea.

In caso di condizioni di estrema interferenza dall'esterno, per esempio trasmissioni radio, scariche elettrostatiche o transitori sulla linea, può verificarsi un decadimento delle prestazioni. Comunque l'apparecchio ritornerà al rendimento normale quando la sorgente dell'interferenza avrà cessato di emettere o sarà stata rimossa.

Nota bene: se il processore del gioco "resetta" a causa di una interruzione o diminuzione del voltaggio di linea, un eventuale credito, già concesso, può essere annullato.

Questo gioco non è una macchina così come viene definita dalla Direttiva Macchine 89/392/EEC.

AVVERTENZE PER LA SICUREZZA

Allo scopo di usare questo apparecchio in sicurezza, leggere questo Manuale dell'operatore attentamente prima dell'installazione, regolazione o uso di questa macchina.

Tutte le volte che il proprietario di questo apparecchio affida lo smontaggio, l'installazione, la regolazione o la manutenzione ordinaria ad un'altra persona, il proprietario stesso deve assicurarsi che quella persona legga le precauzioni necessarie e i paragrafi importanti di questo manuale prima di iniziare a lavorare.

Perchè non succeda alcun incidente quando la macchina è operante, seguire rigorosamente le note sulla sicurezza come specificato più avanti.

Questo manuale insieme con il manuale di installazione (dove si può applicare) forma una parte integrante dell'apparecchio e deve essere disponibile sempre al personale operante e di servizio.

Questa macchina deve essere usata solo in interni e deve essere usata solo per gli scopi per cui è progettata.

Namco Europe Ltd non si assume responsabilità per incidenti, ferite o danni risultanti da cambiamenti non autorizzati o da uso improprio della macchina.











NOTE PER LA SICUREZZA

Le seguenti note sulla sicurezza sono usate dal principio alla fine di questo manuale. Valutare attentamente ciascuna di queste note ed il loro significato prima di installare, fare assistenza o regolazioni su questa macchina.

WARNING  "Warning" evidenzia un rischio di ferita o di morte. Non procedere oltre una nota "Warning" finchè le avvertenze specificate non siano completamente capite e conosciute.

CAUTION  "Caution" evidenzia un rischio di danneggiare la macchina. Non procedere oltre una nota "Caution" finchè le avvertenze specificate non siano completamente capite e conosciute.

CONSIDERAZIONI GENERALI SULLA SICUREZZA

-  **Mettere in funzione l'apparecchio solo dopo aver controllato che l'installazione sia stata effettuata correttamente ed in conformità alle istruzioni del manuale.**
-  **Gli avvisi "Warning" devono sempre essere conservati in buone condizioni e sostituiti se consumati, cosicché il cliente li possa leggere chiaramente.**
-  **Se vi sono errori o problemi con la macchina, si deve interrompere il funzionamento immediatamente e risolvere il problema prima di ogni ulteriore uso.**
-  **L'installazione, l'assistenza, le regolazioni e la manutenzione ordinaria devono essere eseguite solo da persone idonee e qualificate.**
-  **Per una protezione costante contro il rischio di fuoco, assicurarsi che i fusibili sulle alimentazioni siano solo sostituiti con lo stesso tipo e caratteristiche. L'uso di altri fusibili o materiali è proibito.**
-  **L'alimentatore all'interno del monitor rimane caldo ed ha zone di alto voltaggio anche se la macchina è stata spenta, c'è quindi la possibilità di bruciature o scosse elettriche. Fare attenzione a non toccare queste zone.**
-  **Per prevenire possibili scosse elettriche dovute a difetti, questa macchina DEVE essere installata con un connettore sicuramente MESSO A TERRA.**
-  **In caso il cavo di alimentazione di rete risultasse danneggiato deve essere sostituito immediatamente.**
-  **Non accendere la macchina finchè la stessa non è stata installata completamente e correttamente.**
-  **Prima di collegare la macchina alla rete, assicurarsi che la macchina sia preparata per il voltaggio corretto e che siano inseriti i fusibili adatti.**

NOTES D'INSTALLATION

- ⚠ **NON ACCENDERE MAI** la macchina finchè l'installazione non è stata completata.
- ⚠ Allo scopo di prevenire possibili scosse elettriche, la macchina deve essere obbligatoriamente collegata alla rete con un connettore messo a terra con connessioni sicure.
- ⚠ Perché i clienti non siano feriti dal movimento del gioco, assicurarsi che ci siano almeno 500mm di distanza rispetto alle altre macchine o rispetto al muro.
- ⓘ Per evitare danni alla macchina durante la messa in opera, assicurarsi che il voltaggio della rete sia 230 volts AC.

Note: Il luogo di destinazione della macchina deve avere il pavimento liscio e si raccomanda di sistemare dei cuscinetti di gomma sotto i piedini di livellamento per prevenire lo scivolamento della macchina sul pavimento.

Note: Per garantire l'accesso all'alimentatore e alla scheda madre, assicurarsi che il retro del mobile principale sia separato dalla parete o da altre macchine di almeno 500mm.

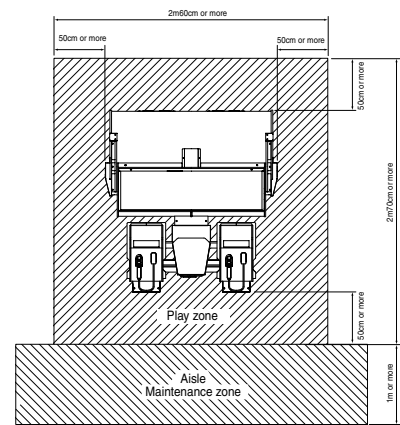

- ⚠ Il gioco è fornito di ruote per rendere più facile il suo spostamento. Fare attenzione quando si muove la macchina su una superficie inclinata.
- ⚠ La testata ha il baricentro spostato in avanti, è perciò importante che ci siano almeno 2 persone per montare o smontare la testata stessa.
- ⚠ La posizione di fissaggio della testata è molto alta, ed è importante che ci sia un mezzo disponibile per raggiungere tale altezza in sicurezza e senza allungamenti. (Ad esempio scalini, scale portatili etc.)
- ⚠ L'altezza totale della parte principale è 2220mm, fare attenzione ad eventuali ostacoli sopra la testata ovvero ad eventuali installazioni di luci.

RIMOZIONE E SOSTITUZIONE DI GRUPPI E PARTI STACCATE

- ⚠ L'installazione, l'assistenza, le regolazioni e la manutenzione ordinaria devono essere eseguite solo da persone idonee e qualificate.
- ⚠ Non apporre alcuna modifica alla macchina senza autorizzazione preventiva. Il fare questo può causare un pericolo non prevedibile.
- ⚠ Quando si rimpiazza o si riparano delle parti (incluse le viti) si possono usare solo parti approvate dalla Namco Europe Ltd.
- ⚠ Assicurarsi che la macchina sia SPENTA prima di incominciare qualsiasi lavoro di manutenzione (guasti, riparazioni etc.)
- ⚠ Se state per iniziare un lavoro non descritto in questo manuale, contattate il vostro distributore per istruzioni poiché non si accetta alcuna responsabilità per danni o ferite.
- ⚠ Parti dell'alimentatore e del monitor rimangono caldi o portano alta tensione anche dopo aver spento l'apparecchiatura e possono causare bruciate o scosse elettriche. Attenzione a non toccare queste parti accidentalmente.
- ⚠ Assicurarsi che la macchina abbia l'interruttore nella posizione OFF prima di inserire o disinserire qualsiasi connettore o spina.
- ⚠ Quando vengono rimossi i connettori principali dalla macchina oppure la spina dell'alimentazione dalla parete bisogna sempre afferrare il connettore e non il cavo.



Ingen del av denne utgivelsen må reproduseres av noen mekaniske, fotografiske eller elektroniske prosesser, eller i form av fotografiske opptak, og ikke kan lagres i et gjenvinnbart system, sendt eller kopiert for offentlig eller privat bruk, uten tillatelse fra NAMCO EUROPE LIMITED.

Da informasjonen i denne manualen er gitt i god tru og var korrekt da den ble utgitt, tillegger NAMCO EUROPE LIMITED seg retten til å lage forandringer uten varsel.

Denne maskinen er produsert i samsvar med direktiver framsatt av det Europeiske samfunn. Maskinen er testet og samsvarer med direktivene 89/336/EEC og 72/23/eec med anvendelse av EN55014-1, EN55014-2 og EN60334-2-82 standarder (se i begynnelsen av manualen), og derfor bærer CE merket. Hvilken som helst forandring eller modifisering må skje etter direktivene satt av det Europeiske samfunn. Uautoriserte forandringer på dette produktet, kan motstride disse direktivene.

Under noen forhold av ekstreme ytre forstyrrelser, f.eks radio sendere, elektronisk utladning eller transiente spenninger, kan man regne med noe senket ytelse. Men maskinen vil oppnå normal ytelse når kilden til forstyrrelsene opphører eller er fysisk fjernet.

Merk:- Hvis spilllets prosessor resettes p.g.a et kutt eller reduksjon av hovedspenningen kan oppsparte kreditt på spillet forsvinne.

Dette spillet er ikke en maskin som er definert ved Maskin direktivet 89/392/EEC.

Sikkerhets advarsel.

For å bruke denne maskinen uten noe form for fare, sørg for å lese denne manualen nøye før installasjon, justeringer eller bruk av maskinen.

Når eieren av denne maskinen overlater avmontering, installasjon, justering eller rutine vedlikehold til en annen person, skal eieren forsikre seg om at denne personen leser de passende forsiktighetsreglene og relevante deler av manualen før han starter på arbeidet.

For å forhindre at ulykker inntreffer når maskinen er i drift, følg strengt teksten om sikkerhet som beskrevet nedenfor.

Denne manualen sammen med installasjons manualen (hvor det er anvendelig) er en intrigert del av utstyret og må være tilgjengelig for drift- og servispersonell til alle tider.

Denne maskinen er bare for innendørs bruk og skal bare benyttes etter mente hensikter.

Namco Ltd. bærer intet ansvar ved ulykker, kvestelse eller skade som følge av uautoriserte forandringer, eller for uriktig bruk av maskinen.

Sikkerhets beskjeder.

Følgende sikkerhets punkter er brukt ut denne manualen. Gjør deg kjent med disse punktene og deres mening før installasjon, service eller du utfører noen innstillinger på denne maskinen.

ADVARSEL ⚠ **Advarsel innebærer en risiko som kan føre til kvestelse eller død. Ikke fortsett utover advarslen før den er ordentlig forstått og mottiltak er igangsatt.**

FORSIKTIG ⓘ Forsiktig innebærer en risiko som kan medføre skade på maskinen. Ikke fortsett utover advarslen før den er ordentlig forstått og mottiltak er igangsatt.

VANLIGE SIKKERHETSTILTAK

- ⚠ **Bruk bare denne maskinen etter å ha kontrollert at den er korrekt installert ifølge manualen.**
- ⚠ **Advarsel skiltene må bestandig holdes i skikket stand og eventuelt byttes ut hvis det oppstår skade på dem, slik at kunden uten vanskelighet kan lese dem.**
- ⚠ **Hvis det er en feil eller et problem med maskinen, må den straks settes ut av funksjon. Og må under ingen omstendigheter startes før problemet er rettet på.**
- ⚠ **Installasjon, service, justering eller rutine vedlikehold skal bare utføres av kvalifiserte personer.**
- ⚠ **For fortsatt beskyttelse mot brann, forsikre deg at hoved sikringen bare byttes ut med en av samme type og verdi. Bruk av andre sikringer eller materiale er forbudt.**
- ⚠ **Strømforsyningen inne i monitoren vill være varm og ha områder med høy spenning selv om maskinen har blitt slått av, og det er muligheter for skader og elektriske sjokk. Vær forsiktig så du ikke berører disse områdene.**
- ⚠ **For å forhindre mulige elektriske sjokk grunnet funksjonsfeil, må denne maskinen være ordentlig jordet.**
- ⚠ **Hvis ledningen til hoved strømforsyningen skades må den straks byttes ut.**
- ⚠ **Ikke slå på maskinen før den er korrekt installert.**
- ⓘ **Før du kople maskinen til strømmettet, forsikre deg om at maskinen innstilt for den korrekte spenningen og de riktige sikringene benyttes.**

MERKNADER VED INSTALLASJON

- ⚠ Slå ALDRI på maskinens strømforsyning før installasjonen er fullført.
- ⚠ For å forhindre eventuelle elektriske sjokk, forsikre deg om at maskinen er koplet til et strømnnett med ordentlig jording.
- ⚠ For å forhindre at kundene blir skadet av spillets bevegelige deler, forsikre deg om at det er minst 500mm avstand mellom andre maskiner eller vegger.
- ⓘ For å forhindre skade på maskinen p.g.a. feil bruk, sørg for at spenningen til hoved strømforsyningen er 230Volt AC.

MERKNADER: Hvis plassen hvor spillet skal plasseres har polerte gulv anbefales det at du benytter gummi sko under nivå justeringene, for å forhindre at maskinen kan flytte på seg.

MERKNADER: For å få adgang til strømforsyningen og CPU-kort, forsikre deg om at bakparten av hoved kabinettet er skilt fra vegger eller andre maskiner med minst 500mm.

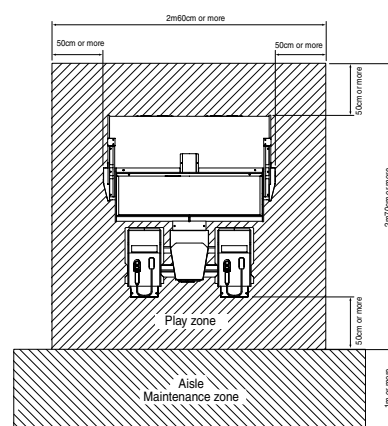

- ⚠ Spillet har montert hjul for å gjøre det letter å flytte på. Hver forsiktig når det skal flyttes på en hellende overflate.
- ⚠ Hoved enheten i spillet har tyngdepunktet i fronten, så det er viktig at minst 2 personer blir brukt til å montere eller flytte denne enheten.
- ⚠ Monterings posisjonen til hoved enheten er veldig høy, og det er viktig at denne høyden nås sikkert, uten at man må strekke seg. Benytt deg av hjelpemiddel. (f.eks sto, krakk, gardintrapp osv)
- ⚠ Den totale høyden på hoved enheten er 2220mm. vær forsiktig med høye hindringer som f.eks lysrør.

FJERNE OG UTSKIFTE ENHETER OG DELER.

- ⚠ Installasjon, service, justering eller rutine vedlikehold skal bare utføres av kvalifiserte personer.
- ⚠ Ikke lag noen forandringer på denne maskinen uten godkjenning. Dette kan medføre uforutsette farer.
- ⚠ Bare deler spesifisert av Namco Europe Ltd. skal benyttes ved utskifting eller reparasjon av deler (dette gjelder også skruer).
- ⚠ Forsikre deg om at strømmen er slått av før du påbegynner noe som helst vedlikeholdsarbeid (feilsøking, reparasjon osv.)
- ⚠ Hvis du utfører arbeid som ikke er beskrevet i denne manualen, ta kontakt med din distributør for instruksjon da ikke noe ansvar vill bli akseptert for skade på maskin eller på personer.
- ⚠ Deler av strømforsyningen og monitoren er fortsatt varm eller bærer høye spenninger selv etter strømmen er slått av og kan forårsake skader eller elektriske sjokk. Forsikre deg om at du ikke berører disse delene.
- ⚠ Forsikre deg om at maskinen er slått av før du kople sammen eller tar fra hverandre pluggen eller koplinger.
- ⚠ Når du fjerner hoved koplingene fra maskinen, eller hoved pluggen fra støpset, ta bestandig tak i pluggen og ikke ledningen.

Niets uit deze publikatie mag worden gereproduceerd door enig mechanisch, fotografisch of elektronisch proces, of in de vorm van een fonografische opname, noch mag het opgeslagen worden in een retrieval systeem, doorgezonden of anderszins gekopieerd voor publiek of privégebruik, zonder toestemming van Namco Europe Limited.

Ofschoon de informatie in deze handleiding in goed vertrouwen is gegeven en nauwkeurig was ten tijde van het drukken, houdt Namco zich het recht voor om veranderingen en aanpassingen te maken zonder bericht.

Deze machine is geproduceerd volgens Richtlijnen van de Europese Gemeenschap, en is getest en is in overeenstemming met de Richtlijnen 89/336/EEC en 72/23/EEC door de toepassing van de standaards EN55014-1, EN55014-2 en EN60334-2-82 (zie voorin de handleiding) en draagt als zodanig het CE-merk. Enige veranderingen of aanpassingen aan deze machine dienen in overeenstemming te zijn met de Richtlijnen van de Europese Gemeenschap. Enige ongeauthoriseerde veranderingen aan dit produkt kunnen in strijd zijn met deze Richtlijnen.

Onder sommige omstandigheden van extreme externe storingen, bijv. radiotransmissies, electrostatische ontladingen of pieken op het net, kan prestatieruggang optreden. De machine zal echter normaal presteren zodra de storingsbron gestopt of verwijderd is.

Let op: - als de spelprocessor reset a.g.v. een onderbreking of vermindering van de netstroom, dan kunnen opgebouwde credits verloren gaan.

Dit spel is niet een machine zoals omschreven in de Machinery Directive 89/392/EEC.

Veiligheidsopmerkingen

Om deze machine veilig te kunnen gebruiken, dient vóór installatie, aanpassing of gebruik van deze machine, de Bedieningshandleiding zorgvuldig gelezen te worden.

Telkens wanneer de eigenaar van deze machine de demontage, installatie, aanpassing of routine-onderhoud toevertrouwd aan een andere persoon, dient de eigenaar er voor te zorgen dat deze persoon de juiste voorzorgsmaatregelen en relevante gedeeltes uit de handleiding leest voordat hij begint.

Om er voor te zorgen dat geen ongelukken gebeuren als de machine gebruikt wordt, dienen onderstaande veiligheidsaanwijzingen zorgvuldig opgevolgd te worden.

Deze handleiding maakt samen met de installatiehandleiding (waar van toepassing) een integraal deel uit van de apparatuur en moet te allen tijde ter beschikking staan van exploitatie- en onderhoudspersoneel.

Deze machine is alleen bedoeld voor gebruik binnenshuis en dient alleen gebruikt te worden voor bedoelde doeleinden.

Namco Ltd. is niet verantwoordelijk voor ongelukken, letsel of schade die voortkomt uit ongeoorloofde veranderingen aan of onjuist gebruik van deze machine.











Veiligheidsopmerkingen

De volgende veiligheidsopmerkingen worden overal in deze handleiding gebruikt. Maak uzelf vertrouwd met deze opmerkingen en hun betekenis vóór installatie, het plegen van onderhoud of het aanbrengen van aanpassingen aan deze machine.

WAARSCHUWING  **Waarschuwing geeft een gevaar aan dat zou kunnen resulteren in letsel of de dood. Ga niet verder dan een waarschuwingsopmerking totdat de aangegeven omstandigheden volledig begrepen zijn en hieraan voldaan is.**

VOORZICHTIG  **Voorzichtig geeft een gevaar aan dat zou kunnen resulteren in schade aan de machine. Ga niet verder dan een voorzichtigheidsopmerking totdat de aangegeven omstandigheden volledig begrepen zijn en hieraan voldaan is**

ALGEMENE VEILIGHEIDSOVERWEGINGEN

-  **Stel deze machine alleen in gebruik nadat gecontroleerd is of de machine correct en overeenkomstig de handleiding is geïnstalleerd.**
-  **De waarschuwingsstickers dienen altijd in goede staat te worden gehouden en vervangen indien versleten, zodat de klant ze goed kan lezen.**
-  **Als zich een fout of probleem voordoet met de machine, dan dient de machine onmiddellijk stopgezet en het probleem verholpen te worden voordat de machine verder gebruikt wordt.**
-  **Installatie, service, aanpassingen of routine-onderhoud dient alleen uitgevoerd te worden door hierin bekwame personen.**
-  **Om blijvende bescherming tegen brandgevaar te garanderen, dient ervoor gezorgd te worden dat de netzekeringen alleen vervangen worden door zekeringen van hetzelfde type en dezelfde sterkte. het gebruik van andere zekeringen of ander materiaal is verboden.**
-  **De voeding in de monitor blijft warm en er kunnen componenten electrisch geladen blijven ondanks dat de machine UITgeschakeld is, waardoor er brandwonden of electrischee schokken kunnen worden opgelopen. Ben voorzichtig en raak deze delen niet aan.**
-  **Om mogelijke electrische schokken a.g.v. storingen te voorkomen, MOET deze machine voorzien zijn van een goed vastzittende aardstekker.**
-  **Mocht het netsnoer op enig moment beschadigd worden, dan moet deze onmiddellijk vervangen worden.**
-  **Zet de machine niet AAN totdat deze correct is geïnstalleerd.**
-  **Voordat de machine op het lichtnet wordt aangesloten, dient gecontroleerd te worden of de machine op het correcte voltage staat afgesteld en of de correcte zekeringen zijn aangebracht.**

Opmerkingen aangaande Installatie

- ⚠ **Sluit de machine nooit aan op de stroomtoevoer totdat de installatie is voltooid.**
- ⚠ Om mogelijke elektrische schokken te voorkomen, dient ervoor gezorgd te worden dat de machine middels een goed vastzittende aardstekker op het lichtnet is aangesloten.
- ⚠ **Om ervoor te zorgen dat klanten niet gewond raken door de beweging van het spel, dient ervoor gezorgd te worden dat er minimaal 500mm ruimte is tussen andere machines of muren.**
- ⓘ Om schade aan de machine door verkeerd gebruik te voorkomen, dient ervoor gezorgd te worden dat het voltage van het lichtnet 230volts AC bedraagt.

OPMERKING: Als de machine op een gladde ondergrond wordt gebruikt, is het raadzaam rubber matjes onder de stelplaatjes te bevestigen om te voorkomen dat de machine over de vloer gaat glijden.

OPMERKING: Om toegang te krijgen tot de voeding- en de CPU-assemblies, dient ervoor gezorgd te worden dat de achterkant van het kabinet minimaal 500mm verwijderd is van de muur of andere machines.

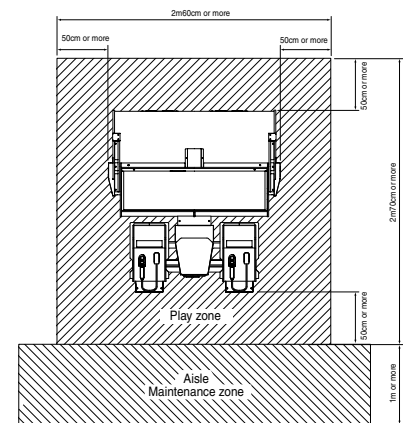

- ⚠ Het spel is voorzien van wieltjes, waardoor het gemakkelijker is om te verplaatsen. Wees voorzichtig als de machine op een hellend vlak gereden wordt.
- ⚠ Het zwaartepunt van de Header Assembly ligt aan diens voorkant, waardoor het belangrijk is dat minimaal 2 personen de Header Assembly aanbrengen of verwijderen.
- ⚠ De Header Assembly moet op een hoge positie geplaatst worden en het is dus belangrijk dat deze hoogte veilig kan worden bereikt zonder veel te strekken. (bijv. middels een trap of een kruk)
- ⚠ De hoogte van het hoofdgedeelte is 2220mm: kijk dus uit voor obstakels zoals lampen.

Verwijderen en vervangen van Assemblies en onderdelen

- ⚠ Installatie, service, aanpassingen of routine-onderhoud dient alleen uitgevoerd te worden door hierin bekwame personen.
- ⚠ Maak geen veranderingen aan deze machine zonder goedkeuring vooraf. Dit kan onvoorzien gevaar opleveren.
- ⚠ Alleen onderdelen die door Namco Europe Ltd. zijn gespecificeerd dienen gebruikt te worden bij het vervangen of repareren van onderdelen (incl. schroeven).
- ⚠ Zorg ervoor dat de machine UITgeschakeld is voordat er enig onderhoudswerk wordt verricht (troubleshooting, reparaties etc.)
- ⚠ Bij het verrichten van werkzaamheden die niet in deze handleiding staan beschreven, dient voor instructies altijd contact opgenomen te worden met de verdeler aangezien geen verantwoording wordt genomen voor schade of letsel.
- ⚠ Delen van de voeding en de monitor blijven warm of behouden hoogspanning zelfs nadat de machine UITgeschakeld is en zouden verbrandingen of elektrische schokken kunnen veroorzaken. Ben voorzichtig en raak deze delen niet per ongeluk aan.
- ⚠ Zorg ervoor dat de machine is UITgeschakeld voordat pluggen of connectors ingestoken of uitgetrokken worden.
- ⚠ Als het netsnoer uit de machine of uit het stopcontact verwijderd wordt, dient altijd de stekker vastgepakt te worden en niet het snoer.



Nenhuma parte desta publicação poderá ser reproduzida por processos mecanográficos, fotográficos, electrónicos ou ainda sob a forma de gravação sonora nem tão pouco poderá ser gravada através de sistemas informáticos transmissíveis ou de outra forma copiados para uso publico ou privado sem autorização expressa da NAMCO EUROPA LIMITADA.

A informação contida neste manual foi fornecida de boa fé, sendo rigorosa na altura da sua publicação. A NAMCO EUROPA LIMITADA, reserva-se o direito de proceder a mudanças e alterações sem qualquer aviso prévio.

Esta maquina foi fabricada de acordo com as Directivas Comunitárias Europeias e tem sido testada em conformidade com as seguintes Directivas: 89/336/EEC e 72/23/EEC através dos requerimentos normativos, EN55014-1, EN55014-2 e EN60334-2-82 (ver capa frontal do manual) e como tal sustenta o certificado de marca de CE. Quaisquier alterações ou modificações efectuadas nesta maquina deverão ser em conformidade com as Directivas da Comunidade Europeia. Quaisquier alterações não autorizadas a este equipamento poderão infringir tais Directivas.

O funcionamento normal desta maquina, poderá ser afectado debaixo de algumas condições extremas de interferências externas tais como; transmissões via radio, descargas electroestáticas e passagens de corrente na rede de alimentação. Contudo o seu funcionamento normal será restabelecido logo que a fonte de interferências tenha cessado ou tenha sido neutralizada.

Nota :- Se o processador de jogo for inicializado devido a uma interrupção ou quebra da corrente principal, quaisquer credits obtidos poderão desaparecer.

Este jogo por si só não constitui uma maquina tal como defenido pelas Directivas de Maquinaria de 89/392/EEC8.

AVISOS DE SEGURANÇA

Afim de usar esta maquina com segurança, certifique-se que lê este manual de operador atentamente antes de proceder à montagem e afinação ou uso da mesma.

Sempre que o proprietário desta maquina confiar a desmontagem, instalação, afinação ou manutenção preventiva da mesma a outra pessoa, deverá este assegurar - se que a pessoa em questão lê as precauções apropriadas e capitulos relevantes deste manual antes de iniciar o trabalho.

Afim de evitar qualquer tipo de acidente quando a maquina estiver em funcionamento, deverá seguir rigorosamente os procedimentos de segurança descritos abaixo.

Este manual juntamente com o manual de instalação (aonde aplicavel), contituem parte integrante do equipamento e deverão estar sempre disponiveis ao operador e pessoal tecnico de assistência.

Esta maquina destina-se a ser operada em espaços interiores apenas e a sua utilização deve circunscrever-se somente aos fins previstos.

A Namco Ltd. declina qualquer responsabilidade por acidentes, ferimentos ou danos resultantes de modificações não autorizadas ou uso indevido desta maquina.

AVISOS DE SEGURANÇA

Os seguintes avisos de segurança são usados através de todo o manual. Familiarize-se com cada um destes avisos e respectivos significados antes de instalar, assistir ou efectuar qualquer afinação nesta maquina.

PERIGO ⚠ **Perigo revela uma situação anormal que poderá resultar em ferimentos ou morte. Não avance para além de um aviso de Perigo sem que todas as condições indicadas estejam completamente esclarecidas e resolvidas.**

CAUTELA ⓘ Cautela revela uma situação anormal que poderá resultar em danos materiais para a maquina. Não avance para além de um aviso de Cautela sem que todas as condições indicadas estejam completamente esclarecidas e resolvidas.

AVISOS DE PERIGO

⚠ **Esta maquina só deverá ser colocada em funcionamento após ter sido verificado que se encontra instalada correctamente e de acordo com o manual de instruções.**

⚠ **Os avisos de perigo devem ser sempre mantidos em boas condições de leitura de forma a permitir uma leitura clara por parte do utilizador, caso se encontrem danificados deverão ser substituídos.**

⚠ **Caso esta maquina manifeste algum erro ou problema durante o seu funcionamento, deverá ser imediatamente parada até que o problema em questão seja rectificado.**

⚠ **A montagem, assistência e afinações ou manutenção de rotina desta maquina, deverão ser somente executadas por tecnicos ou pessoas devidamente qualificadas para o efeito.**

⚠ **Afim de garantir uma protecção anti - fogo permanente nesta maquina, certifique-se que os fusíveis de protecção são sempre substituídos por fusíveis de igual valor ou calibre aos de origem. O uso de outro tipo de fusíveis ou material é proibido.**

⚠ **A fonte de alimentação do monitor encontrar-se-à quente, tendo zonas de alta voltagem, mesmo após a maquina ter sido desligada. Deste facto poderá resultar a ocorrência de queimaduras ou choques electricos. Seja cuidadoso para evitar contacto com estas zonas.**

⚠ **Esta maquina deve estar sempre equipada com uma ficha com circuito de protecção à Terra, afim de evitar possiveis choques electricos, caso surja uma falha no sistema.**

⚠ **Se a qualquer altura o cabo de alimentação principal ficar danificado, deverá ser imediatamente substituído.**

⚠ **Não ligar a maquina sem que esta tenha sido correctamente instalada.**

ⓘ **Antes de ligar a maquina à tomada da rede de alimentação principal, certifique-se de que a maquina está preparada para a voltagem correspondente e de que também se encontra protegida com os fusíveis apropriados.**

NOTAS SOBRE A INSTALAÇÃO

- ⚠ **NUNCA** ligar a maquina sem que a instalação esteja completamente finalizada.
- ⚠ Afim de evitar possiveis choques electricos, certifique-se que a maquina está ligada à rede de alimentação com uma ficha protegida com circuito de terra.
- ⚠ Afim de evitar ferimentos pessoais nos clientes, provocados pelo movimento da maquina, certifique-se que existe pelo menos 500mm de separação entre outras maquinas ou paredes.
- ⓘ Afim de evitar danos na maquina causados por falhas de operação, certifique-se que a voltagem da rede de alimentação principal é de 230volt AC.

NOTAS : Se esta maquina estiver colocada sobre um chão polido, recomenda-se a utilização de tapetes de borracha debaixo dos pés niveladores, afim de prevenir a maquina de deslizar no chão.

NOTAS : Quando precisar de aceder à fonte de alimentação e às placas (CPU), certifique-se que a parte trazeira do móvel central está separada da parede ou de outras maquinas pelo menos 500mm afim de ganhar espaço de manobra.

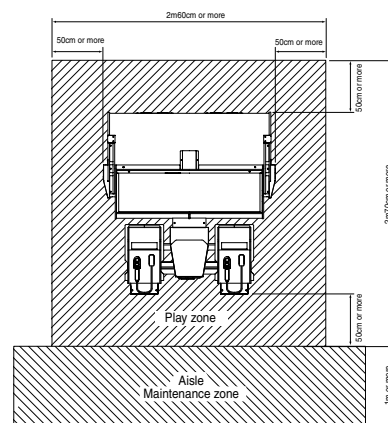

- ⚠ Esta maquina está equipada com rodas afim de facilitar a sua deslocação tenha cuidado ao mover a maquina num plano inclinado.
- ⚠ O bloco Superior (Cabeça) tem o centro de gravidade para a frente, porconsequente é importante que pelo menos sejam utilizadas duas pessoas para montar ou desmontar este Bloco Superior.
- ⚠ A posição do bloco superior quando montado na maquina é muito alta. Torna-se importante ter meios seguros de alcance, tais como; escadotes ou escadas afim de evitar riscos desnecessários.
- ⚠ A altura total do bloco principal, é de 2220mm, tenha cuidado com qualquer tipo de obstruções existentes em altura como por exemplo; calhas electricas ou candeiros.

SUBSTITUIÇÃO E MONTAGEM DE PEÇAS

- ⚠ A montagem, assistência e afinações ou manutenção de rotina desta maquina, deverão ser somente executadas por tecnicos ou pessoas devidamente qualificadas para o efeito.
- ⚠ Não faça qualquer tipo de alteração prévia nesta maquina sem aprovação prévia. Se tal acontecer poderá provocar danos e perigos imprevisíveis.
- ⚠ A substituição ou reparação de peças deverá ser feita apenas com peças de origem ou especificadas pela "Namco Europa Ltd." (incluindo parafusos)
- ⚠ Certifique-se que a maquina se encontra desligada sempre que iniciar qualquer tipo de trabalho de manutenção. (identificação de avarias, reparação etc.)
- ⚠ Caso esteja a efectuar um trabalho não descrito neste manual, certifique-se que contacta o seu distribuidor para obter instruções, caso contrário não serão aceites responsabilidades por danos causados ou ferimentos.
- ⚠ Algumas zonas da fonte de alimentação e do monitor ficam quentes e transportam correntes de alta voltagem, mesmo depois de a maquina ter sido desligada, podendo causar queimaduras e choques electricos. Tome cuidado para não tocar acidentalmente estas zonas.
- ⚠ Certifique-se que a maquina está desligada antes de ligar ou desligar qualquer tipo de fichas ou junções.
- ⚠ Quando desligar a ficha principal da maquina ou a ficha do cabo de alimentação das tomadas da parede, deverá sempre agarrar na ficha e nunca puxar pelo cabo da mesma.



Ingen del av denna publikation får reproduceras, varken fotografiskt, elektroniskt eller i någon form av ljudinspelning. Det får inte heller lagras i något återvinningssystem, översändas eller på annat sätt kopieras för offentlig eller privat användning, utan tillstånd från NAMCO EUROPE LIMITED.

Eftersom informationen i denna manual lämnas ut i god tro och var korrekt när den trycktes, reserverar sig NAMCO EUROPE LIMITED för ändringar.

Denna maskin har tillverkats enligt direktiv från europeiska unionen, är testad och uppfyller direktiven enligt 89/336EEC och 72/23/EEC med tillämpning av EN55014-1, EN55014-2 och EN60334-2-82 standard (se manualens framsida) och bär därmed också CE-märket. Varje förändring eller modifiering av denna maskin måste ske i överens-stämmelse med EU-direktiven.

En förändring i denna produkt, som inte är auktoriserad, kan strida mot dessa direktiv.

Under vissa omständigheter när det gäller extrema externa störningar, t ex radiosändningar, elektrostatiska urladdningar eller nätburna strömstörningar, kan resultera i en något nedsatt funktion. Maskinen kommer dock att återgå till normal funktion, så snart störningen har upphört eller avlägsnats.

OBS! Om spelprocessorn startar om till följd av ett avbrott eller reducering av strömmen kan registrerade krediter gå förlorade.

Detta spel är inte en maskin enligt definitionen i Maskindirektivet 89/392/EEC

SÄKERHETS VARNING

För att maskinen ska kunna användas på ett säkert sätt, ska manualen läsas noggrant före installation, användning eller justering.

Om ägaren till maskinen anförtror någon annan person att montera isär, installera, justera maskinen eller utföra rutinunderhåll, ska ägaren försäkra sig om att denna person läser om försiktighetsåtgärder och tillämpliga delar av denna manual innan arbetet påbörjas.

För att förhindra att någon olycka händer när maskinen är igång, måste säkerhetspunkterna beskrivna nedan följas strikt.

Denna manual tillsammans med installationsmanualen (när tillämpligt) utgör en integrerad del av utrustningen och måste vara ständigt tillgänglig för operatörer och service personal.

Maskinen är avsedd för inomhusbruk och ska endast användas för detta ändamål.

Namco Ltd. bär inget ansvar för olyckor eller skador som orsakats av icke auktoriserade ändringar i maskinen eller felaktigt användande av densamma.

SÄKERHETSANVISNINGAR

Säkerhetsanvisningarna nedan används genomgående i manualen. Gör dig förtrogen med varje anvisning och dess innebörd innan installation, service eller justeringar görs på denna maskin.

VARNING ⚠ "Varning" anger en fara som skulle kunna skada eller förorsaka dödsfall. Fortsätt inte vid en sådan varningsanvisning innan de påvisade förhållandena är förstådda och åtgärdade i sin helhet.

OBSERVERA ⓘ "OBSERVERA" anger en fara som skulle kunna förorsaka skada på maskinen. Fortsätt inte vid en sådan varningsanvisning innan de påvisade förhållandena är förstådda och åtgärdade i sin helhet.

ALLMÄNNA SÄKERHETSBEAKTANDEN

- ⚠ **Sätt inte igång maskinen utan att ha kontrollerat att den är korrekt installerad och i överensstämmelse med manualen.**
- ⚠ **Varningsanvisningarna måste alltid hållas i gott skick och ersättas när de blir slitna, så att kunderna kan läsa dem tydligt.**
- ⚠ **Om det uppstår fel eller problem med maskinen, måste användningen stoppas omedelbart och problemet rättas till innan den åter används.**
- ⚠ **Installation, service, justeringar eller rutinunderhåll ska endast utföras av en för ändamålet kvalificerad person.**
- ⚠ **För kontinuerligt skydd mot brandfara, ska man försäkra sig om att huvudsäkringarna endast ersätts med samma typ och specifikationer. Användandet av andra säkringar eller material är förbjuden.**
- ⚠ **Strömförsörjningen inne i monitorn håller sig varm och har områden med hög spänning, även när maskinen stängts av och det finns risk för brännskada eller elektriska stötar. Var försiktig och vidrör aldrig sådana områden.**
- ⚠ **För att förhindra en eventuell elektrisk stöt förorsakad av fel, MÅSTE maskinen vara försedd med säkert ansluten JORDAD kontakt.**
- ⚠ **Om strömförsörjningskabeln på något sätt skadas, måste den bytas ut omedelbart.**
- ⚠ **Vrid inte strömbrytaren till ON innan maskinen är korrekt installerad.**
- ⓘ **Innan strömmen sätts på till maskinen, måste man försäkra sig om att den är inställd på rätt spänning och att rätt säkringar är isatta.**

ATT BEAKTA VID INSTALLATION

- ⚠ Sätt aldrig på strömmen på maskinen innan installationen är klar.
- ⚠ För att förhindra elektriska chocker, försäkra dig om att maskinen kopplas till strömförsörjning med jordad kontakt
- ⚠ För att undvika skador av spelets rörelser, försäkra dig om att det finns ett avstånd på minst 500 mm till annan maskin eller vägg.
- ⓘ För att undvika skador på maskinen p g a felaktigt handhavande, försäkra dig om att strömstyrkan är 230 volt AC.

OBSERVERA: Om maskinen är placerad på ett polerat golv, rekommenderas att placera gummbrickor under nivåjusteringen för att förhindra att maskinen glider på golvet.

OBSERVERA: För att kunna komma åt strömförsörjningen och CPU, se till att baksidan av huvudkabinettet är placerat minst 500 mm från vägg eller annan maskin.

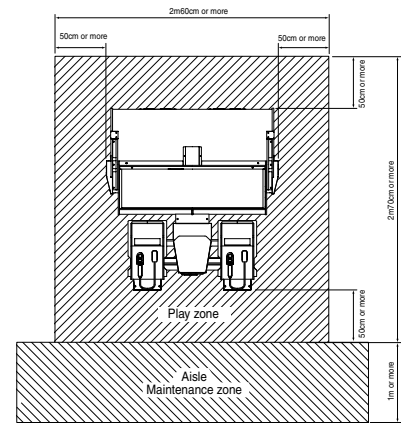

- ⚠ Spelet är försett med hjul för att underlätta förflyttningar. Var försiktig om spelet ska flyttas på en sluttande yta.
- ⚠ Toppskylten har tyngdpunkten framtill, därför är det viktigt att minst 2 personer sätter dit eller tar bort den.
- ⚠ Toppskyltens placering är mycket högt upp och det är viktigt att sådana hjälpmedel används så att man når upp utan att sträcka sig (t ex trappstege, pall osv).
- ⚠ Den totala höjden är 2220 mm, tänk på eventuella högt placerade hinder, t ex lampor.

ATT TA BORT ELLER BYTA UT ENHETER OCH DELAR

- ⚠ Justeringar och underhåll på denna maskin skall endast utföras av kvalificerad personal.
- ⚠ Gör inga ändringar på denna maskin utan ett godkännande i förväg. Detta kan förorsaka oförutsägbar fara.
- ⚠ Endast delar som är specificerade av Namco Europe Ltd. ska användas vid utbyten eller reparation av delar (inklusive skruvar).
- ⚠ Försäkra dig om att strömmen är avstängd innan underhållsarbete påbörjas (felsökning, reparationer etc.)
- ⚠ Om arbete ska utföras som inte är beskrivet i denna manual, är det viktigt att kontakta återförsäljaren för instruktioner eftersom inget ansvar accepteras för åverkan eller personskador.
- ⚠ Delar av strömförsörjningen och monitorn är varma och strömbärande även efter strömmen stängts av och kan orsaka brännskador eller elektriska stötar.
- ⚠ Försäkra dig om att maskinen är avstängd innan kontakter sätts i eller tas ur.
- ⚠ När kontakten tas ur maskinen eller ur väggen, ta alltid tag i kontakten och inte i sladden.



Tästä julkaisusta ei saa ottaa missään muodossa kopioita yksityis- tai julkiseen käyttöön ilman **NAMCO EUROPE LIMITED**:in lupaa.

Tässä ohjekirjassa olevat tiedot pitävät julkaisuhetkellä paikkansa. NAMCO EUROPE LIMITED:illä on kuitenkin oikeus muutoksiin ilman erillistä ilmoitusta.

Tämä laite on valmistettu EC direktiivien mukaisesti. Se on testattu ja todettu noudattavan seuraavia direktiivejä: 89/336/EEC ja 72/23/EEC (EN55014-1, EN55014-2 ja EN 60334-2-82 standardit). Näin ollen tämä laite on varustettu CE-merkinnällä. Kaikki tähän laitteeseen kohdistetut muutokset on tehtävä EC- direktiivien mukaisesti. Mikä tahansa valtuuttamattoman huoltomiehen tekemä muutos voi olla direktiivien vastainen.

Laitteen toiminta voi häiriintyä määrättyissä olosuhteissa, jotka johtuvat äärimmäisistä ulkoisista sähköhäiriöistä, kuten radiolähetys, elektrostaattinen purkaus tai vahvavirrasta syntynyt häiriö. Toiminta normalisoituu kuitenkin heti, kun ulkoinen sähköhäiriö on poistettu.

Huom:- Jos peliprosessori resetoituu sähkökatkoksen tai vastaavan johdosta, voivat kaikki pelivaraukset hävitä.

Tämä laite ei ole 89/392/EEC direktiivien mukainen kone.

Turvallisuusvaroitukset

Tämän laitteen turvallinen käyttö edellyttää käyttöohjekirjan huolellista lukemista ennen laitteen asennusta, säätöä tai käyttöä.

Jos tämän laitteen omistaja antaa jollekin toiselle osapuolelle tehtäväksi purkaa, asentaa, säätää tai muuten huoltaa laitetta, on omistajan varmistuttava siitä, että toinen osapuoli on lukenut ja ymmärtänyt käyttöohjekirjan oleelliset osat ennen työhön ryhtymistä.

Turvallisuusohjeita on seurattava tarkoin vahinkojen välttämiseksi laitteen ollessa käytössä .

Tämä ohje sekä mahdollinen asennusohje muodostavat laitteiston oleellisen osan ja on siksi aina oltava huolto- ja käyttöhenkilökunnan käytettävissä.

Tämä laite on tarkoitettu vain sisätilakäyttöön. Sitä ei saa käyttää muihin tarkoituksiin.

Namco Ltd ei vastaa niistä onnettomuuksista, loukaantumisista tai vahingoista, jotka johtuvat laitteeseen ilman Namco Ltd:n lupaa tehdyistä muutoksista laitteen väärästä käytöstä.

Turvallisuusohjeet

Tässä käyttöohjekirjassa on käytetty seuraavia turvallisuuteen liittyviä huomautuksia. Tutustu jokaiseen näistä. Älä asenna, huolla tai säädä laitteistoa, ennen kuin olet täysin ymmärtänyt mitä ne tarkoittavat.

VAARA ⚠️ "Vaara" tarkoittaa uhkaa, joka voi johtaa loukkantumiseen tai kuolemaan, **Älä koskaan ohita Vaara-merkintää, ennenkuin ohjeissa esitetyt olosuhteet on ymmärretty täysin.**

VAROITUS ⓘ "Varoitus" tarkoittaa uhkaa, joka voi johtaa laitteen vioittumiseen. Älä koskaan ohita Vaara-merkintää, ennenkuin ohjeissa esitetyt olosuhteet on ymmärretty täysin.

YLEISET TURVALLISUUNÄKÖKODAT

- ⚠️ Varmista, että laite on asennettu oikein ja ohjekirjan mukaisesti ennen käyttöönottoa.
- ⚠️ Varoituslaulut on pidettävä hyvässä kunnossa. Jos ne ovat kuluneet, ne on ehdottomasti vaihdettava, jotta asiakkaalla olisi mahdollisuus lukea niitä selvästi.
- ⚠️ Jos laitteeseen tulee vika tai ongelmia, on se pysäytettävä välittömästi ja ongelma selvitettävä ennen uutta käyttöönottoa.
- ⚠️ Vain riittävän ammattipätevyyden omaava henkilö saa suorittaa asennus-, huolto-, säätö- tai muita laitteeseen kohdistuvia rutiinitoimenpiteitä.
- ⚠️ Jotta palovaaraa ei syntyisi, saa pääsulakkeita vaihtaa vain samankokoisiin sulakkeisiin. Muiden sulakkeiden tai materiaalin käyttö on ehdottomasti kielletty.
- ⚠️ Monitorin sisällä oleva virtalähde pysyy kuumana ja siinä on alueita, joissa on korkeajännite vaikka laite on kytketty pois päältä. Palovammojen tai sähköiskun saaminen on mahdollista. Älä koske näihin alueisiin.
- ⚠️ Sähköiskujen välttämiseksi vikatapauksissa, laite on ehdottomasti kytkettävä maadoitetulla johdolla maadoitettuun pistorasiaan.
- ⚠️ Vioittunut verkkojohto on välittömästi vaihdettava.
- ⚠️ Älä kytke laitetta päälle, ennen kuin se on oikein asennettu.
- ⓘ Varmista ennen verkkoon kytkemistä, että virtalähteen jännitteen asetus on asetettu oikealle jännitteelle ja että siinä on oikeat sulakkeet.

ASENNUSHUOMIOITA

- ⚠ **Älä koskaan kytke laitetta päälle ennen kuin asennus on suoritettu loppuun.**
- ⚠ **Tämän laitteen virtalähde on kytkettävä maadoitetulla johdolla maadoitettuun pistorasiaan, jotta sähköiskun vaaraa ei olisi.**
- ⚠ **Varmista, että laitteen ja seinän tai toisen laitteen välissä on vähintään 500 mm, jotta asiakkaat eivät loukkaannu laitteen liikkumisesta johtuen.**
- ⓘ **Varmista, että virtalähteen jännite on 230 V AC, jotta ei laite vioitu.**

Huomio: Jos tämä laite sijoitetaan liukkaalle esim. vahatulle lattialle, suositellaan laitettavaksi kumityynyt säätöjalkoihin liikkumisen estämiseksi.

Huomio: Varmista, että takaosan taakse jää vähintään 500 mm tilaa, jotta virtalähteeseen ja CPU-korttiin pääsee käsiksi.

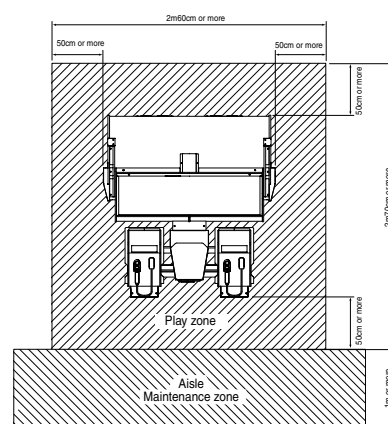

- ⚠ **Laite on varustettu kääntyvillä pyörillä. Tämä on pidettävä mielessä, kun laitetta siirretään kaltevalla alustalla.**
- ⚠ **Yläosan painopiste on yläosan etuosassa. Tästä syystä on yläosaa asennettaessa tai poistettaessa oltava vähintään kaksi henkilöä.**
- ⚠ **Yläosan asennusasento on erittäin korkealla. On tärkeää, että tarvittavalle korkeudelle päästään vaivattomasti ilman venyttämistä. (esim. käytä tukevia tuoleja tai tikkaita)**
- ⚠ **Laitteen kokonaiskorkeus on yli 2220 mm. Varmista, ettei katossa ole esteitä. esim. valaisimia.**

- ⚠ **Vain riittävän ammattipätevyyden omaava henkilö saa suorittaa asennus-, huolto-, säätö- tai muita laitteeseen kohdistuvia rutiinitoimenpiteitä.**
- ⚠ **Tälle laitteelle ei saa tehdä mitään hyväksymättömiä muutoksia. Se voi aiheuttaa ennalta-arvaamattomia vaaroja.**
- ⚠ **Vain Namco Europe Ltd:n määrittelemiä varaosia saa käyttää vaihtaessasi tai korjatessasi osia. (sisältäen ruuvit).**
- ⚠ **Varmista, että laite on kytketty POIS PÄÄLTÄ ennen työn aloittamista.**
- ⚠ **Ota yhteyttä maahantuojaan ohjeita varten, jos joudut tekemään työtehtäviä, joita ei ole esitelty huoltokirjassa, muuten vastuuta vioista tai loukkaantumisista ei ole.**
- ⚠ **Virtalähde ja monitori pysyvät kuumina ja niissä on alueita, joissa on korkeajännite vaikka laite on kytketty pois päältä. Palovammojen tai sähköiskun saaminen on mahdollista. Älä koske näihin laitteisiin.**
- ⚠ **Varmista, että laite on kytketty POIS PÄÄLTÄ ennen johtojen kytkemistä tai irrottamista.**
- ⚠ **Irrottaessasi verkkojohdon seinästä tai laitteesta, ota kiinni itse pistokkeesta, ei johdosta.**

1. SPECIFICATIONS

POWER SUPPLY:-	230vAC (50/60Hz)
MAX. POWER CONSUMPTION:	580watts
AMBIENT OPERATING TEMPERATURE	+5°C to +25°C
MONITOR:-	Pantronic 29" Flat Screen w/o Remote
COIN ACCEPTOR:-	Mars CashFlow - 4 Channel Dispense

DIMENSIONS:-	
Assembled	1570(w) x 1660(d) x 2200(h)
Monitor Cabinet	1570(w) x 790(d) x 1890(h)
Gun/Coin Assembly	1200(w) x 540(d) x 1120(h)
Header Assembly	1330(w) x 390(d) x 340(h)
Jointbox	500(w) x 290(d) x 230(h)
Pedal Assembly (x2)	250(w) x 250(d) x 160(h)



WEIGHT:-	
Assembled	383kg
Monitor Cabinet	297kg
Gun/Coin Assembly	70kg
Header Assembly	20kg
Jointbox	6kg
Pedal Assy (x2)	6kg ea

ACCESSORIES:-	Keys: (Cash Door) 2
	(Coin Door) 2
	(Back Door) 2
	IEC Mains Lead 1
	Link Cable 1
	Operators Manual 1
	Monitor Manual 1
	CashFlow Documents 1
	M5 Security Wrench 1

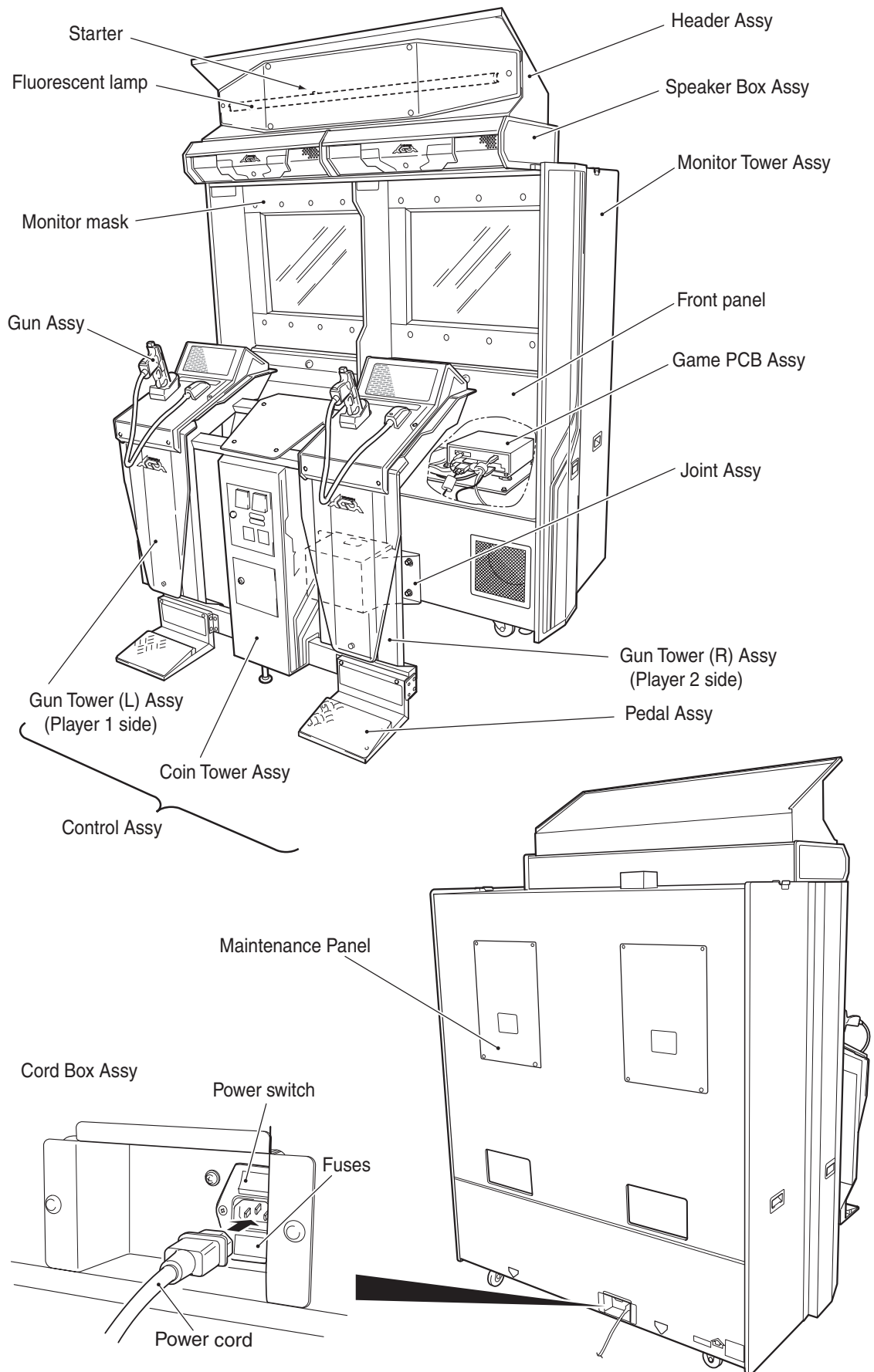
2. MAIN COMPONENTS







3. MOVING THE MACHINE

-  This equipment is fitted with castors to make it easier to move. Take care when moving the equipment on an inclined floor.
-  The overall height of this equipment is 2220mm. Take care of any overhead obstructions. (e.g. Light Fittings, Electric Cables etc.)
-  Before moving, ensure that the game is separated into 3 parts: Header Assy, Monitor Cabinets and Gun/Coin Assy.

4. INSTALLATION

Notes on Installation

-  **NEVER** turn the power to the machine ON until installation has been completed
-  In order to prevent possible electric shocks, be sure that the machine is connected to the mains supply with a securely connected earthed plug.
-  So that customers are not injured, ensure that there is at least 500mm separation between other machines or walls.
-  In order to avoid damage to the machine due to mis-operation, ensure that the voltage of the mains supply is 230volts AC.

- NOTE
- If the location site of this machine has a polished floor, it is recommended that rubber pads are fitted under the level adjusters to prevent the machine sliding on the floor.
 - In order to gain access to the Power Supply and CPU assemblies, ensure that the rear of the machine is separated from a wall or other machine by at least 500mm

Preventing Cross Talk

If machines using the same gun detecting system are installed side by side, cross talk may occur between them resulting in machine malfunction. If machines of the same type are to be installed side by side, make sure that they are alternately 'Frequency Change connector' installed Game PCB and 'Frequency Change connector' not installed Game PCB models. The 'Frequency Change Connector' is fitted to the Player 2 Game PCB.



This machine is designed for **INDOOR USE ONLY**.
Do not install in the following places.

1. Outdoors
2. Direct Sunlight, places with excessive humidity or dust, places where there is water leakage, near air-conditioning or heating equipment, places with excessive heat or cold temperature.
3. Places where it would be in the way of emergency exits or fire extinguishing equipment.
4. Unstable places or places with excessive vibration.
5. Places that are not level.
6. This machine **must not** be cleaned with a water jet, or installed in an area where a water jet could be used.



DIESES GERÄT IST NUR FÜR DIE GEWERBLICHE AUFSTELLUNG IN GESCHLOSSENEN RÄUMEN BESTIMMT. DAS GERÄT DARF AN FOLGENDEN PLÄTZEN NICHT AUFGESTELLT WERDEN

1. Im Freien.
2. In direktem Sonnenschein, an extrem feuchten und staubigen Plätzen, an Plätzen mit Wasseranschlüssen und möglichen Leckagen, nahe Klima- und Heizungsanlagen, an Plätzen mit extrem hohen oder niedrigen Temperaturen.
3. In der Nähe von Notausgängen oder Feuerlöschgeräten.
4. An unstabilen Plätzen oder Plätzen mit übermäßiger Vibration.
5. An Plätzen, die nicht eben sind.
6. Diese Maschine darf nicht mit einem Wasserstrahl gereinigt oder in einem Bereich installiert werden, in dem Wasserstrahlen verwendet werden.



**DENNE MASKINE ER KUN DESIGNET TIL INDENDØRSBRUG
INSTALLER IKKE MASKINEN PÅ FØLGENDE STEDER**

1. Udendørs
2. Direkte sollys, steder med høj fugtighed el. støv, steder med vand udslip, i nærheden af air-condition eller varme udstyr, steder med usædvanlig høj el. kold temperatur.
3. Steder hvor den vil stå i vejen for nødudgange eller brandslukningsudstyr.
4. Ustabile steder eller steder med for store vibrationer.
5. Steder der ikke er plane.
6. Maskinen må ikke renses med en vandstråle eller monteres et sted hvor det er muligt at bruge en vandstråle.



ESTA MÁQUINA ESTA DISEÑADA ÚNICAMENTE PARA USO EN INTERIORES. NO INSTALE LA MÁQUINA EN LOS SIGUIENTES LUGARES.

1. Exteriores.
2. Bajo luz solar directa, en lugares con polvo o humedad excesiva, lugares donde hay filtraciones de agua, cerca de aparatos de calefacción o de aire acondicionado, lugares con temperatura ambiente muy alta o muy baja.
3. Lugares donde la máquina obstruya salidas de emergencia o equipos de extinción de incendios.
4. Suelos inestables o lugares con vibraciones excesivas.
5. Lugares con suelos no nivelados.
6. Esta máquina no deberá ser lavada con agua a presión. Tampoco deberá instalarse en áreas donde puedan haber chorros de agua.

F

**CETTE MACHINE EST DESTINEE UNIQUEMENT A UN USAGE INTERIEUR
NE PAS INSTALLER LA MACHINE DANS LES ENDROITS SUIVANTS**

1. A l'extérieur.
2. Directement exposée au soleil, aux endroits excessivement humides ou poussiéreux, aux endroits où il y a des risques de fuite d'eau, près de ventilateurs ou source de chaleur, aux endroits très chauds ou froids.
3. Dans des zones de proximité des sorties de secours ou d'accès aux équipements d'extinction du feu.
4. Dans des emplacements instables ou soumis à de fortes vibrations.
5. Dans des endroits dénivelés.
6. Ne nettoyez pas cette machine sous un jet d'eau et ne l'installez pas à un endroit où l'on risque d'employer des jets d'eau.

GR

**ΤΟ ΜΗΧΑΝΗΜΑ ΕΙΝΑΙ ΣΧΕΔΙΑΣΜΕΝΟ ΓΙΑ ΧΡΗΣΗ ΣΕ ΕΣΩΤΕΡΙΚΟ ΧΩΡΟ ΜΟΝΟ
ΜΗΝ ΤΟΠΟΘΕΤΗΣΕΤΕ ΤΟ ΜΗΧΑΝΗΜΑ ΣΤΟΥΣ ΑΚΟΛΟΥΘΟΥΣ ΧΩΡΟΥΣ**

1. Εξωτερικά
2. Απευθείας στον ήλιο, σε μέρη όπου υπάρχει υγρασία ή σκόνη, μέρη όπου υπάρχει άφθονο νερό, κοντά σε air-condition ή άλλου είδους θέρμανση, μέρη με υπερβολική υψηλή ή χαμηλή θερμοκρασία.
3. Σε μέρη όπου εμποδίζουν μέσα ανάγκης π.χ. πυροσβεστήρες ή άλλα.
4. Μη σταθερά μέρη ή μέρη με πολλούς κραδασμούς.
5. Μέρη που δεν είναι επίπεδα.

I

**QUESTA MACCHINA E' PROGETTATA PER ESSERE USATA ESCLUSIVAMENTE IN
AMBIENTI INTERNI. NON INSTALLARE LA MACCHINA NEI SEGUENTI LUOGHI.**

1. In ambienti esterni.
2. Alla luce diretta del sole, in posti con eccessiva umidità o polvere, in luoghi dove ci siano infiltrazioni d'acqua, vicino ad apparecchi di condizionamento d'aria oppure riscaldamento, in posti eccessivamente caldi o freddi.
3. In luoghi dove potrebbe esserci un'uscita di emergenza o un'attrezzatura per lo spegnimento del fuoco.
4. In posti non stabili o con eccessive vibrazioni.
5. In luoghi non piani.
6. La macchina non deve essere pulita con un getto d'acqua, né installata in un'area in cui si utilizza un getto d'acqua.

N

**DENNE MASKINEN ER BARE KONSTRUERT FOR INNENDØRS BRUK
IKKE INSTALLER MASKINEN PÅ FØLGENDE Plasser.**

1. Utendørs
2. Konstant sollys, plasser med mye fuktighet og støv, plasser hvor det er vannlekasje, nære luft kjølere eller varme elementer, plasser med overdreven høy eller lav temperatur.
3. Plasser hvor det vill stå i veien for nødutganger eller brannslukking utstyr.
4. Ustabile plasser eller plasser med overdreven vibrasjon.
5. Plasser som ikke er i vater.
6. La macchina non deve essere pulita con un getto d'acqua, né installata in un'area in cui si utilizza un getto d'acqua.

NL

**DEZE MACHINE IS ALLEEN VOOR GEBRUIK BINNENSHUIS ONTWERPEN
INSTALLEER DE MACHINE NIET OP DE VOLGENDE PLAATSEN**

1. Buiten
2. In direct zonlicht, op plaatsen met een zeer hoge vochtigheidsgraad of met veel stof, op plaatsen waar een waterlek is, dichtbij airco's of verwarmingsapparatuur, op plaatsen met een zeer hoge of koude temperatuur.
3. Op plaatsen waar nooduitgangen of blusapparatuur worden geblokkeerd.
4. Op onstabiele plaatsen of plaatsen waar grote trillingen voorkomen.
5. Op plaatsen die niet vlak zijn.
6. Deze machine mag niet gereinigd worden met een waterstraal of geïnstalleerd worden op een plaats waar een waterstraal gebruikt kan worden.

P

**ESTA MAQUINA FOI CONCEBIDA PARA UTILIZAÇÃO EM ESPACOS
INTERIORES APENAS NÃO INSTALAR A MAQUINAS NOS SEGUINTE LOCAIS:-**

1. Exteriores.
2. Luz solar directa, locais com humidade excessiva ou pó, locais aonde existam fugas de água perto de ar condicionados ou equipamentos caloríficos e locais com temperaturas excessivamente quentes ou frias.
3. Locais aonde ficaria colocada no caminho de saidas de emergência ou equipamentos extintores de fogo.
4. Locais estruturalmente instáveis ou locais com vibrações excessivas.
5. Locais não nivelados.
6. Esta máquina não deve ser limpa com jato de água, ou instalada em área na qual possam ser usados jatos de água.

S

**DENNA MASKIN ÄR AVSEDD ENBART FÖR INOMHUSBRUK
INSTALLERA EJ MASKINEN PÅ FÖLJANDE STÄLLEN**

1. Utomhus
2. I direkt solsken, platser med extremt hög luftfuktighet eller damm, platser där det förekommer vattenläckage, nära luftkonditionering eller värmeelement, i extremt hög eller låg temperatur.
3. Platser där den skulle kunna vara i vägen för nödutgångar och brandsläckningsutrustning.
4. Instabila ställen eller där stark vibration förekommer.
5. Platser med nivåskillnad.
6. Denna maskin får inte rengöras med en vatten stråle, eller monterad inom ett område där en vatten stråle kan användas.

SF

**TÄMÄ LAITE ON SUUNNITELTU VAIN SISÄKÄYTTÖÖN
ÄLÄ ASENNAA LAITETTA SEURAAVIIN PAIKKOIHIN:**

1. Ulkotilaan
2. Suoraan aurinkovaloon, kosteisiin tai pölyisiin paikkoihin, vesivuotopaikkojen läheisyyteen, ilmanvaihto- tai lämmityslaitteen lähistölle tai paikkoihin, jossa on erittäin kuumaa tai kylmää.
3. Varauoskäytävien, muiden pakoteiden tai tulensammutusvälineiden eteen.
4. Epävakaasiin tai täriseviin paikkoihin.
5. Kaltevalle alustalle.
6. Tätä laitetta ei saa pestä suihkuttamalla sille vettä eikä sijoittaa sellaiseen paikkaan, missä se voi joutua alltiiksi vesisuihkuille.

4-1 Required Dimension for Access (Doors and Passageways)

The machine is separated into the following assemblies for transportation. The size of each assembly is as follows:

Monitor Cabinet	1570(w) x 790(d) x 1890(h)	Weight	275kg
Control Assembly	1200(w) x 540(d) x 1120(h)	Weight	70kg
Header Assembly	1330(w) x 390(d) x 340(h)	Weight	20kg
Jointbox	500(w) x 290(d) x 230(h)	Weight	6kg
Pedal Assembly (x2)	250(w) x 250(d) x 160(h) (ea)	Weight	6kg (ea)

If the access route is too low for the machine's height, the Speaker Box Assy can be temporarily separated from the Monitor Cabinet to reduce the height to 1730cm.

(See 4-2 page 37)

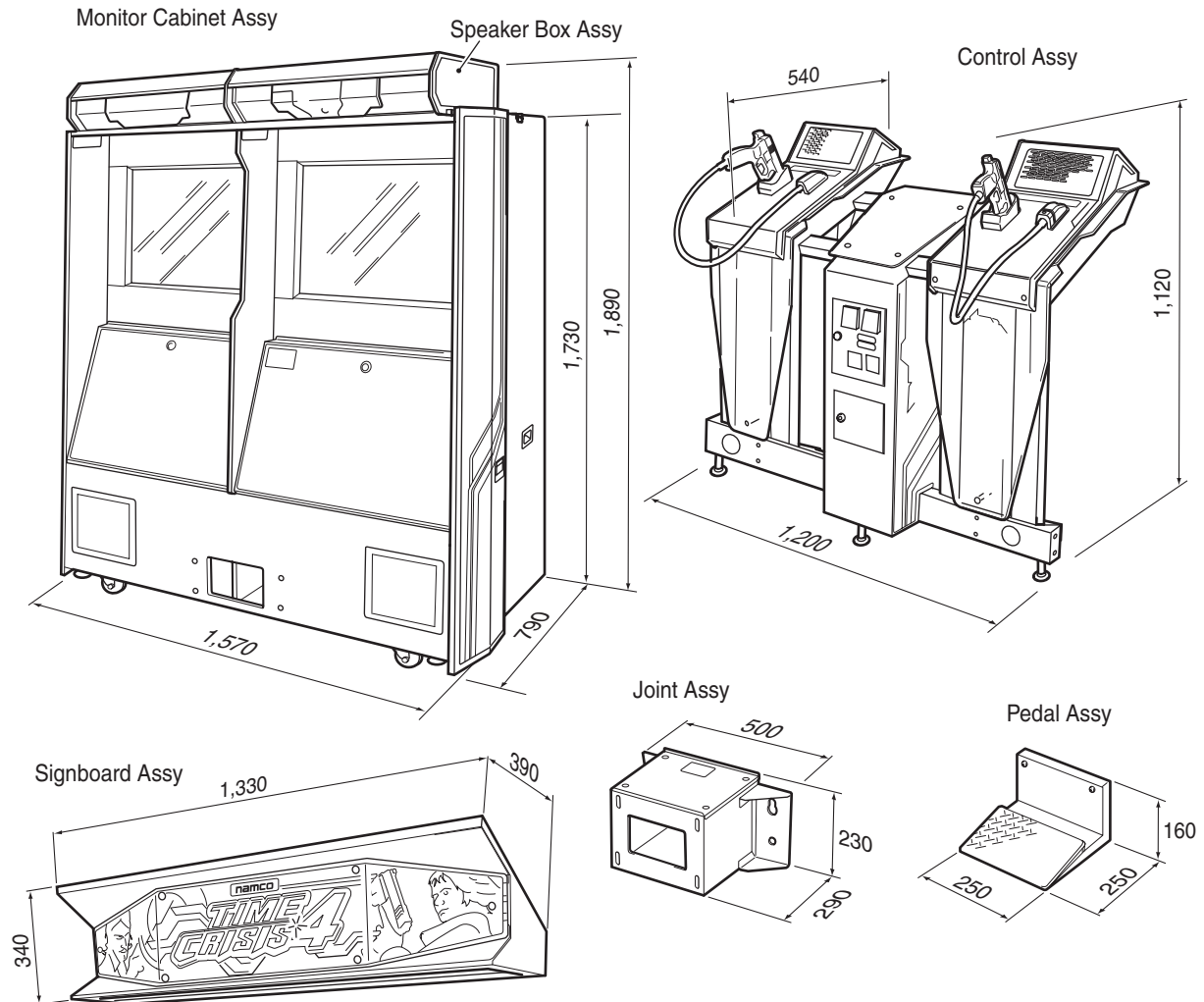

4-2 Separating the Speaker Box



The Speaker Box weighs approx 15kg. Ensure that at least two people are used to remove the Speaker Box.

The fitting position of the speaker box is very high, and it is important that a safe means of reaching the height safely, without stretching is available. (e.g. steps, step stool etc.)

1. Remove 6 off Screws (M6x20), remove the Retaining Plates, and lift the Speaker Box Assy from the Monitor Cabinet ensuring that both ends are supported by the two people.
2. Re-assemble in reverse order.

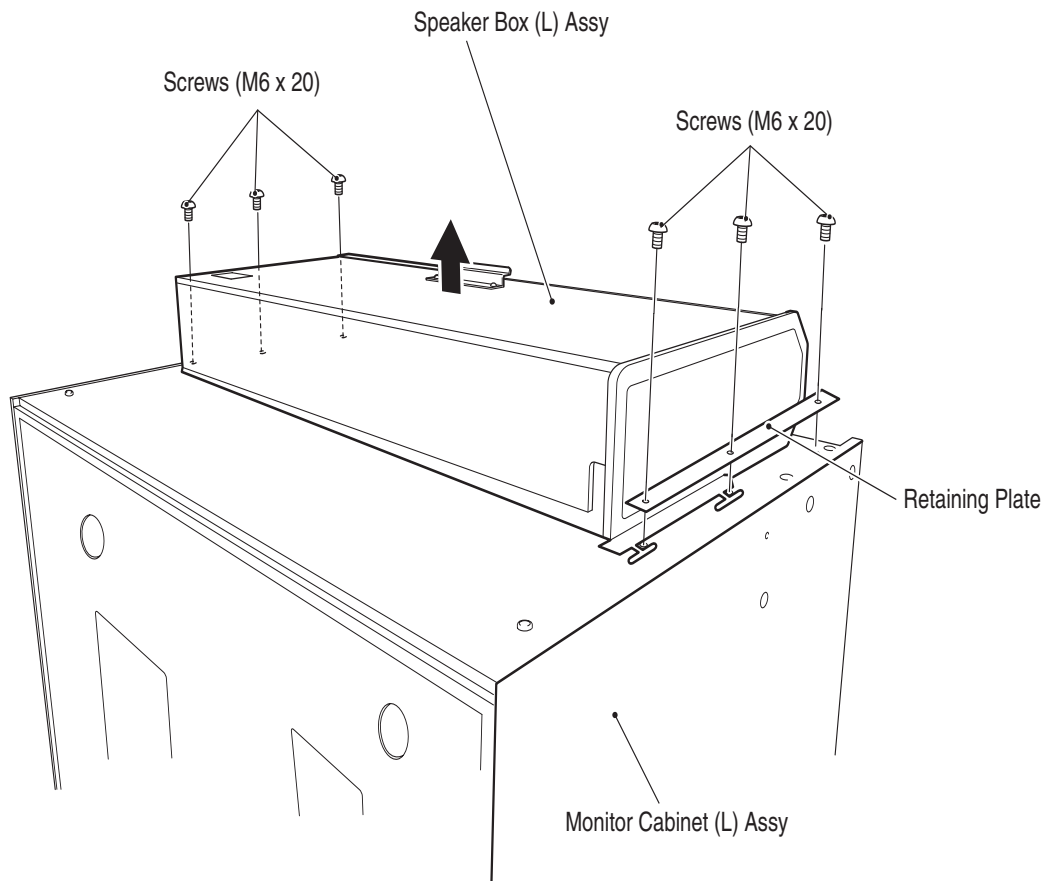

4-3 Fitting the Joint Box

1. Fit 2 off flange socket bolts (M8x40) to the upper front fixings on the front of the Projector Cabinets leaving approx 5mm protruding.

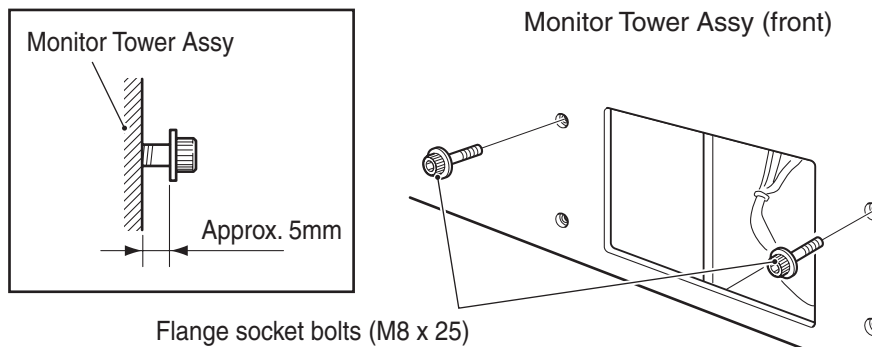

2. Remove 4 off security screws (M5x12) from the Joint Assy and remove the Joint Cover.
3. Attach the Joint Assy in place on the Monitor Cabinet and secure with the previously fitted flange socket bolts (M8x40) and two further supplied flange socket bolts (M8x40).
4. Pull out the wiring harnesses from the Monitor Cabinet.

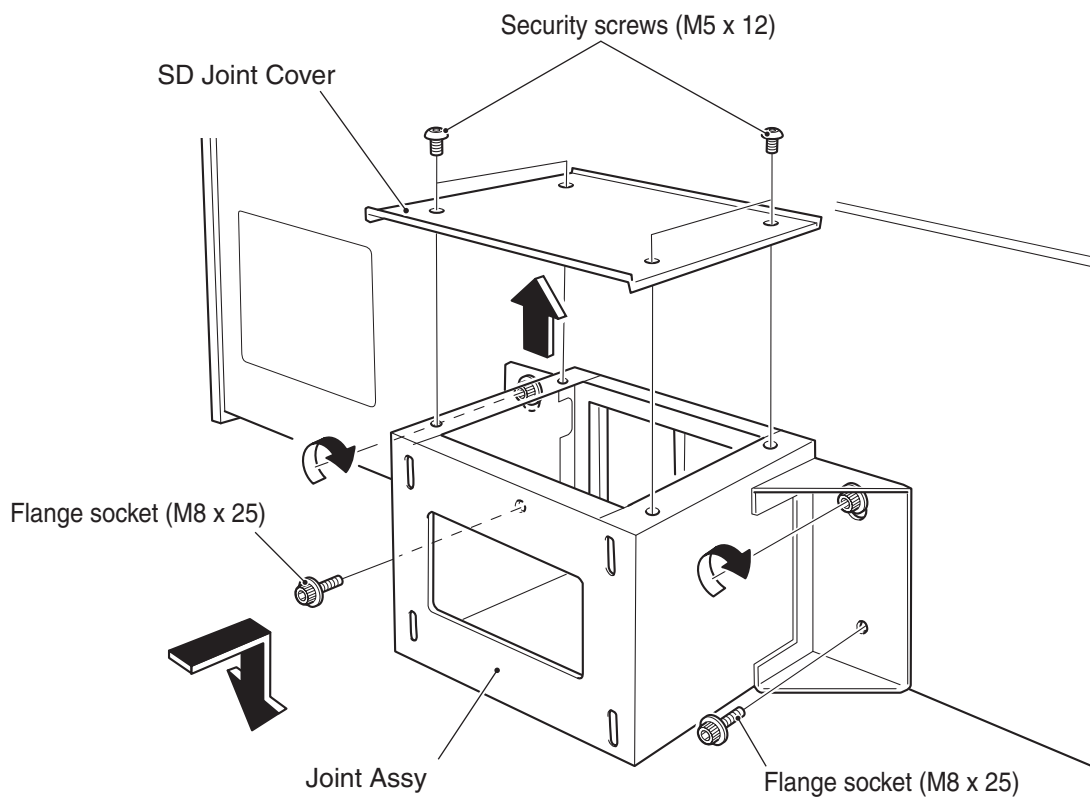

(These connectors will be connected later).

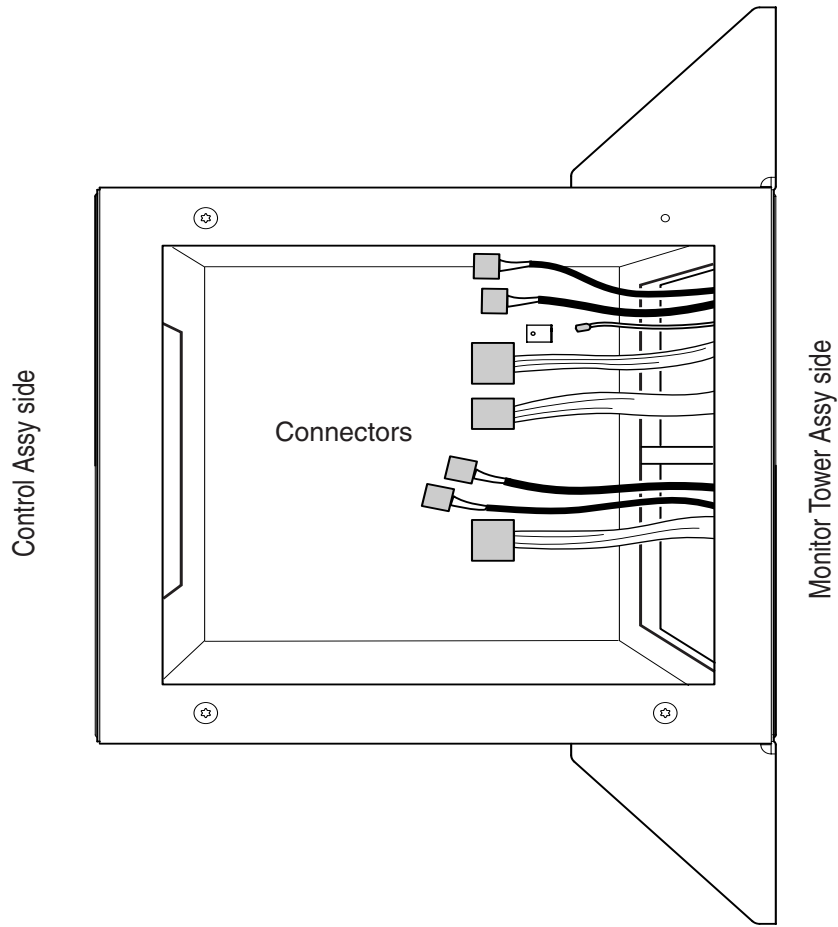

4-4 Fitting the Header Assembly



The Header Assembly weighs approx 22kg. Ensure that at least two people are used to fit the Header Assembly.

The fitting position of the Header Assembly is very high, and it is important that a safe means of reaching the height safely, without stretching is available. (e.g. steps, step stool etc.)

1. Loosen only 3 off screws (M6x20), with flat and spring washers on both sides of the Monitor Cabinet top. Slide the Speaker Box Assy to the front, and retighten the 6 off Screws (M6x20), with flat and spring washers, previously loosened.

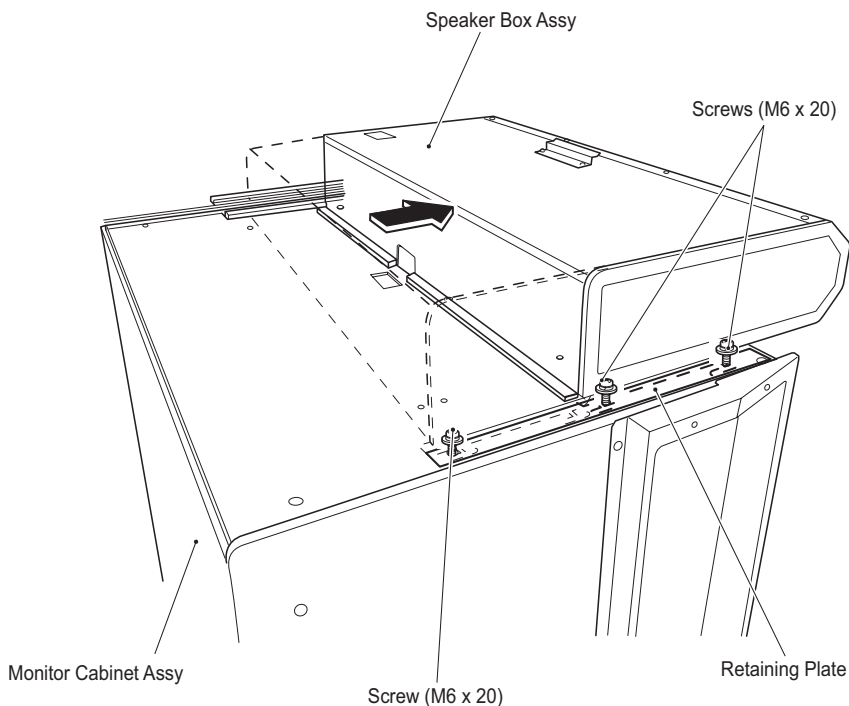

2. Withdraw the connectors from the Speaker Box Assembly and connect to the Monitor Cabinet.
3. Fit the SD Harness Cover with 2 off pozi head screws (M5x20)

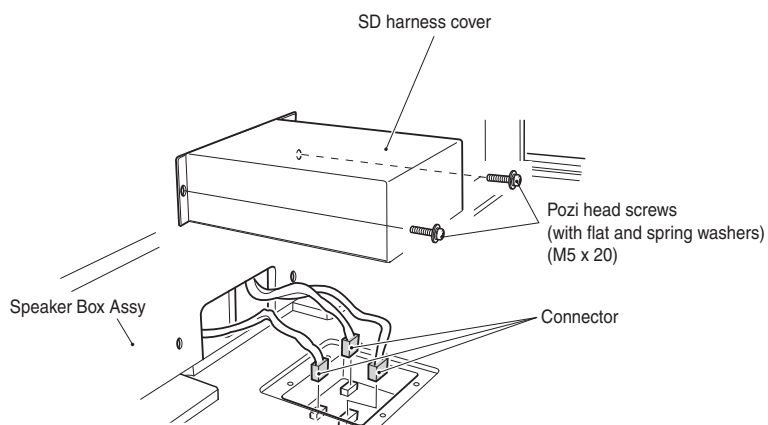

4. Place the Header Assembly onto the Speaker Box Assembly and connect the connector.
5. Slide the Header Assembly backwards ensuring that the Header Assembly is engaged under the Header Brackets.

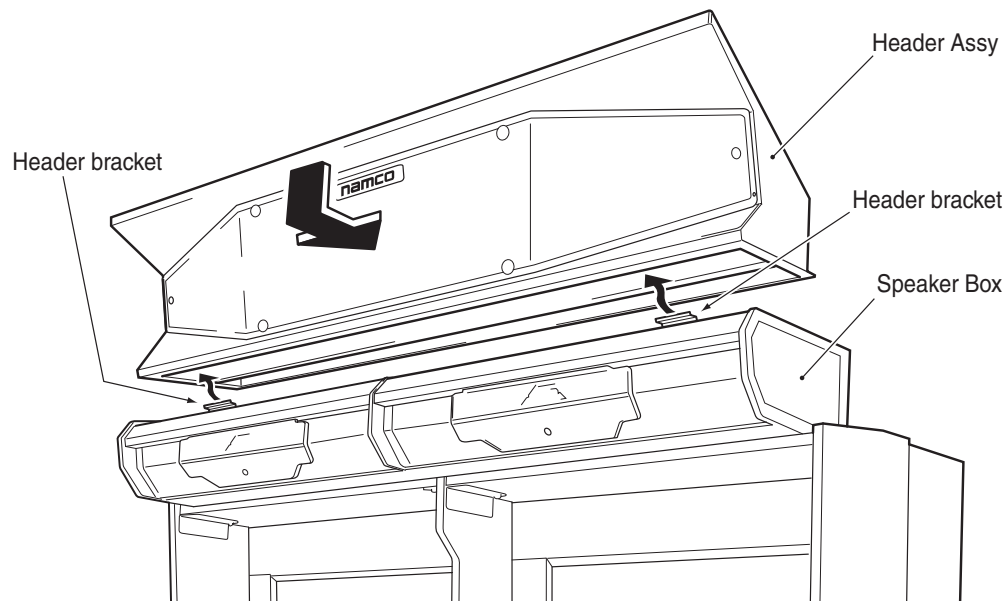

6. Secure with 2 off pozi head screws (M5x12)

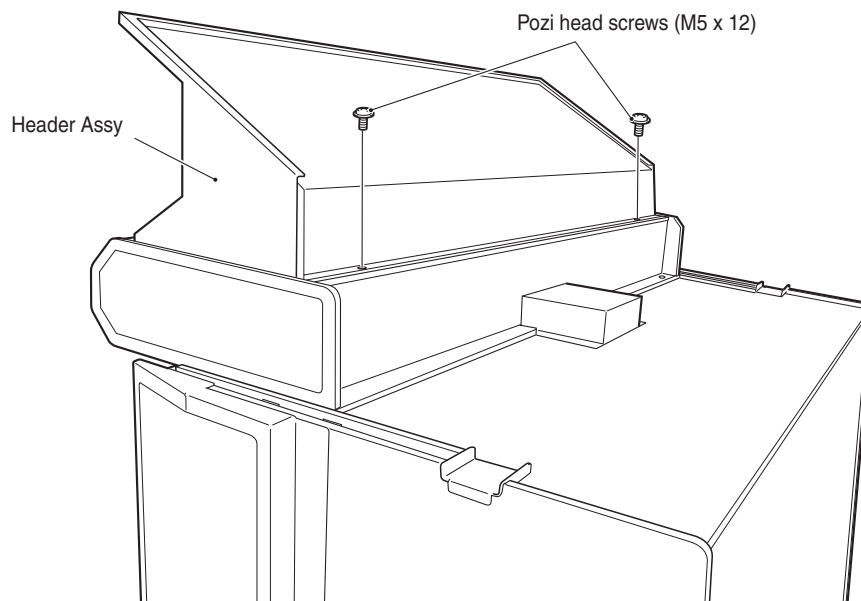

7. Disassemble in reverse order.

Note: Always remove the Header Assy and return the Speaker Box to its shipping position before moving the machine.

4-5 Fitting the Joint Assy

1. Fit 2 off flange socket bolts (M8x40) to the upper front fixings on the front of the Projector Cabinets leaving approx 5mm protruding.

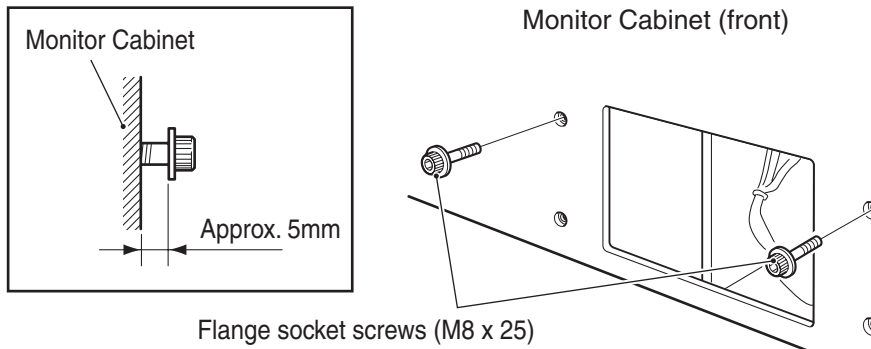

2. Remove 4 off security screws (M5x12) from the Joint Assy and remove the SD Joint Cover.
3. Attach the Joint Assy in place on the Monitor Cabinet and secure with the previously fitted flange socket bolts (M8x40) and two further supplied flange socket bolts (M8x40).

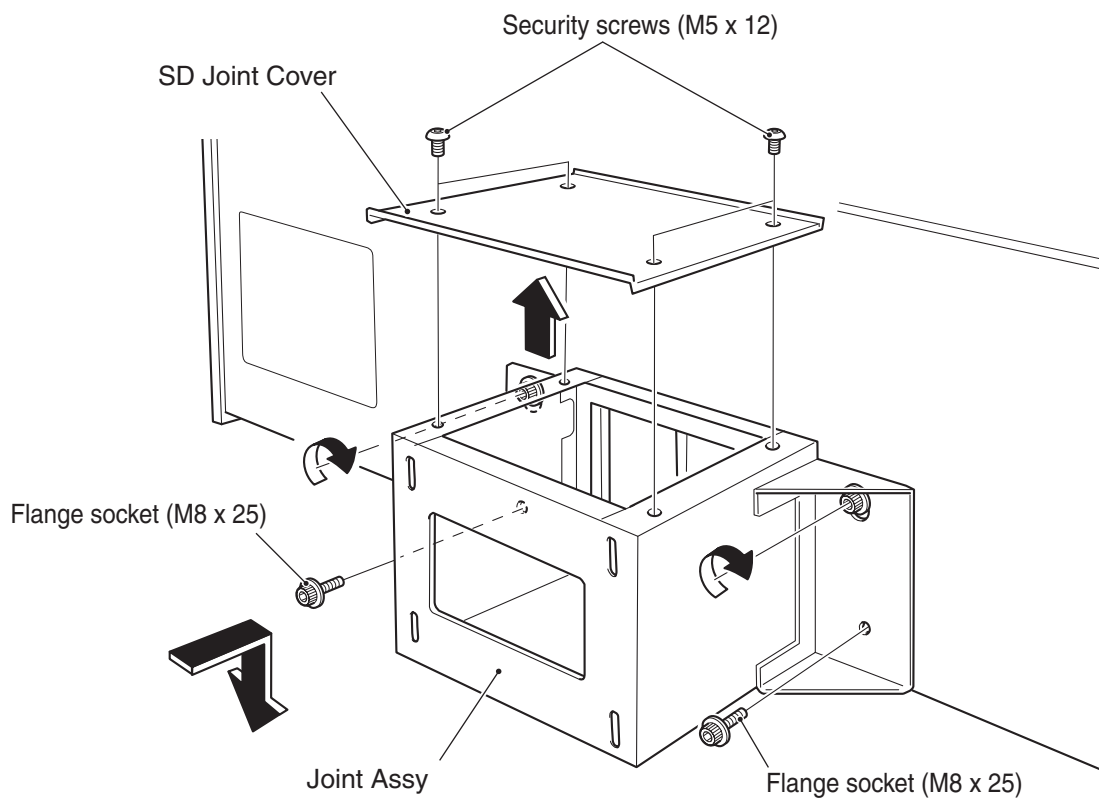

4. To disassemble follow the procedure in reverse.

4-6 Fitting the Control Assy

1. Adjust the level adjusters of the Control Assy so that it is the same height as the Joint Assy.
2. Secure the Control Assy with 4 off socket flange screws (M8x16).
3. Pull out the harnesses from both the Monitor Cabinet and Control Assy.

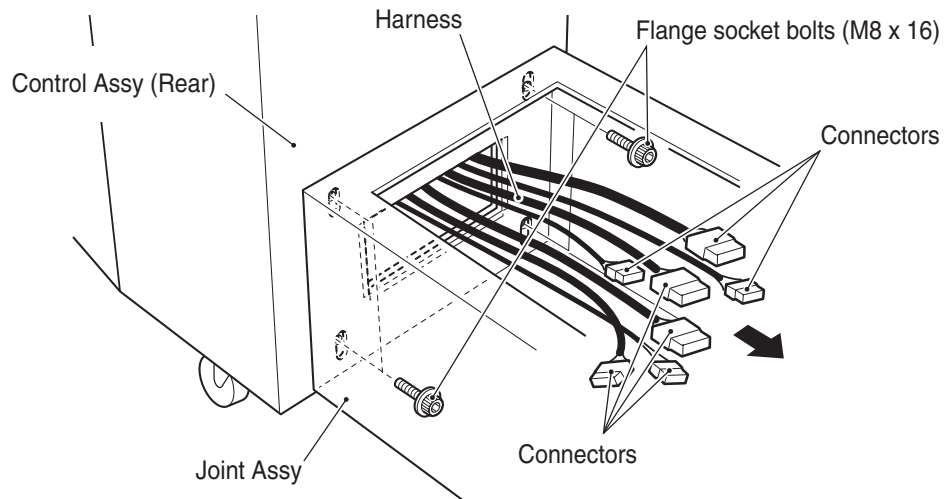

4. Connect the seven connectors and one Earth connector as shown below.

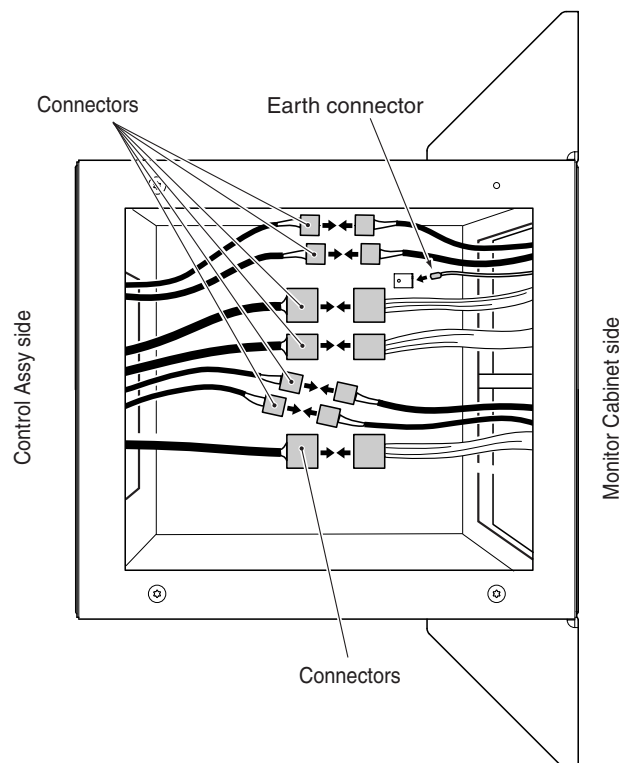

5. Refit the SD Joint Cover with 4 off security screws (M5x12).
6. To disassemble follow the procedure in reverse.

4-7 Adjusting the Level Adjusters

When the Game is in its final position, lower all level adjusters with a spanner so that the machine is level and all castors are raised from the floor by approx. 5mm. Tighten the Lock Nut with a spanner to ensure that the level adjusters do not move during game play.

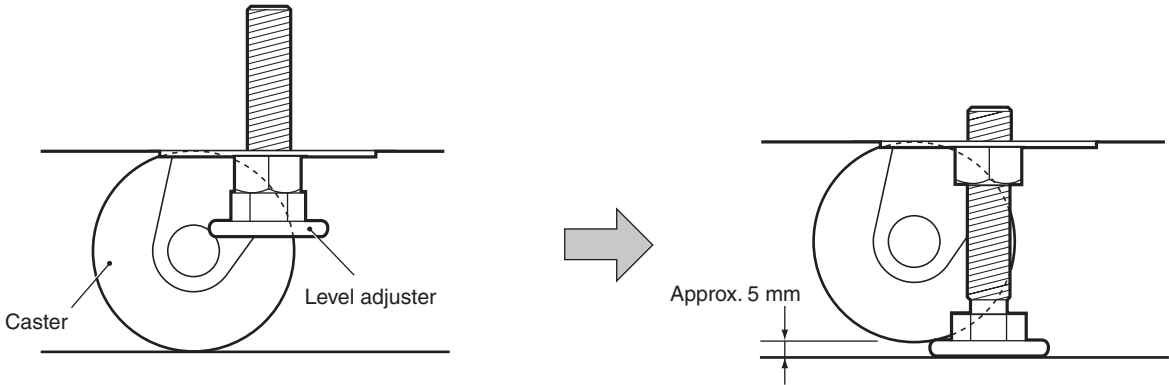

4-8 Fitting the Pedal Assy

1. Connect the Connector and fit, finger tight only, the Pedal Assy with 4 off flange socket screws (M6x12).

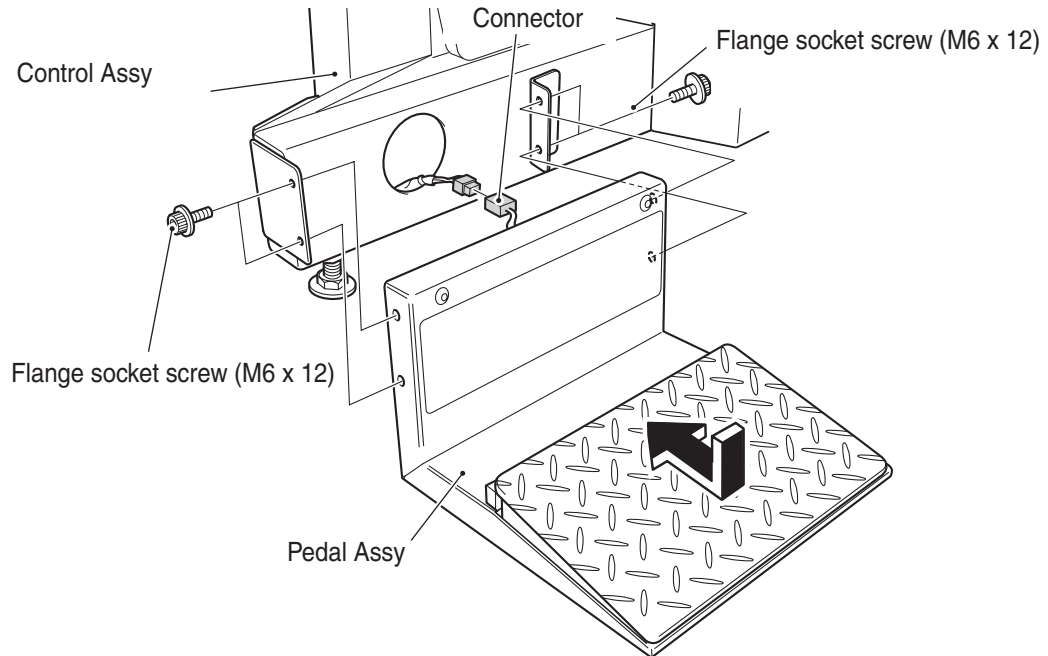

2. Push the Pedal Assy flat to the floor, and tighten fully the eight (4ea Assy) flange socket screws.
(Ensure that there is no space between the Pedal Assy and the floor.)
3. To remove, follow the installation sequence in reverse.

5. OPERATION



- ✱ Should any problem occur, immediately turn the power to the machine OFF until the problem has been rectified.
- ✱ Before operating the machine, check that the machine has been installed in accordance with the instructions and procedures specified in this manual. If the machine is not installed correctly, fire, electric shock, injury or malfunction may occur.
- ✱ Ensure that all warning labels are visible and legible at all times.
- ✱ To ensure safe operation of the machine, ensure that the pre-service and maintenance checks have been carried out. Failure to perform the pre-service maintenance checks could result in unexpected accidents.

5-1 Pre-Service Check

Check the following items before commencing operation.
If any problem is found, rectify the problem before continuing.

5-1-1 Safety Check (before power on)

1. Is any part of the Mains Cable or plug excessively warm.
2. All warning labels are attached and legible.
3. All level adjusters are adjusted properly and the machine is stable.
4. The Play Zone area is established as specified.
5. Power cable and Communication cable are routed safely and not liable to cause a person to trip over them.
6. Guns are secure and free of any damage.
7. The Joint Assy is installed securely to both the Monitor Cabinet and the Control Assy.
8. Pedal Assemblies are secure. (There must be no space between the Pedal Assy and the floor.)
9. Speaker box is installed securely to the Monitor Cabinet.
10. Header Assy is installed securely to the Speaker box .

5-1-2 Operation Check (after power On)

Turn the power to the machine ON and check the following items.

1. Does touching the machine give electric shocks.
2. Is there a smell of burning, abnormal noise or vibration.
3. Is there any other sign of abnormality or malfunction.



Note:

If any of the above occur, immediately turn the power to the machine OFF and disconnect from the power supply until the problem has been rectified.

4. Check that sound is produced from each speaker.
5. Check that the fluorescent lamp in the Header Assy is illuminated.
6. Check that the SIDELED PC boards are illuminating. (two LEDs for the Gun Tower (L) and (R) and two LEDs for the Speakerbox Assys)
7. Check that the images displayed on the Monitors are correct.

To check the following items press the Service button and play the game.

8. Check that both Guns are operating correctly.
9. Check that both Pedal Assys are operating correctly
10. Check that two players can play in linked mode.

- ✱ Do not install the machine where spot lamps, direct sunlight or other bright or flashing lights can reflect on the monitor screens as such lights may prevent the gun sensors detecting properly.

5-2 How to Play



If a player becomes unwell due to game images or stimulation by lights, have the person stop playing the game immediately and let him/her rest.

In rare cases, stimulation by lights or video images can cause a convulsion or loss of consciousness. If this happens, advise the person to see a doctor for medical examination as soon as possible. When pre-school children play, request that their parents or guardians observe the children.

(1) Operation

1. Pressing the pedal: Attack mode : The player can shoot the gun, and can be also shot by enemies.
2. Releasing the pedal: Hide mode : The player hides behind an item. Enemies' shots cannot reach the player.
Releasing the pedal also reloads the hand-gun with ordinary ammunition.

(2) Game Mode

1. Linked play mode : The mode allows two players to cooperate in a game play. In this mode, a player can join in while a game play is in process.
2. Solo play mode : This mode is played by a single player. In this mode, a player cannot join in while a game play is in process.
* The player can select the game mode on the Mode Select screen immediately after coin insertion.

(3) Game rules

1. The player loses one "life" when shot by an enemy.
When the time limit reaches zero, the player also loses one "life."
The time limit extends when the player destroys all enemies in front of the player, or receives attacks from enemies.
The game ends when the player has no "life."
2. The player's performance level is indicated by the score. The higher the score, the better the player's performance.
3. The four weapons can be selected by releasing the pedal and pressing the trigger.
Weapons have limited ammunition except for the hand-gun, and when the ammunition runs out, the player cannot use this weapon. When the specified enemy is shot, the ammunition reloading item will appear.
The demonstration scene inserted between game segments can be skipped by shooting the gun toward the screen.

(4) Event play

The player plays the game following specific event battle rules. The rules are explained in the game screen for each event. They are roughly categorized into two types of rules.

1. Multi screen battle event

The player searches and attacks the enemy while changing the screen.

When the muzzle on the screen is pointed toward the desired arrow icon on the screen, the screen will change to the desired screen. In this event, the barricade durability is indicated instead of the player's life. If the barricade durability is reduced to zero, this event will end and the player's life decreases by one.

2. Special weapon playing event

The following two weapons can be used.

When a player selects either of the two weapons, he/she cannot replace it with another weapon in the same event.

A. Special machine gun

Limitless bullets. The machine gun shoots continuously, while the trigger is pressed.

B. Sniper rifle

When the pedal is pressed, the screen zooms toward the target.

When the pedal is released, the ammunition will be reloaded.

6. ADJUSTMENTS



- Ⓒ **Adjustment or maintenance on this machine should be carried out by qualified personnel only.**
- Ⓓ **Einstellungen und Wartung des Gerätes dürfen nur von dafür qualifiziertem Fachpersonal vorgenommen werden.**
- Ⓕ **Justeringer eller vedligehold af denne maskine bør kun udføres af kvalificeret personale.**
- Ⓔ **Los ajustes y el mantenimiento de esta máquina deben ser realizados sólo por personal cualificado.**
- Ⓕ **L'installation, le service, le réglage, ou la maintenance doivent être effectués uniquement par les personnes qualifiées.**
- Ⓖ **Μετατροπές ή επιδιορθώσεις στα μηχανήματα πρέπει να γίνονται μόνο από εξουσιοδοτημένα άτομα.**
- Ⓘ **Regolazioni e manutenzione su questa macchina devono essere fatti solo da personale specializzato.**
- Ⓝ **Justering eller vedlikehold på denne maskinen skall bare utføres av kvalifiserte personell.**
- Ⓝ **Aanpassingen of onderhoud aan deze machine dient alleen uitgevoerd te worden door bekwaam personeel.**
- Ⓟ **Afinações ou manutenção nesta máquina, deverão ser efectuadas sómente por pessoal qualificado.**
- Ⓢ **Justeringar och underhåll på denna maskin skall endast utföras av kvalificerad personal.**
- Ⓢ **Tätä laitetta saa säätää tai huoltaa vain siihen ammattipätevyyden omaava henkilökunta.**

6-1 Adjustment Switches

The adjustment switches are located inside the Coin Door.

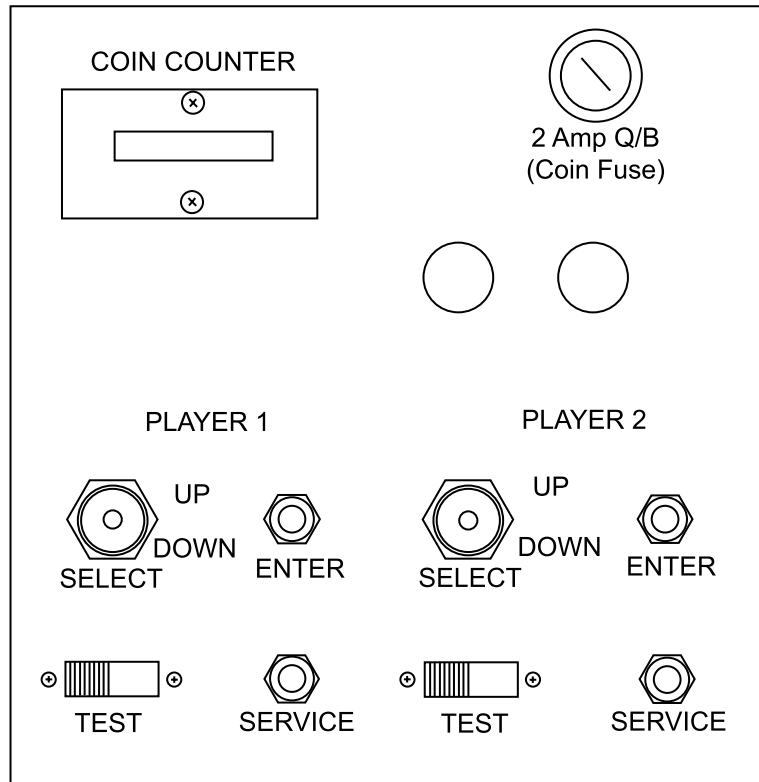

Service switch

Press this switch to increase the credit count without activating the coin counter.

Test switch

Slide this switch to ON to activate the Test mode.

The Test mode is used to change the game price and perform various tests.

(See 6-2 page 52)

Select switch

An item in the Test mode is selected by operating this switch up or down.

Enter switch

After an item is selected by using the Select switch, press the Enter switch to finalize the selection or to execute the selected item.

6-2 Test Mode

Do not enter Test if two games are being played in Linked mode. Turning on the Test switch of one unit will cause the other player's game to return to the beginning of the game and play conditions to be initialized. (score, weapon, ammunition, life and level)

1. Open the Coin Door and slide the respective Test switch ON. The following Menu screen will be displayed.

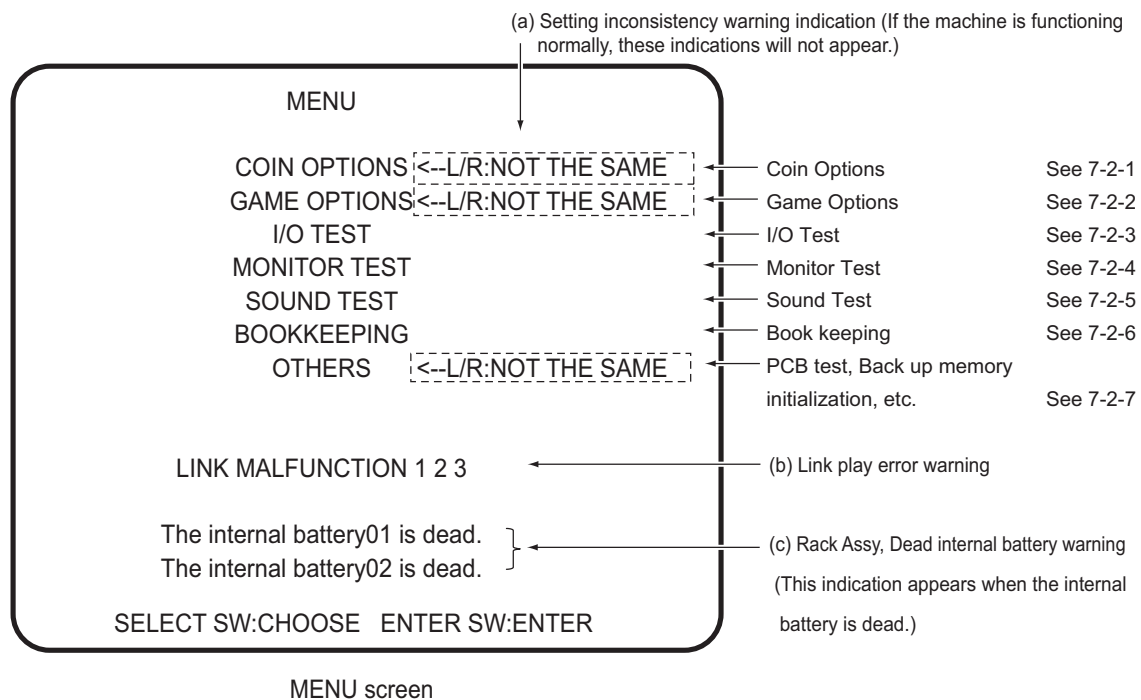

- Operate the Select switch Up or Down to step through the items available, the selected item will blink.
- Press the Enter button to enter the selected item.
- When the adjustment has been made, select EXIT and press the Enter switch. The display will return to the Menu screen.
- When all adjustments are completed, slide the Test switch to OFF. The screen will return to the Game mode.

Note: If settings are not correct, the error messages including (a), (b) and (c) shown will be displayed.

(a) Setting inconsistency warning indication

When player 1 and player 2 game parameters are inconsistent, the following message will be displayed. Check and set the correct game parameters again.

Setting inconsistency warning items	
COIN OPTIONS	GAME COST
	CONTINUE COST
	FREE PLAY
GAME OPTIONS	PLAYER'S LIFE
	DIFFICULTY
	HIT-COLOUR
OTHERS	LANGUAGE
	ATTRACT CUT

(b) Link play error warning

- This message will appear if the link play mode indicates failure. The game will run improperly while the error message is being indicated. The message on the right of the screen indicates the type of error.
- If “1” or “2” is indicated, possible error cause is circuit board malfunction (Game PC Port or NA-JV PC Board). ([See 7-5 Game PCB Assy replacement, page 76](#))
- If “3” is indicated, inconsistency exists between right and left players’ software version.

Indication	Description
ON	Normal
OFF*	Communication settings are not made, or data is not received.
NG*	Unknown data is received

(c) Dead internal battery warning

- If this warning indication appears, turn off the power switch and wait for about 10 minutes. Then, turn on the power switch and check the MENU screen in the Test mode to see if the same warning indication appears again. If the warning indication appears even though the above procedure is repeated two or three times, the internal battery capacity may be low or the Game PC Board may be defective.

6-2-1 Coin Options

This screen is used to set the price of play and free play settings.

1. Select 'COIN OPTIONS' on the Menu screen, and press the Enter button. The following screen will be displayed.

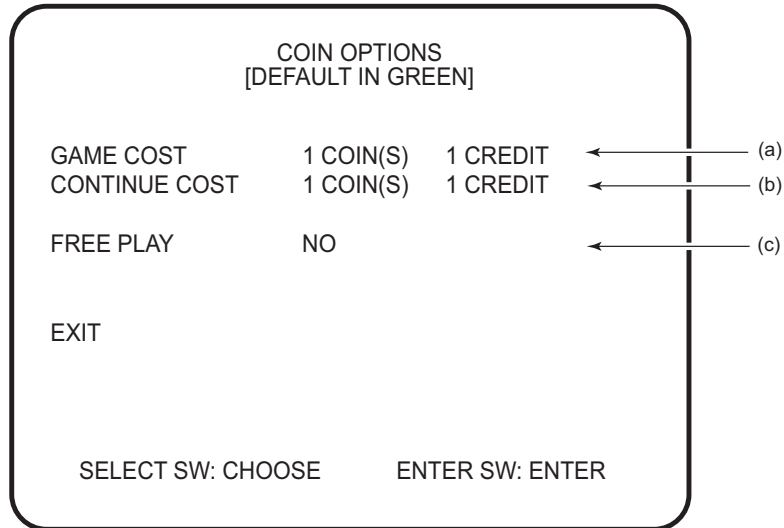

2. Use the Select switch to choose an item to be changed. The selected item is indicated in red.
3. Press the Enter Button to continue.
4. Use the Select switch to change the setting.
5. After the setting has been changed, press the Enter button to return to the selection screen.
6. When all adjustments have been made, select EXIT and press the Enter button to return to the Menu screen.

Item	Description	Default Setting
(a) Game price setting	Number of coins required for one game play 1 coin to 9 coins	1
(b) Continue game price setting *1	Number of coins required for one continue game play - 1 coin to 9 coins	1
(c) Free play setting *2	No (Disabled) YES (Enabled)	NO

*1 The number of coins for the continue game price cannot be set higher than the number of coins set for Game price. When increasing both Game and Continue game prices, increase the Game price first.

*2 When the Free Play setting is set to 'YES', the game starts when the pedal is depressed.

Note: The price of play on this game is set within the Cashflow Coin Mech. Ensure that the Game Cost is set to: 1 COIN(S) 1 CREDIT

6-2-2 Game Options

This screen is used to set the game options.

1. Select 'GAME OPTIONS' on the Menu screen, and press the Enter button. The following screen will be displayed.

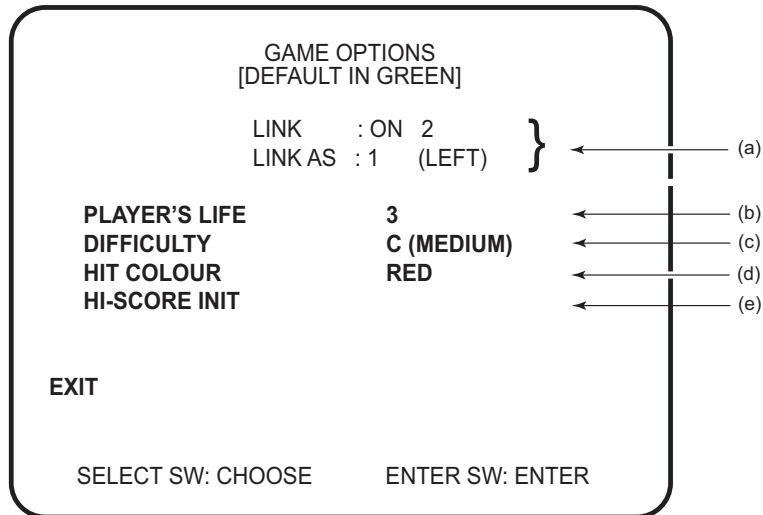

2. Use the Select switch to choose an item to be changed. The selected item is indicated in red.
3. Press the Enter Button to continue.
4. Use the Select switch to change the setting.
5. After the setting has been changed, press the Enter button to return to the selection screen.
6. When all adjustments have been made, select EXIT and press the Enter button to return to the Menu screen.

Note: If the difficulty level setting (c) is not the same for both Player 1 and Player 2, the game will not operate correctly.
Ensure that the difficulty level is the same for both Player 1 and Player 2.

Item	Description	Default Setting
(a)	Communication status indication	See '6-2-3 I/O Test' page 54
(b)	Player's LIFE setting	Number of Lives at game start - 1~9 3
(c)	Difficulty level setting	A (VERY EASY) B (EASY) C (MEDIUM) D (HARD) E (VERY HARD) C (MEDIUM)
(d)	Hit colour setting	RED/GREEN RED
(e)	High score initialize	When this item is selected and entered, the screen displays "HIGH SCORE INITIALIZE ?" and prompts for input "YES" or "NO." NO: Returns to the screen displayed prior to the "HI-SCORE INITIALIZE" message. YES: Initializes the high score data.

6-2-3 I/O Test

This screen is used to set the game options.

1. Select 'GAME OPTIONS' on the Menu screen, and press the Enter button. The following screen will be displayed.

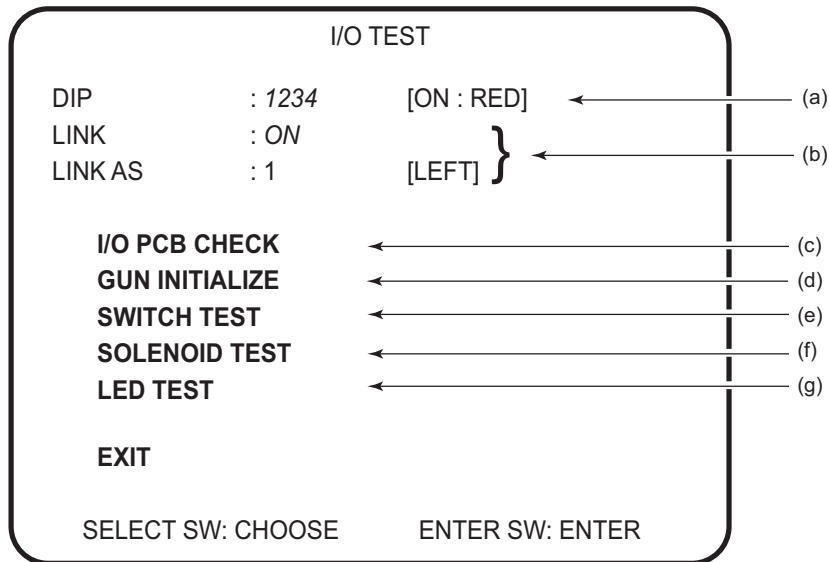

2. Use the Select switch to choose an item to be changed. The selected item is indicated in red.
3. Press the Enter Button to continue. The selected test screen will be displayed.
4. When all tests have been made, select EXIT and press the Enter button to return to the Menu screen.

(a) DIP Switch Settings

Displays the setting of the DIP switches. Switches set to ON will be shown in red. All DIP switches should be set to OFF

(b) Link Check

Indicates the communication status between Player 1 and Player 2

LINK AS: 1 (LEFT) - The screen on the left

2 (RIGHT) - The screen is on the right.

§ If 'LINK OFF' or 'LINK NG' is indicated, the game will not operate correctly.

- (c) Indicates condition of the I/O PC board. [\(see 6-2-3-1 page 57\)](#)
- (d) Used to Initialize the gun sighting. [\(see 6-2-3-2 page 58\)](#)
- (e) Used to test game switches. [\(see 6-2-3-3 page 61\)](#)
- (f) Used to test the gun recoil solenoid. [\(see 6-2-3-4 page 62\)](#)
- (g) Used to test the Display LEDs. [\(see 6-2-3-5 page 63\)](#)

6-2-3-1 I/O PCB Check

This screen is used to check the I/O PC board, and to display the software version number.

1. Select 'I/O PCB CHECK' on the I/O Test Menu screen, and press the Enter button. The following screen will be displayed.

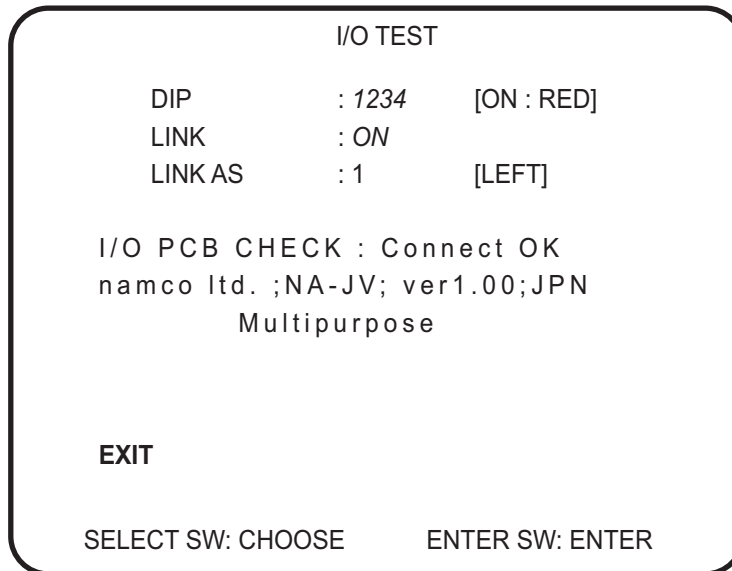

- 2 Press the Enter button to return to the I/O Test Menu Screen.

Note: There are no adjustments available on this screen.

6-2-3-2 Gun Initialize

This screen is used to adjust the gun sight.

1. Select 'GUN INITIALIZE' on the I/O Test Menu screen, and press the Enter button, or slide the Test switch ON while pressing the Enter button. The following screen will be displayed.

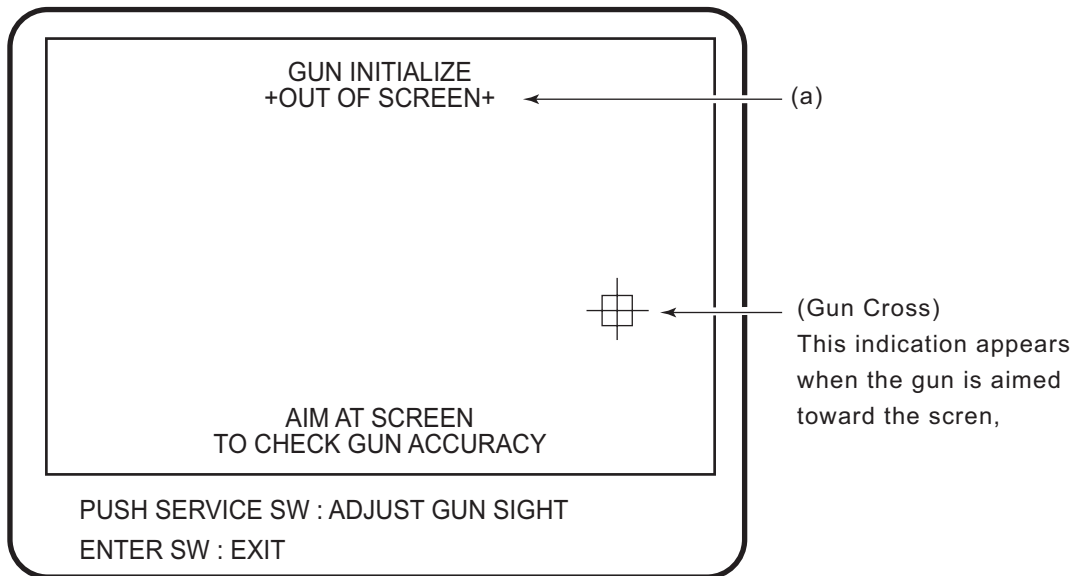

2. The Gun Assy's sighting can be checked on the above screen. When the gun is aimed at the screen, the gunsight (crosshairs) will appear on the screen. Ensure that the gun is aimed within the rectangle and that the sight is in the correct position. (Check all areas of the screen.) When the gun is aimed outside of the rectangle, the 'OUT OF SCREEN' message should be displayed at position (a). If the 'OUT OF SCREEN' message frequently appears even though the gun is aimed within the rectangle check the following:
 - Bright light shining or reflecting on the LEDs around the screen.
 - Gun Assy too close to the screen. (less than 60cm)
 - The gun is at too great an angle to the screen.

Either move the machine or reduce the lighting and aim with the correct distance and angle. If the problem still persists or if the gun sight (crosshair) is not displayed in the correct position, continue with the following:

3. Press the Service button, or step on the pedal, while "GUN INITIALIZE !" screen is displayed. The following GUN INITIALIZE 2 screen will be displayed.

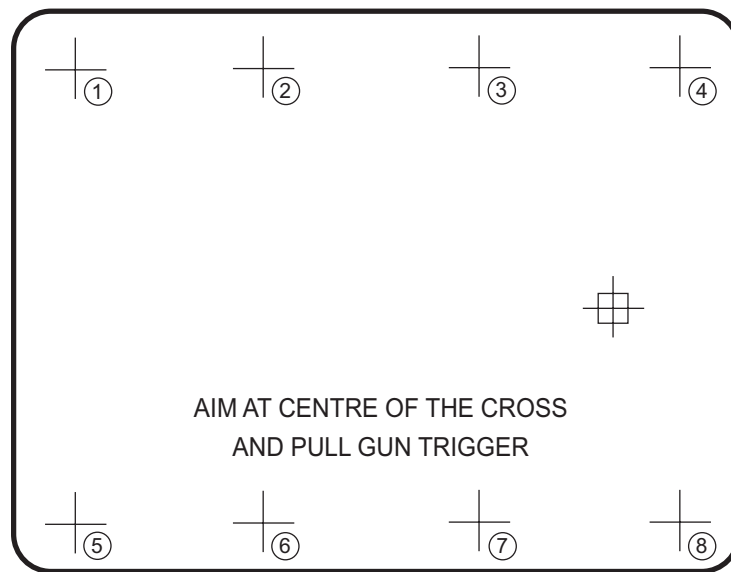

GUN INITIALIZE screen (2)

The gun sight adjustment is made by aiming and pulling the trigger at eight targets (four targets each at top and bottom of the screen.)

Aim the gun at the centre of each target that is displayed and pull the trigger. Each time the trigger is pulled the next target will be displayed on the screen in the order shown above. After the eighth target is shot, the GUN INITIALIZE 1 screen will appear to confirm aiming.

4. When adjustment is completed press the Enter button to return to the I/O Test Menu Screen.

When adjusting the gun sight, follow the procedures below

- Hold the Gun Assy towards the screen so that the top edge of the rear sight of the gun aligns with the horizontal line of the crosshairs (+) on the screen.
- Bring the top edge of the front sight at the tip of the Gun Assy so that it also aligns with the horizontal line of the crosshairs (+) on the screen.
- Make sure that the centre of the rear sight and the centre of the front sight are at the centre of the crosshairs (+), and shoot the Gun Assy.
- Be sure to hold the Gun Assy straight. Do not tilt the Gun Assy.

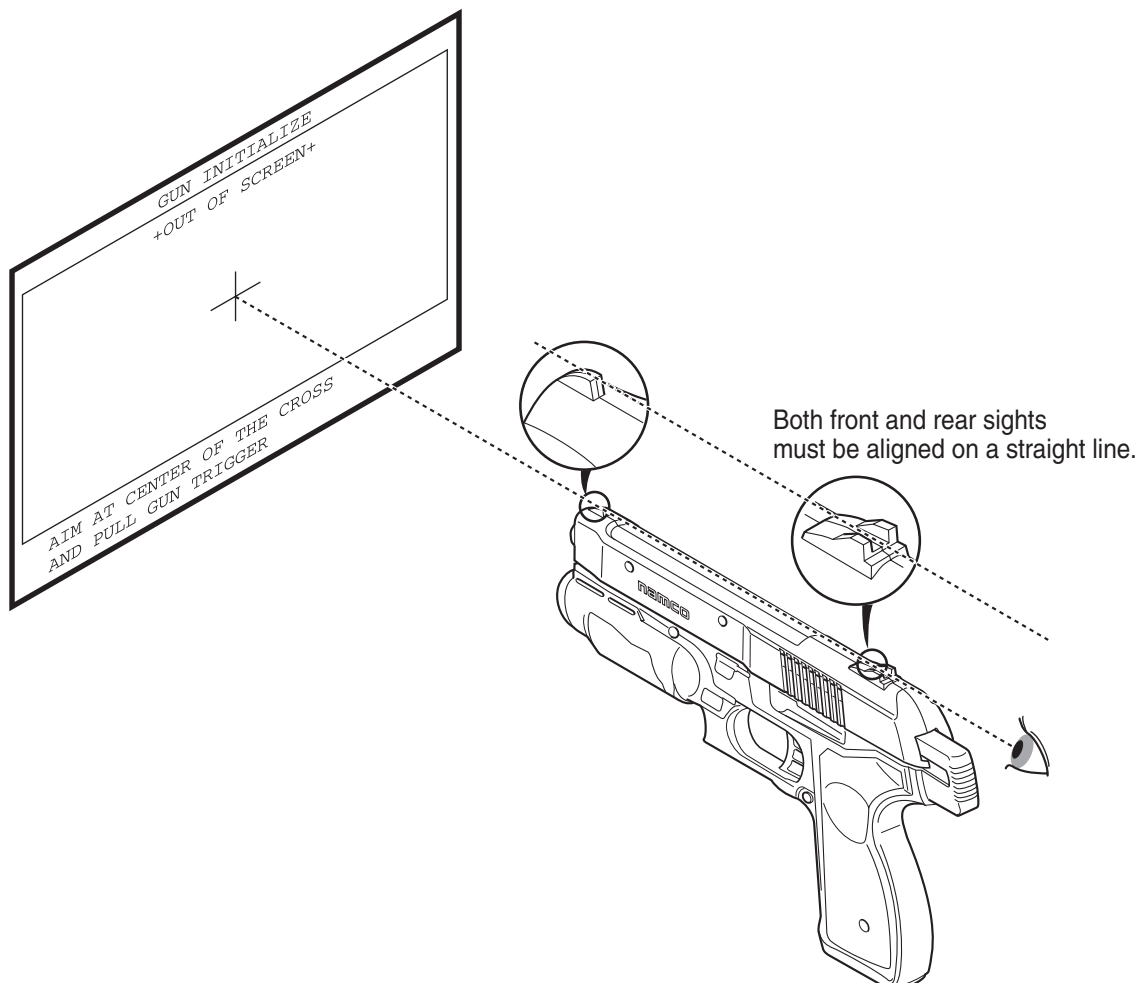
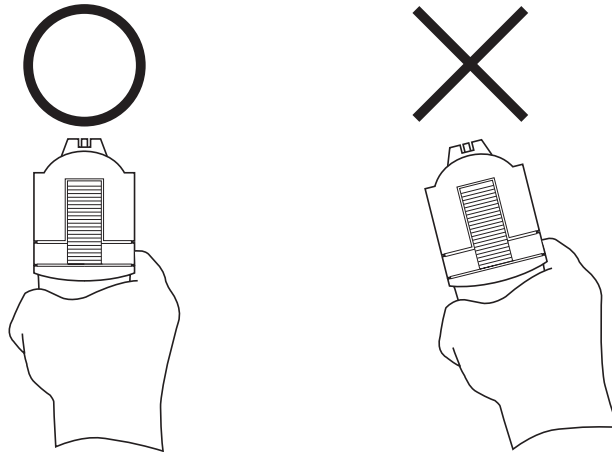

6-2-3-3 Switch Test

This screen is used to test the game switches.

1. Select 'SWITCH TEST' on the I/O TEST Menu screen, and press the Enter button. The following screen will be displayed.

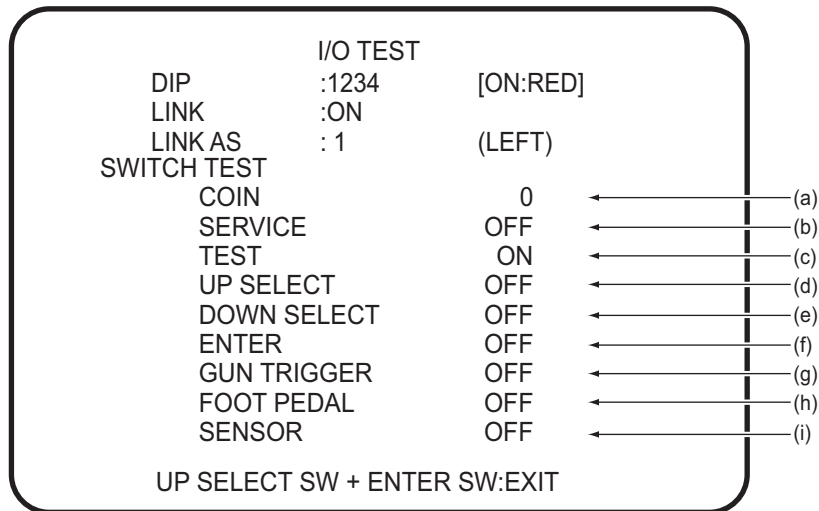

SWITCH TEST screen

2. When a switch is pressed, the corresponding display on the screen will change.
 - (a) The displayed number will increment each time sufficient coins for a credit are inserted through the Cashflow.
 - (b) Changes to ON each time the Service button is pressed.
 - (c) This will always display ON as the game is in test.
 - (d) Changes to ON each time the Select switch is pushed Up.
 - (e) Changes to ON each time the Select switch is pushed Down.
 - (f) Changes to ON each time the Enter button is pressed.
 - (g) Changes to ON each time the Gun Trigger is pulled.
 - (h) Changes to ON each time the Pedal is depressed.
 - (i) Changes to ON each time the Gun Assy is aimed at the screen.
3. When testing is complete, press the Enter button while holding the Select switch UP to return to the I/O Test Menu screen.

6-2-3-4 Solenoid Test

This screen is used to test the Gun Assy's recoil mechanism.

1. Select 'SOLENOID TEST' on the I/O TEST Menu screen, and press the Enter button. The following screen will be displayed.

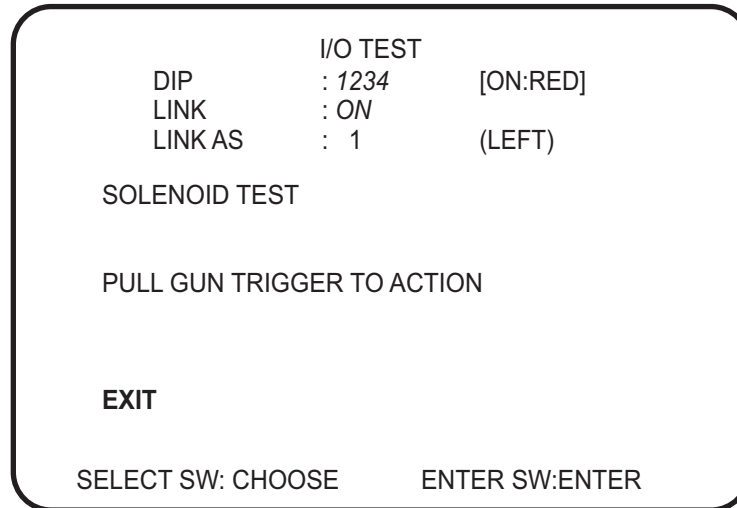

SOLENOID TEST screen

2. The Gun Assy's Solenoid will operate each time the trigger is pulled.
3. Select 'EXIT' and press the Enter button to return to the I/O Test Menu screen.

6-2-3-5 LED Test

This screen is used to test the Side LED PC board.

1. Select 'LED TEST' on the I/O TEST Menu screen, and press the Enter button. The following screen will be displayed.

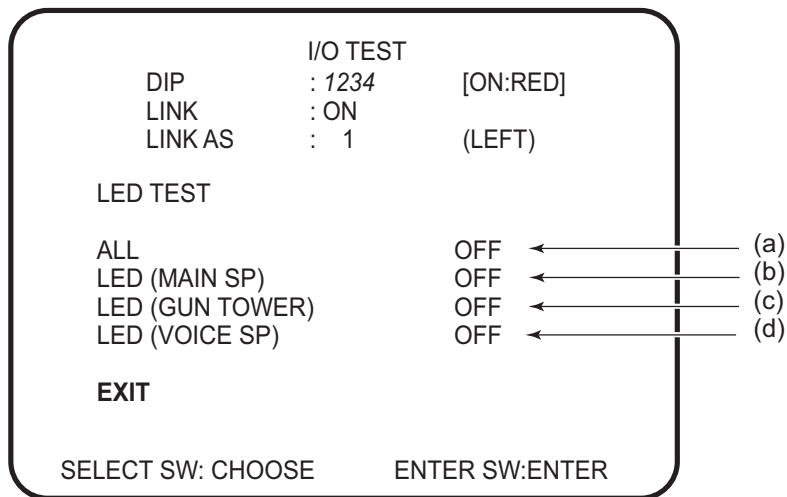

LED TEST screen

2. Use the Select switch to choose an item to be checked. The selected item is indicated in red.
3. Press the Enter Button to continue.
4. Use the Select switch to turn the LEDs On or OFF.

Indication	Status
(a) ALL	Turn all LEDs ON or OFF.
(b) LED (Main SP)	Turn the main speaker assy's LEDs located on the upper part of the Monitor Cabinet ON or OFF.
(c) LED (GUN TOWER)	Turn the LEDs located on the front acrylic panel of the Gun Tower Assy ON or OFF.
(d) LED (VOICE SP)	Turn the speaker assy's LEDs located on the upper part of the Gun Tower assy ON or OFF.

5. When all testing has been completed, select EXIT and press the Enter button to return to the I/O Test Menu screen.

6-2-4 Monitor Test

This screen is used for monitor adjustments.

1. Select 'MONITOR TEST' on the TEST Menu screen, and press the Enter button. The following screen will be displayed.

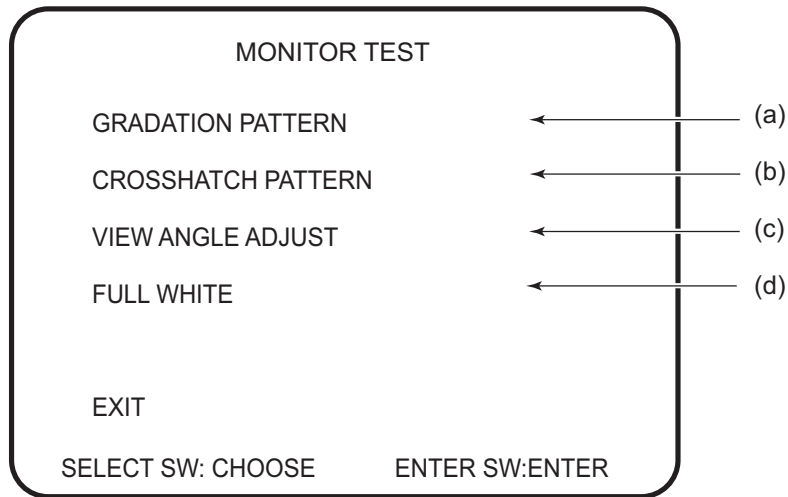

MONITOR TEST screen

2. Use the Select switch to choose an item to be changed. The selected item blinks.
3. Press the Enter Button to display the selected pattern. (Pressing the Enter button again will return to the above Monitor Test screen)
4. When all adjustments have been made, select EXIT and press the Enter button to return to the Test Menu screen.

Indication	Status
(a) Gradation Pattern	Displays graduated colour bars for colour set-up
(b) Crosshatch Pattern	Displays a crosshatch for geometry set-up
(c) View Angle Adjust	Displays a white border for picture size set-up
(d) Full white	Displays a white screen for brightness / contrast set-up

6-2-5 Sound Test

This screen is used to set the sound level and to test the stereo sound reproduction.

1. Select 'SOUND TEST' on the Menu screen, and press the Enter button. The following screen will be displayed.

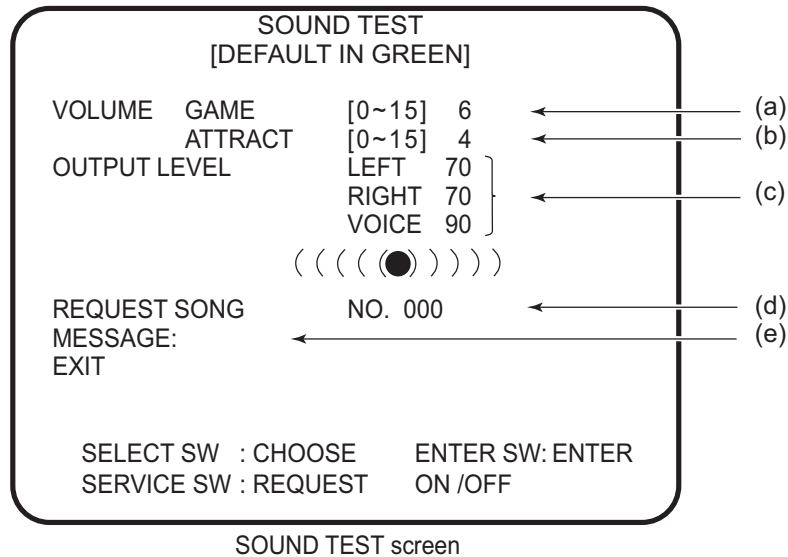

2. Use the Select switch to choose an item to be changed. The selected item is indicated in red.
3. Press the Enter Button to continue.
4. Use the Select switch to change the setting.

When item (d) is selected, each time the Enter button is pressed, the adjustment digit changes. Use the Select switch to change the value of each digit to set a desired number. When the Service button is pressed, the music or sound effect of the selected number will be reproduced.

When '000' is selected and the Service button pressed, sound will be produced by the left speaker, right speaker, voice speaker and woofer in that order. The volume reference ('GAME' or 'ATTRACT') and the present sound reproduction 'LEFT', 'RIGHT', 'VOICE' or 'WOOFER' will be displayed at position (e).

5. When all adjustments have been made, select EXIT and press the Enter button to return to the Menu screen.

6-2-6 Bookkeeping

This screen is used to view various game data.

1. Select 'BOOKKEEPING' on the Menu screen, and press the Enter button.
2. Displayed game data cannot be reset in this screen. To clear data execute 'INITIALIZE' or 'BACK-UP MEMORY'
3. After checking the game data select 'EXIT' and press the Enter button to return to the Test Menu screen.

6-2-7 Others

This screen is used to set language and initialize back-up memory.

1. Select 'OTHERS' on the Menu screen, and press the Enter button. The following screen is displayed.

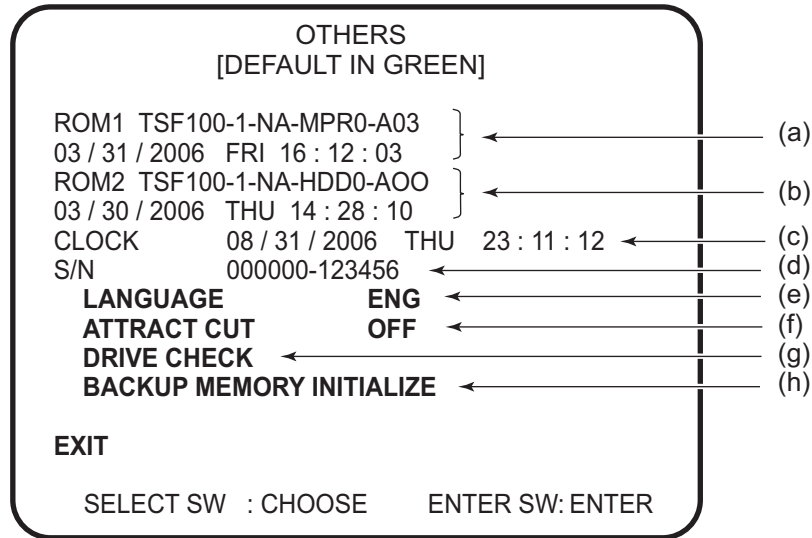

OTHERS screen

2. Use the Select switch to choose an item to be changed. The selected item is indicated in red.
 3. Press the Enter Button to continue.
 4. Use the Select switch to change the setting. Pressing the Enter switch returns to the selection menu screen.
 5. When all adjustments have been made, select EXIT and press the Enter button to return to the Menu screen.
- (a) Displays the version of ROM 1 which contains the program.
 (b) Displays the version of ROM 2 which contains data.
 (c) Displays the current time set in the internal clock.
 (d) Displays the software serial number.
 (e) Sets the on screen language.
 (f) The default setting is 'OFF'. If 'ON' is selected, violent scenes will be skipped during the attract mode.
 (g) Checks data saved in the HDD. (This item is not used in normal operation).
 (h) Initializes back-up memory.
 Selecting 'YES' and then pressing the Enter button clears the gun sight setting, high score date, play data and other variables, and then returns the game to its default condition.

Note: If the software versions displayed at (a) and (b) are different in TEST mode for player 1 and player 2, the game will not function correctly.

7. MAINTENANCE

- GB** Adjustment or maintenance on this machine should be carried out by qualified personnel only.
Ensure that the POWER to the machine is turned OFF before commencing any maintenance work. (Trouble shooting, service or repairs etc.)
- D** Einstellungen und Wartung des Gerätes dürfen nur von dafür qualifiziertem Fachpersonal vorgenommen werden.
Vor Beginn aller Wartungsarbeiten (Fehlersuche, Reparaturen etc.) muß der Netzstecker gezogen werden.
- DK** Justeringer eller vedligehold af denne maskine bør kun udføres af kvalificeret personale.
Sørg for, at strømmen til maskinen er slukket før der foretages nogen form for arbejde (fejlfinding, reparation etc.)
- E** Los ajustes y el mantenimiento de esta máquina deben ser realizados sólo por personal cualificado.
Asegúrese de que la máquina está desconectada antes de comenzar cualquier trabajo de mantenimiento (reparaciones, resolución de problemas, etc.)
- F** L'installation, le service, le réglage, ou la maintenance doivent être effectués uniquement par les personnes qualifiées.
S'assurer que l'interrupteur soit sur OFF avant de commencer tout travail de maintenance (localisation d'une panne, réparations, etc.)
- GR** Μετατροπές ή επιδιορθώσεις στα μηχανήματα πρέπει να γίνονται μόνο από εξουσιοδοτημένα άτομα.
Να είναι σίγουρα κλειστό το ρεύμα πριν οποιαδήποτε δουλειά στο μηχάνημα.
- I** Regolazioni e manutenzione su questa macchina devono essere fatti solo da personale specializzato.
Assicurarsi che la macchina sia SPENTA prima di incominciare qualsiasi lavoro di manutenzione (guasti, riparazioni etc.)
- N** Justering eller vedlikehold på denne maskinen skall bare utføres av kvalifiserte personell.
Forsikre deg om at strømmen er slått av før du påbegynner noe som helst vedlikeholdsarbeid (feilsøking, reparasjon osv.)

- (NL)** Aanpassingen of onderhoud aan deze machine dient alleen uitgevoerd te worden door bekwaam personeel.
Zorg ervoor dat de machine UITgeschakeld is voordat er enig onderhoudswerk wordt verricht (troubleshooting, reparaties etc.)
- (P)** Afições ou manutenção nesta maquina, deverão ser efectuadas sómente por pessoal qualificado.
Certifique-se que a maquina se encontra desligada sempre que iniciar qualquer tipo de trabalho de manutenção. (identificação de avarias, reparação etc.)
- (S)** Justeringar och underhåll på denna maskin skall endast utföras av kvalificerad personal.
Försäkra dig om att strömmen är avstängd innan underhållsarbete påbörjas (felsökning, reparationer etc.)
- (SF)** Tätä laitetta saa säätää tai huoltaa vain siihen ammattipätevyyden omaava henkilökunta.
Varmista, että laite on kytketty POIS PÄÄLTÄ ennen työn aloittamista.

7-1 Cleaning

Do not use organic solvents such as thinners or petroleum. They can cause deterioration of the material surfaces.

To clean the machine, wipe with a dry soft cloth. If the unit is extremely dirty, use a soft cloth dampened with a neutral detergent to remove the dirt, and then rub lightly with a cloth dampened slightly with water. Finally, wipe thoroughly dry with a soft cloth.

7-1-1 Cleaning the Gun Assy

Clean the tip of the barrel everyday to maintain gun accuracy. Use a clean soft cloth to wipe the tip of the barrel.

- Do not use detergents or chemicals for cleaning.
- Be careful not to damage the tip of the barrel.

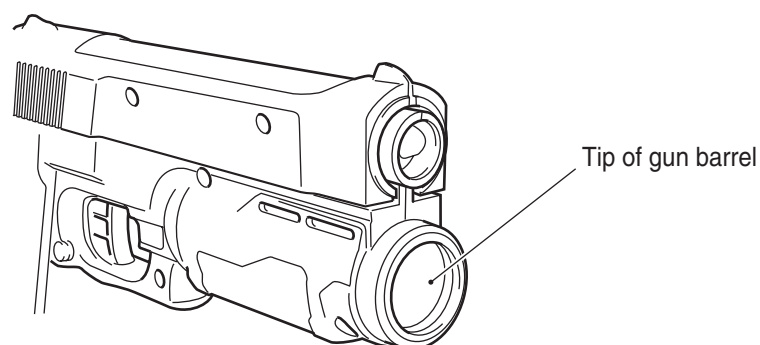

7-1-2 Cleaning the Front Acrylic Cover

Clean the following sensor section's filters (20 locations) on the Monitor Mask everyday to maintain gun accuracy. Clean the filter on the LED board with a soft cloth to prevent scratching the surface. Scratches on the monitor mask can affect the Gun Assy detection performance.

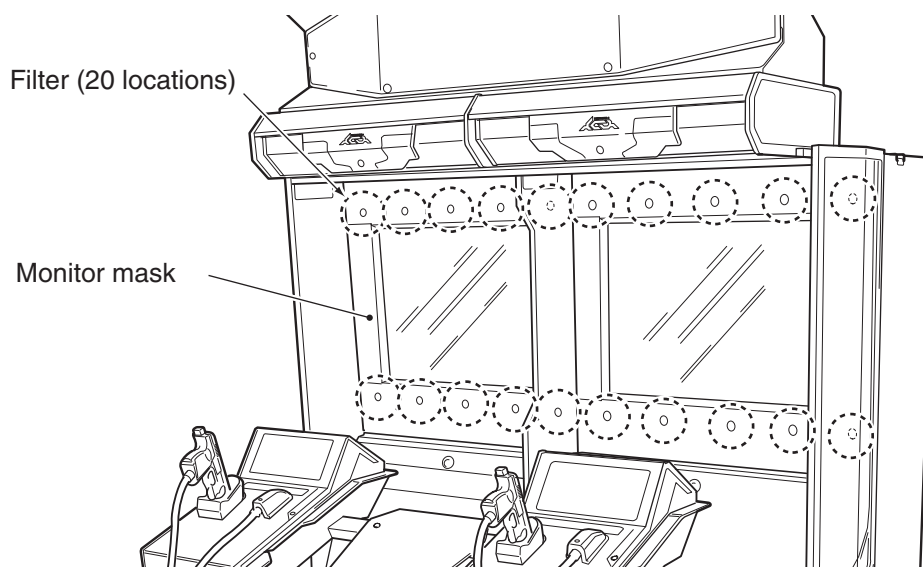

7-2 Regular Maintenance

The following should be conducted at least once every six months.

7-2-1 Greasing the Pedal Plunger

1. Remove 4 off flange socket screws (M6x12) from the Pedal Assy. Withdraw the Pedal Assy only sufficient to disconnect the connector. Disconnect the connector and remove the Pedal Assy.

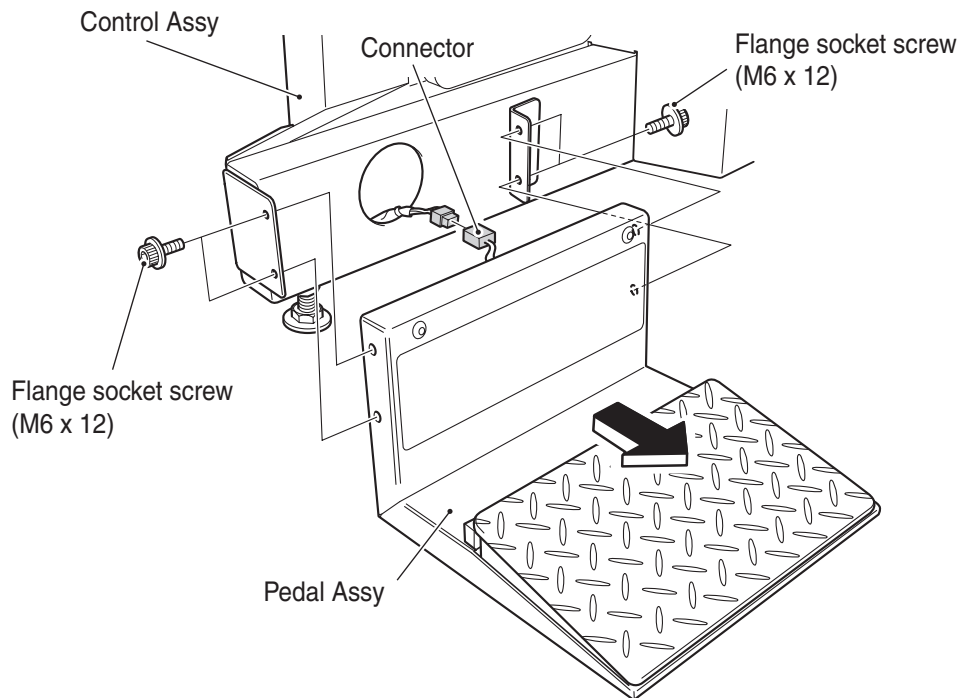

2. Remove 4 off pozi head screws (M5x12) and remove the Cover (M).

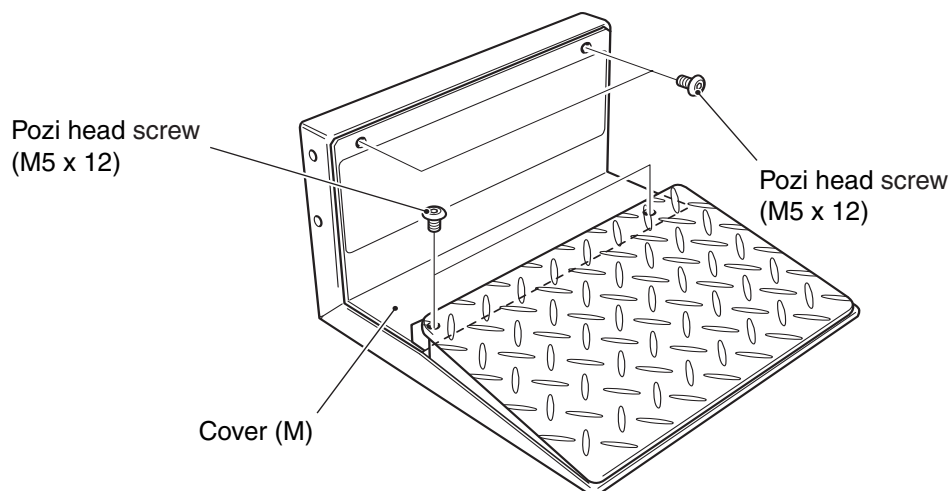

3. Remove 4 off whizz nuts (M4) retaining the Holder. While holding the Plunger in, remove the holder with plunger.
Note: The plunger is spring loaded, take care that the plunger and spring do not fly off.
4. Wipe away any old grease from the Plunger and Plate surface on the Pedal.
5. Apply a light grease to the Plate and spherical surface of the Plunger.

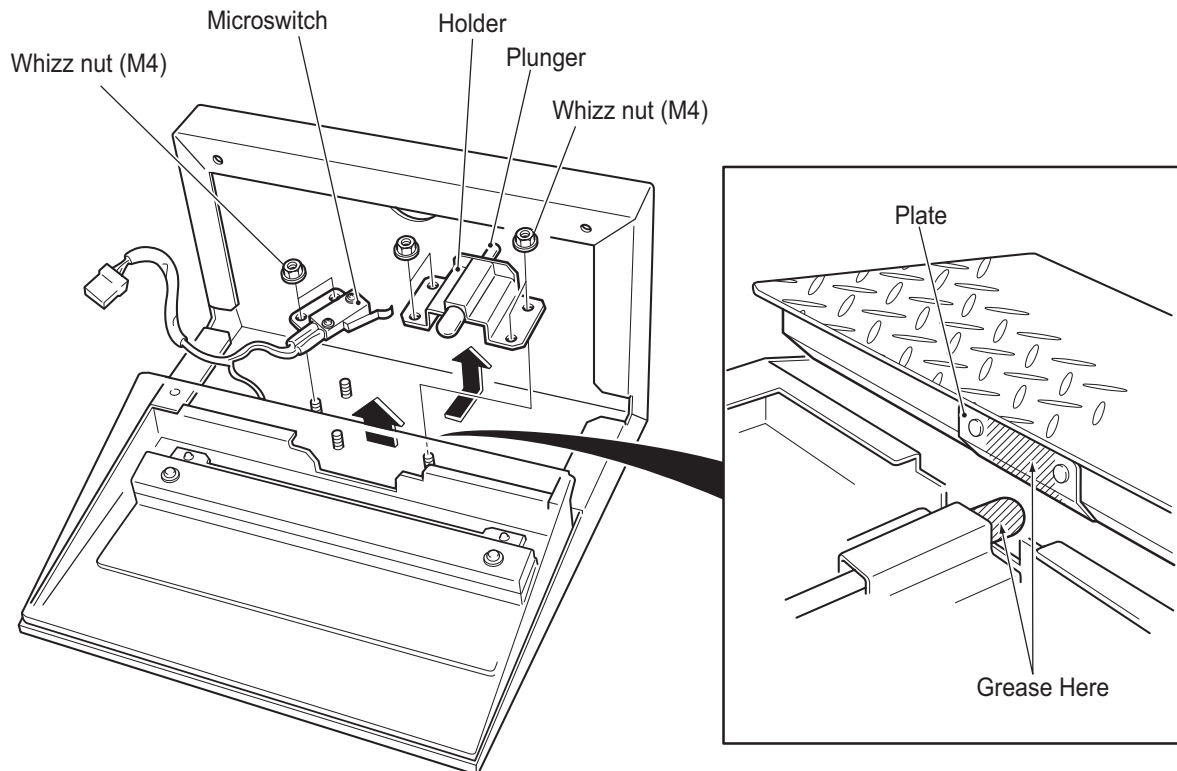

6. Reassemble in reverse.

Note: After reassembly, check the operation of the Pedal Assy.
[\(see 6-2-3-3 page 61\)](#)

7-2-2 Checking the Plunger for Wear

1. Remove 4 off Poz head screws (M5x12) and remove the cover (M)

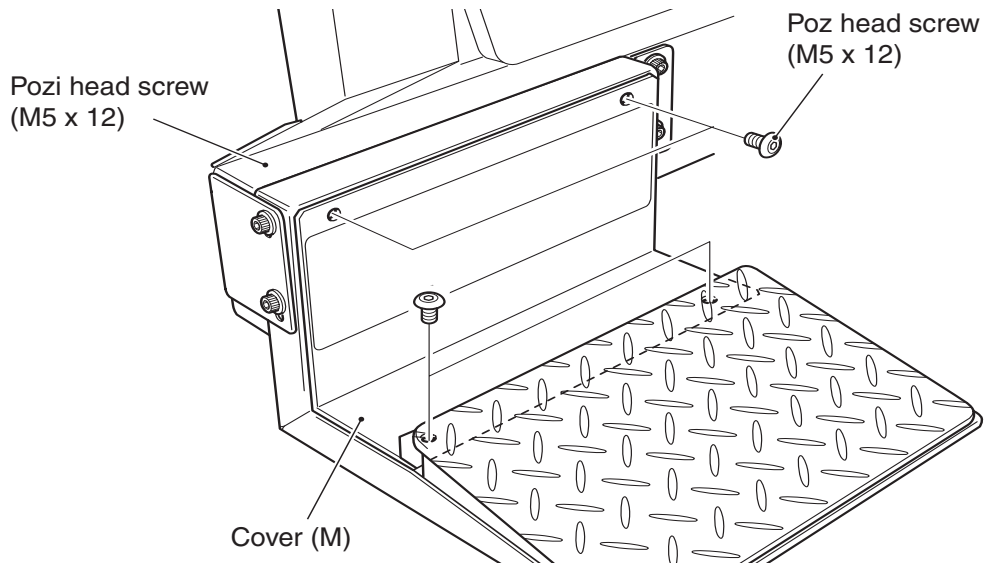

2. Depress the Pedal by hand and visually check that the Plunger operates the Micro Switch.

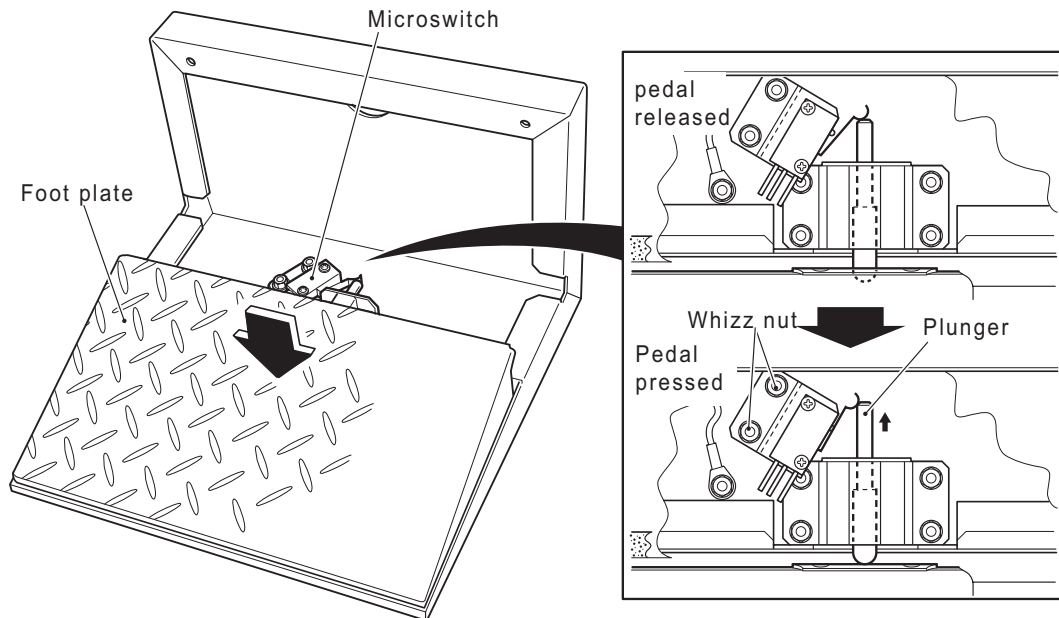

3. If the Plunger is worn and does not operate the Micro Switch, replace the Plunger.
4. Reassemble in reverse order.

7-3 Removing the Monitor Mask

1. Remove 2 off security screws (M5x25), undo the lock and remove the Front Door.

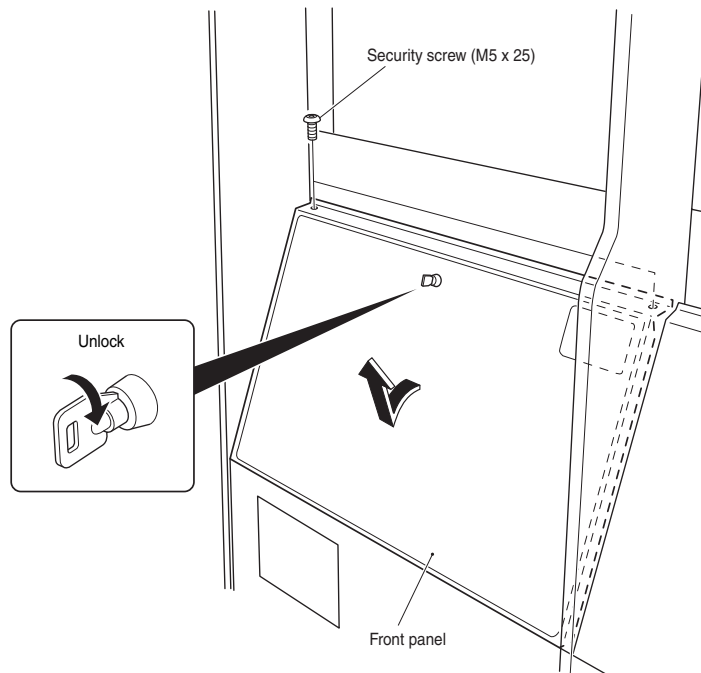

2. Disconnect the connector.
3. Remove 4 off security screws (M5x25) and remove the Monitor Mask.

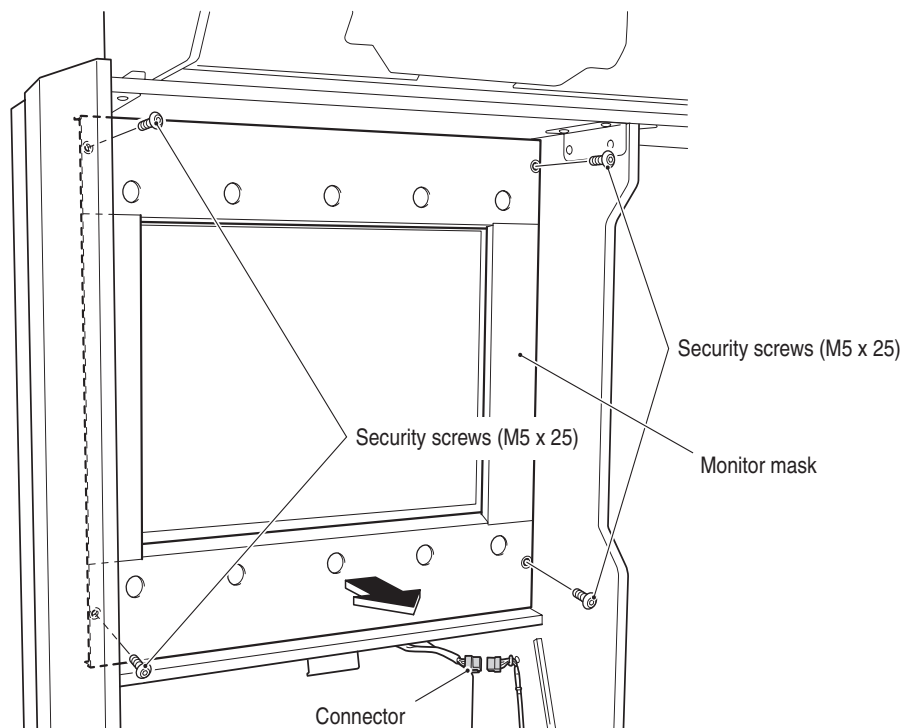

4. Reassemble in reverse order.

7-4 Replacing the LED Board



- **The LED Board can be damaged by static electricity. Before handling the LED Boards, always touch an earthed metal surface to discharge any static electricity.**
-
- If the two LEDs (red spots) under the Monitor Mask's filter (see illustration below) do not illuminate, the LED board may be defective or malfunctioning. As any defective LED Board will prevent the proper functioning of the game, replace the defective LED Board as soon as possible.
1. Remove the Monitor Mask. (see 7-3 page 74)
 2. Disconnect the LED Board's two connectors, remove 2 off whizz nuts (M3), and remove the defective LED Board.

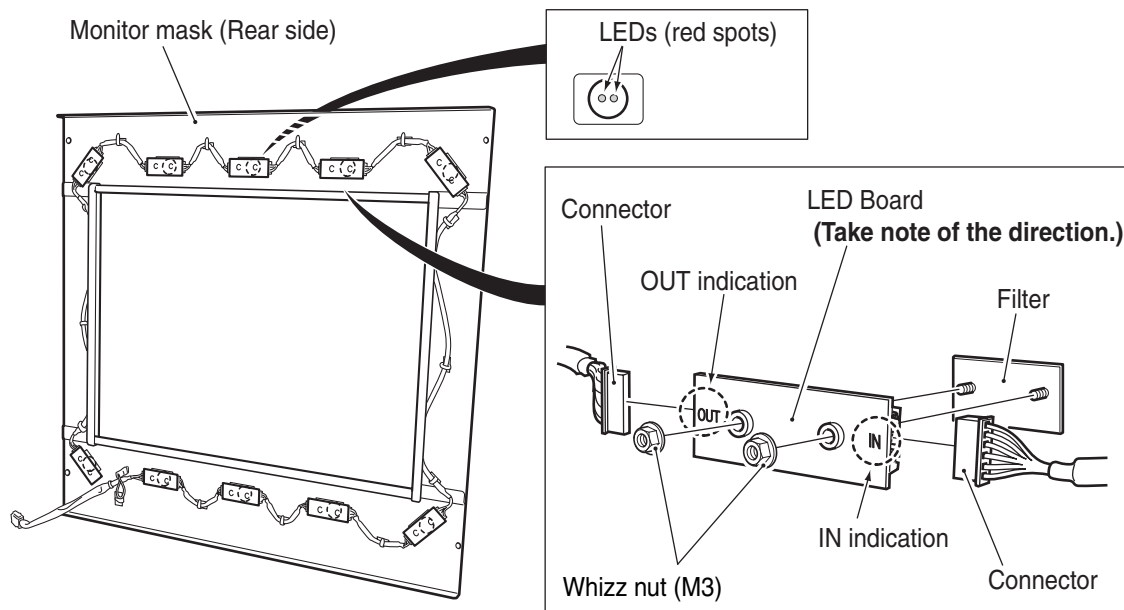

3. Reassemble in reverse order.

Note: Ensure that the LED Board is the correct way round.

7-5 Replacing the Game PCB Assy



- **The Game PCB Assy can be damaged by static electricity. Before handling the Game PCB Assy, always touch an earthed metal surface to discharge any static electricity.**

1. Remove the Front door. (see 7-3 page 74)
2. Disconnect the four connectors, and remove 1 off pozi head screw (M4x6) to remove the Earth terminal.
3. Remove 4 off nuts (M6) and spring washers, and remove the Game PCB Assy.

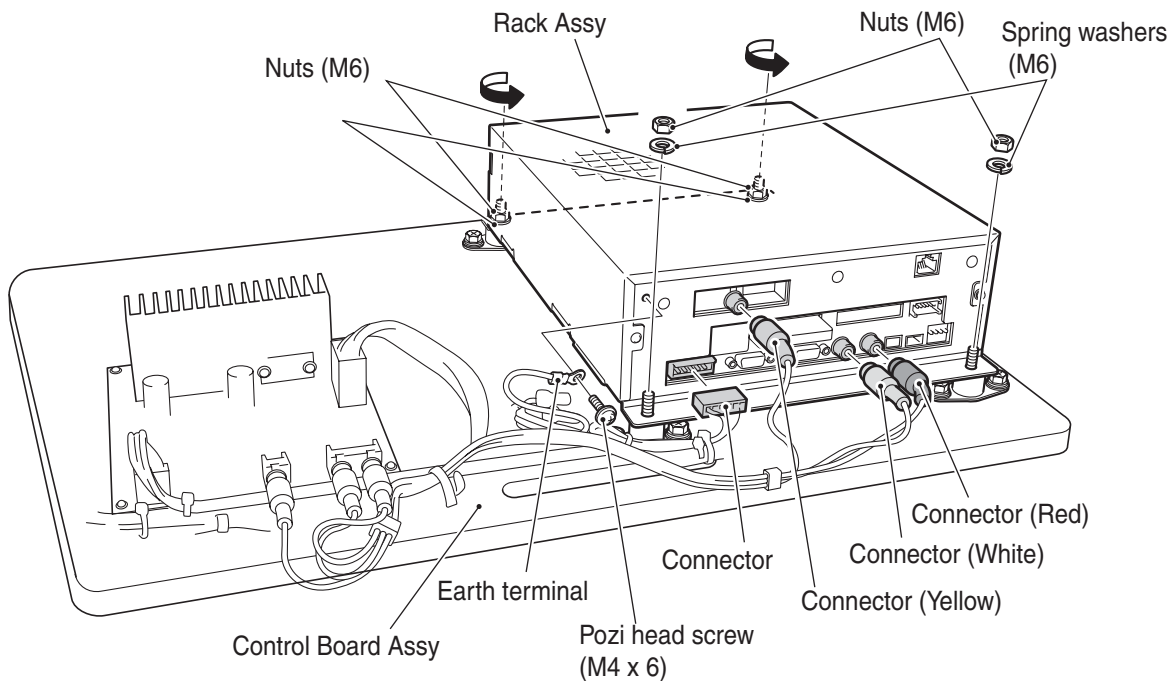

4. Reassemble in reverse order.

7-6 Replacing the Amp PC Board



- **The Amp PC Board can be damaged by static electricity. Before handling the AMP Board, always touch an earthed metal surface to discharge any static electricity.**

1. Remove the Front door. (see 7-3 page 74)
2. Disconnect the five connectors. Remove 5 off pozi head screws (M3x6), with flat and spring washers, and remove the Amp PC Board.

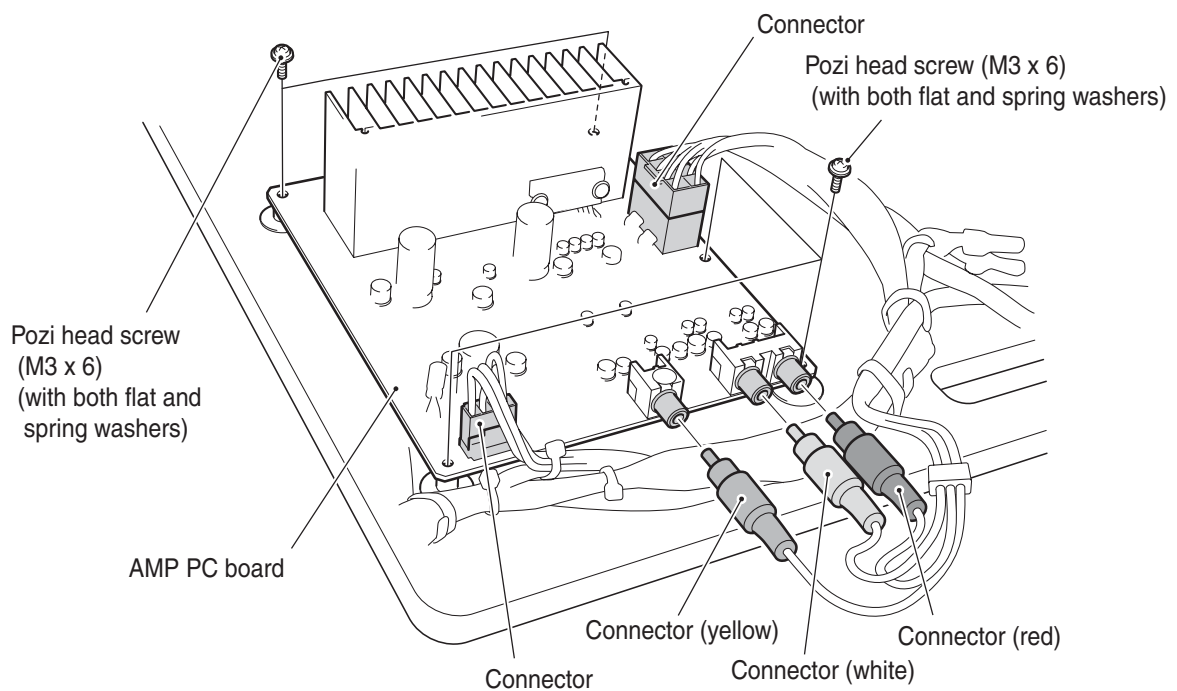

3. Reassemble in reverse order.

7-7 Replacing the SIDELED PC Board (Header Assy)



- The SIDELED PC Board can be damaged by static electricity. Before handling the SIDELED Board, always touch an earthed metal surface to discharge any static electricity.
- The red colour seal is affixed to the SIDELED (R) PC Board. The blue colour seal is affixed to the SIDELED (B) PC Board.

1. Remove the Panel washer and countersunk flat head screws(M5x8) and remove the Speaker Front Panel.

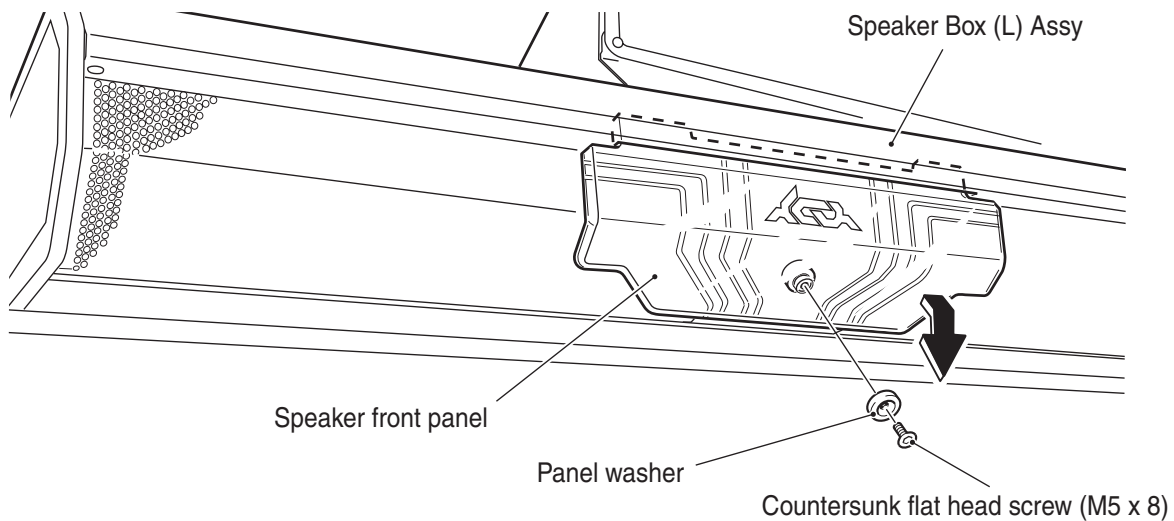

2. Remove 3off cap screws (M5x12), disconnect the connector, and remove the Top Braid.

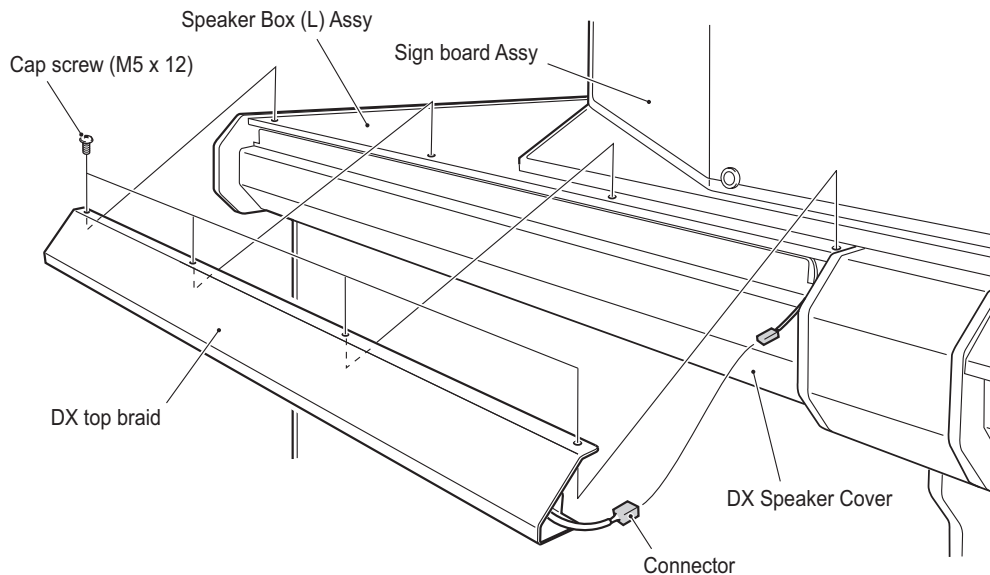

3. Remove 2 off cap screws (M4x6), and remove the LED Bracket
4. Remove 3 off pozihead screws (M3x6), with flat and spring washers. Disconnect the connector and remove the SIDELED PC Board from the LED bracket.

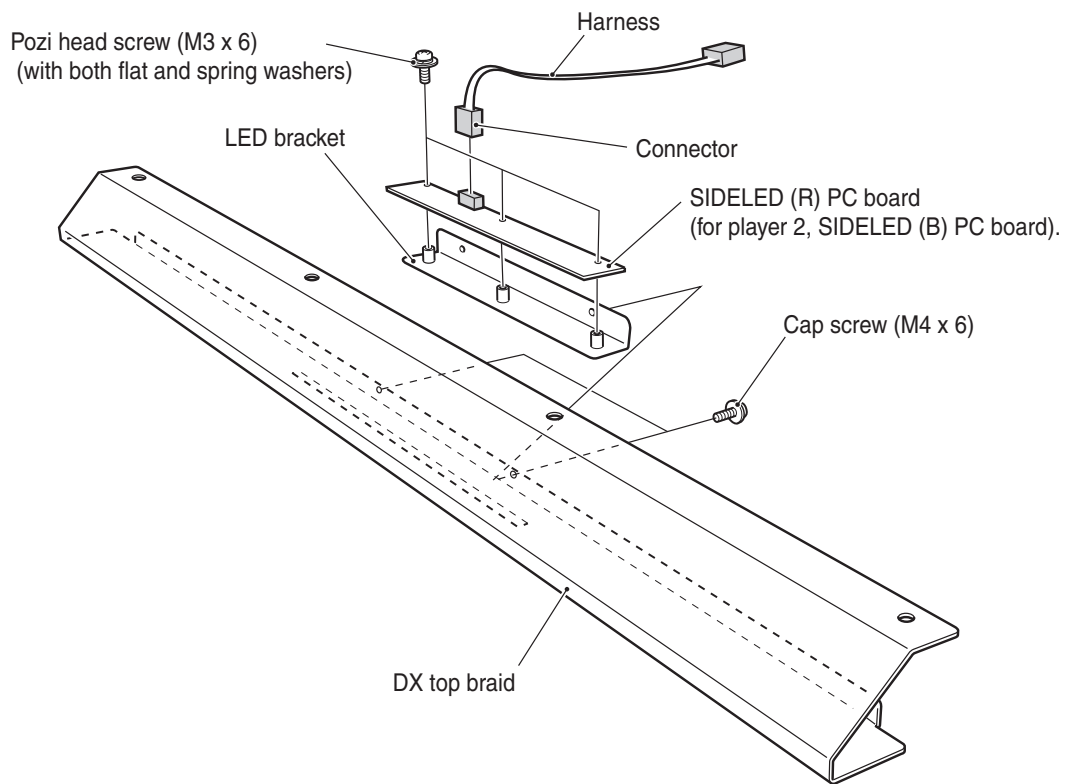

5. Reassemble in reverse order.

7-8 Replacing the Fluorescent Tube / Starter



- The fluorescent lamp may be hot. Take care when removing the fluorescent lamp.
- Take care when replacing the fluorescent lamp or starter, as the work must be conducted at height.

- 1 Remove six off countersunk flat head screws (M5x8), 6off panel washers, and remove the Header Panel.
2. Replace the Fluorescent Tube and/or Starter.

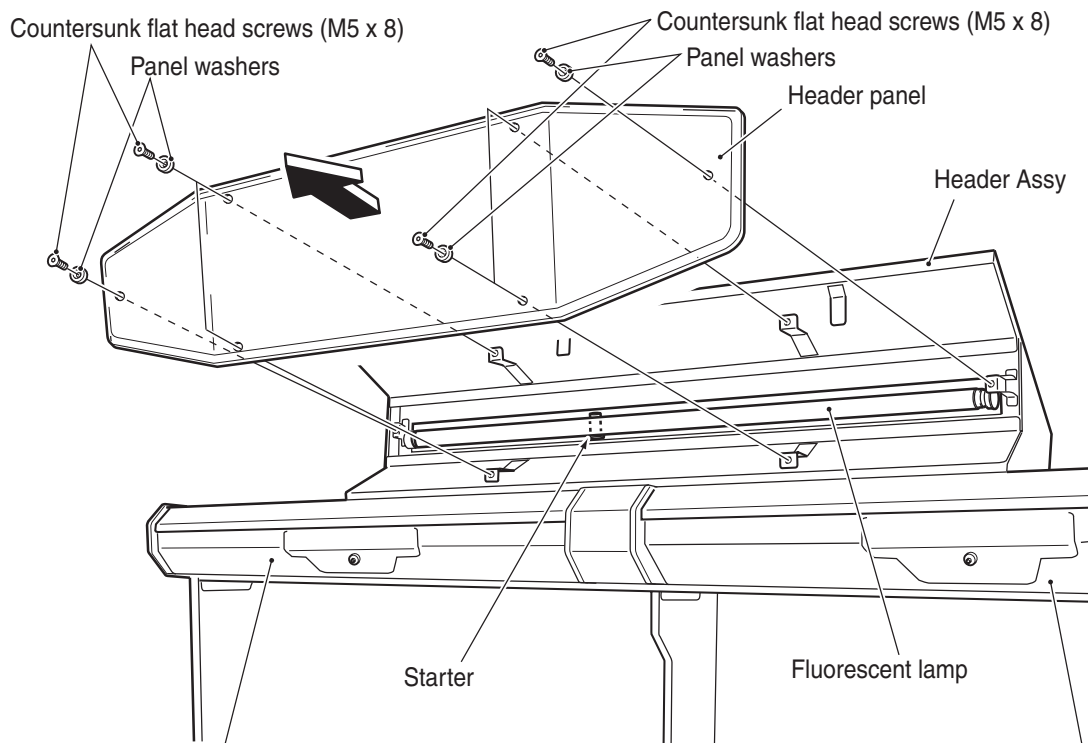

3. Reassemble in reverse order.

7-9 Removing the Control Panel

1. Remove 6 off security screws (M5x16).
2. Raise the Control Panel only sufficient to access the connectors.
3. Disconnect the connectors and remove the Control Panel.

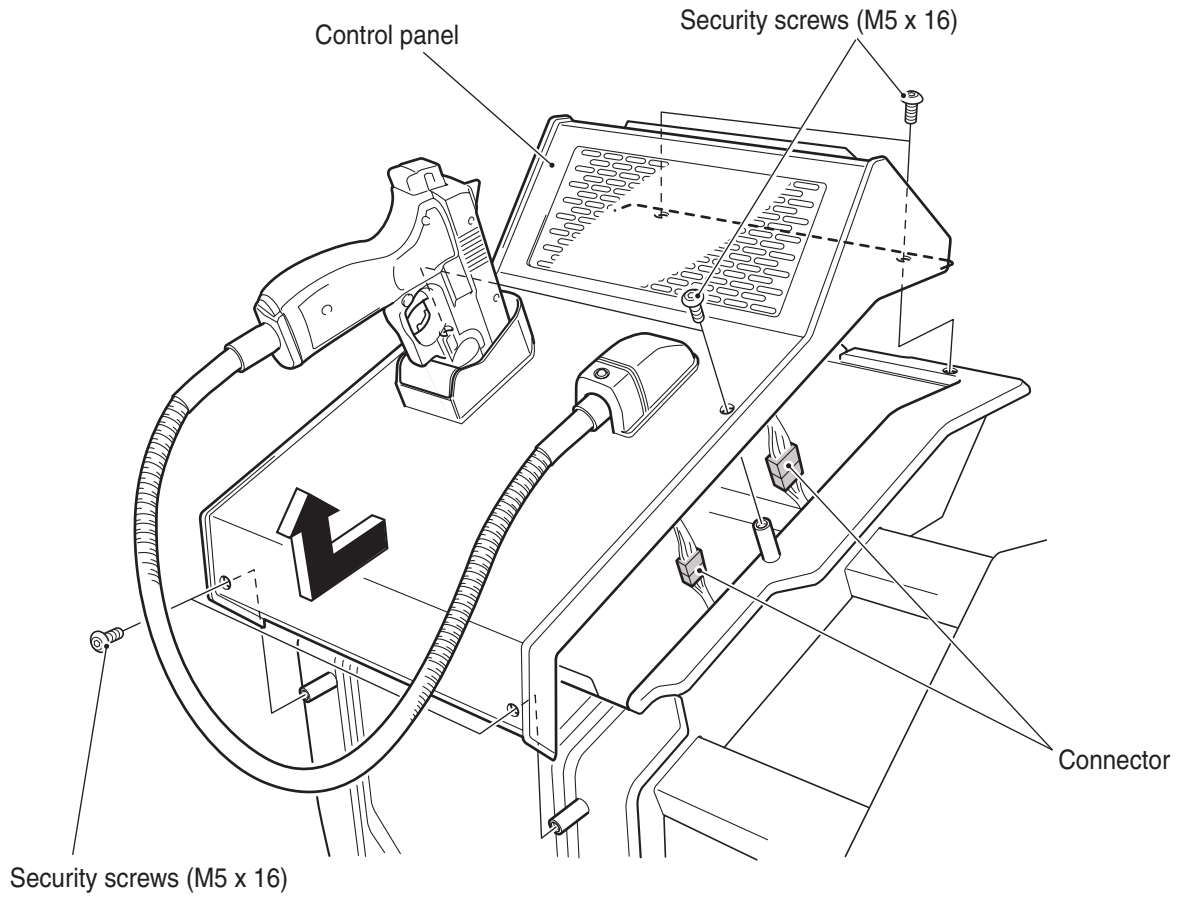

4. Reassemble in reverse order.

7-10 Replacing the SIDELED PC Board

7-10-1 (Control Panel)



- The SIDELED PC Board can be damaged by static electricity. Before handling the SIDELED PC Board, always touch an earthed metal surface to discharge any static electricity.
- The red colour seal is affixed to the SIDELED (R) PC Board's connector. The blue colour seal is affixed to the SIDELED (B) PC Board's connector.

1. Remove the Control Panel. (see 7-9 page 81)
2. Remove 3 off pozi head screws (M3x6), with flat and spring washers, and then remove the SIDELED PC Board.

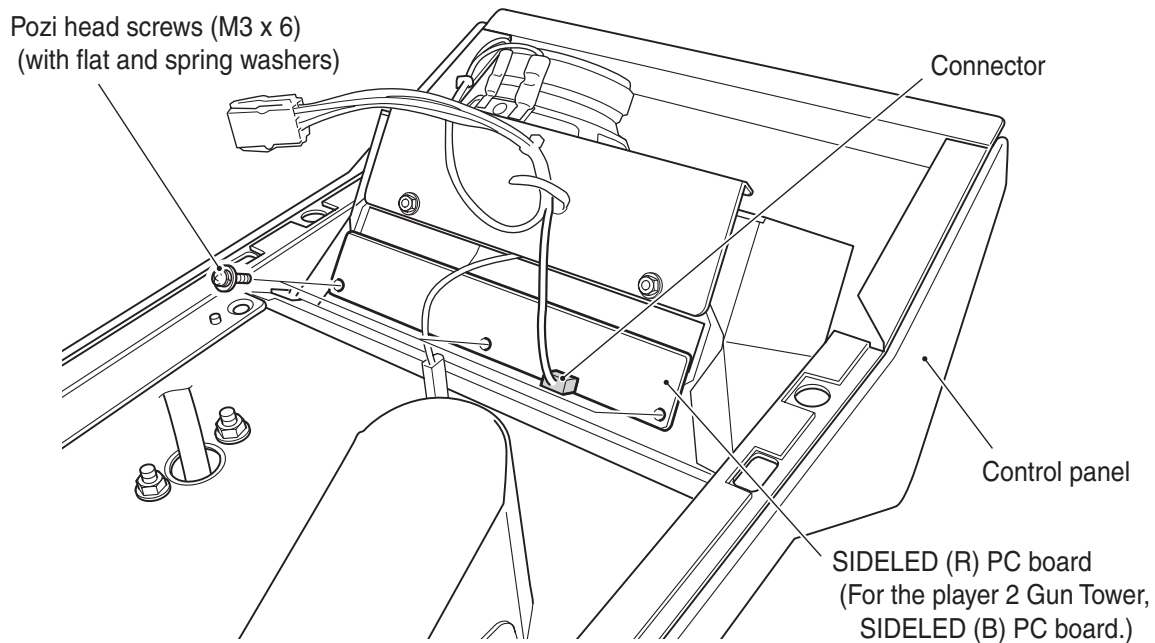

3. Reassemble in reverse order.

7-10-2 (Gun Assy)



- The SIDELED PC Board can be damaged by static electricity. Before handling the SIDELED PC Board, always touch an earthed metal surface to discharge any static electricity.
- The red colour seal is affixed to the SIDELED (R) PC Board's connector. The blue colour seal is affixed to the SIDELED (B) PC Board's connector.

1. Remove the Control Panel. (see 7-9 page 81)
2. Disconnect one connector and remove 2 off cap screws (M4x6). Then remove the Tower LED Bracket.
3. Remove 3 off pozi head screws (M3x6), with flat and spring washers, and remove the SIDELED PC Board.

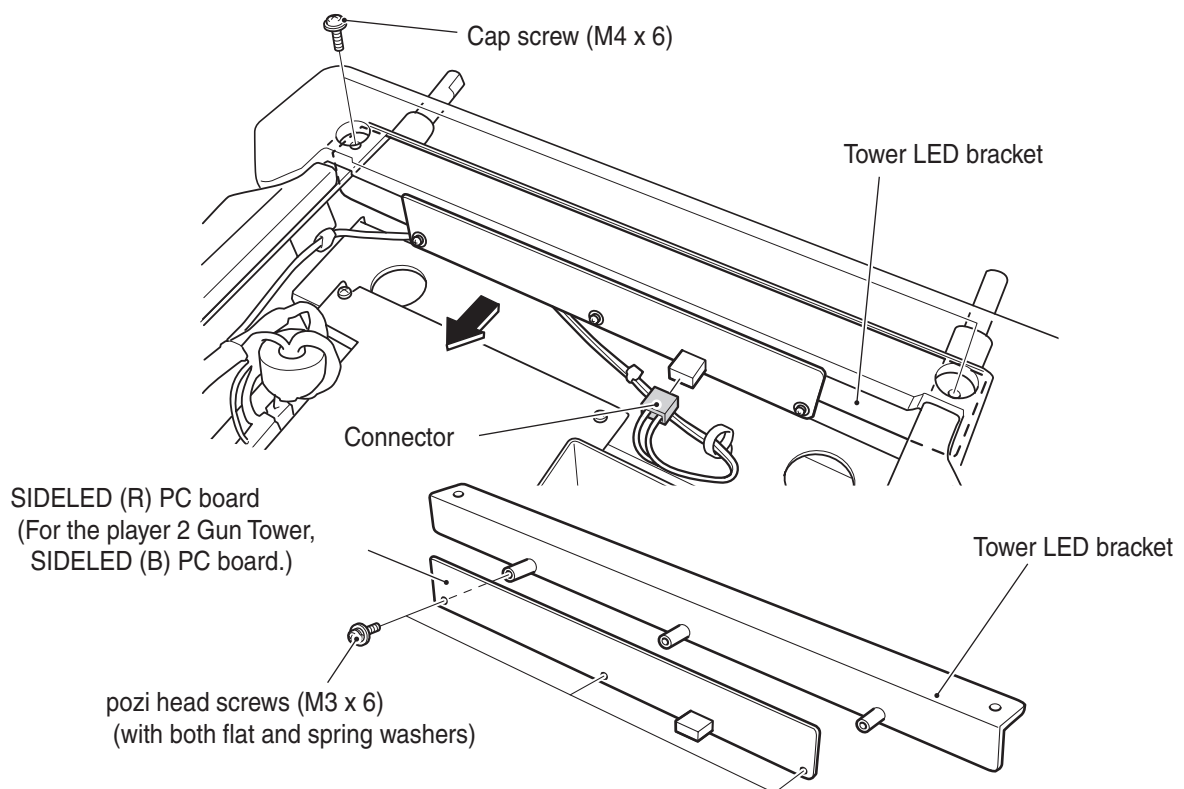

4. Reassemble in reverse order.

7-11 Replacing the NA-JV Board Assy



- **The NA-JV Board can be damaged by static electricity. Before handling the NA-JV Boards, always touch an earthed metal surface to discharge any static electricity.**

1. Remove the Control Panel. (see 7-9 page 81)
2. Disconnect the four connectors and remove 4 off pozi head screws (M4x6). Remove the NA-JV PC Board together with the PCB Base.

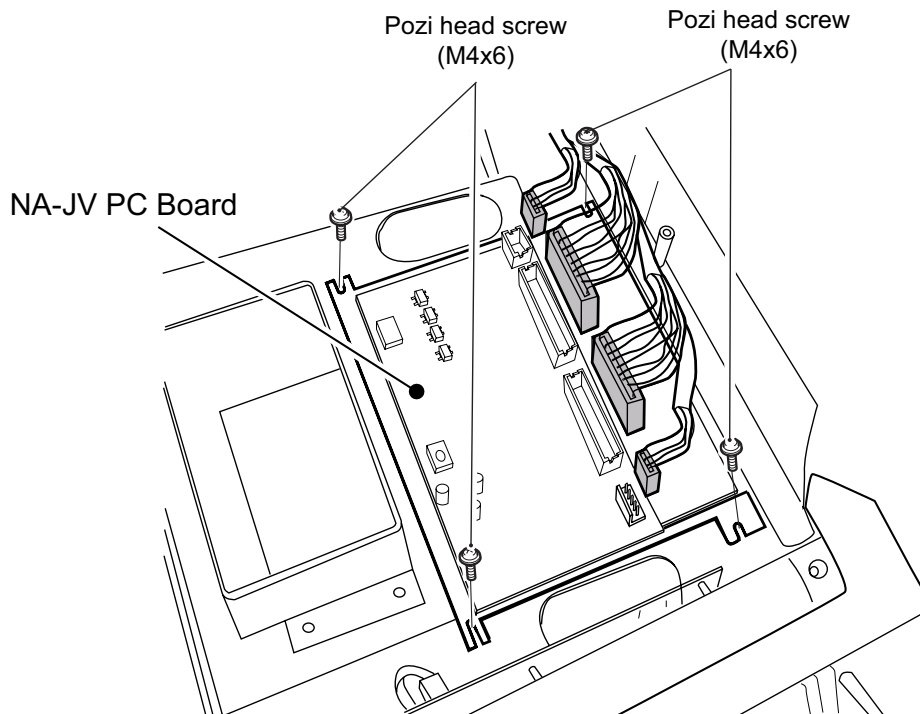

3. Reassemble in reverse order.

Note: After reassembly, check the operation of the NA-JV PC Board. (see 6-2-3-1 page 57)

7-12 Replacing the CPU Board



- **The CPU Board can be damaged by static electricity. Before handling the CPU Board, always touch an earthed metal surface to discharge any static electricity.**

1. Remove the Control Panel. (see 7-9 page 81)
2. Remove the NA-JV PC Board Assy. (see 7-11 page 84)
3. Disconnect the four connectors from the CPUBoard. (For player 2 also remove the Frequency Changeover Connector.)

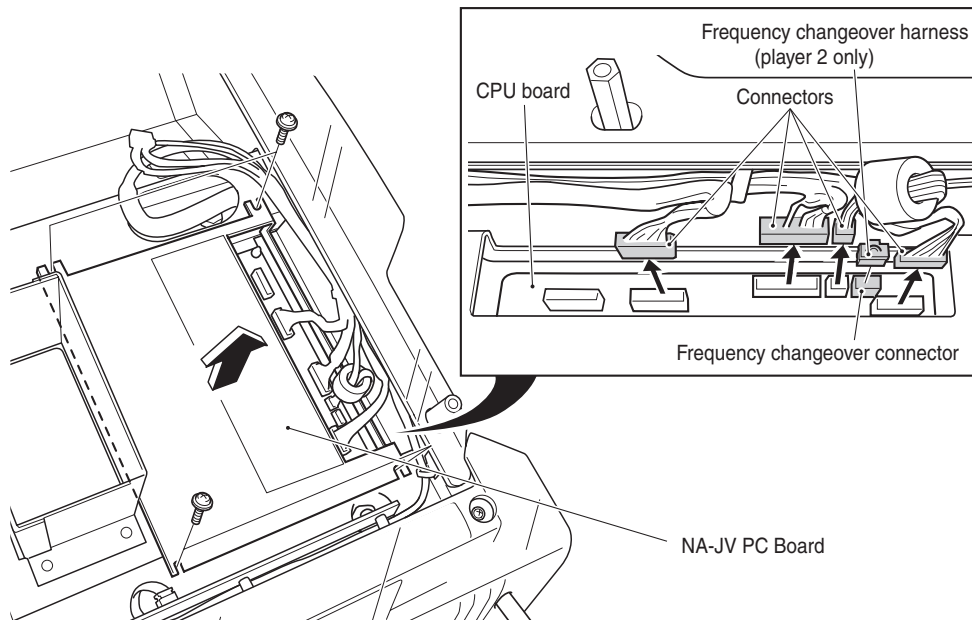

4. Remove 4 off Whizz nut (M3) and remove the CPU Board.

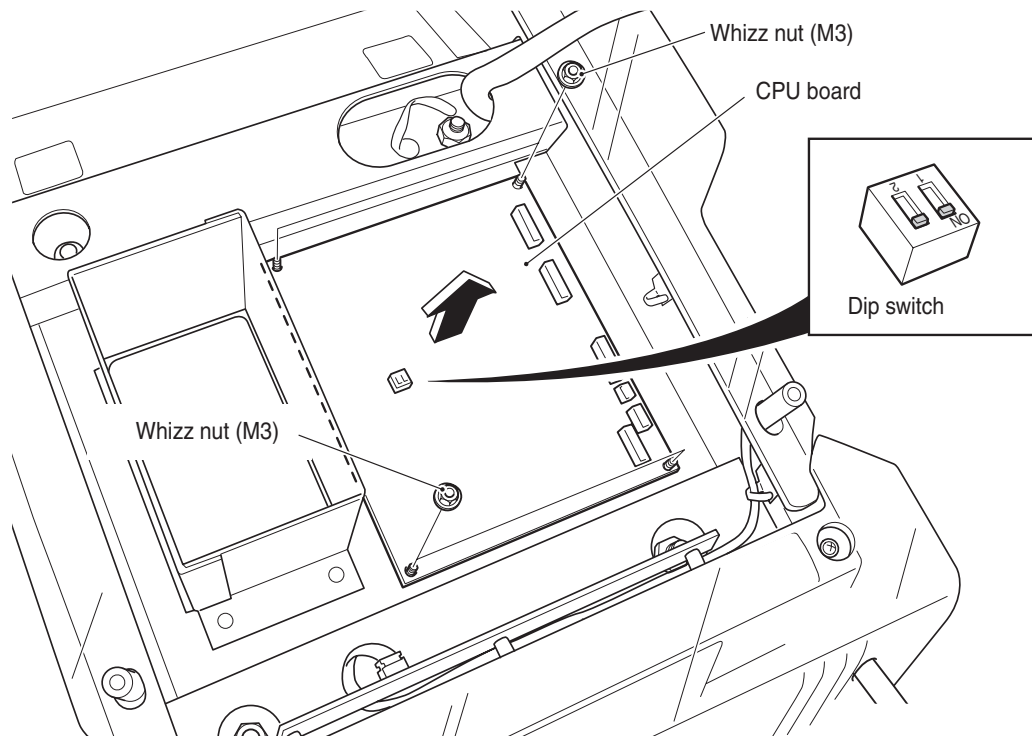

5. Reassemble in reverse order.

- **It is important that the Dip Switches are set correctly for STD and DX versions of this game.**
The settings should be:
STD Sw 1 ON
Sw 2 OFF

DX Sw 1 ON
Sw 2 ON
- **After replacing the CPU Board, be sure to Initialize the Guns.**
(see 6-2-3-2 page 58)
- **If the player 2's CPU Board has been replaced, ensure that the Frequency Changeover Connector has been refitted. If this connector is not fitted, the gun assy detection system may be confused with the player 1 CPU Board and the game will fail to operate correctly.**

7-13 Replacing the Gun Assy

1. Remove the Control Panel ([see 7-9 page 81](#))
2. Remove 2 off whizz nuts (M6) that secure the Gun Assy from the rear of the Control Panel.
3. Pull up and remove the Connector Cover and remove the Gun Assy

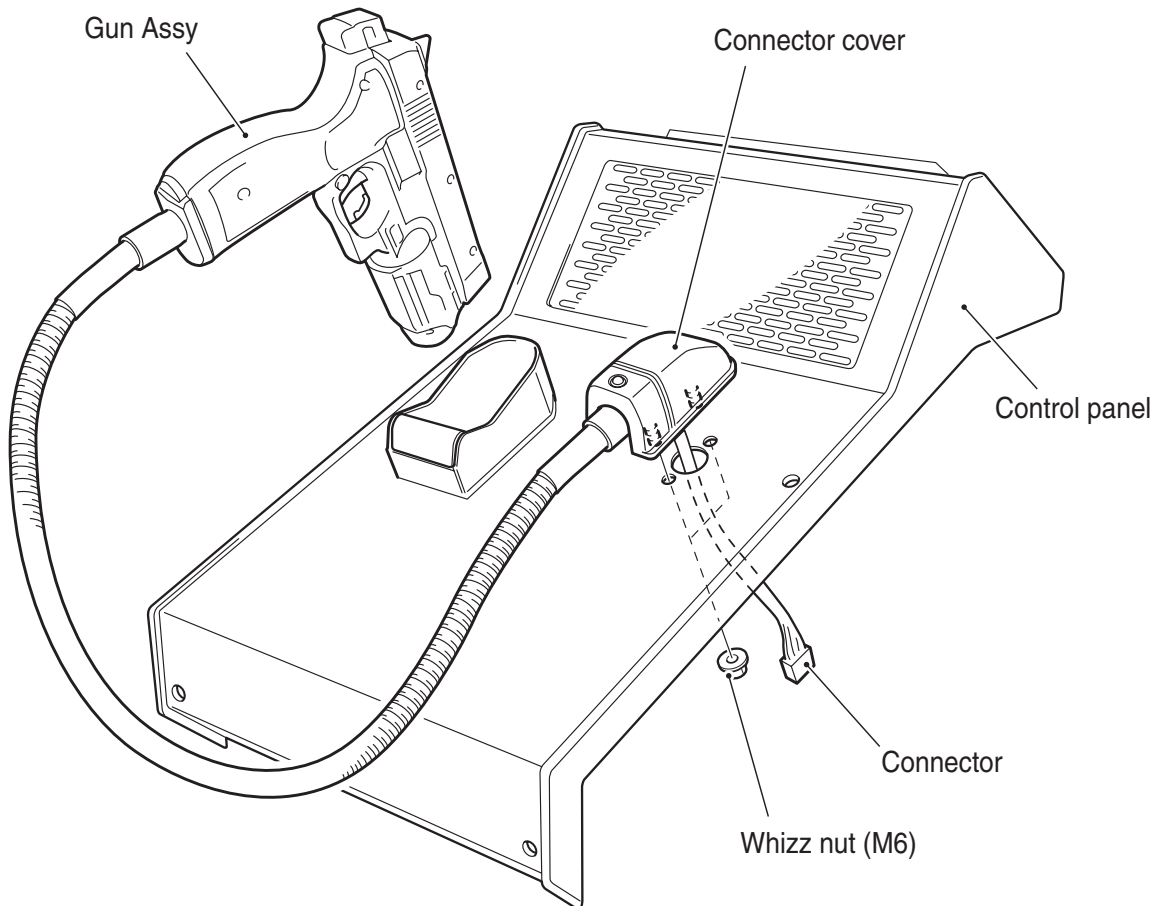

4. Reassemble in reverse order.
- **After replacing the Gun Assy, be sure to Initialize the Guns.** ([see 6-2-3-2 page 58](#))

7-14 Replacing the Gun Slides (L & R)

1. Remove the Gun Assy. (see 7-13 page 87)
2. Remove 5 off button head screws (M3x8) and remove the Slide (L) and Slide (R).

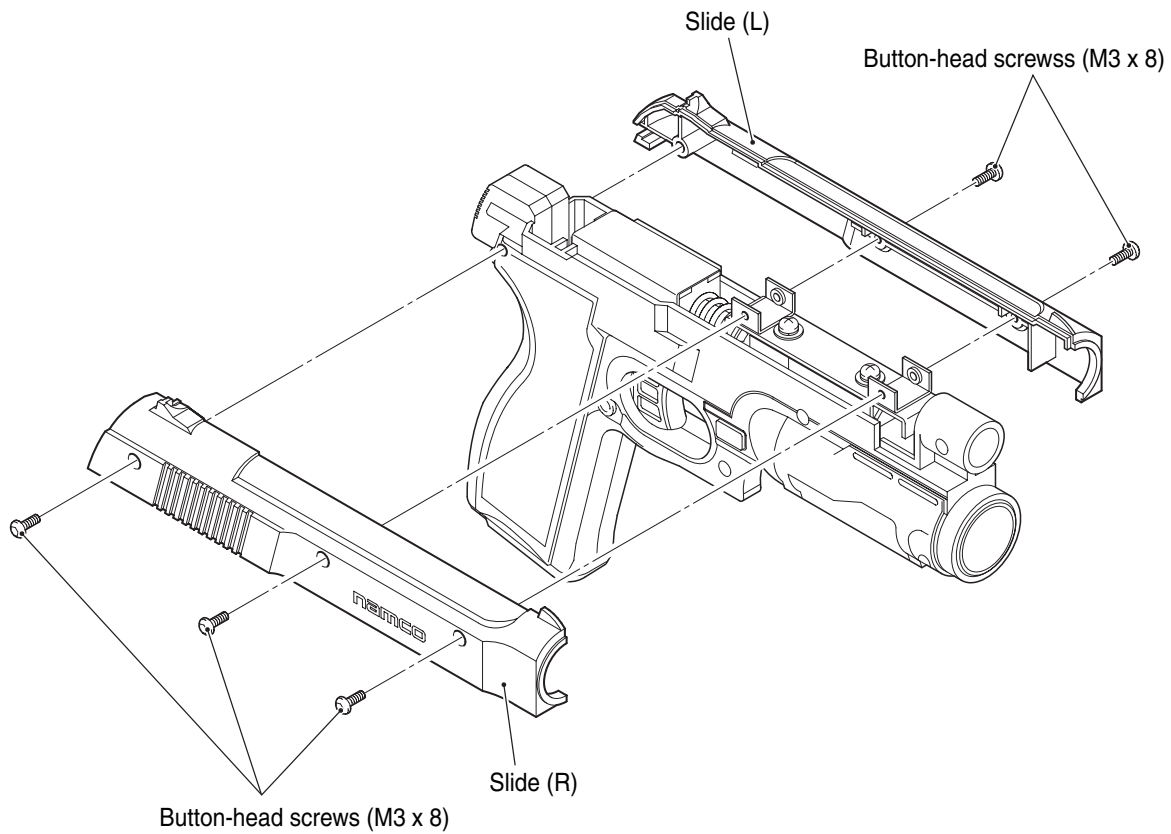

3. Reassemble in reverse order.
- **After replacing the Gun slides, be sure to Initialize the Guns.**
(see 6-2-3-2 page 58)

7-15 Separating The Gun Body

1. Remove the Gun Slides (L & R). (see 7-14 page 88)
2. Lay the Gun Body on it's left side.
3. Remove 6 off button head screws (M3x6) and remove the Gun Body (R).

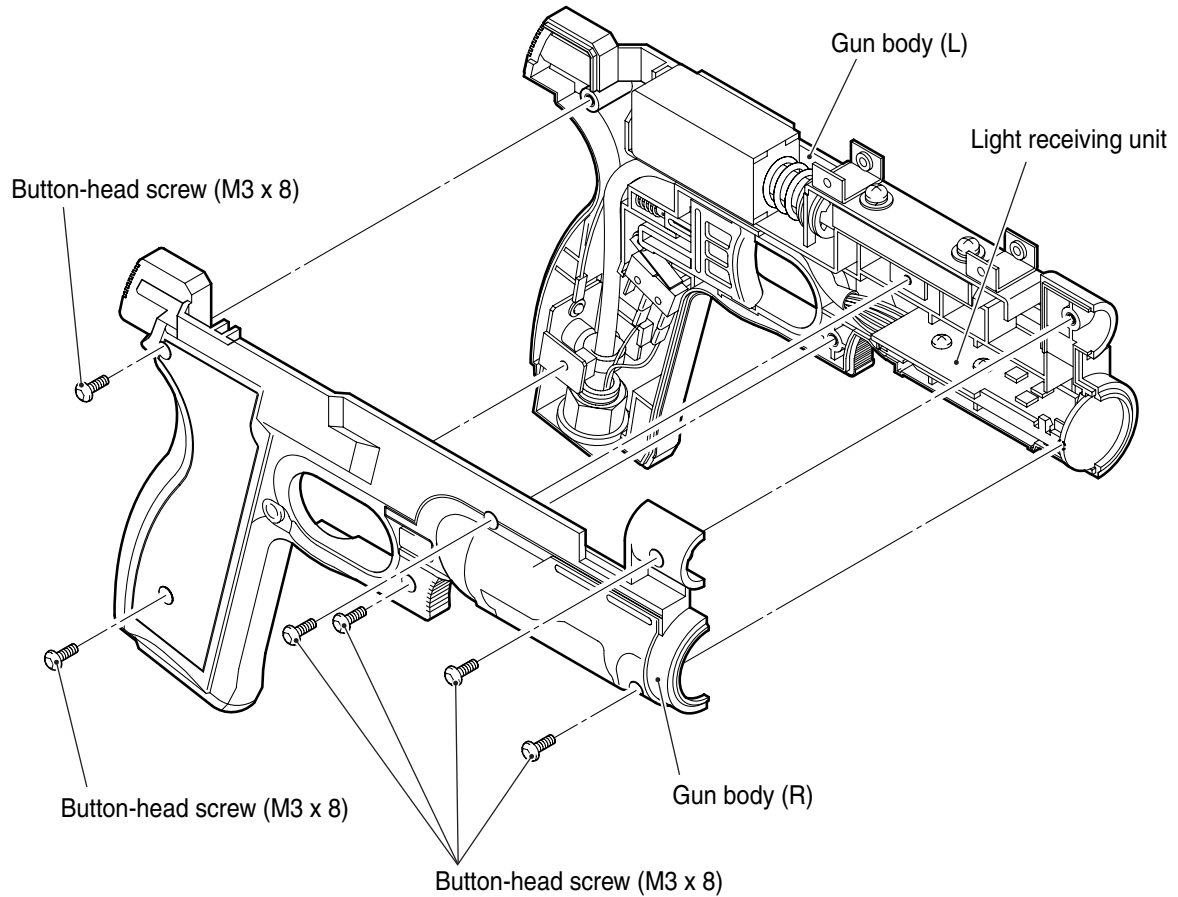

4. Reassemble in reverse order.
- **After replacing the Gun Body, be sure to Initialize the Guns.**
(see 6-2-3-2 page 58)

7-16 Replacing the Gun Light Receiving Unit



- **The Light Receiving Unit can be damaged by static electricity. Before handling the Light Receiving Unit, always touch an earthed metal surface to discharge any static electricity.**
- **Do not disassemble the Light Receiving Unit . Do not touch the knob on the Light Receiving Unit . Any attempt to disassemble the unit or moving the knob can prevent the unit working correctly.**

1. Open the Gun Body. (See 7-15 page 89)
2. Remove the Light Receiving Unit from the indentations in the Gun Body and disconnect the connector to remove the Light Receiving Unit.

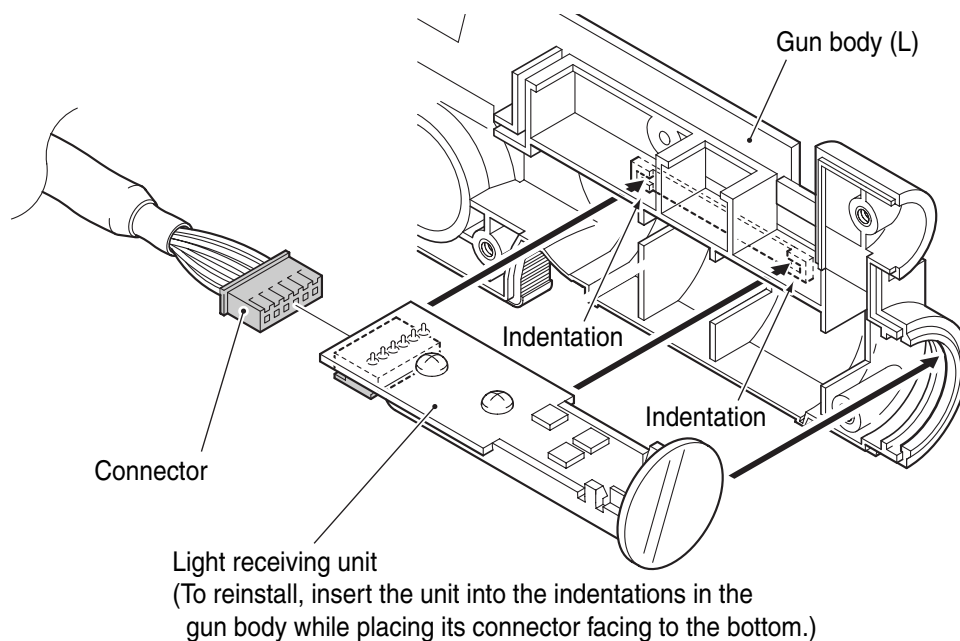

3. Reassemble in reverse order.
- **After replacing the Light Receiving Unit, be sure to Initialize the Guns.** (see 6-2-3-2 page 58)

7-17 Replacing the Gun Solenoid

1. Remove the Gun Body. (see 7-15 page 89)
2. Disconnect the solenoid connector.
3. Remove the button head screw (M3x8) and remove the Solenoid Bracket.
4. Remove the cap screw (M3x5) and remove the Earth terminal and tooth washer (M3).
5. Remove 2 off pozi head screws (M4x6), with flat and spring washers, and remove the Slide Bracket.
6. Remove 4 off cap screws (M3x5) and remove the Solenoid Unit.
7. Remove the Rubber Spacer from the Solenoid Unit. Take care not to lose the spring while removing the Rubber Spacer.

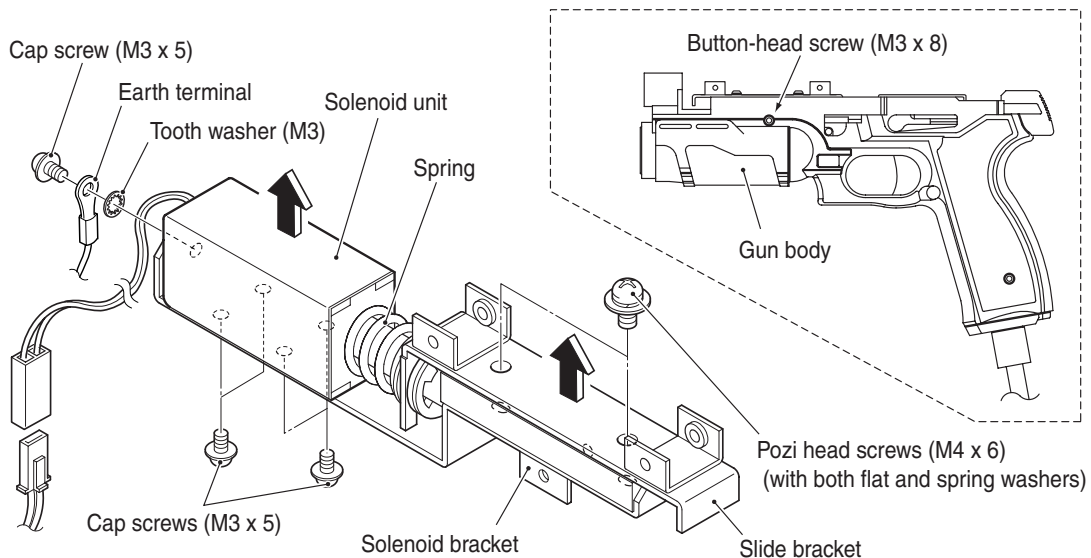

8. Reassemble in reverse order. Pay attention to the installing order of the E-type Stop Ring and Rubber Spacer and the direction of the Spring.

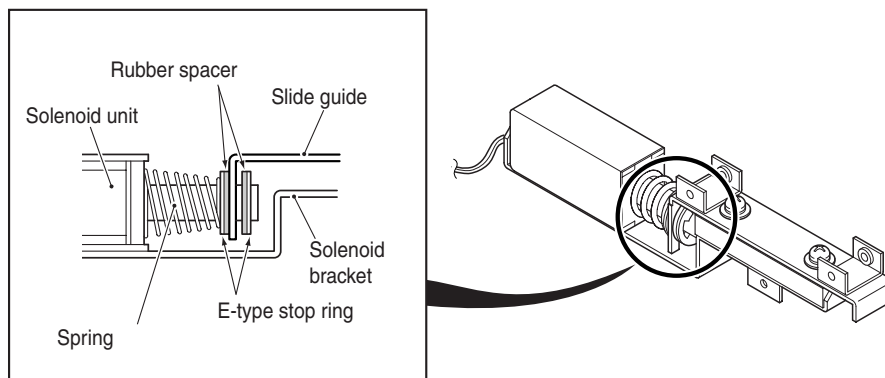

- **After replacing the solenoid Unit, go to Test Mode to check operation.**
(see 6-2-3-4 page 62)
- **Be sure to initialize the Guns.**
(see 6-2-3-2 page 58)

7-18 Replacing the Trigger Microswitch

1. Open the Gun Body. (See 7-15 page 89)
2. Disconnect the two Faston terminals and replace the Microswitch.

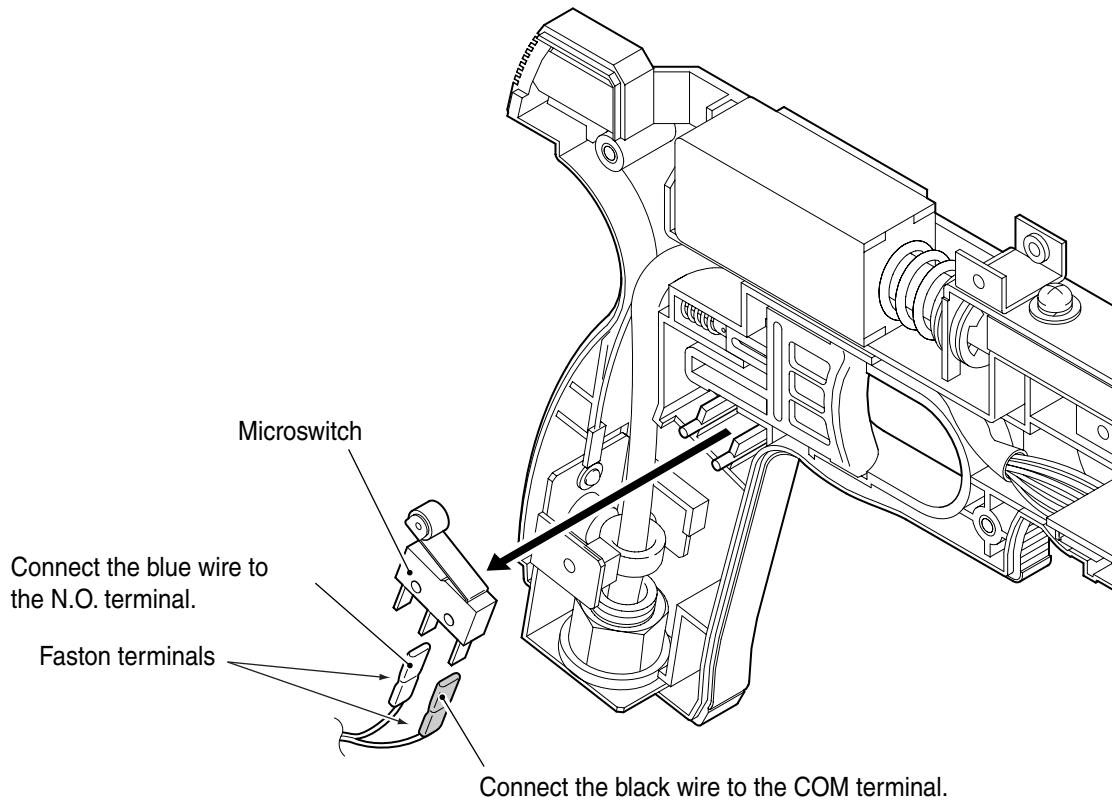

3. Reassemble in reverse order.
 - **After replacing the Microswitch, go to Test Mode to check operation.**
(see 6-2-3-3 page 61)
 - **Be sure to initialize the Guns.**
(see 6-2-3-2 page 58)

7-19 Replacing the Gun Harness

1. Remove the Gun Assy (See 7-13 page 87)
2. Remove the 2 off button head screws (M4x10) and detach the Connector Cover B.
3. Remove the Gun Slides (See 7-14 page 88) and the Gun Body. (See 7-15 page 89)
4. Remove the cap screw (M3x5) and remove the Earth terminal and tooth washer (M3).
5. Disconnect the connectors and remove the two Faston terminals from the microswitch.
6. Remove the button head screw (M3x8) that attaches the Gun Harness to the Gun Body (L), and replace the Gun Harness.

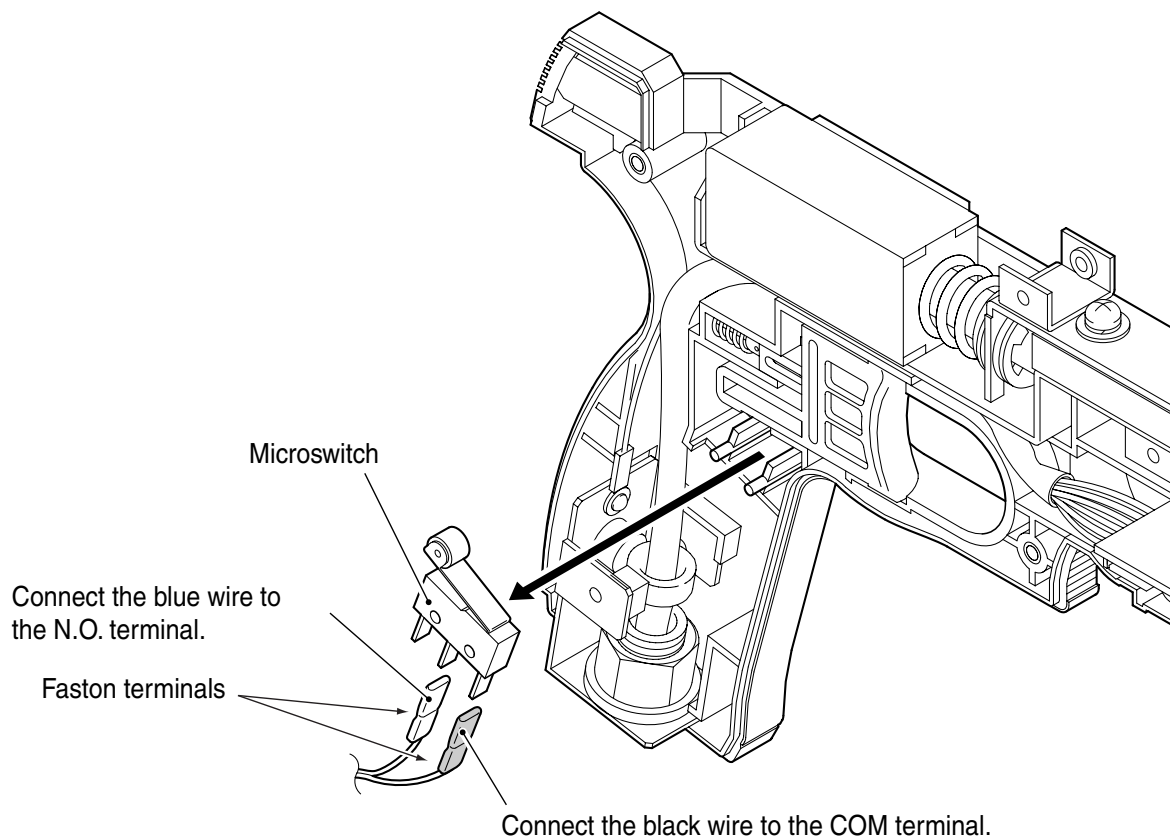

7. Reassemble in reverse order.
- **After replacing the Gun Harness, go to Test Mode to check operation.**
(see 6-2-3-3 page 61)
 - **Be sure to initialize the Guns.**
(see 6-2-3-2 page 58)

7-20 Replacing the Pedal Micro Switch

1. Remove the Pedal Assy from the Coin Tower Assy. (See 7-2-1 page 71).
2. Remove 4 off security screw (M5x12) and remove the Cover M.

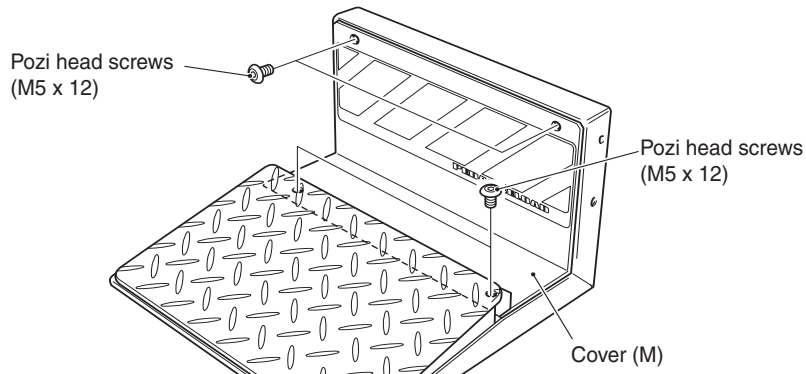

3. Remove 2 off pozi head screw (M3x16) and remove the switch.
When replacing the switch, ensure that the wires are fitted to the correct terminals.

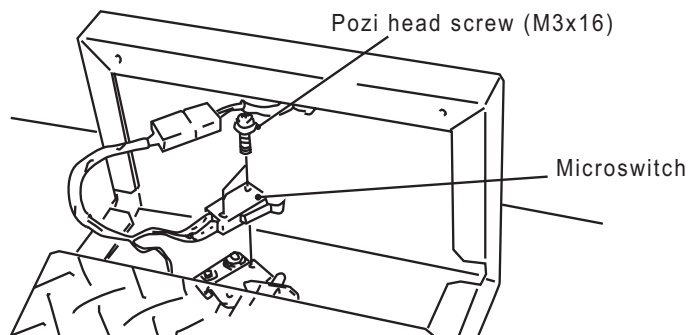

4. Slacken the 2 off whizztite nuts (M4) and adjust the microswitch bracket so that the switch plunger operates the switch correctly without bending the switch lever against the switch body.

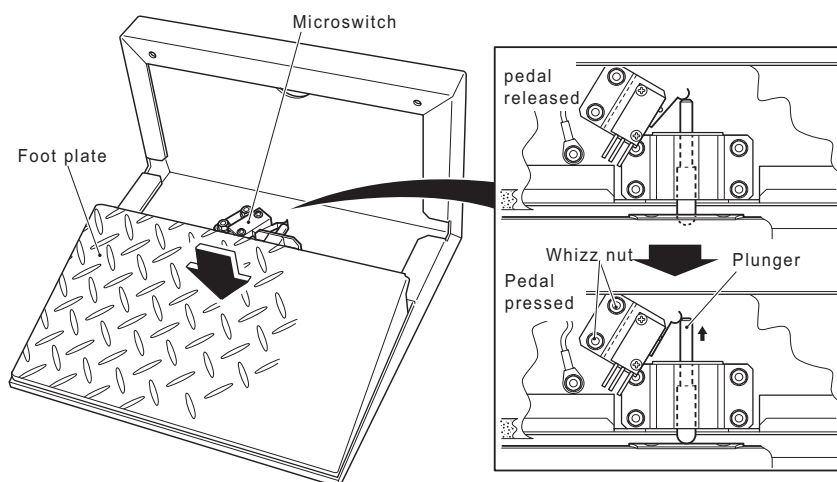

5. Reassemble in reverse order.
 - **After replacing the Micro Switch, go to Test Mode to check operation.**
(see 6-2-3-3 page 61)

7-21 Replacing the Pedal Plunger

1. Remove the Cover (M). (See 7-2-1(2) page 71).
2. Remove the Holder. (See 7-2-1-(3) page 72)
3. Pull out the Plunger from the Holder, and replace the Plunger with a new one. When installing a new plunger, apply light grease to the entire contacting surface between the plunger's holder and plate.

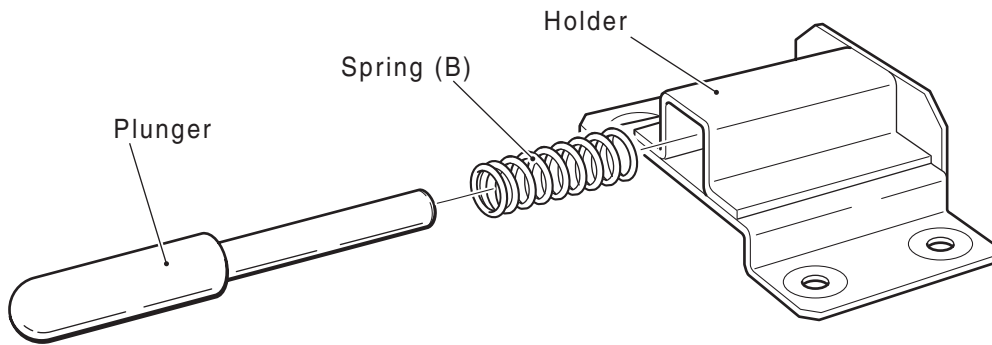

4. Remove old grease from the plate surface on the pedal, and apply new grease.

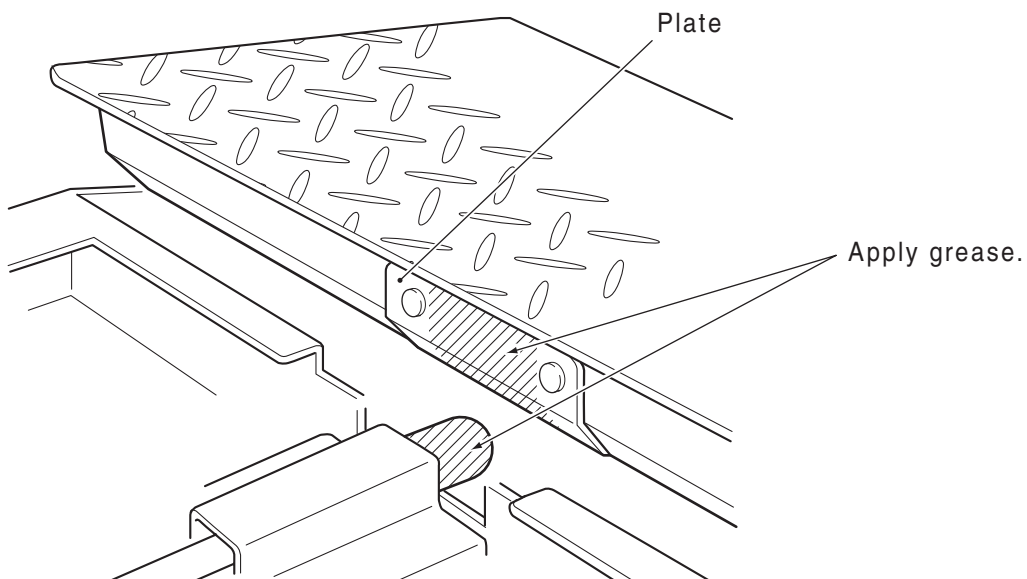

5. Reassemble in reverse order.
- **After replacing the Plunger, go to Test Mode to check operation.**
(see 6-2-3-3 page 61)

7-22 Removing the Monitor



This symbol indicates that a part must not be touched.

WARNING

- To ensure the safety of staff and other people from possible electric shock, accident or injury, and to prevent damage to the electrical circuits of the machine, **always turn the power to the OFF** before commencing this work.
- Some internal parts of the monitor are charged with 20,000volts or higher. To prevent possible electric shock, do not touch any internal parts of the monitor.
- The anode cap, anode lead, and H.T. transformer retain high voltage even after the power has been turned off. **Never** touch these parts by hand.
- When replacing the monitor, do not touch parts other than the stay, frame and monitor tube surface.

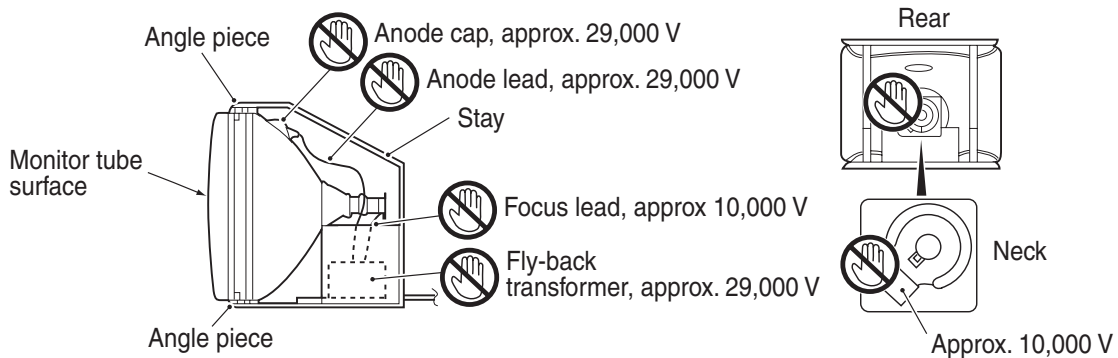

- The monitor circuitry consists of the primary and secondary sides, and they are electrically insulated from each other. Do not touch the primary side, or touch (short circuit) the primary side and secondary side simultaneously. Doing so can result in electric shock or machine malfunction.

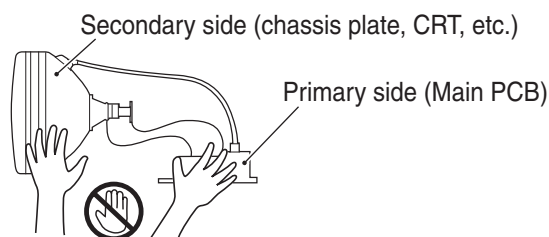

- If any foreign material enters the monitor, turn the power off to prevent possible fire or monitor malfunction.
- If the monitor generates an abnormality, turn the power off immediately and contact your distributor.
- The monitor weighs approx.42kg. It must be handled by at least two persons.

1. Remove 4 off pozi wood screws (No 6) and remove the Monitor Rear Panel.
2. Disconnect the power and video connectors from the monitor.

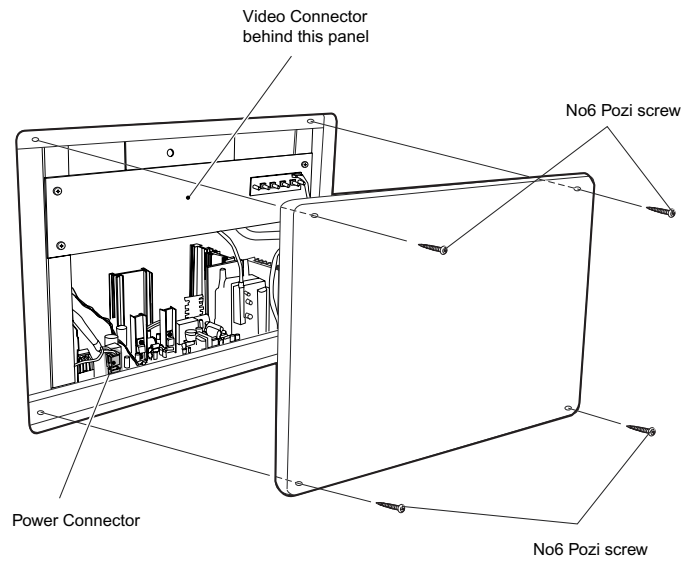

3. Remove the Monitor Mask. ([see 7-3 page 74](#))
4. Remove 4 off pozihead screws (with flat and spring washers) and 4 off flat washers (M10).
5. Withdraw the monitor by tilting it forward at the top and withdrawing it from the front of the cabinet.

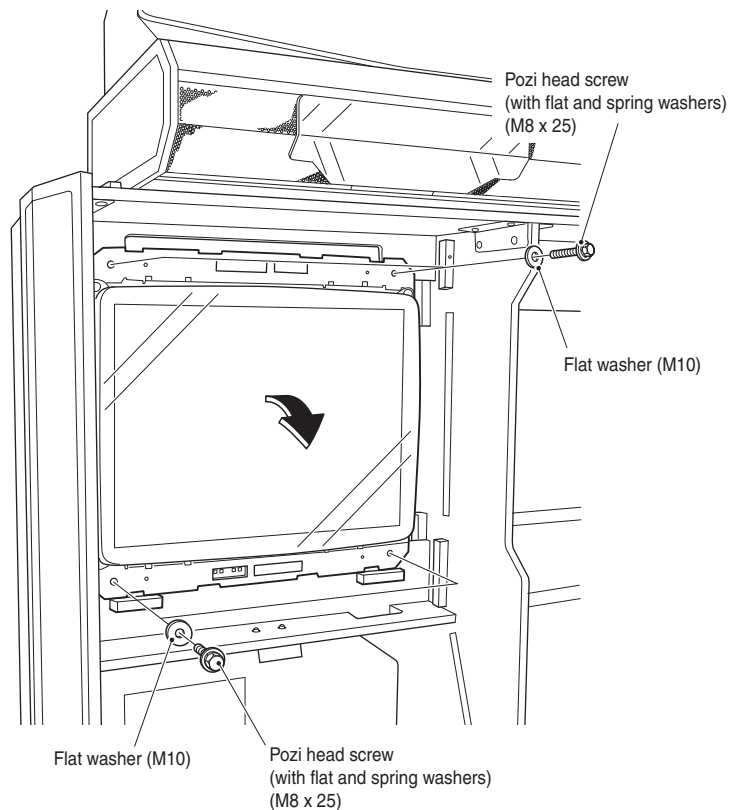

6. Reassemble in reverse.

8. TROUBLESHOOTING

8-1 Monitor Cabinet Assy

Symptom	Usual Cause	Action
No image is displayed on the monitor	Badly connected connector	Check all connectors
	The Monitor is defective	Replace the Monitor
	The Game PCB Assy is defective	Replace the Game PCB Assy
There is no sound from the speakers	The Volume level is too low	Adjust the volume setting
	Badly connected connector	Check all connectors
	The AMP PC Board is defective	Replace the AMP PC Board
	The Game PC Board Assy is defective	Replace the Game PC Board Assy
The SIDELED PC not lighting	Badly connected connector	Check all connectors
	The SIDELED PC Board is defective	Replace the SIDELED PC Board
	The NA-JV PC Board is defective	Replace the NA-JV board

8-2 Header Assy

Symptom	Usual Cause	Action
The fluorescent lamp does not light	Poor connection	Check all connectors
	The fluorescent lamp is burnt out	Replace the fluorescent lamp
	The starter is burnt out	Replace the starter

8-3 Pedal Assy

Symptom	Usual Cause	Action
The pedal does not operate properly	Poor connection	Check all connectors
	The Micro Switch is defective	Replace the Micro Switch
	The plunger is worn out	Replace the plunger
	The NA-JV PC board is defective	Replace the NA-JV PC board

8-4 Control Assy

Symptom	Usual Cause	Action
The SIDELED PC board is not lit. (Inside the Control Panel, Inside the Gun Tower)	Badly connected connector	Check all connectors
	The SIDELED PC Board is defective	Replace the SIDELED PC Board
	The NA-JV PC Board is defective	Replace the NA-JV board
There is no sound from the speakers	The Volume level is too low	Adjust the volume setting
	Badly connected connector	Check all connectors
	The AMP PC Board is defective	Replace the AMP PC Board
	The Game PC Board Assy is defective	Replace the Game PC Board Assy

8-5 Gun Assy

Symptom	Usual Cause	Action
The gun does not shoot correctly	The gun sight is out of adjustment	Adjust the gun sight
	The tip of the gun barrel is dirty	Clean
	The filter is dirty	Clean
	The tip of the gun is positioned too close to the screen	Keep the gun away from the screen (more than 60cm between gun tip and screen)
	The same machines are next to each other	Connect the frequency changeover harness correctly
	A poor connection	Check all connectors
	The LED board is defective	Replace the defective LED board
	The light receiving unit is defective	Replace the light receiving unit
	The CPU board is defective	Replace the CPU board
	The NA-JV PC board is defective	Replace the NA-JV PC board
The trigger does not work	A poor connection	Check all connectors
	The micro-switch is defective	Replace the micro-switch
	The NA-JV PC board is defective	Replace the NA-JV PC board
The gun does not recoil	A poor connection	Check all connectors
	The solenoid is defective	Replace the solenoid
	The NA-JV PC board is defective	Replace the NA-JV PC board

9. PARTS

9-1 Monitor Cabinet

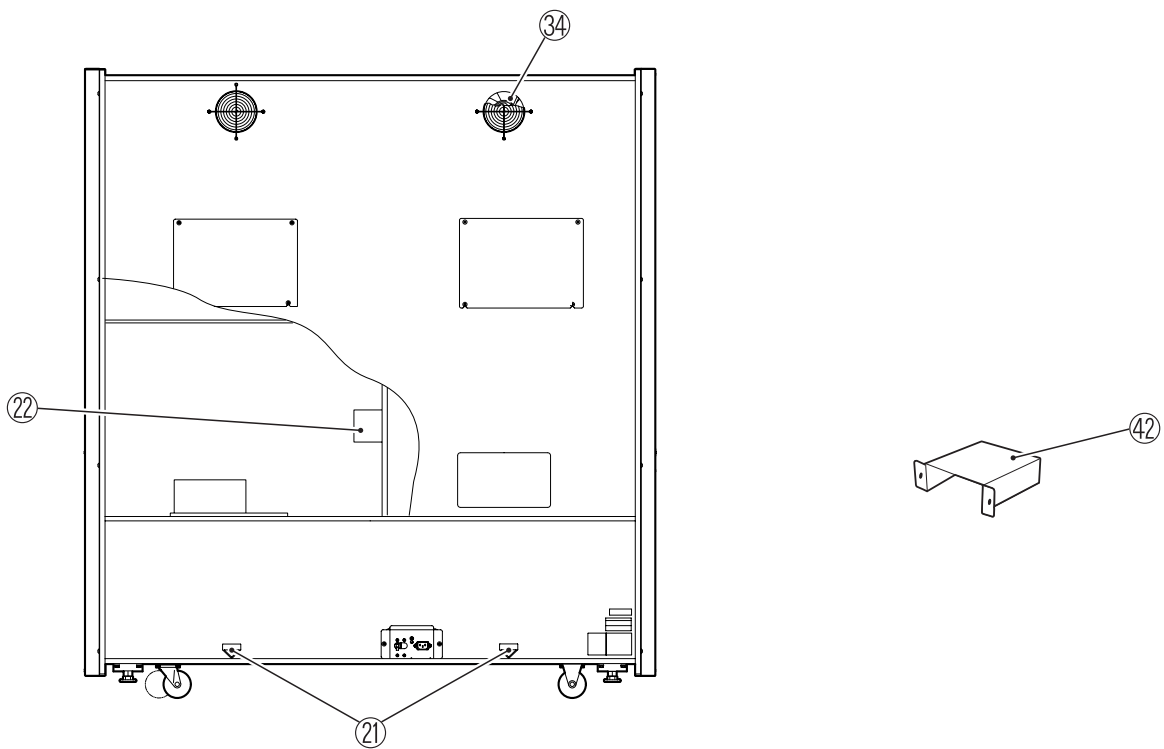
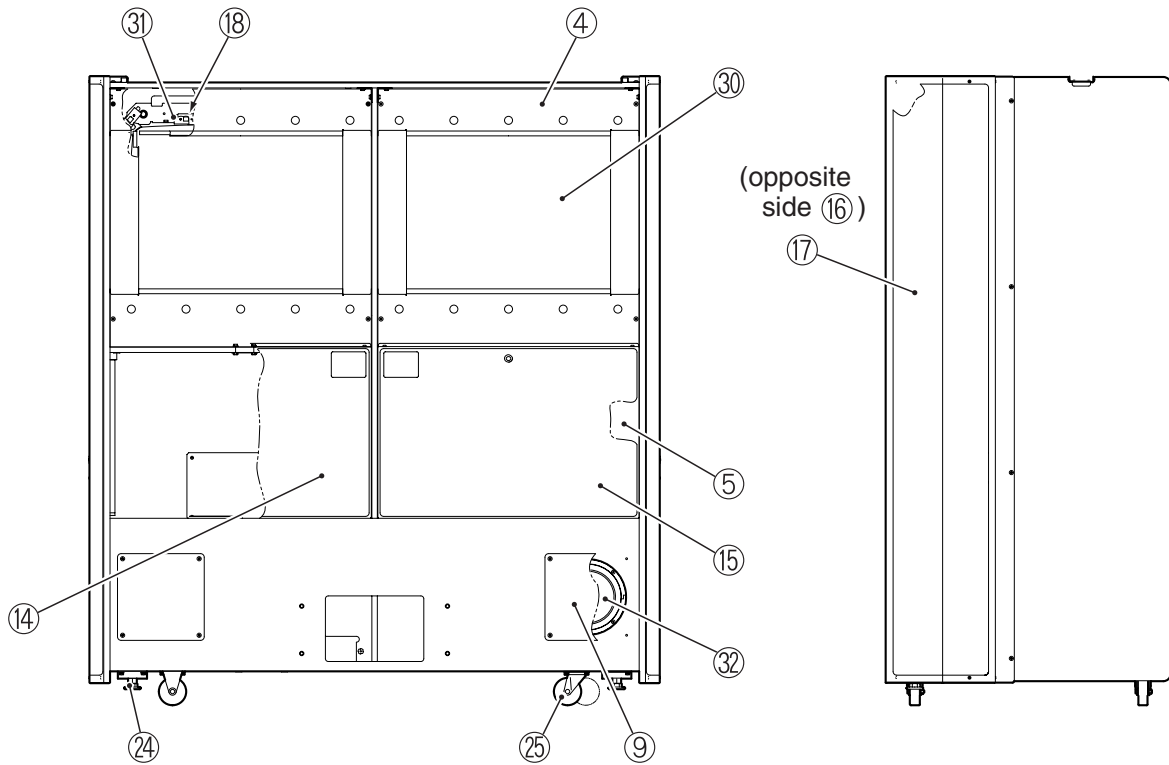

Item	Description	Part No
4	Monitor Mask	XTC4-NTC41505
5	Front Panel	XTC4-NTC41502
9	Bass Speaker Grille	XTC4-NTC41204
14	Front Cover Decal (L)	40000858
15	Front Cover Decal(R)	40000859
16	Outer Side Decal (L)	40000856
17	Outer Side Decal (R)	40000857
21	"Fork Here" Decal	40000072
22	SwitchMode Power Supply	83000030
24	Adjustable Foot (M16x95)	88300079
25	Swivel Castor - 75mm	5900005
30	Monitor - 29" Flat Screen - Patranic	84000129
31	LED Board - 306-747	XTC4-LEDPCB
32	Bass Speaker - FAD205GA2713	XTC4-BASSSPEAKER
34	Fan 4¼" 230v	67000015
42	SD Harness Cover	XTC4-NTC41021-1

9-2 Speaker Box Assy

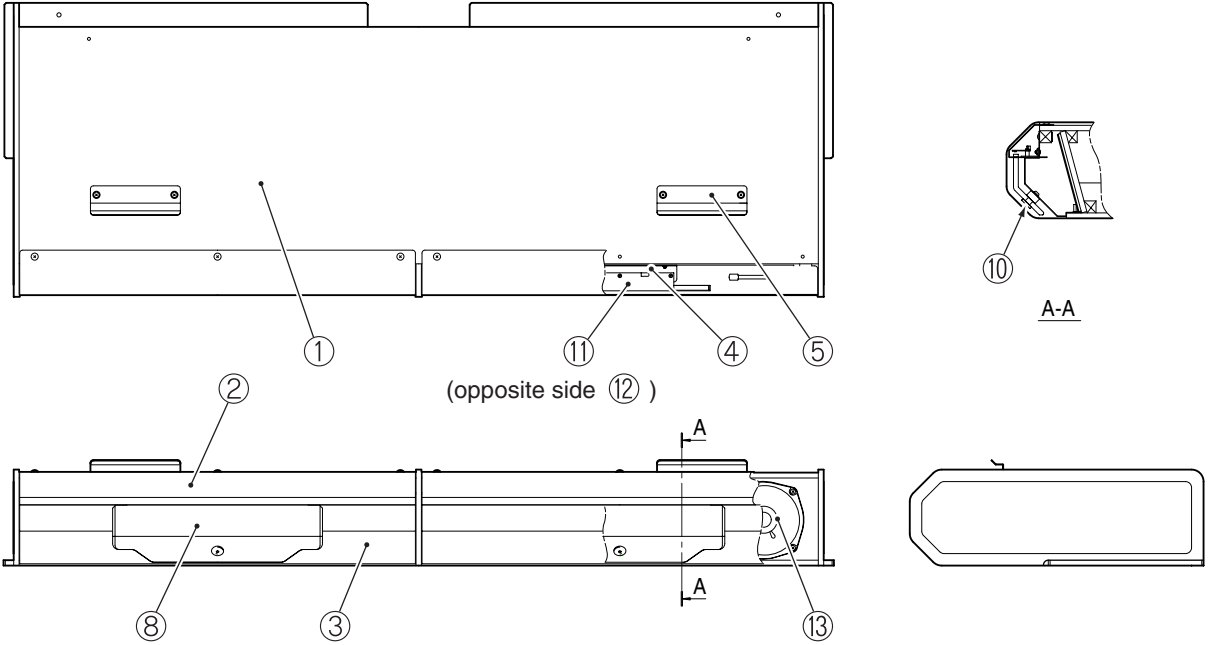

Item	Description	Part No
2	Top Bracket	XTC4-NTC41602-1
3	SD Speaker Grille	XTC4-NTC41601-1
4	LED Bracket	XTC4-NTC41303-1
5	Header Bracket	XTC4-NTC41304-2
8	Header LED Acrylic	30000102
10	Countersunk Mounting Washer	
11	SIDELED (B) PC Board	XTC4-SIDELEDB
12	SIDELED (R) PC Board	XTC4-SIDELEDR
13	Speaker	62000163

9-3 Header Assy

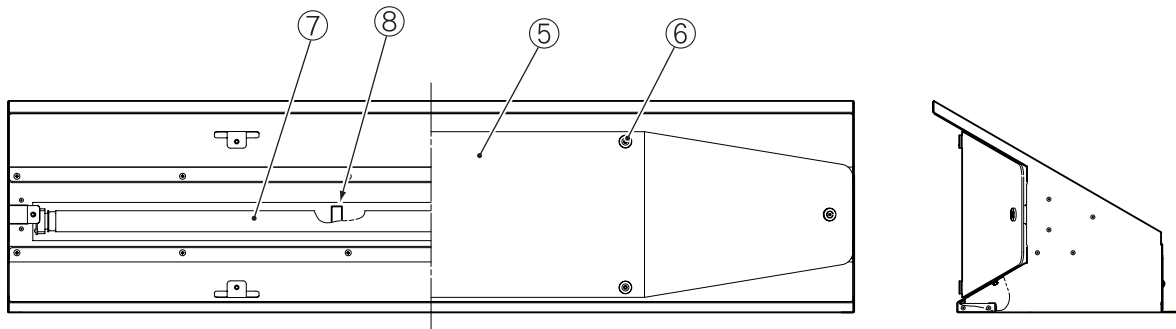

Item	Description	Part No
5	Top Header Acrylic	30000103
6	Countersunk Mounting Washer	
7	Fluorescent Lamp 4ft	64500039
8	Starter	63000000

9-4 Game PCB Assy

(⑥ Detailed diagram of PCB tray)

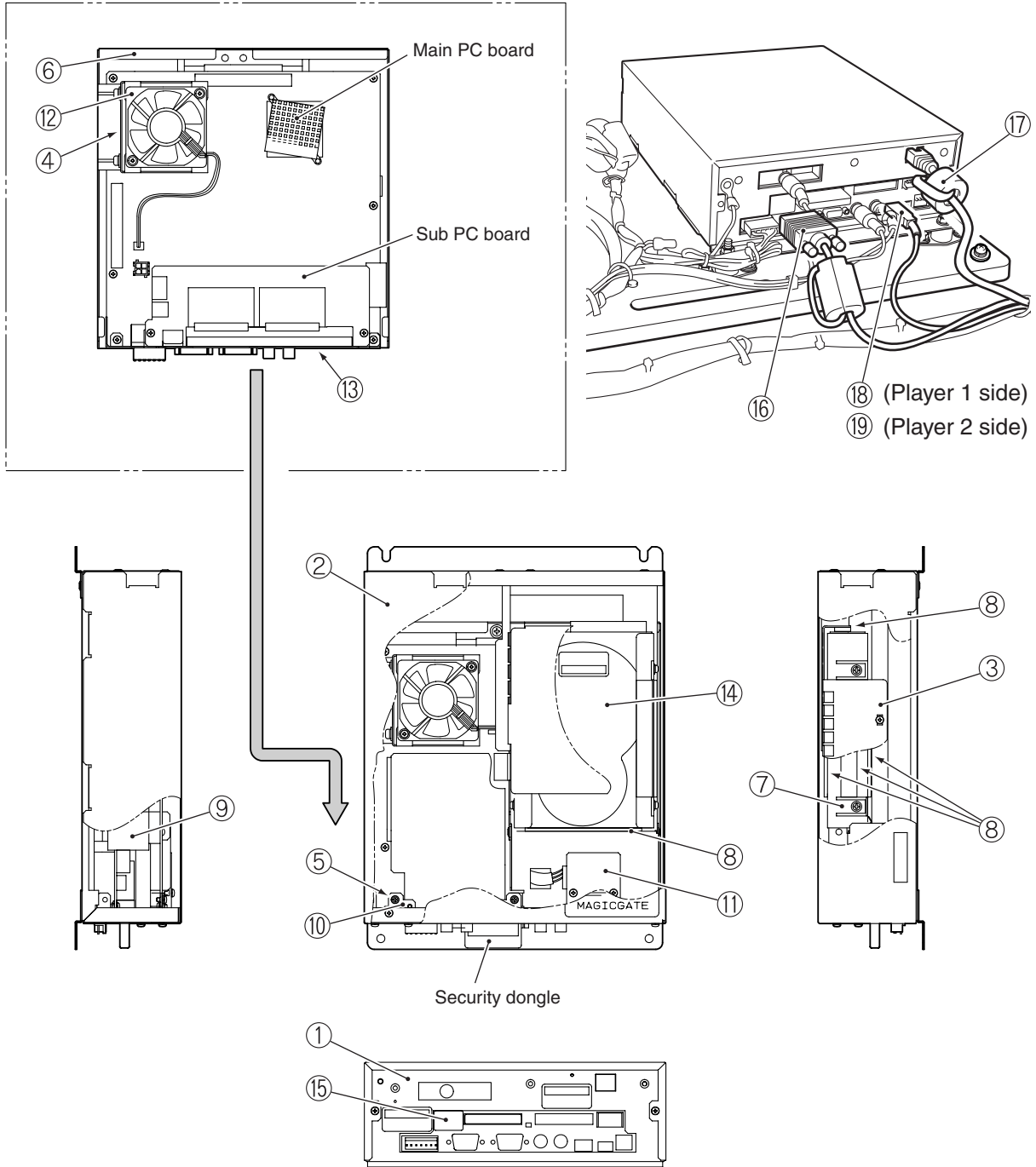

Item	Description	Part No
1	Case	XTC4-463-098
2	Cover	XTC4-463-092
3	HDD Mount Bracket	XTC4-463-093
4	Fan Bracket	XTC4-463-094
5	EX PCB Stay	XTC4-463-095
6	PCB Tray	XTC4-463-097
7	HDD Bracket	XTC4-463-096
8	Cushion (L)	XTC4-463-097
9	RISER PCB	XTC4-306-758
10	EXSOUND PCB	XTC4-306-759
11	UE PCB	XTC4-306-736
12	Fan Motor	XTC4-845-939
13	PCB Stay	XTC4-463-088
14	HDD	XTC4-306-760
15	USB Cover	XTC4-463-090
16	Video Cable	XTC4-007-350
17	LAN Cable (STP straight)	XTC4-007-301
18	USB-XA5P Cable	XTC4-007-348
19	USB-XA6P Cable	XTC4-007-349

9-5 Control Assy

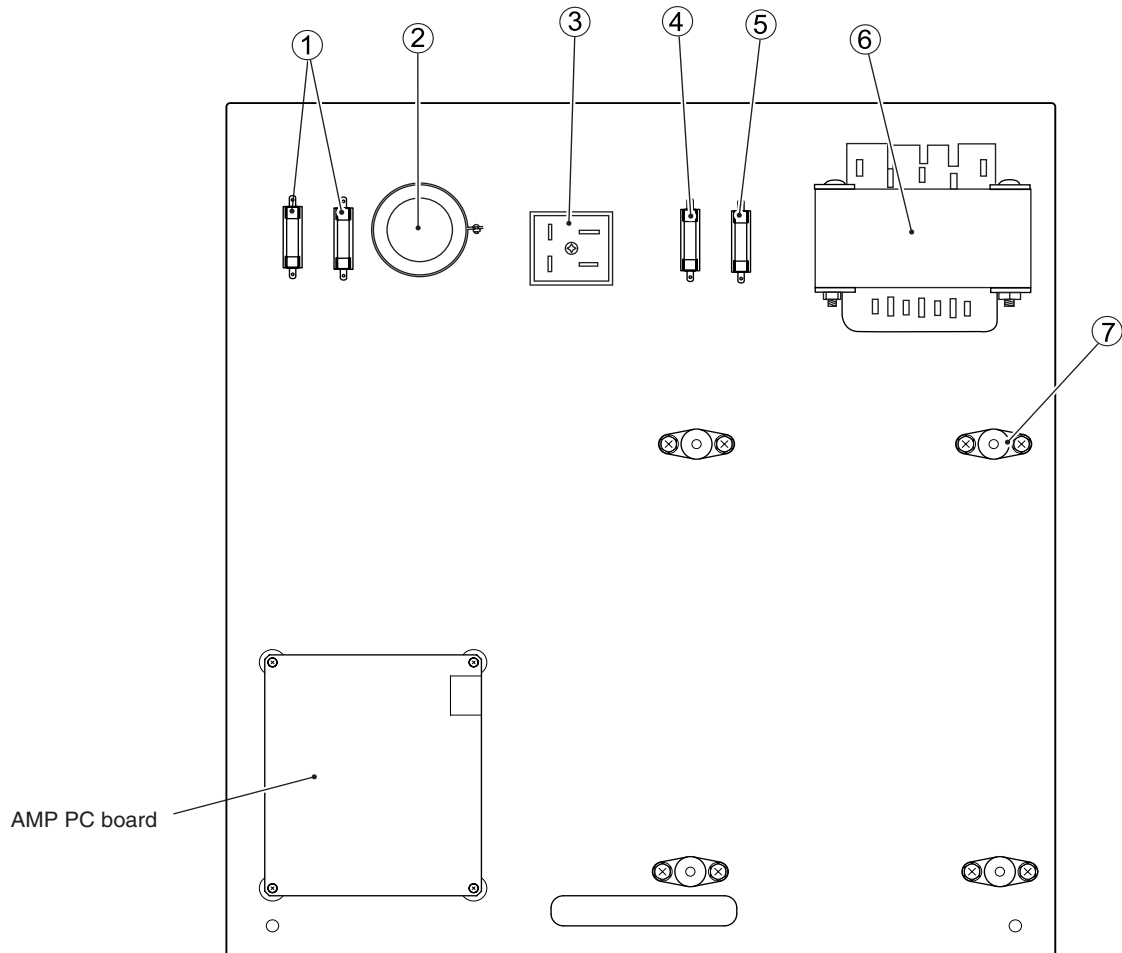

Item	Description	Part No
1	500mA 1¼" A/S Fuse	63500637
2	Capacitor 22,000µF 25V	70200043
3	Bridge Rectifier	71000041
4	2A 1¼" Quick-Blo Fuse	63500604
5	1A 1¼" Quick-Blo Fuse	63500424
6	Transformer 18V @ 3A	67700015
7	Round Shape Vibration-Isolation Rubber - KB-20	XTC4-NT4DX11P15x12

9-6 Service Bracket Assy

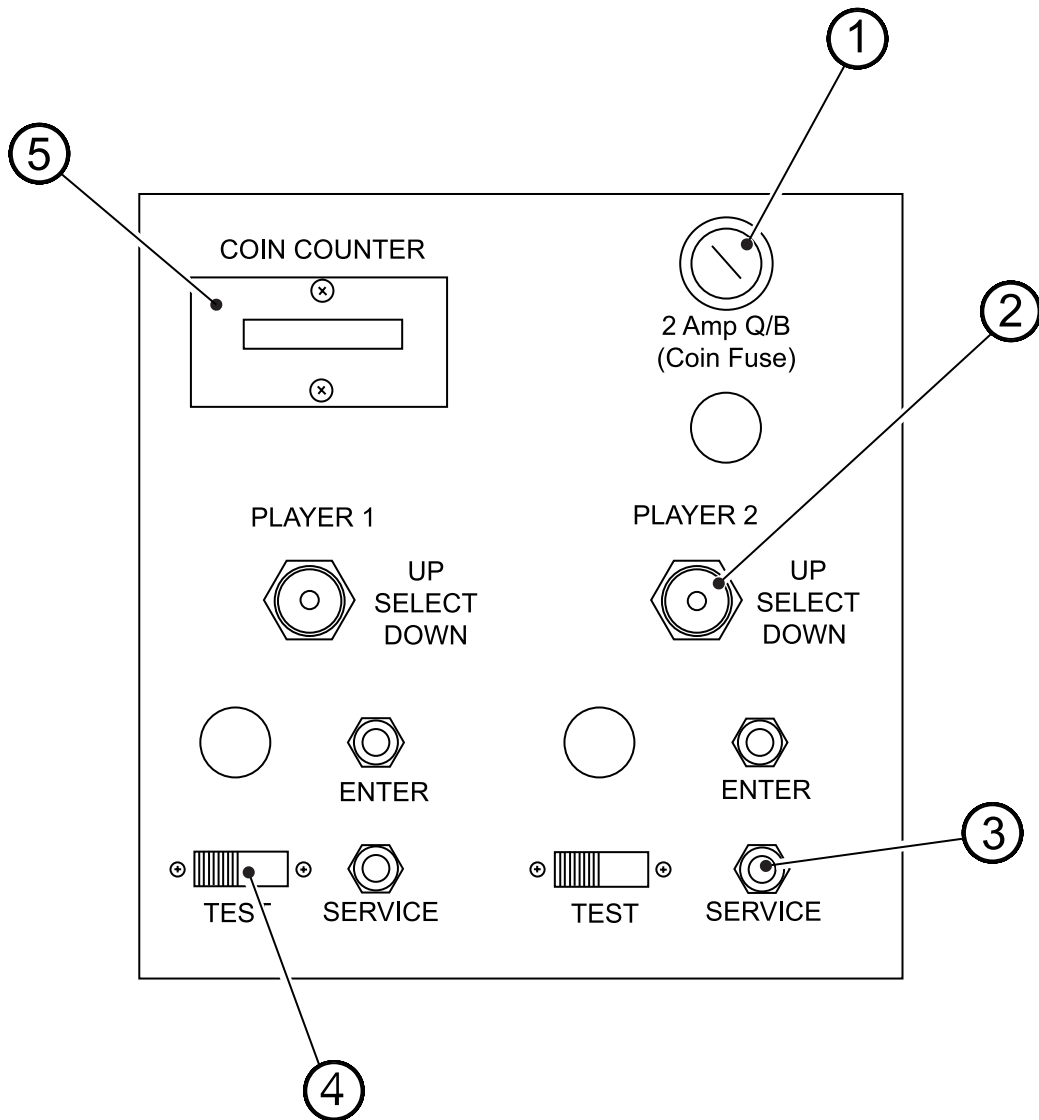

Item	Description	Part No
1	Fuseholder 20mm Panel Mount	63500786
	Fuse 20mm 2A Q/B	63500501
2	SPDT Toggle Switch - (momentary action)	60000010
3	Pushbutton Switch - 7mm Red F424	60000059
4	Miniature Slide Switch	60000023
5	Panel Meter - 3.4~6v	65000002

9-7 Coin Tower Assy

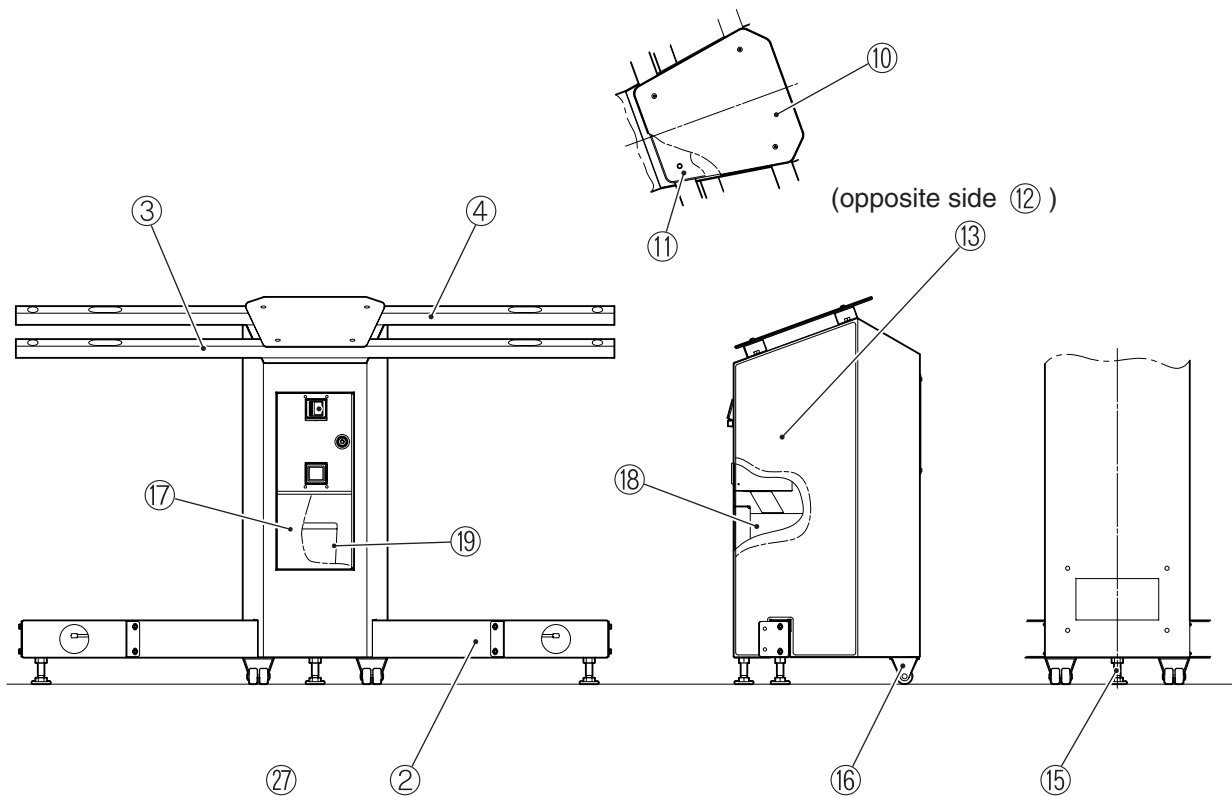

Item	Description	Part No
2	Gun Console Lower Cross Member	XTC4-NTC1102-1
3	Gun Console Upper Cross Member Front	XTC4-NTC1103-2
4	Gun Console Upper Cross Member Rear	XTC4-NTC1104-1
10	Metal Instruction Panel	XTC4-NTC3101-1
11	Acrylic Instruction Panel	30000110
12	Coin Tower Side Decal L	40000852
13	Coin Tower Side Decal R	40000853
15	Adjustable Foot (M16x95)	88300079
16	Swivel Castor - 38mm	59000003
17	SecurDoor	53100351
18	Under Box	47000203
19	Cash Box	39000066

9-8 Pedal Assy

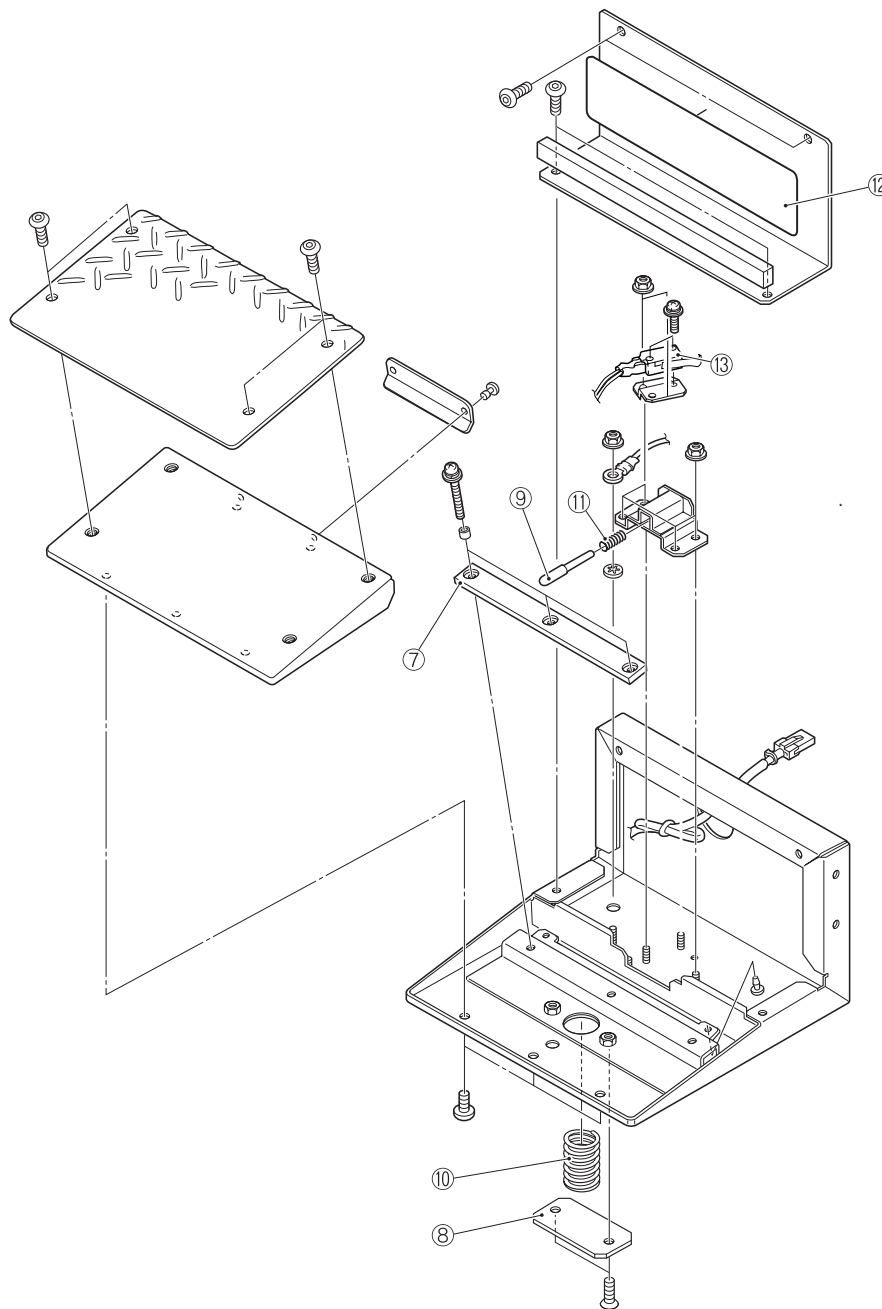

Item	Description	Part No
	Pedal Assy	XTC4-PEDALASSY
7	Stopper Rubber	XTC4-631-217
8	Spring Cover	XTC4-717-324
9	Plunger	XTC4-631-219
10	Spring (A)	XTC4-717-325
11	Spring (B)	XTC4-717-326
12	Pedal Decal	40000762
13	Micro Switch - KSL 13	XTC-000-027

9-9 Gun Tower Assy (L)

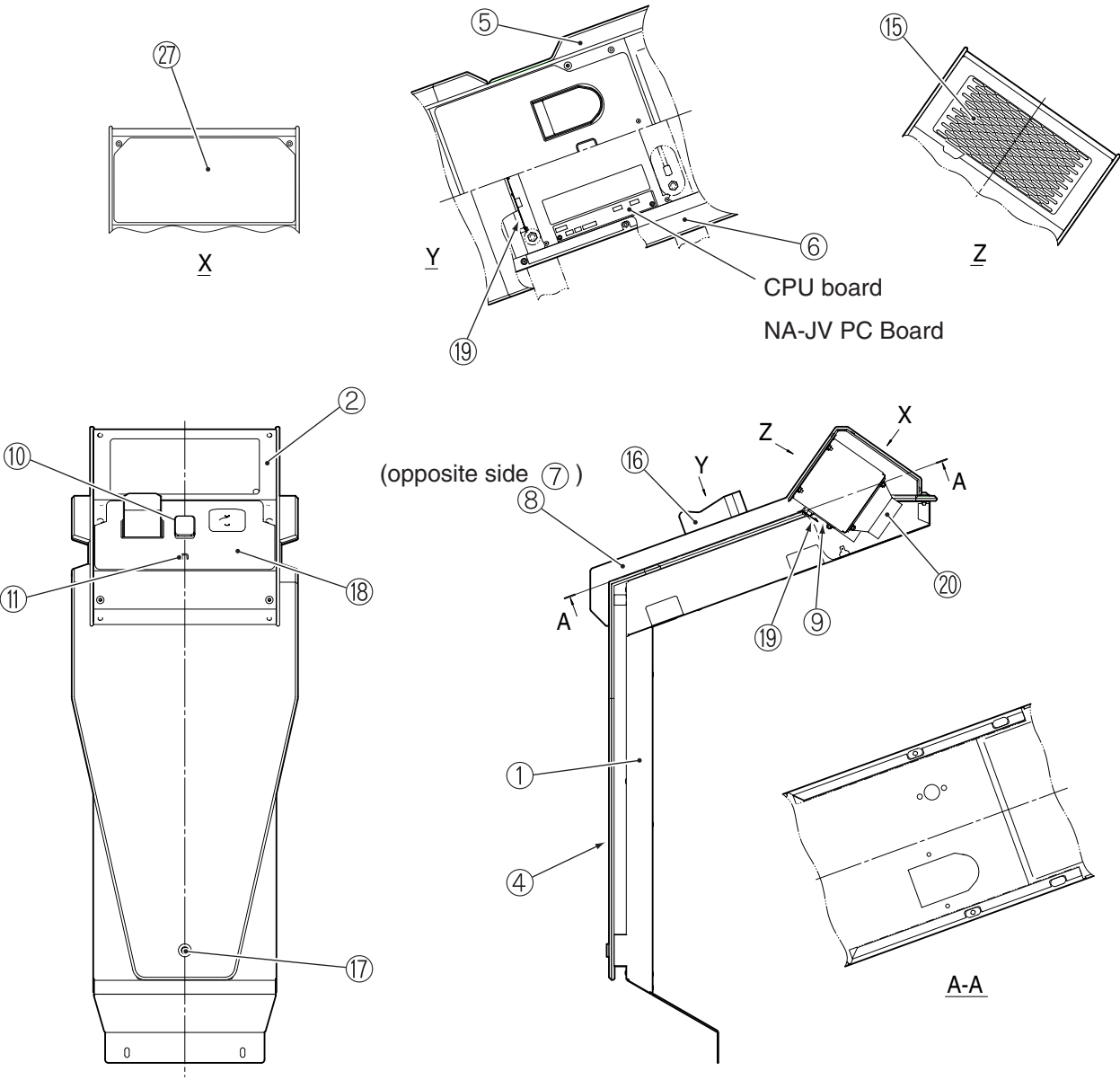

Item	Description	Part No
2	Holster Panel	XTC4-NTC1116-1
4	Acrylic Panel A	30000104
5	Rear Acrylic L	30000105
6	Rear Acrylic R	30000106
7	Gun Tower Side Panel L	30000107
8	Gun Tower Side Panel R	30000108
9	LED Cover	XTC4-NTC3116-1
10	'Credit Available When Lit' Button	60200215
11	Panel Gun Hoop	45000210
15	Speaker Grille	XTC4-NTC1119-1
16	Gun Holder	XTC4-NTC1121-1
17	Countersunk Washer	XTC4-NTC
18	Holster Decal L	40000854
19	SIDELED PC Board (Red)	XTC4-SIDELEDR
20	Speaker	62000162
27	Reflection Preventing Decal	40000860

9-10 Gun Tower Assy (R)

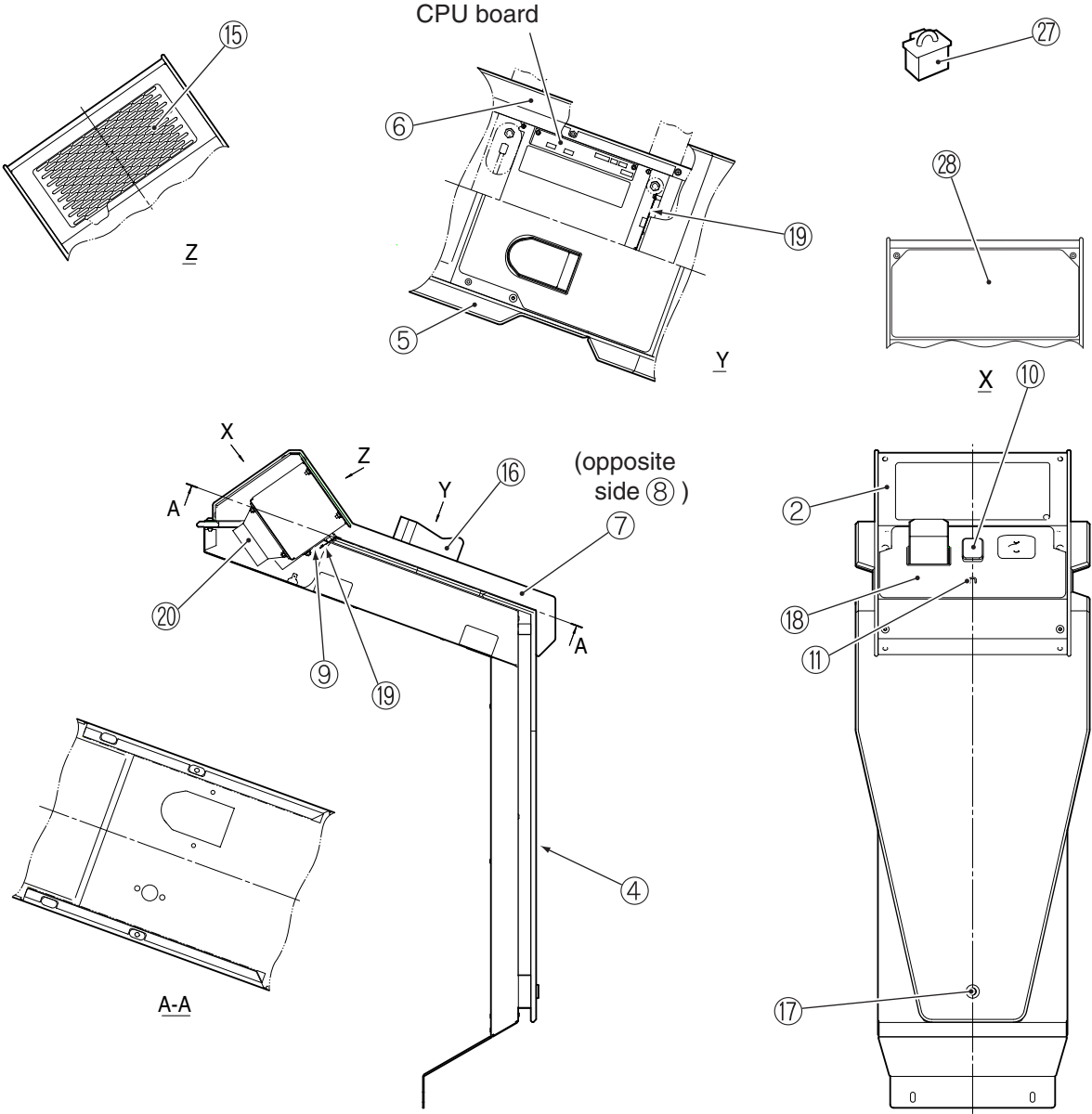

Item	Description	Part No
2	Holster Panel	XTC4-NTC1116-1
4	Acrylic Panel A	30000104
5	Acrylic Panel B	30000105
6	Gun Tower Panel R	30000106
7	Gun Tower Side Panel L	30000107
8	Gun Tower Side Panel R	30000108
9	LED Cover	XTC4-NTC3116-1
10	'Credit Available When Lit' Button	60200215
11	Panel Gun Hoop	45000210
15	Speaker Grille	XTC4-NTC1119-3
16	Gun Holder	XTC4-NTC1121-1
17	Countersunk Washer	XTC4-NTC
18	Holster Decal R	40000855
19	SIDELED PC Board (Blue)	XTC4-SIDELEDB
20	Speaker	62000162
27	Frequency Changeover Connector	XTC4-NTC
28	Reflection Preventing Decal	40000860

9-11 Gun Assy

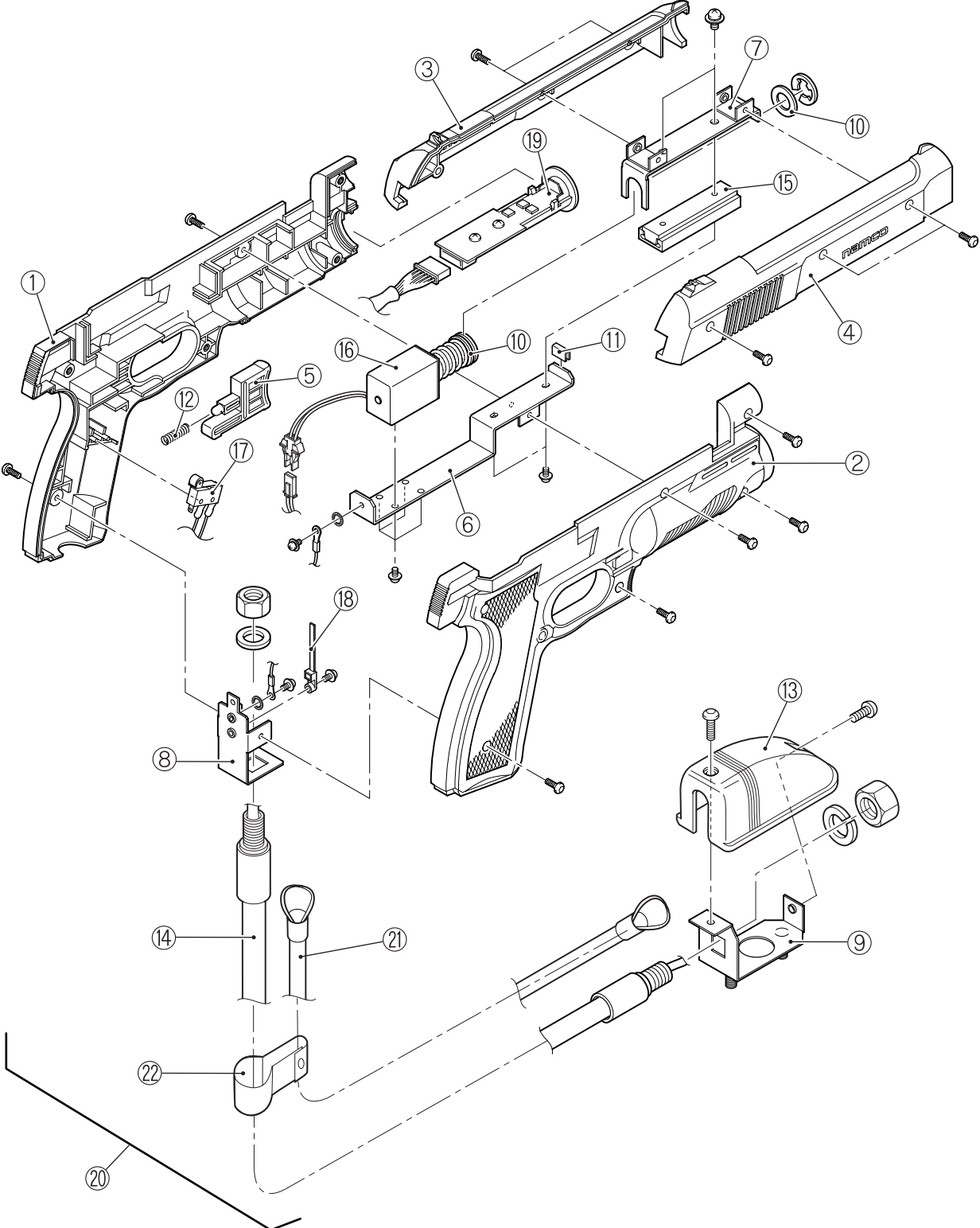

Gun Assy (R) (Red Gun)

Item	Description	Part No
1	Gun Body (LR)	XTC4-717-330
2	Gun Body (RR)	
3	Slide (LR)	XTC4-717-331
4	Slide (RR)	
5	Finger Lever (LR)	XTC4-717-332
6	Solenoid Bracket	XTC4-717-303
7	Slide Bracket	XTC4-717-304
8	Tube Bracket (A)	XTC4-717-305
9	Tube Bracket (B)	XTC4-717-306
10	Rubber Spacer	XTC4-717-307
11	Rubber Stopper	XTC4-717-308
12	Trigger Spring	XTC4-717-309
13	Connector Cover (B)	XTC4-701-906
14	Gun Harness Assy	XTC4-717-340
15	Slide Rail	XTC4-107-150
16	Solenoid Unit	XTC4-717-316
17	Microswitch	XTC4-000-666
18	Pantai (Convex)	XTC4-007-143
19	Light Receiving Unit	XTC4-306-754
20	Gun Assy (Red)	XTC4-717-333
21	Strain Relief Rope	45000708
22	Gun Chain Clamp	45000211

Gun Assy (B) (Blue Gun)

Item	Description	Part No
1	Gun Body (LB)	XTC4-717-350
2	Gun Body (RB)	
3	Slide (LB)	XTC4-717-351
4	Slide (RB)	
5	Finger Lever (LB)	XTC4-717-352
20	Gun Assy (Blue)	XTC4-717-355

9-12 Joint Box Assy

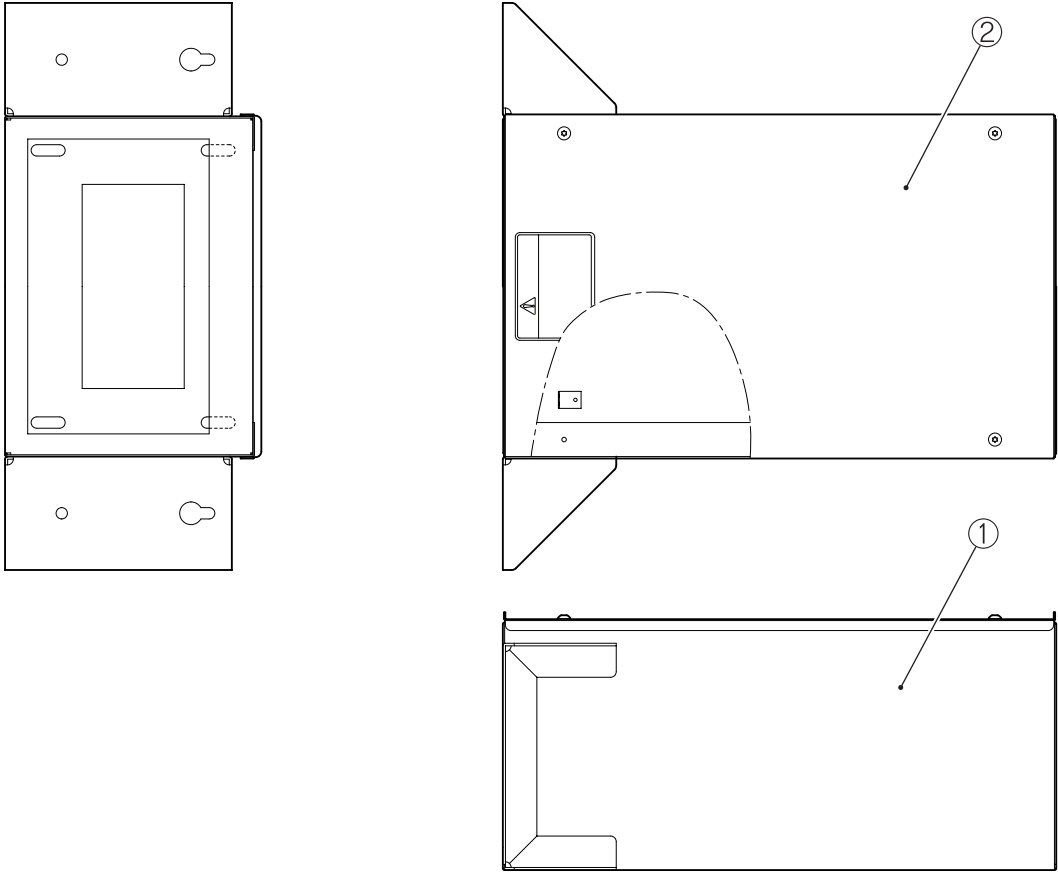

Item	Description	Part No
1	Joint Box	XTC4-NTC1108-2
2	Joint Cover	XTC4-NTC1109-2

10. DISPOSAL

NOTICE

**Directive 2002/96/EC
(Waste Electrical and Electronic Equipment - WEEE)
Information for users**

**This product complies with the EU Directive 2002/96/EC.
The crossed out wheelie bin symbol on the product means that at
the end of its useful lifespan, the product must be disposed of
seperately from ordinary household wastes.**



**Appropriate separate collection to permit recycling, treatment and
environmentally compatible disposal helps prevent negative
impact on the environment and human health.**

**For areas not in the EEC please ensure that disposal of this
product complies with all local legislation or requirements in
force.**

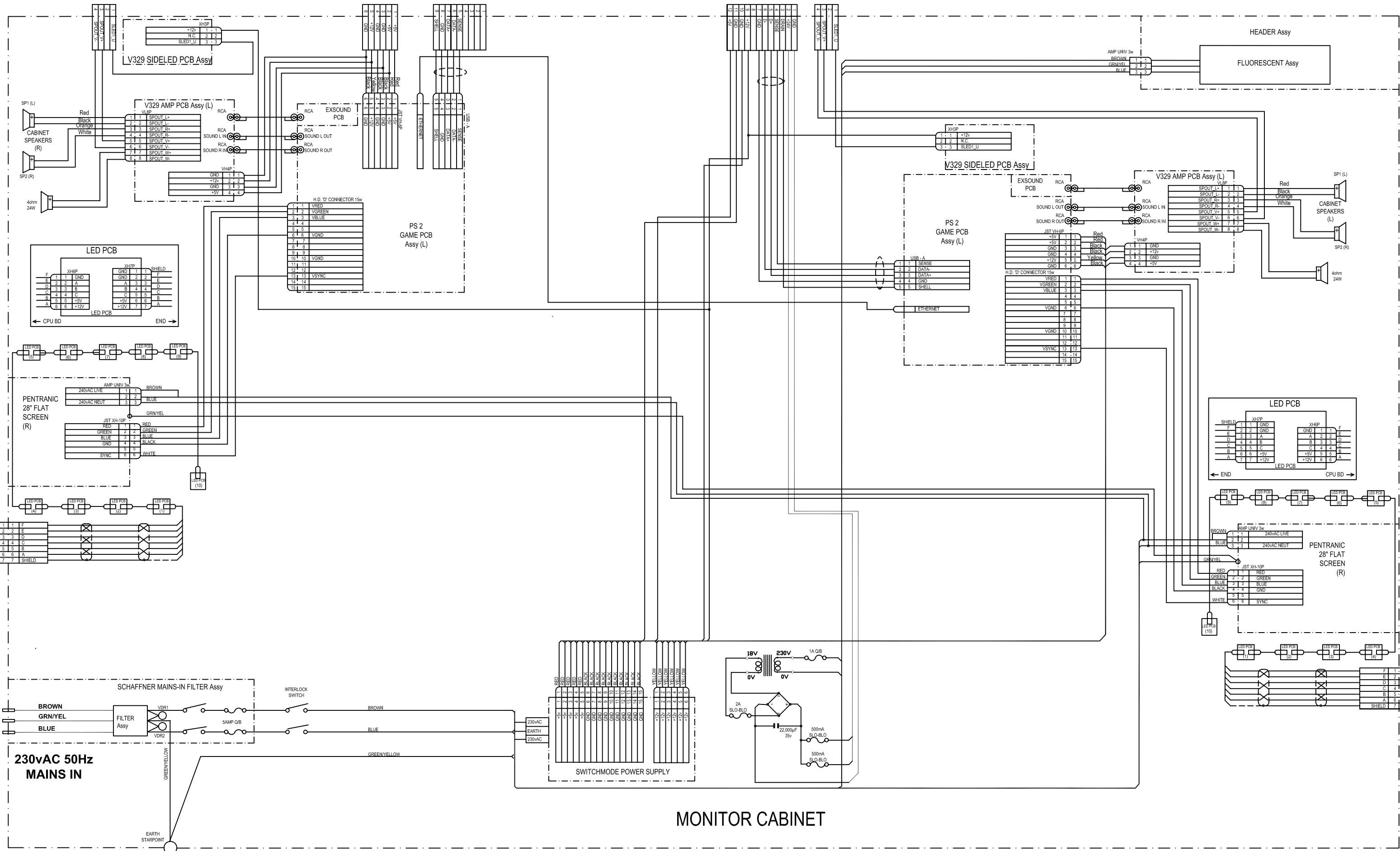

MONITOR CABINET

TIME CRISIS 4 STD SCHEMATIC MONITOR CABINET

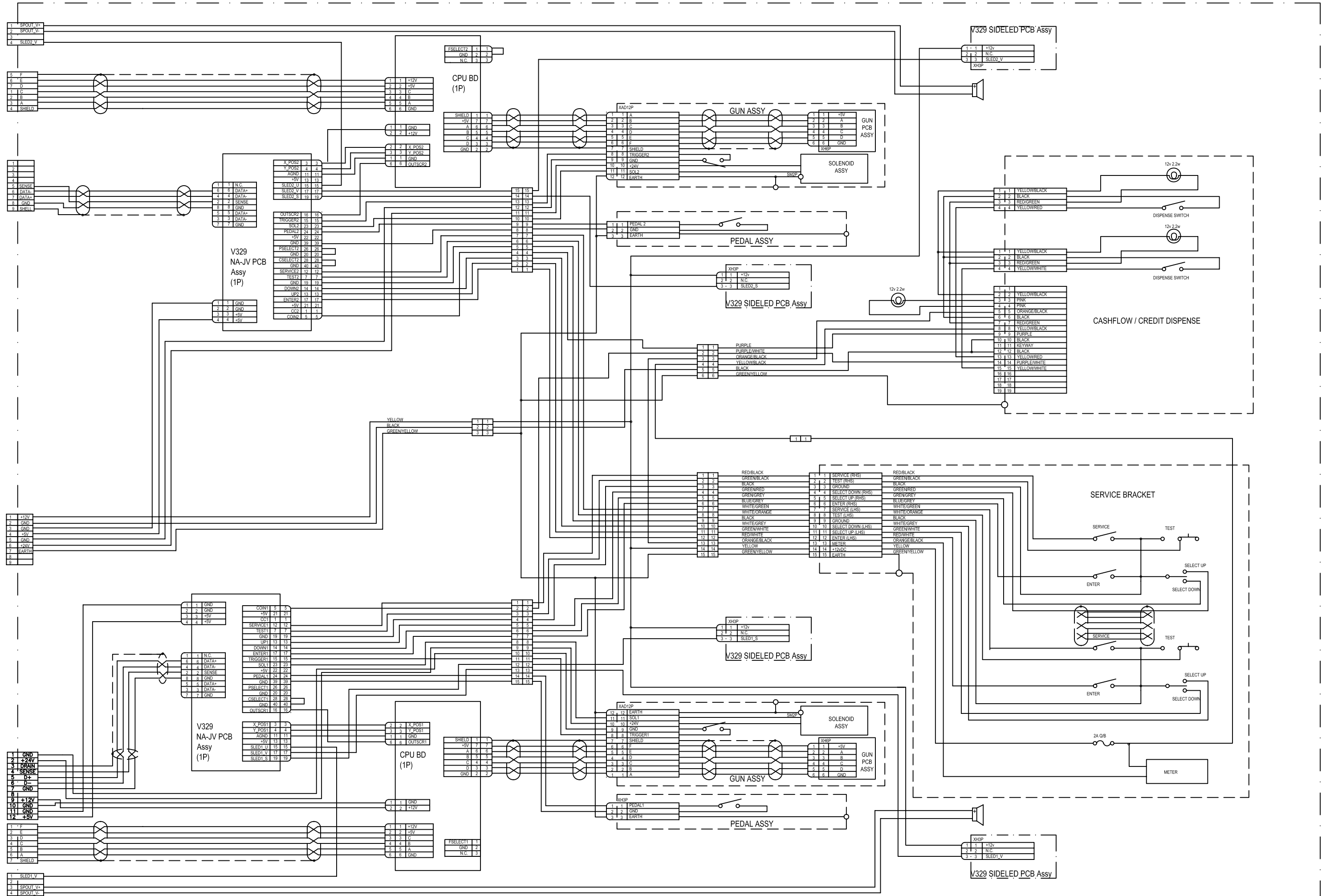

TIME CRISIS 4 STD SCHEMATIC GUN CABINET

Copies of Namco Game Manuals can be downloaded from our website:
www.namco.co.uk
listed under Components Distribution

For all Parts or Technical Support contact:

Brent Electronic,
Namco House,
Units 7-8, Acton Park Estate,
The Vale,
London. W3 7QE

www.brentelectronic.co.uk

For Technical Support, Warranty and
Advance Replacement Parts:-  +44 (0) 20 8324 6120

For Consumable Parts:-  +44 (0) 20 8324 6102

Fax for both:-  +44 (0) 20 8324 6126