

PAC-MAN™ BASKET

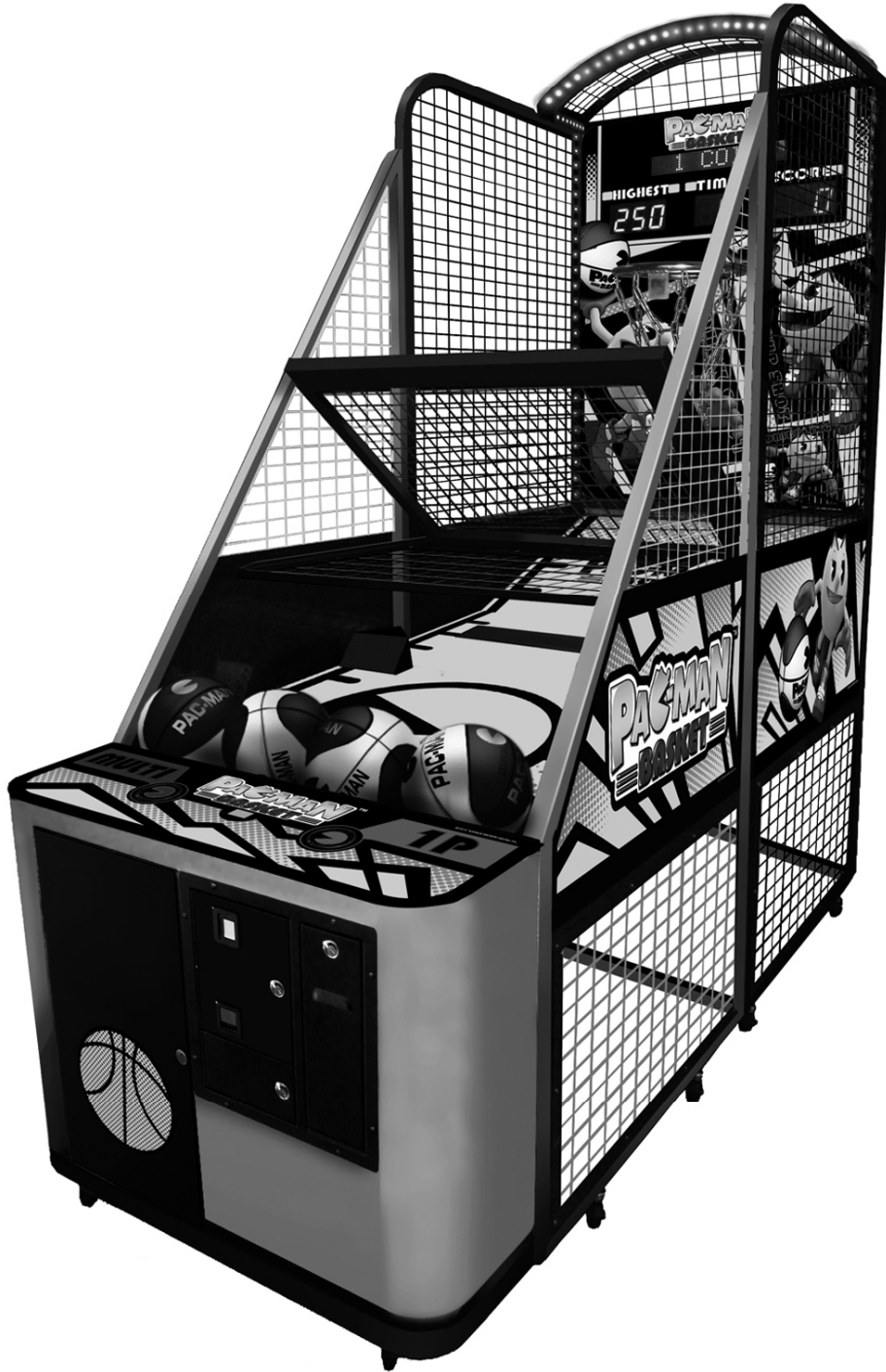

MANUAL

Table of Contents

Special note	3
Maintenance and Inspection	3
I. Inspection	3
1. Parts list.....	4
2. Half-Assembly type parts list	5
II. Machine view/size and power rating	6
III. Component description.....	6
IV. Assembly and disassembly.....	7
1. Assembly and disassembly for Disassembly type	7
2. Assembly and disassembly for Half-Assembly type.....	17
3. 【SET-UP Position & maintenance】	24
V. Adjustment and Inspection	24
1. Link adjustment	25
【Cable link SET-UP】	25
【Link main board adjustment】	26
2. Adjustment	27
【SET-UP 1】 SET-UP the coin entry price for each game	27
【SET-UP 2】 Additional tickets	28
【SET-UP 3】 Multiple of tickets	28
【SET-UP 4】 Game Time SET-UP	29
【SET-UP 5】 Basket motor AUTO test	30
【SET-UP 6】 Ball holder motor AUTO test	30
【SET-UP 7】 Reset the top score 250 or keep the record	30
【SET-UP 8】 SET-UP DEMO music (ON or OFF)	30
3. LED Monitor inspection	31
4. AUDIT.....	31
5. Error code.....	32
VI. How to play.....	33
1. There are total 4 Stages	33
2. 2 play types available	33
VII. Screw and Nut list	34
VIII. Wires Layout	36
IX. Expanded view	38

Special note

We would like to thank you for choosing our Street basketball machine,
Please read this manual before using this product to insure the
security of the user.

This Manual contains the characteristics, special notes, and a
simple breakdown of the product.

Maintenance and Inspection

- Keep the machine clean by using mild types of cleaners.
- Clean the machine regularly to maintain its appearance.
- The appliance must not be cleaned by a water jet.
- Treat acrylic with care by using Windex



※Machine position regulation

The power must be turned off before any movement.

The brake must be released, before moving the machine.











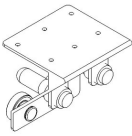
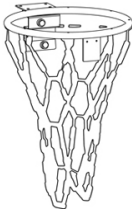
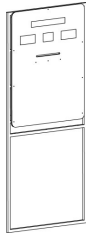
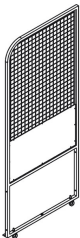
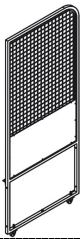

Do not put the machine under direct sunlight, it will damage the inside parts.

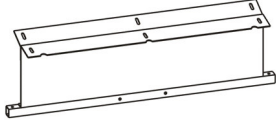
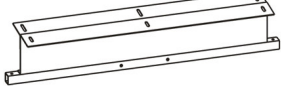
I. Inspection



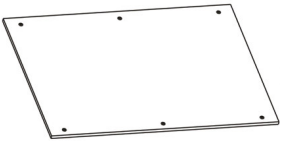
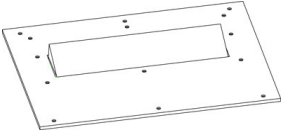
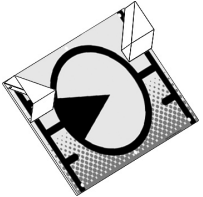

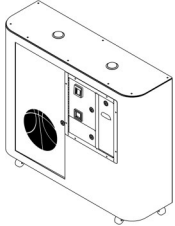
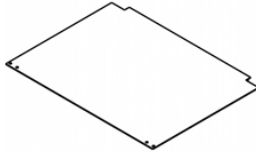
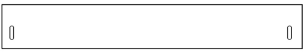
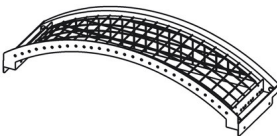
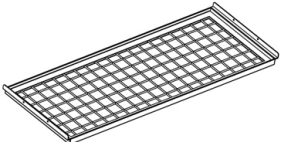
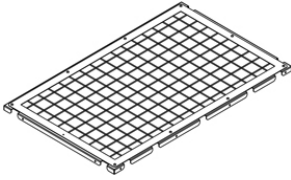
Before product use, please confirm the product content first, if anything is missing, please contact us right away.

NO	Items	Specification	Total quantity
1	Chassis items	Packing	1 unit
2	Basketball	No.5 Basketball	10 unit
3	Key	Maintenance door	1 pc
4	Key	Cash box	1 pc
5	AC cable line		1 unit
6	Operation manual	A4	1 set

1.Parts list

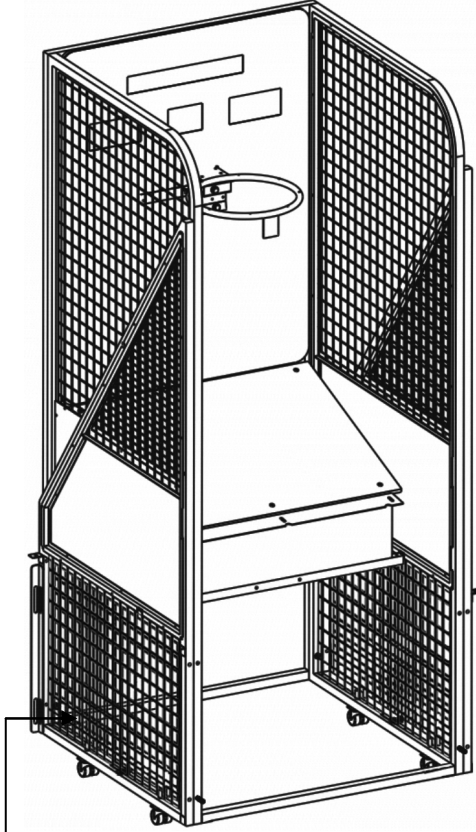
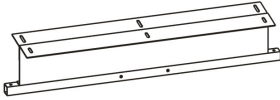
<p>1A Sensor for basket (WO-RNPW2)</p> 	<p>1B Basket kits</p> 	<p>2A Basket board</p> 	<p>2BR Back right net stander kit</p> 
<p>2BL Back left net stander kit</p> 	<p>2C 2 Front net stander bridge(short)</p> 	<p>3A Front right net stander kit</p> 	<p>3B Front left net stander kit</p> 
<p>4A Base holder BF</p> 	<p>4B Base holder FB</p> 	<p>4C Base holder FF</p> 	<p>4D Base holder BB</p> 
<p>4E Base holder FF (Bottom)</p> 	<p>5A Wooden board A type</p> 	<p>5B Ball holder kit</p> 	<p>5C Ball guide kits</p> 
<p>6A Ball net holder kit</p> 	<p>6B Main part</p> 	<p>6C Block wooden board for motor</p> 	<p>6E Rubber pad</p> 
<p>Top cover</p> 	<p>Metal Shelf (optional)</p> 	<p>Lower Side Net (Frame Included)×4</p> 	<p>Basketball</p> 

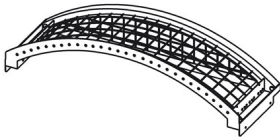
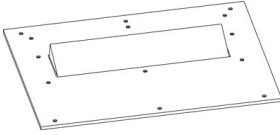
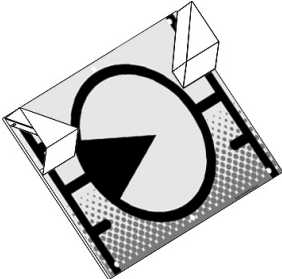
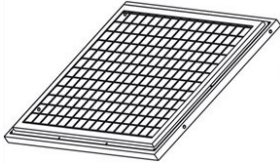
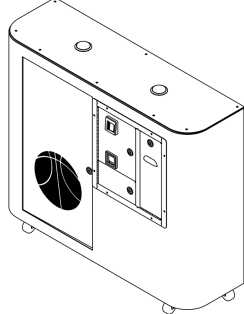
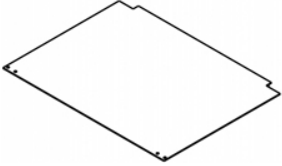
2.Half-Assembly type parts list

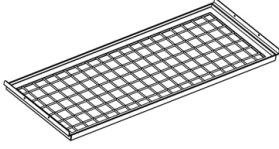
<p>Main frame</p>  <p>Lower Side Net(Frame Included)×4</p>	<p>4B Base holder FB</p> 
<p>4C Base holder FF</p> 	<p>Top cover</p> 
<p>5B Ball holder kit</p> 	<p>5C Ball guide kits</p> 
<p>6A Ball net holder kit</p> 	<p>6B Main part</p> 
<p>6C Block wooden board for motor</p> 	<p>Basketball</p> 
<p>Metal Shelf (optional)</p> 	

II. Machine view/size and power rating

Machine Dimensions : W1030×D2500×Top cover H2643mm
 Weight : 260 kg / 558.4 lbs (Accessories not Included)
 (Top cover 6.6kg 、 Metal Shelf 3.4kg 、 Lower Side Net 4.2kg×4)
 Voltage : AC110V~120V/AC220V~240V(50/60Hz) Use Electrical
 plug display as a guide Located behind the machine.
 Power Consumption : 200W
 Fuse : 3A
 Token size : Ø22mm~27mm

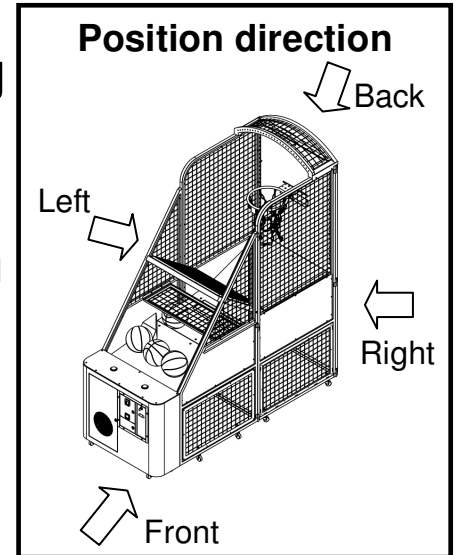

III. Component description

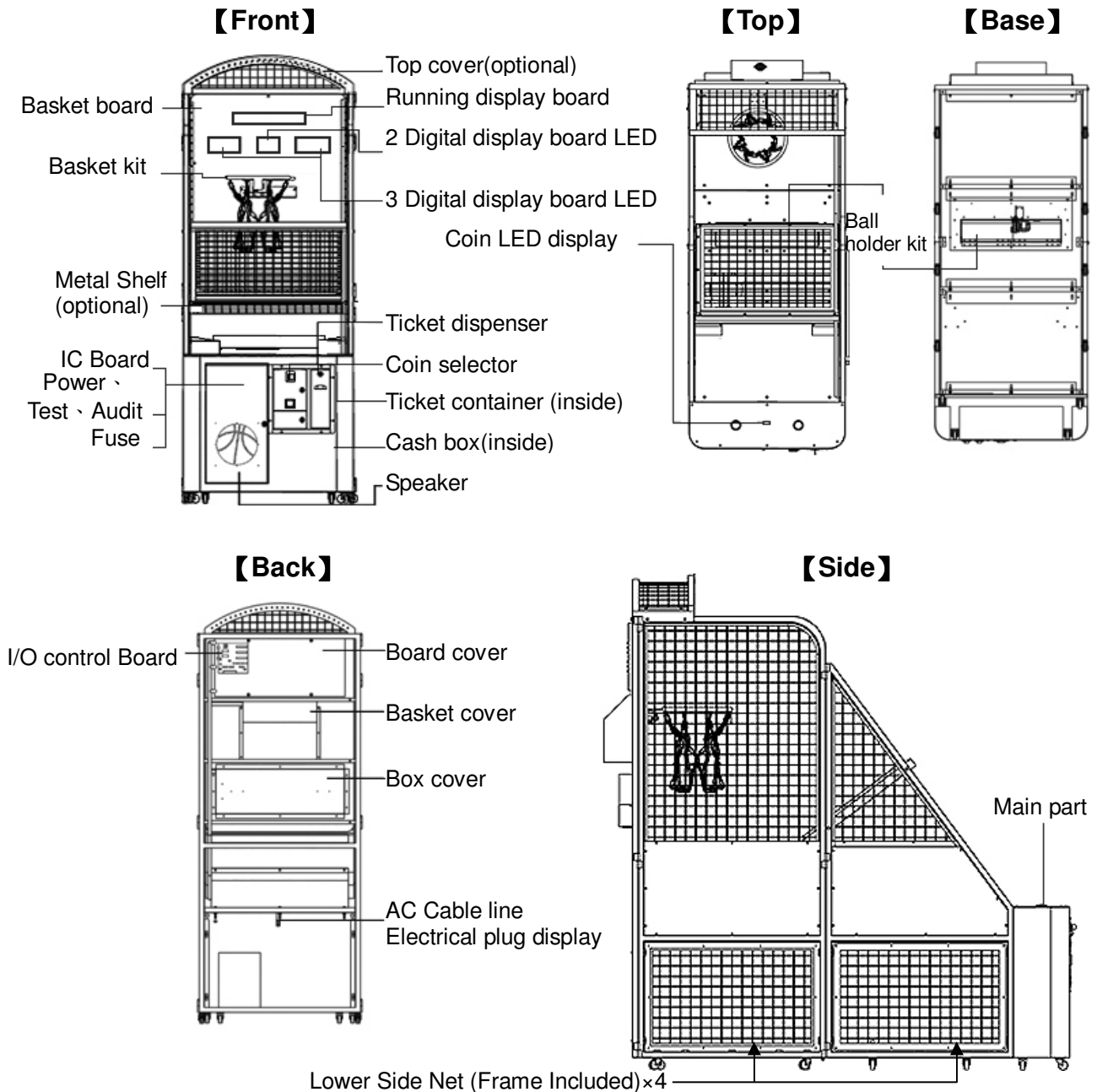

IV. Assembly and disassembly

1. Assembly and disassembly for Disassembly type

Step 1 :

1.Screw 【Lower Side Net (optional)】 on the basket board front.

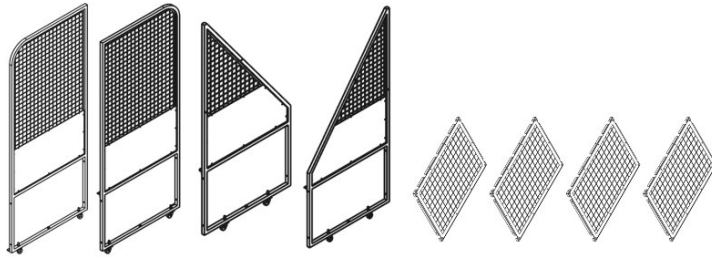

Assembly parts

- 2BR Back right net stander kit
- 2BL Back left net stander kit
- 3A Front right net stander kit
- 3B Front left net stander kit
- Lower Side Net(Frame Included)

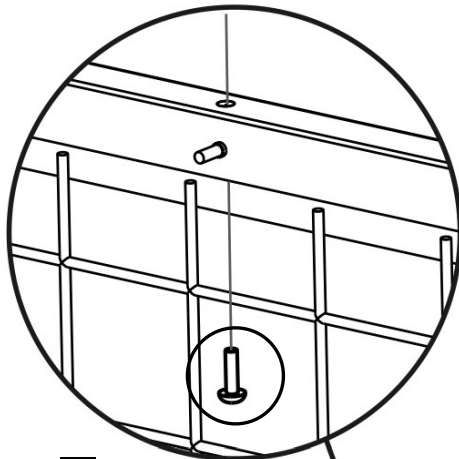

P.35 NO.32
screw(M4×10)×10

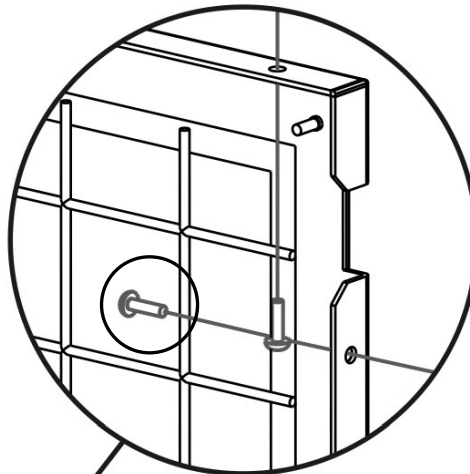

P.35 NO.32
screw(M4×10)×10

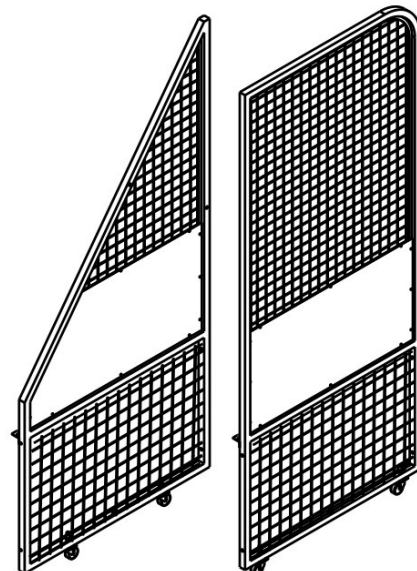
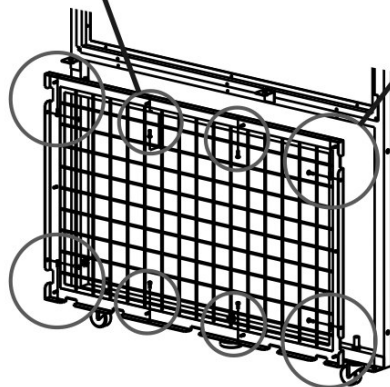



Step 2 :

1.Screw 【1B Basket kits】 on the basket board front.

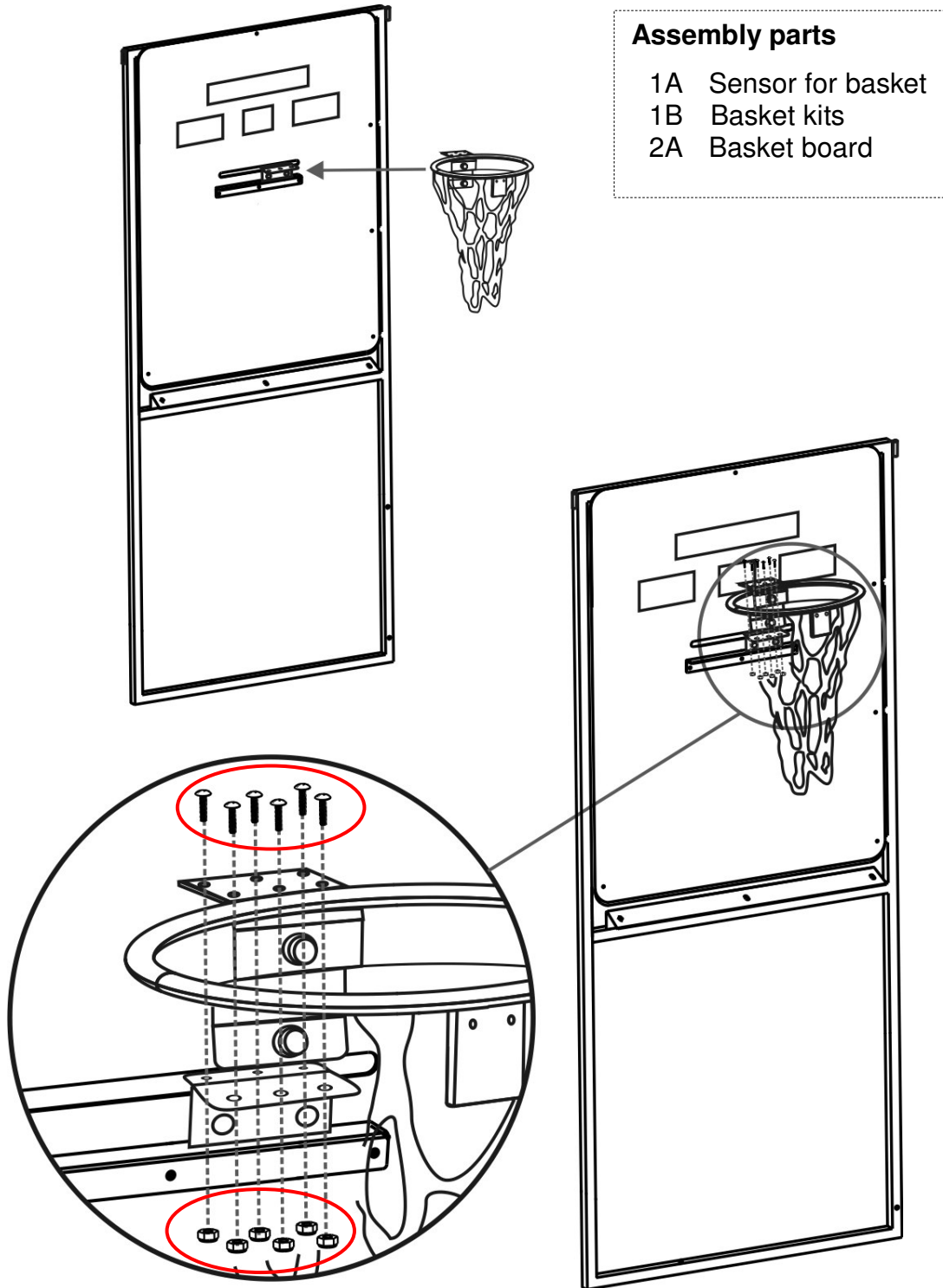

- Assembly parts**
- 1A Sensor for basket
 - 1B Basket kits
 - 2A Basket board

P.34 NO. 13 screw(M5×15)×6

P.35 NO. 21 nut(M5)×4



Step 3 :

1. Screw 【2BR · 2BL Back left & right net stander kits】 on basket board left and right.
2. Screw 【2C Front net stander bridge(short)】 on Back left & Right net stander kits.

Assembly parts

- 2A Basket board
- 2BR Back right net stander kit
- 2BL Back left net stander kit
- 2C Front net stander bridge(short)

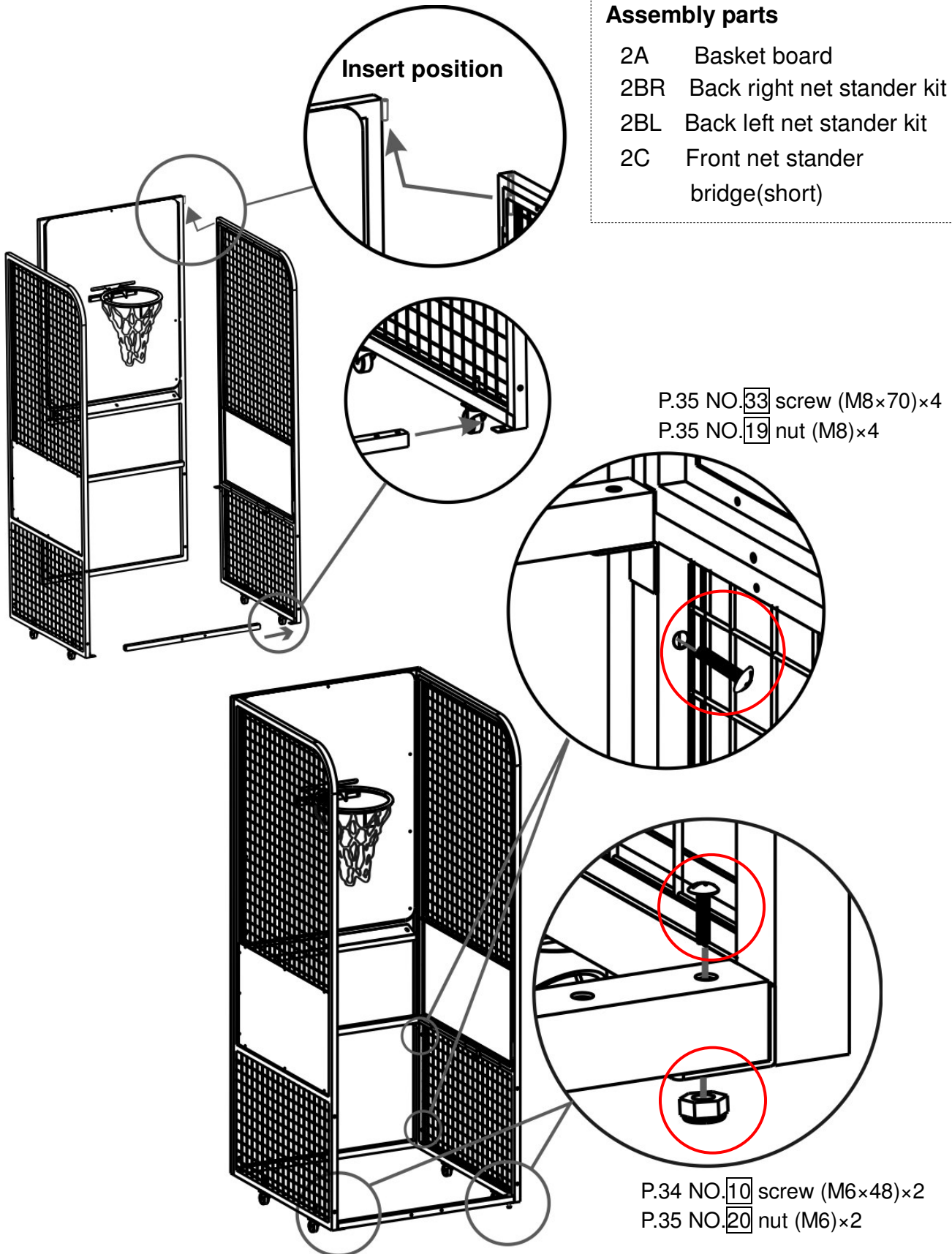



Step 4 :

Assemble【3A·3B Front right & left net stander kit】on basket board left and right, connect with screw & fixed it as drawing.

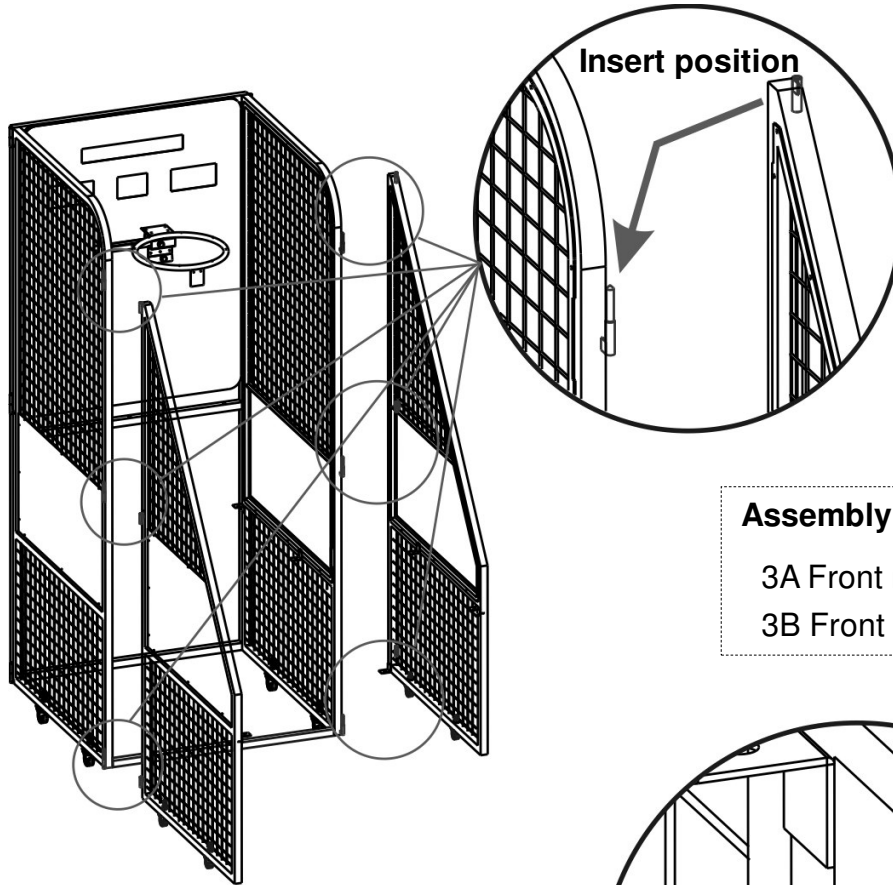

Assembly parts

- 3A Front right net stander kit
- 3B Front left net stander kit

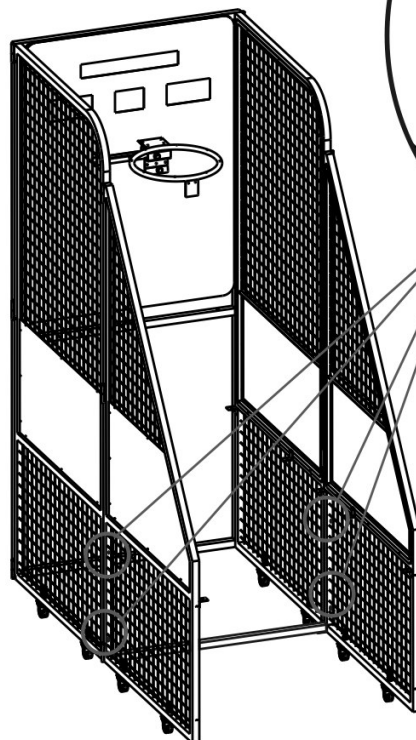

- P.35 NO. 33 screw (M8×70)×4
- P.35 NO. 19 nut (M8)×4



Step 5 :

Screw the [BF · FB · FF Base holders & Front net stander bridge(short)] step by step as drawing.

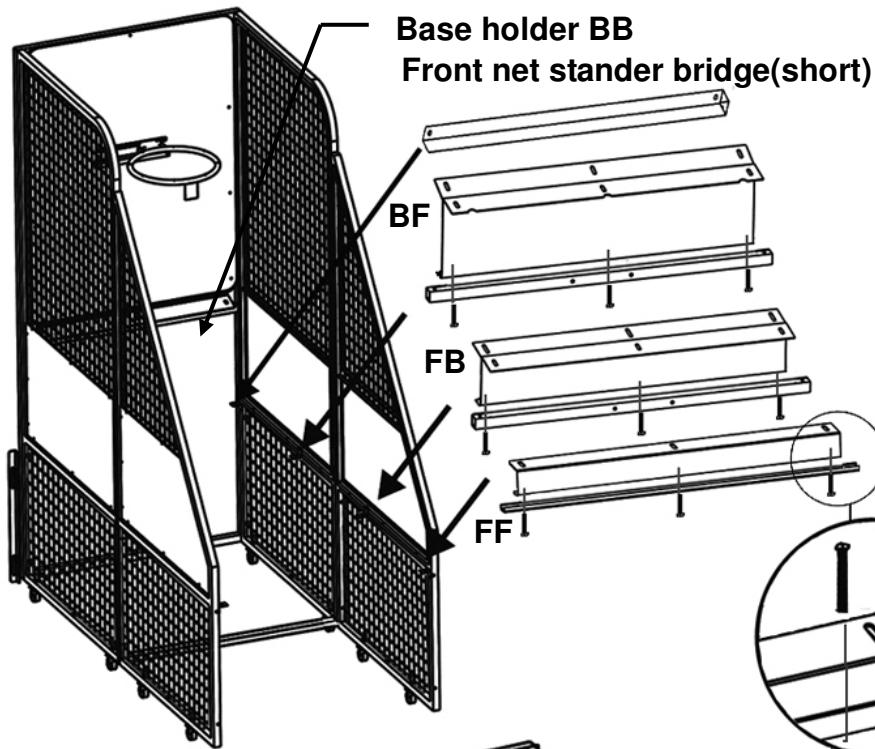

- Assembly parts**
- 2C Front net stander bridge(short)
 - 2E 2 Front net stander bridge(long)
 - 4A Base holder BF
 - 4B Base holder FB
 - 4C Base holder FF
 - 4D Base holder BB
 - 4E Base holder FF (Bottom)

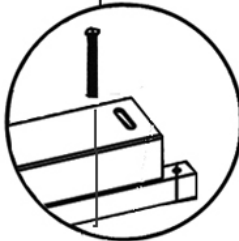

- P.34 NO. 10 screw (M6×48)×9
- P.35 NO. 20 nut (M6)×9
- P.35 NO. 30 washer(M6.5×13.5)×9

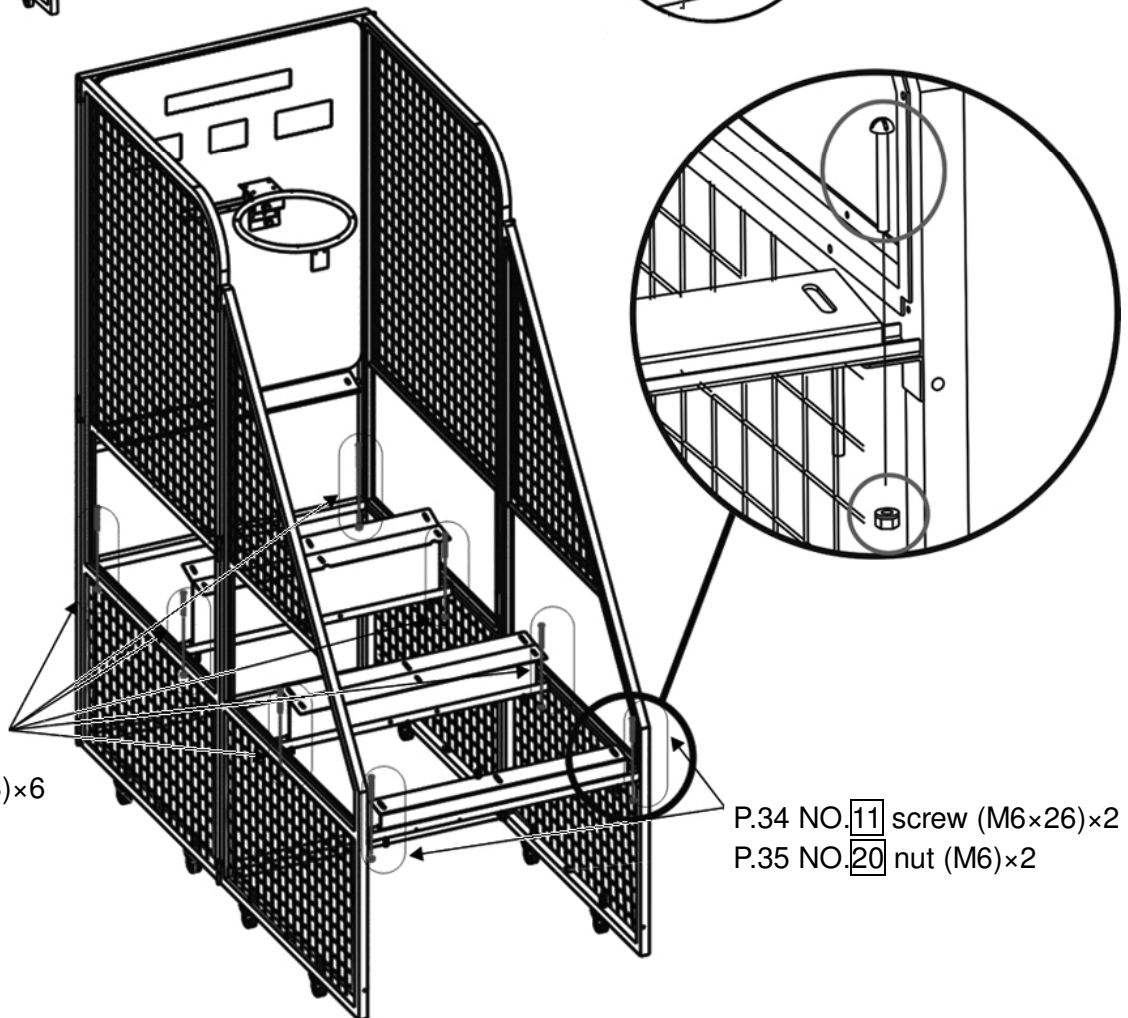

- P.34 NO. 10 screw (M6×48)×6
- P.35 NO. 20 nut (M6)×6

- P.34 NO. 11 screw (M6×26)×2
- P.35 NO. 20 nut (M6)×2



Step 6 :

Screw the 【5A Wooden base A type · 5B Ball holder kit · 5C Ball guide kits】 step by step as drawing.

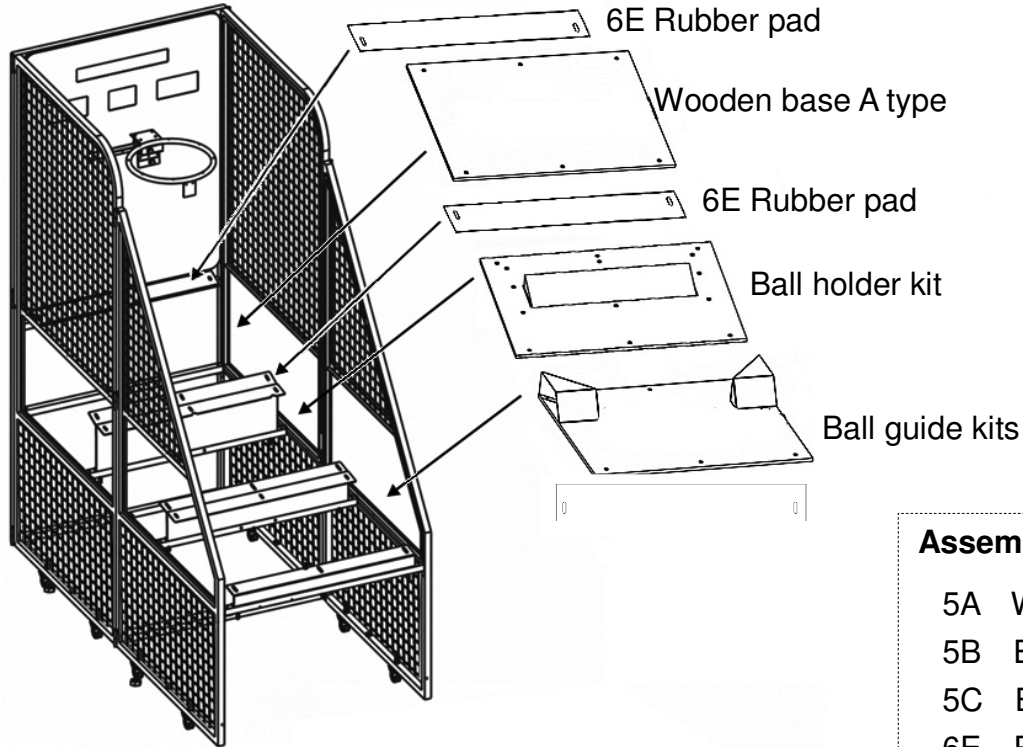

Assembly parts

- 5A Wooden board A type
- 5B Ball holder kit
- 5C Ball guide kits
- 6E Rubber pad

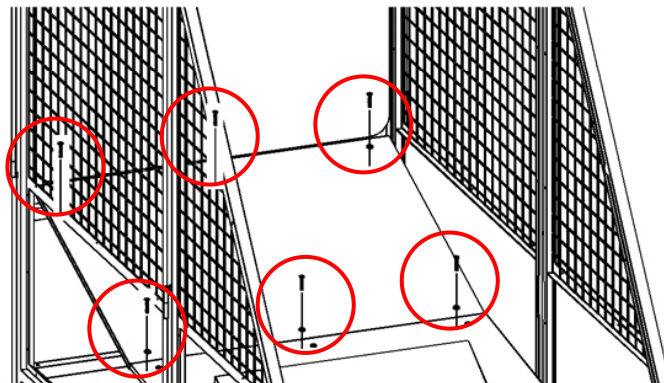

- P.34 NO. 10 screw (M6×26) ×6
- P.35 NO. 20 nut (M6) ×6
- P.35 NO. 30 washer (M6.5×13.5) ×6

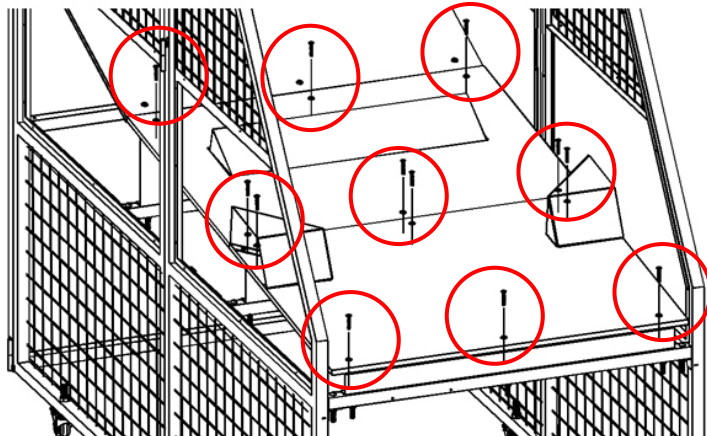

- P.34 NO. 11 screw (M6×26)×12
- P.35 NO. 20 nut (M6)×12
- P.35 NO. 30 washer (M6.5×13.5) ×12



Step 7 :

1. Screw 【6A Ball net holder kit】 .
2. Screw 【6B Main part】 、 【Metal Shelf (optional)】 .

Assembly parts :

- 6A Ball net holder kit
- 6B Main part
- Metal Shelf (optional)

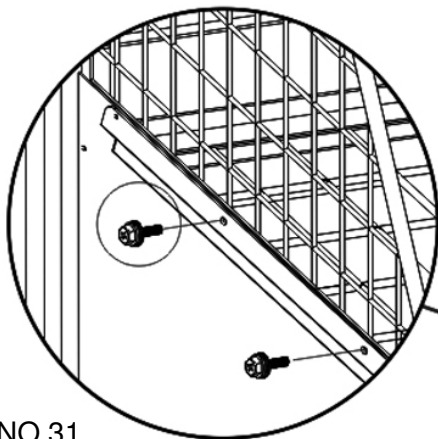
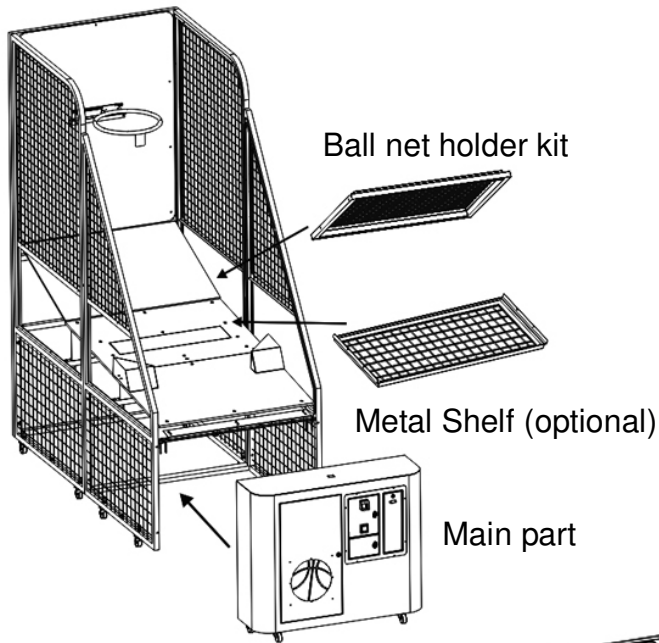

P.35 NO.31
Hexagonal Phillips screw with 2
Washers included 2 on each side

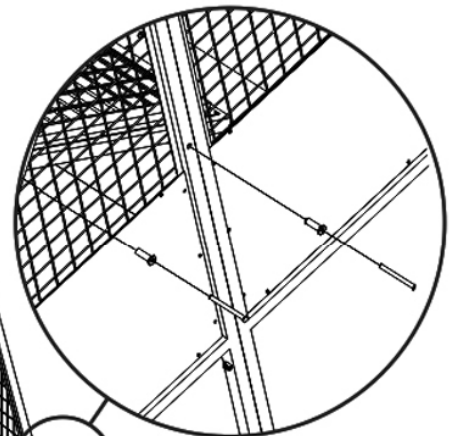

P.34 NO.04
screw (M8×88)×4
P.35 NO.19 nut(M8)×4
P.35 NO.27
sleeve(φ 15×43)×4

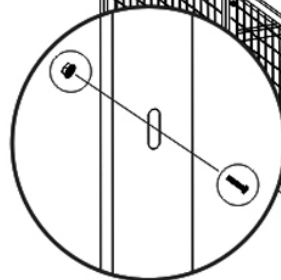

P.34 NO.08 screw (M8×16)×4
P.35 NO.19 nut (M8)×4
P.35 NO.30 washer(M10×20)×4



Step 8 :

1. Fix the 3 main cords as the following drawing.
2. Run the IC board plug and the ball holder kit plug located underneath the front of the ball net holder, through the hole in back of the main part.
3. Now connect plugs as shown in drawing.

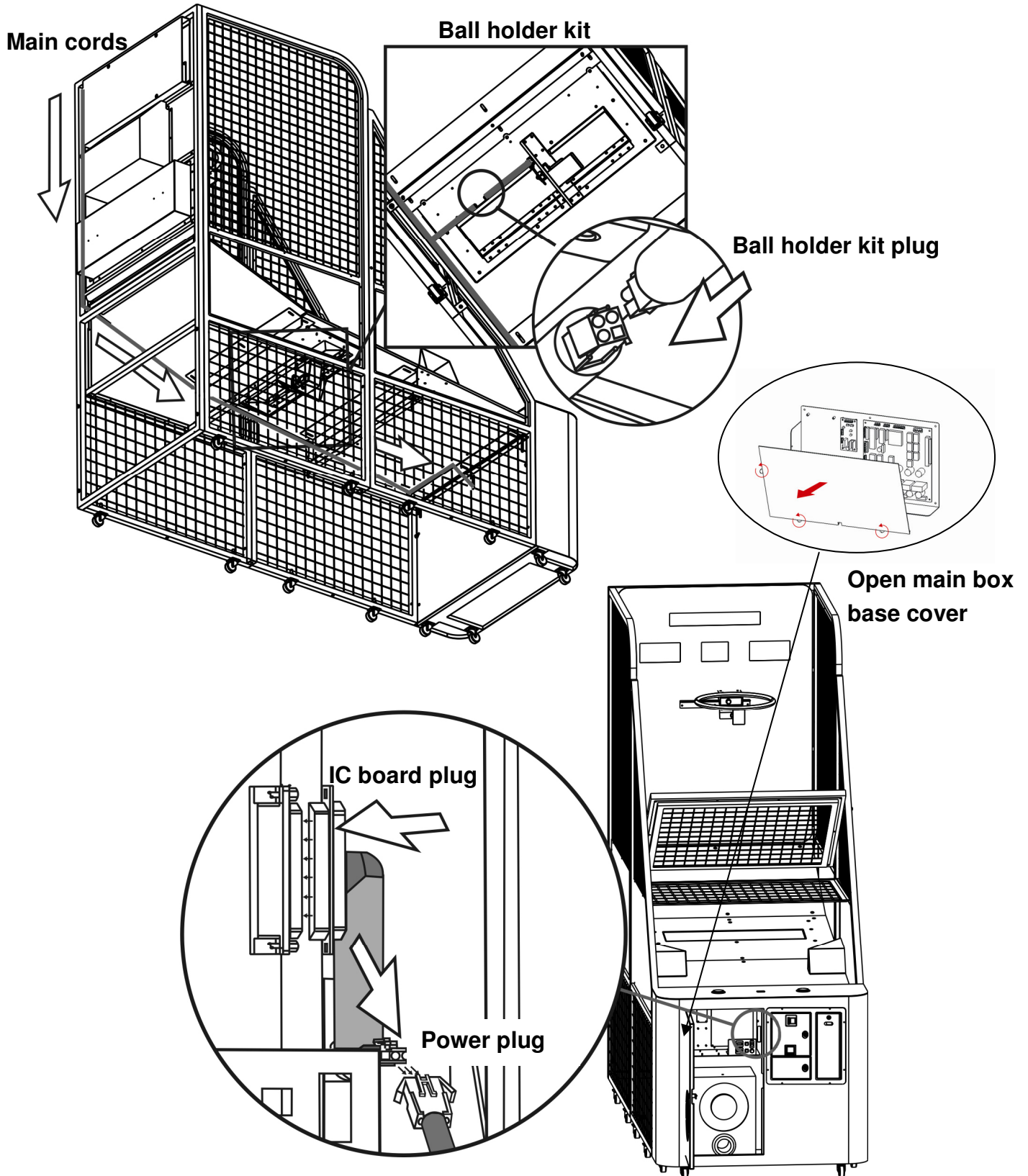



Step 9 :

Screw 【Top cover(optional)】 step by step as drawing.

Assembly parts

Top cover(optional)

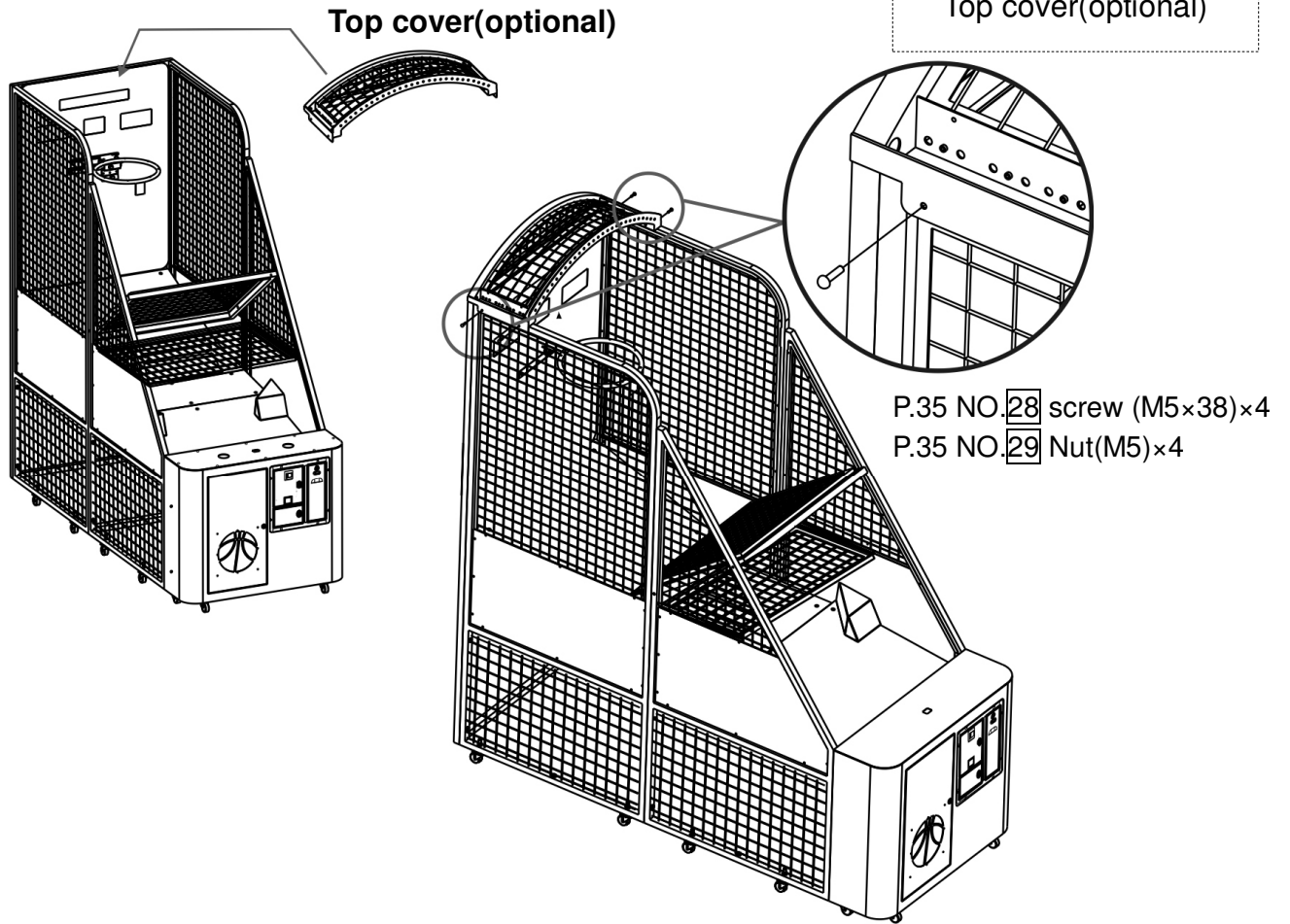

Step 10 :

1. connect the I/O control board with Top cover.
2. Now connect plugs as shown in drawing.

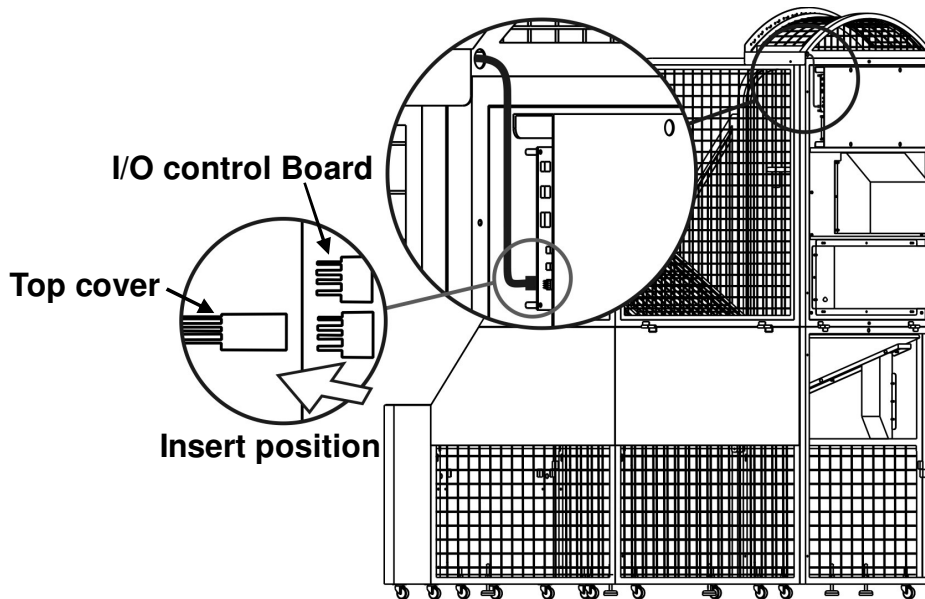



Step 11 :

Use screws to fix it then complete the assembly street basketball.

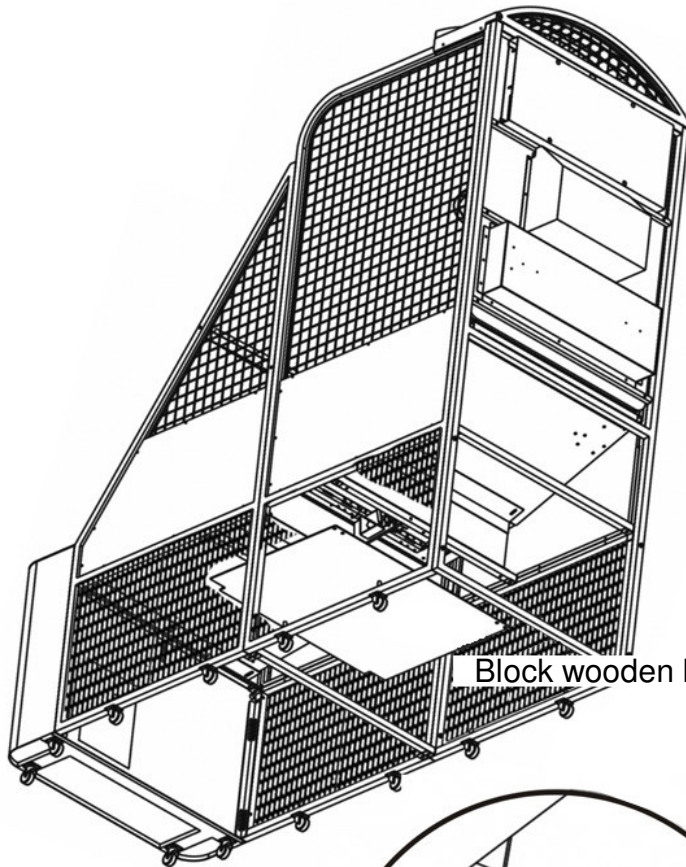

Assembly parts

6C Block wooden board
for motor

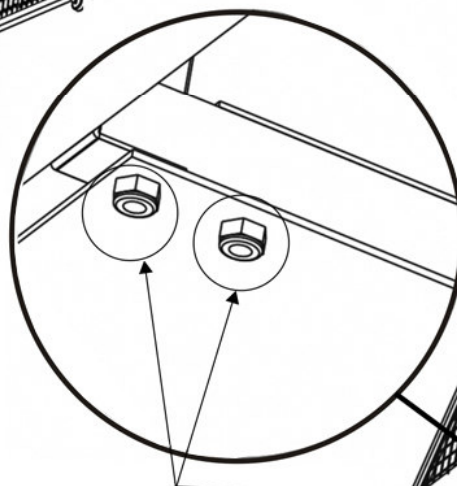

P.35 NO. 20 nut(M6)×4

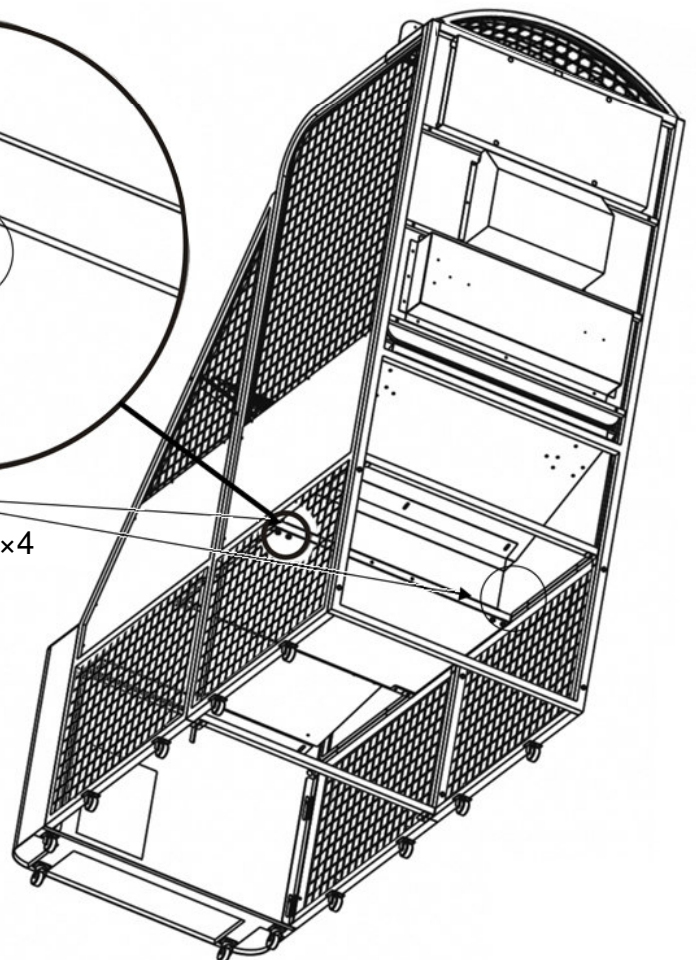

2. Assembly and disassembly for Half-Assembly type

Step 1 :

Turn the left and right frame 180° to the position as drawing picture . connect with screw & fixed it as drawing.

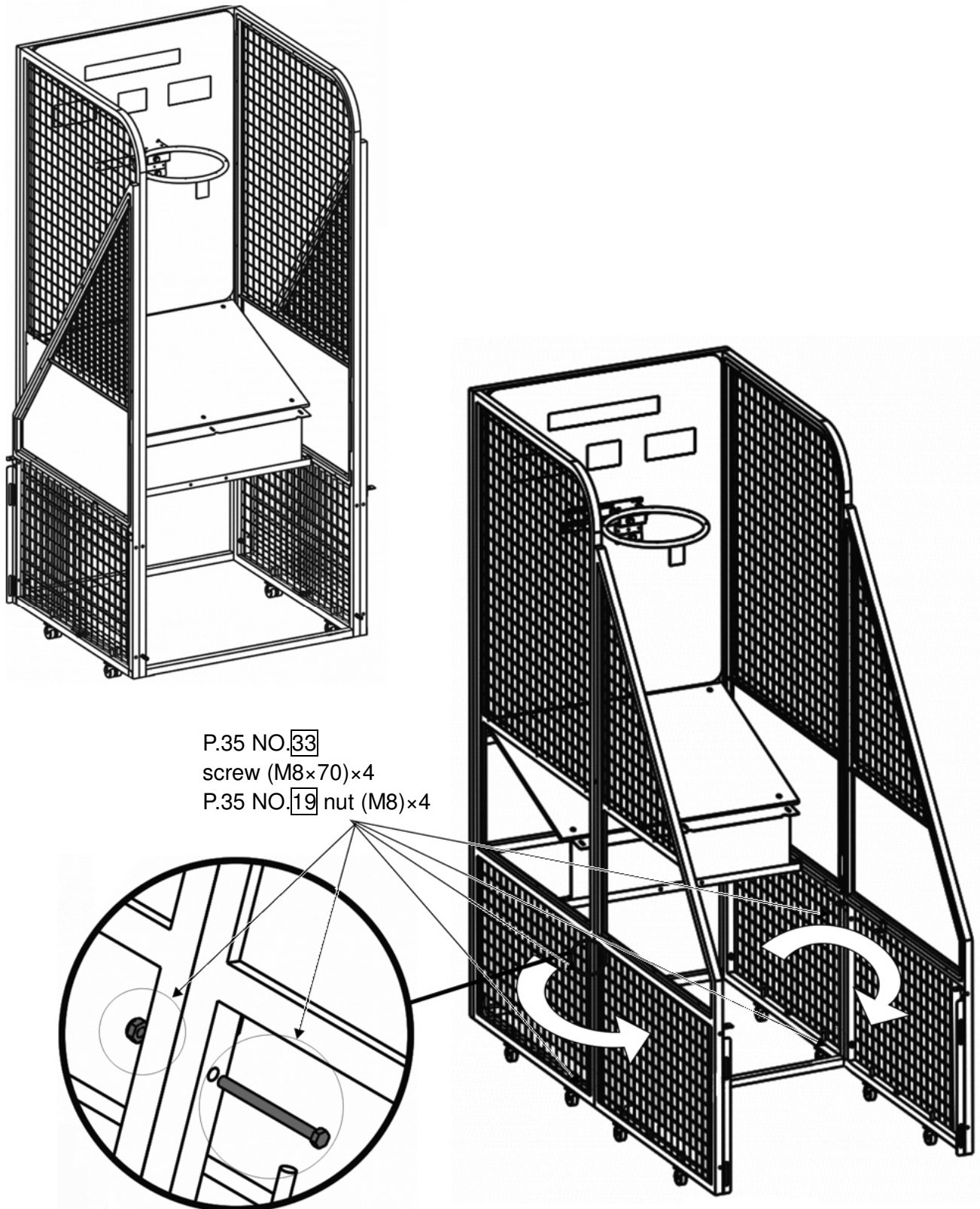



Step 2 :

Screw the base frame FB and base frame FF as drawing picture.

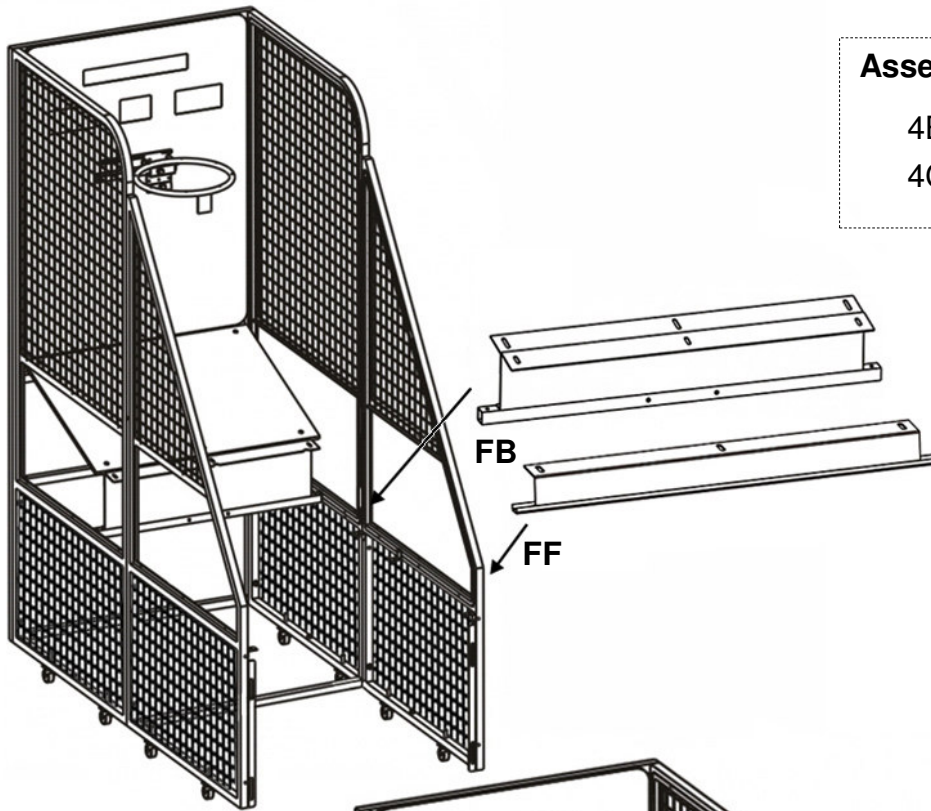

Assembly parts

- 4B Base holder FB
- 4C Base holder FF

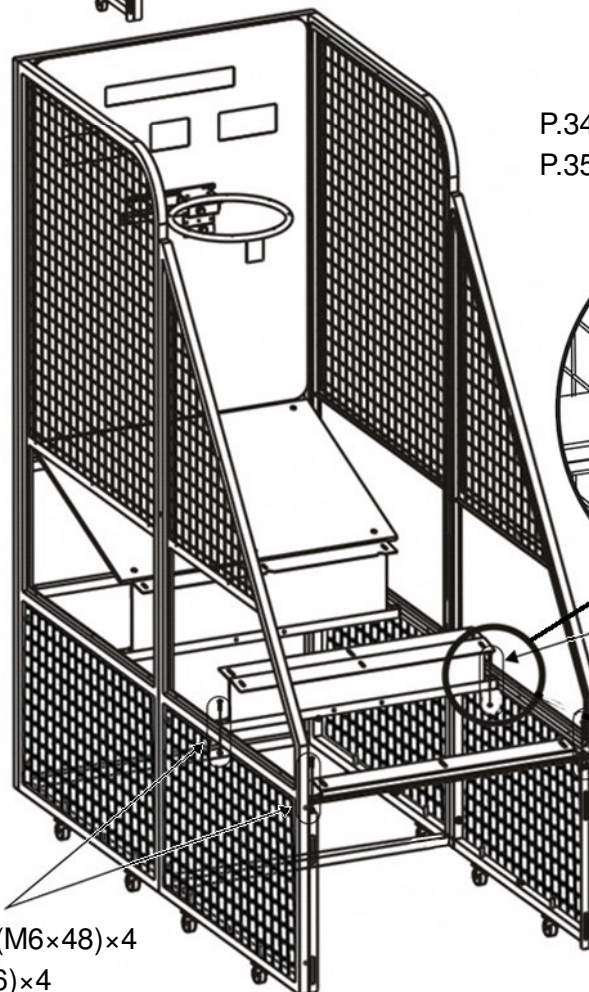

- P.34 NO. 11 screw (M6×26)×2
- P.35 NO. 20 nut (M6)×2

- P.34 NO. 10 screw (M6×48)×4
- P.35 NO. 20 nut (M6)×4



Step 3 :

Screw the 5B Ball holder kit and 5C Ball guide kits as drawing picture.

Assembly parts

- 5B Ball holder kit
- 5C Ball guide kits

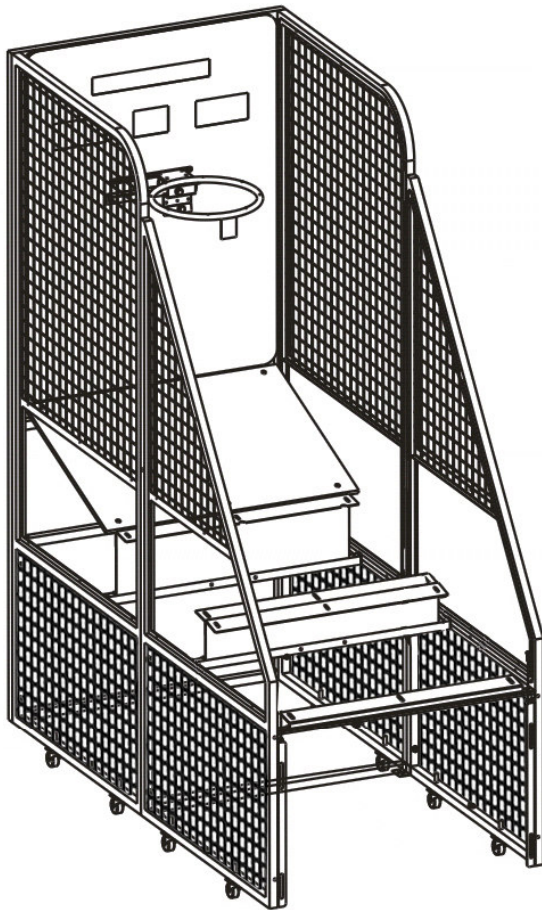

Ball holder kit

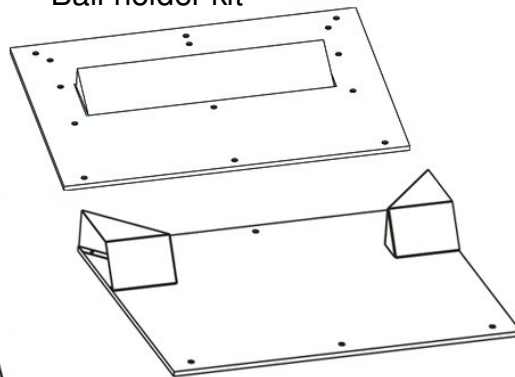

Ball guide kits

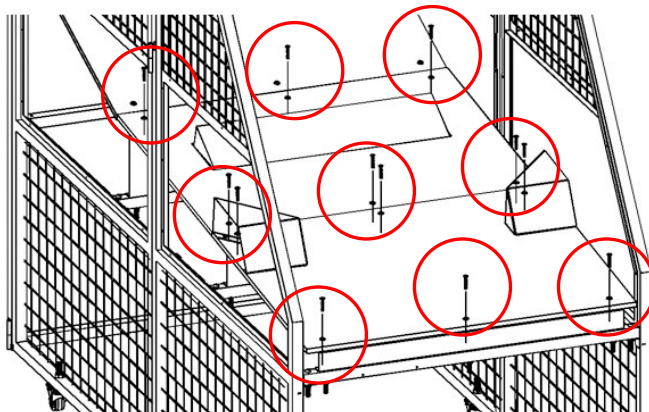

- P.34 NO. 11 screw (M6×26)×12
- P.35 NO. 20 nut (M6)×12
- P.35 NO. 30 washer(M6×26)×12



Step 4 :

1. Screw 【6A Ball net holder kit】 .
2. Screw 【6B Main part】 、 【Metal Shelf (optional)】 .

Assembly parts :

- 6A Ball net holder kit
- 6B Main part
- Metal Shelf (optional)

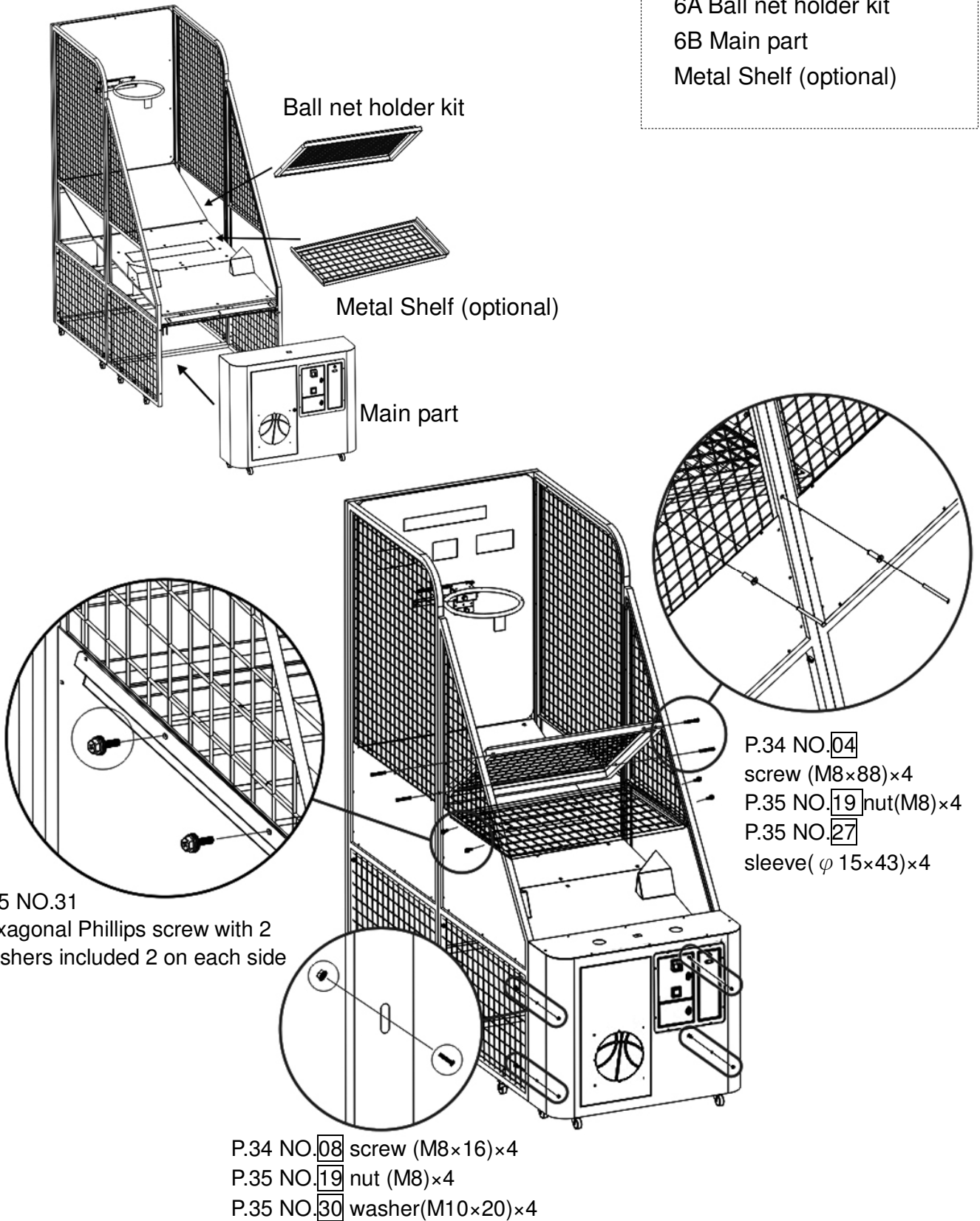



Step 5 :

1. Fix the 3 main cords as the following drawing.
2. Run the IC board plug and the ball holder kit plug located underneath the front of the ball net holder, through the hole in back of the main part.
3. Now connect plugs as shown in drawing.

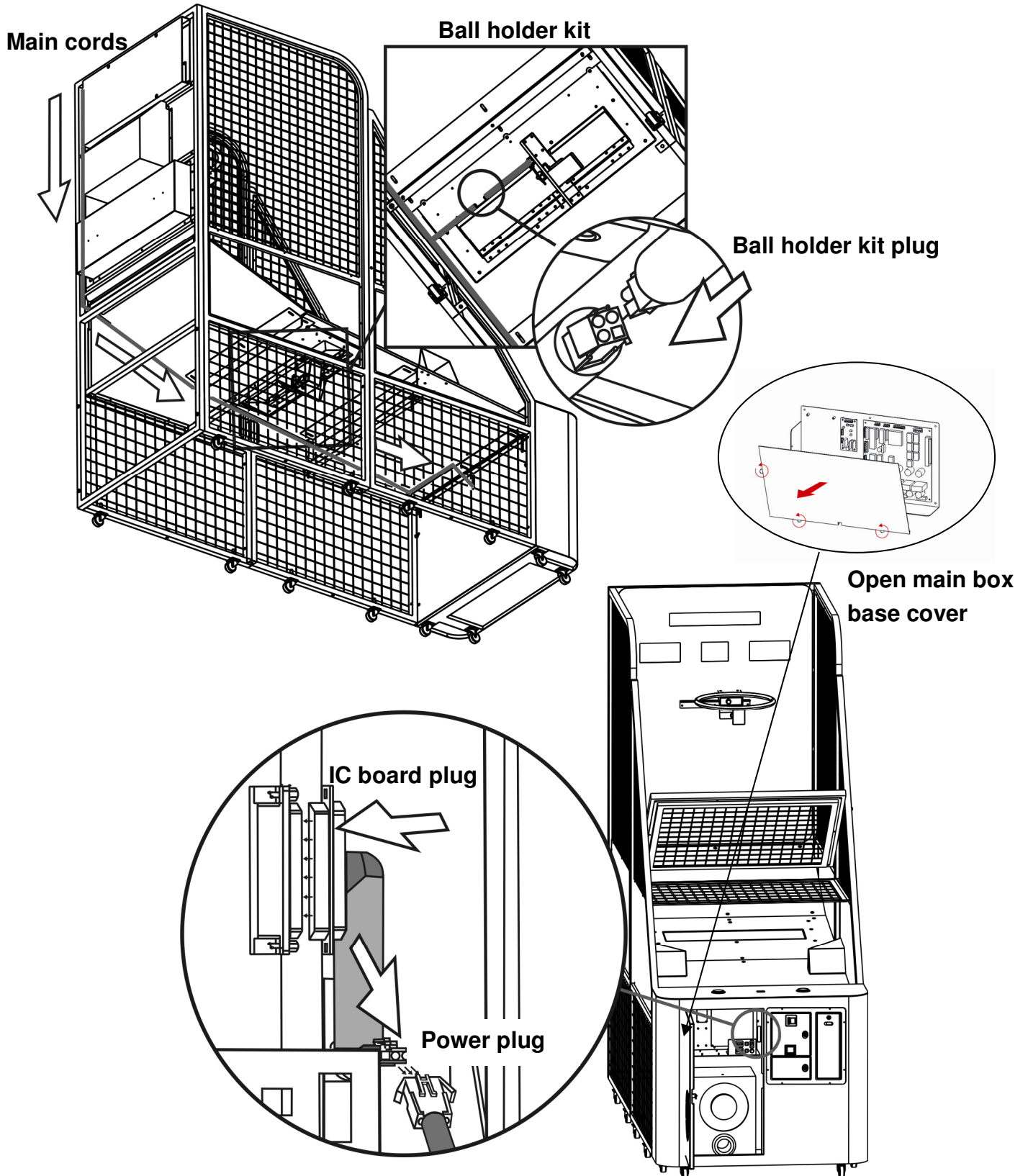



Step 6 :

Screw 【Top cover(optional)】 step by step as drawing.

Assembly parts

Top cover(optional)

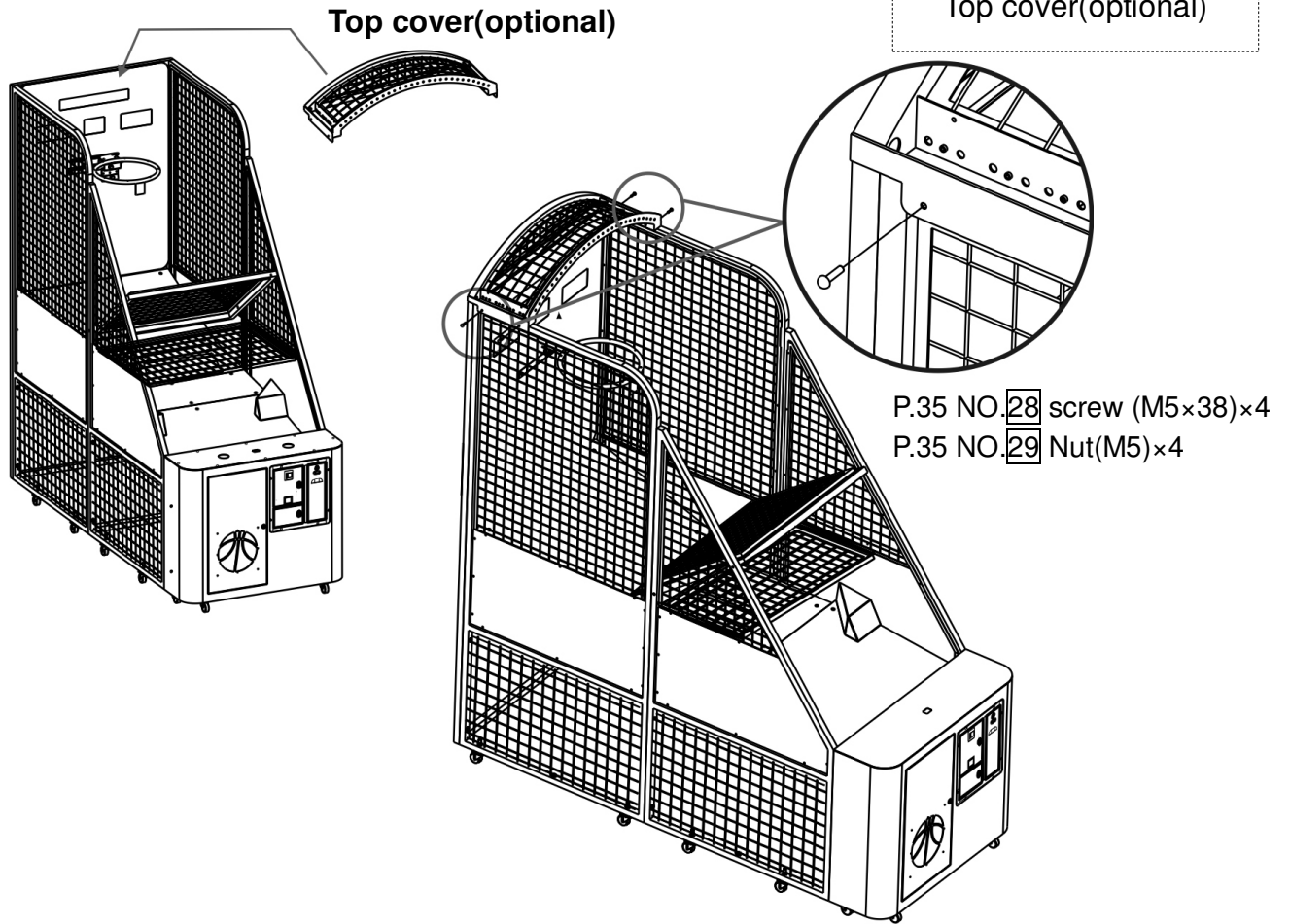

Step 7 :

1. connect the I/O control board with Top cover.
2. Now connect plugs as shown in drawing.

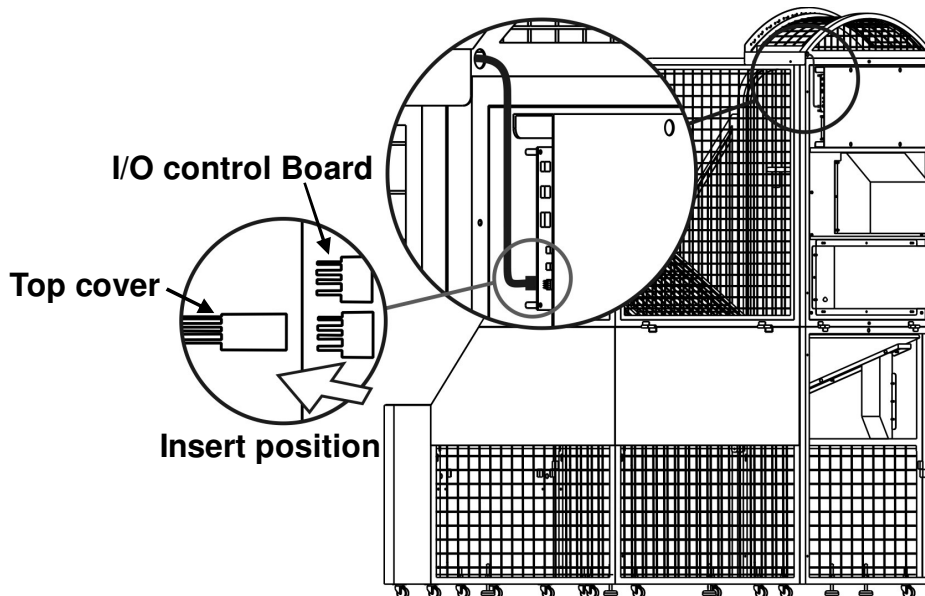



Step 8 :

Use screws to fix it then complete the assembly street basketball.

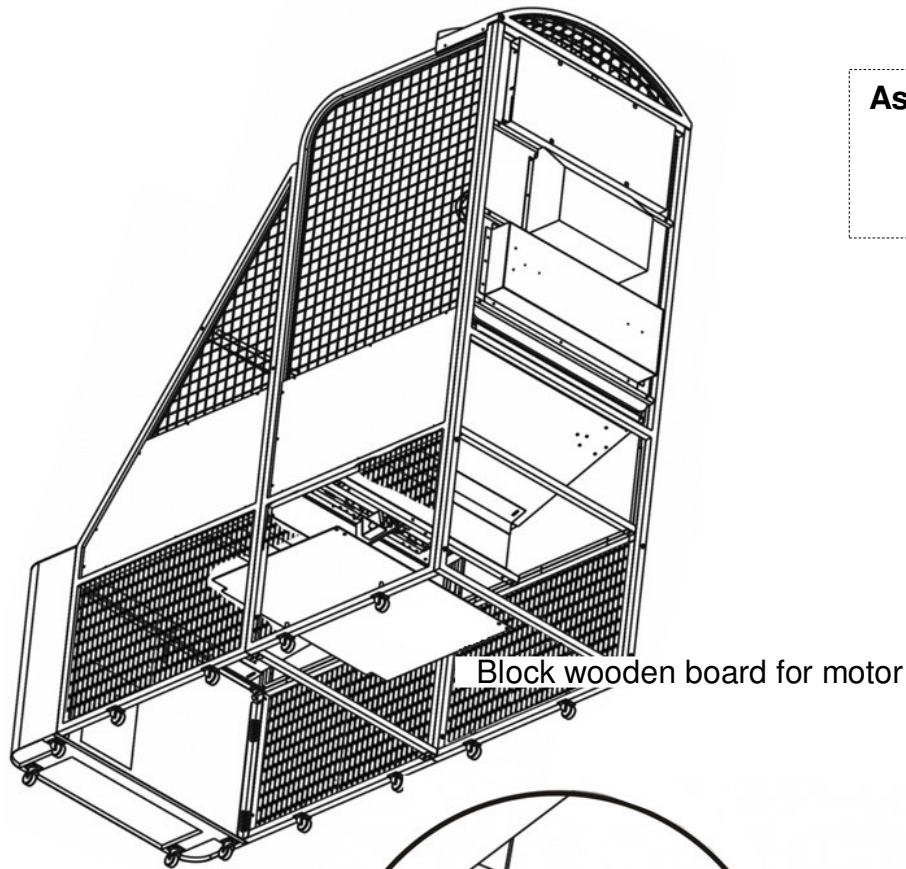

Assembly parts
6C Block wooden board
for motor

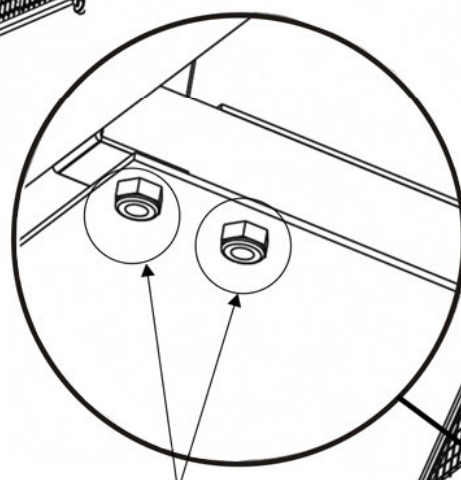

P.35 NO. 20 nut(M6)×4

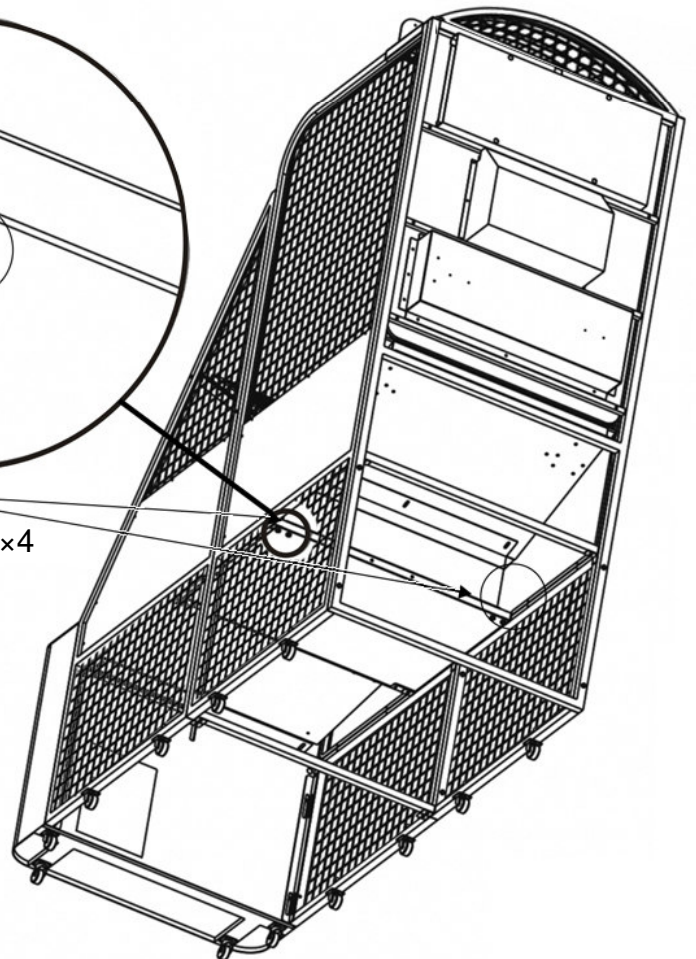

3. 【SET-UP Position & maintenance】

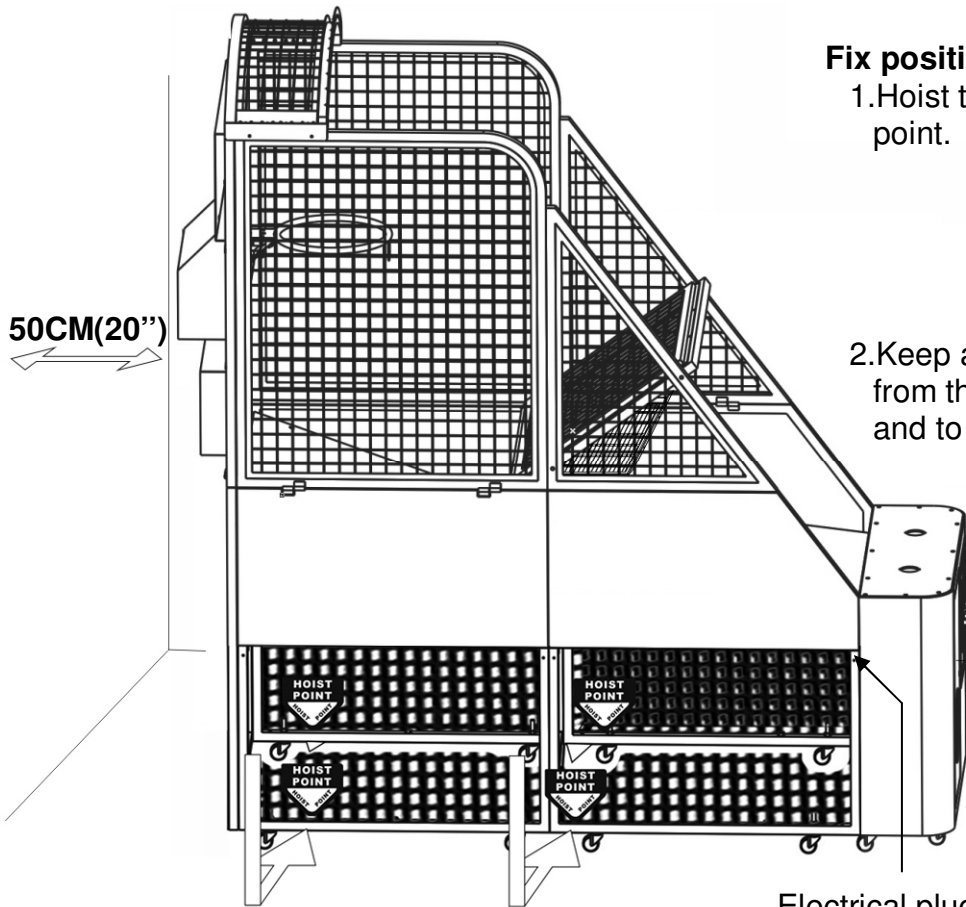

Fix position after assembly

1. Hoist the machine from the hoist point.



2. Keep at least 50cm(20") space from the back for maintenance and to avoid over heating.

Electrical plug display

ATTENTION

Attention:

- ⊙ The power must be turned off before any movements.
- ⊙ Check the power rate before use AC110V~120V/AC220V~240V, Check Electrical plug display as a guide.

V. Adjustment and Inspection

You can find the audit system by opening the main part door.

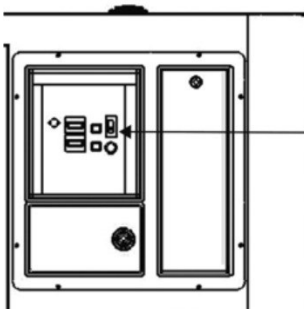

IC board includes power 、 fuse 、 audit and test functions

Please see 【 1 Link adjustment 】 for IC board function.

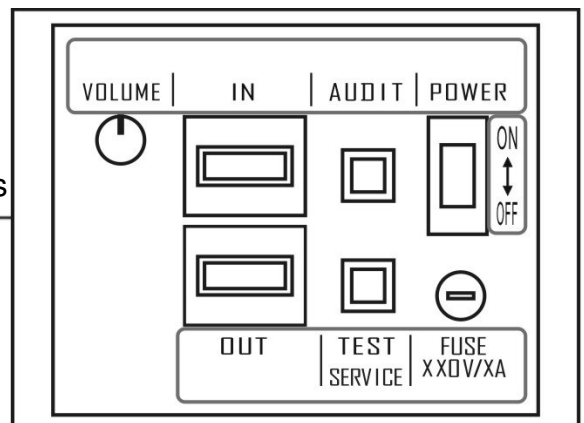

1.Link adjustment

【Cable link SET-UP】

The link set-up must follow DIP-SW-SEP-UP N0.1~15 machines.

Intermittent allowed, but cannot repeat.

- A . Link up to 15 machines
- B . Only one main frame is needed.
- C . Any game could be used as the main frame.

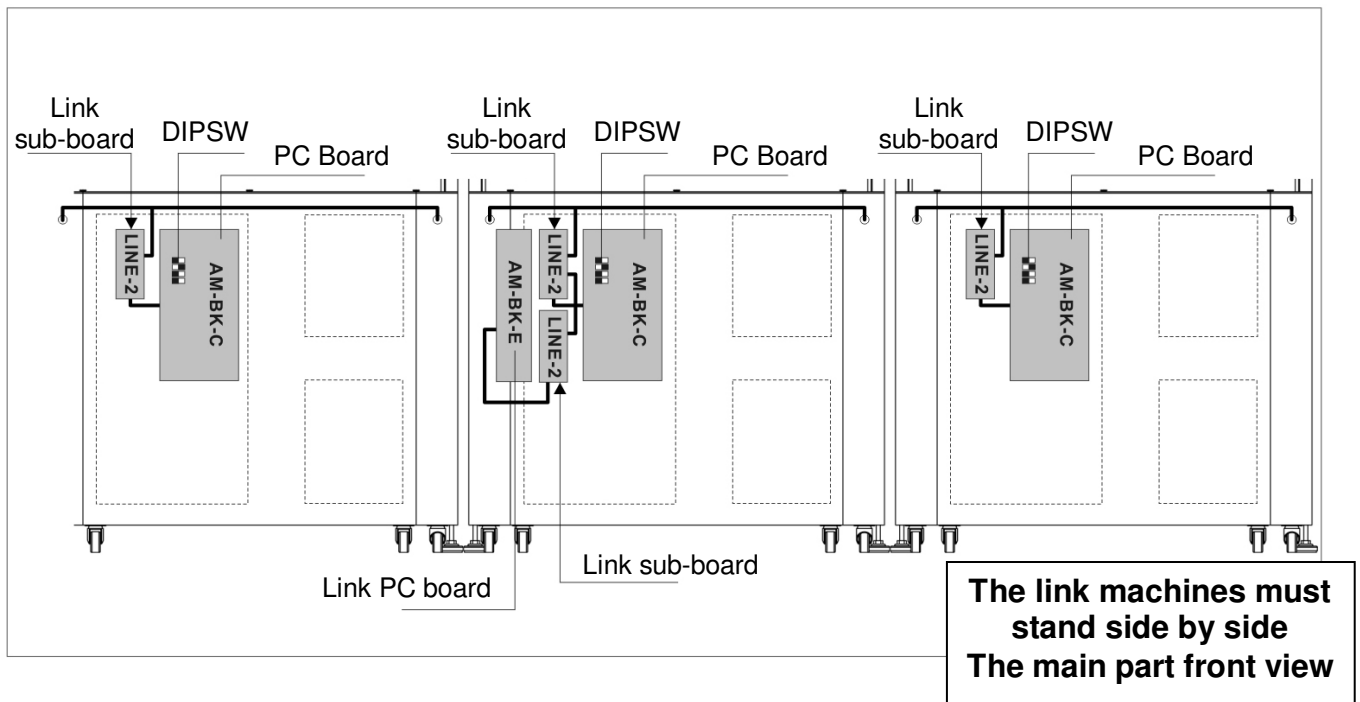
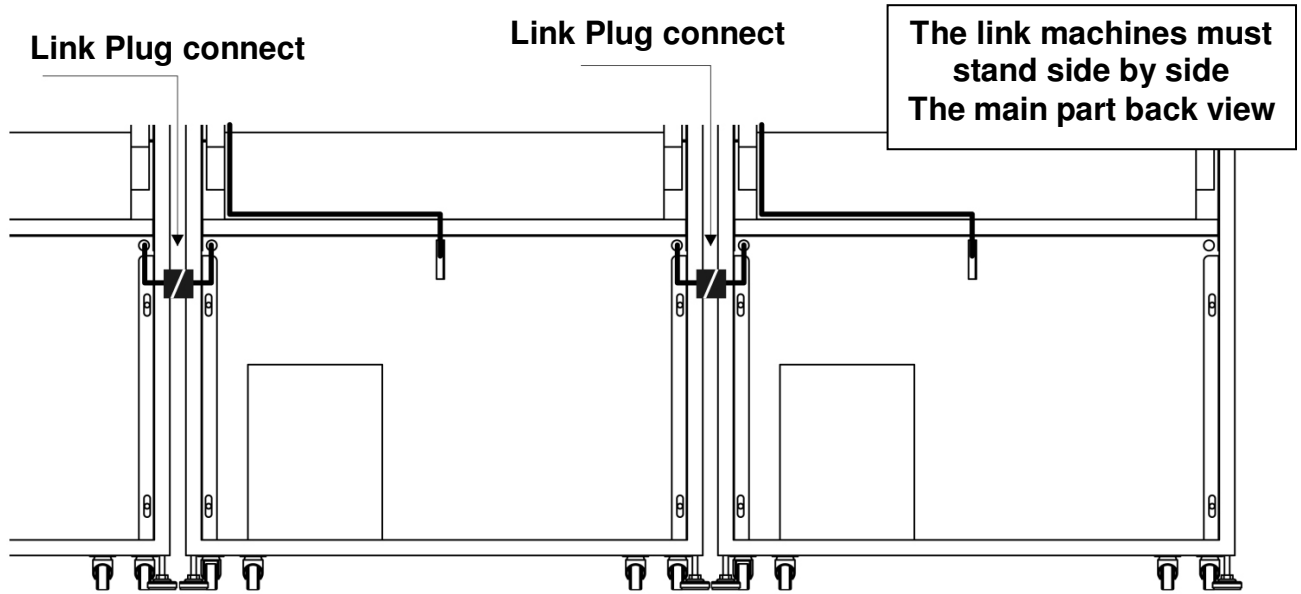



P.S. If two link machines-2 PCB are connected, the main control one DIP-SW must be set as OFF OFF OFF ON.

【Link main board adjustment】

Multi-function button :



1. Press and turn on the power, for 「TEST」 function.
2. In Standby mode  is 「SERVICE」 function, Press once means one coin, but No record.
3. In audit mode  is 「RESET」 function.
4. In ticket dispenser error mode, press  is 「Key out」 function.

Link DIP-SW adjustment :

SW4	SW3	SW2	SW1	
OFF	OFF	OFF	OFF	Single mode
OFF	OFF	OFF	ON	link 1 Unit
OFF	OFF	ON	OFF	link 2 Unit
OFF	OFF	ON	ON	link 3 Unit
OFF	ON	OFF	OFF	link 4 Unit
OFF	ON	OFF	ON	link 5 Unit
OFF	ON	ON	OFF	link 6 Unit
OFF	ON	ON	ON	link 7 Unit
ON	OFF	OFF	OFF	link 8 Unit
ON	OFF	OFF	ON	link 9 Unit
ON	OFF	ON	OFF	link 10 Unit
ON	OFF	ON	ON	link 11 Unit
ON	ON	OFF	OFF	link 12 Unit
ON	ON	OFF	ON	link 13 Unit
ON	ON	ON	OFF	link 14 Unit
ON	ON	ON	ON	link 15 Unit

Single mode starting display :

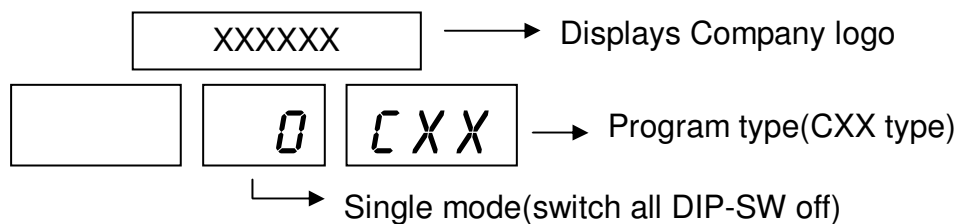

Link mode starting display :

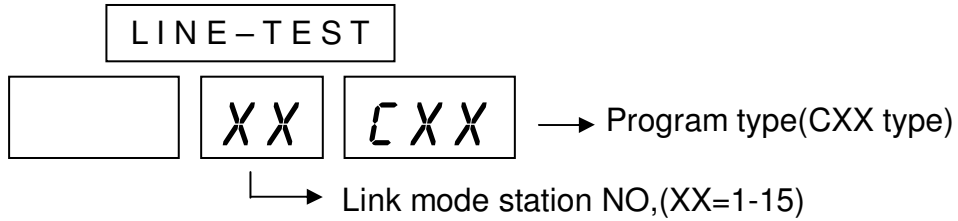

ATTENTION

When you turn on the main control machine, the other machines will link as set situation.



2.Adjustment

LINE-TEST after done the test can enter the set up.

Press  and turn on the power, release the key after you hear the sound.

【SET-UP 1】 SET-UP the coin entry price for each game

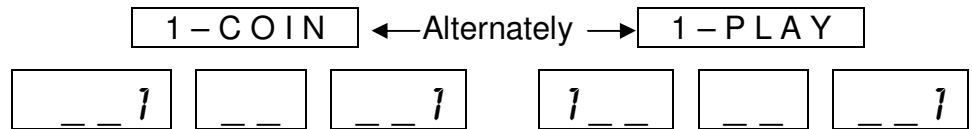

Press  then release

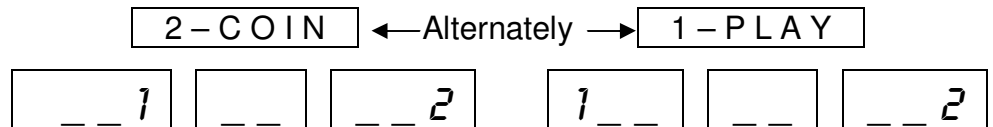

Press  then release

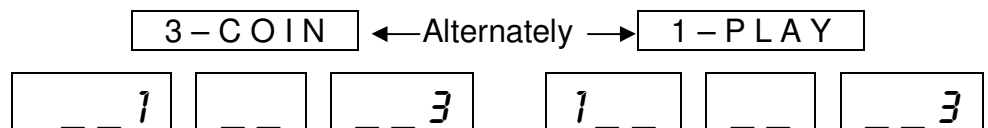

Press  then release

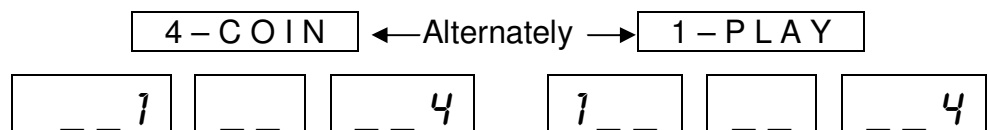

Press  for then release to enter SET-UP 2

【SET-UP 2】 Additional tickets

	MIN-OUT							
	<table border="1" style="display: inline-table; border-collapse: collapse;"> <tr><td style="width: 20px; height: 20px;"> </td><td style="width: 20px; height: 20px;"> </td><td style="width: 20px; height: 20px;"> </td></tr> <tr><td style="text-align: center;">2</td><td> </td><td style="text-align: center;">0</td></tr> </table>				2		0	0 ticket dispensed after every game is ended
2		0						
Press then release	<table border="1" style="display: inline-table; border-collapse: collapse;"> <tr><td style="width: 20px; height: 20px;"> </td><td style="width: 20px; height: 20px;"> </td><td style="width: 20px; height: 20px;"> </td></tr> <tr><td style="text-align: center;">2</td><td> </td><td style="text-align: center;">1</td></tr> </table>				2		1	Each time game over Release 1 additional tickets
2		1						
Press then release	<table border="1" style="display: inline-table; border-collapse: collapse;"> <tr><td style="width: 20px; height: 20px;"> </td><td style="width: 20px; height: 20px;"> </td><td style="width: 20px; height: 20px;"> </td></tr> <tr><td style="text-align: center;">2</td><td> </td><td style="text-align: center;">2</td></tr> </table>				2		2	Each time game over Release 2 additional tickets
2		2						
Press then release	<table border="1" style="display: inline-table; border-collapse: collapse;"> <tr><td style="width: 20px; height: 20px;"> </td><td style="width: 20px; height: 20px;"> </td><td style="width: 20px; height: 20px;"> </td></tr> <tr><td style="text-align: center;">2</td><td> </td><td style="text-align: center;">3</td></tr> </table>				2		3	Each time game over Release 3 additional tickets
2		3						
Press for 1 second then release to enter SET-UP 3								

【SET-UP 3】 Multiple of tickets

	TICKET							
	<table border="1" style="display: inline-table; border-collapse: collapse;"> <tr><td style="width: 20px; height: 20px;"> </td><td style="width: 20px; height: 20px;"> </td><td style="width: 20px; height: 20px;"> </td></tr> <tr><td style="text-align: center;">3</td><td> </td><td style="text-align: center;">00</td></tr> </table>				3		00	No ticket, game play only SET-UP 2 is ineffective.
3		00						
Press then release	<table border="1" style="display: inline-table; border-collapse: collapse;"> <tr><td style="width: 20px; height: 20px;"> </td><td style="width: 20px; height: 20px;"> </td><td style="width: 20px; height: 20px;"> </td></tr> <tr><td style="text-align: center;">3</td><td> </td><td style="text-align: center;">10</td></tr> </table>				3		10	10 points : 1 ticket
3		10						
Press then release	<table border="1" style="display: inline-table; border-collapse: collapse;"> <tr><td style="width: 20px; height: 20px;"> </td><td style="width: 20px; height: 20px;"> </td><td style="width: 20px; height: 20px;"> </td></tr> <tr><td style="text-align: center;">3</td><td> </td><td style="text-align: center;">20</td></tr> </table>				3		20	20 points : 1 ticket
3		20						
Press then release	<table border="1" style="display: inline-table; border-collapse: collapse;"> <tr><td style="width: 20px; height: 20px;"> </td><td style="width: 20px; height: 20px;"> </td><td style="width: 20px; height: 20px;"> </td></tr> <tr><td style="text-align: center;">3</td><td> </td><td style="text-align: center;">30</td></tr> </table>				3		30	30 points : 1 ticket
3		30						
Press then release	<table border="1" style="display: inline-table; border-collapse: collapse;"> <tr><td style="width: 20px; height: 20px;"> </td><td style="width: 20px; height: 20px;"> </td><td style="width: 20px; height: 20px;"> </td></tr> <tr><td style="text-align: center;">3</td><td> </td><td style="text-align: center;">40</td></tr> </table>				3		40	40 points : 1 ticket
3		40						
Press then release	<table border="1" style="display: inline-table; border-collapse: collapse;"> <tr><td style="width: 20px; height: 20px;"> </td><td style="width: 20px; height: 20px;"> </td><td style="width: 20px; height: 20px;"> </td></tr> <tr><td style="text-align: center;">3</td><td> </td><td style="text-align: center;">50</td></tr> </table>				3		50	50 points : 1 ticket
3		50						
Press then release	<table border="1" style="display: inline-table; border-collapse: collapse;"> <tr><td style="width: 20px; height: 20px;"> </td><td style="width: 20px; height: 20px;"> </td><td style="width: 20px; height: 20px;"> </td></tr> <tr><td style="text-align: center;">3</td><td> </td><td style="text-align: center;">60</td></tr> </table>				3		60	60 points : 1 ticket
3		60						



Press  then release

70 points : 1 ticket

Press  then release

80 points : 1 ticket

Press  then release

90 points : 1 ticket

Press  then release

100 points : 1 ticket

The explanation :

If the operator sets the game for 3___10 and the game is giving out tickets the player will receive 1 ticket for every 10 points scored . If the operator sets the game for 3___20 the player will get 1 ticket for every 20 points scored and so on.

For additional (0-3) tickets enter SET-UP 2

Press  for 1 second then release to enter SET-UP 4

【SET-UP 4】 Game Time SET-UP

GAME - TIME

Stage 1 : 50 seconds

Stage 2 : 40 seconds

Stage 3 : 30 seconds

Stage 4 : 20 seconds

Stage 1 : 55 seconds

Stage 2 : 45 seconds

Stage 3 : 35 seconds

Stage 4 : 25 seconds

Stage 1 : 60 seconds

Stage 2 : 50 seconds

Stage 3 : 40 seconds

Stage 4 : 30 seconds

Press  for 1 second then release to enter SET-UP 5

【SET-UP 5】 Basket motor AUTO test

STE-MOT-1

__ 5 __ __

Press  then release-Start basketball motor AUTO test
(Warning alarm will start after 5 seconds, if there is an error)

Press  for 1 second then release to enter SET-UP 6

【SET-UP 6】 Ball holder motor AUTO test

STE-MOT-2

__ 6 __ __

Press  then release-Start ball holder motor AUTO test
(Warning alarm will start after 5 seconds, if there is an error)

Press  for 1 second then release to enter SET-UP 7

【SET-UP 7】 Reset the top score 250 or keep the record

XXXXXX → Displays Company logo

__ 7 __ __ Reset the top score to 250

Press  then release

XXXXXX → Displays Company logo

__ 7 __ 7 Keep the record

Press  then release to enter SET-UP 8

【SET-UP 8】 SET-UP DEMO music (ON or OFF)

XXXXXX → Displays Company logo

__ 8 __ __ DEMO music OFF

Press then release

XXXXXX → Displays Company logo

__ 8 **__** **__ 1** DEMO music ON

✳Restart the Machine to complete the SET-UP adjustment.

3.LED Monitor inspection

Testing :

1. Press and turn on the power at the same time to enter LED testing mode.
Release the test button after it displays "1" on the LED.
2. Check if the LED is displayed correctly.
3. When testing is finished you will enter the standby mode.

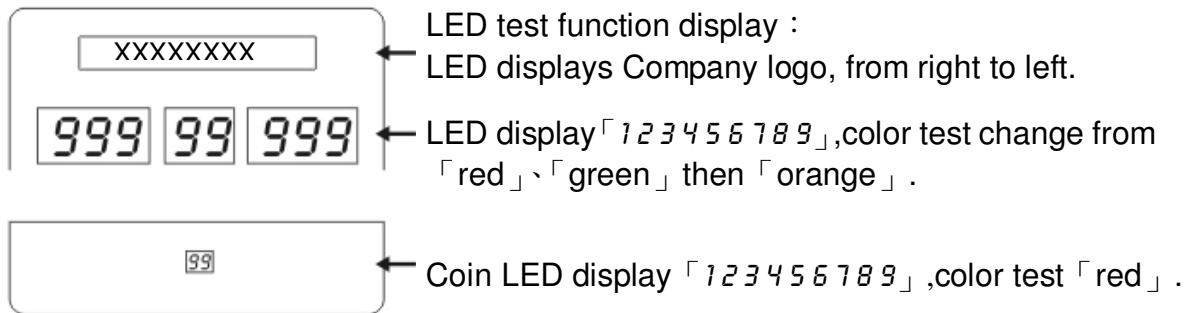

4. After AUTO test is finished, it will enter standby mode.

4.AUDIT

Press enter audit system in standby function only.

Press then release, enter **【audit 1】**

COUNT - IN
1CX **XX** **XXX**

Record total received
Coins up to 999999 same as counter,
counter reset is not allowed.

Press then release, enter **【audit 2】**

COUNT - OUT
2CX **XX** **XXX**

Record total dispensed tickets
Tickets up to 999999 same as counter,
counter reset is not allowed.

Press then release, enter **【audit 3】**

SHIFT - IN

3CX XX XXX

Record total received
Coins up to 999999,
counter reset is allowed.

Press then release, enter **【audit 4】**

SHIFT - OUT

3CX XX XXX

Record total dispensed tickets
up to 999999,
counter reset is allowed.

Press then release, return back to audit function **【The end】**

XXXXXX → Displays Company logo

55

※Press then release, enter into standby function.

※Press then release, return back to **【audit 3】** function. And reset the **【audit 3】** and **【audit 4】** .

5.Error code

Every time machine is turned on it will do the AUTO test for 7 function points, before entering standby mode.

The Error specification as below,

【Error 1】 **COIN-1**

Warning alarm action
Left coin selector is disconnected
Left coin selector didn't turn in to NC
Left coin selector error

【Error 2】 **COIN-2**

Warning alarm action
Right coin selector is disconnected
Right coin selector didn't turn in to NC
Right coin selector error

【Error 3】 **SET-MOT-1**

Warning alarm action
Basket motor power is disconnected
Basket SENSOR-NO
Basket is out of position

<p>【Error 4】 SET-MOT – 2</p>	<p>Warning alarm action Ball holder motor power is disconnected Ball holder SENSOR-NO Ball holder is out of position</p>
<p>【Error 5】 T I C K E T</p>	<p>Warning alarm action Ticket dispenser is disconnected Ticket dispenser adjustment error No tickets Press  for clean tickets.</p>
<p>【Error 6】 COUNT - IN</p>	<p>Warning alarm action Coin counter is disconnected Coin counter error</p>
<p>【Error 7】 COUNT-OUT</p>	<p>Warning alarm action Ticket counter is disconnected Ticket counter error</p>

VI.How to play

1.There are total 4 Stages

- A.Stage 1 : Proceed to Stage 2,when the total scores are over 40 in the end.
- B.Stage 2 : Proceed to Stage 3,when the total scores are over 150 in the end.
- C.Stage 3 : Proceed to Stage 4,when the total scores are over 250 in the end.
- D.Stage 4 : Final challenge, the last game will be finished when the time is terminated.

2.2 play types available

- A.Single play : DIP-SW set to single play.
- B.Link mode : DIP-SW set to link mode, up to 15 machines can be linked.
 Press link mode, display link countdown time, any other machine can be linked together during the countdown. In link mode, up to 15 machines can be linked.

When the machine is in standby mode, the SW is ineffectual.



VII.Screw and Nut list

NO	picture	Specification	Total quantity	Position
1		screw(M4×12)	68	set
2		screw (M4×10)	21	set
3		screw (M3×5)	26	set
4		screw(M8×88)	4	Knock down machine Step 7 Semi-assemble machine Step 4
5		screw (M5×20)	8	set
6		screw (M5×20)	8	set
7		screw (M5)	4	set
8		screw(M8×16)	4	Knock down machine Step 7 Semi-assemble machine Step 4
9		screw (M6×55)	1	set
10		screw (M6×48)	14 12	Knock down machine Step 3.5.6 Semi-assemble machine Step 2
11		screw (M6×26)	20 14	Knock down machine Step 5.6 Semi-assemble machine Step 2.3
12		screw (M6×16)	16	set
13		screw (M5×15)	6	Knock down machine Step 2
14		screw (M4×15)	4	set
15		screw (M4×12)	58	set
16		screw (M4×8)	8	set
17		screw (M3×12)	2	set

NO	picture	Specification	Total quantity	Position
18		screw (M3×10)	1	set
19		nut(M8)	16	Knock down machine Step 4.7
			12	Semi-assemble machine Step 1.4
20		nut (M6)	38	Knock down machine Step 3.5.6.11
			20	Semi-assemble machine Step 2.3.8
21		nut (M5)	6	Knock down machine Step 2
22		nut (M4)	20	set
23		nut (M6)	4	set
24		nut (M5)	8	set
25		nut (M4)	44	set
26		nut (M3)	7	set
27		sleeve (φ 15×43)	4	Knock down machine Step 7
				Semi-assemble machine Step 4
28		screw (M5×38)	4	Knock down machine Step 9
				Semi-assemble machine Step 6
29		washer(M4×12)	4	Knock down machine Step 9
				Semi-assemble machine Step 6
30		washer (M6.5×13.5)	24	Knock down machine Step 6.7
			12	Semi-assemble machine Step 3.4
31		Hexagonal Phillips screw will 2 Washers	4	Knock down machine Step 7
				Semi-assemble machine Step 4
32		screw (M4×10)	48	Knock down machine Step 1
33		screw (M8×70)	8	Knock down machine Step 3.4
			4	Semi-assemble machine Step 1

VIII. Wires Layout

Basketball Wire diagram

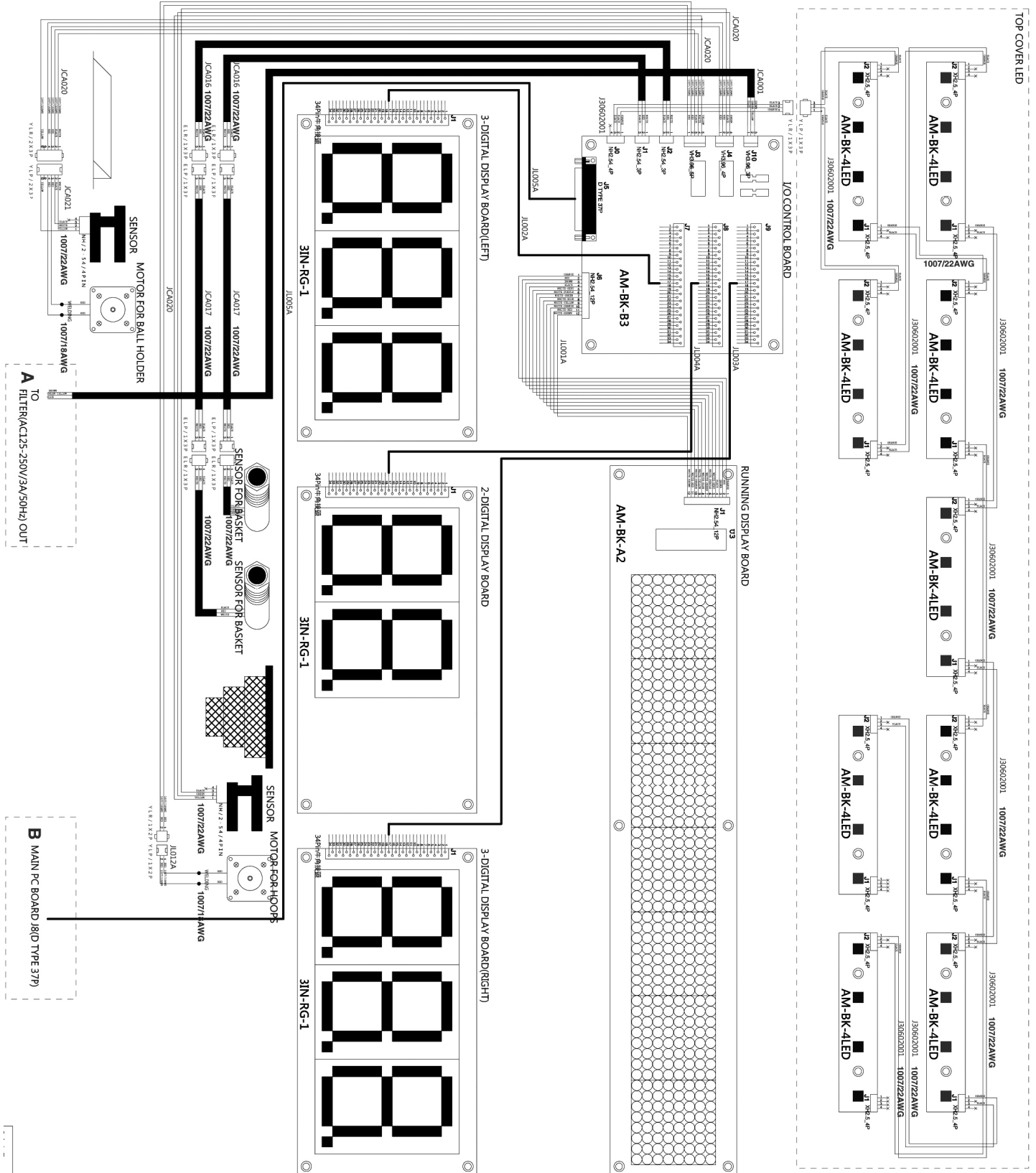

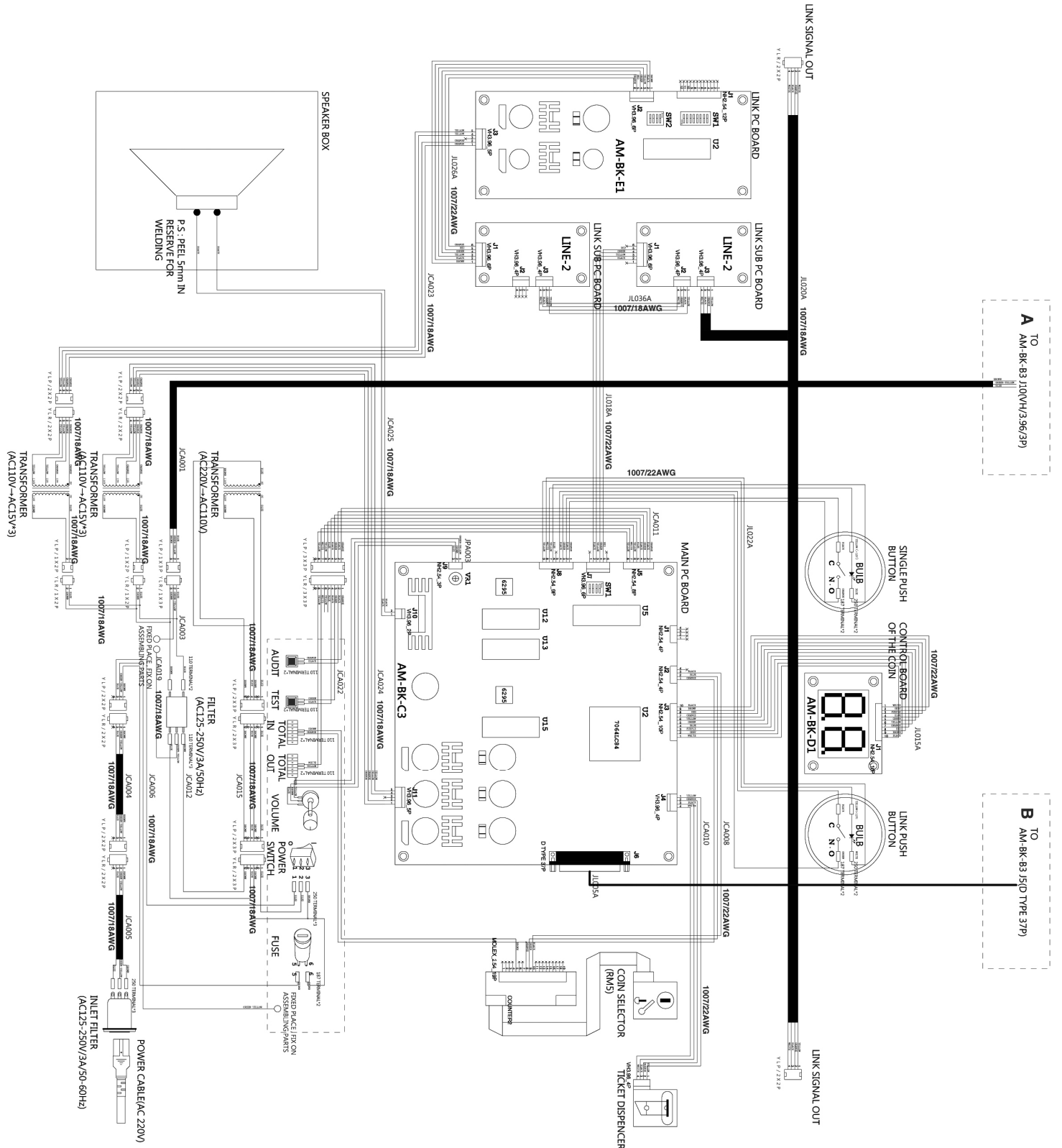

IX.Expanded view

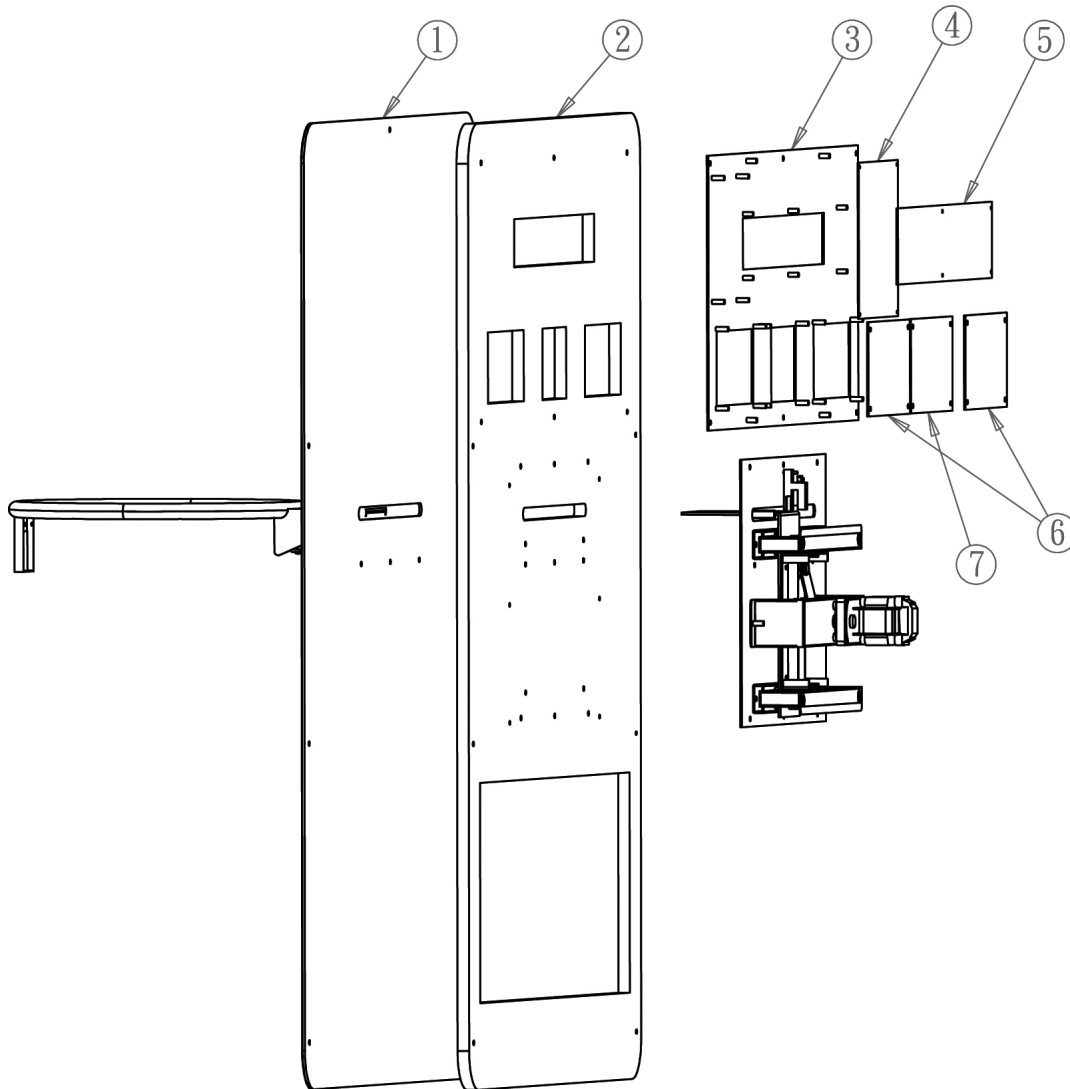

Item	Name	Part Number	Quantity
1	Basket acrylic board (Namco)	88401072	1
2	Wooden basket board	88401073	1
3	Main wooden board	88407074	1
4	I/O control board	88401001	1
5	Running display board	88401003	1
6	3 Digital display board	88401008	2
7	2 Digital display board	88401007	1

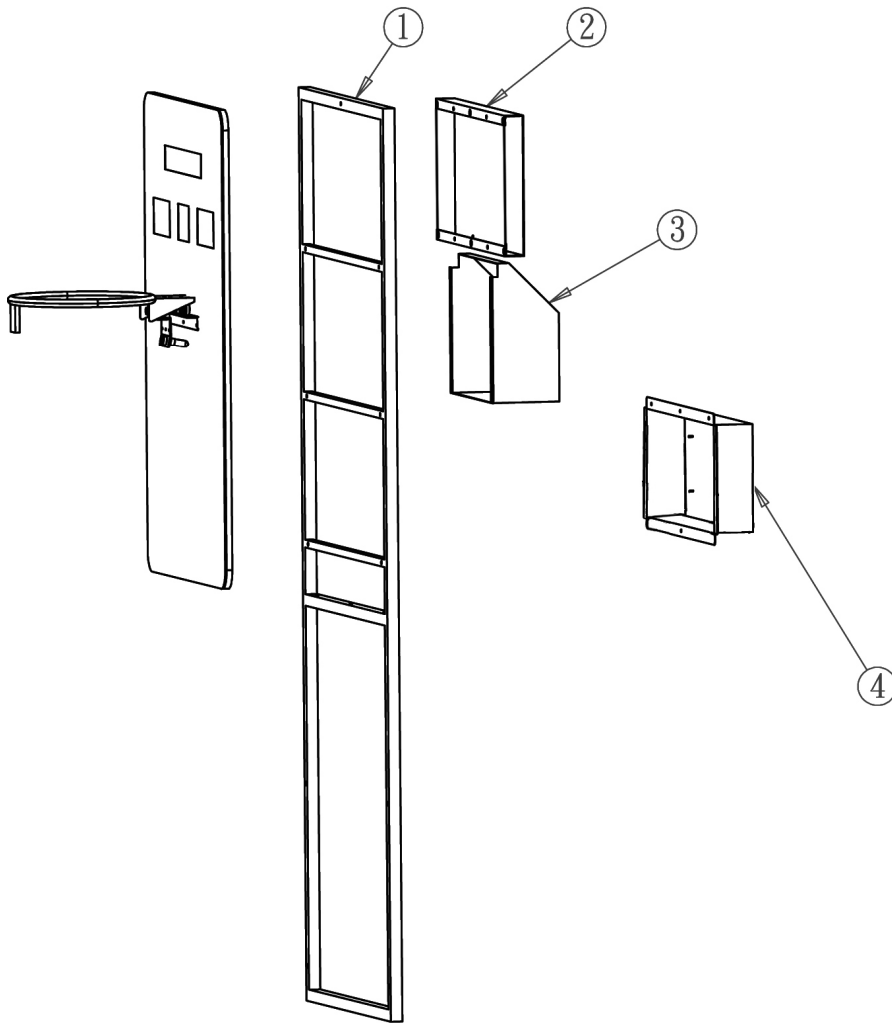

Item	Name	Part Number	Quantity
1	Frame for main wooden board fix use	88401013	1
2	Board cover	88401014	1
3	Basket cover	88401015	1
4	Box cover	88401016	1

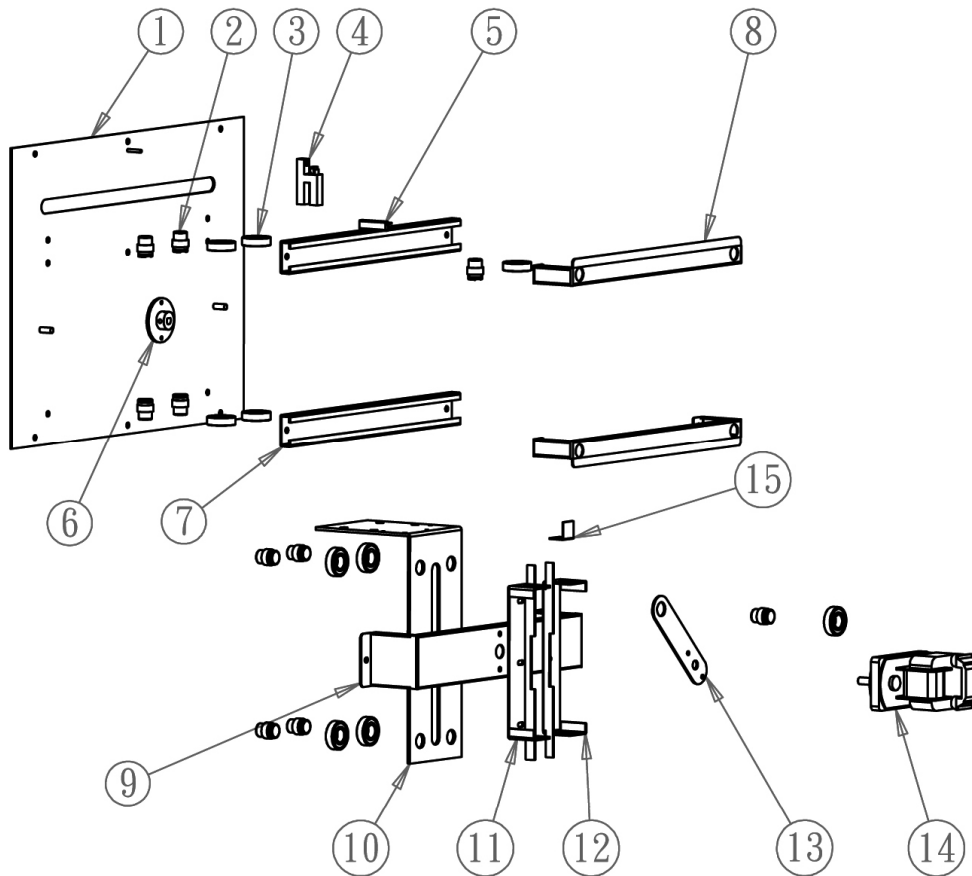

Item	Name	Part Number	Quantity
1	Wooden board for basket unit fix use	88401017	1
2	Bearing	88401018	9
3	Bearing (6002ZZ)	88401019	9
4	Sensor 1.1	88401002	1
5	Sliding railway for sensor	88401020	1
6	Bearing D-Type for Basket	88401021	1
7	Sliding railway for basket	88401022	2
8	Bearing cover	88401023	2
9	Basket motor holder	88401024	1
10	Basket holder	88401025	1
11	Basket left holder	88401026	1
12	Basket right holder	88401027	1
13	Connecting rod for basket unit	88401028	1
14	Gear motor (KGB-215-8130B1)	88401006	1
15	Basket position board	88401029	1

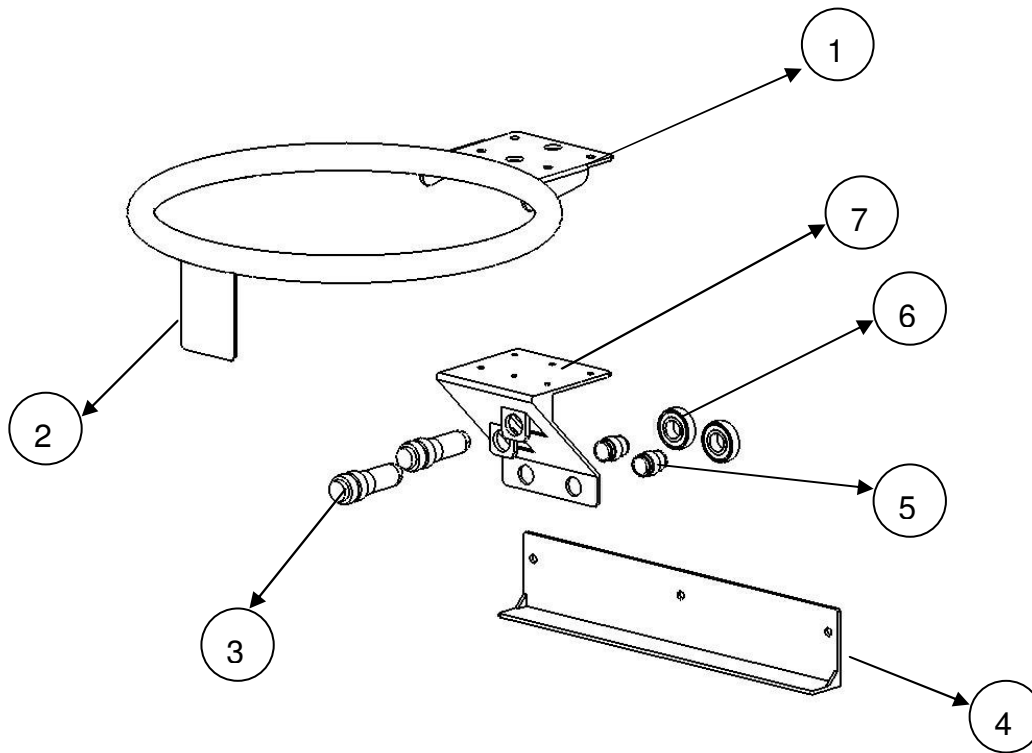

Item	Name	Part Number	Quantity
1	Basket net kit	88401030	1
2	3M reflection sticker	88401031	1
3	Sensor for basket (WO-RNPW2)	88401005	2
4	Basket sensor railway	88401032	1
5	Bearing	88401018	2
6	Bearing (6002ZZ)	88401019	2
7	Holder for basket sensor	88401033	1

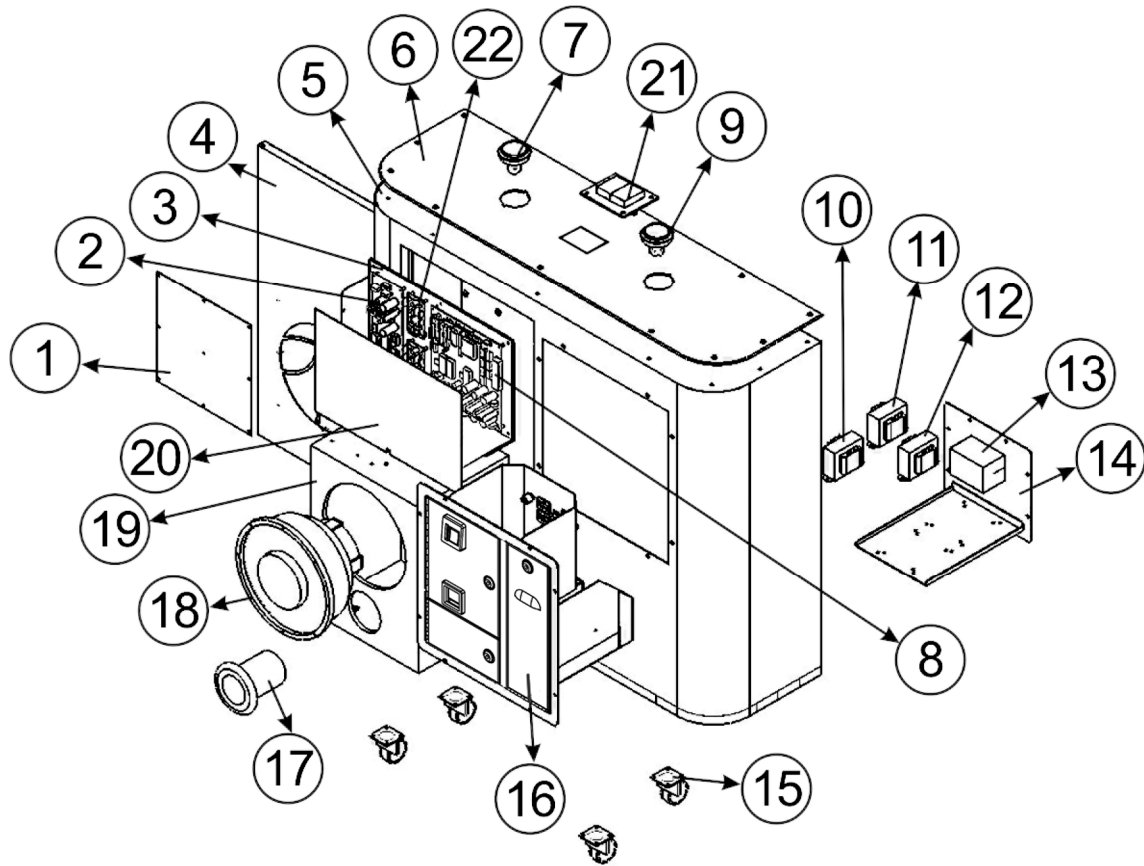

Item	Name	Part Number	Quantity
1	Hole type cover	88401034	1
2	Link IC Board (AM-BK-E1)(RoHS)	88401000	1
3	Main box base	88401035	1
4	The door of speaker	88401036	1
5	Main part (Namco)	88401037	1
6	Main part acrylic board (Namco)	88401038	1
7	1P playpush button	88401009	1
8	Single main IC board	88401010	1
9	2P playpush button	88401009	1
10	Transformer 220V/110V 2A	88401039	1
11	Transformer 110V/15V 3A*2	88401040	1
12	Transformer 110V/15V 3A*2	88401040	1
13	The knob for wooden box	88401041	1
14	Base for transformer fixed use	88401042	1
15	Castor	88401043	4
16	3 in 1 door (Namco)(UK)	88401044	1
17	Ventilation duct of speaker box	88401045	1
18	Speaker	88401046	1
19	Speaker box	88401047	1
20	Cover for IC board (Namco)	88401048	1
21	Coin display board	88401004	1
22	Link Sub IC Board(Namco)(LINE-2)	88401011	2

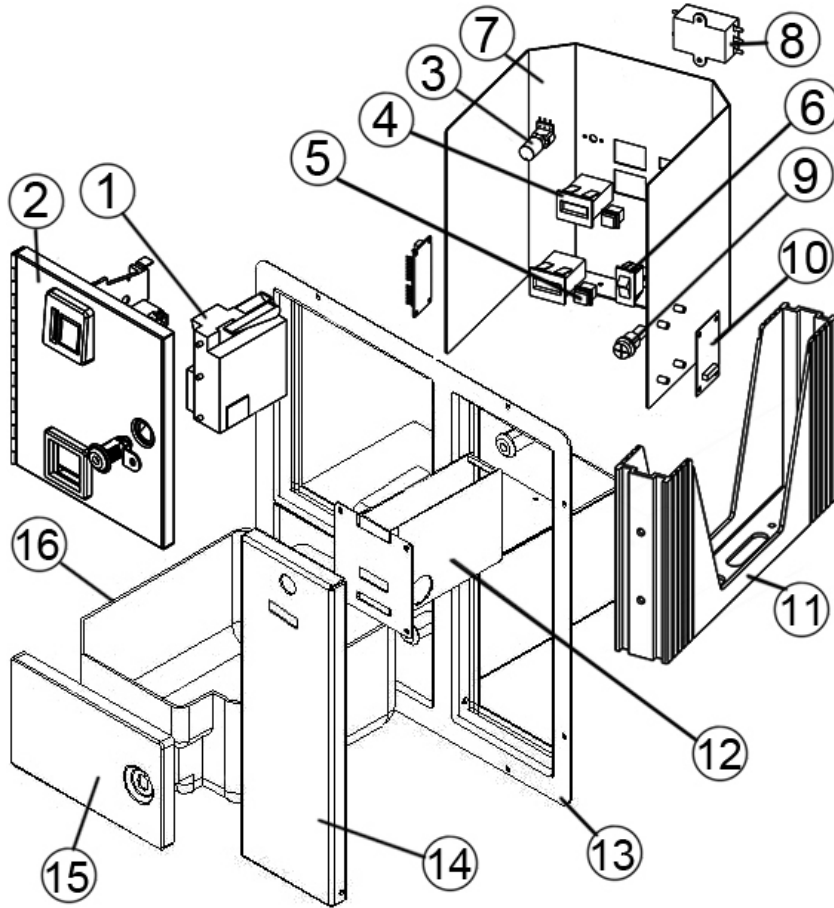

Item	Name	Part Number	Quantity
1	Coin selector – RM5	88401012	1
2	Coin door with hinge (Namco UK)	88401049	1
3	Variable resistor 10K 3p	88401050	1
4	Counter	88401051	2
5	Audit push button (Red)	88401052	2
6	Ship-Type switch	88401053	1
7	Socket for counter (Namco)	88401054	1
8	Filter YG03T5 (3A)	88401055	1
9	Fuse R3-11 20mm	88401056	1
10	Ticket control board	88401057	1
11	Ticket container	88401058	1
12	Ticket dispenser((DL-1275)SA	67000004	1
13	Frame of 3 in 1	88401059	1
14	Ticket door with hinge	88401061	1
15	Cash box door with hinge	88401062	1
16	Cash box	88401063	1

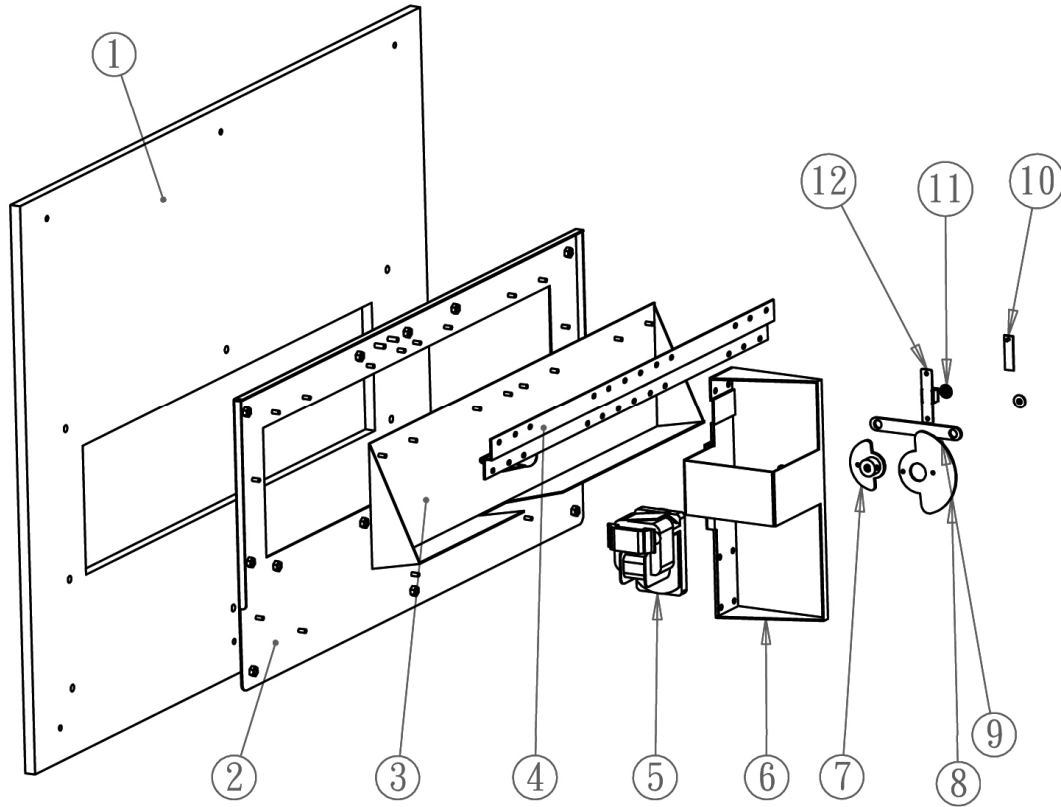

Item	Name	Part Number	Quantity
1	Wooden board B-type	88401064	1
2	Base of ball holder unit	88401065	1
3	Ball holder kit	88401066	1
4	Hinge for ball holder (650*46.6)	88401067	1
5	Gear Motor KGB-215-6130B1	88401006	1
6	Motor Frisked for ball holder kit	88401068	1
7	Bearing D-Type for ball holder	88401069	1
8	Ball holder bearing	88401070	1
9	Arm of ball holder	88401071	1
10	Sensor 1.1	88401002	1



PAC-MANTM
BASKET

