

## Table of Contents

JEDI Main Wiring Diagram .....	Sheet 1B
JEDI Color Raster Power Supply Wiring Diagram .....	Sheet 2A
JEDI Game Interfaces .....	Sheet 2B
Coin Door	
Utility Panel	
Fluorescent Light	
Regulator/Audio II PCB Schematic .....	Sheet 3A
JEDI Memory Maps .....	Sheet 3B
JEDI Game PCB Schematic .....	Sheets 4A-11B
PIXI II PCB Schematic .....	Sheet 12A

## Schematic Package Supplement to

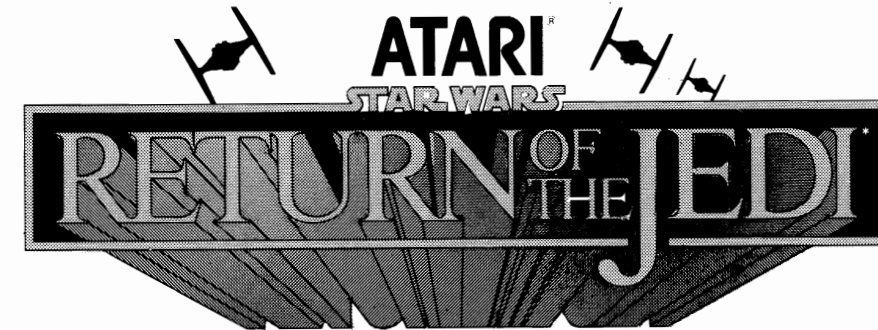

## Operators Manual

**NOTE**

This staple temporarily holds the schematic package together. Remove the staple before using these schematics.

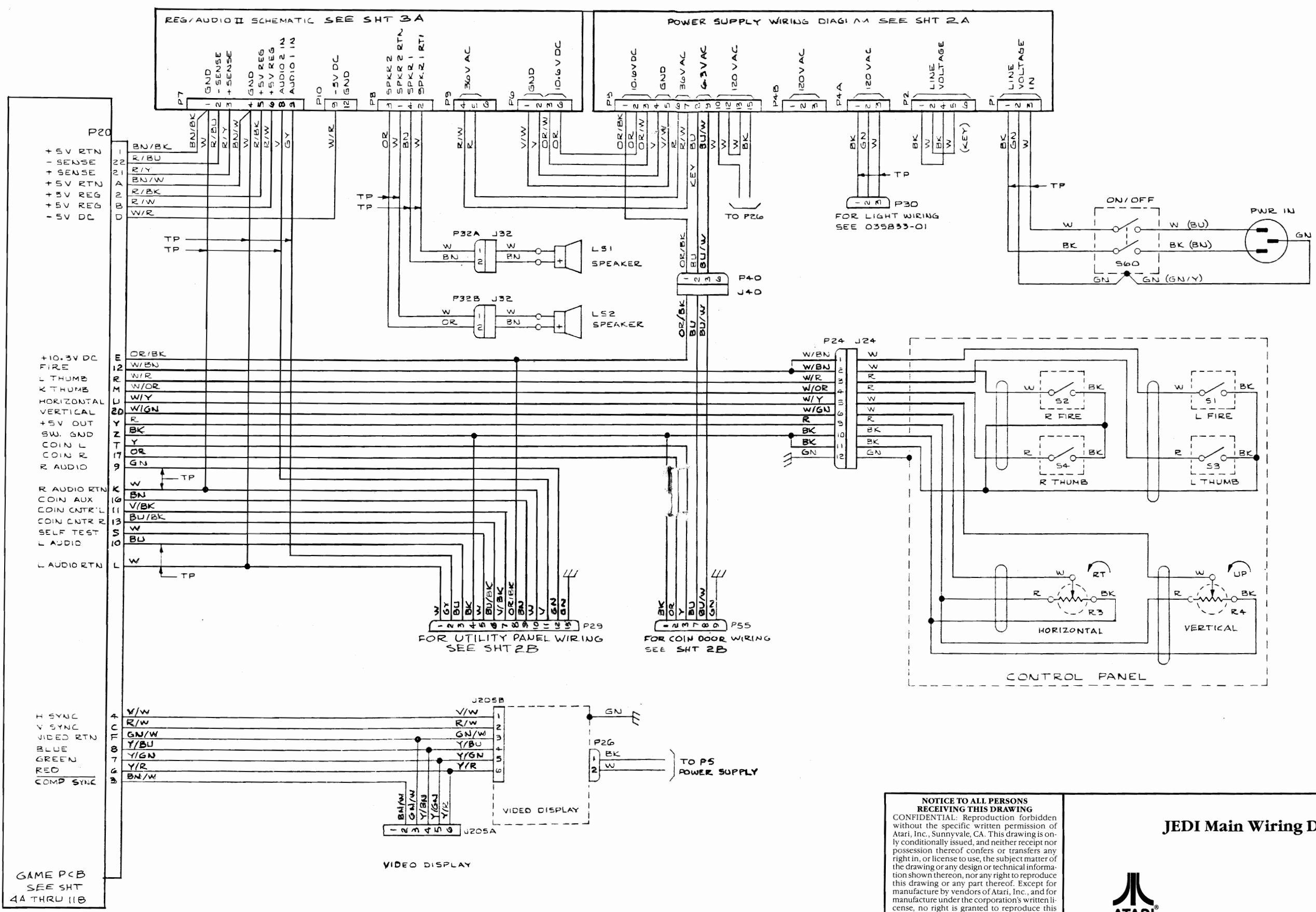

### JEDI Main Wiring Diagram



A Warner Communications Company

© ATARI INC. 1984

SP-227 Sheet 1B  
1st printing

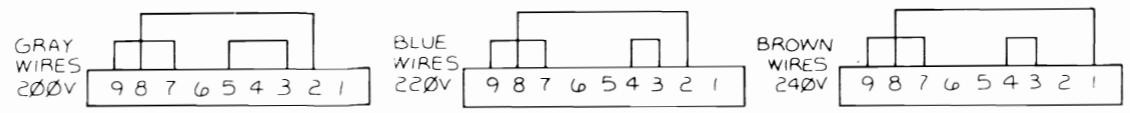

VOLTAGE SELECTION BLOCKS

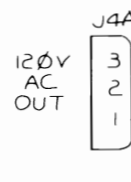
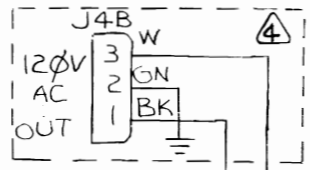
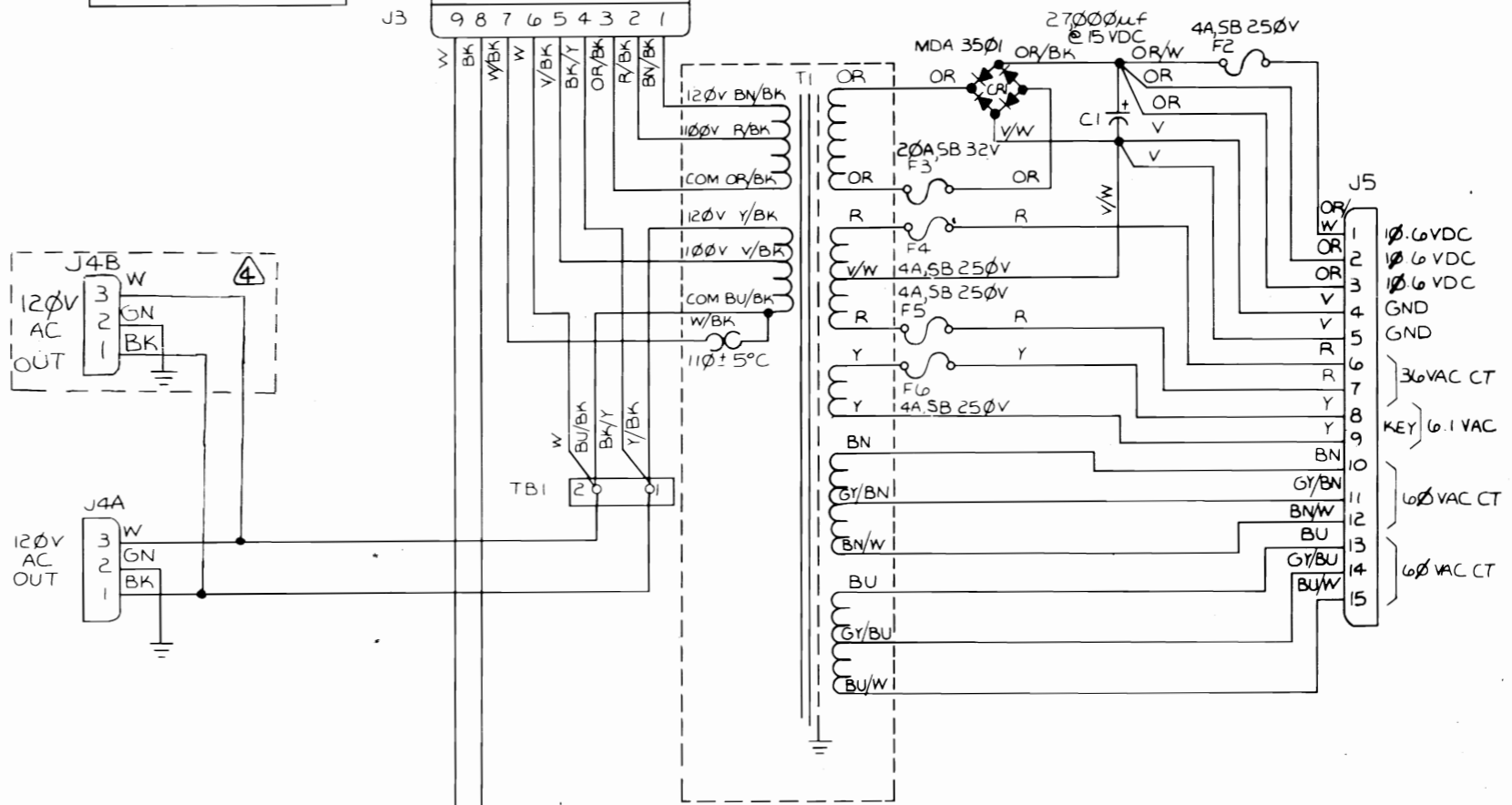
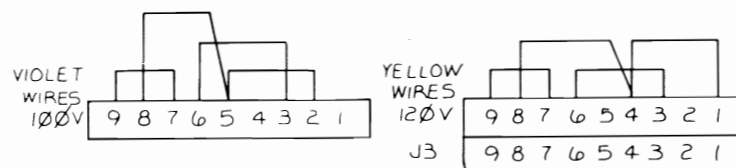

- NOTES:
- ③ USE 25 AMP, 5B 32V FUSE AT F3 FOR -04, -05 & -06 VERSION OF A037671-XX POWER SUPPLY.
  - ④ J4-B USED IN -07 THROUGH -12 VERSION OF A037671-XX POWER SUPPLY ASSY.
  - ⚠ POWER CORD ASSY MAY HAVE WIRE COLORS AS SHOWN OR WIRE COLORS AS FOLLOWS: ONE BLACK WIRE (AC), ONE GREEN WIRE (GND) AND ONE WHITE WIRE (NEUTRAL).
  - ⚠ USE 4 AMP, 5B 250V FUSE AT F1 WITH 220V & 240V (EUROPEAN ONLY)

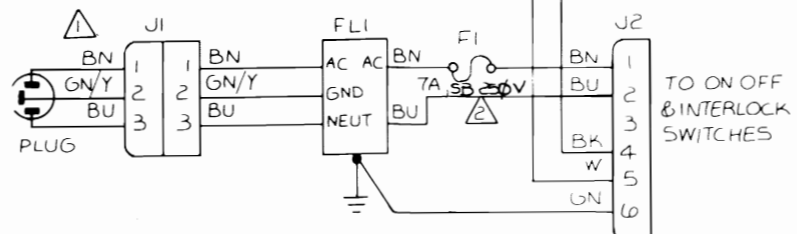

**NOTICE TO ALL PERSONS RECEIVING THIS DRAWING**  
 CONFIDENTIAL: Reproduction forbidden without the specific written permission of Atari, Inc., Sunnyvale, CA. This drawing is only conditionally issued, and neither receipt nor possession thereof confers or transfers any right in, or license to use, the subject matter of the drawing or any design or technical information shown thereon, nor any right to reproduce this drawing or any part thereof. Except for manufacture by vendors of Atari, Inc., and for manufacture under the corporation's written license, no right is granted to reproduce this drawing or the subject matter thereof, unless by written agreement with or written permission from the corporation.

**Power Supply Schematic**

SP-227 Sheet 2A  
1st printing

© ATARI INC. 1984  
A Warner Communications Company

### Coin Door Wiring Diagram

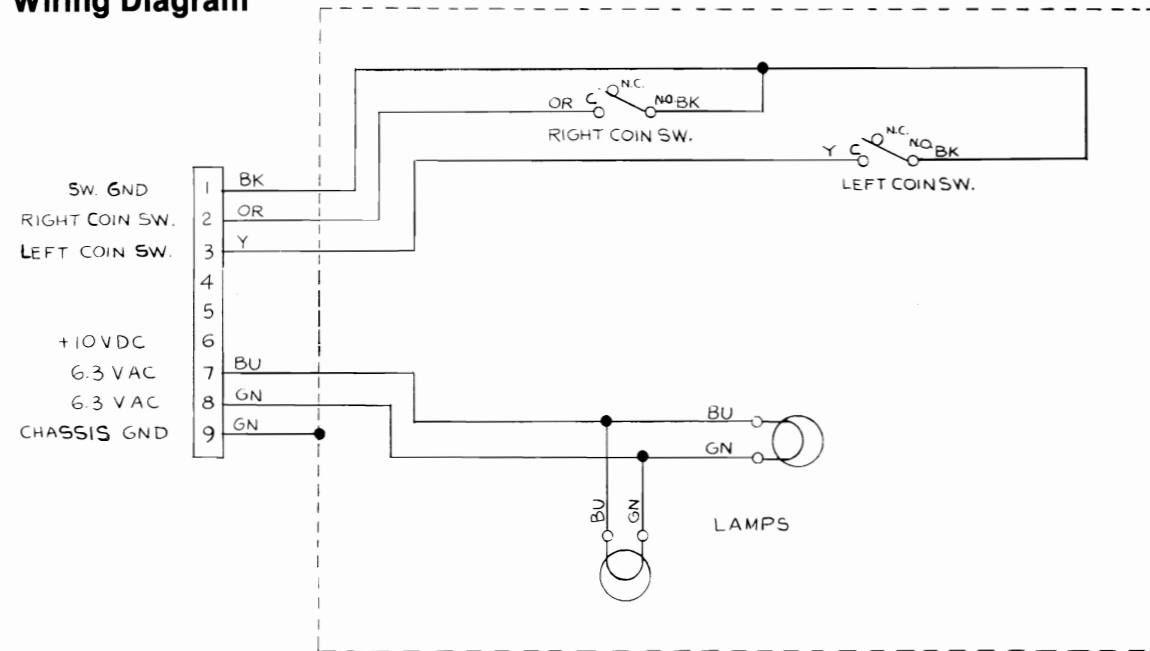

### Fluorescent Light Wiring Diagram

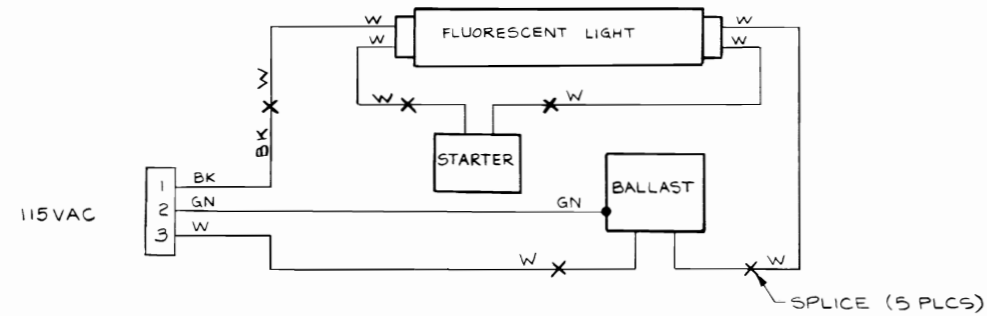

### Utility Panel Wiring Diagram

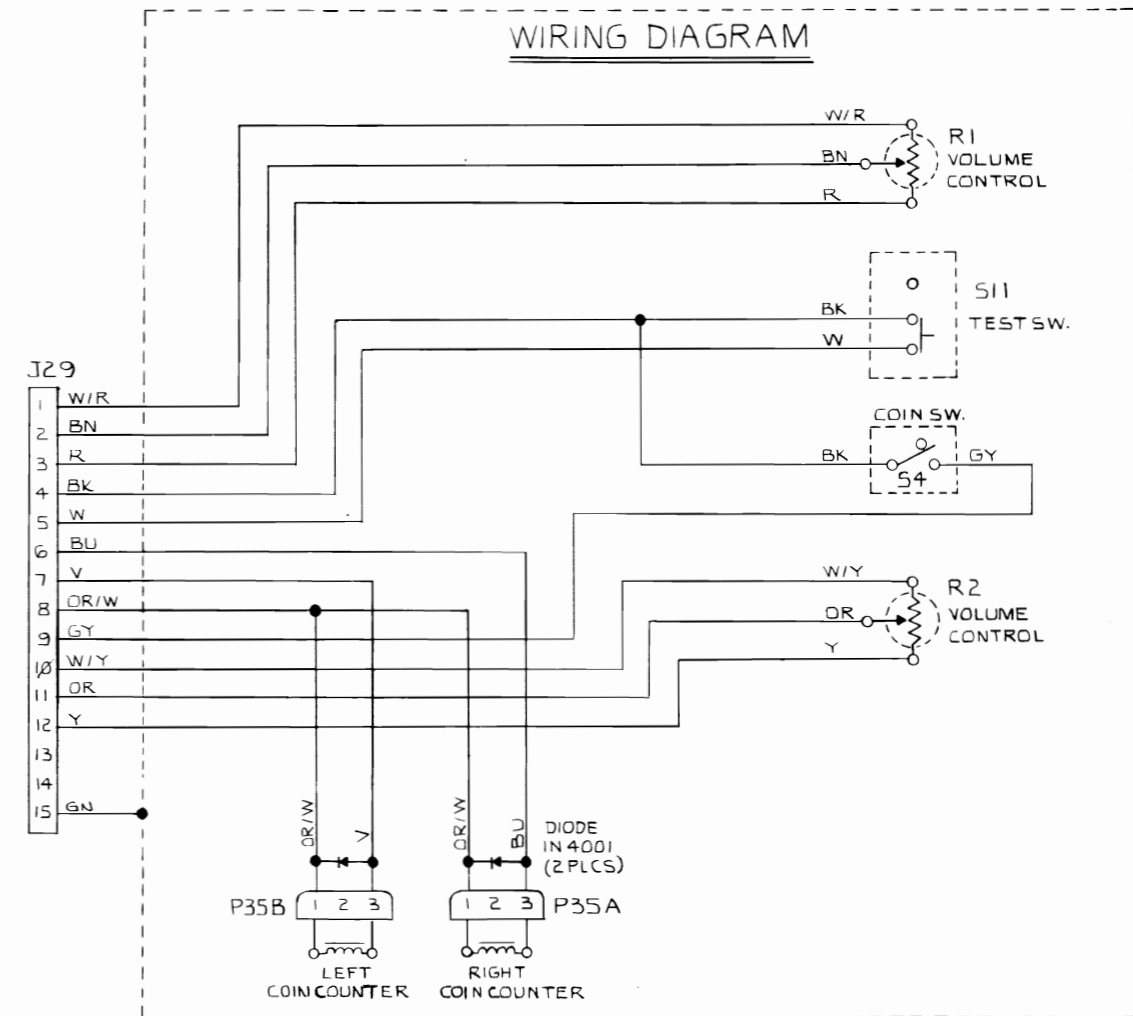

#### NOTICE TO ALL PERSONS RECEIVING THIS DRAWING

CONFIDENTIAL: Reproduction forbidden without the specific written permission of Atari, Inc., Sunnyvale, CA. This drawing is only conditionally issued, and neither receipt nor possession thereof confers or transfers any right in, or license to use, the subject matter of the drawing or any design or technical information shown thereon, nor any right to reproduce this drawing or any part thereof. Except for manufacture by vendors of Atari, Inc., and for manufacture under the corporation's written license, no right is granted to reproduce this drawing or the subject matter thereof, unless by written agreement with or written permission from the corporation.

#### JEDI Game Interfaces



A Warner Communications Company

© ATARI INC. 1984

SP-227 Sheet 2B  
1st printing

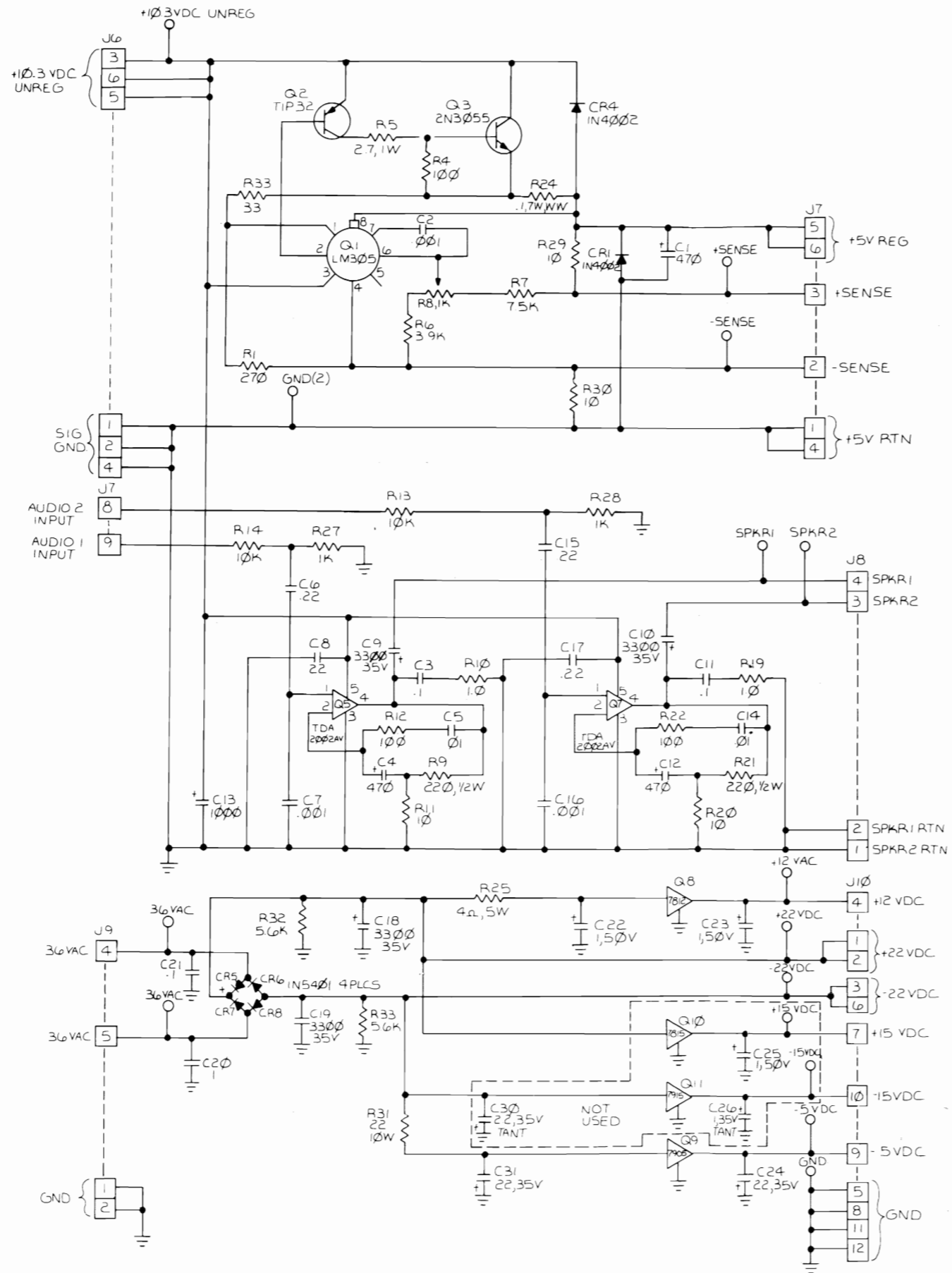

**NOTICE TO ALL PERSONS RECEIVING THIS DRAWING**  
 CONFIDENTIAL: Reproduction forbidden without the specific written permission of Atari, Inc., Sunnyvale, CA. This drawing is only conditionally issued, and neither receipt nor possession thereof confers or transfers any right in, or license to use, the subject matter of the drawing or any design or technical information shown thereon, nor any right to reproduce this drawing or any part thereof. Except for manufacture by vendors of Atari, Inc., and for manufacture under the corporation's written license, no right is granted to reproduce this drawing or the subject matter thereof, unless by written agreement with or written permission from the corporation.

**Regulator/Audio II PCB Schematic**

  
 A Warner Communications Company

© ATARI INC. 1984  
 SP-227 Sheet 3A  
 1st printing

## RETURN OF THE JEDI Memory Map (Main CPU Board)

HEXA-DECIMAL ADDRESS	ADDRESS BUS SIGNAL LINES																READ/ WRITE	DATA BUS SIGNAL LINES								FUNCTION
	A15	A14	A13	A12	A11	A10	A9	A8	A7	A6	A5	A4	A3	A2	A1	A0		D7	D6	D5	D4	D3	D2	D1	D0	
0000-07FF	0	0	0	0	0	A	A	A	A	A	A	A	A	A	A	A	R/W	D	D	D	D	D	D	D	D	Z-page working RAM
0800-08FF	0	0	0	0	1	0			A	A	A	A	A	A	A	A	R/W	D	D	D	D	D	D	D	D	Non-volatile RAM
0C00	0	0	0	0	1	1											0	R	D							Right coin switch
0C00	0	0	0	0	1	1											0	R		D						Left coin switch
0C00	0	0	0	0	1	1											0	R		D						Auxiliary coin switch
0C00	0	0	0	0	1	1											0	R			D					Self-test switch
0C00	0	0	0	0	1	1											0	R				D				Spare
0C00	0	0	0	0	1	1											0	R				D				Left thumb switch
0C00	0	0	0	0	1	1											0	R					D			Fire switches
0C00	0	0	0	0	1	1											0	R						D		Right thumb switch
0C01	0	0	0	0	1	1											1	R	D							VBLANK
0C01	0	0	0	0	1	1											1	R		D						Sound CPU communication latch full flag
0C01	0	0	0	0	1	1											1	R			D					Sound CPU acknowledge latch flag
0C01	0	0	0	0	1	1											1	R				D				Not used
0C01	0	0	0	0	1	1											1	R					D			Not used
0C01	0	0	0	0	1	1											1	R					D			Slam switch
0C01	0	0	0	0	1	1											1	R					D			Not used
0C01	0	0	0	0	1	1											1	R						D		Not used
1400	0	0	0	1	0	1											R	D	D	D	D	D	D	D	D	Sound CPU acknowledge latch
1800	0	0	0	1	1	0											R	D	D	D	D	D	D	D	D	Read A/D conversion
1C00	0	0	0	1	1	1	0	0	0								0	W								Enable non-volatile RAM
1C01	0	0	0	1	1	1	0	0	0								1	W								Disable non-volatile RAM
1C80	0	0	0	1	1	1	0	0	1					0	0	0	W									Start A/D conversion (horizontal)
1C82	0	0	0	1	1	1	0	0	1					0	1	0	W									Start A/D conversion (vertical)
1D00	0	0	0	1	1	1	0	1	0								W									Non-volatile RAM store
1D80	0	0	0	1	1	1	0	1	1								W									Watchdog clear
1E00	0	0	0	1	1	1	1	0	0								W									Interrupt acknowledge
1E80	0	0	0	1	1	1	1	0	1					0	0	0	W	D								Left coin counter
1E81	0	0	0	1	1	1	1	0	1					0	0	1	W	D								Right coin counter
1E82	0	0	0	1	1	1	1	0	1					0	1	0	W	D								LED 1 (not used)
1E83	0	0	0	1	1	1	1	0	1					0	1	1	W	D								LED 2 (not used)
1E84	0	0	0	1	1	1	1	0	1					1	0	0	W	D								Alphanumerics bank select
1E85	0	0	0	1	1	1	1	0	1					1	0	1	W	D								Not used
1E86	0	0	0	1	1	1	1	0	1					1	1	0	W	D								Sound CPU reset
1E87	0	0	0	1	1	1	1	0	1					1	1	1	W	D								Video off
1F00	0	0	0	1	1	1	1	1	0								W	D	D	D	D	D	D	D	D	Sound CPU communication latch
1F80	0	0	0	1	1	1	1	1	1								W					D	D	D	D	Program ROM bank select
2000-23FF	0	0	1	0	0	0	A	A	A	A	A	A	A	A	A	A	R/W	D	D	D	D	D	D	D	D	Scrolling playfield (low)
2400-27FF	0	0	1	0	0	1	A	A	A	A	A	A	A	A	A	A	R/W				D	D	D	D	D	Scrolling playfield (high)
2800-2BFF	0	0	1	0	1	0	A	A	A	A	A	A	A	A	A	A	R/W	D	D	D	D	D	D	D	D	Color RAM (low)
2C00-2FFF	0	0	1	0	1	1	A	A	A	A	A	A	A	A	A	A	R/W				D	D	D	D	D	Color RAM (high)
3000-37FF	0	0	1	1	0	A	A	A	A	A	A	A	A	A	A	A	R/W	D	D	D	D	D	D	D	D	Alphanumerics RAM
3800-3BFF	0	0	1	1	1	0	A	A	A	A	A	A	A	A	A	A	R/W	D	D	D	D	D	D	D	D	Motion object RAM
37C0-37EF	0	0	1	1	0	1	1	1	1	1	A	A	A	A	A	A	R/W	D	D	D	D	D	D	D	D	Motion object picture
3800-382F	0	0	1	1	1	0	0	0	0	0	A	A	A	A	A	A	R/W		D				D	D		Motion object picture bank select
3800-382F	0	0	1	1	1	0	0	0	0	0	A	A	A	A	A	A	R/W			D						Motion object vertical reflect
3800-382F	0	0	1	1	1	0	0	0	0	0	A	A	A	A	A	A	R/W				D					Motion object horizontal reflect
3800-382F	0	0	1	1	1	0	0	0	0	0	A	A	A	A	A	A	R/W					D				Motion object 32 pixels tall
3800-382F	0	0	1	1	1	0	0	0	0	0	A	A	A	A	A	A	R/W						D			Motion object horizontal position (D8)
3840-386F	0	0	1	1	1	0	0	0	0	1	A	A	A	A	A	A	R/W	D	D	D	D	D	D	D	D	Motion object vertical position
38C0-38EF	0	0	1	1	1	0	0	0	1	1	A	A	A	A	A	A	R/W	D	D	D	D	D	D	D	D	Motion object horizontal position (D7-D0)
3C00-3C01	0	0	1	1	1	1	0	0									D	W	D	D	D	D	D	D	D	Scrolling playfield vertical position
3D00-3D01	0	0	1	1	1	1	0	1									D	W	D	D	D	D	D	D	D	Scrolling playfield horizontal position
3E00-3FFF	0	0	1	1	1	1	A	A	A	A	A	A	A	A	A	A	W	D	D	D	D	D	D	D	D	PIXI graphics expander RAM
4000-7FFF	0	1	A	A	A	A	A	A	A	A	A	A	A	A	A	A	R	D	D	D	D	D	D	D	D	Banked program ROM
8000-FFFF	1	A	A	A	A	A	A	A	A	A	A	A	A	A	A	A	R	D	D	D	D	D	D	D	D	Fixed program ROM

## RETURN OF THE JEDI Memory Map (Sound CPU)

HEXA-DECIMAL ADDRESS	ADDRESS BUS SIGNAL LINES																READ/ WRITE	DATA BUS SIGNAL LINES								FUNCTION
	A15	A14	A13	A12	A11	A10	A9	A8	A7	A6	A5	A4	A3	A2	A1	A0		D7	D6	D5	D4	D3	D2	D1	D0	
0000-07FF	0	0	0	0	A	A	A	A	A	A	A	A	A	A	A	A	R/W	D	D	D	D	D	D	D	D	Z-page working RAM
0800-083F	0	0	0	1							A	A	A	A	A	A	R/W	D	D	D	D	D	D	D	D	Custom I/O
1000	0	0	1	0	0	0	0										W									Interrupt acknowledge
1100	0	0	1	0	0	0	1										W	D	D	D	D	D	D	D	D	Speech data
1200	0	0	1	0	0	1	0										W									Speech write strobe on
1300	0	0	1	0	0	1	1										W									Speech write strobe off
1400	0	0	1	0	1	0	0										W	D	D	D	D	D	D	D	D	Main CPU acknowledge latch
1500	0	0	1	0	1	0	1										W							D		Speech chip reset
1800	0	0	1	1	0												R	D	D	D	D	D	D	D	D	Main CPU communication latch
1C00	0	0	1	1	1												0	R	D							Speech chip ready
1C01	0	0	1	1	1												1	R	D							Sound CPU communication latch full flag
1C01	0	0	1	1	1												1	R		D						Sound CPU acknowledge latch full flag
8000-FFFF	1	A	A	A	A	A	A	A	A	A	A	A	A	A	A	A	R	D	D	D	D	D	D	D	D	Program ROM

**NOTICE TO ALL PERSONS RECEIVING THIS DRAWING**  
CONFIDENTIAL. Reproduction forbidden without the specific written permission of Atari, Inc., Sunnyvale, CA. This drawing is only conditionally issued, and neither receipt nor possession thereof confers or transfers any right in, or license to use, the subject matter of the drawing or any design or technical information shown thereon, nor any right to reproduce this drawing or any part thereof. Except for manufacture by vendors of Atari, Inc., and for manufacture under the corporation's written license, no right is granted to reproduce this drawing or the subject matter thereof, unless by written agreement with or written permission from the corporation.

### JEDI Memory Maps

A Warner Communications Company

© ATARI INC. 1984

**SP-227 Sheet 3B**  
1st printing

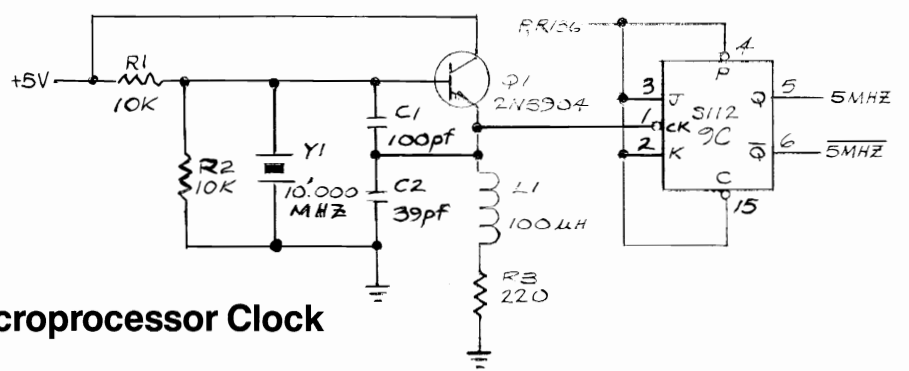
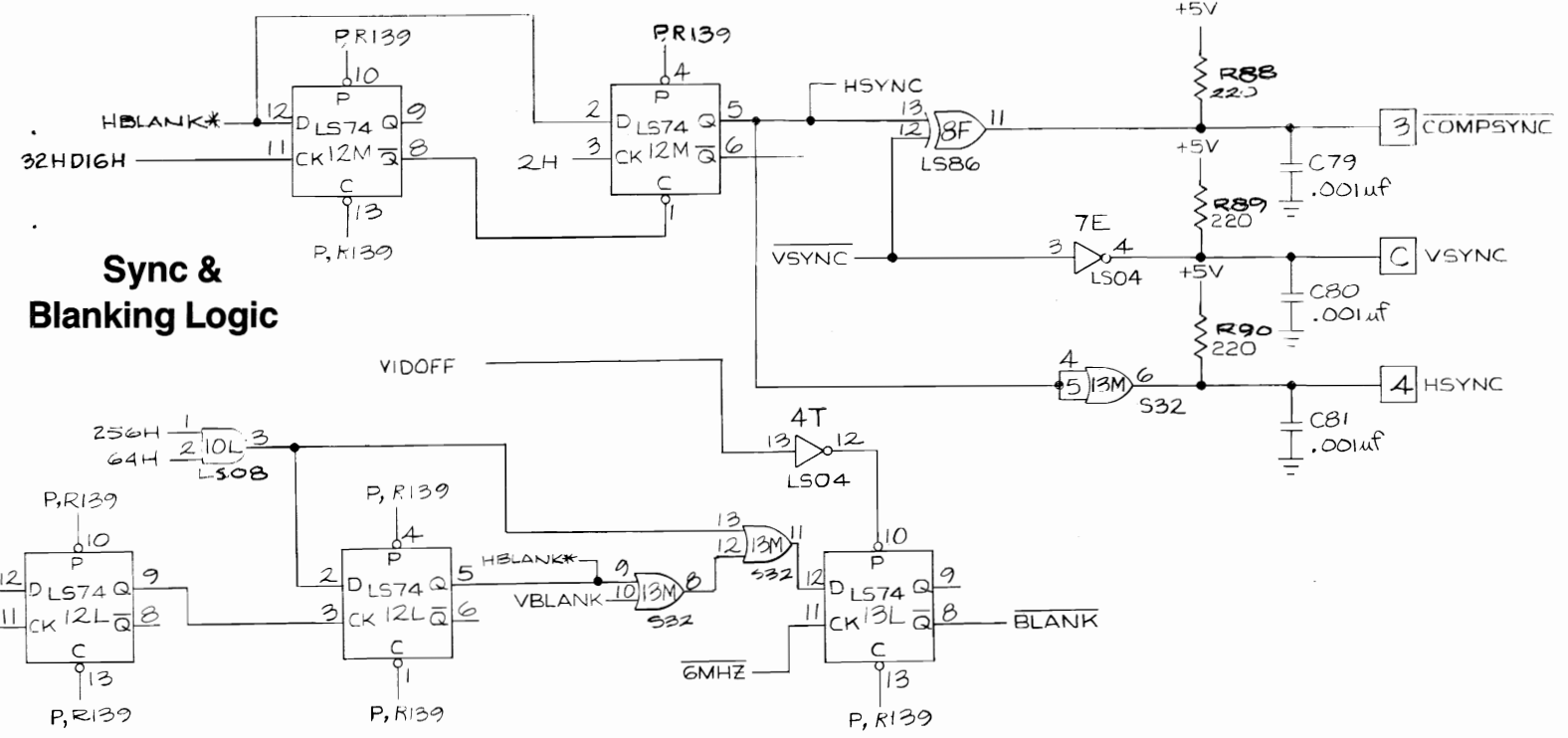
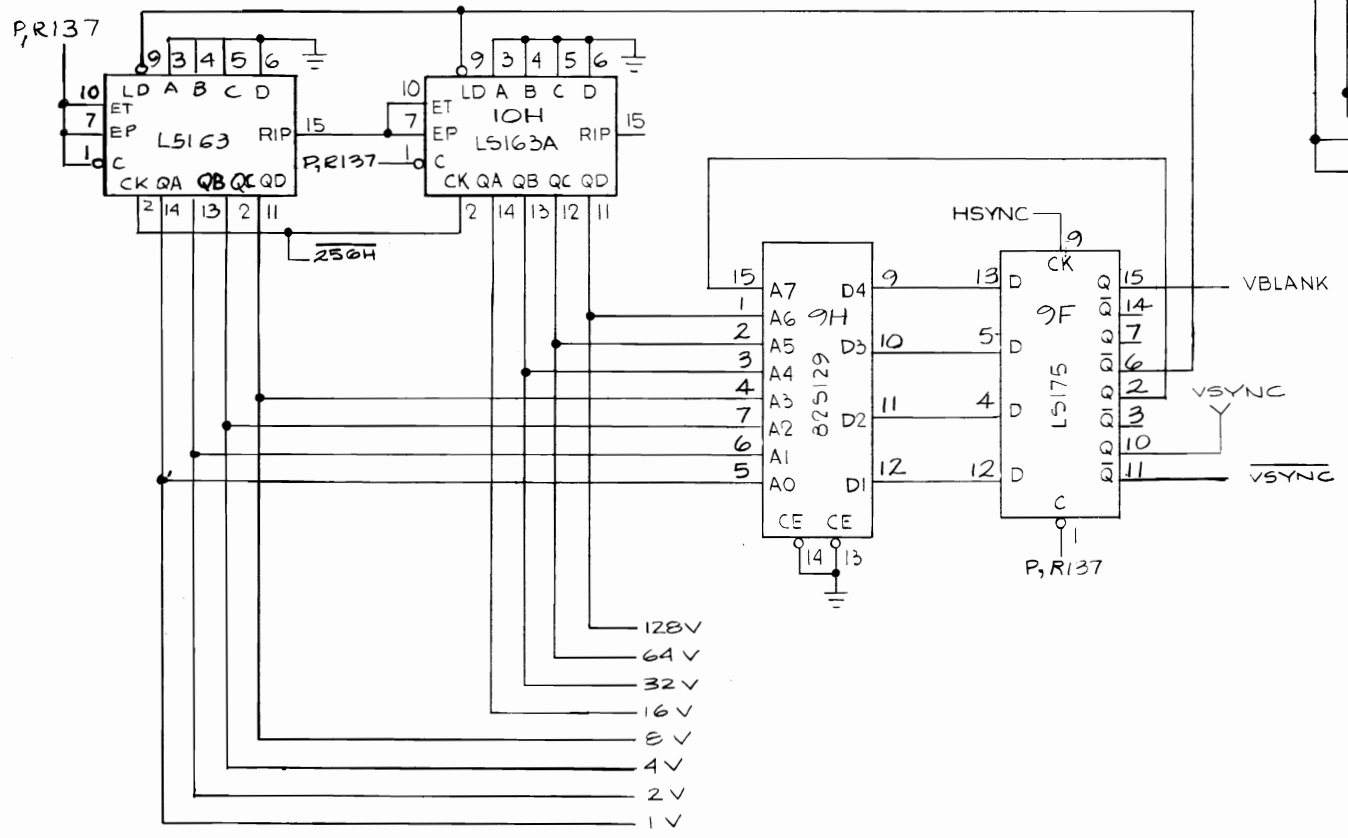
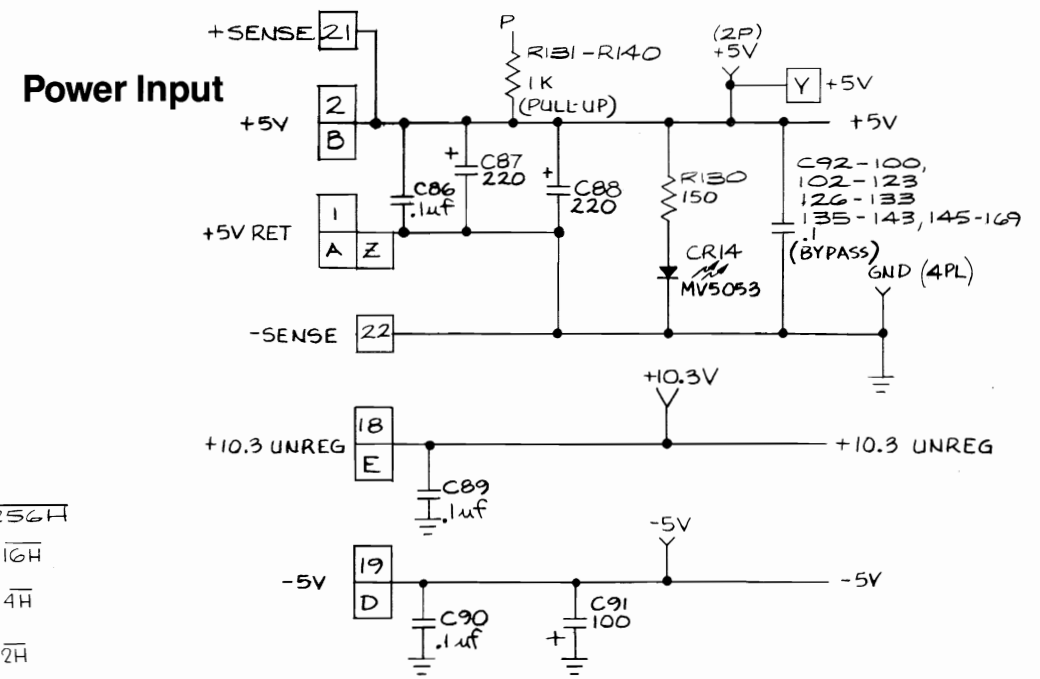
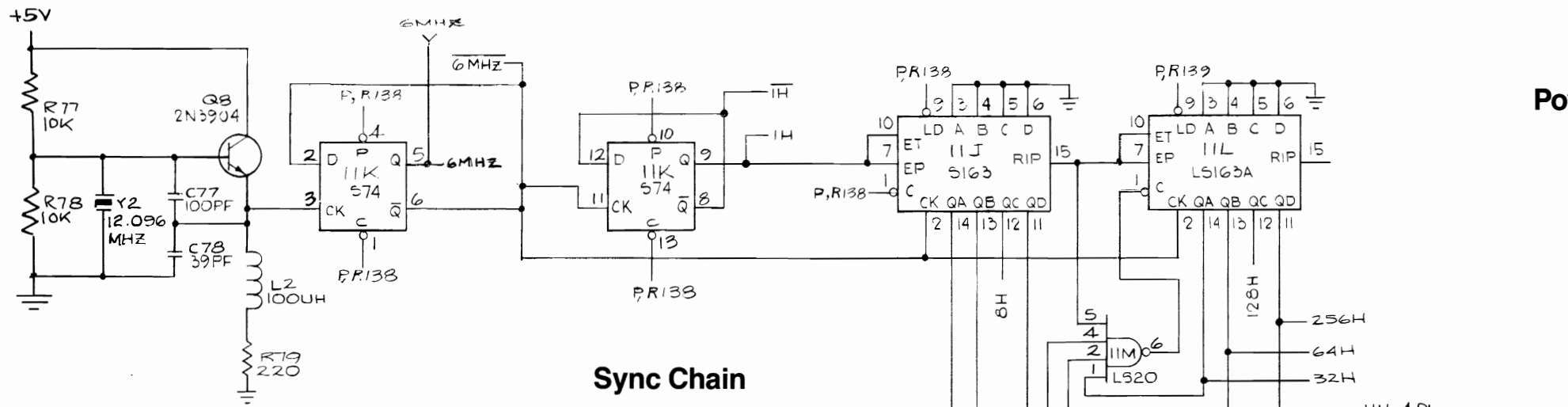

**Main Microprocessor Clock**

**NOTICE TO ALL PERSONS RECEIVING THIS DRAWING**  
 CONFIDENTIAL: Reproduction forbidden without the specific written permission of Atari, Inc., Sunnyvale, CA. This drawing is only conditionally issued, and neither receipt nor possession thereof confers or transfers any right in, or license to use, the subject matter of the drawing or any design or technical information shown thereon, nor any right to reproduce this drawing or any part thereof. Except for manufacture by vendors of Atari, Inc., and for manufacture under the corporation's written license, no right is granted to reproduce this drawing or the subject matter thereof, unless by written agreement with or written permission from the corporation.

**JEDI Game PCB Schematic**

**ATARI**  
 A Warner Communications Company

SP-227 Sheet 4A  
 1st printing

© ATARI INC. 1984

# Main Microprocessor

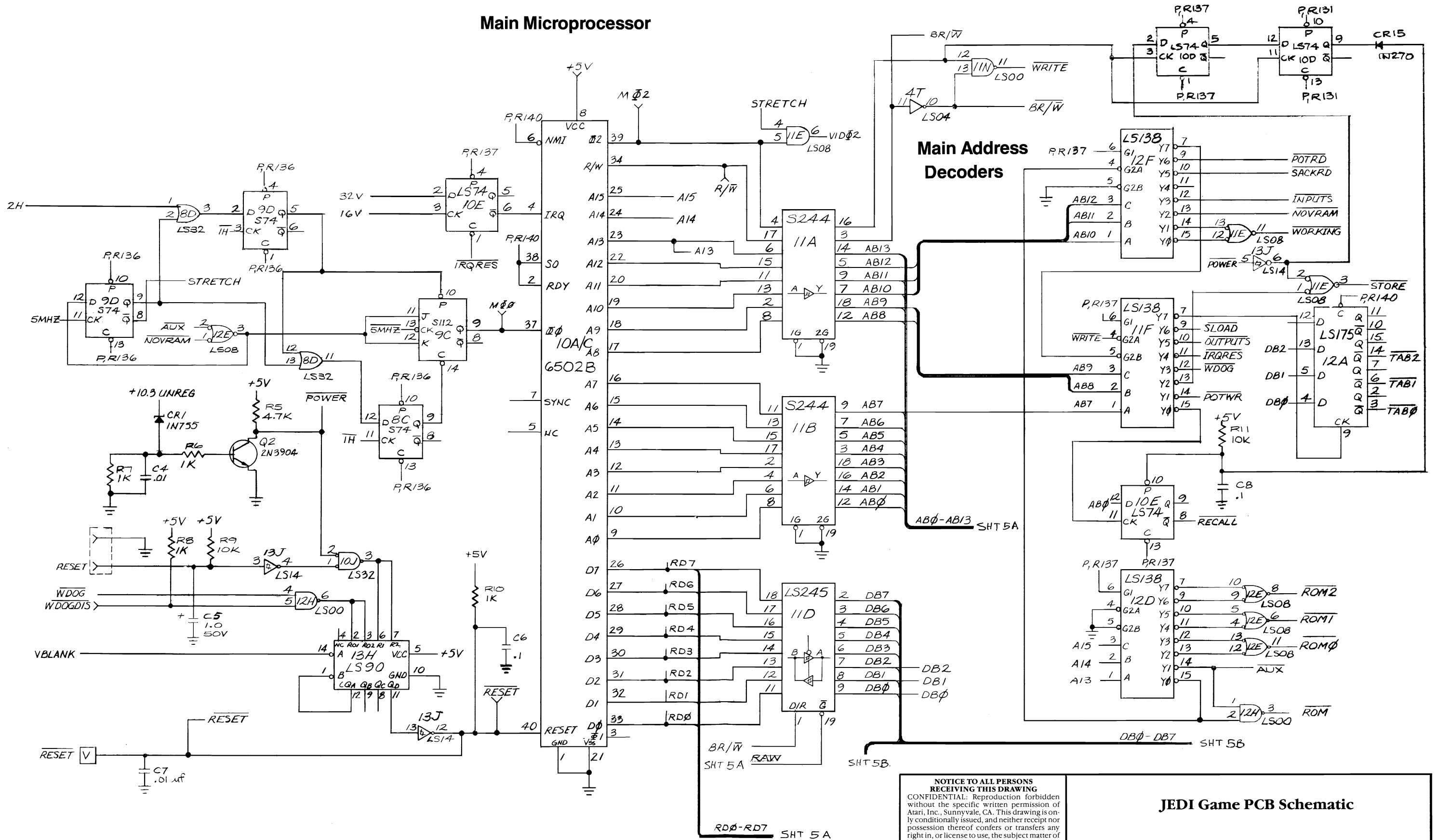

**NOTICE TO ALL PERSONS RECEIVING THIS DRAWING**  
 CONFIDENTIAL. Reproduction forbidden without the specific written permission of Atari, Inc., Sunnyvale, CA. This drawing is only conditionally issued, and neither receipt nor possession thereof confers or transfers any right in, or license to use, the subject matter of the drawing or any design or technical information shown thereon, nor any right to reproduce this drawing or any part thereof. Except for manufacture by vendors of Atari, Inc., and for manufacture under the corporation's written license, no right is granted to reproduce this drawing or the subject matter thereof, unless by written agreement with or written permission from the corporation.

**JEDI Game PCB Schematic**

  
 A Warner Communications Company

© ATARI INC. 1984  
 SP-227 Sheet 4B  
 1st printing



**Program RAM**

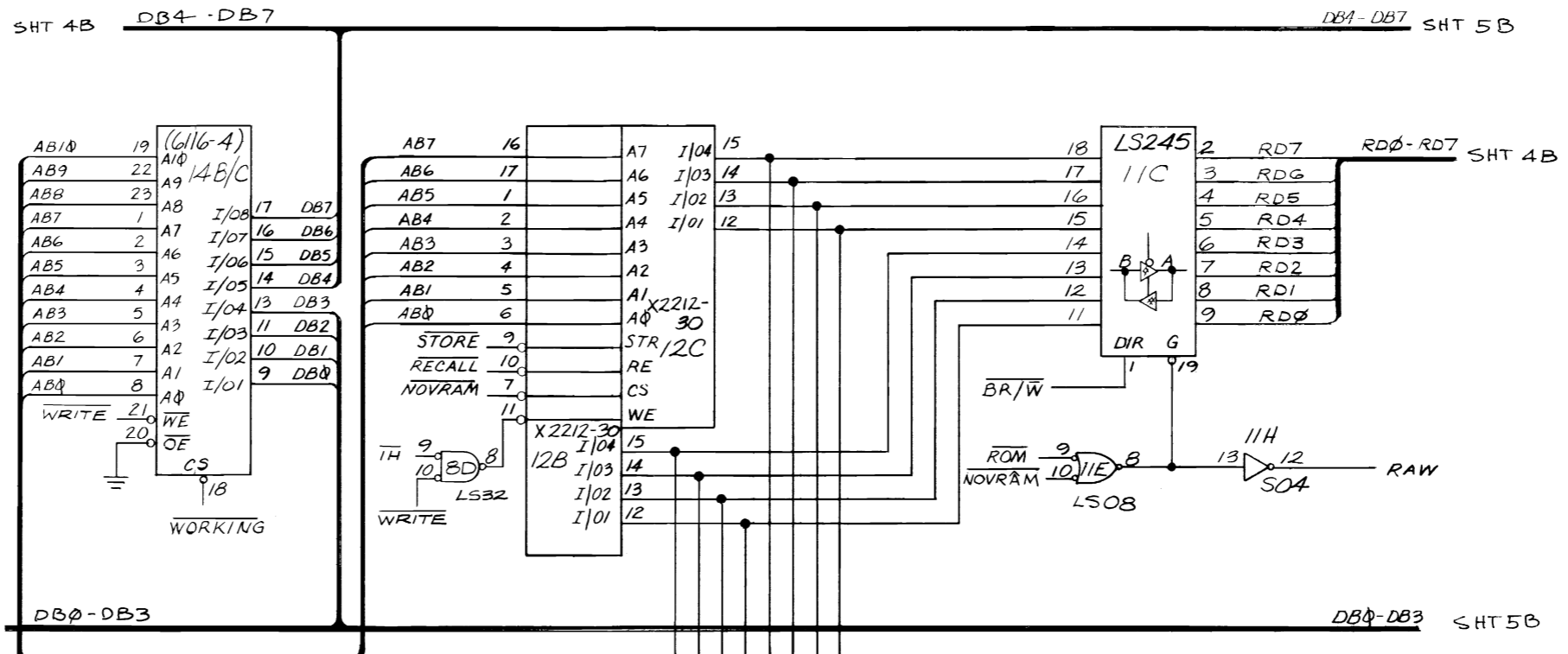

SHT 4B AB0-AB13

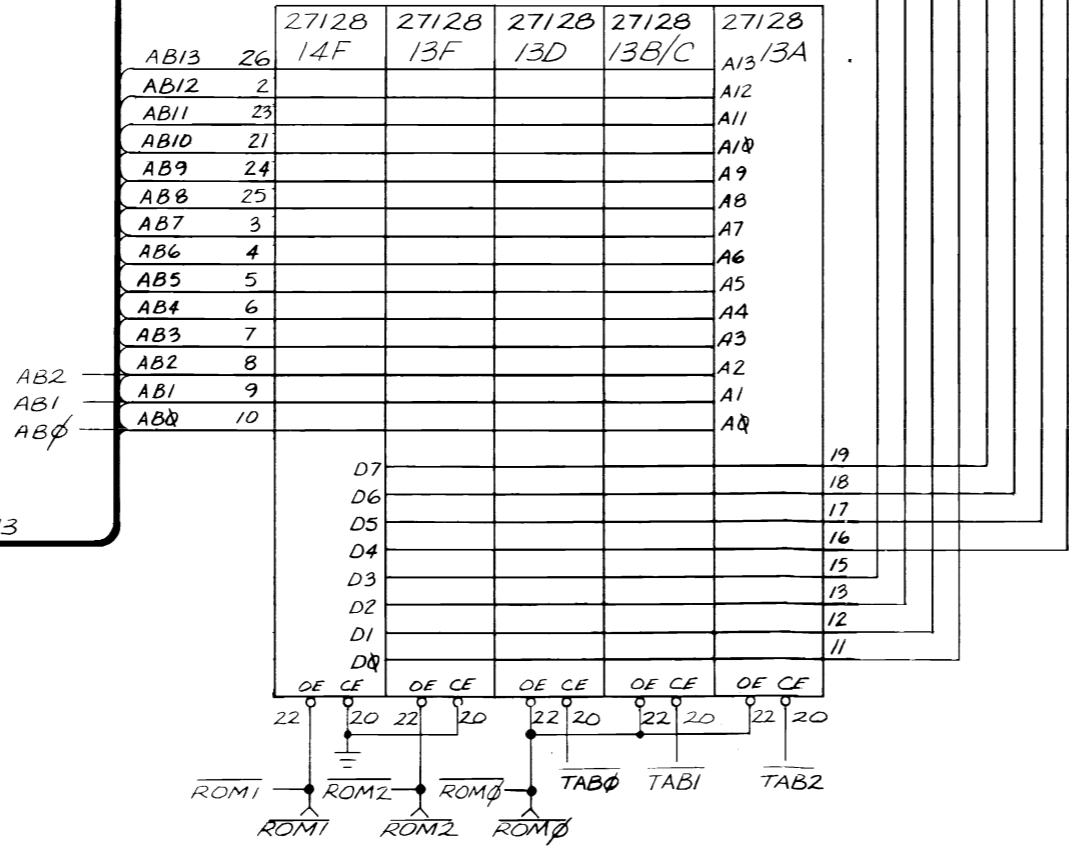

**Program ROM**

**NOTICE TO ALL PERSONS RECEIVING THIS DRAWING**

CONFIDENTIAL: Reproduction forbidden without the specific written permission of Atari, Inc., Sunnyvale, CA. This drawing is only conditionally issued, and neither receipt nor possession thereof confers or transfers any right in, or license to use, the subject matter of the drawing or any design or technical information shown thereon, nor any right to reproduce this drawing or any part thereof. Except for manufacture by vendors of Atari, Inc., and for manufacture under the corporation's written license, no right is granted to reproduce this drawing or the subject matter thereof, unless by written agreement with or written permission from the corporation.

**JEDI Game PCB Schematic**

© ATARI INC. 1984

SP-227 Sheet 5A  
1st printing

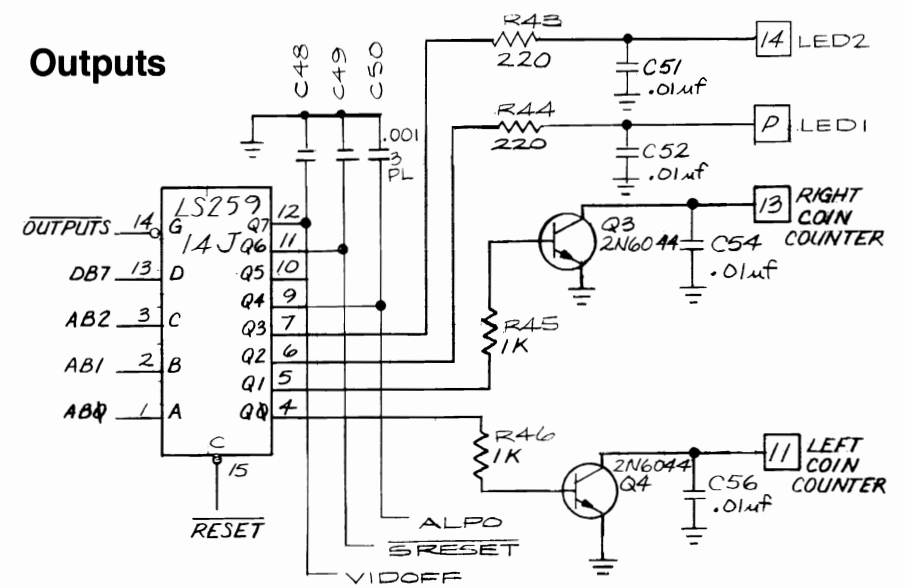
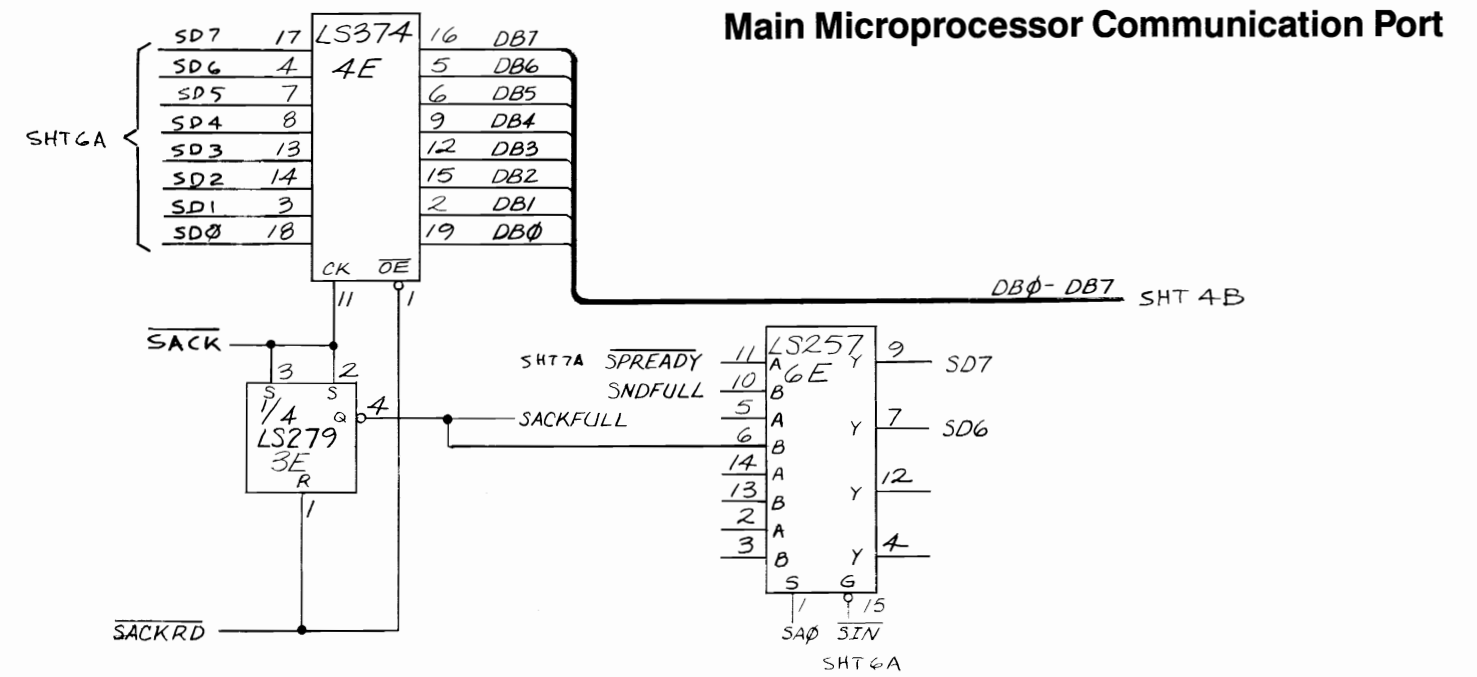
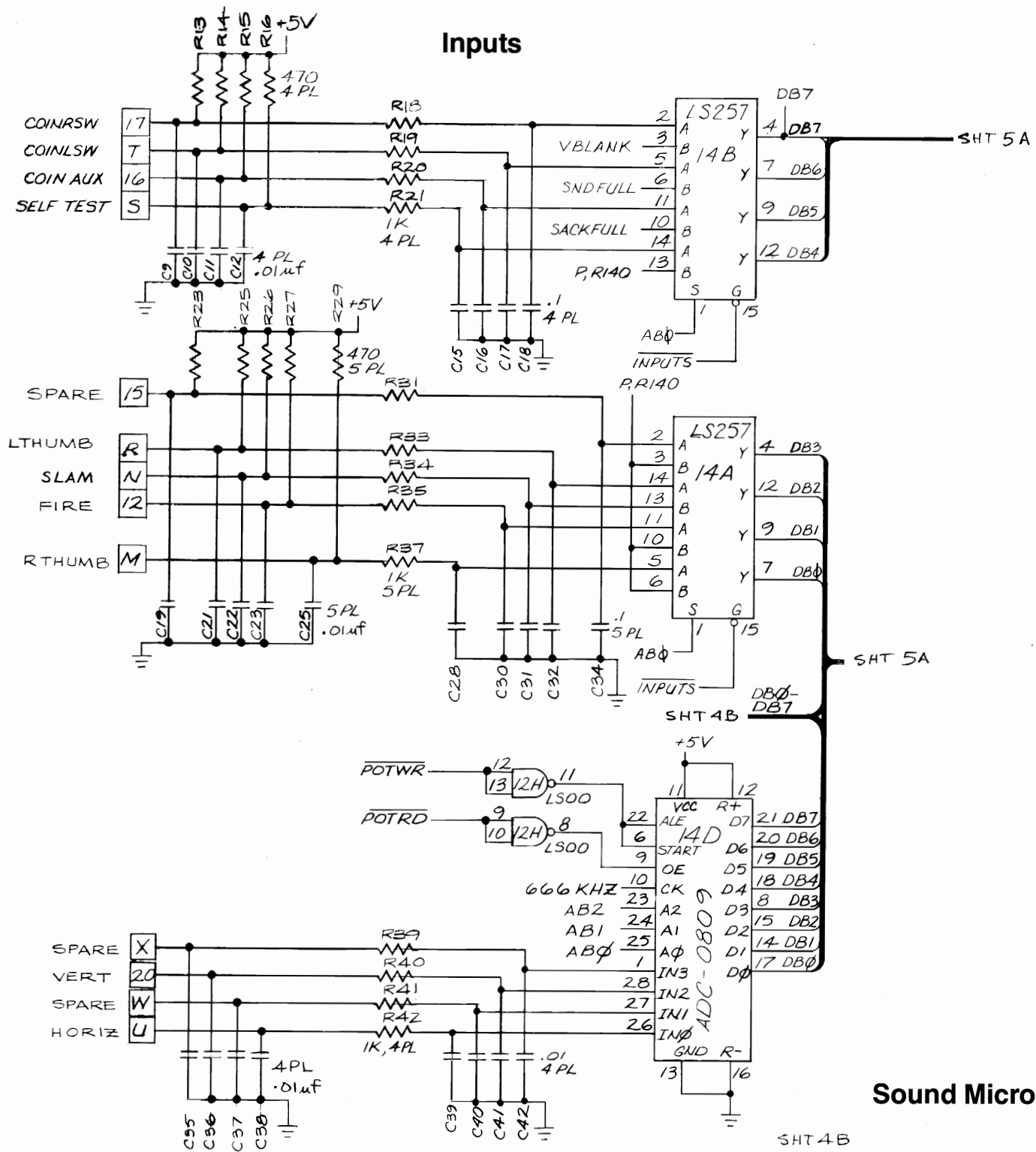

### Sound Microprocessor Communication Port

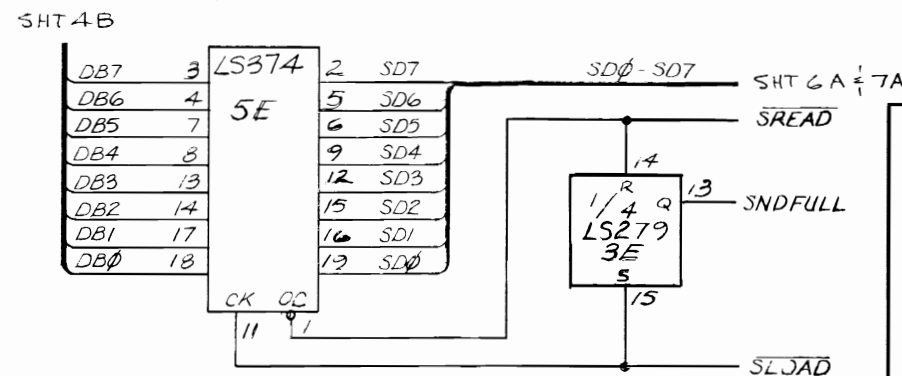

**NOTICE TO ALL PERSONS RECEIVING THIS DRAWING**  
 CONFIDENTIAL: Reproduction forbidden without the specific written permission of Atari, Inc., Sunnyvale, CA. This drawing is only conditionally issued, and neither receipt nor possession thereof confers or transfers any right in, or license to use, the subject matter of the drawing or any design or technical information shown thereon, nor any right to reproduce this drawing or any part thereof. Except for manufacture by vendors of Atari, Inc., and for manufacture under the corporation's written license, no right is granted to reproduce this drawing or the subject matter thereof, unless by written agreement with or written permission from the corporation.

## JEDI Game PCB Schematic

© ATARI INC. 1984

SP-227 Sheet 5B  
1st printing

### Sound Microprocessor

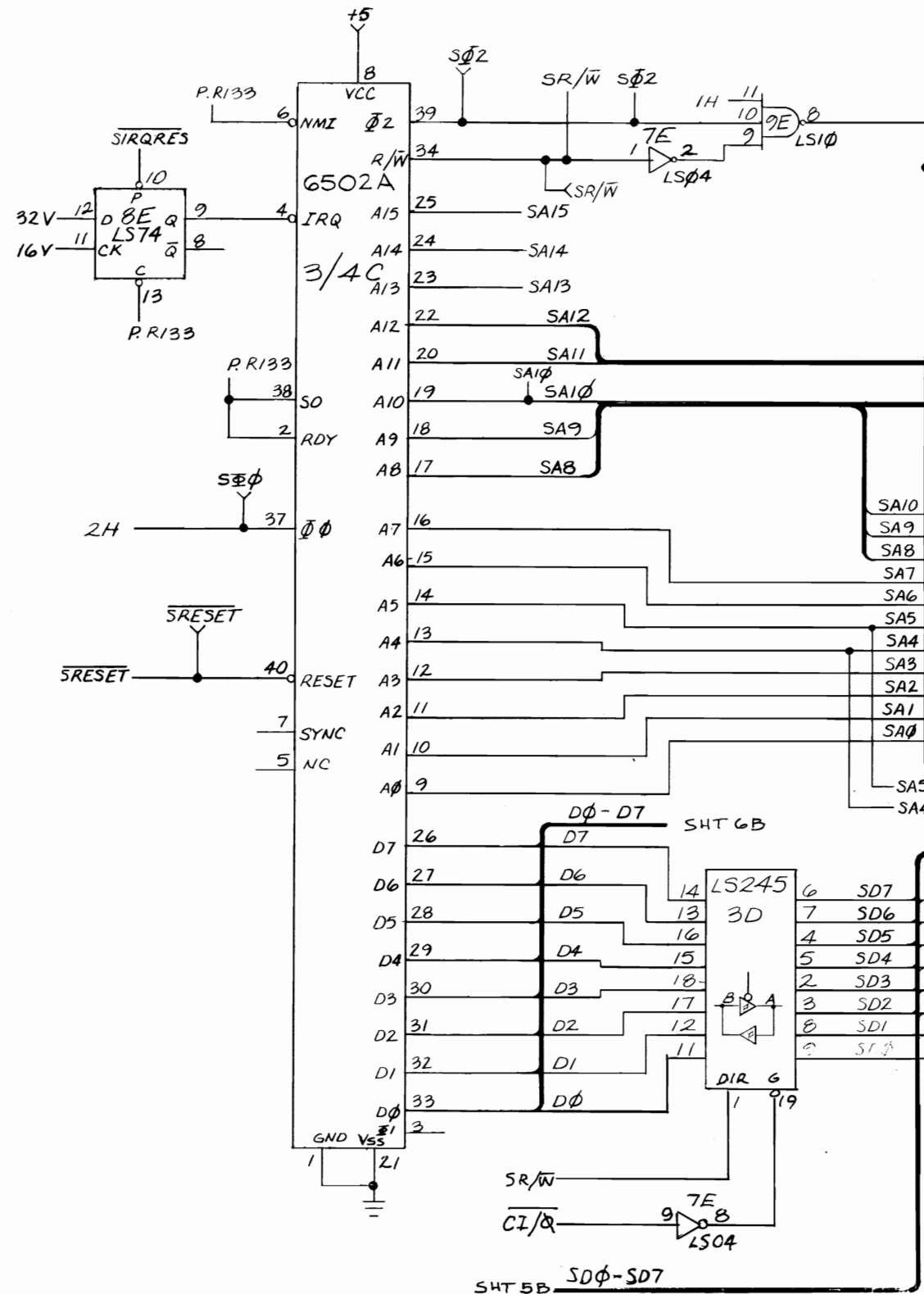

### Sound Address Decoders

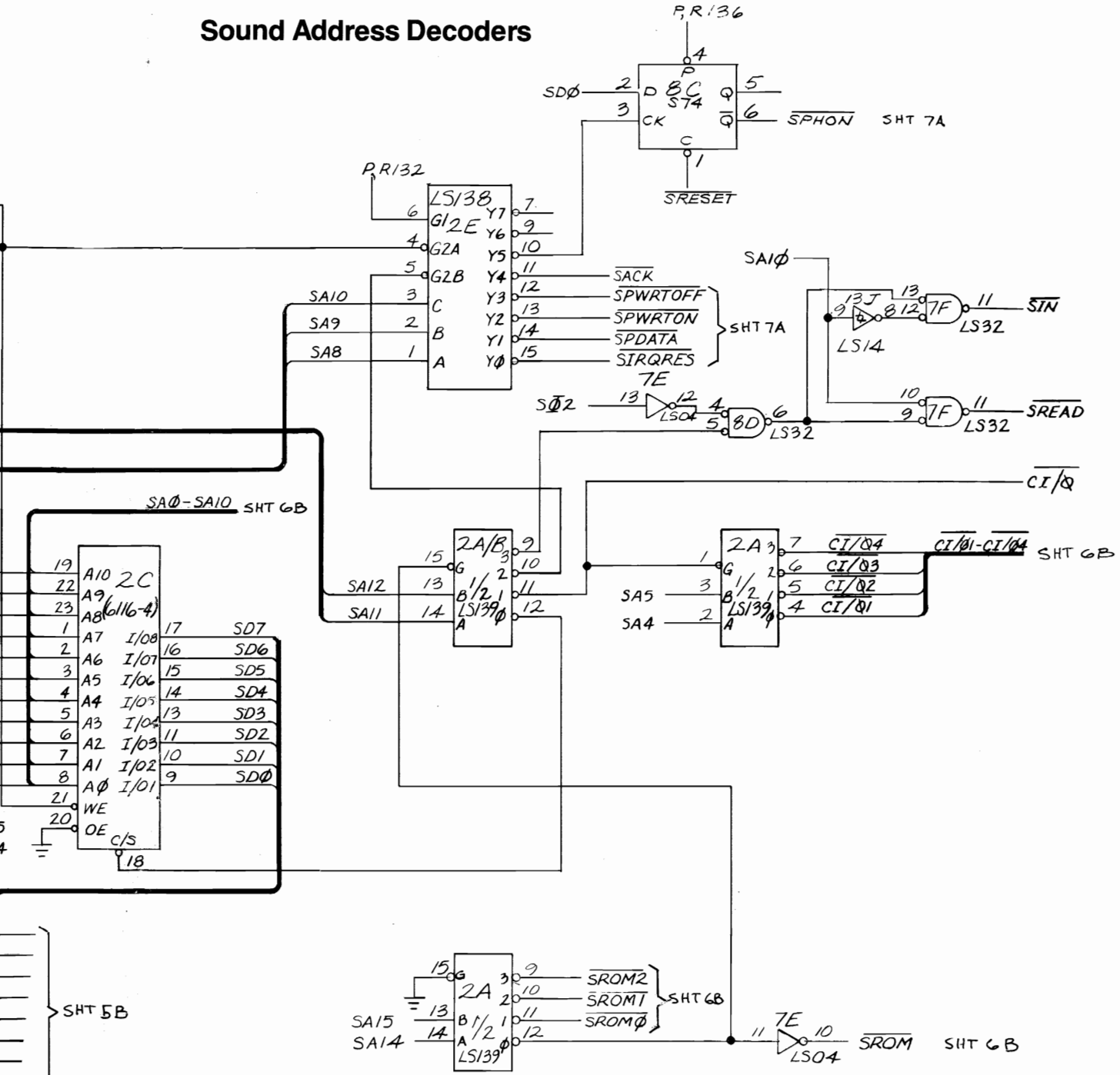

**NOTICE TO ALL PERSONS RECEIVING THIS DRAWING**  
 CONFIDENTIAL: Reproduction forbidden without the specific written permission of Atari, Inc., Sunnyvale, CA. This drawing is only conditionally issued, and neither receipt nor possession thereof confers or transfers any right in, or license to use, the subject matter of the drawing or any design or technical information shown thereon, nor any right to reproduce this drawing or any part thereof. Except for manufacture by vendors of Atari, Inc., and for manufacture under the corporation's written license, no right is granted to reproduce this drawing or the subject matter thereof, unless by written agreement with or written permission from the corporation.

**JEDI Game PCB Schematic**

  
 © ATARI INC. 1984

SP-227 Sheet 6A  
1st printing

# Music & Sound Effects

# Sound Mixing

## Sound Program ROM

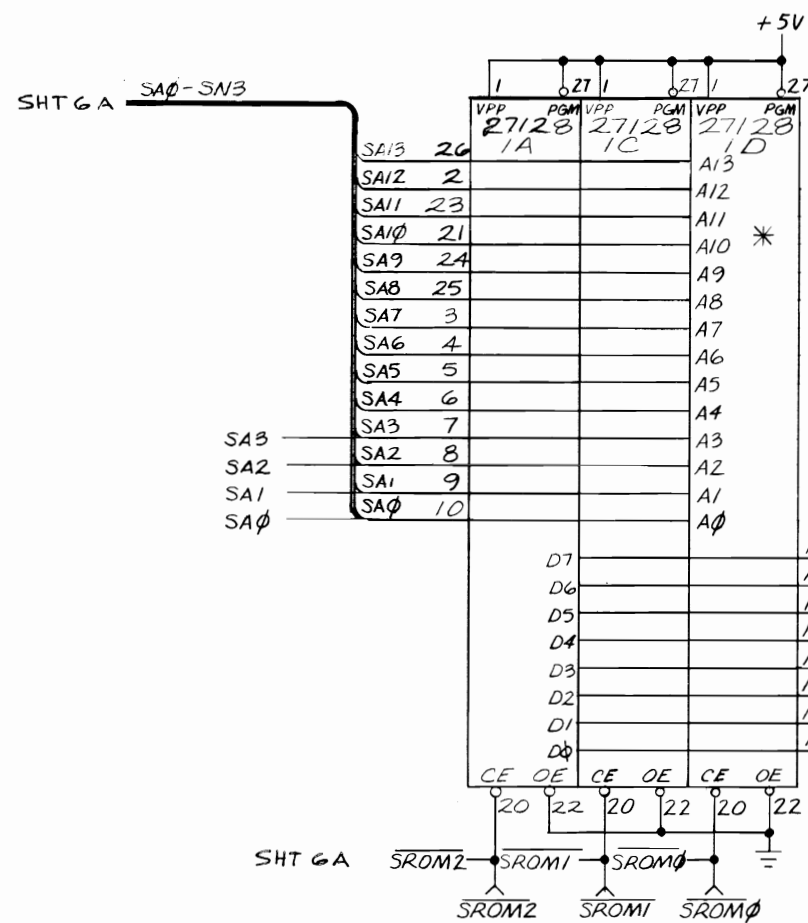

\* COMPONENT ID NOT LOADED.

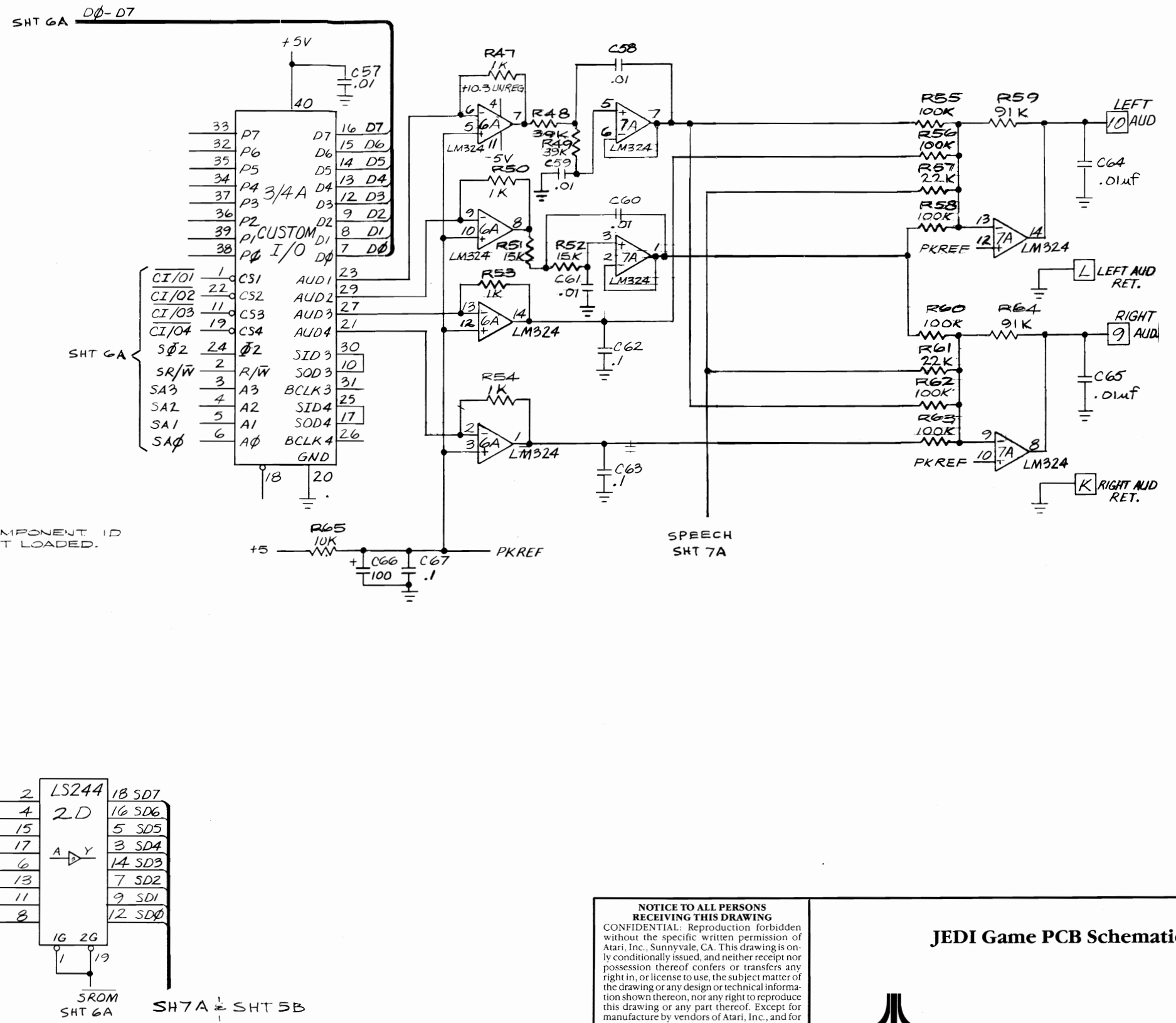

**NOTICE TO ALL PERSONS RECEIVING THIS DRAWING**  
 CONFIDENTIAL: Reproduction forbidden without the specific written permission of Atari, Inc., Sunnyvale, CA. This drawing is only conditionally issued, and neither receipt nor possession thereof confers or transfers any right in, or license to use, the subject matter of the drawing or any design or technical information shown thereon, nor any right to reproduce this drawing or any part thereof. Except for manufacture by vendors of Atari, Inc., and for manufacture under the corporation's written license, no right is granted to reproduce this drawing or the subject matter thereof, unless by written agreement with or written permission from the corporation.

**JEDI Game PCB Schematic**



© ATARI INC. 1984

SP-227 Sheet 6B  
1st printing

# Speech

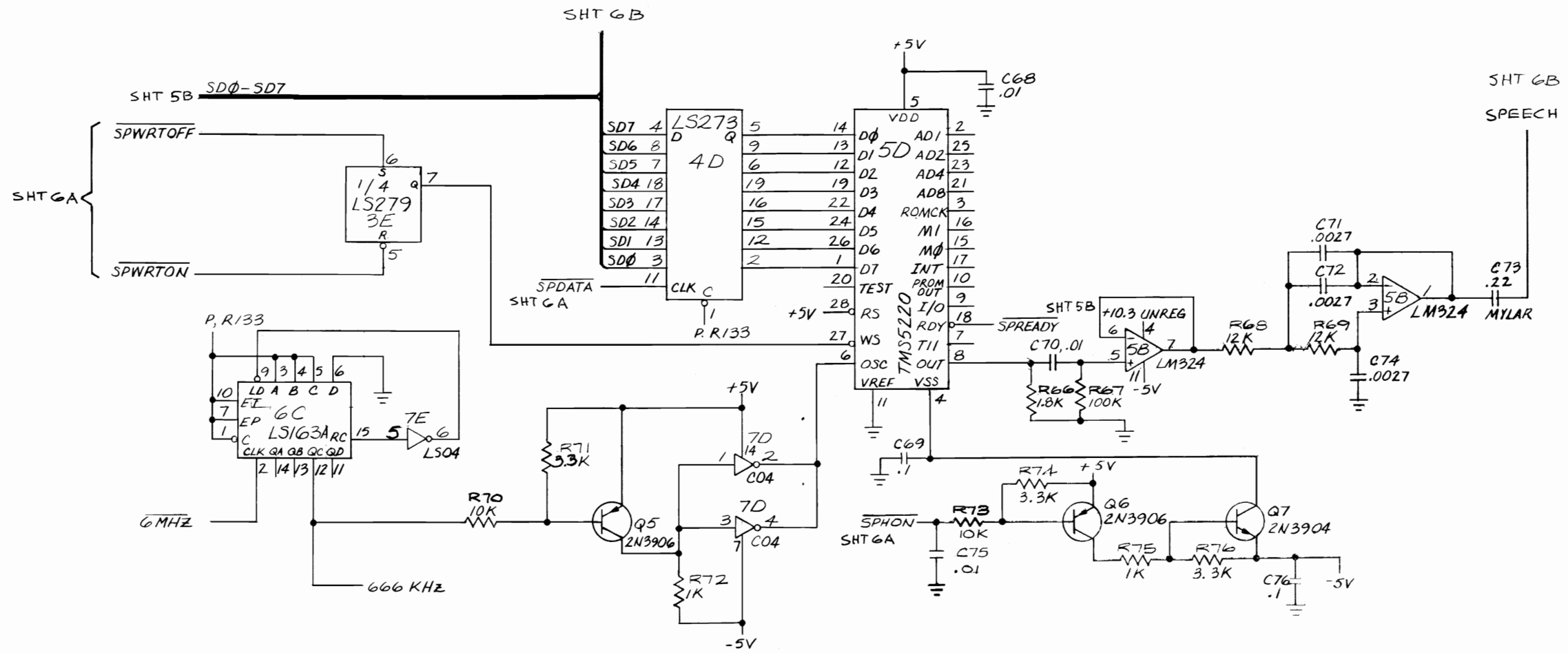

**NOTICE TO ALL PERSONS RECEIVING THIS DRAWING**  
 CONFIDENTIAL: Reproduction forbidden without the specific written permission of Atari, Inc., Sunnyvale, CA. This drawing is only conditionally issued, and neither receipt nor possession thereof confers or transfers any right in, or license to use, the subject matter of the drawing or any design or technical information shown thereon, nor any right to reproduce this drawing or any part thereof. Except for manufacture by vendors of Atari, Inc., and for manufacture under the corporation's written license, no right is granted to reproduce this drawing or the subject matter thereof, unless by written agreement with or written permission from the corporation.

## JEDI Game PCB Schematic



A Warner Communications Company

© ATARI INC. 1984

SP-227 Sheet 7A  
 1st printing

### Video Address Decoders

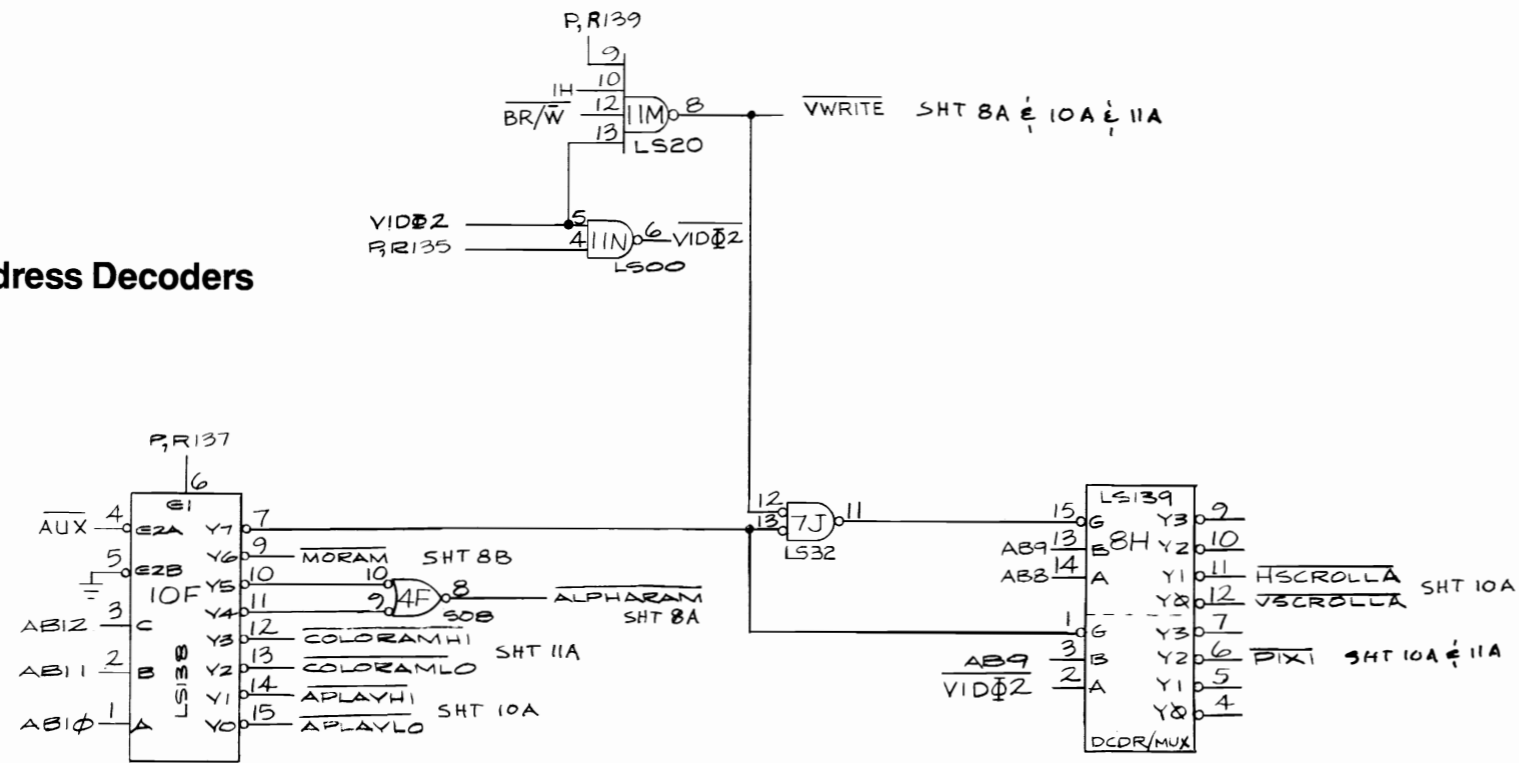

### Motion Object Control

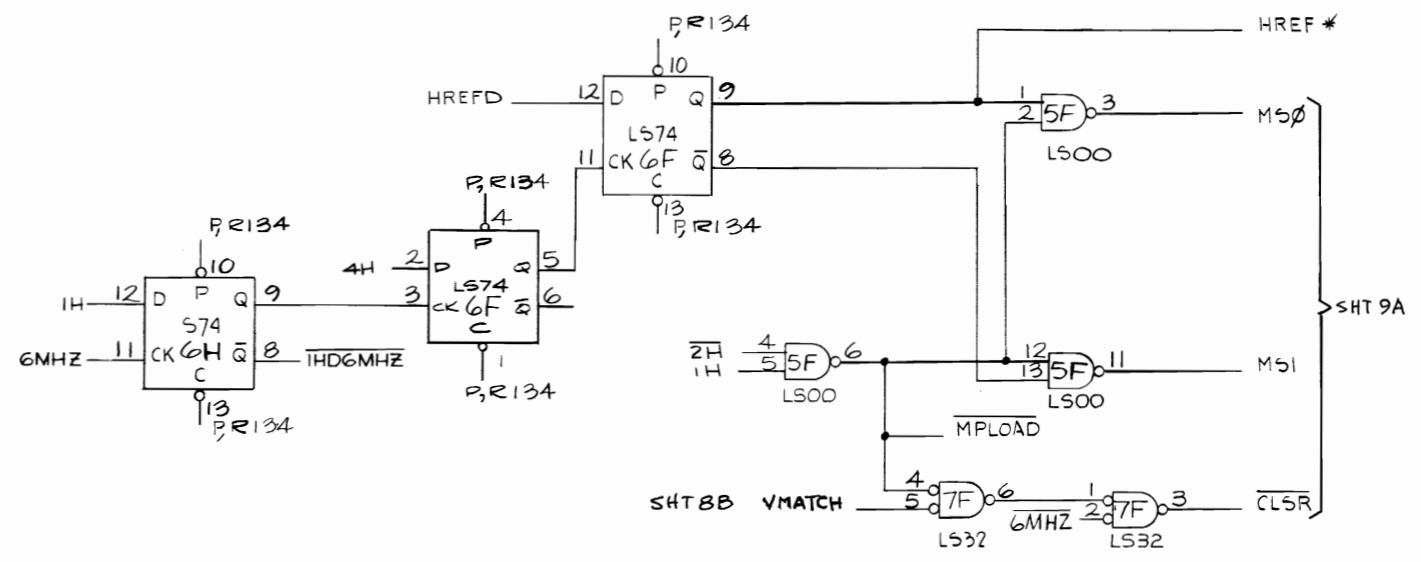

**NOTICE TO ALL PERSONS RECEIVING THIS DRAWING**  
 CONFIDENTIAL: Reproduction forbidden without the specific written permission of Atari, Inc., Sunnyvale, CA. This drawing is only conditionally issued, and neither receipt nor possession thereof confers or transfers any right in, or license to use, the subject matter of the drawing or any design or technical information shown thereon, nor any right to reproduce this drawing or any part thereof. Except for manufacture by vendors of Atari, Inc., and for manufacture under the corporation's written license, no right is granted to reproduce this drawing or the subject matter thereof, unless by written agreement with or written permission from the corporation.

**JEDI Game PCB Schematic**



SP-227 Sheet 7B  
1st printing

© ATARI INC. 1984  
A Warner Communications Company

# Alphanumeric

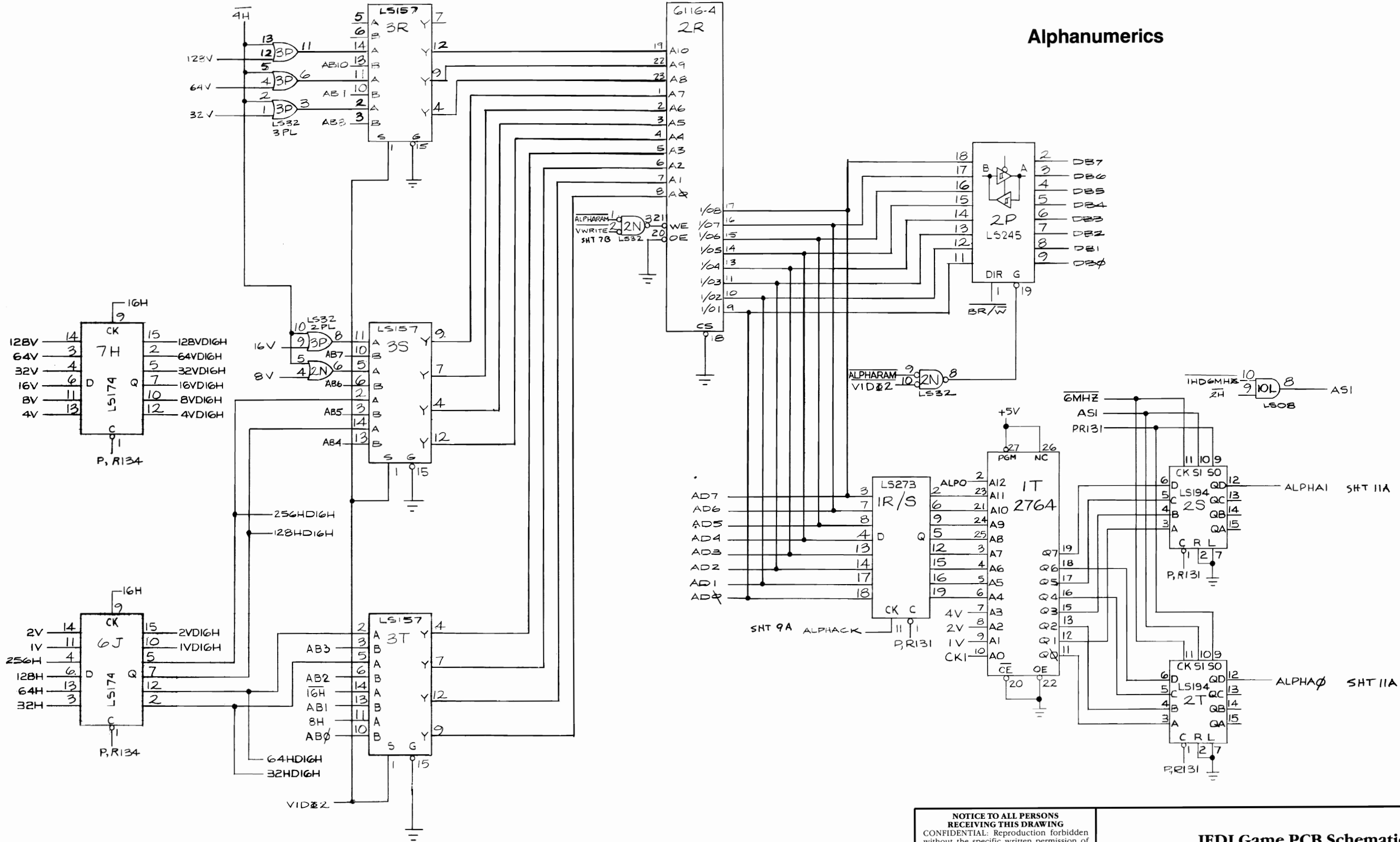

**NOTICE TO ALL PERSONS RECEIVING THIS DRAWING**  
 CONFIDENTIAL: Reproduction forbidden without the specific written permission of Atari, Inc., Sunnyvale, CA. This drawing is only conditionally issued, and neither receipt nor possession thereof confers or transfers any right in, or license to use, the subject matter of the drawing or any design or technical information shown thereon, nor any right to reproduce this drawing or any part thereof. Except for manufacture by vendors of Atari, Inc., and for manufacture under the corporation's written license, no right is granted to reproduce this drawing or the subject matter thereof, unless by written agreement with or written permission from the corporation.

**JEDI Game PCB Schematic**

**ATARI**  
 A Warner Communications Company

© ATARI INC. 1984  
 SP-227 Sheet 8A  
 1st printing

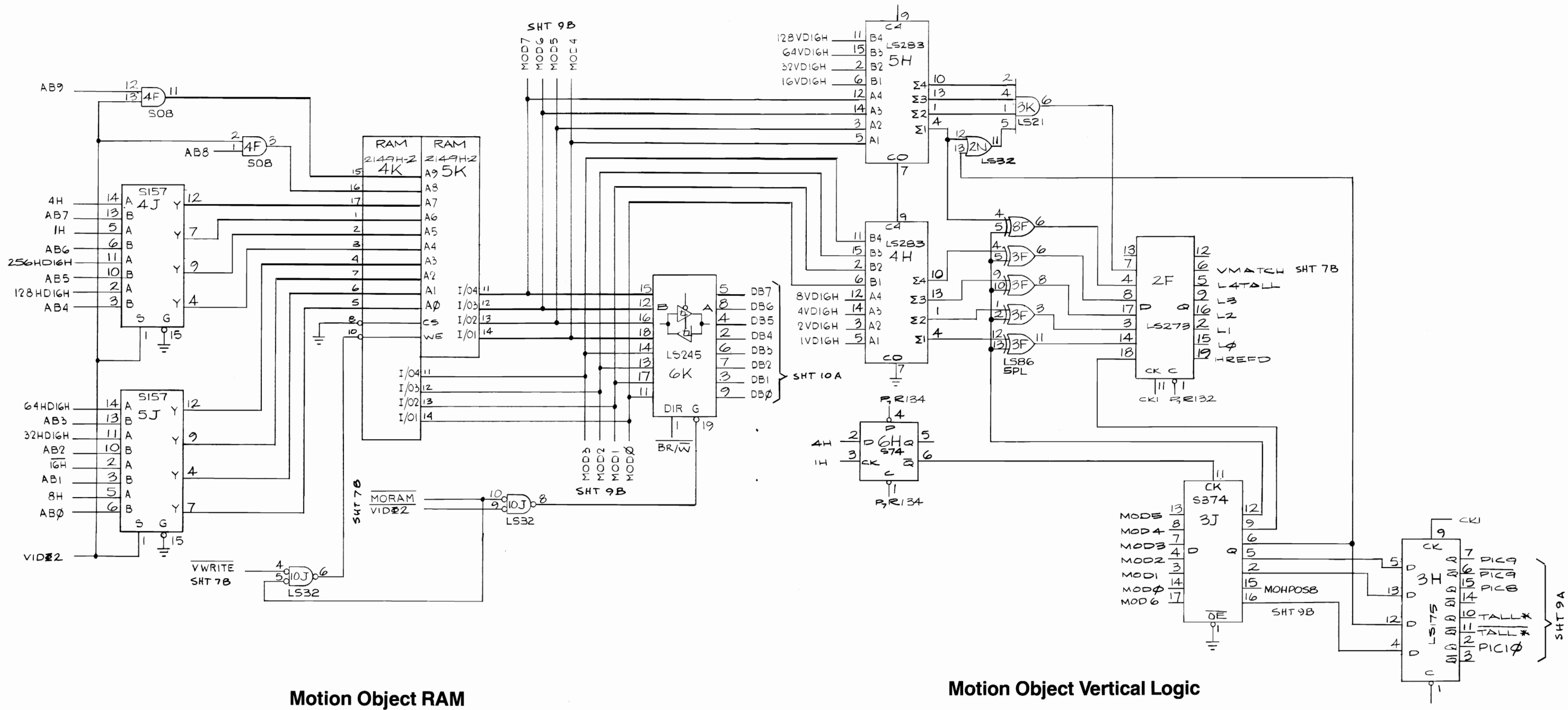

Motion Object RAM

Motion Object Vertical Logic

**NOTICE TO ALL PERSONS RECEIVING THIS DRAWING**  
 CONFIDENTIAL: Reproduction forbidden without the specific written permission of Atari, Inc., Sunnyvale, CA. This drawing is only conditionally issued, and neither receipt nor possession thereof confers or transfers any right in, or license to use, the subject matter of the drawing or any design or technical information shown thereon, nor any right to reproduce this drawing or any part thereof. Except for manufacture by vendors of Atari, Inc., and for manufacture under the corporation's written license, no right is granted to reproduce this drawing or the subject matter thereof, unless by written agreement with or written permission from the corporation.

**JEDI Game PCB Schematic**

  
 A Warner Communications Company

SP-227 Sheet 8B  
1st printing

© ATARI INC. 1984



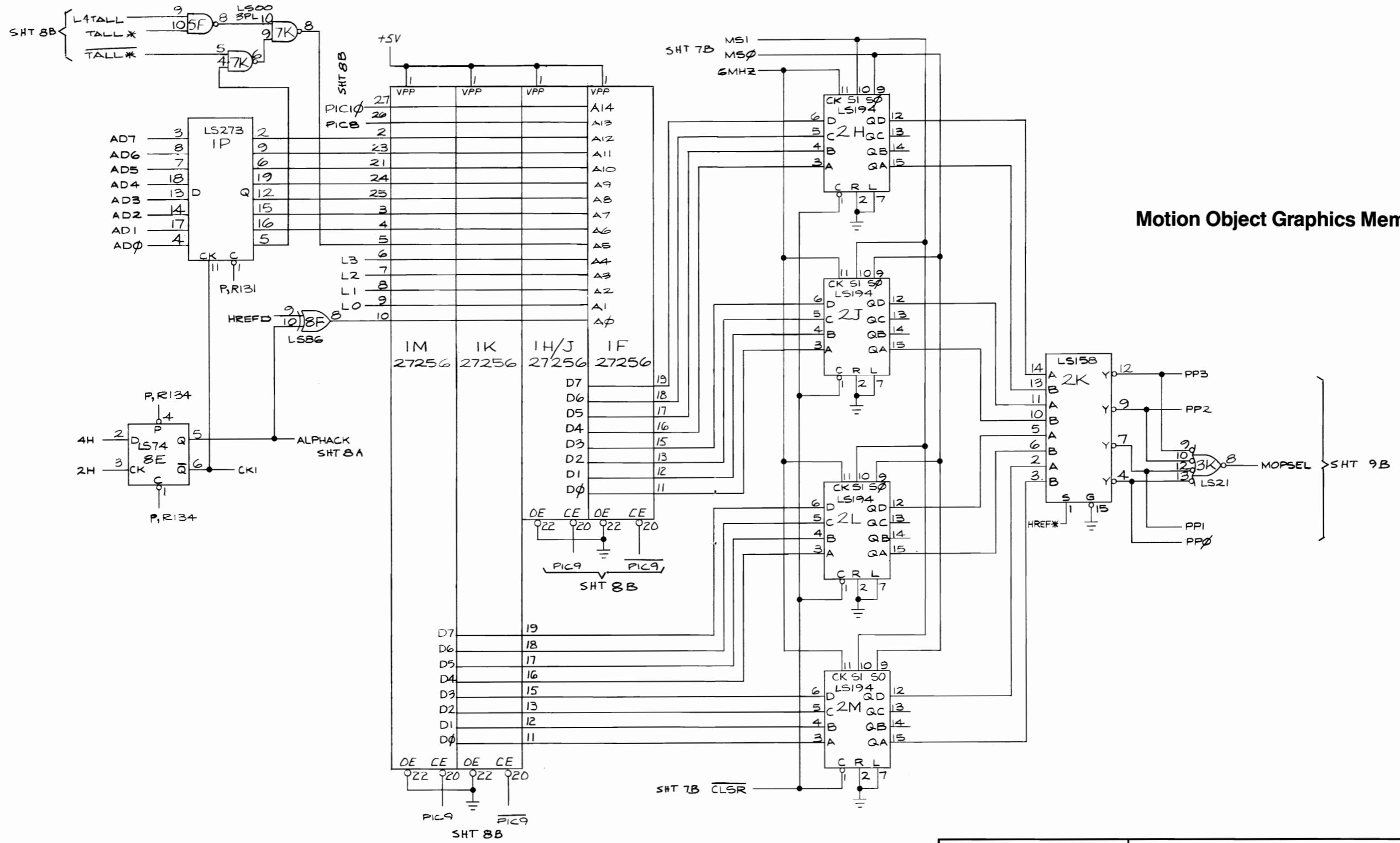

**Motion Object Graphics Memory**

**NOTICE TO ALL PERSONS RECEIVING THIS DRAWING**  
 CONFIDENTIAL: Reproduction forbidden without the specific written permission of Atari, Inc., Sunnyvale, CA. This drawing is only conditionally issued, and neither receipt nor possession thereof confers or transfers any right in, or license to use, the subject matter of the drawing or any design or technical information shown thereon, nor any right to reproduce this drawing or any part thereof. Except for manufacture by vendors of Atari, Inc., and for manufacture under the corporation's written license, no right is granted to reproduce this drawing or the subject matter thereof, unless by written agreement with or written permission from the corporation.

**JEDI Game PCB Schematic**

  
 ATARI

SP-227 Sheet 9A  
1st printing

© ATARI INC. 1984  
 A Warner Communications Company

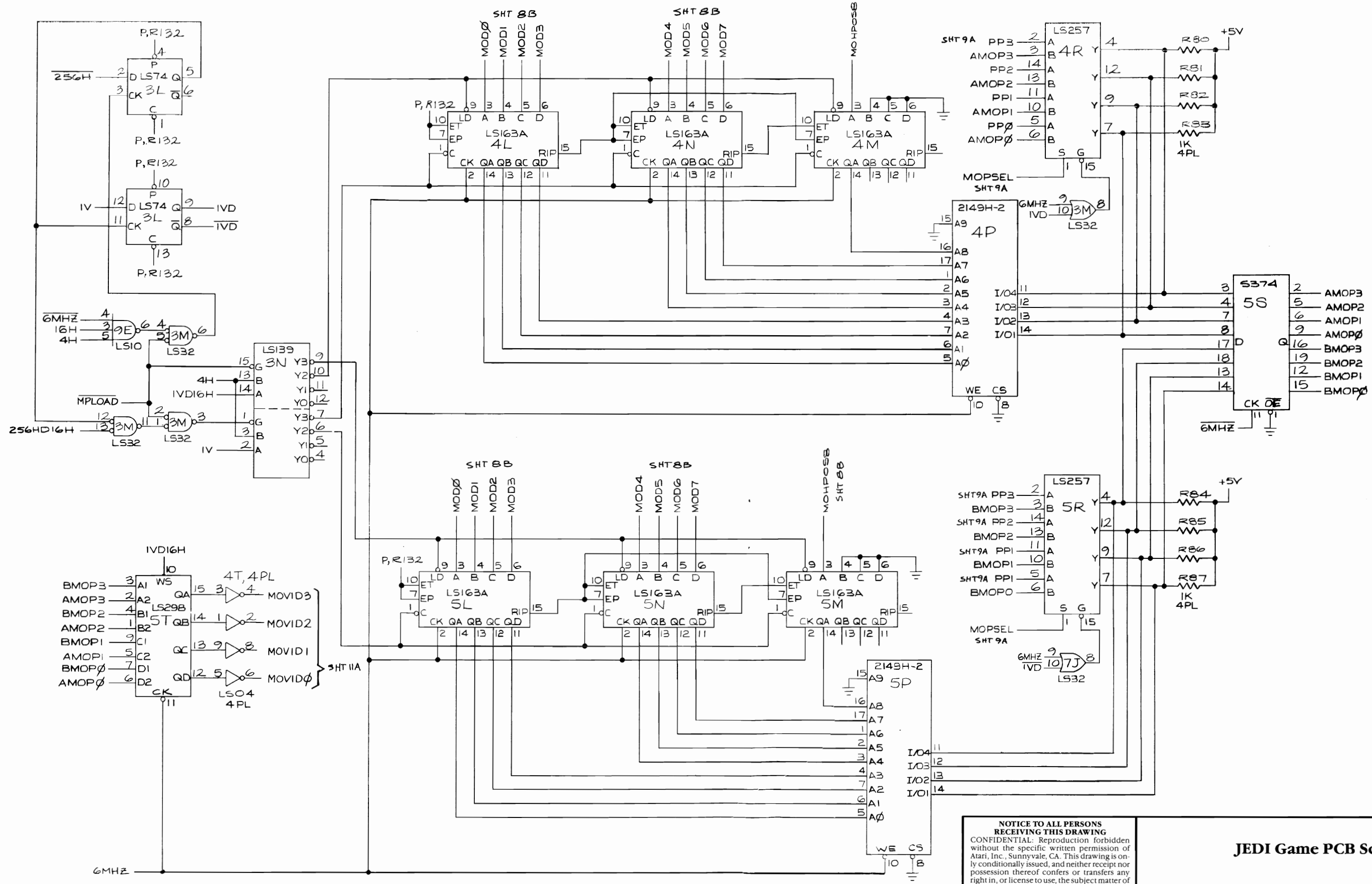

**Motion Object Horizontal Line Buffers**

**NOTICE TO ALL PERSONS RECEIVING THIS DRAWING**  
 CONFIDENTIAL: Reproduction forbidden without the specific written permission of Atari, Inc., Sunnyvale, CA. This drawing is only conditionally issued, and neither receipt nor possession thereof confers or transfers any right in, or license to use, the subject matter of the drawing or any design or technical information shown thereon, nor any right to reproduce this drawing or any part thereof. Except for manufacture by vendors of Atari, Inc., and for manufacture under the corporation's written license, no right is granted to reproduce this drawing or the subject matter thereof, unless by written agreement with or written permission from the corporation.

**JEDI Game PCB Schematic**



A Warner Communications Company

© ATARI INC. 1984

SP-227 Sheet 9B  
 1st printing

### Scrolling Playfield RAM

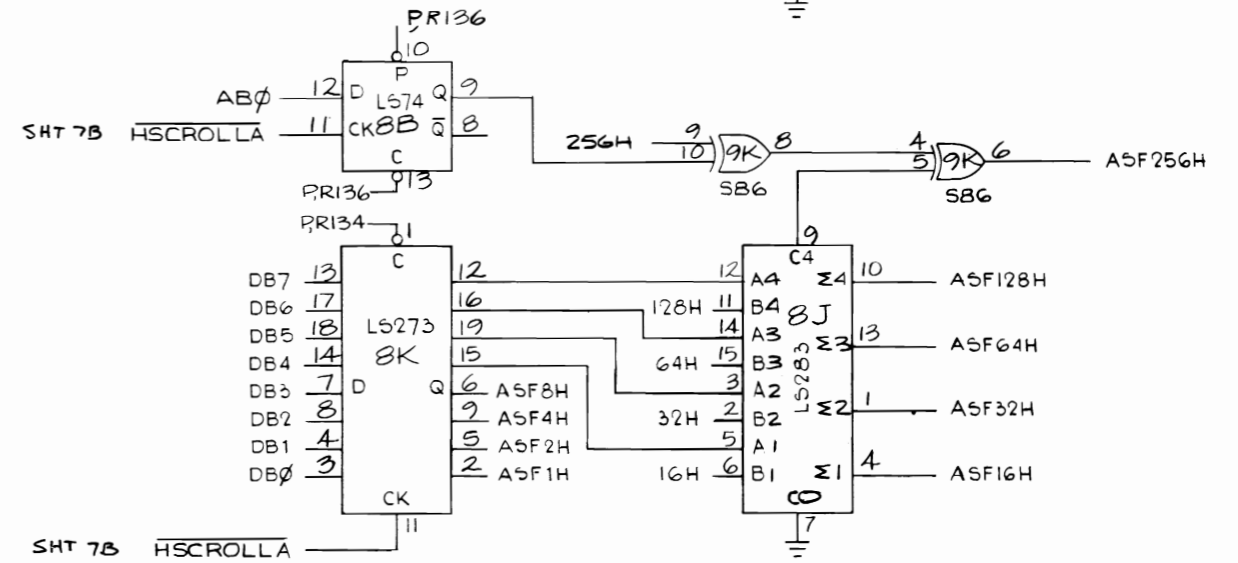
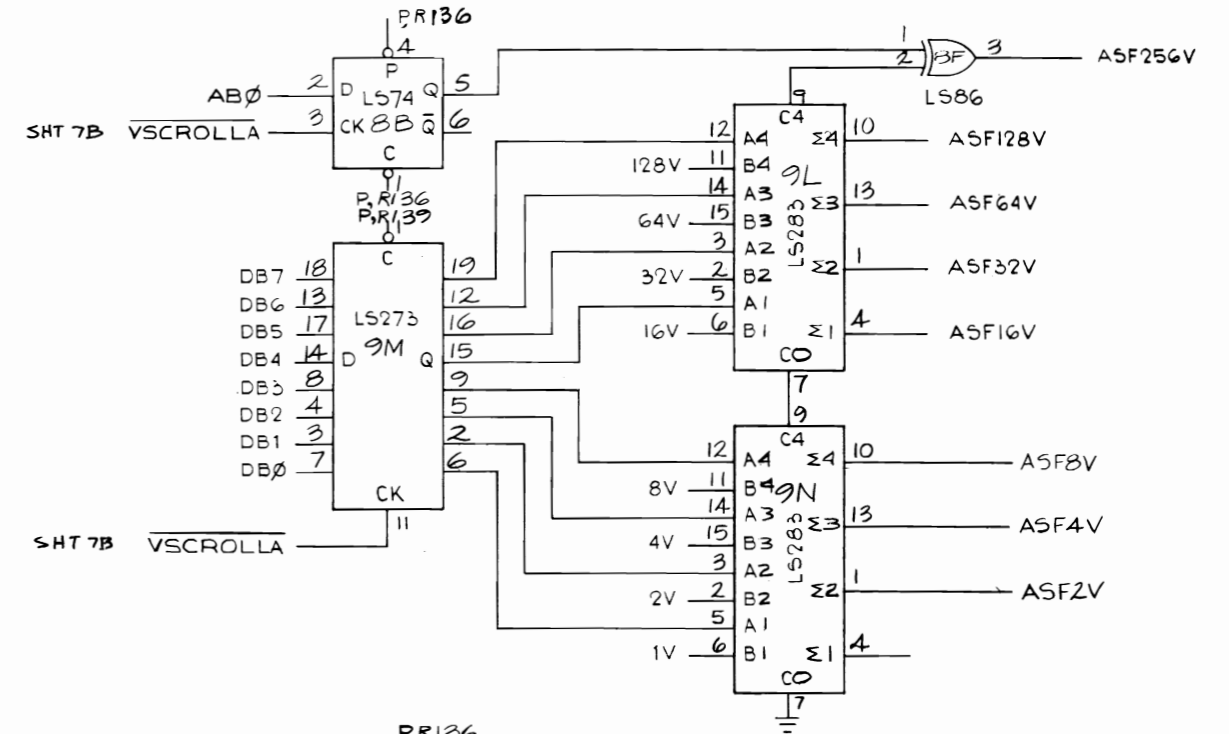
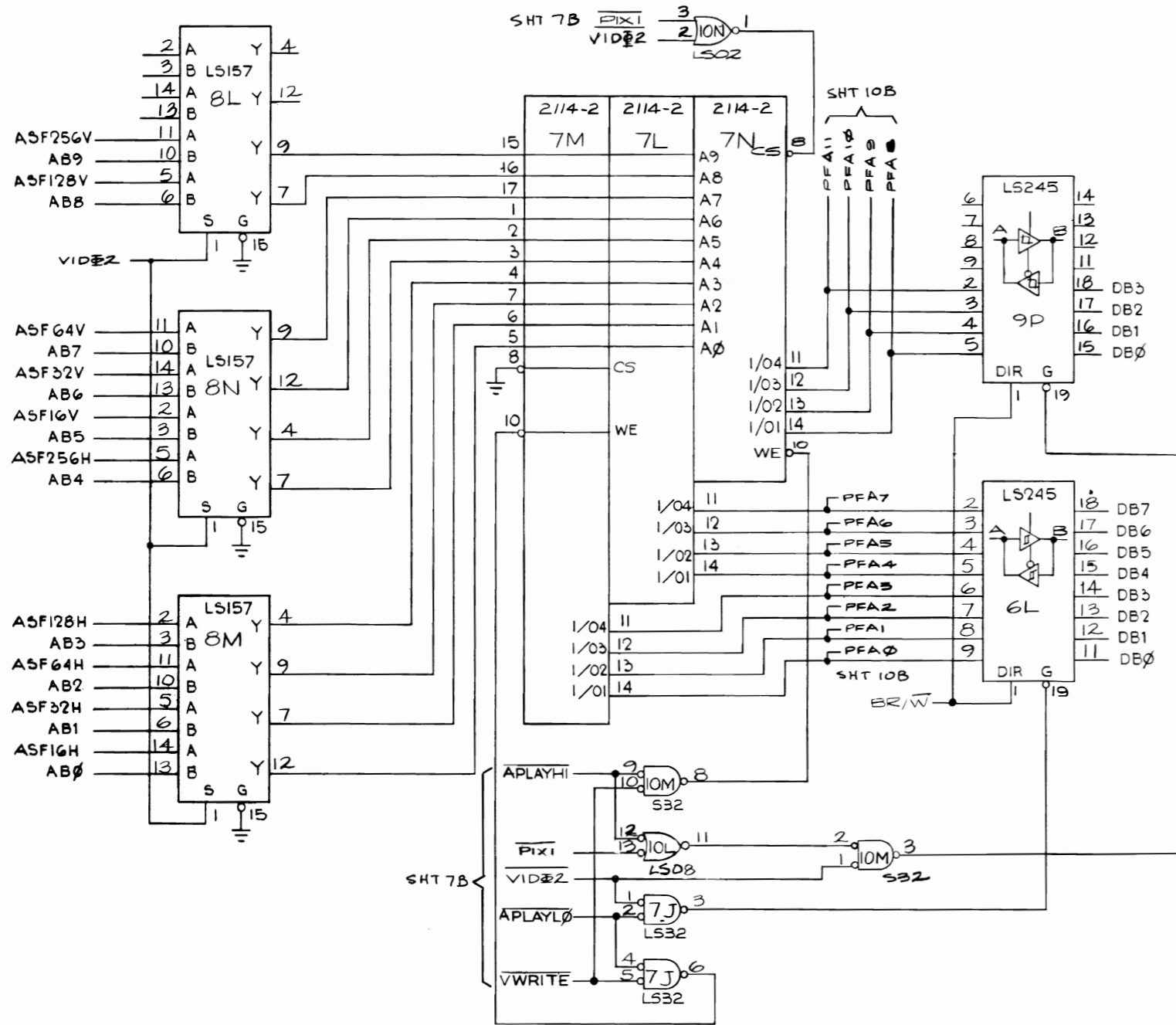

### Scrolling Playfield Horizontal and Vertical Registers

**NOTICE TO ALL PERSONS RECEIVING THIS DRAWING**  
 CONFIDENTIAL: Reproduction forbidden without the specific written permission of Atari, Inc., Sunnyvale, CA. This drawing is only conditionally issued, and neither receipt nor possession thereof confers or transfers any right in, or license to use, the subject matter of the drawing or any design or technical information shown thereon, nor any right to reproduce this drawing or any part thereof. Except for manufacture by vendors of Atari, Inc., and for manufacture under the corporation's written license, no right is granted to reproduce this drawing or the subject matter thereof, unless by written agreement with or written permission from the corporation.

### JEDI Game PCB Schematic



A Warner Communications Company

© ATARI INC. 1984

SP-227 Sheet 10A  
 1st printing

# Scrolling Playfield Graphic ROM

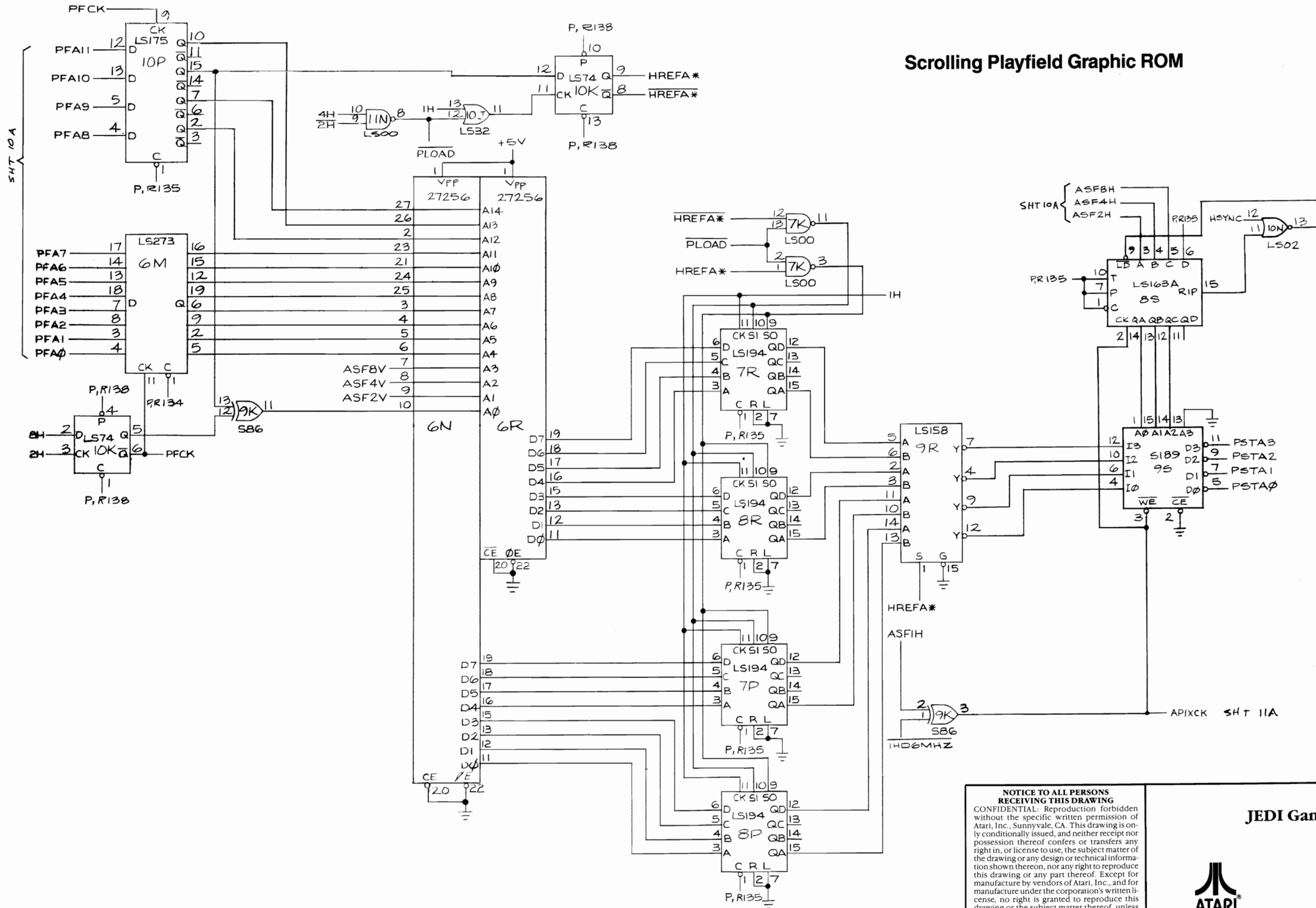

**NOTICE TO ALL PERSONS RECEIVING THIS DRAWING**  
 CONFIDENTIAL: Reproduction forbidden without the specific written permission of Atari, Inc., Sunnyvale, CA. This drawing is only conditionally issued, and neither receipt nor possession thereof confers or transfers any right in, or license to use, the subject matter of the drawing or any design or technical information shown thereon, nor any right to reproduce this drawing or any part thereof. Except for manufacture by vendors of Atari, Inc., and for manufacture under the corporation's written license, no right is granted to reproduce this drawing or the subject matter thereof, unless by written agreement with or written permission from the corporation.

**JEDI Game PCB Schematic**

  
 A Warner Communications Company

SP-227 Sheet 10B  
1st printing

© ATARI INC. 1984

### Scrolling Playfield Graphic Expander

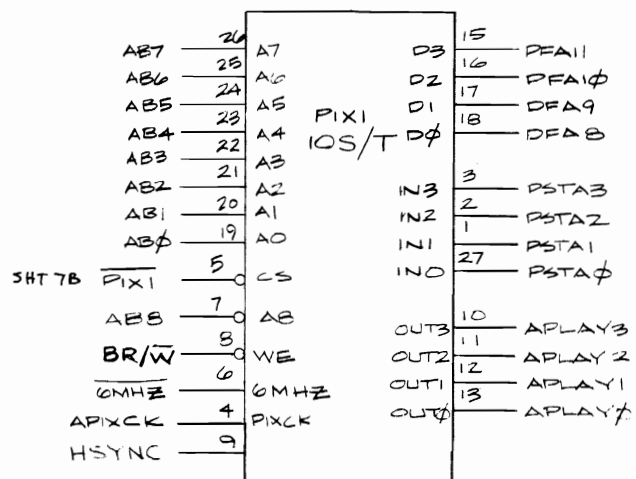

### Color RAM Multiplexers & Control Logic

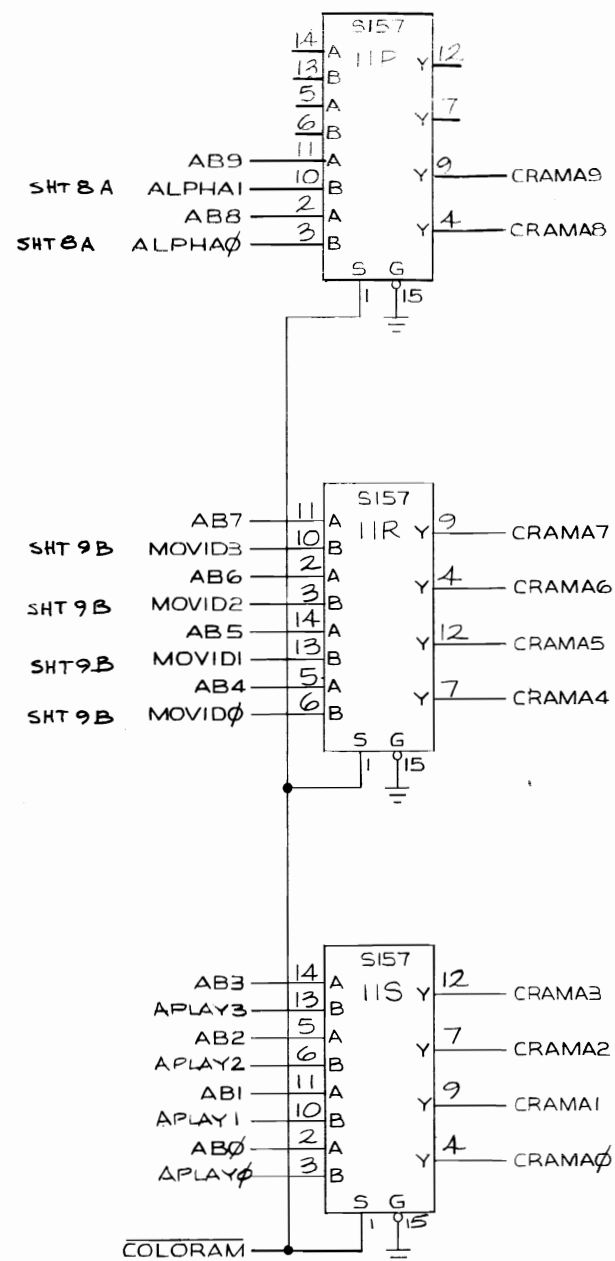

### Color RAM

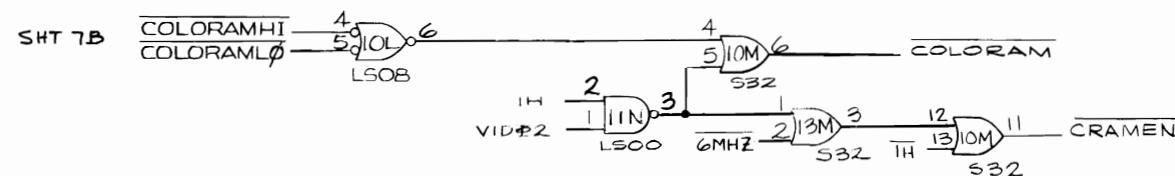
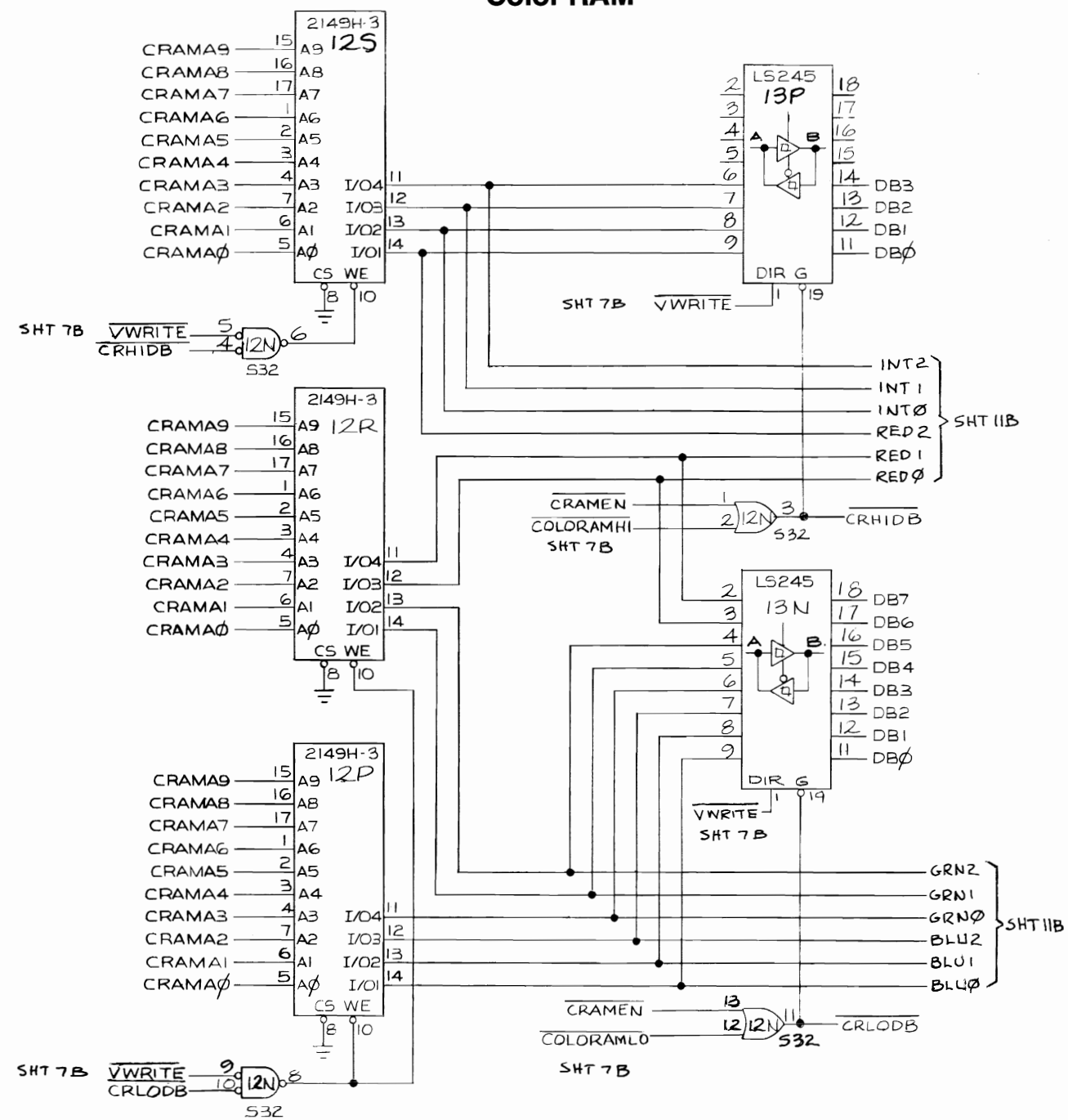

**NOTICE TO ALL PERSONS RECEIVING THIS DRAWING**

CONFIDENTIAL: Reproduction forbidden without the specific written permission of Atari, Inc., Sunnyvale, CA. This drawing is only conditionally issued, and neither receipt nor possession thereof confers or transfers any right in, or license to use, the subject matter of the drawing or any design or technical information shown thereon, nor any right to reproduce this drawing or any part thereof. Except for manufacture by vendors of Atari, Inc., and for manufacture under the corporation's written license, no right is granted to reproduce this drawing or the subject matter thereof, unless by written agreement with or written permission from the corporation.



**ATARI**

A Warner Communications Company

**JEDI Game PCB Schematic**

SP-227 Sheet 11A  
1st printing

© ATARI INC. 1984

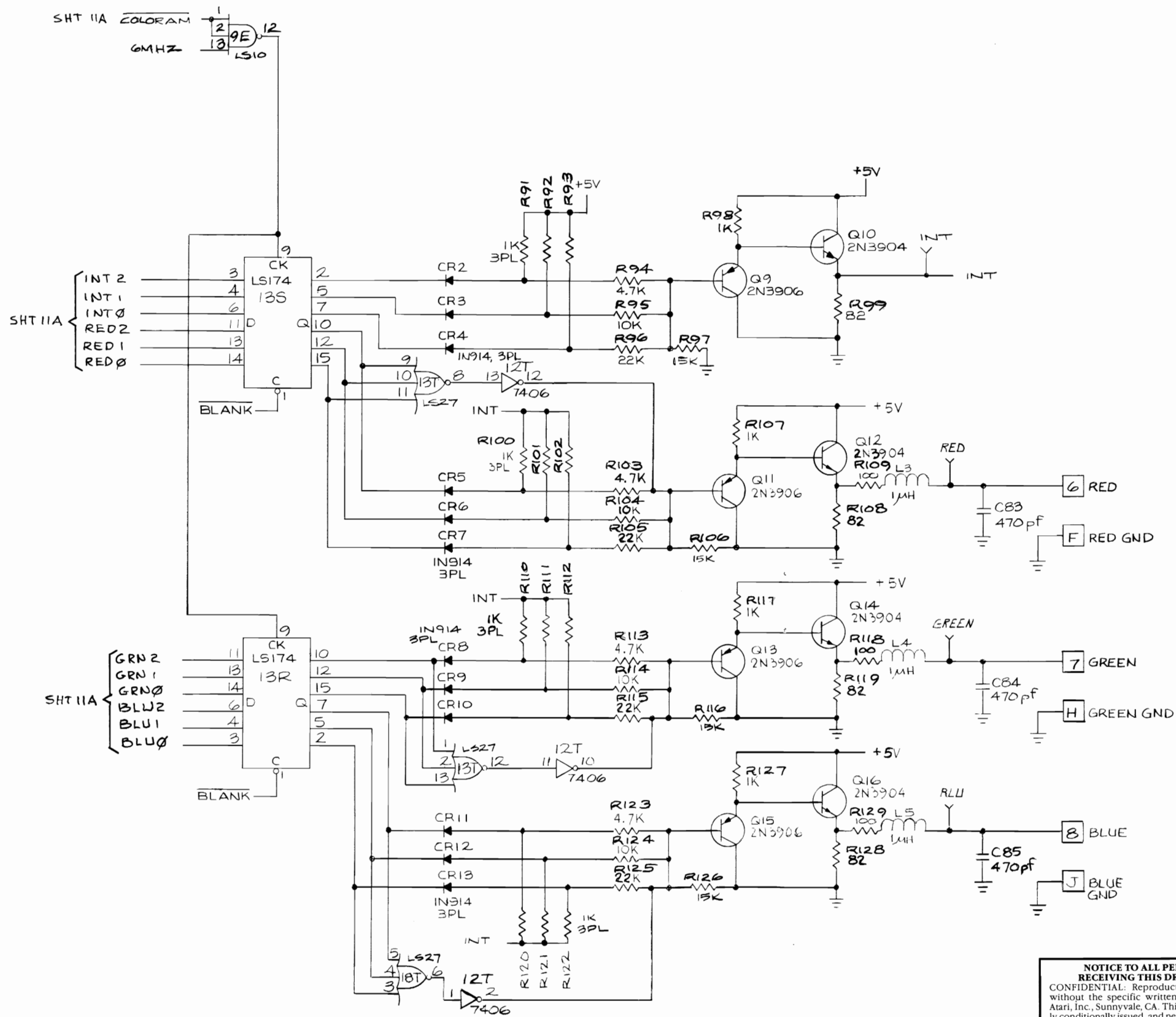

Color Output

**NOTICE TO ALL PERSONS RECEIVING THIS DRAWING**  
 CONFIDENTIAL: Reproduction forbidden without the specific written permission of Atari, Inc., Sunnyvale, CA. This drawing is only conditionally issued, and neither receipt nor possession thereof confers or transfers any right in, or license to use, the subject matter of the drawing or any design or technical information shown thereon, nor any right to reproduce this drawing or any part thereof. Except for manufacture by vendors of Atari, Inc., and for manufacture under the corporation's written license, no right is granted to reproduce this drawing or the subject matter thereof, unless by written agreement with or written permission from the corporation.

**JEDI Game PCB Schematic**



A Warner Communications Company

© ATARI INC. 1984

SP-227 Sheet 11B  
 1st printing

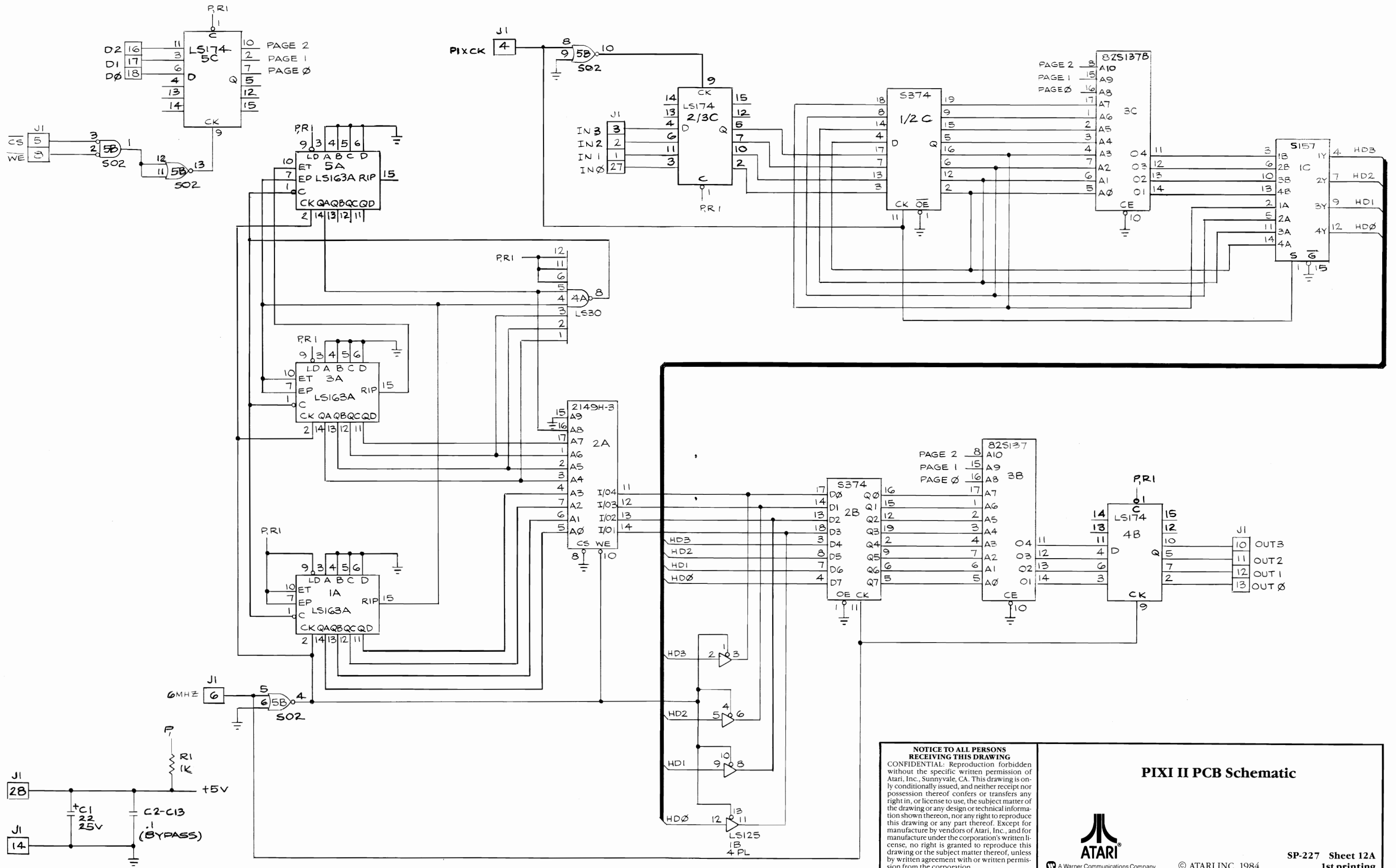

**NOTICE TO ALL PERSONS RECEIVING THIS DRAWING**  
 CONFIDENTIAL: Reproduction forbidden without the specific written permission of Atari, Inc., Sunnyvale, CA. This drawing is only conditionally issued, and neither receipt nor possession thereof confers or transfers any right in, or license to use, the subject matter of the drawing or any design or technical information shown thereon, nor any right to reproduce this drawing or any part thereof. Except for manufacture by vendors of Atari, Inc., and for manufacture under the corporation's written license, no right is granted to reproduce this drawing or the subject matter thereof, unless by written agreement with or written permission from the corporation.

**PIXI II PCB Schematic**

  
 A Warner Communications Company

© ATARI INC. 1984

SP-227 Sheet 12A  
1st printing