

This document has been downloaded from:



The largest resource for amusement machines
documentation on the world wide web!



FLIPPERSPILL.COM

REFERENCE MANUAL

centuri^{T.M.}
,INC.
HIALEAH . FLORIDA . U . S . A

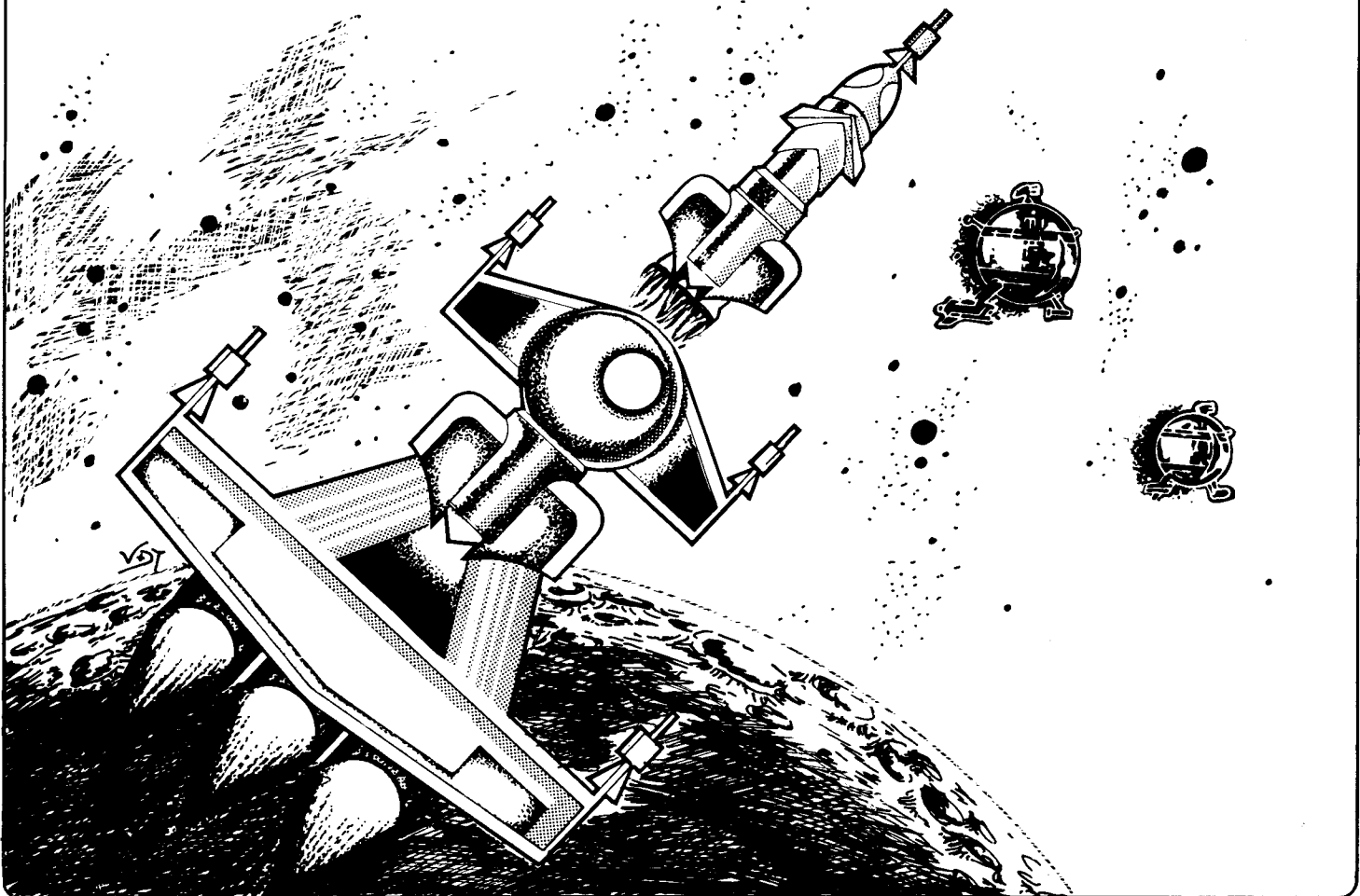

"EAGLE"

OPERATION AND MAINTENANCE
MANUAL

CENTURI, INC.

245 WEST 74TH PLACE

HIALEAH, FLORIDA 33014

TABLE OF CONTENTS

PAGE:

EAGLE UPRIGHT.....	1
INTRODUCTION.....	2
GAME PLAY.....	2, 3
EAGLE POINT SCORING.....	4
HIGH SCORE NAME REGISTRATION.....	5
METHOD OF REGISTRATION.....	5
INSTALLATION.....	6
ELECTRICAL REQUIREMENTS.....	6
MAINTENANCE AND SERVICE.....	6
GENERAL INFORMATION.....	7
OPERATOR OPTIONS.....	7
SWITCH OPTIONS.....	8
COLOR VIDEO MONITOR ADJUSTMENTS.....	9

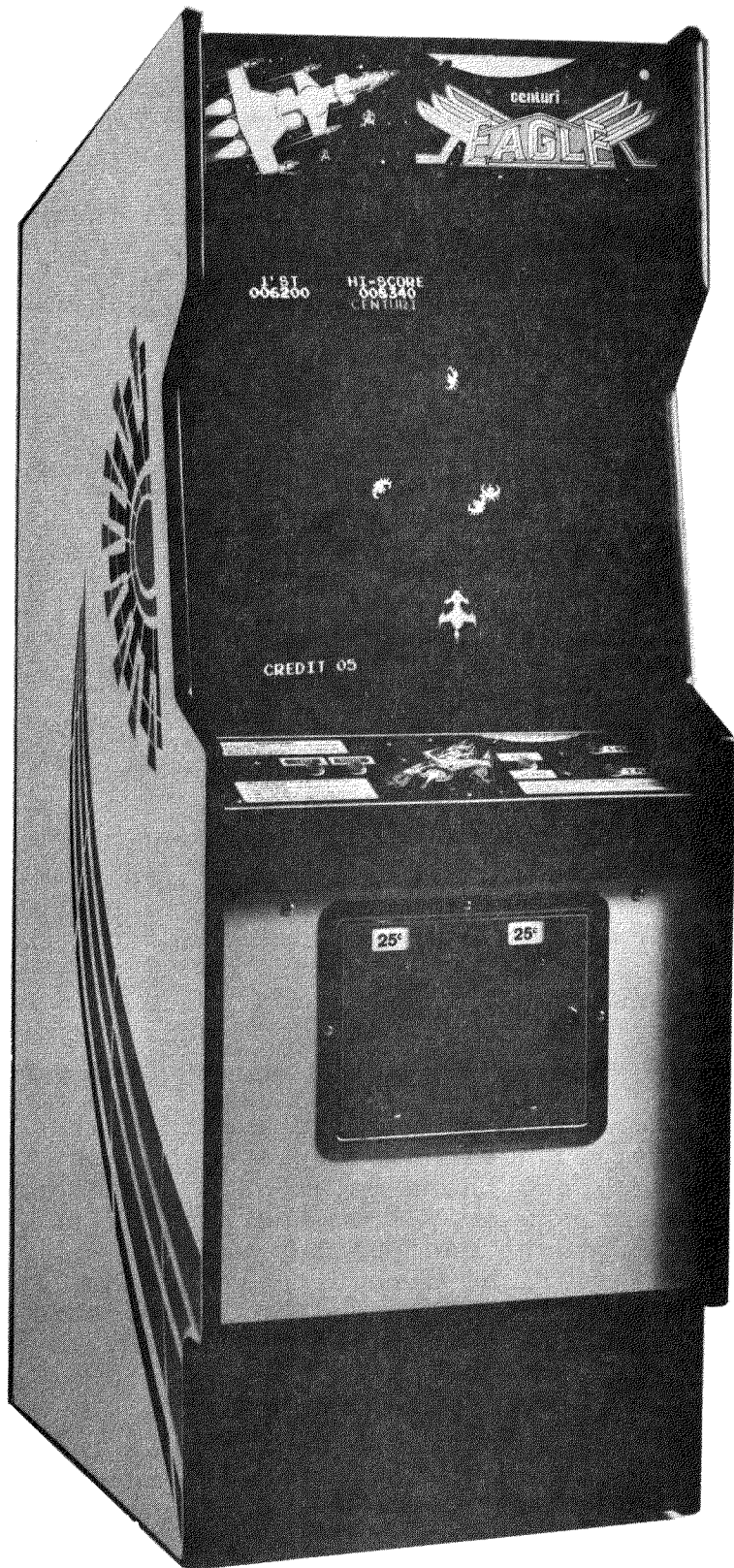

centuri
EAGLE

LAST SCORE
006200

HI SCORE
008340
CENTURI

CREDIT 05

25¢

25¢

INTRODUCTION

EAGLE is a one or two player action game that offers a mode of play designed to intrigue the player, and ensure prolonged interest.

The simplicity of control panel design, with the two button left/right directional control and the one button fire control, challenge the player's dexterity.

As the rocket is visually launched in the center of the screen, aliens attack the rocket enmass. As each wave attacks, the intensity of play increases. The player maneuvers his rocket to avoid collisions, and fires missiles to destroy the enemy.

A bonus feature of the game is the docking maneuver. Through use of the bidirectional control buttons, and the fire button as a retro control, the player can score extra bonus points by docking the rocket. The highest score is achieved by docking in the shortest period of time.

GAME PLAY

There are three modes of play in EAGLE:

- 1.) The Attract Mode
- 2.) The One-Player Mode
- 3.) The Two-Player Mode

The Attract Mode is activated when power is turned on. Initially, there is a video introduction to the game, then the top five high score names are registered. Next, the three stage rocket appears, with the explanation of the docking maneuvers with rockets I and II. After the docking maneuver, each stage rocket appears on the screen, and fires at waves of aliens until it is destroyed. The attract mode ends when all three stages of rocket are destroyed.

The One-Player Mode is activated when a coin is accepted and the player pushes the one-player button. The three stage rocket appears, and there is an audio introduction. The first stage rocket breaks away from the rest of the rocket, and play begins. The player manipulates the movement of the rocket by pushing the left/right directional buttons, and fires at the aliens with the fire button. The first stage rocket fires one missile at a time, until it is destroyed by the aliens. If the rocket destroys the first four waves of aliens, it encounters the first stage docking maneuver bonus. After it docks with the second stage rocket, then the rocket has the ability to fire three missiles at a time at the next two waves of aliens, and then the comet wave. The rocket is then able to try for the second stage docking maneuver bonus. After that is completed, the player then goes on to two additional waves. Having completed eight waves of aliens, one wave of comets, and two docking maneuvers, the program begins all over again, at a slightly faster rate of speed. When all three stages of the rockets have been destroyed

the game is over.

The Two-Player Mode is activated when a coin is accepted and the players push the two-player button. The pattern of play is identical to the pattern of play for the one-player mode, except that when the first player has his first stage rocket destroyed, the second player begins play with his first stage rocket. When the second player's first stage rocket is destroyed, then play reverts back to the first player, who will then have his second stage rocket to destroy the aliens. When his second stage rocket is destroyed, then the second player begins play with his second stage rocket. The same applies to the third stage rocket for both players. The game is over when both players have had all three stages of rockets destroyed.

EAGLE POINT SCORING:

	<u>NO. TARGETS:</u>	<u>POINT VALUE:</u>
Green Mantas:	4 Whole Targets that break in half when hit. Total = 8 Targets.	50 Points for each half destroyed.
Pink Mantas:	4 Whole Targets that break in half when hit. Total = 8 Targets.	50 Points for each half destroyed.
Pink Tegors:	8 Targets.	30 Points each.
Blue Tegors:	8 Targets.	30 Points each.
First Stage docking maneuver: 100 points per seconds remaining. Maximum points = 1900 points.		
Red Eagles:	8 Targets.	60 Points each.
Blue Eagles:	8 Targets.	60 Points each.
Comets:	8 Pair Targets = 16 Targets.	200 Points each.
Second Stage docking maneuver: 200 points per seconds remaining. Maximum points = 4200 points.		
Pink Volars:	8 Targets	100 Points each.
Green Volars:	8 Targets	100 Points each.
Program pattern then begins with the Mantas again, at a slightly faster rate of speed.		

HIGH SCORE NAME REGISTRATION:

The High Scorer's name can be registered on the screen.

Any unwanted wording can be cancelled by turning the game off at the service switch, and the high score will then be cancelled.

METHOD OF REGISTRATION:

1. The letters ("A"- "Z"), "Space", "Rub", and "End" will be displayed on the screen. By moving the control lever, move the underline through the alphabet one letter at a time, so that the high scorer's initials can be spelled.
2. A letter above the underline can be registered on the screen by pushing the fire button.

"RUB": If a wrong letter has been registered, move the underline to the word "Rub", then push the fire button and the letter will be cancelled.

"END": To finish the high scorer's initial registration, move the underline to the word "End" and push the fire button.
3. The high scorer's initial registration must be performed within one minute. After one minute has passed, the registration will automatically end. (In total, three letters can be registered).

INSTALLATION

Your game was shipped in ready-to-play condition. A brief visual examination is suggested after removal from the shipping carton.

Any damage to the game cabinet and external components should be noted for freight claim purposes. Any damage to the exterior would indicate possible interior damage as well.

Briefly examine the interior of the game for disconnected wires, cables or harnesses and electronic devices loose in their sockets, etc. Log the game serial number, as it will be required for reference and servicing.

ELECTRICAL REQUIREMENTS

Unless specified otherwise, your game is set to operate at 115VAC, 50/60 Hz. Two other voltage settings are possible, and these options and fusing requirements are listed on the power supply chassis.

A good ground is essential for the proper operation of this game. Instability and erratic operation can be traced to ineffective ground.

MAINTENANCE AND SERVICE

This machine should require very little maintenance and only occasional adjustments, due to the solid-state electronic circuitry.

Certain precautions should be observed to avoid damage to the game.

Service should be done by a qualified technician.

CENTURI Customer Service Department can be reached outside Florida at: #1-800-327-6749, or in Florida: #1-305-887-5528.

GENERAL INFORMATION

Your CENTURI game is designed much the same as other conventional video games. The game is built with the same basic assemblies:

The Power Supply unit provides all necessary voltages for each separate electronic assembly, as well as the AC lighting required throughout the game.

The Central Processing Unit (CPU or logic unit) contains the circuitry necessary to interpret all input functions which include the player control panel switches, all coin and credit information, and generates all the digital signals used to provide the visual display and control the audio effects. It also contains all the software (machine language and game personality memory) needed to control the game operation.

The Audio Control (volume control) is located on the main logic board, and can be easily adjusted by rotation of the volume pot. To maximize play time, the audio level should compete with the other machines.

OPERATOR OPTIONS

The option switch is located on the main logic board. See the Option Switch settings diagram for settings.

The option switch and audio control can easily be reached through the back of the game.

SWITCH OPTIONS

<u>SWITCH:</u>	<u>ON/OFF:</u>	<u>DESCRIPTION:</u>
1	OFF	Replay for 30,000 Points.
1	ON	Replay for 50,000 Points.
2	OFF	Japanese Docking Instructions.
2	ON	English Docking Instructions.
3	--	Not Used.
4	--	Not Used.

5	6	
OFF	OFF	1 COIN FOR 1 PLAY
ON	OFF	1 COIN FOR 2 PLAYS
OFF	ON	1 COIN FOR 3 PLAYS
ON	ON	FREE PLAY

COLOR VIDEO MONITOR ADJUSTMENTS

The video monitor is properly adjusted before shipping.

Occasionally adjustments are necessary and for this reason, a complete technical manual for the monitor is included with each game.

All adjustment control locations are located on the back of the monitor chassis.

Vertical Hold: Adjust vertical hold if picture rolls vertically.

Horizontal Hold: Adjust horizontal hold if the picture is warped or broken into diagonal lines. (Use caution when adjusting this control).

Focus: Adjust focus if picture is fuzzy.

Red, Green and
Blue Colors: Adjust red screen, green screen and blue screen controls.

For additional adjustments and information, refer to the monitor manual.

USER INFORMATION - F.C.C.

WARNING:

THIS EQUIPMENT GENERATES, USES AND CAN RADIATE RADIO FREQUENCY ENERGY AND IF NOT INSTALLED AND USED IN ACCORDANCE WITH THE INSTRUCTIONS MANUAL, MAY CAUSE INTERFERENCE TO RADIO COMMUNICATIONS. AS TEMPORARILY PERMITTED BY REGULATION, IT HAS NOT BEEN TESTED FOR COMPLIANCE PURSUANT TO SUBPART J OF PART 15 OF F.C.C. RULES, WHICH ARE DESIGNED TO PROVIDE REASONABLE PROTECTION AGAINST SUCH INTERFERENCE. OPERATION OF THIS EQUIPMENT IN A RESIDENTIAL AREA IS LIKELY TO CAUSE INTERFERENCE IN WHICH CASE THE USER AT HIS OWN EXPENSE WILL BE REQUIRED TO TAKE WHATEVER MEASURES MAY BE REQUIRED TO CORRECT THE INTERFERENCE.

INSTALLATION

Your game was shipped from the factory in ready-to-play condition. A brief inspection is suggested before the machine is removed from the carton. If there is damage to the shipping carton, contact the freight carrier for claim purposes. External damage could indicate possible damage to the cabinet and/or electronics components.

After the carton has been satisfactorily inspected, remove the machine from the shipping carton.

Examine the interior of the game for disconnected wires, cables, or harnesses. Make sure the electronic devices are securely mounted in their sockets, etc. Record the game serial number since it will be required for reference and servicing.

ELECTRICAL REQUIREMENTS

Unless otherwise specified, this game is set to operate at 110 Volts A.C. See Figure-1- for 110/220 VAC conversion instructions.

Power Supply Chasis schematic information and parts list are included in this manual.

FIGURE -1-

110/220 VAC CONVERSION INSTRUCTIONS:

This video arcade game has a harnessing configuration that allows the machine to be operated from either a 110 VAC or 220 VAC @ 50 or 60Hz power source, with only minor changes. The only items requiring a change are the fuses and the jumper plug on the game power transformer.

FIRST: Unplug the machine from the wall outlet to completely eliminate shock hazards.

SECOND: Remove the two fuses in the A.C. distribution bracket.

THIRD: Remove the jumper plug on the game power transformer located on the floor of the machine.

FOURTH: Depending on what voltage you wish to run the game from, do the following:

110 VAC

Replace the two fuses that go in the bracket with the 3 AMP, SLOW-BLOW types. Next, plug in the orange jumper plug labeled 110 VAC. The machine can now be operated with an input voltage of 110 Volts A.C.

220 VAC

Replace the two fuses that go in the bracket with 1½-AMP, SLOW-BLOW types. Next, plug in the red jumper plug labeled 220 VAC. The machine can now be operated with an input voltage of 220 Volts A.C.

NOTE: All games shipped from CENTURI, INC. are in the 110 VAC configuration.

ROUTINE MAINTENANCE & SERVICE

Because of the solid state electronic circuitry, this machine should require very little maintenance and only occasional adjustments. However, it is necessary to take measures to insure this.

The volume control is located on the bottom side of the printed circuit board farthest from the side of the cabinet, and can be accessed through the rear door.

The video monitor has been properly adjusted before shipping. Occasionally minor adjustments are necessary. See monitor specifications and schematics for technical information. Adjustment controls for the monitor are located at the rear of the monitor.

This machine should be serviced only by a qualified technician.

Do not make any adjustments on this machine while the power is on.

For service information, contact:

CENTURI, INC.

Customer Service Department

#800-327-7710 (Outside the state of Florida)

#305-556-5888 (In Florida)

POWER SUPPLY

The computer Board in this game operates most efficiently and reliably when the power supply is set so that the voltage on the board is 5.0 Volts, ± 0.1 Volts. To check this, place a meter across 5 Volts and ground at the edge connector. If necessary, adjust the screwdriver control on the power supply so the meter reads between 4.9 and 5.1 Volts.

PARTS LIST - SHINDENGEN POWER SUPPLY

<u>SYMBOL:</u>	<u>DESCRIPTION:</u>	<u>USAGE:</u>
T1	TRANSFORMER, SINGLE PHASE, 2A VA	1
L1	CHOKING COIL, 1.6mH, 1.5A	1
L2, L4	CHOKING COIL, SF-T8-50S-03	2
L3	CHOKING COIL, SF-HP-2A-03	1
D1	DIODE, V19G	1
D2	DIODE, V06C	1
D3, D6	DIODE, 1S1588	2
D4	DIODE, S15S3	1
D5, D7	DIODE, 5CH1M	2
D12, D13	DIODE, F113B	2
D14	DIODE, F113B	1
RF1	DIODE, S4VB40 (BRIDGE TYPE)	1
Q1	TRANSISTOR, 2SC2504	1
Q2	TRANSISTOR, 2SD467 (B)	1
Q3	TRANSISTOR, 2SC460 (B)	1
Q4	TRANSISTOR, 2SA673 (B)	1
IC1	INTEGRATED CIRCUIT, RM723DC or HA17723G-02	1
PC1	PHOTO COUPLER, PS2001	1
R1	RESISTOR, 2 WATT, 18 OHM	1
R8, R9	RESISTOR, 2 WATT, 47K OHM	2
R3, 1-4	RESISTOR, 2 WATT, 15 OHM	4
R4	RESISTOR, 1 WATT, 56 OHM	1
R12	RESISTOR, 1 WATT, 100 OHM	1
R28	RESISTOR, 1 WATT, 470 OHM	1
R7	RESISTOR, 1 WATT, 0.56 OHM	1
R26	RESISTOR, 1 WATT, 0.82 OHM	1
R23	RESISTOR, 1/4 WATT, 22 OHM	1
R10	RESISTOR, 1/4 WATT, 33 OHM	1
R27	RESISTOR, 1/4 WATT, 68 OHM	1
R2	RESISTOR, 1/4 WATT, 330-470 OHM	1
R22	RESISTOR, 1/4 WATT, 220 OHM	1
R21	RESISTOR, 1/4 WATT, 270 OHM	1
R6	RESISTOR, 1/4 WATT, 330 OHM	1
R11	RESISTOR, 1/4 WATT, 68 OHM	1
R20	RESISTOR, 1/4 WATT, 470 OHM	1
R17	RESISTOR, 1/4 WATT, 680 OHM	1
R19	RESISTOR, 1/4 WATT, 800 OHM	1
R18	RESISTOR, 1/4 WATT, 1.2K OHM	1
R5	RESISTOR, 1/4 WATT, 10K OHM	1
R16	RESISTOR, 1/4 WATT, 220K OHM	1
R29	RESISTOR, 3 WATT, 27 OHM	1
R39	RESISTOR, 1/4 WATT, 4.7K OHM	1
R38	RESISTOR, 1/4 WATT, 5.6K OHM	1
R24	RESISTOR, 1/4 WATT, 330 OHM	1
R25	RESISTOR, 1/4 WATT, 150 OHM	1
RV1	VARIABLE RESISTOR, RJ-6P501	1

PARTS LIST - SHINDENGEN POWER SUPPLY

<u>SYMBOL:</u>	<u>DESCRIPTION:</u>	<u>USAGE:</u>
C1, C2	CAPACITOR, ECK-DAL102E	2
C3-1,-2	CAPACITOR, 160VSN100	2
C9, C10	CAPACITOR, SM10VB-2200	2
C11, C23	CAPACITOR, SM10VB-2200	2
C12, C13, C15	CAPACITOR, SL25VB-10	3
C27	CAPACITOR, SL25VB-10	1
C18, C19, C20	CAPACITOR, SM35VB-1000	3
C26	CAPACITOR, SM35VB-1000	1
C21, C22, C25	CAPACITOR, SM16VB-1000	3
C5	CAPACITOR, DMY21H472K	1
C6	CAPACITOR, DMY21H104K	1
C14, C16	CAPACITOR, DMY21H222K	2
C4	CAPACITOR, CM20XC511K5	1
C8	CAPACITOR, MDD22G473K	1
C5-2	CAPACITOR, DMY21H222K	1
F1, F2	ENCLOSED TYPE FUSE, 3A	2

THE MATERIAL CONTAINED HEREIN IS CONFIDENTIAL AND NO PART OF IT CAN BE REPRODUCED WITHOUT THE EXPRESSED PERMISSION OF ALLIED LEISURE IND., INC.

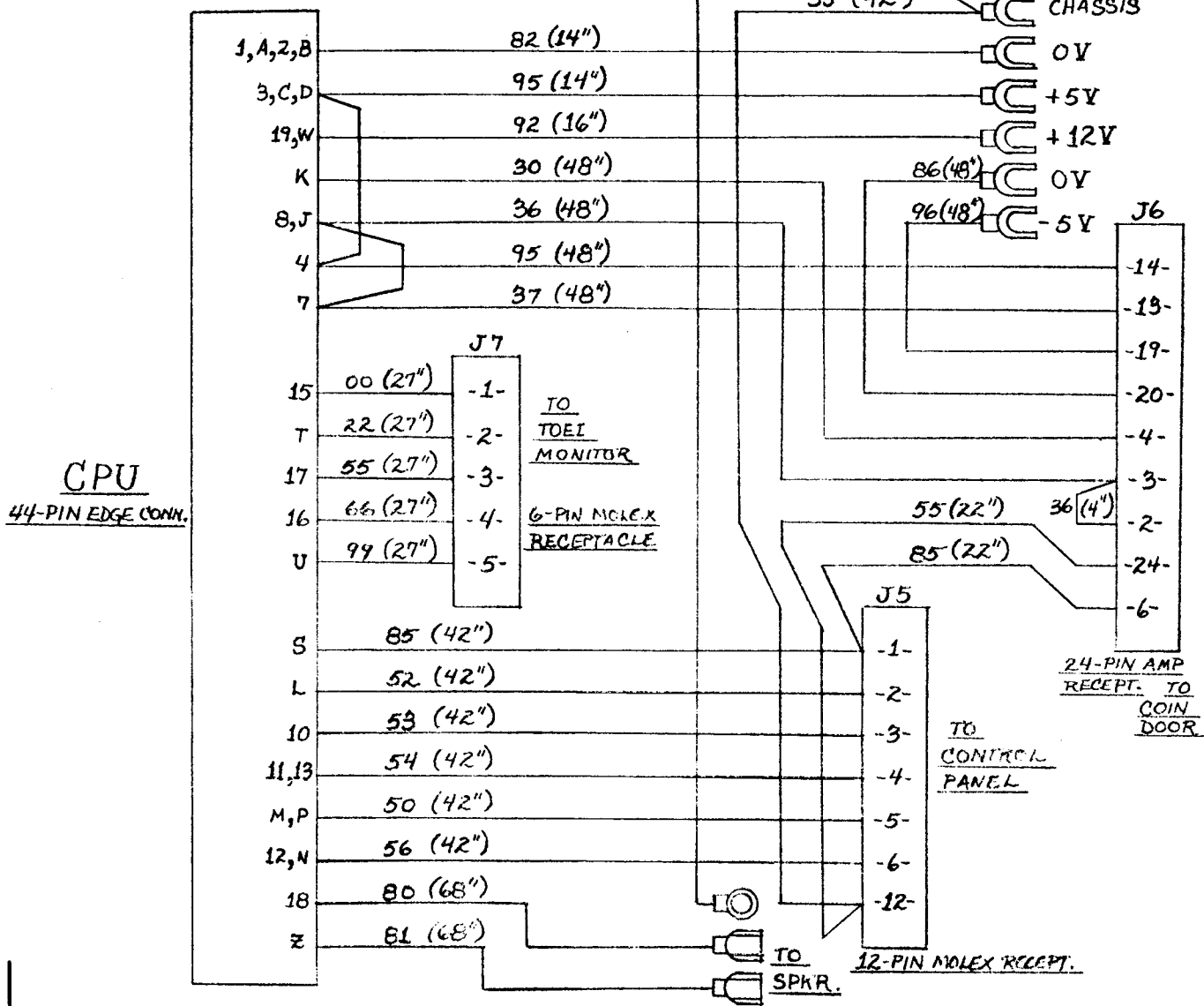

32			
31	48"	50179606	WHITE/BLUE STRIPE WIRE, #22 AWG
30	62"	50179506	WHITE/GREEN STRIPE WIRE, #22 AWG
29	16"	50179206	WHITE/RED STRIPE WIRE, #22 AWG
28	27"	50170006	WHITE WIRE, #22 AWG
27	48"	50178606	GRAY/BLUE STRIPE WIRE, #22 AWG
26	64"	50178506	GRAY/GREEN STRIPE WIRE, #22 AWG
25	14"	50178206	GRAY/RED STRIPE WIRE, #22 AWG
24	68"	50178106	GRAY/BROWN STRIPE WIRE, #22 AWG
23	68"	50178006	GRAY/BLACK STRIPE WIRE, #22 AWG
22	27"	50176606	BLUE WIRE, #22 AWG
21	42"	50175606	GREEN/BLUE STRIPE WIRE, #22 AWG
20	161"	50175506	GREEN WIRE, #22 AWG
19	42"	50175406	GREEN/YELLOW STRIPE WIRE, #22 AWG
18	42"	50175306	GREEN/ORANGE STRIPE WIRE, #22 AWG
17	42"	50175206	GREEN/RED STRIPE WIRE, #22 AWG
16	42"	50175006	GREEN/BLACK STRIPE WIRE, #22 AWG
15	48"	50173706	ORANGE/VIOLET STRIPE WIRE, #22 AWG
14	52"	50173606	ORANGE/BLUE STRIPE WIRE, #22 AWG
13	48"	50173006	ORANGE/BLACK STRIPE WIRE, #22 AWG
12	27"	50172206	RED WIRE, #22 AWG
11	27"	50179906	BLACK WIRE, #22 AWG
10	24	50270003	4" WIRE TIES
9	2	50150029	3/16" FAST-ONS
8	6	50150096	OPEN LUGS
7	1	50150105	RING LUG
6	12	50150223	MOLEX FEMALE PINS
5	9	50150269	AMP FEMALE PINS
4	1	50150262	6-PIN MOLEX RECEPTACLE
3	1	50150263	12-PIN MOLEX RECEPTACLE
2	1	50150268	24-PIN AMP RECEPTACLE
1	1	50150218	44-PIN EDGE CONNECTOR
ITEM	QTY.	PART NO.	DESCRIPTION

BILL OF MATERIALS

				TOLERANCES		ALLIED LEISURE INDUSTRIES, INC.				
				Unless Otherwise Specified		HIALEAH, FLORIDA 33014				
				FRACTIONS	± 1/32	NAME CPU HARNESS 19" EAGLE				
				DECIMALS 2 PL	± .015	MATERIALS				
				DECIMALS 3 PL	± .005	HEAT TREAT.				
				HOLES	± .003	FINISH				
				ANGLES	± 1/2°	DWN. DATE SCALE				
				SHT. MET BENDS	± 2°	APPD. DATE SCALE PART NO. 361-12-0300 REV.				
REV. LET.	ECN N	REVISION	BY							

THE MATERIAL CONTAINED HEREIN IS CONFIDENTIAL AND NO PART OF IT CAN BE REPRODUCED WITHOUT THE EXPRESSED PERMISSION OF ALLIED LEISURE IND., INC.

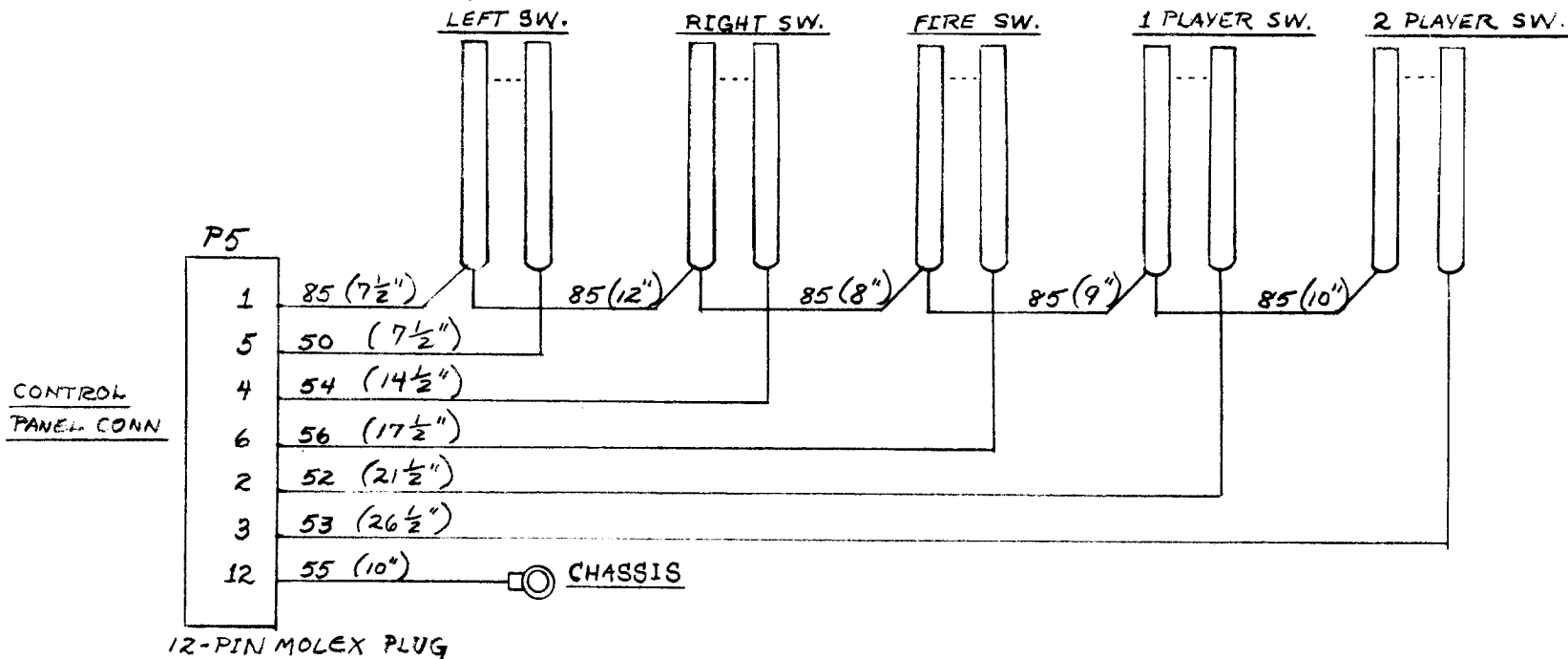

CONTROL
PANEL CONN

12-PIN MOLEX PLUG

6	22"	50155206	GREEN/RED STRIPE, #22AWG	11	47"	50158506	GRAY/GREEN STRIPE, #22AWG
5	8"	50155006	GREEN/BLACK STRIPE, #22AWG	10	18"	50155606	GREEN/BLUE STRIPE, #22AWG
4	7	50270003	4" WIRE TIES	9	10"	50155506	GREEN, #22AWG
3	1	50150105	RING LUG	8	15"	50155406	GREEN/YELLOW STRIPE, #22AWG
2	7	50150222	MOLEX MALE PINS	7	27"	50155306	GREEN/ORANGE STRIPE, #22AWG
1	1	50150261	12-PIN MOLEX PLUG				
ITEM	QTY.	PART NO.	DESCRIPTION	ITEM	QTY.	PART NO.	DESCRIPTION

BILL OF MATERIALS

BILL OF MATERIALS

QC. APVD	PROD. APVD	QTY.	ASSEMBLY ON
----------	------------	------	-------------

				TOLERANCES				ALLIED LEISURE INDUSTRIES, INC. HIALEAH, FLORIDA. 33014			
				Unless Otherwise Specified							
				FRACTIONS ± 1/32				CONTROL PANEL HARNESS			
				DECIMALS 2 PL ± .015							
				DECIMALS 3 PL ± .005				MATL' 361 EAGLE, 19" COLOR			
				HOLES ± .003							
				ANGLES ± 1/2°				DWN. JAB APP'D. DATE 10-5-81 SCALE 25 PART NO. 361-12-0400 REV.			
				SHT. MET BENDS ± 2°							
REV. LET.	ECN N	REVISION	BY								

A B C D E F

1
2
3
4
5
6
7
8

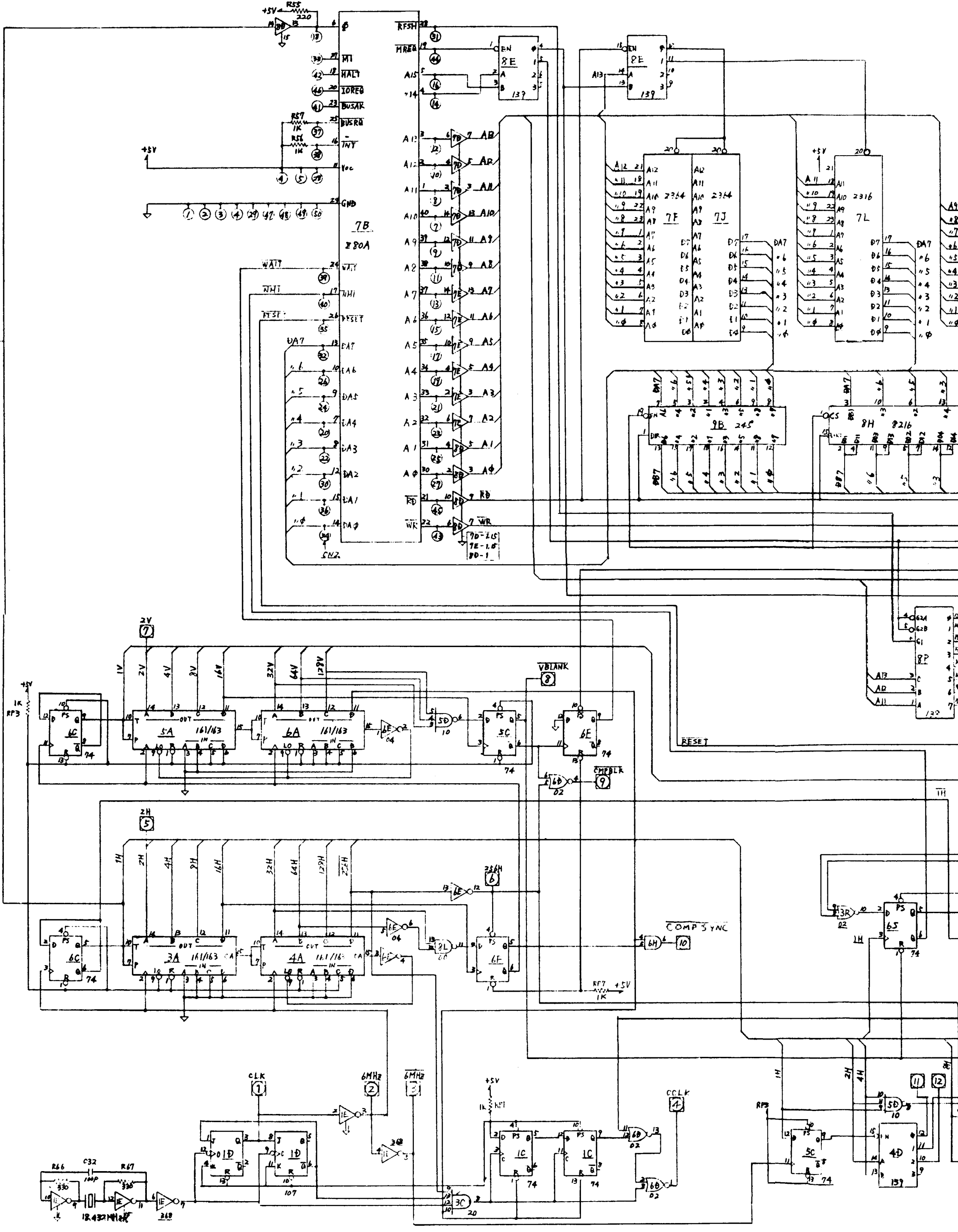

A B C D E F

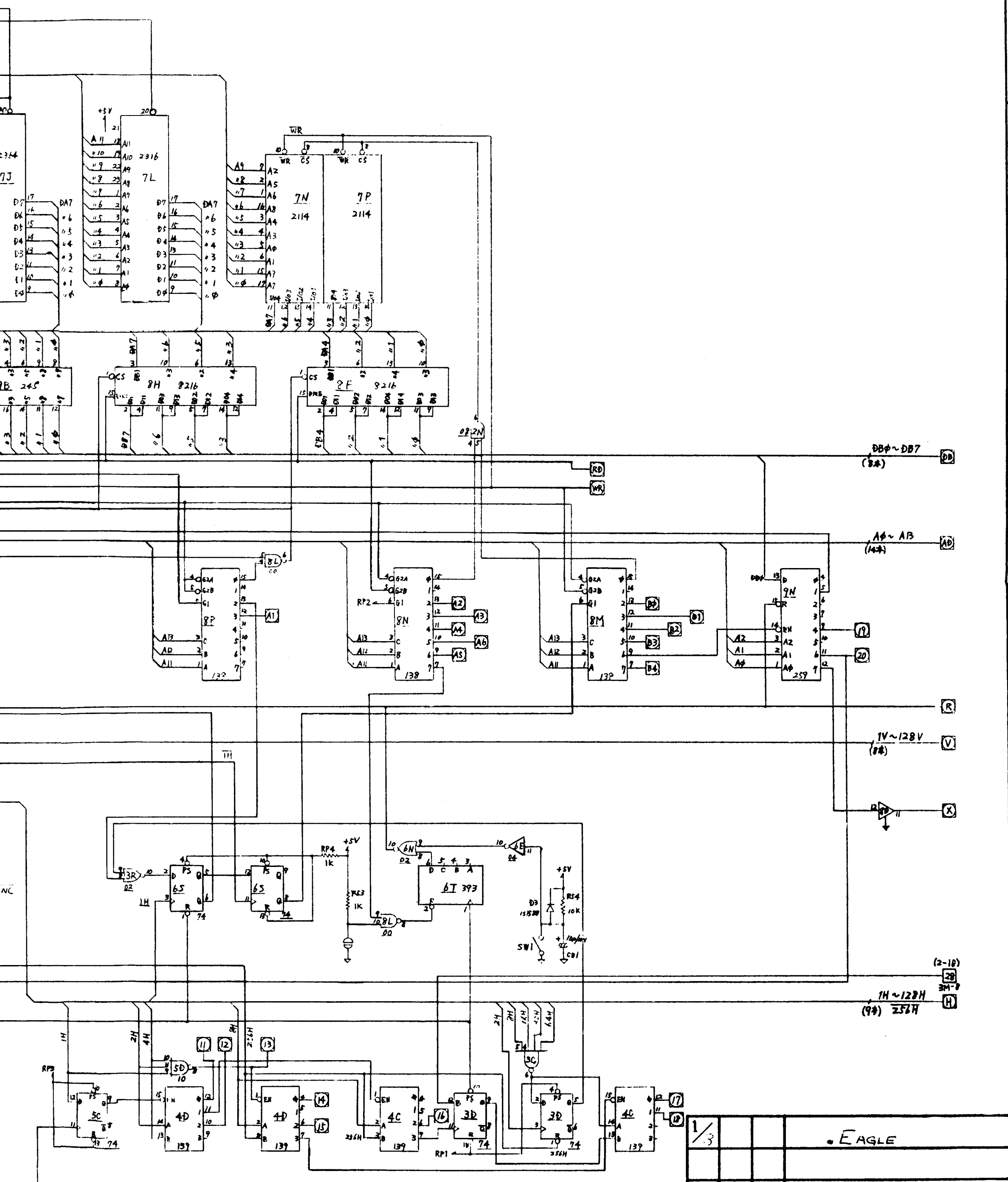

A B C D E F

1
2
3
4
5
6
7
8

(1-3D) AD A0~A13
1-4L

(1-6B) B 6E-12

(1-5L) 20 9N-11

(1-6B) H 1H~128H
1-7L 2356H

(1-6L) 90-11

(1-5B) V 1V~128V
1-6L

(1-3E) DB A0~7
1-4L

(1-5D) 9 6D-4

(1-7G) 12 40-10

(1-7G) 13 50-8
2 1E-3(1-7C)

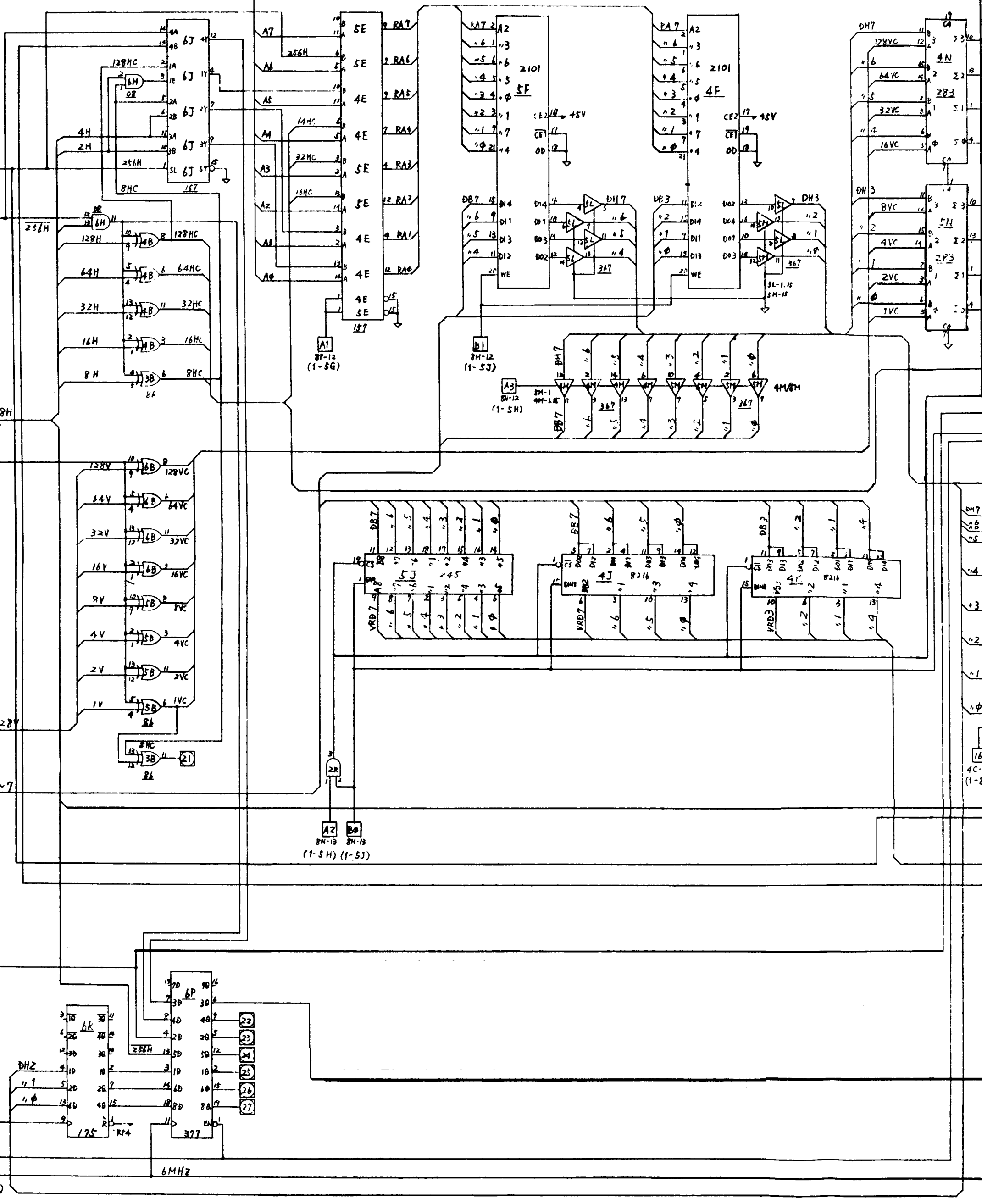

A B C D E F

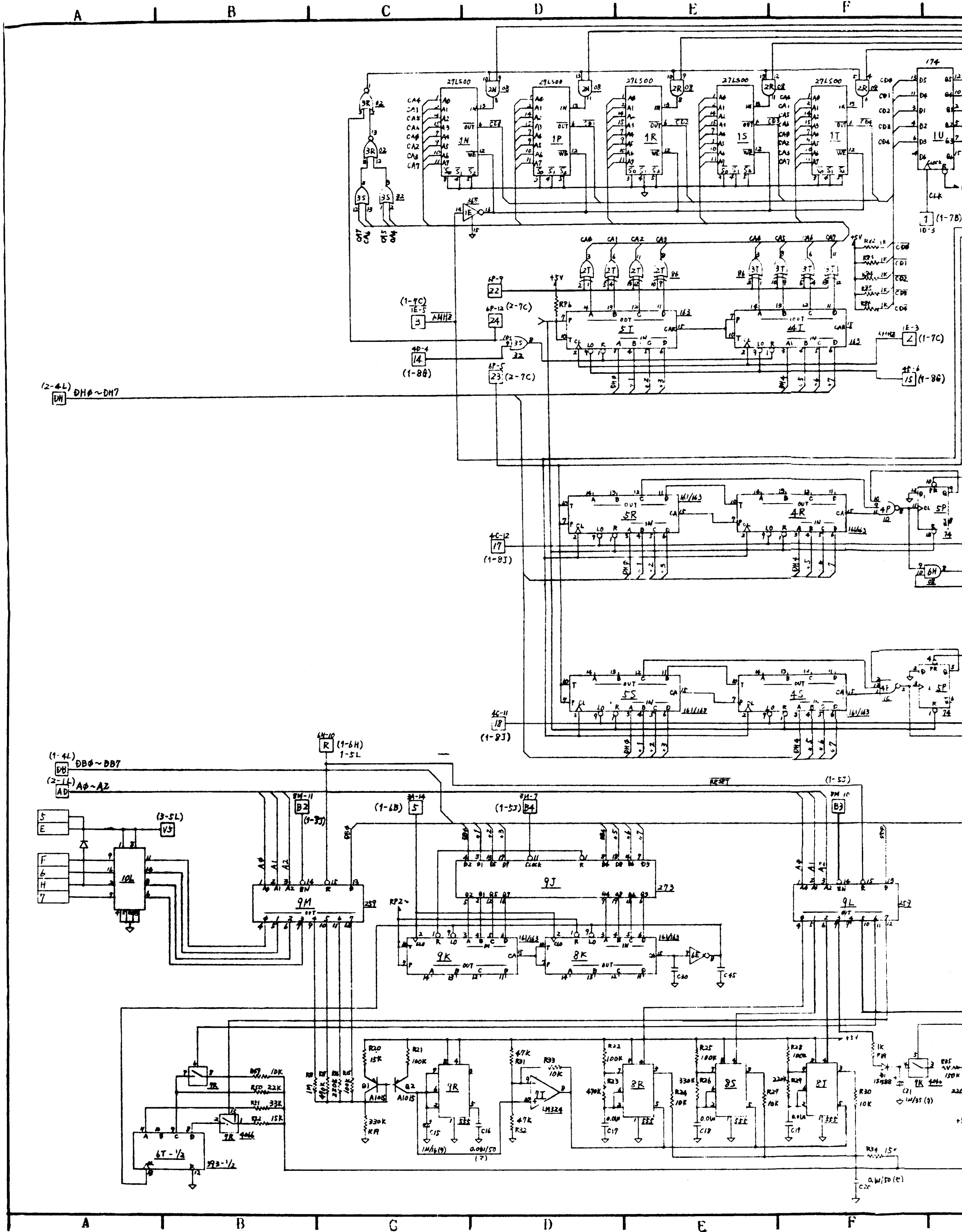

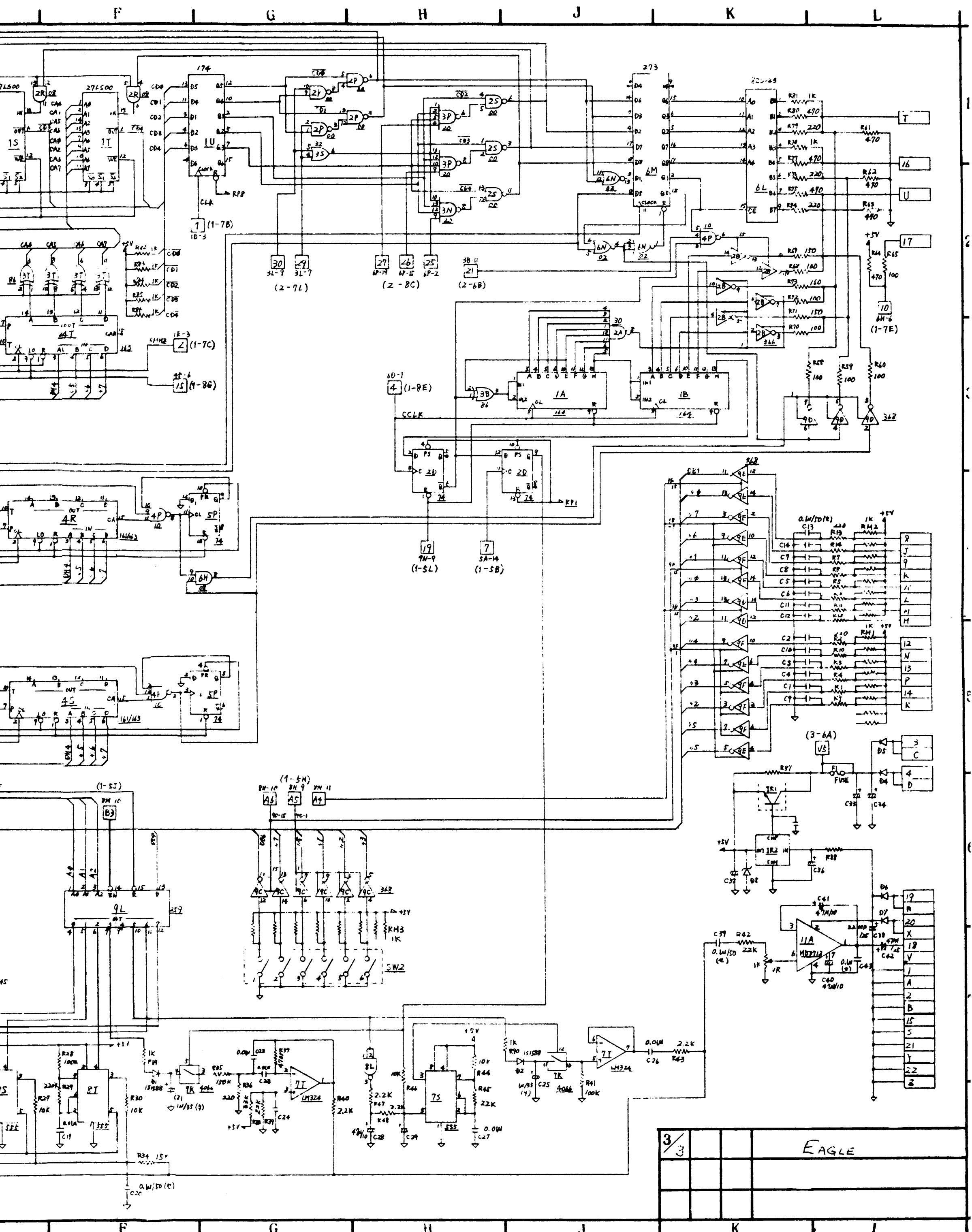

3	3	EAGLE	