

420-6942UK
1st Printing



SEGA AMUSEMENTS EUROPE LTD
Suite 3A, Oakes House, 12/22 West Street,
Epsom, Surrey. KT18 7RG. Tel: +44 (0) 1372 731 820

© SEGA CORPORATION, 2007

Lindbergh Universal Cabinet Upright Type

Manual

420-6942UK



M A N U A L

LINDBERGH™

UNIVERSAL CABINET

IMPORTANT

- Before using this product, read this manual carefully to understand the contents herein stated.
- After reading this manual, be sure to keep it near the product or in a convenient place for easy reference when necessary.

Warranty

The warranty period for this product is three months from the date of shipment from our premises. Within the warranty period, we will repair, free of charge, any fault occurring for reasons that are the responsibility of the manufacturer. If any fault occurs, stop using the affected product, remove the power plug from the outlet and contact the service contact specified at the back of the manual. This warranty is not applicable to faults occurring for any of the reasons listed below (repairs, if possible, will require payment).

- (1) Faults caused by natural disaster or other act of God.
- (2) Faults caused by flooding, or by damage from falling.
- (3) Faults caused by incorrect operation.
- (4) Faults caused by usage that contravenes the installation conditions or specification conditions specified in this manual.
- (5) Changes caused by modifications to equipment specifications (addition to, or alteration of, the equipment), where not specified by this company.
- (6) Faults caused by the user, whether by accident or design.
- (7) Faults caused by failure to service the machine (maintenance and inspection) at the required intervals.
- (8) Overhauls, regular maintenance, movement and re-installation of large machines.
- (9) Faults caused by the machines other than this product.
Malfunctions (screen display disturbance etc.) caused by electrical noise generated by other machines.
- (10) Components that are deemed to be consumable supplies.
 - i) Fluorescent tubes and lamps
 - ii) Switches and buttons
 - iii) Levers and joysticks
 - iv) Fuses and other components
 - v) Standing displays, flags and other promotional materials
 - vi) Items specified in this manual to be consumable supplies
- (11) Network faults not caused by the product.
 - i) Network environment on the premises (LAN cables, switching hubs etc.)
 - ii) Circuits, providers and other elements of the Internet environment
 - iii) Server failure and similar incidents

The warranty period of chairs, cabinet stands and other options provided with this product may differ from that of the product itself.

This company bears no liability of any kind for loss of profits or indirect damages resulting from the inoperability of this product.

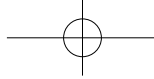

Table of contents

Warranty

Read this first

Table of contents..... i

Introduction to this manual iii

1 Handling precautions.....1

2 Installation location precautions4

3 Operation precautions6

4 Part names8

5 Accessories9

6 Installation and assembly procedure11

6-1 Installation work.....11

6-2 Precautions on using a service outlet16

7 Precautions when moving the console.....17

8 Internal switches and the coin meter18

9 For mounting the control panel20

9-1 Replacing the control panel.....20

9-2 Replacing the instruction sheet.....23

10 The coin selector.....24

11 The monitor (LCD display)27

11-1 Safety precautions for handling the monitor27

11-2 Cleaning the screen surface28

11-3 Monitor adjustment method.....29

12 Replacing the fluorescent lamp.....43

13 Replacing the game board45

13-1 How to remove the game board.....45

13-2 Replacing the design components.....47

13-3 The game board power supply voltage adjustment knob.....49

14 Regular inspection list.....50

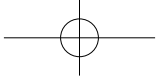

Table of contents

15	Parts list	51
16	Wire color reference table	80
17	Overall wiring diagrams.....	81

Introduction to this manual

This manual provides information and detailed explanations on the

LINDBERGH UNIVERSAL CABINET

including electronic assemblies, electrical mechanisms, maintenance management, spare parts and all other operation-related matters.

This manual is intended to be read by the owners, managers and operators of this product. Before using this product, read the manual and be sure that you understand it thoroughly. If this product does not operate correctly, contact the service contact stated in this manual, and make sure nobody other than the appropriate technician touches any internal systems. When requesting mechanical repairs or purchasing parts (consumable supplies), fill in and fax the “On-site service request form”, “Service components order form” or “Advance loan and repair request form”. If you lose this manual, use the “Service components order form” to obtain a replacement. This manual does not cover compensated accidents involving personal injury or property damage, but important information is bounded by a thick line and marked with the word “Important” and icons.



IMPORTANT

Incorrect operation which fails to follow these indications can impair the performance of this product or prevent it from functioning at all.

Specification

Area required:	820mm (W) x 827mm (D)
Height:	2,097 mm
Weight:	122kg (with Lindbergh board mounted)
Power consumption, maximum current:	460W, 2A (AC230V, 60Hz) (When using Virtua Fighter)
Monitor:	32V wide-screen LCD display

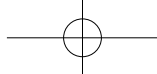

Definition of maintenance staff and service engineers

WARNING

Tasks in this manual which are specified to be performed by on-site maintenance staff or service engineers, and tasks which are not explained by the manual, should not be attempted by anyone who lacks the necessary level of knowledge and skill. Electric shocks or other serious accidents could result.

Replacement of parts, maintenance and inspection, and repairs to malfunctions should be performed by on-site service staff or service engineers. This manual directs that hazardous tasks, in particular, should be performed by service engineers with the necessary specialist knowledge.

This manual defines on-site maintenance staff and service engineers as follows

:

On-site maintenance staff: A person with experience of the maintenance of amusement machines and vending machines etc., who is involved in the day-to-day maintenance of equipment in an amusement arcade or store, under the management of the owner or operator of this product. Tasks include assembly and installation of machines, maintenance and inspection, and the replacement of units and consumable supplies.

On-site maintenance staff perform the following tasks:

Assembly and installation of amusement machines and vending machines etc., maintenance and inspection, and the replacement of units and consumable supplies.

Service engineer:

A person involved in the design, manufacture, inspection and maintenance servicing of machines for an amusement machine manufacturer. A technical high school graduate or person with equivalent specialist knowledge in electrical, electronic and mechanical engineering, who is engaged in the maintenance management and repair of amusement machines on a day-to-day basis.

Service engineers perform the following tasks:

Assembly and installation of amusement and vending machines, repair and adjustment of electrical, electronic and mechanical components.

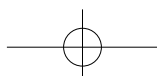

1 Handling precautions

When installing and inspecting this product, pay close attention to the following points and handle the machine accordingly, to allow safe gameplay.

Improper handling, in contravention of the points below or of the precautions stated in this manual, can cause personal injury and mechanical damage.

WARNING

- **Always turn the power switch off before working on the machine. Electric shocks or short-circuit accidents could result.**
The manual will always state when it is necessary to work on the machine with the power switched on.
- **Do not plug in or unplug the power plug suddenly. Electric shocks or other accidents could result.**
- **Do not plug in or unplug the power plug with wet hands. Electric shocks accidents could result.**
- **Do not leave power or earth cables exposed in aisles and other areas where people walk. Exposed cables could be damaged, leading to electric shocks or short-circuit accidents.**
- **Do not place objects on top of the power cable, or otherwise damage it. Electric shocks or fires could result.**
- **Do not pull on the power cable unnecessarily, either during or after installation. Electric shocks or fires could result.**
- **If the power cable is damaged, order a replacement from the vendor, or from the office stated in this manual. Continued use with a damaged power cable could cause fire, electric shock or ground leakage.**
- **A ground connection is required. Electric shocks could result without appropriate grounding.**
- **Use fuses of the specified rating. Use of a fuse in excess of the specified rating could result in fire or electric shock.**
- **The IC board and other connectors must be fully connected. If they are not fully inserted, they could cause electric shocks.**
- **Never make any changes (additions or alterations) to the specification defined by the manufacturer.**
 - **Electric shocks or fires could result. Such changes could also cause the user of the product, or others nearby, to feel unwell or suffer accidental injury.**
 - **This company bears absolutely no liability, including for compensation to third parties, for accidents that occur involving a product that has been altered from its standard specification.**
- **Always perform regular servicing (Maintenance and inspection) as specified in this manual.**
- **The current capacities for game boards in this product are 3.3V 12A, 5.0V 15A, 12V 10A. Never use game boards which require capacity above these values. Use of such boards would cause overheating and ignition.**

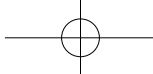

IMPORTANT

1 Handling precautions

- Only a logic tester should be used for circuit inspection on IC boards. Note that normal circuit testers cannot be used.
- Use a soft, dry cloth for cleaning the surface of the monitor. Do not use chemicals such as thinners or benzene.
- Static charge from the human body can damage electrical components on an IC board. Before starting work on an IC board, always touch a grounded metal surface, or take other action to discharge static electricity from your body.
- Some of the components used in this product were not designed and manufactured specifically for it. The manufacturers of such components may, for their own reasons, alter the specifications of those components, or cease manufacturing them. In such cases, it may become impossible to repair or replace them, either during or after the warranty period.

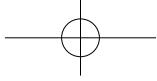

Labels

Our products have a label affixed to them stating the product serial number and electrical specification. Another label states the service contact for requesting repairs and ordering parts.

When requesting repairs or making other inquiries, check the serial number and model name before calling. The serial number references registered information about the product. Even for machines of the same model, the parts used may differ depending on the time of production. The product may also have been altered for improvement after this manual was published. Please state the serial number when contacting us, to enable a rapid response in such cases.

Warning indications

Our products carry adhesive or attached labels or printed markings in places where there is a potential hazard, to warn of the risk. These warning indications are intended to prevent customers from suffering accidents, and to avoid risks related to maintenance work.

Some areas within the cabinet, such as high-voltage parts, can cause accidents when touched. Pay close attention to warning indications when servicing the product. In particular, repair or replacement tasks not described in this manual should only be attempted by a service engineer with electrical knowledge. Customers acting in contravention of warnings should stop such actions, to avoid accidents.

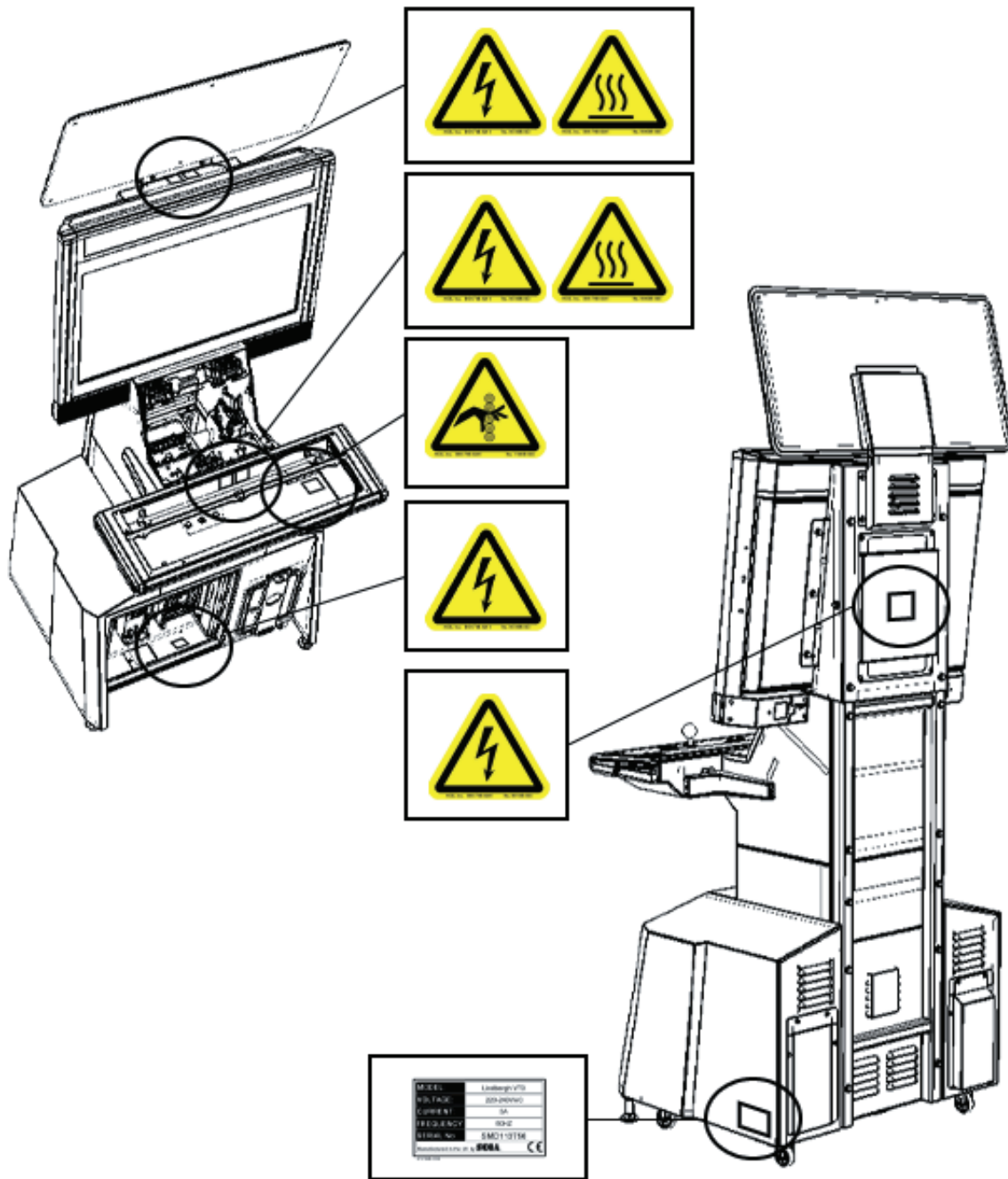

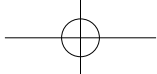

2 Installation location precautions

WARNING

This product is a game machine for indoor use. Do not install it outdoors. Even indoors, do not install it in places such as the following: Such locations can cause fire, electric shock, injury and breakdowns.

- Areas exposed to leakage of rain or other water, or in very humid places, such as close to an indoor pool or shower.
- Areas exposed to direct sunlight, close to heating equipment, or other hot places.
- Areas filled with flammable gas, or near to chemicals or hazardous substances that are highly flammable or volatile.
- Areas with high dust concentrations.
- Inclined surfaces.
- Areas of intense vibration.
- Close to safety equipment such as emergency exits and fire extinguishers.
- Areas outside the appropriate usage temperature (ambient temperature) range of 5-30 °C.

Limits of usage conditions

WARNING

- Always check the electrical specifications.
Always check that the power source, voltage and frequency where the product is installed match the specification. A label stating the electrical specification is affixed to the product.
Use with a different electrical specification can cause fire and electric shock.
- The installation location must be equipped with a breaker and ground connection for the product. If it is not used with its own breaker and ground connection, fire and electric shock could result.
- Indoor wiring to the product should be single-phase 100V AC with capacity for at least 15A 240V AC with a capacity of 13A. Use with a different electrical specification can cause fire and electric shock.
- Always provide the product with a dedicated power supply that has a ground-fault interrupter. If the power supply used does not have a ground-fault interrupter, a fire could result from a ground fault.
- Do not attempt to clean this product using high pressure equipment such as a jetwash.
- Do not connect multiple devices through extension cables and taps. Excessive electrical load can cause overheating and fire.
- When an extension cable is used, it must be rated at 13A or more. Use of a cable below of the specified rating could result in fire or electric shock.

Operating floor area

WARNING

- When this product is in use, it requires an area with a minimum width of 0.9m, and a depth of 1.6m. If a user falls over during play and bangs his or her head, it could cause major damage, so the area specified in this manual is absolutely necessary.
- Always provide the ventilation space specified in this manual. Do not block the ventilation holes. Overheating and fire could result.
- This company bears absolutely no liability, including for compensation to third parties, for accidents that occur when the product is used in an area smaller than that specified in this manual.



IMPORTANT

Door dimensions of at least 0.9m wide and 1.8m tall are required for moving this product into the building.

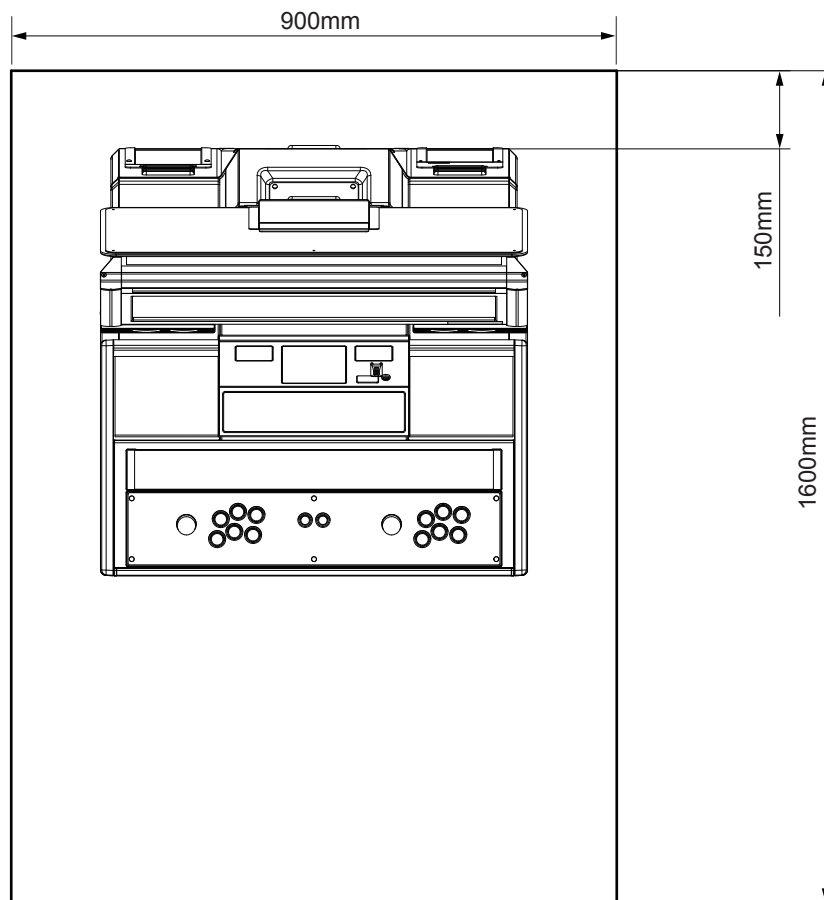
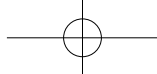

Figure 2

WARNING

To prevent accidents, allow sufficient space where this product is installed, to accommodate busy times. If there is not enough space, customers could contact or bump into each other, causing accidents and problems.



3 Operation precautions

WARNING

Before starting to operate this product, check the following points to prevent accidents:

- Operate this product under illumination that is sufficiently bright for reading the warning indications, to avoid causing dizziness, headache or other symptoms in players or other customers. Inadequate lighting could cause users to feel unwell, and could also cause incidents due to contact or collision between customers.
- Be sure to adjust the monitor correctly. Do not operate the monitor with noise or distortion in the image. An incorrectly adjusted screen image can cause dizziness, headache or other symptoms in players or other customers.
- Provide rest facilities for use by any player who feels unwell.
- Check that all adjusters are touching the ground. If they are not, the cabinet could move and cause an accident.

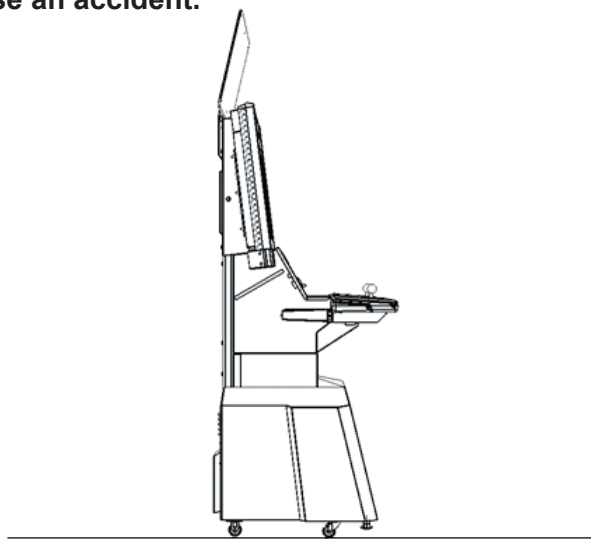

Please ensure that the leg adjusters are in contact with the floor and the casters are raised approx 5mm off the surface.

- Do not place heavy objects on top of this product. Falling objects or damage to components could result.
- Do not climb on top of this product. Falling or tipping accidents could result. Use a step ladder to inspect high parts.
- Check that none of the doors or covers are broken or missing. Electric shocks accidents could result.
- Do not place any objects such as the following on this product, on or inside the control panel, on the seat, on the ceiling or nearby: Electric shocks, short-circuit accidents or damaged components could result.
Flower vases, plant pots, cups, water containers, cosmetics, chemicals or containers holding water etc.
- This product is only for use in the European Union. Use of this product overseas could cause accidents or damage.

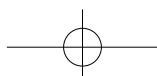

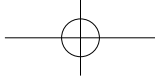

Operating precautions (customer-related precautions)

WARNING

- Do not allow the following types of people to play on this product. Accidents or injuries could result.
 - People who cannot walk unaided.
 - Hypertension and heart disease patients.
 - People who have experienced muscle spasms or loss of consciousness while playing television games etc.
 - People with neck or spinal diseases.
 - People strongly under the influence of alcohol.
 - Pregnant women.
 - People who experience motion sickness.
 - People who act in contravention of the warning indications on the machine.
- People who never felt unwell as a result of light stimuli, but whose physical condition may cause symptoms such as dizziness or headache while playing.

In particular, young, developing children are very likely to feel unwell while playing, so instruct such children that they can only play under the supervision of a parent or guardian.
- Advise those who have begun to feel unwell to undergo a medical examination.
- Make sure heavy objects and drinks are not placed on top of this product. They could result in accidents due to falling objects and electric shock accidents due to spilt drinks.
- Do not allow people to insert hands, fingers or foreign objects carelessly into the openings or door gaps of this product. Electric shocks or short-circuit accidents could result.
- Immediately stop anyone who leans or climbs on this product. It could tip over, or the person could fall.
- Do not allow people to unplug the power plug. Electric shocks or short-circuit accidents could result.

NOTE

- Immediately stop anyone who hits, kicks or otherwise uses violence on this product. It could break or tip over, and broken parts or the falling machine could cause injury.

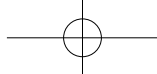

4 Part names

4 Part names

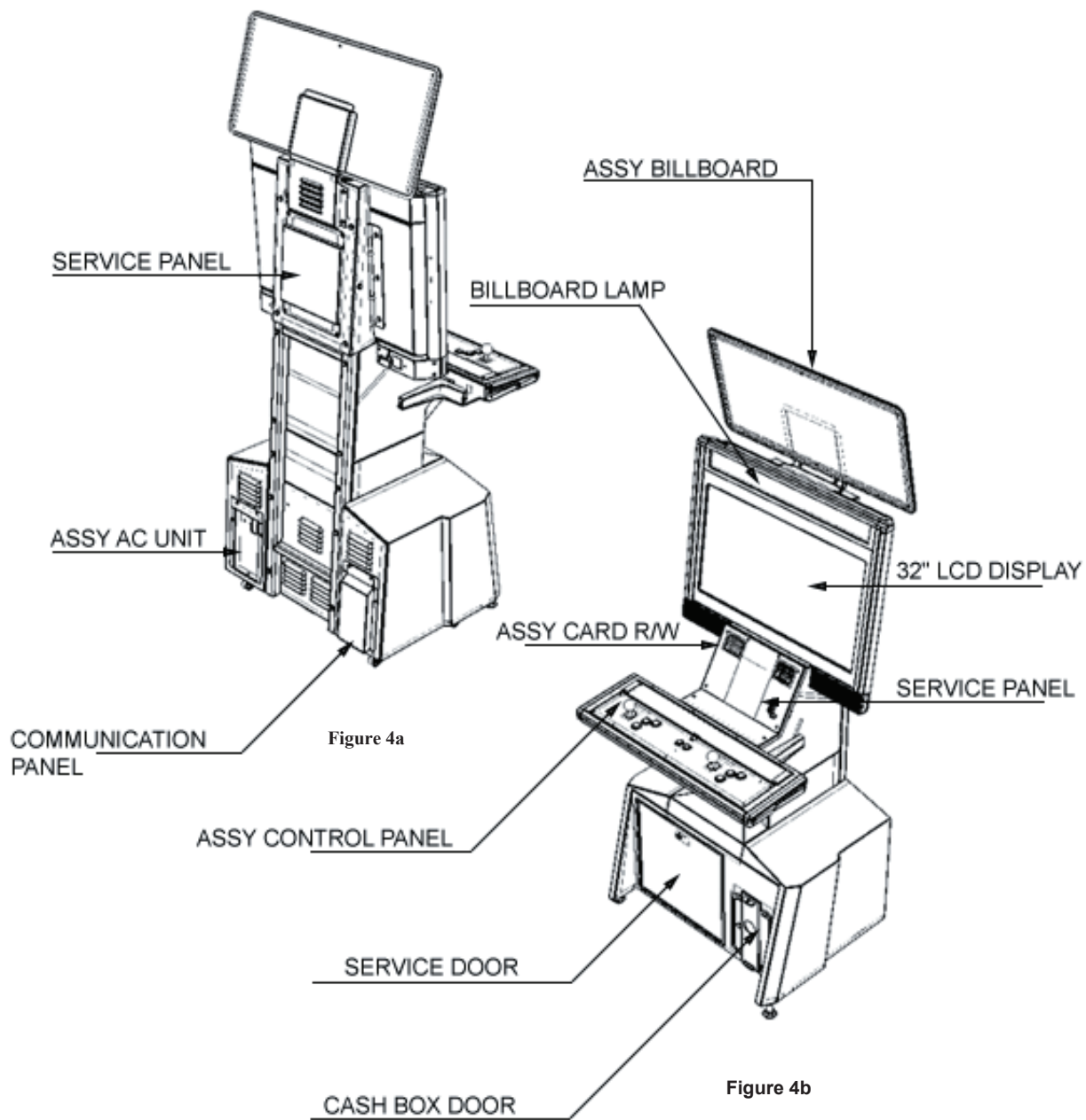
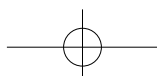

Table 4 Main dimensions

	Dimension
Cabinet	820 mm(W) x 827 mm(D) x 1,800 mm(H)
Complete cabinet	820 mm(W) x 827 mm(D) x 2,100 mm(H)



5 Accessories

Check that all the parts listed below are present when delivered. Parts marked as “Spare” in the Application etc. column are consumable parts, but are provided as spares. Refer to the back cover for consumable parts other than those in this table.

Replacement harnesses

This is an accessory which varies according to the game which is installed when the machine is shipped. The replacement harnesses listed below may be packed with this product as an accessory, to make it usable with our Naomi/2 or Lindbergh. They will already be installed if the machine is shipped with game boards of those types. In future, replacement harnesses other than those below may be provided as accessories.

1 For Naomi, Naomi2. : LCA-60027
 1 For Lindbergh. : LCA-60028

Table 5 List of accessories

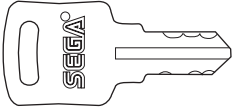
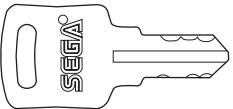
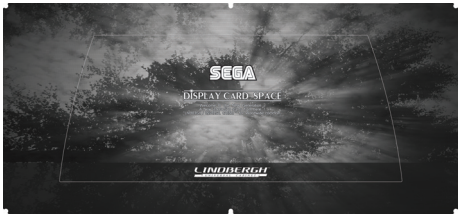
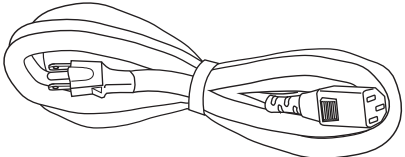
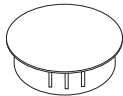
<p>Part name Instruction manual Part number (Q'ty) 420 - 6942UK (1) Application etc. This manual Explanatory diagrams Parts with no stated part number have either not been registered with parts, or cannot be registered. Store such parts carefully because it may not be possible to sell them even if the user wishes to purchase them.</p>	<p>Master key To open and close door</p> 
<p>Billboard sheet LCA-0002 (1) The billboard may be already attached or packaged separately, depending on the game which is installed when the machine is shipped.</p>	<p>Key (2) For the cashbox door</p>  <p>Attached to the inside of the service door when shipped.</p>
	<p>Anti-bacterial cap switch 253-5442 (6) For the control panel, see chapter 9.</p>
<p>Power cable 600-6729-01 (LM1227 & LM1246) For installation, refer to 6-13 3</p> 	

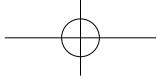

Instruction sheet



The control box may be already attached or packaged separately, depending on the game which is installed when the machine is shipped.

Sub-instruction sheet



The entry lid may be already attached or packaged separately, depending on the game which is installed when the machine is shipped.

6 Installation and assembly instructions

6-1 Installation work

WARNING

Install this product as described in this manual. Improper installation may result in personal injury and mechanical damage.

Installation of this product consists of the following three main steps:

- 1 Billboard attachment
- 2 Fastening in the installation location (adjustment of the adjusters)
- 3 Connection of power supply and ground connections

Tools required for installation

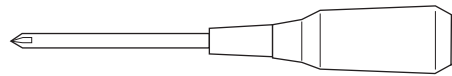

Philips screwdriver (for M4 screws)

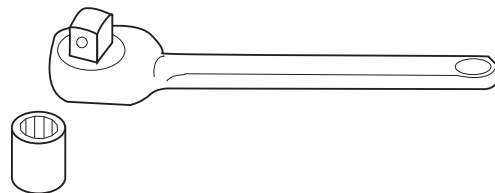

Socket wrench
(for M6 hexagonal bolts and nuts)

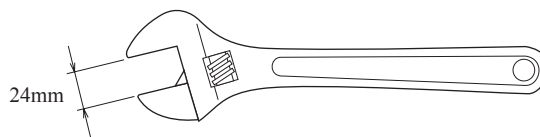

Spanner (for M16 hexagonal bolts)

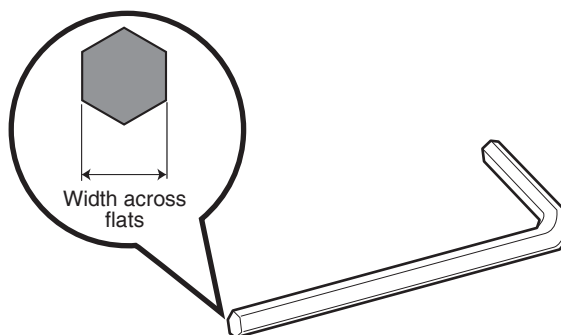

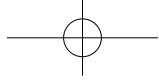

1

Attaching the billboard

1

Use four hexagonal bolts to attach the billboard holder to the cabinet.

6

Installation and assembly instructions

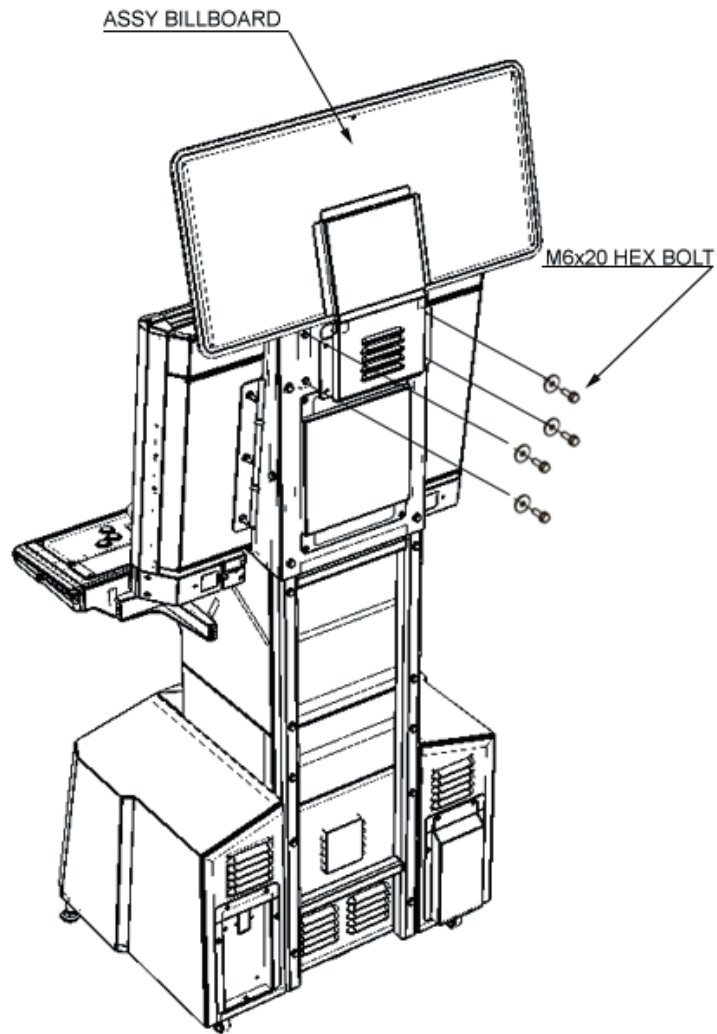
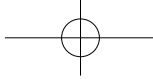

Figure 6.1a



2 Fastening in the installation location (adjustment of the adjusters)

WARNING

Make sure all adjusters touch the floor. If they do not, the cabinet could move and cause an accident.

There are four casters and four adjusters on the bottom of the cabinet. Once the installation position is determined, move the adjusters down to the ground and adjust them so that this product is level.

1 Move the machine to the installation position.

2 Bring the adjusters into contact with the ground. Use a spanner to adjust the four adjusters so that the product is held level.

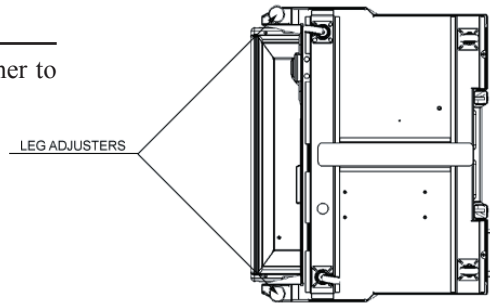

Figure6.1c Underside plan

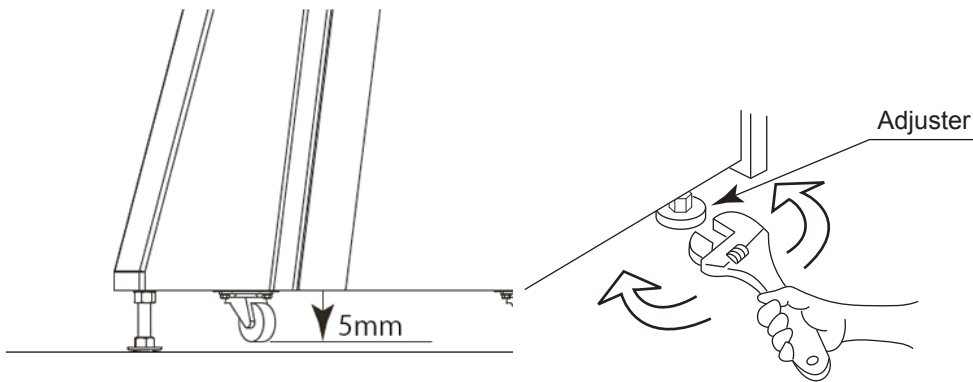

Figure6.1c Underside plan

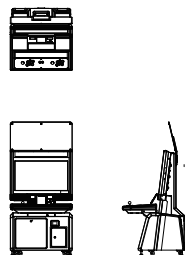

Figure 6.1e
1/100 scale.
Refer to the layout leading to the installation position.

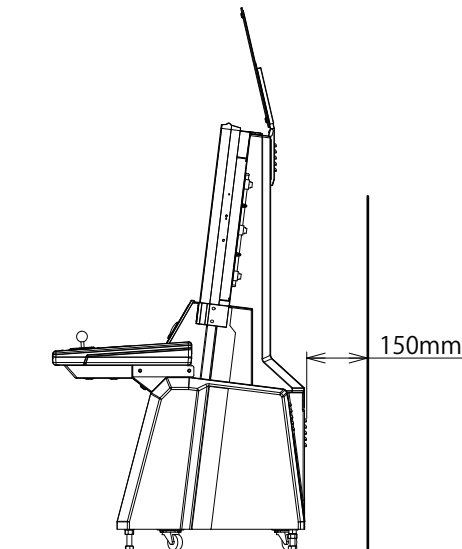
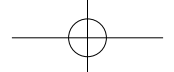

Figure 6.1f
Allow space for air movement on the side with ventilation openings.



3 Connection of power supply and ground connections

WARNING

- Use a power supply equipped with a ground fault interrupter. If the power supply used does not have a ground-fault interrupter, a fire could result from a ground fault.
- This product comes complete with both UK and European mains leads. Only operate this product with the mains leads supplied or mains leads of the same type and rating. Using mains leads other than those supplied or mains leads of a different rating may result in electric shock, short circuit or a fire hazard.
- Do not leave power cables exposed. Exposed cables could trip people and suffer damage. Electric shocks or short-circuit accidents could result from damaged cables. Run cables where they will not impede people's movement, or cover them.
- Always protect any cable that runs across the floor. If the power cable is exposed, it will be vulnerable to damage and could cause electric shock accidents.

There is an AC bracket at the back of the machine. It has a Mains Switch (ON/OFF), a protection fuse and an inlet for connecting power cables.

- 1 Check that the main switch is switched off.

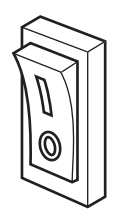

Main switch off

Figure 6.1g

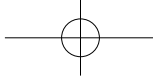

- 2** Plug the power plug of the power cable securely into the socket, and plug the connector opposite the plug securely into the inlet of the AC unit.
- 3** Connect the power cable (and grounding cable). Attach a wiring cover to protect the power and earth cables.

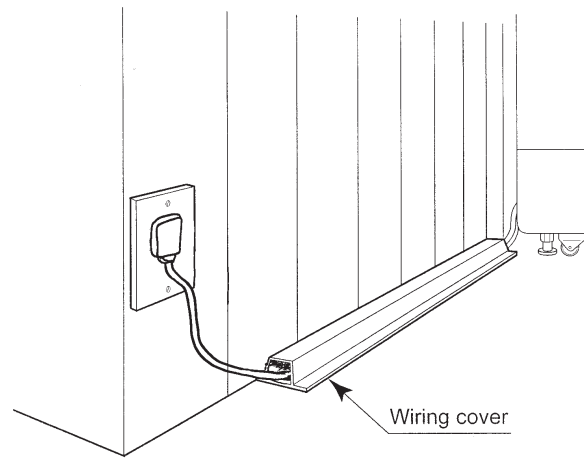
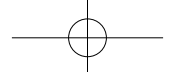

Figure 6.1i



6-2 Precautions on using a service outlet

WARNING

The current capacity of the service outlet on the machine is 5A. Overheating and ignition could result if devices with combined maximum current in excess of 5A are connected to the service outlet. That is a very dangerous situation, which must be avoided.

It is not possible to connect one Lindbergh-equipped cabinet to the service outlet of another, as the maximum current capacity would be exceeded.
Head-to-head connection of one additional cabinet is possible, provided it is not a Lindbergh cabinet.

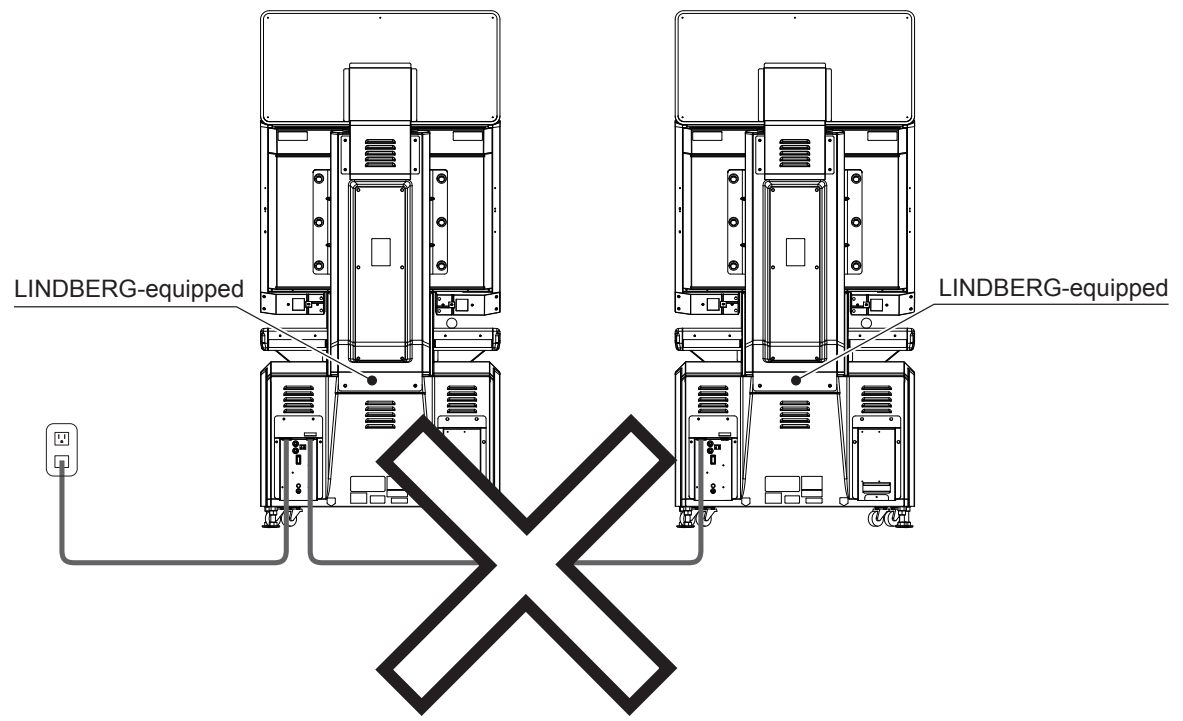

Figure 6.2

7 Precautions when moving the console

WARNING

- Unplug the power plug before moving the machine. Moving the machine with the plug plugged in could damage the power cable and cause fire and electric shock. Take care not to damage the cable by treading on it or trapping it while moving the machine.
- Do not push strongly on the top of the cabinet. That could tip the cabinet forward and cause an accident.

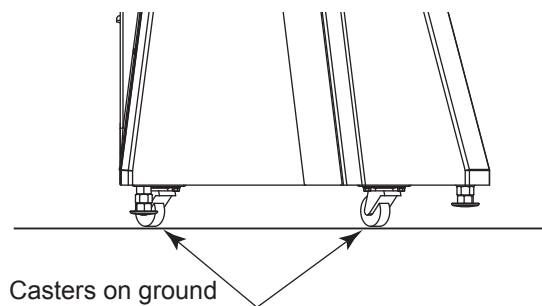
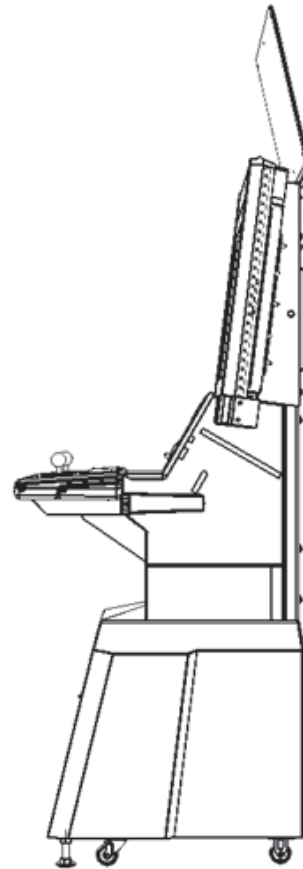
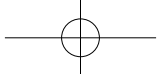

Figure 7a





8 Internal switches and the coin meter

WARNING

- Never touch places other than those specified. Touching other places could cause electric shock or short circuit accidents.
- Take care not to damage the wiring. Electric shocks or short-circuit accidents could result from damaged wiring.



IMPORTANT

Adjust the volume to an appropriate level for the surroundings.

The entry lid opens when the lock on the back is unlocked. When the entry lid is open, the internal switches can be seen inside.

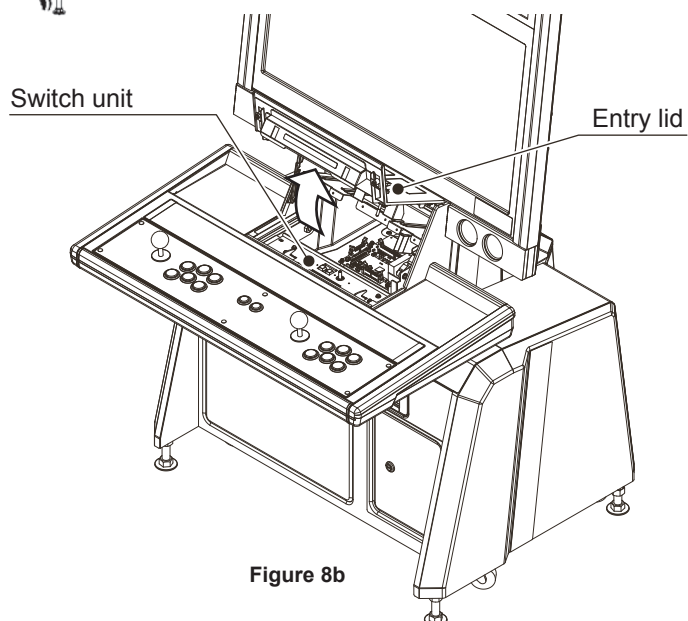
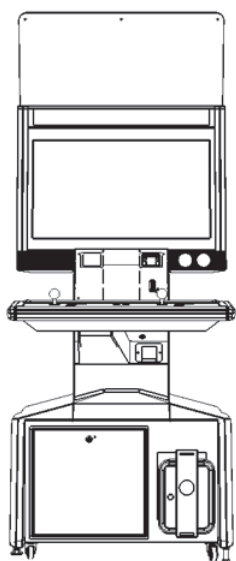

Figure 8b

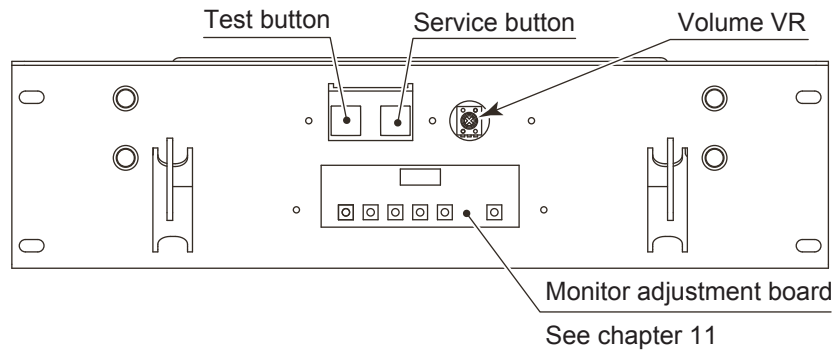
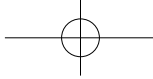

Figure 8c

- Test button : This puts the game board into test mode.
- Service button : This is the service credit button. The coin meter does not count up.
- Volume VR : This adjusts speaker volume.

There is a coin meter inside the cash box door.



IMPORTANT

The game cannot be played if the coin meter circuit is disconnected.

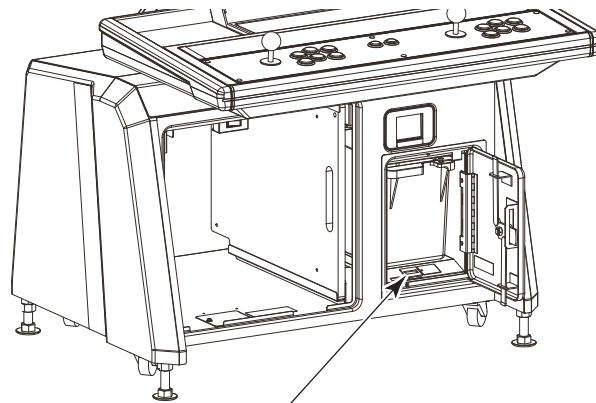

Coin meter
Counts the number of coins inserted

Figure 8d

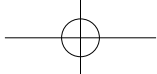

9 For mounting the control panel

WARNING

- Always turn the power switch off before working on the machine. Electric shocks or short-circuit accidents could result.
- Take care not to damage the wiring. Electric shocks or short-circuit accidents could result from damaged wiring.

WARNING

- Take care to avoid trapping your fingers when opening and closing the control box upper cover.
- The control box upper cover can close unexpectedly under its own weight, potentially trapping fingers. Support it securely in place when working with it open.
- If you remove the bolts and nuts fastening the control panel in place, it will fall, causing an accident. Support the control panel securely in place when removing it.

9-1 Replacing the control panel

1 Use the main switch of the AC unit or the sub-power switch behind the service door to turn the power supply off.

2 Unlock the lock on the back of the control box, then open the entry lid.

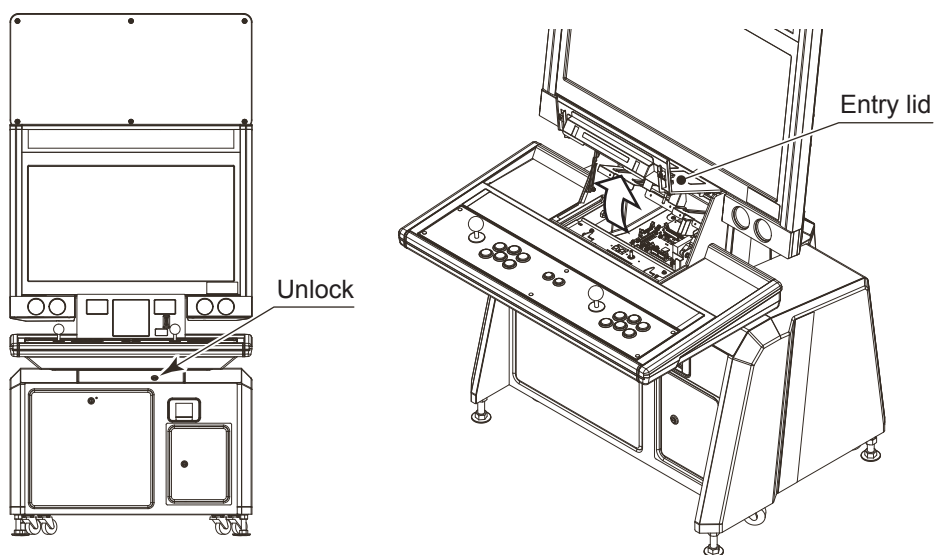
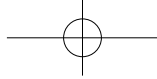

Figure 9.1a



3 Press the tabs together and open the control box upper cover.

* The control box upper cover can close unexpectedly under its own weight, potentially trapping fingers. Secure the control box upper cover in the raised position before proceeding with the operation described below.

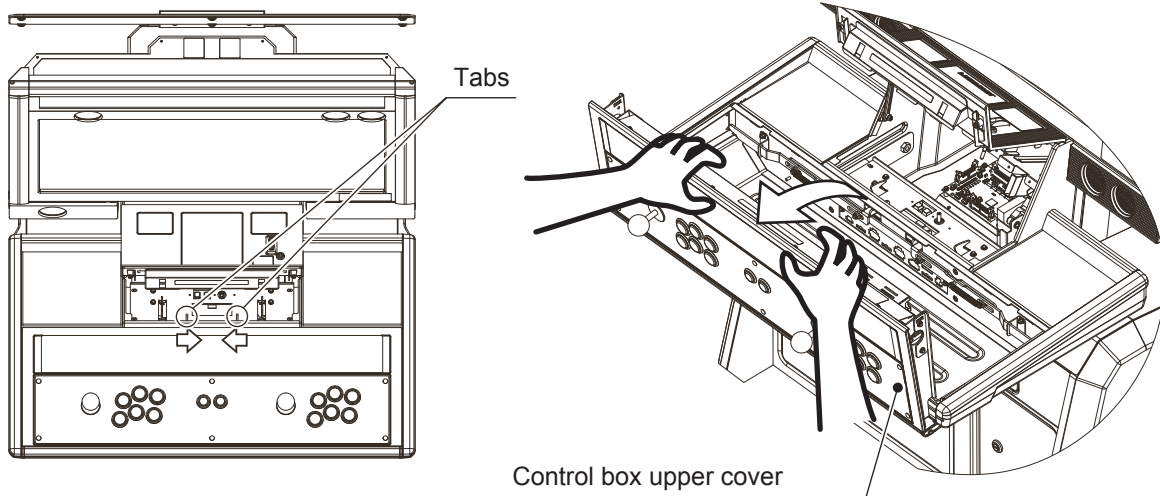

Figure 9.1b

4 There are nine connectors on the connector panel inside the control box. Disconnect all nine connectors. In some cases, some of the connectors may already be disconnected, depending on the game used.

5 Remove six pairs of carriage bolts and flange nuts, then remove the control panel. Take care not to damage the wiring at this stage.

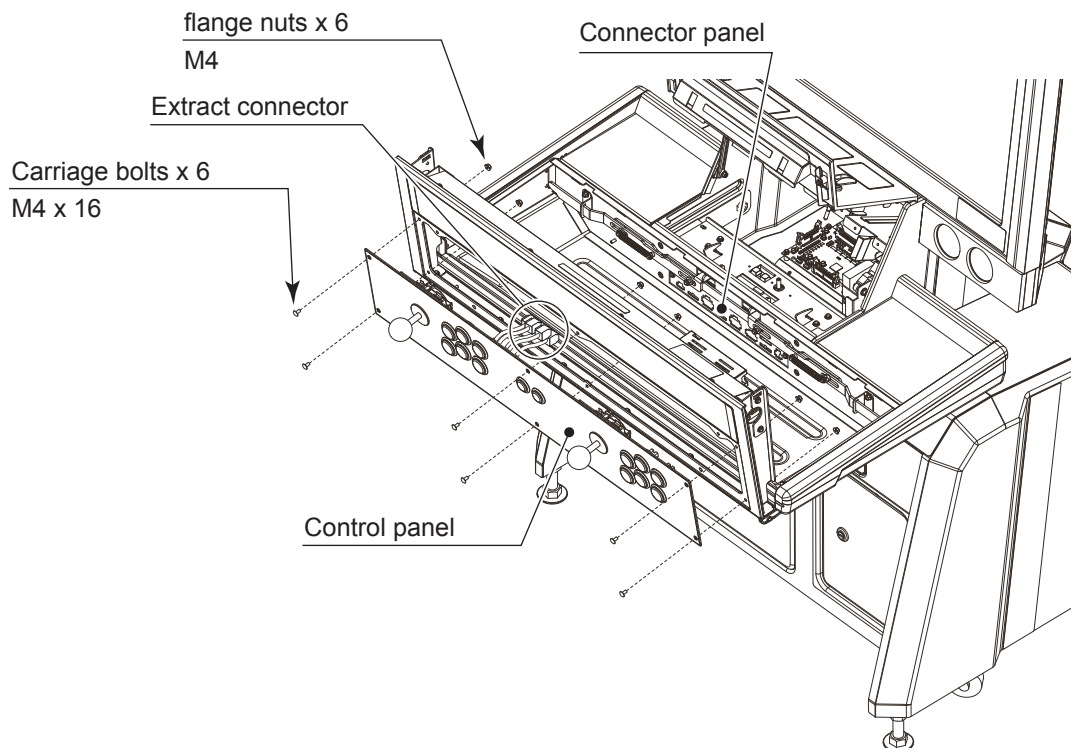
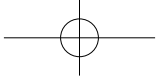

Figure 9.1c

9 For mounting the control panel



Switch caps

When converting to a game with fewer control buttons, remove the buttons from the control panel and fit switch caps into the empty button holes.

9 For mounting the control panel

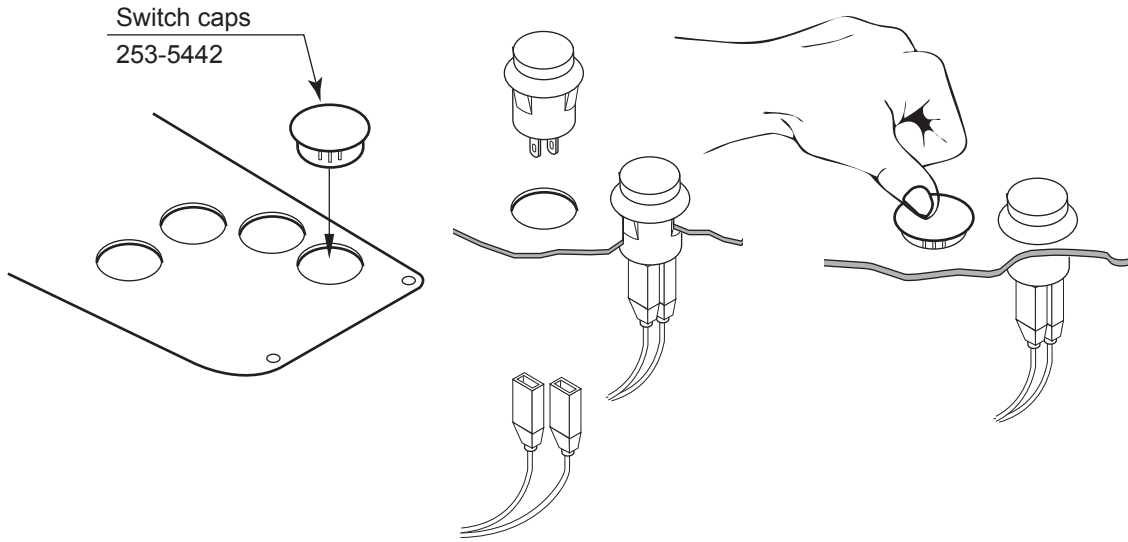
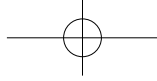

Figure 9.1d



9-2 Replacing the instruction sheet

NOTE

Take care not to hit or apply excessive force to glass components. Careless handling can break glass components, and fragments can cause injury.

- 1** Open the control box upper cover, with reference to steps 1-3 in "9-1".
- 2** Remove the four screws from the back of the control box upper cover, then remove the two brackets, the instruction cover and the instruction sheet. The instruction sheet can be replaced.

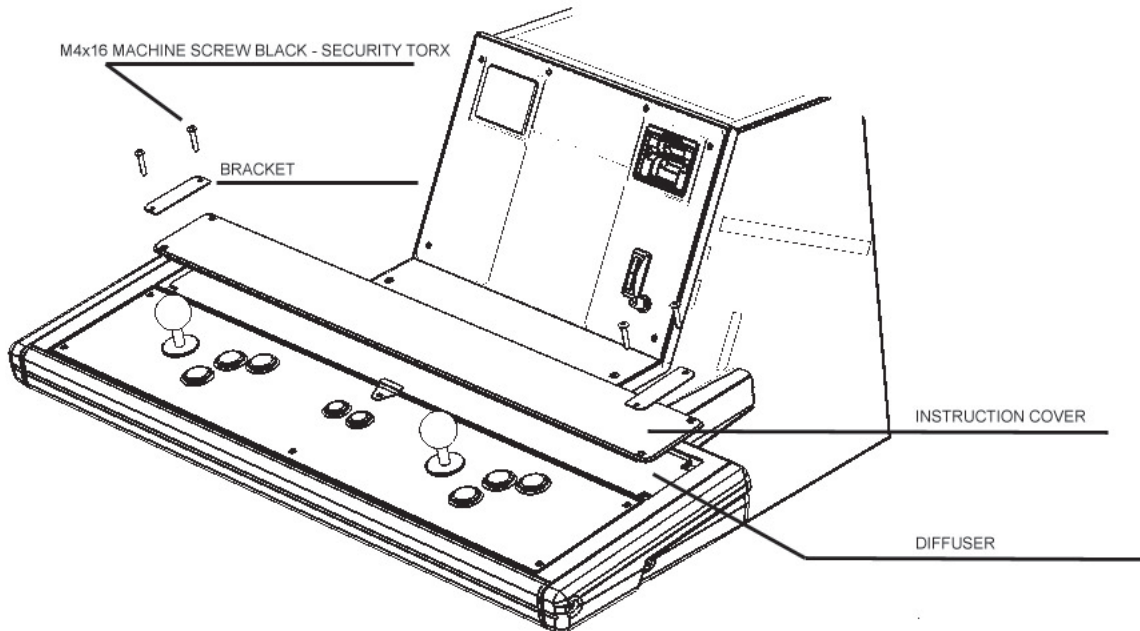

Figure 9.2a

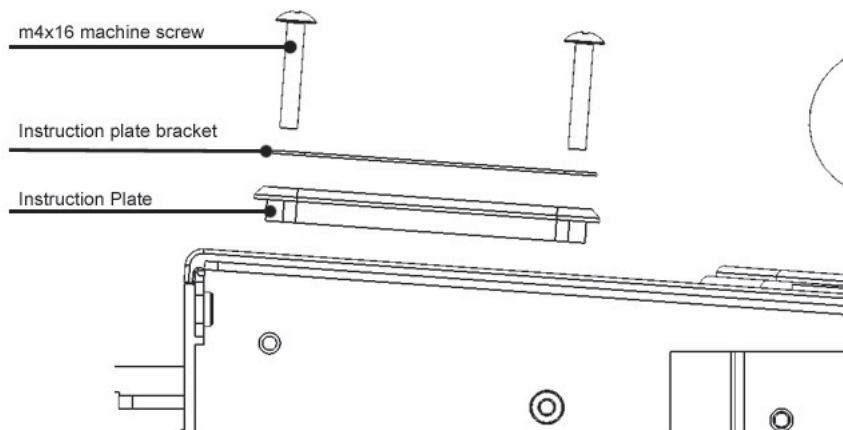
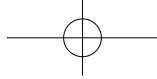

Figure 9.2b



10 Coin selector

WARNING

- Always turn the power switch off before working on the machine. Electric shocks or short-circuit accidents could result.
- Take care not to damage the wiring. Electric shocks or short-circuit accidents could result from damaged wiring.

Removing the coin selector

When the entry lid is open, the coin selector is behind it, on the right side. The selector stopper is behind the selector. Remove it to tilt the selector and pull it out upwards.

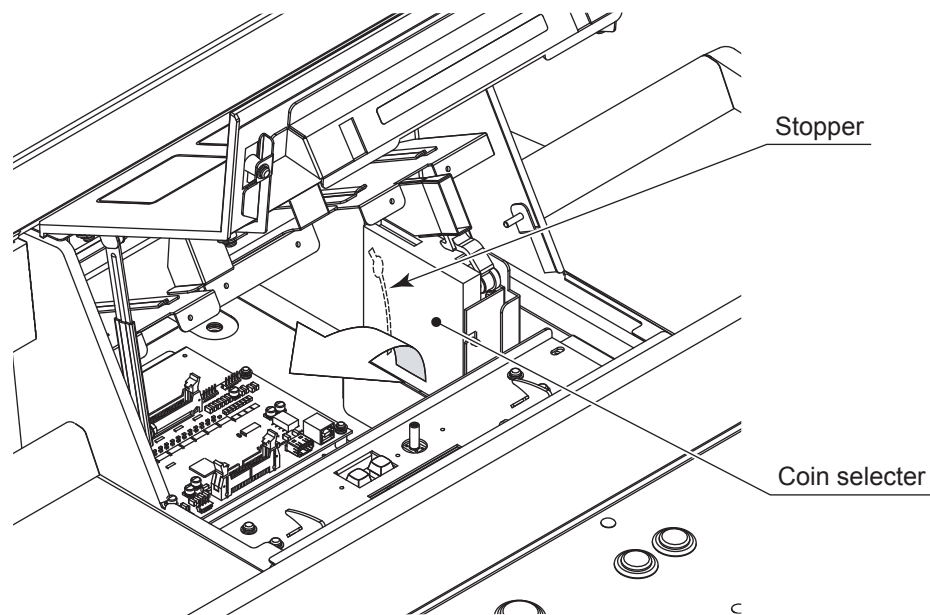
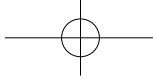

Figure 10a

Repairing coin jams

If pressing the coin return button does not return the coin, open the entry lid and then open the coin selector gate. Remove any jammed coins, then insert a normal coin and check that the selector works normally.



Cleaning the coin selector



- Moisten a soft cloth with water or diluted neutral cleaner, and wring it out firmly before using it for cleaning.
- Never use machine oil etc. on the coin selector.
- After cleaning the coin selector, insert a standard coin under normal usage conditions and check that the selector works normally.

Clean the coin selector every three months. Follow the procedure below to clean it.

- 1 Turn off the game power supply. Open the entry lid.
- 2 Remove the coin selector from inside.
- 3 Open the gate and use a soft brush to brush dirt out.
- 4 Moisten a soft cloth with water or diluted neutral cleaner, and wring it out firmly before using it for wiping.
- 5 Remove the cradle.
When removing the retaining ring (E ring), take care not to bend the shaft.
- 6 Use a soft cloth etc. to wipe dirt off the shaft and bearing.
- 7 After wiping, blow air onto the coin selector to dry it completely.

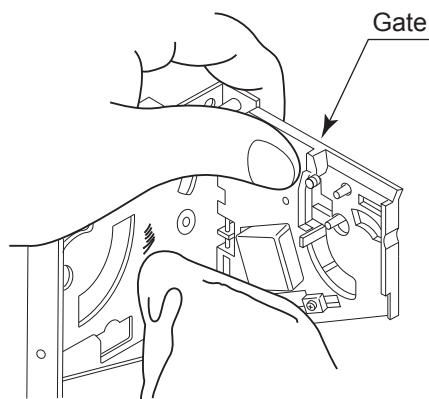

Figure 10b

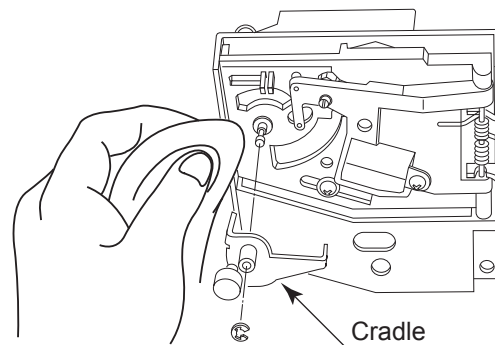
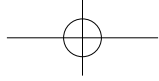

Figure 10b



Coin insertion test

Perform the check below once a month, at the same time as the coin switch test.

- Did the coin meter count the coin normally?
- Did the coin fall into the cash box normally?
- If the coin was inserted with the return button pressed, did it drop out of the coin return slot?

10 Coin selector

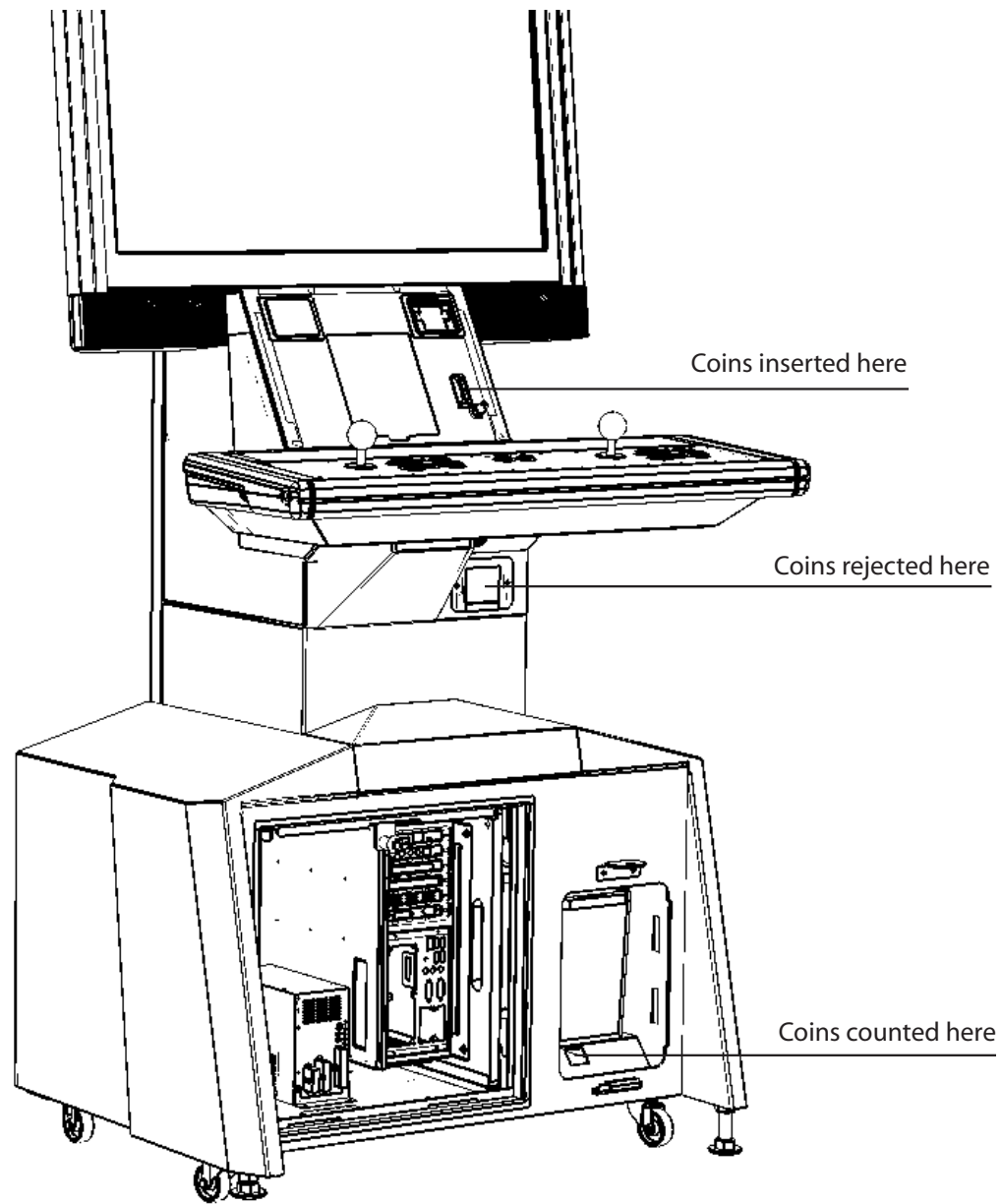

Figure 10d

11 The monitor (LCD display)

11-1 Safety precautions for handling the monitor

WARNING

Handling malfunctions and breakdowns

- If the machine gives off smoke or an unusual odor, unplug it from the socket immediately.
Continued use with a damaged power cable could cause fire or electric shock. Check that no further smoke is given off, then contact the vendor.
- If nothing appears on the screen, unplug the machine from the socket immediately.
Continued use could cause fire or electric shock.
Contact your vendor to arrange an inspection.
- If any liquid or foreign body falls into the interior, unplug the machine from the socket immediately.
Continued use could cause fire or electric shock.
Contact your vendor to arrange an inspection.
- If the machine machine has fallen, or the cabinet has broken, unplug it from the socket immediately.
Continued use could cause fire or electric shock.
Contact your vendor to arrange an inspection.



When using the machine

- Do not attempt to repair, modify or disassemble it.
There are high-voltage components inside which could cause electric shock or fire.
Contact the vendor to arrange internal inspection, adjustment and repair.
- Foreign objects must not enter the machine.
If metal objects, or flammable materials such as paper, drop into the interior through the ventilation holes, they could cause electric shocks.
- Do not touch the body of the machine or its power cable during an electrical storm.
Electric shock accidents could result.
- Be sure to adjust the monitor correctly. Do not operate the monitor with noise or distortion in the image. An incorrectly adjusted screen image can cause dizziness, headache or other symptoms in players or other customers.



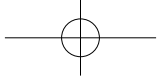

11-2 Cleaning the screen surface

NOTE

- Use a dry, soft cloth to wipe dirt off. Do not use coarse gauze or similar materials.
- Alcohol (ethanol) is suitable as a solvent for wiping. Observe the following restrictions strictly when using detergents.
 - Dilute domestic neutral detergent with water, soak it into a soft cloth, and wring the cloth before using it for wiping.
 - Do not use detergents or powders which contain abrasive particles, detergents containing bleaching agents, or similar cleaners.
 - Never use glass cleaners or other alkaline detergents, or solvents such as thinner.
- Never scrub or scrape the surface with a hard brush or other hard implement.

Clean the screen surface about once a month.

11

The monitor (LCD display)

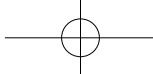

11-3 Monitor adjustment method



The various adjustment values are adjusted accurately in the factory before shipping, so do not change them needlessly, or adjust them other than as specified in this manual. The machine might stop displaying properly.

Operation and adjustment

The basic operation method for using the key switches to make adjustments is explained below. The monitor adjustment board is visible when the entry lid is open. (See Chapter 8)

Names of parts

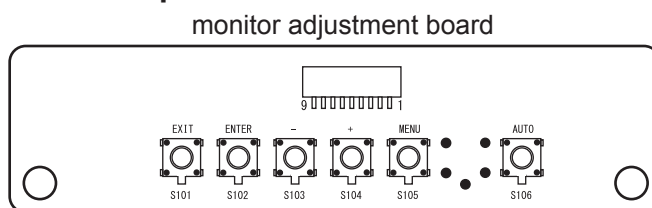

- AUTO : Auto setup (automatic adjustment)
- MENU : Turn on the Menu display and switch between pages.
- + : Shift the selected menu display/ increase adjustment values or setting values.
- : Shift the selected menu display/ decrease adjustment values or setting values.
- ENTER: Set the selected menu display/ save adjustment values or setting values.
- EXIT : Close the menu/ cancel adjustment values or setting values.

- 1** To make adjustments settings, first press "MENU" to display the MENU.
- 2** Next, use the [+] [-] keys to move to the item to adjust/set, then press "ENTER".
- 3** Once the item to adjust/set is displayed at the bottom of the screen, use the [+] [-] keys to adjust/set it.
- 4** Once adjustment/setting is complete, press [ENTER] to store the adjustment/setting values and close.

*To revert to the original values without storing the adjusted/set data, do not press the [ENTER] key, but press the [EXIT] key to return to the MENU screen.

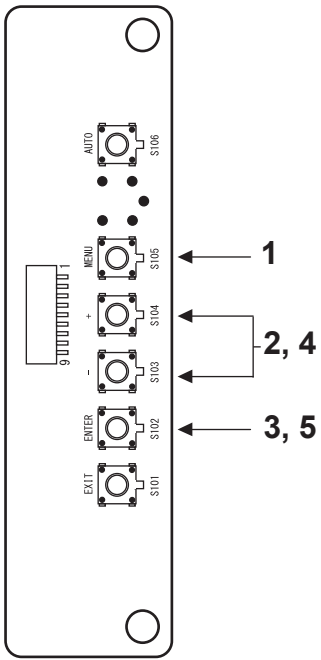

1 Press the [MENU] key.

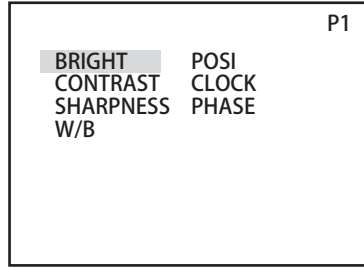

The MENU is displayed.

2 Use the + and - keys to move to each of adjustment and setting items.

3 Use the ENTER key to display each of adjustment and setting items.

4 Use the + and - keys to change each of adjustment and setting items.

5 Use the ENTER key to store each of adjustment and setting items.

The menu

Care is required, because incorrect operation can change the setup state and prevent correct display.

MENU screen

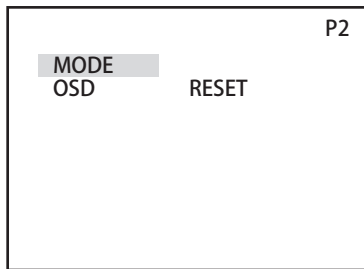
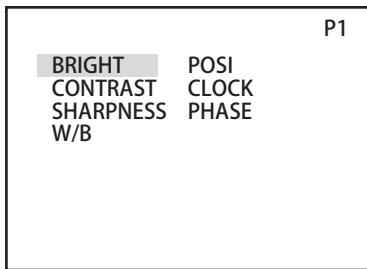

TIMING GAME

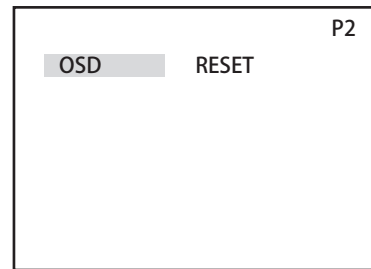

TIMING GAME

When input (640x400) (1360x768)

*Pressing the MENU key changes the page.

List of setting items

		Adjustment / setting value	
		value	value
(P 1)	MENU	BRIGHT.....	-10~ +10
		CONTRAST.....	-10~ +10
		SHARPNESS.....	-10~ +10
		W/B (A/B)	
		R-DRIVE.....	-50~ +50
		G-DRIVE.....	-50~ +50
		B-DRIVE.....	-50~ +50
		R-CUTOFF.....	-50~ +50
		G-CUTOFF.....	-50~ +50
		B-CUTOFF.....	-50~ +50
		POS I	
	H.POS I.....	-64~ +64	
	V.POS I.....	-32~ +32	
	CLOCK.....	-32~ +32	
	PHASE.....	-32~ +32	

(P 2)		MODE.....	WIDE/NORMAL
		OSD.....	ON/OFF
		WIDE/MAC.....	ON/OFF
		RESET.....	-

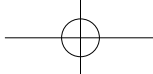

Black level adjustment (BRIGHT)

Black level adjustment (BRIGHT) is performed in the factory to a standard condition, but it can be adjusted for preference. Changing the brightness of the screen changes the prominence of black areas of the screen. However, incorrect adjustment of the black level dramatically reduces screen image quality, so the user is advised to keep the standard settings.

11

The monitor (LCD display)

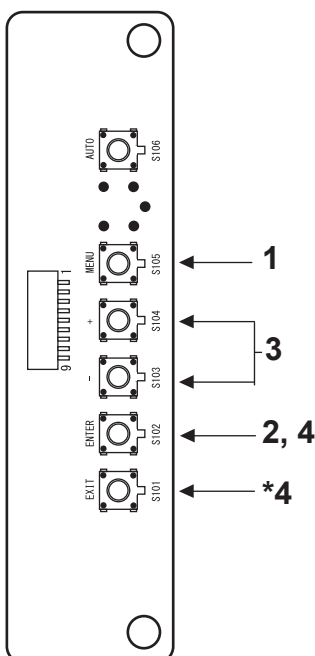

1 Press the [MENU] key.

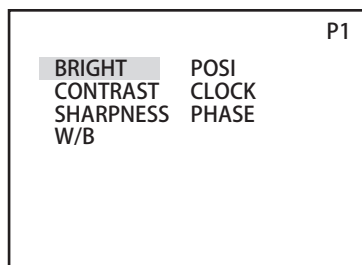

The MENU screen is displayed.

2 The cursor is at the [BRIGHT] position, so press the [ENTER] key to display the adjustment and setting item menu.

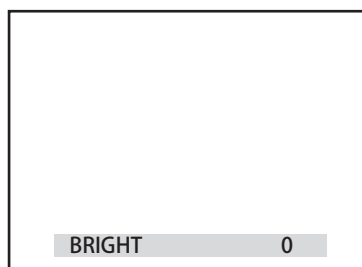

The adjustment and setting item menu is displayed.

3 Use the [+] and [-] keys to adjust.

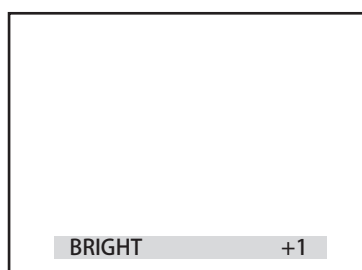

Adjusted data values change. Adjust the screen contrast (CONTRAST) to the desired state.

4 Press the [ENTER] key. (Store and close)

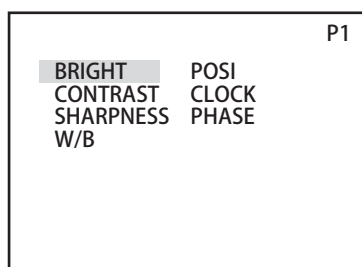

The adjusted data is stored and the display returns to the Menu screen.

*If there is no need to store, press the [EXIT] key to return to the Menu screen without storing.

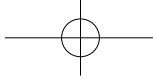

Contrast adjustment (CONTRAST)

Screen contrast (CONTRAST) is performed in the factory to a standard condition, but it can be adjusted for preference. Changing contrast alters the level of shading (contrast) in the screen image.

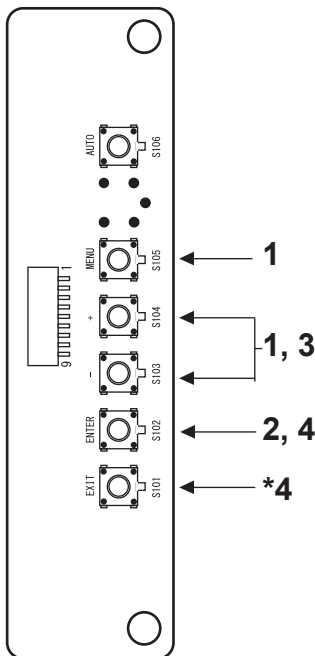

- 1** Press the [MENU] key, then use the [-] key to move the cursor.

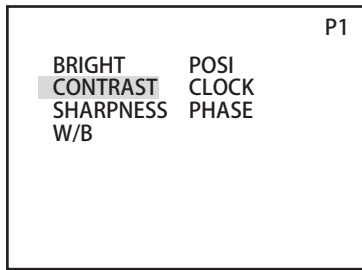

The MENU screen is displayed.

- 2** Move to the CONTRAST position and press the [ENTER] key. The adjustment and setting items are displayed.

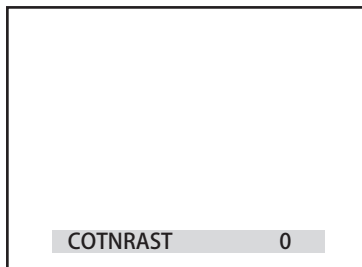

The adjustment and setting item menu is displayed.

- 3** Use the [+] and [-] keys to adjust.

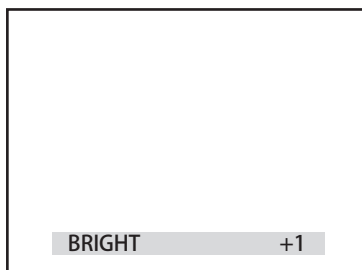

Adjusted data values change. Adjust the screen contrast (CONTRAST) to the desired state.

- 4** Press the [ENTER] key. (Store and close)

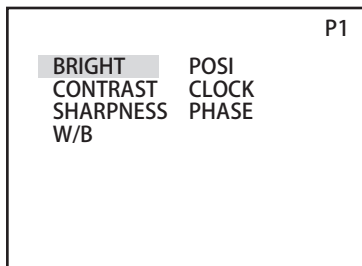

The adjusted data is stored and the display returns to the Menu screen.

*If there is no need to store, press the [EXIT] key to return to the Menu screen without storing.

Sharpness adjustment (SHARPNESS)

Screen contrast (CONTRAST) is performed in the factory to a standard condition, but it can be adjusted for preference. Adjusting sharpness alters the level of emphasis on boundaries in the image.

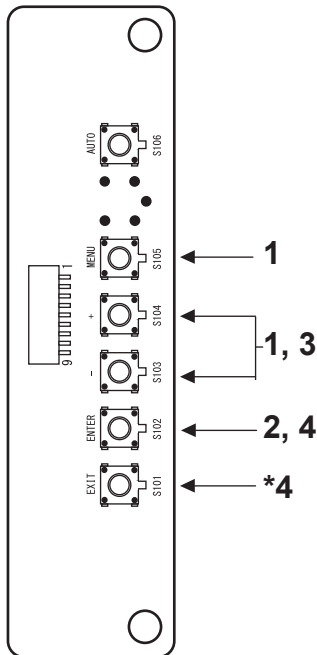

1 Press the [MENU] key, then use the [-] key to move the cursor.

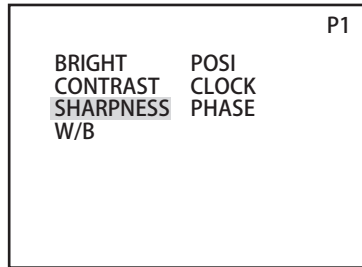

The MENU screen is displayed.

2 Move to the SHARPNESS position and press the [ENTER] key.

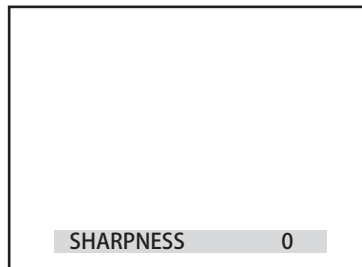

The adjustment and setting items are displayed.

3 Use the [+] and [-] keys to adjust.

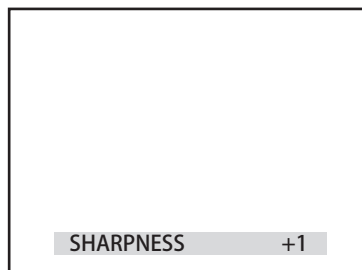

Adjusted data values change. Adjust the screen SHARPNESS to the desired state.

4 Press the [ENTER] key. (Store and close)

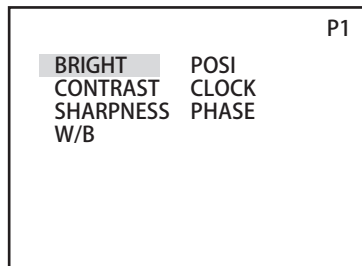

The adjusted data is stored and the display returns to the Menu screen.

*If there is no need to store, press the [EXIT] key to return to the Menu screen without storing.

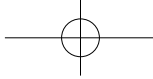

White balance adjustment (W/B)

Screen white balance (W/B) is performed in the factory to a standard condition, but it can be adjusted for preference. However, incorrect adjustment of the white balance dramatically reduces screen image quality, so the user is advised to keep the standard settings.

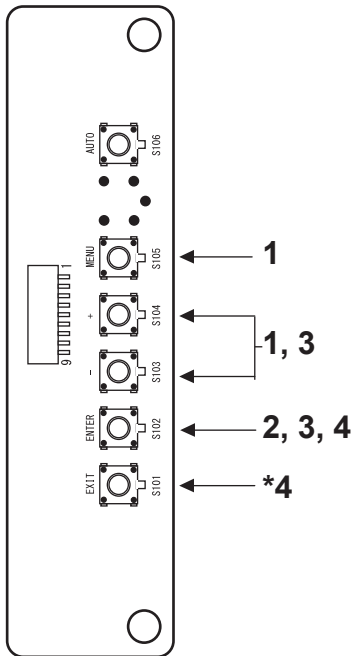

- 1** Press the [MENU] key, then use the [-] key to move the cursor.

P1	
BRIGHT	POSI
CONTRAST	CLOCK
SHARPNESS	PHASE
W/B	

The MENU screen is displayed.

- 2** Move to the W/B position and press the [ENTER] key. The adjustment and setting items are displayed.

W/B	
R-DRIVE	0
G-DRIVE	0
B-DRIVE	0
R-CUTOFF	0
G-CUTOFF	0
B-CUTOFF	0

The adjustment and setting item menu is displayed.

- 3** Select the item to adjust and press the [ENTER] key, then adjust with the [+] and [-] keys.

R-DRIVE	+1
---------	----

Adjusted data values change. Adjust the screen white balance (W/B) to the desired state.

- 4** Press the [ENTER] key. (Store and close)

W/B	
R-DRIVE	0
G-DRIVE	0
B-DRIVE	0
R-CUTOFF	0
G-CUTOFF	0
B-CUTOFF	0

The adjusted data is stored and the display returns to the Menu screen.

*If there is no need to store, press the [EXIT] key to return to the Menu screen without storing.

Adjustment of screen display image (POSI)

Screen display position (POSI) is adjusted in the factory to a standard condition, but it can be adjusted for preference. In some cases, it may be necessary to make adjustments after changing game software.

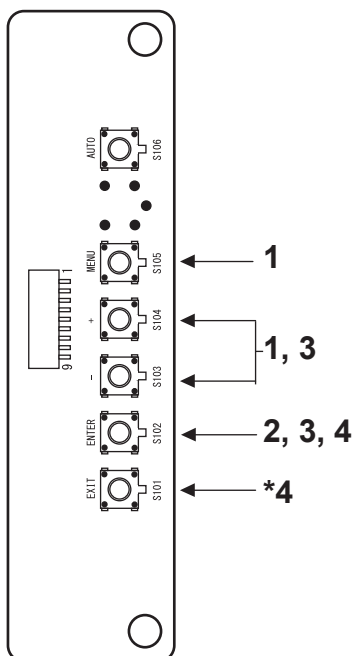

- 1** Press the [MENU] key, then use the [+] key to move the cursor.

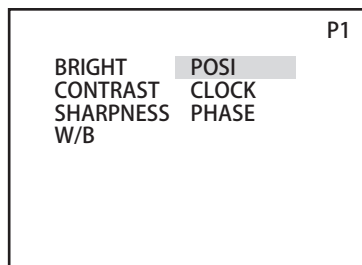

The MENU screen is displayed.

- 2** Move to the POSI position and press the [ENTER] key. The adjustment and setting items are displayed.

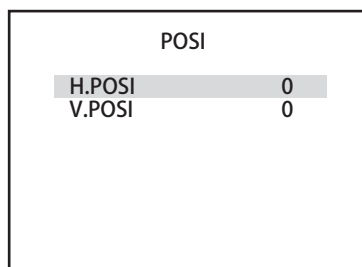

The adjustment and setting item menu is displayed.

- 3** Select the item to adjust and press the [ENTER] key, then adjust with the [+] and [-] keys.

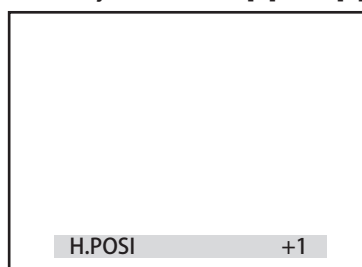

Adjusted data values change. Adjust the screen position (POSI) to the desired state.

- 4** Press the [ENTER] key. (Store and close)

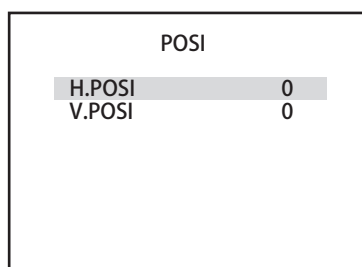

The adjusted data is stored and the display returns to the Menu screen.

*If there is no need to store, press the [EXIT] key to return to the Menu screen without storing.

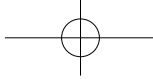

Clock adjustment (CLOCK)

The screen sampling clock (CLOCK) is adjusted in the factory to a standard condition, but it can be adjusted for preference. In some cases, it may be necessary to make adjustments after changing game software.

However, incorrect clock adjustment dramatically reduces screen image quality, causing jittering and moire patterns, so the user is advised to keep the standard settings.

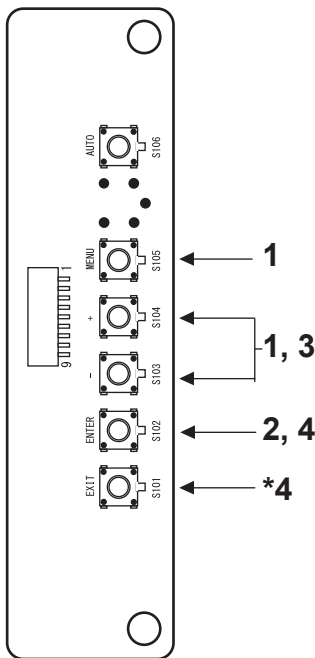

- 1** Press the [MENU] key, then use the [-] key to move the cursor.

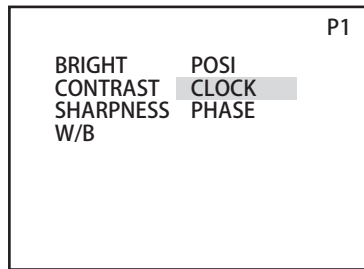

The MENU screen is displayed.

- 2** Move to the CLOCK position and press the [ENTER] key. The adjustment and setting items are displayed.

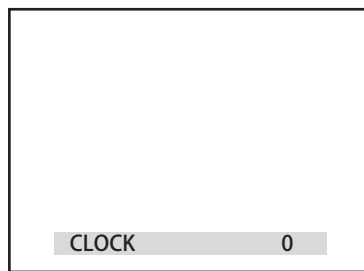

The adjustment and setting item menu is displayed.

- 3** Use the [+] and [-] keys to adjust.

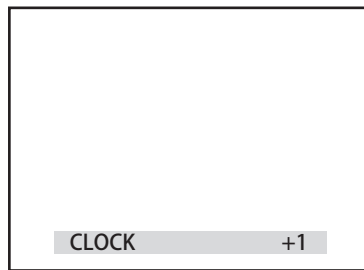

Adjusted data values change. Adjust so that the sampling clock is in the optimum state. (so that jitter and moire effects disappear)

- 4** Press the [ENTER] key. (Store and close)

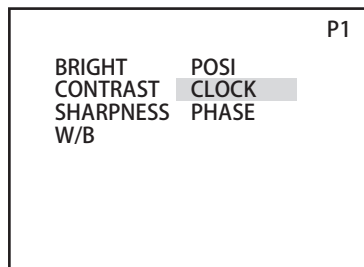

The adjusted data is stored and the display returns to the Menu screen.

*If there is no need to store, press the [EXIT] key to return to the Menu screen without storing.

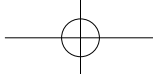

Phase adjustment (PHASE)

The screen sampling phase (PHASE) is adjusted in the factory to a standard condition, but it can be adjusted for preference. In some cases, it may be necessary to make adjustments after changing game software.

However, incorrect phase adjustment dramatically reduces screen image quality, causing jittering, so the user is advised to keep the standard settings.

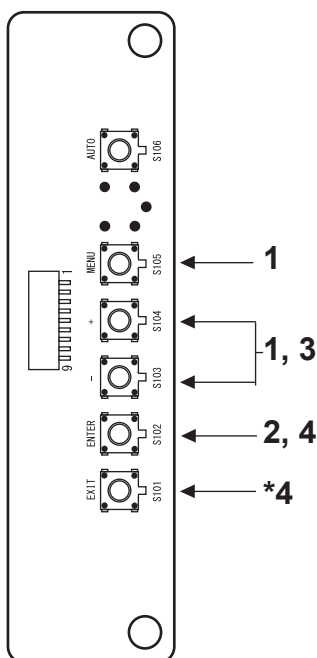

1 Press the [MENU] key, then use the [-] key to move the cursor.

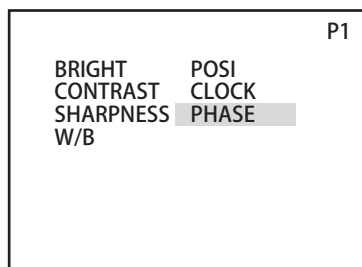

The MENU screen is displayed.

2 Move to the PHASE position and press the [ENTER] key. The adjustment and setting items are displayed.

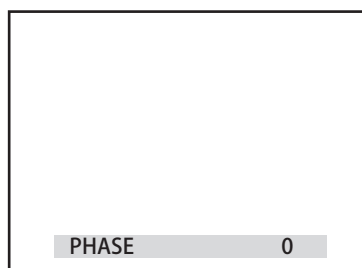

The adjustment and setting item menu is displayed.

3 Use the [+] and [-] keys to adjust.

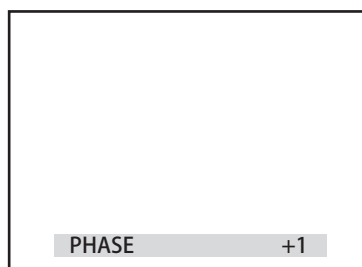

Adjusted data values change. Adjust so that the sampling phase is in the optimum state. (Jitter disappears)

4 Press the [ENTER] key. (Store and close)

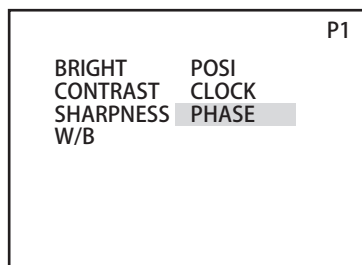

The adjusted data is stored and the display returns to the Menu screen.

*If there is no need to store, press the [EXIT] key to return to the Menu screen without storing.

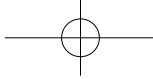

Aspect ratio switching (MODE)

The aspect ratio of the screen can be switched. When WIDE is used, the display fills the entire screen, but when NORMAL is used, the screen display is the maximum size possible at the aspect ratio of the input signal. However, this is not the case when input at 640 x 400, 1,360 x 768 or 1,280 x 720 is used.

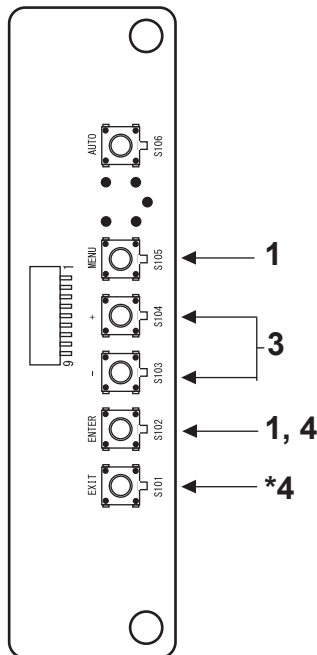

- 1 Press the [MENU] key twice, then press the [ENTER] key at the MODE position.

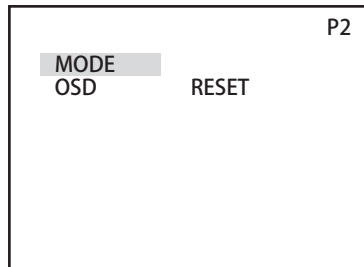

The MENU P2 screen is displayed.

- 2 MODE MENU is displayed.

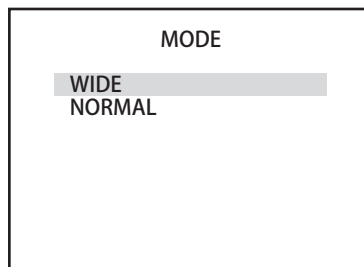

The adjustment and setting item menu is displayed.

- 3 Use the [+] and [-] keys to adjust.

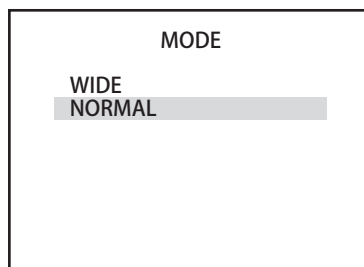

The display screen changes when the setting value changes.

- 4 Press the [ENTER] key. (Store and close)

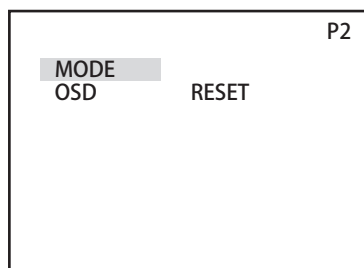

The adjusted data is stored and the display returns to the Menu screen.

*If there is no need to store, press the [EXIT] key to return to the Menu screen without storing.

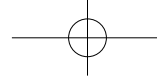

On-screen display (OSD)

ON: Always display the OSD corresponding to (ANALOG/DIGITAL).

OFF: Only display when the above input is changed.

Notes: In case of No Input Signal or Out of Range, the OSD is displayed continuously while the condition persists, regardless of whether the setting is on or off.

Input signal identification (WIDE/MAC)

PCinput.

ON: Only enabled with input is VGA-TEXT (720x400)/MAC13/MAC16/MAC19/MAC21/WVGA/WSVGA/WXGA/720p.

OFF: Identification of WID/MAC-type signals is OFF

Reset (RESET)

Adjust setting values for BRIGHT, CONTRAST, W/B, SHARPNESS, POSI, CLOCK, PHASE, MODE, OSD and WIDE/MAC/to the factory defaults.

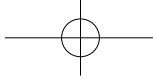

Auto setup

When auto setup is performed, signal timing is identified automatically, and the items below are automatically adjusted to their optimum values/stored.

- Sampling frequency/phase
- Horizontal/vertical display position

Memory can hold up to 136 settings in the user area, so once the number of settings exceeds 136, they will be overwritten sequentially.

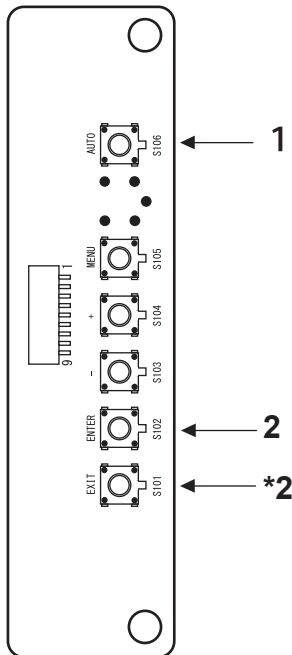

1 Press the [AUTO] key.

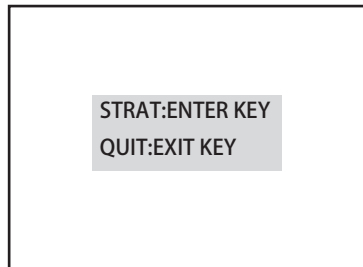

The setting screen is displayed.

2 Press the [ENTER] key.

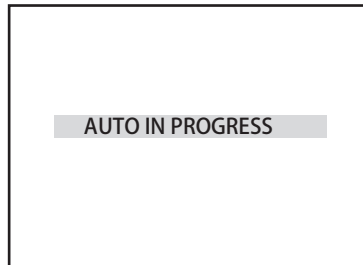

Auto setup is performed.

*Press the [EXIT] key to avoid executing.

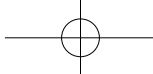

Input signal

No.	Input signal name	Horizontal frequency [kHz]	Vertical frequency [Hz]
1	(640x400)	31.46	70.07
2	(640x480):VESA	31.38	59.77
3	(640x480):NAOMI	31.69	59.79
4	(640x480):TRIFORCE	31.47	59.94
5	(640x480):CHIHIO	31.47	59.94
6	(800x480)	29.77	59.54
7	(800x600)	37.95	60.43
8	(1024x600)	37.51	60.12
9	(1024x768)	48.34	59.97
10	(1280x768)	47.92	60.05
11	(1280x1024)	63.98	60.02
12	(1360x768)	47.51	59.53

11 The monitor (LCD display)

12 Replacing the fluorescent lamp

WARNING

- Always turn the power off before working on the machine. Working with the power switched on could lead to electric shocks or short-circuit accidents.
- Touching a hot fluorescent tube could cause a burn. Take care when replacing the tube.

1 Use the main switch of the AC unit or the sub-power switch behind the service door to turn the power supply off.

2 Remove the two truss screws and lift the billboard assembly up to remove it.

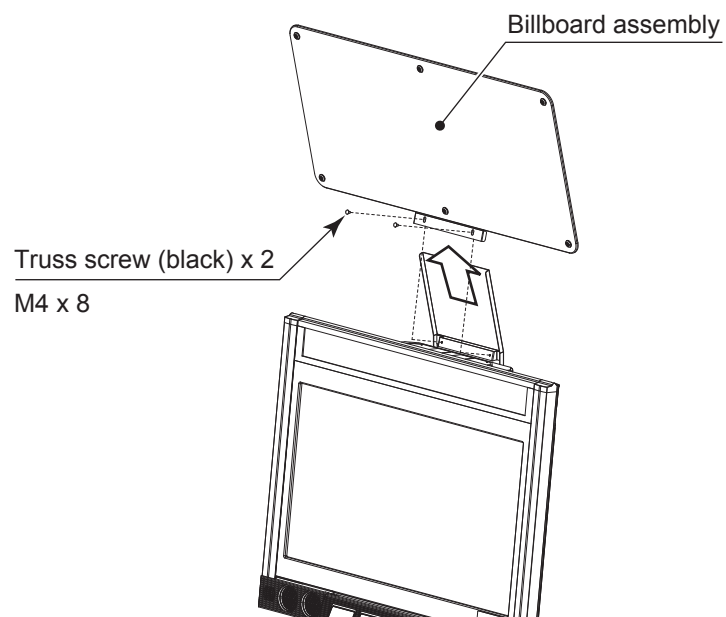
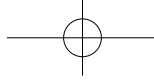

Figure 12a



3 Remove the 6 screws and the light box lid assembly to replace the fluorescent lamp.

12 Replacing the fluorescent lamp

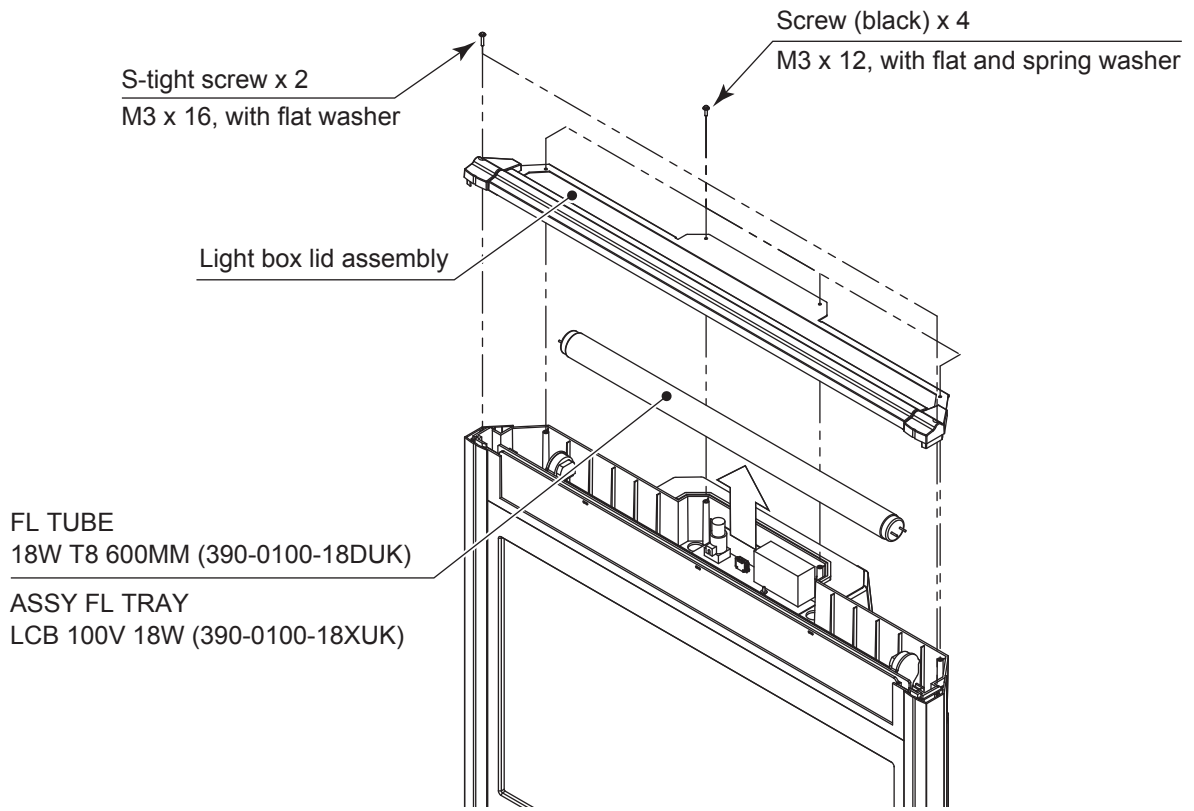
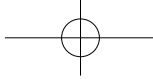

Figure 12b



13 Replacing the game board

WARNING

- Be sure to turn the power off before touching the inside of the machine, to prevent electric shock accidents.
- Take care not to damage the wiring. Electric shocks or short-circuit accidents could result from damaged wiring.
- The current capacities for game boards in this product are 3.3V 12A, 5.0V 10A, 12V 2A. Never use game boards which require capacity above these values. Use of such boards would cause overheating and ignition.
- When changing to a game board that does not follow the JAMMA standard, be sure to use the dedicated harness specified by the game board manufacturer. Use of anything other than the specific dedicated wiring risks causing overheating and fire.

This manual explains how to remove the Lindbergh. Before starting work to change to a different game board, contact the game board vendor and check it thoroughly.

13-1 How to remove the game board

To remove the game board (Lindbergh), take the entire base (wooden board), on which the game board is mounted, out of the cabinet.

- 1 Use the main switch of the AC unit or the sub-power switch behind the service door to turn the power supply off. Loosen the anti-unlocking screw to unlock the service door.
- 2 Remove all the connectors which are connected to the game board. Also remove all other connectors on the base that connect to anything other than the game board. The number of connectors varies between games.

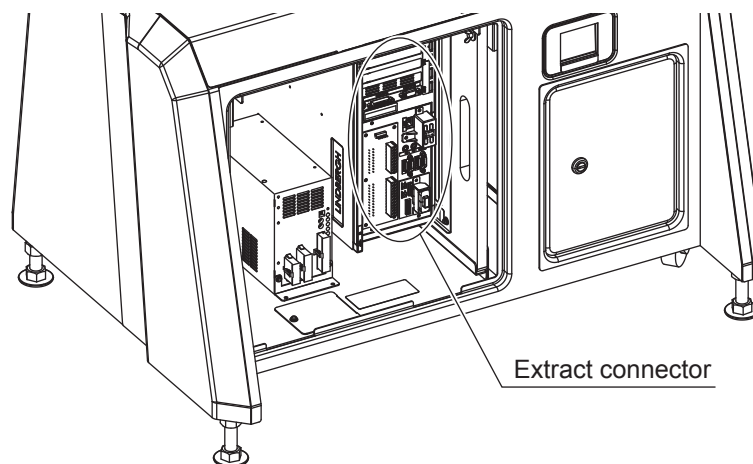
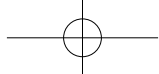
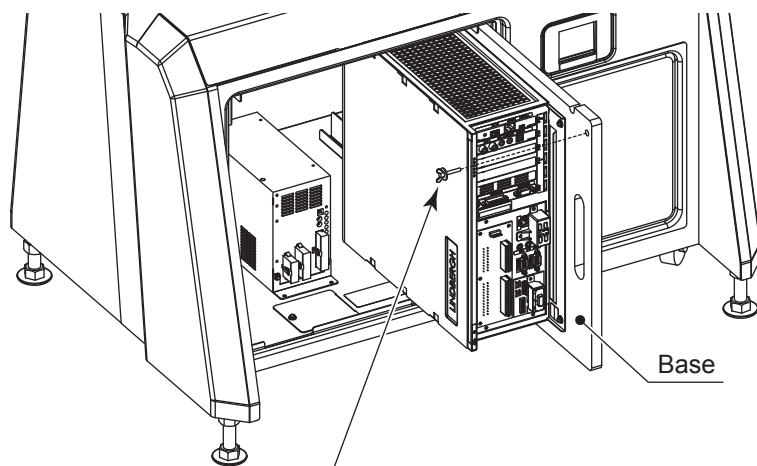

Figure 13.1a



- 3 Remove the one thumb screw that fastens the base, then remove it from the cabinet, with the game board still attached.



Thumb screw x 1
M4 x 25, using flat and spring washer

Figure 13.1b

- 4 Remove the four screws and take the game board off.

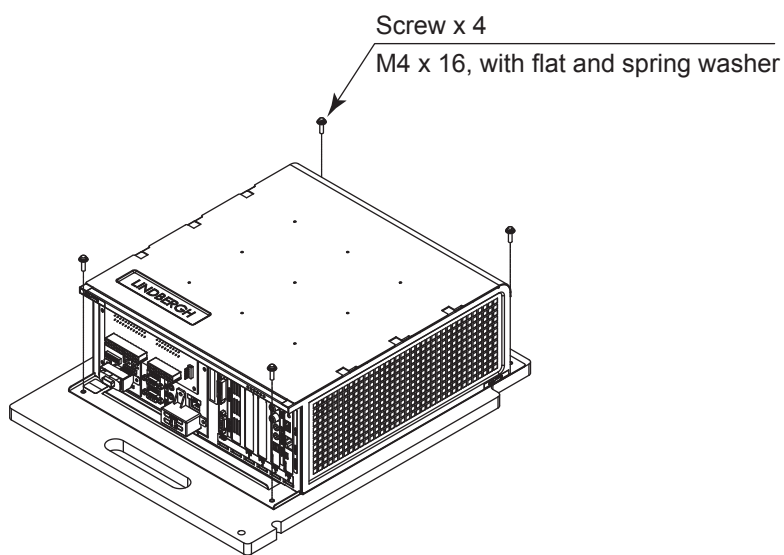
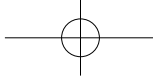

Figure 13.1c



13-2 Replacing the design components

Replacement may be required for some game titles.
Basically, replace the billboard sheet, the instruction sheet and the sub-instruction sheet.
Refer to "9-2" for replacement of the instruction sheet.

Replacing the billboard sheet

- 1 Remove the two truss screws and lift the billboard assembly up to remove it.

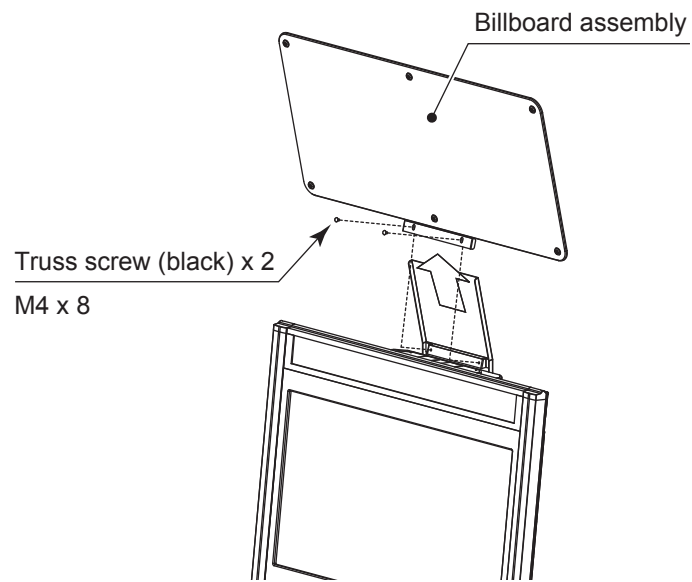

Figure 13.2a

- 2 Remove the six Allen screws and the billboard front plate to replace the billboard sheet.

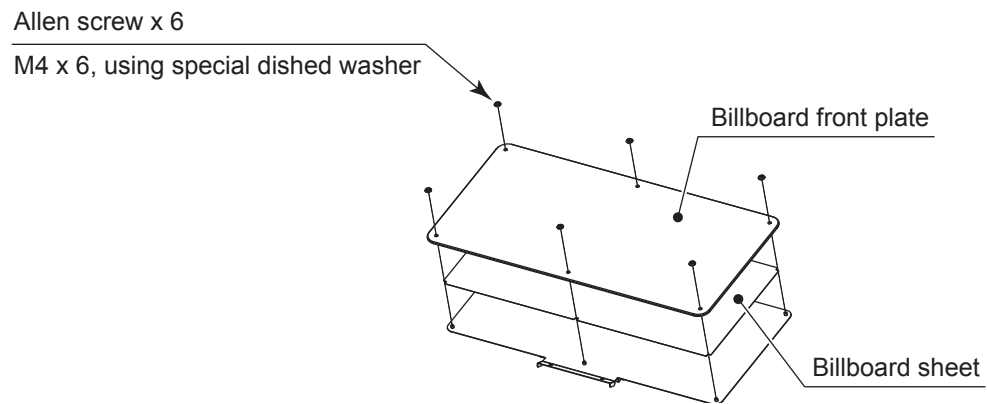
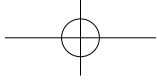

Figure 13.2b



Sub-instruction sheet

Affix the sub-instruction sheet to the entry lid.

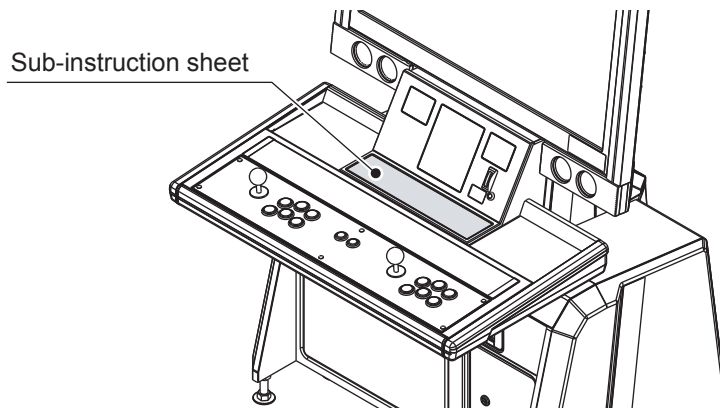

Figure 13.2c

13

Replacing the game board

13-3 The game board power supply voltage adjustment knob

STOP
IMPORTANT

V.ADJ has already been set at the factory. Use it with the factory default setting. Needless alteration of the setting can damage the IC board and cause malfunctions.

The power supply unit inside the cabinet has a VR for adjusting game board DC power supply voltage.

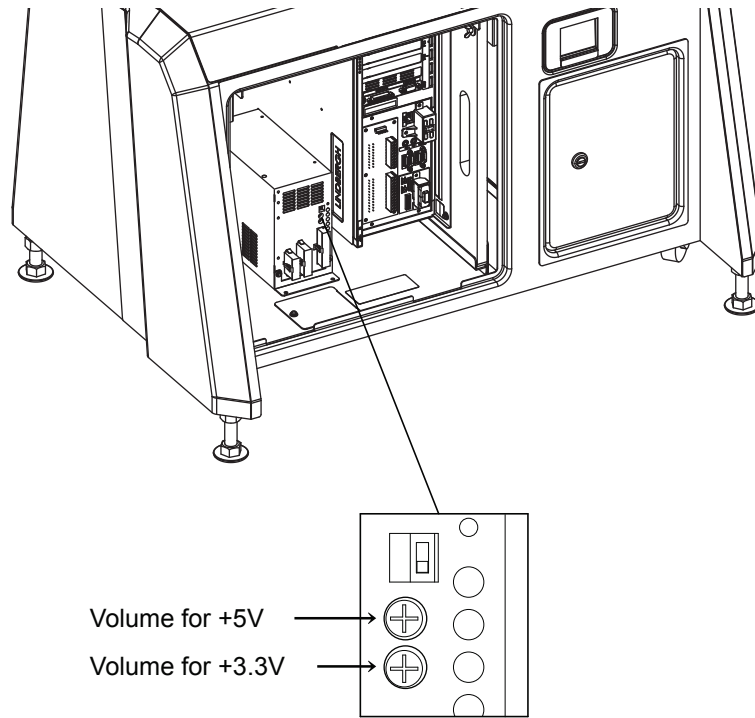
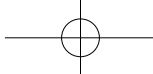

Figure 13.3 Power supply unit



14 Regular inspection list

Perform regular inspection and maintenance of the items below, to maintain the performance of the machine and ensure the safety of its operation.

The control panel is touched directly by the player's hands. Clean it as often as necessary, and provide hand wipes etc. so players can play without worrying about cleanliness.

14

Regular inspection list

WARNING

- **Once a year, check that the power cable is undamaged, that the plug is securely inserted into the socket, and that there is no buildup of dust between the socket and the plug. Use with a buildup of dust could cause accidents or damage.**
- **Once a year, contact the vendor or the service contact named in this manual to order cleaning of the interior of the machine. Leaving dust to accumulate inside the machine without cleaning can cause fire or other accidents. A fee will be charged for interior cleaning.**

Table 14 Regular inspection list

	Task	Interval	Reference item
Cabinet	Check that all adjusters touch the ground	Daily	Ch. 3
Monitor (LCD display)	Clean the screen surface	Weekly	11-2
	Check adjustment	Monthly	See the game board servicing manual
Game board	Check settings	Monthly	
Control panel	Input test	Monthly	
Speakers and sound	Sound test, volume adjustment check	Monthly	
The coin selector	Coin insertion test	Monthly	Ch. 10
	Cleaning	Every 3 months	
Power plug	Inspection, cleaning	Yearly	As above
Internal	Cleaning		
Cabinet surfaces	Cleaning	As required	As below

Cleaning cabinet surfaces

If the cabinet is very dirty, wet a soft cloth with water, or with diluted neutral detergent, wring it out and use it to wipe the cabinet. Do not use solvents such as alcohol, thinner or benzene, or abrasives, bleaches or chemical cloths, because they may damage the surface finish. Some general home, kitchen or furniture detergents are strong enough to penetrate plastic components, paints and printing. Before using any detergent, read the precautions carefully, and test its effects first on an inconspicuous area.

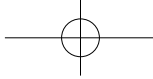

15 Parts list

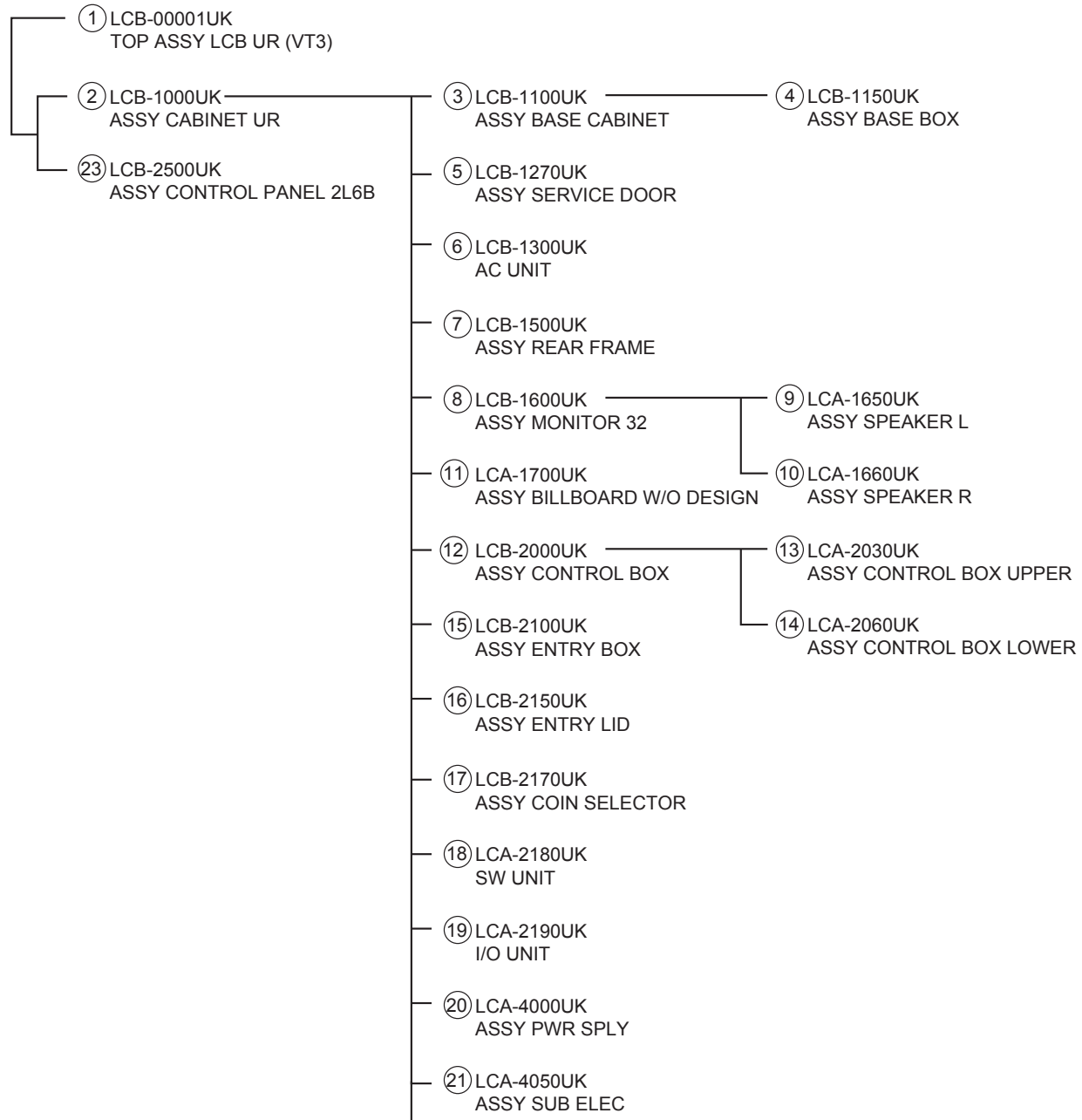

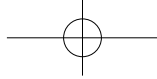

1 TOP ASSY LCB UR (VT3) (LCB-00001UK)

(D-1/2)

15 Parts list

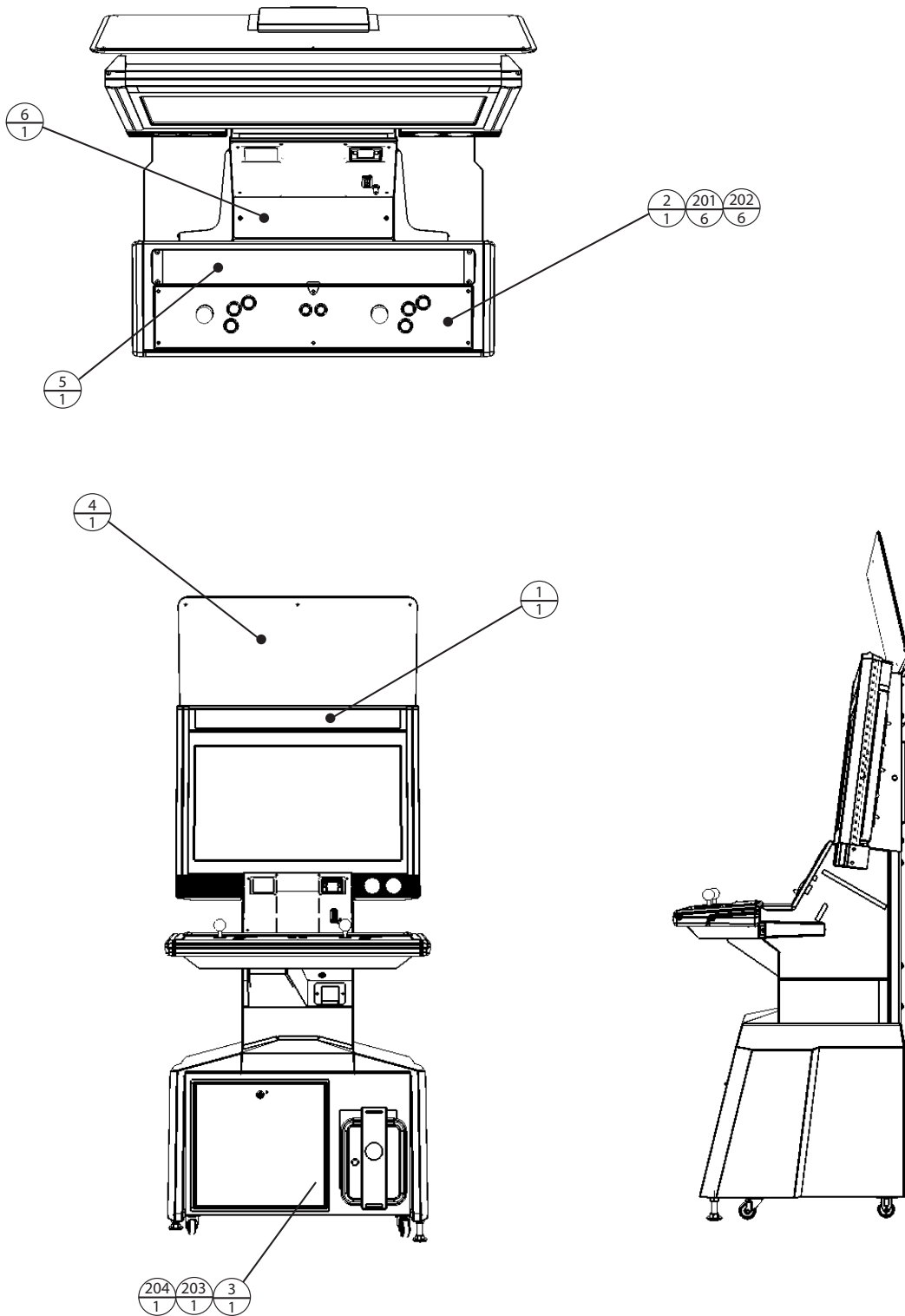

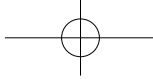

① TOP ASSY LCB UR (VT3) (LCB-00001UK)

(D-2/2)

ITEM NO.	PART NO.	DESCRIPTION	NOTE
1	LCA-1000UK	ASSY CABINET UR	
2	LCA-2500UK	ASSY CONTROL PANEL 2L6B	
3	LCB-0101UK	WOODEN BASE MAIN	
4	429-0777-01UK	BILLBOARD SHEET VT3	
5	422-0946U	SHEET INSTR VT3	
6	LCA-0004	STICKER SUBINSTR LCA	
201	031-0S0416	CRG BLT STN M4×16	
202	050-F00400	FLG NUT M4	
203	032-000425	WING BLT M4×25	
204	068-441616	FLT WSHR 4.4-16×1.6	
205	060-S00400	SPR WSHR M4	
401	253-5442	ANTI BACTERIAL CAP SW	
402	LCA-60027	WH DC PWR SPLY FOR JVS BD	
403	LCA-60028	WH DC PWR SPLY FOR ATX BD	
404	000-P00416-W	M SCR PH W/FS M4×16	

15

Parts list

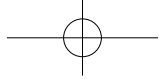

2 ASSY CABINET UR (LCB-1000UK)

(D-1/3)

15 Parts list

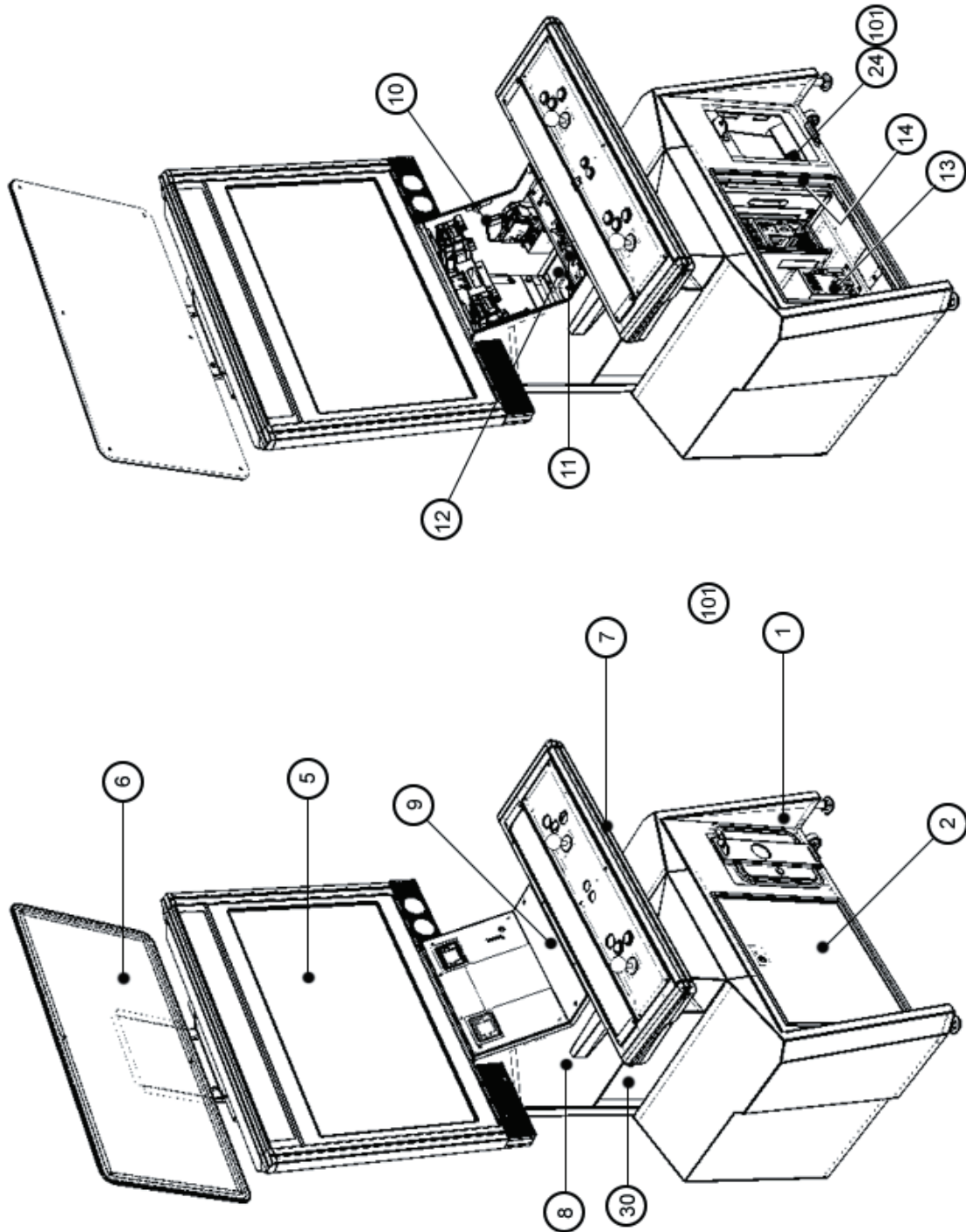

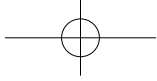

② ASSY CABINET UR (LCB-1000UK)

(D-2/3)

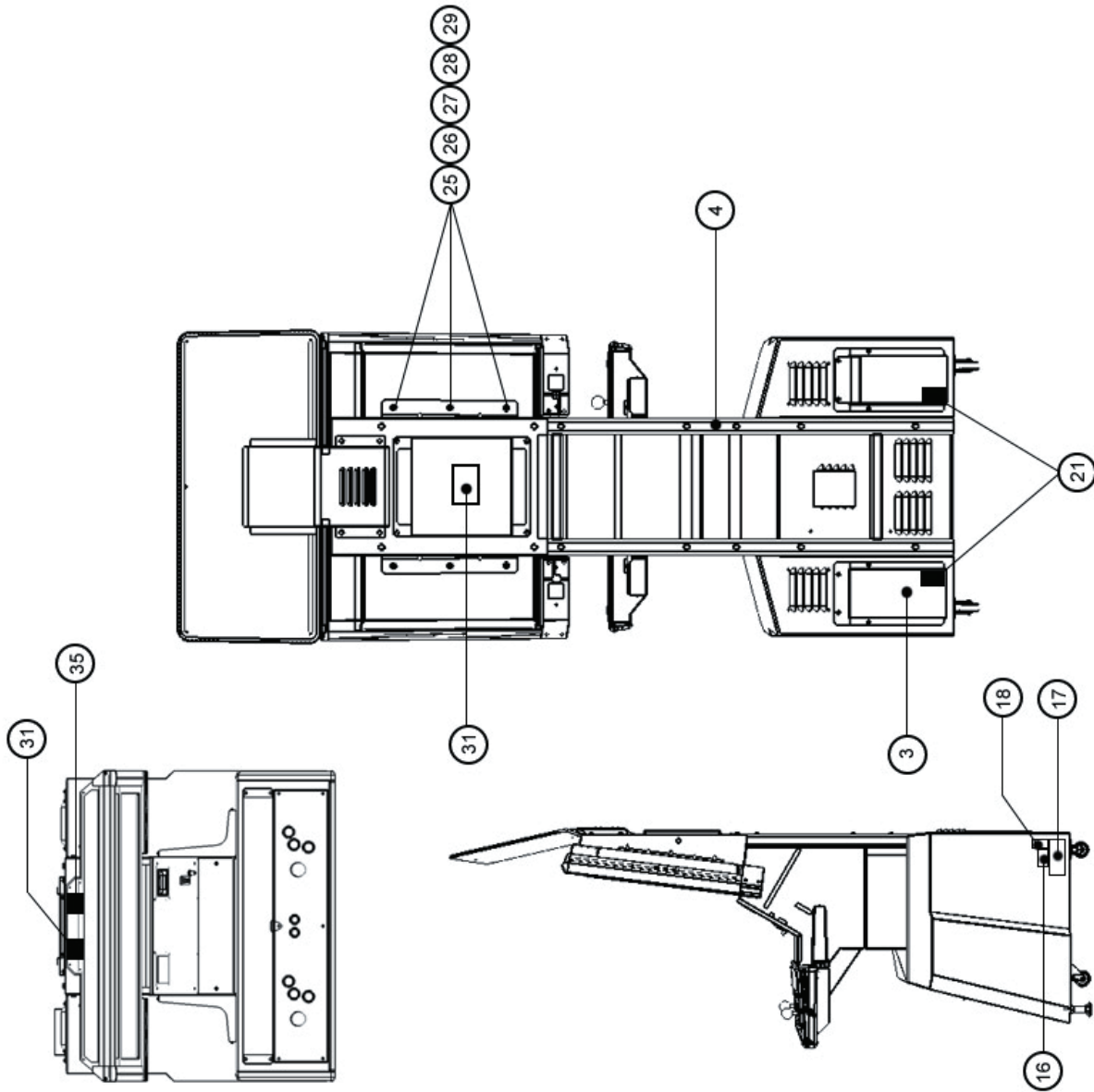

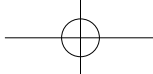

② ASSY CABINET UR (LCB-1000UK)

(D-3/3)

15

Parts list

ITEM NO.	PART NO.	DESCRIPTION	NOTE
1	LCB-1100UK	ASSY BASE CABINET	
2	LCB-1270UK	ASSY SERVICE DOOR	
3	LCB-1300UK	ASSY AC UNIT	
4	LCB-1500UK	ASSY REAR FREAME	
5	LCA-1600UK	ASSY MONITOR 32"	
6	LCA-1700UK	ASSY BILLBOARD W/O DESIGN	
7	LCB-2000UK	ASSY CONTROL BOX	
8	LCB-2100UK	ASSY ENTRY BOX	
9	LCB-2150UK	ASSY ENTRY LID	
10	LCB-2170UK	ASSY COIN SELECTOR	
11	LCA-2180UK	ASSY SWITCH UNIT	
12	LCA-2190UK	ASSY I/O UNIT	
13	LCA-4000UK	ASSY PWR SUPPLY	
14	LCA-4050UK	ASSY SUB ELEC	
16	421-7988-91UK	STICKER SERIAL NUMBER	
17	LB1046	LABEL TESTED FOR ELEC. SAFETY	
18	LB1130	LABEL WEEE WHEELIE BIN	
21	421-7020UK	STICKER CAUTION FORK	
24	421-9168-01	STICKER COIN METER	
25	280-5113	COLLAR FOR NANA0 MONITOR	
26	280-5114	SPACER 6.4-25X2	
27	253-5569	BUSH FOR LCD	
28	253-5570	CAP FOR LCD	
29	123-5123	STUD BOLT M6 FOR LCD	
30	LCB-1050UK	ASSY MID BOX	
31	LB1102	STICKER DANGEROUS VOLTAGE	
35	LB1104	STICKER CAUTION FORK	
101	220-5643UK	COIN METER SMALL	

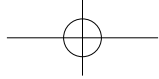

③ ASSY BASE CABINET (LCA-1100UK)

(D-1/2)

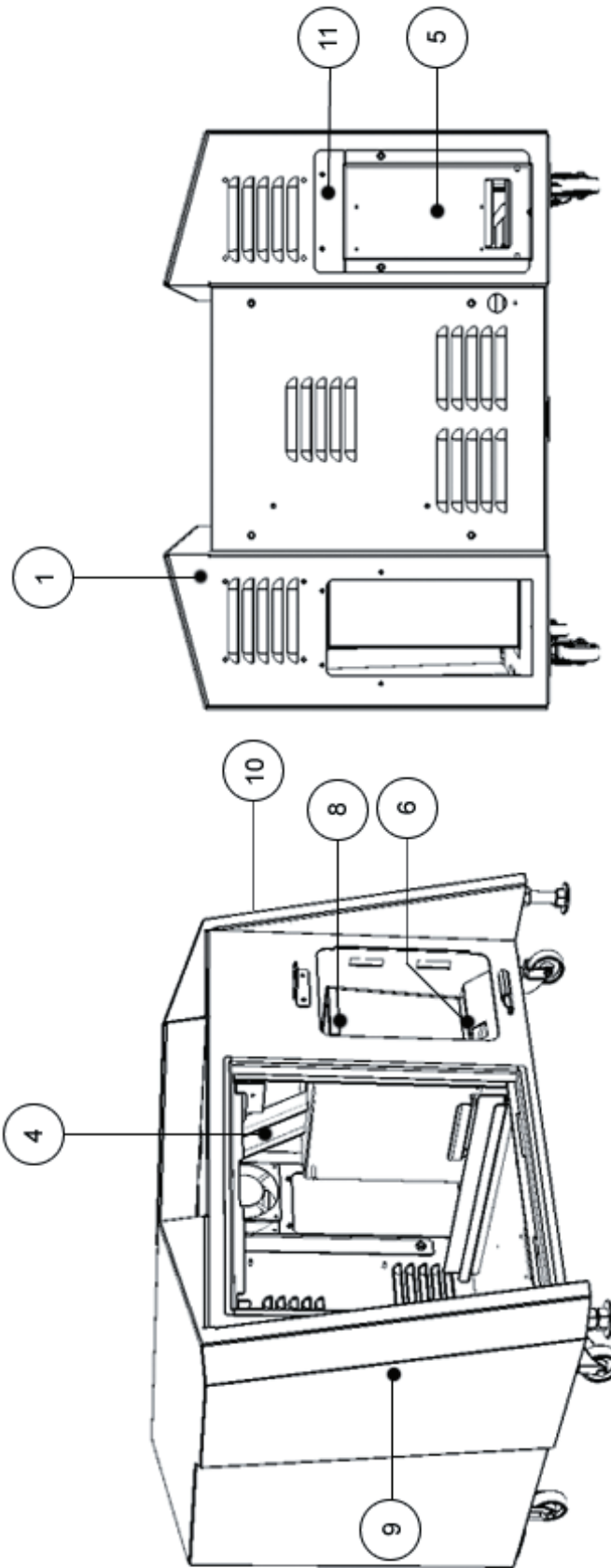

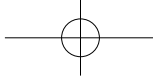

③ ASSY BASE CABINET (LCA-1100UK)

(D-2/2)

15
Parts list

ITEM NO.	PART NO.	DESCRIPTION	NOTE
1	LCB-1150UK	ASSY BASE BOX	
4	LCB-1101UK	REJECT DUCT	
5	LCB-1102UK	COM BRKT	
6	LCA-1103UK	FLOOR LID	
8	PP1087	BAX CASH FOR MINI DOOR	
9	LCB-1152UK	STICKER BASE UNIT L	
10	LCB-1153UK	STICKER BASE UNIT R	
11	LCB-1109UK	PLATE COM BRKT COVER	

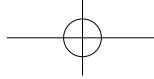

④ ASSY BASE BOX (LCA-1150UK)

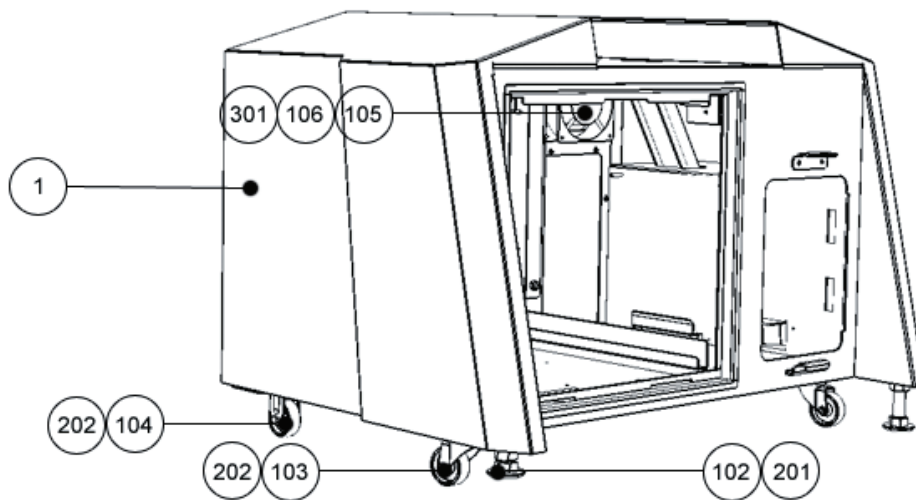

ITEM NO.	PART NO.	DESCRIPTION
1	LCB-1151UK	BASE BOX LBG
102	601-5699X	LEG ADJUSTER BOLT M16X75 SEGA
103	601-11635X-SUK	CASTOR 50 SWIVEL (BLACK)
104	601-11635X-FUK	CASTOR 50 FIXED (BLACK)
105	FN102	FAN GUARD
106	260-0011-02	AC FAN 100V
201	050-H01600	M16 NUT PAS
301	LGJ-60036UK	WH BILLBOARD FAN AC

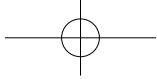

5 ASSY SERVICE DOOR (LCB-1270UK)

15
Parts list

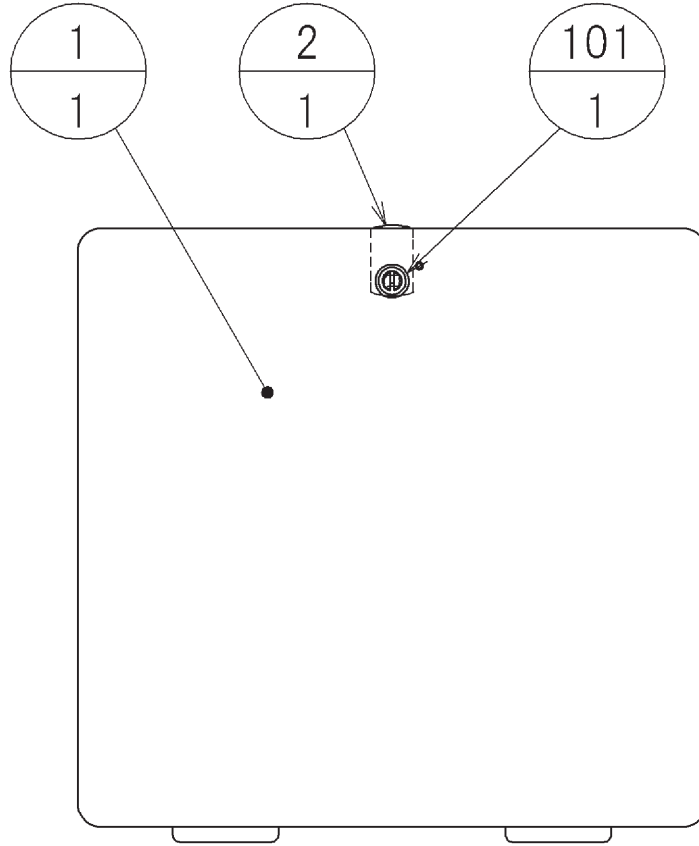

ITEM NO.	PART NO.	DESCRIPTION
1	LCB-1271UK	SERVICE DOOR
2	DP-1167UK	TNG LKG
101	220-5575UK	LOCK (J9117) W/KEY

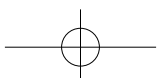

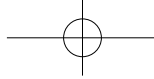

⑥ ASSY AC UNIT (LCB-1300UK)

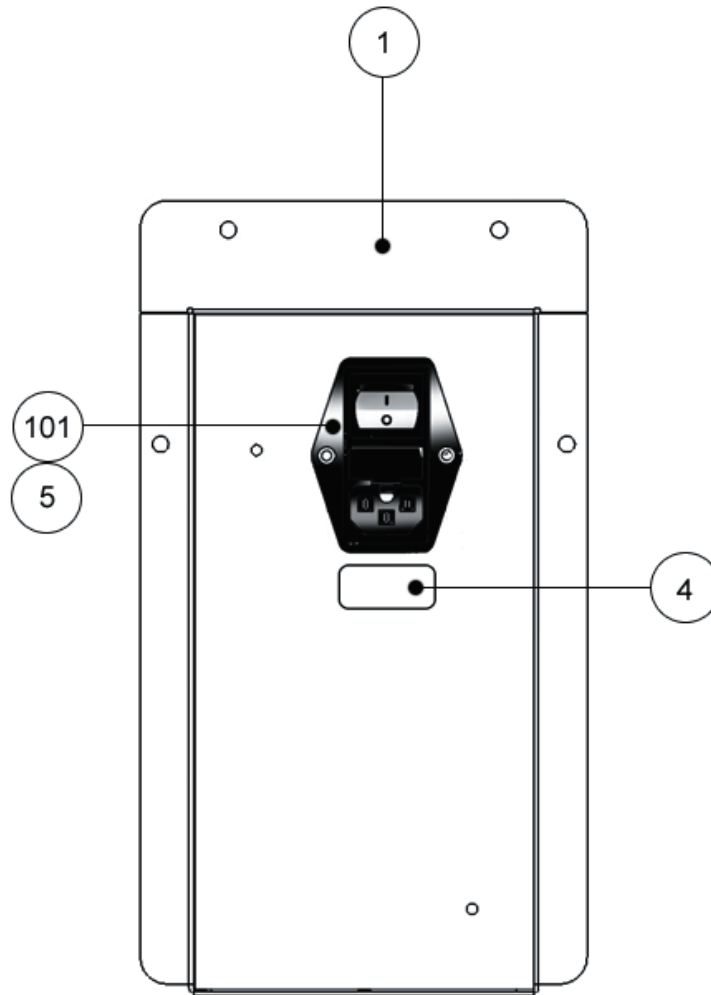

ITEM NO.	PART NO.	DESCRIPTION
1	LCB-1301UK	AC BRKT
3	LB1096	STKR PROTECT EARTH (NOT SHOWN)
101	EP1381	FILTER IEC & SW 6A ROXBURGH
301	LCA-60001UK	WH AC BKT (NOT SHOWN)
302	600-9010-44K	WH EARTH 100MM M4/M4 (NOT SHOWN)

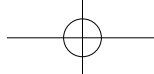

7 ASSY REAR FRAME (LCB-1500UK)

15

Parts list

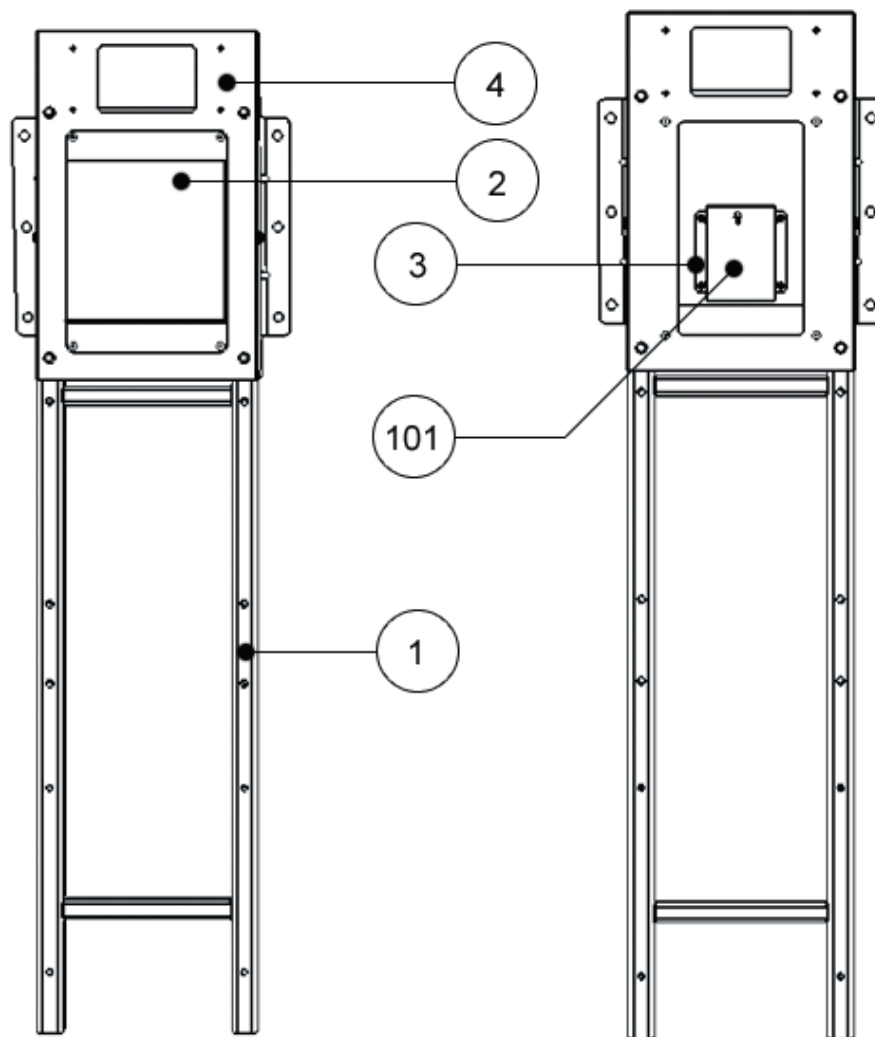

ITEM NO.	PART NO.	DESCRIPTION
1	LCB-1501UK	REAR FRAME
2	LCB-1502UK	MONITOR SUPPORT LID
3	105-5549UK	SW REG BRKT LCA
4	LCB-1511UK	BRKT MONITOR SUPPORT
101	400-5461-01	SW REG FOR LCD 32TYPE
301	LCA-60017UK	WH LCD POWER 24V
302	600-9010-44K	WH EARTH 100MM M4/M4
303	600-9025-44K	WH EARTH 250MM M4/M4
304	600-9090-44K	WH EARTH 900MM M4/M4

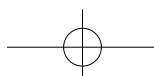

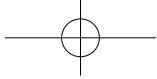

8 ASSY MONITOR 32" (LCA-1600UK)

(D-1/2)

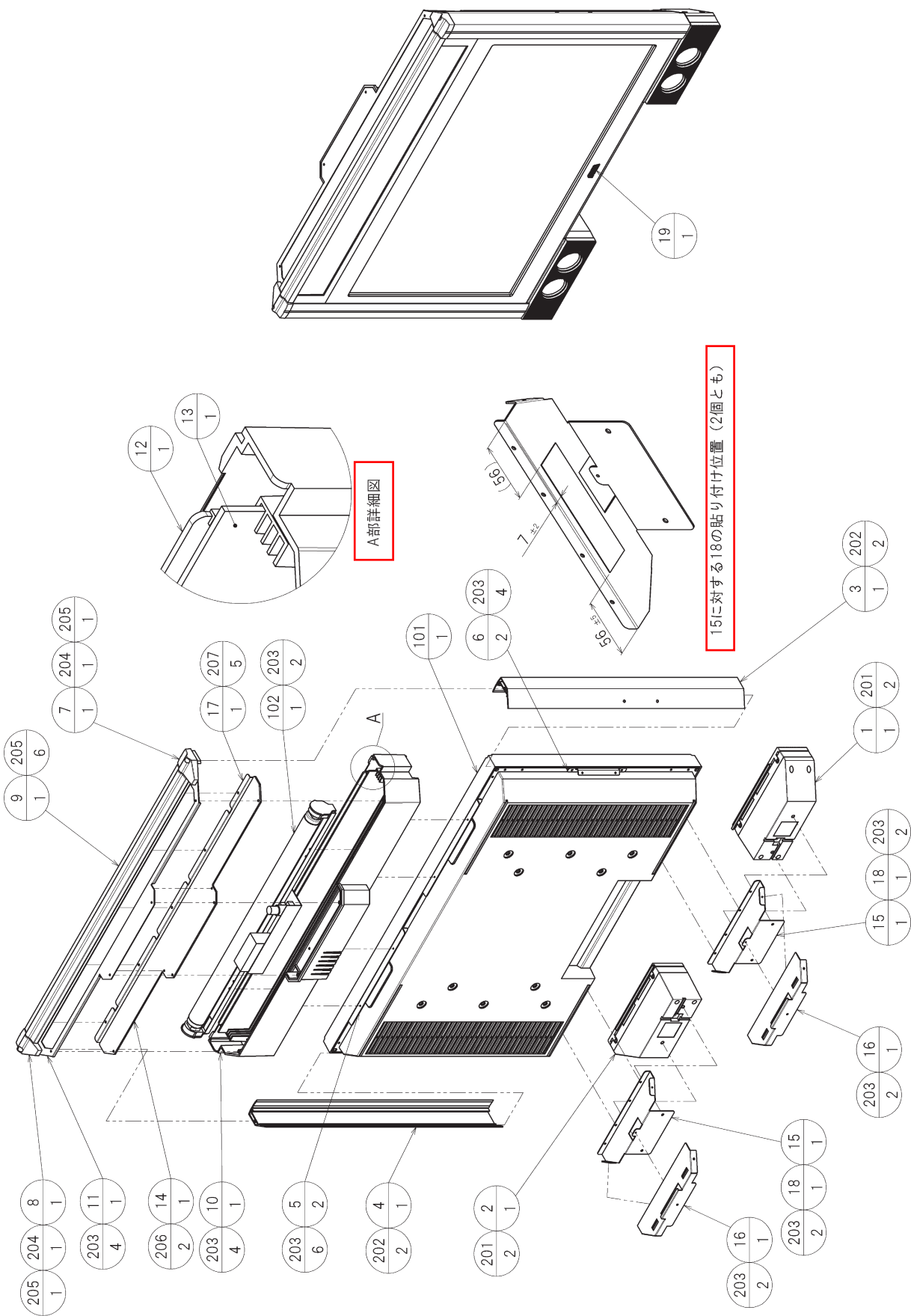

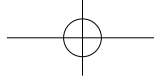

8 ASSY MONITOR 32" (LCA-1600UK)

(D-2/2)

15
Parts list

ITEM NO.	PART NO.	DESCRIPTION
1	LCA-1650UK	ASSY SPEAKER L
2	LCA-1660UK	ASSY SPEAKER R
3	LCA-1602UK	LCD SIDE FRAME LCX L
4	LCA-1603UK	LCD SIDE FRAME LCX R
5	LCA-1604UK	LIGHT BOX BRKT
6	LCA-1605UK	AL HOLD BRKT
7	140-5090	END CAP L
8	140-5091	END CAP R
9	140-5092	HORIZONTAL FRAME 32V
10	LCA-1601UK	LIGHT BOX
11	LCA-1606XUK	LID LIGHT BOX
12	LCA-1607XUK	FRONT LIGHT PLATE
13	LCA-1608X	DISPLAY PLATE LCX
14	LCA-1609UK	WINDOW PLATE BLBD FRONT LIGHT
15	LCA-1610XUK	SPEAKER BRKT LCX A
16	LCA-1611UK	SPEAKER BRKT LCX B
17	LCA-1612UK	WINDOW PLATE BRKT
19	423-0355	EMBLEM SEGA
101	200-6046	ASSY LCD DSPL 32TYPE K
102	390-0100-18XUK	ASSY FL TRAY LCB 100V 18W
103	390-0100-18DUK	FL TUBE 18W T8 600MM
201	000-P00412-WB	M SCR PH W/FS BLK M4×12
202	000-T00408-0C	M SCR TH CRM M4×8
203	000-P00312-WB	M SCR PH W/FS BLK M3×12
204	010-P00316-F	S-TITE SCR PH W/F M3×16
205	012-P00308-0B	TAP SCR #2 PH BLK 3×8
206	050-F00300	FLG NUT M3
207	000-P00306-W	M SCR PH W/FS M3×6
301	LCA-60013UK	WH SP MONITOR

9 ASSY SPEAKER L (LCA-1560UK)

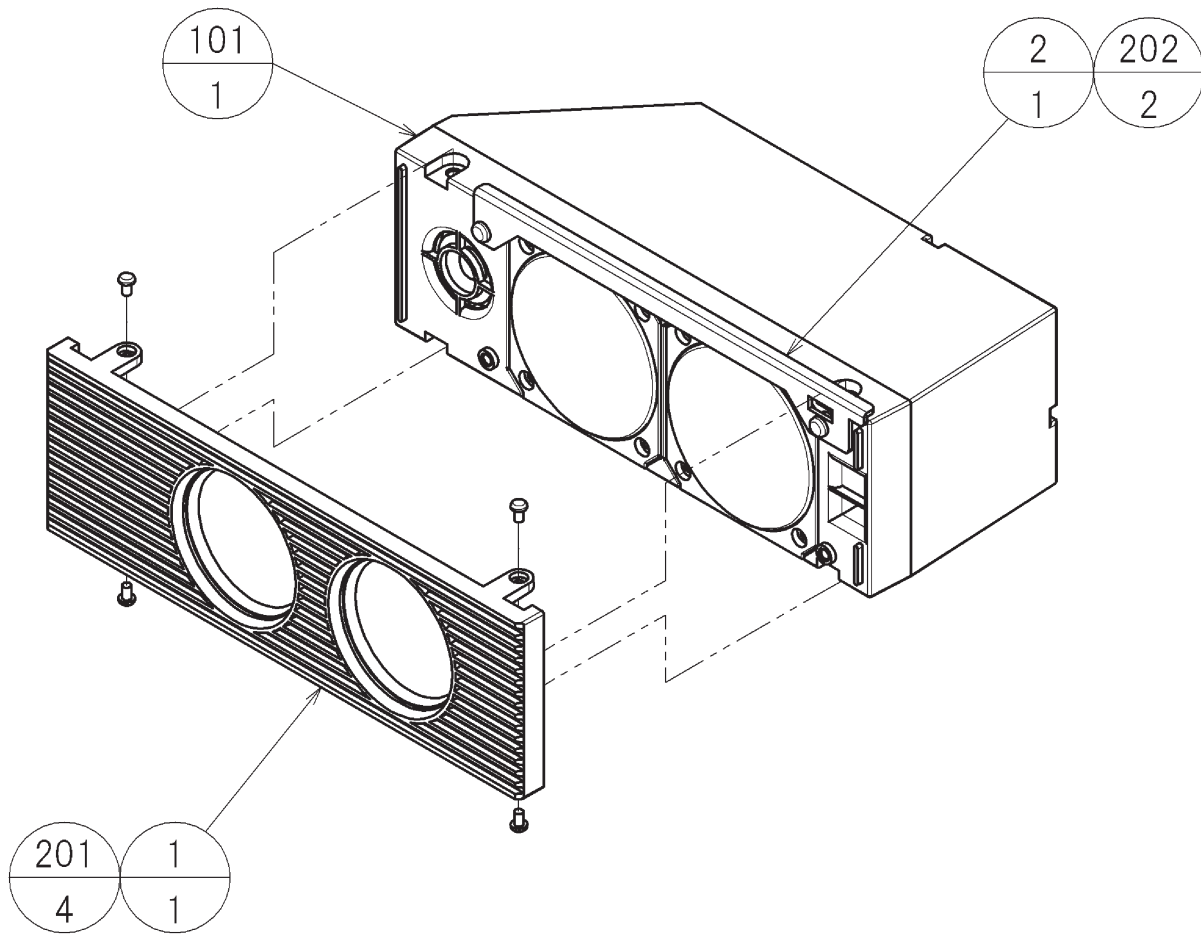

ITEM NO.	PART NO.	DESCRIPTION
1	140-5089	SPEAKER COVER FOR 130-5260
2	LCA-1651YUK	SPEAKER HOOK L
101	130-5260	SPKR BOX 6OHM 15/40W W/SHLD
201	000-P00305	M SCR PH M3×5
202	012-P00406	TAP SCR #2 PH 4×6

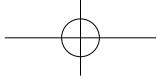

⑩ ASSY SPEAKER R (LCA-1660UK)

15
Parts list

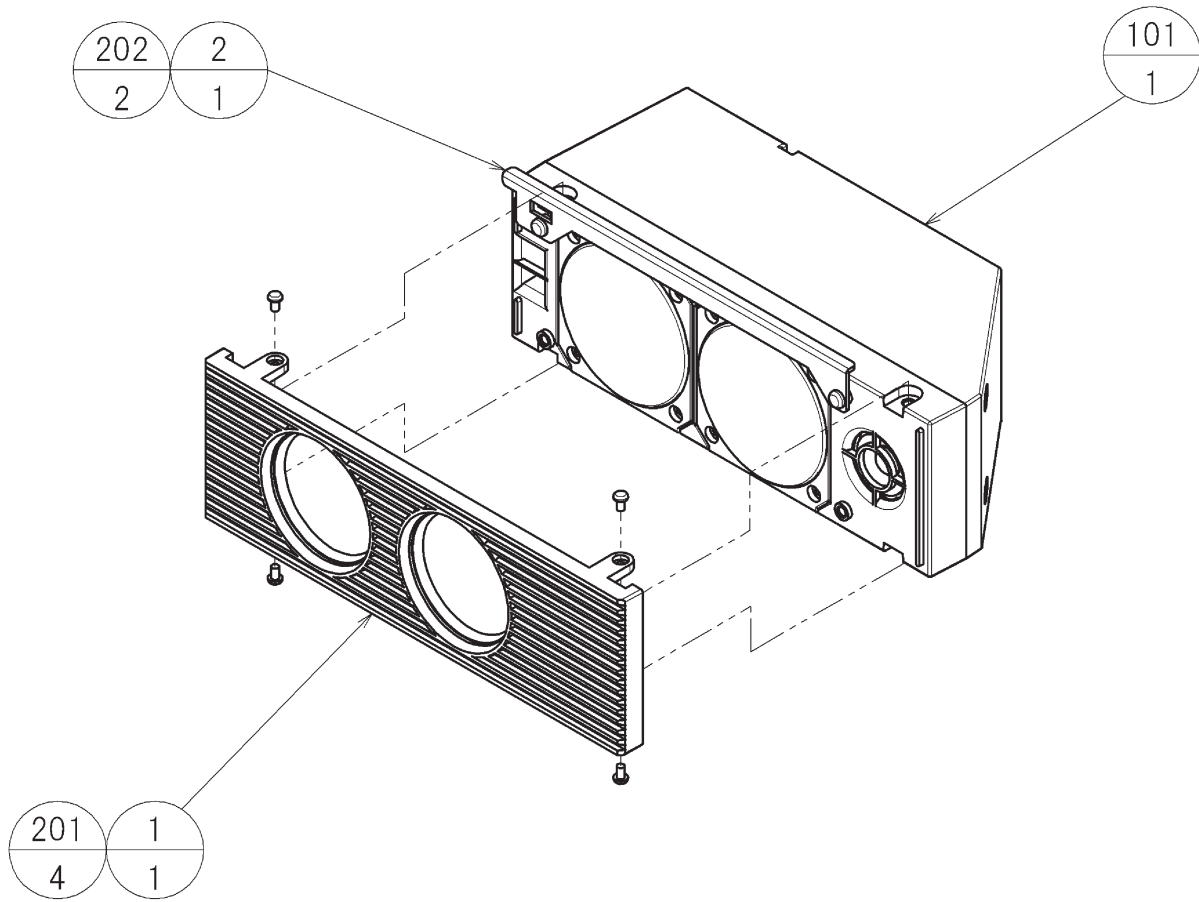

ITEM NO.	PART NO.	DESCRIPTION
1	140-5089	SPEAKER COVER FOR 130-5260
2	LCA-1661YUK	SPEAKER HOOK R
101	130-5260	SPKR BOX 6OHM 15/40W W/SHLD
201	000-P00305	M SCR PH M3×5
202	012-P00406	TAP SCR #2 PH 4×6

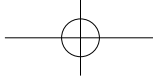

11 ASSY BILLBOARD W/O DESIGN (LCA-1700UK)

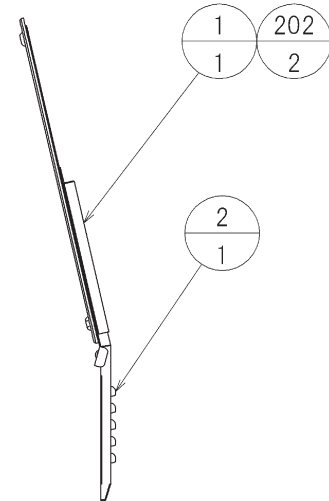
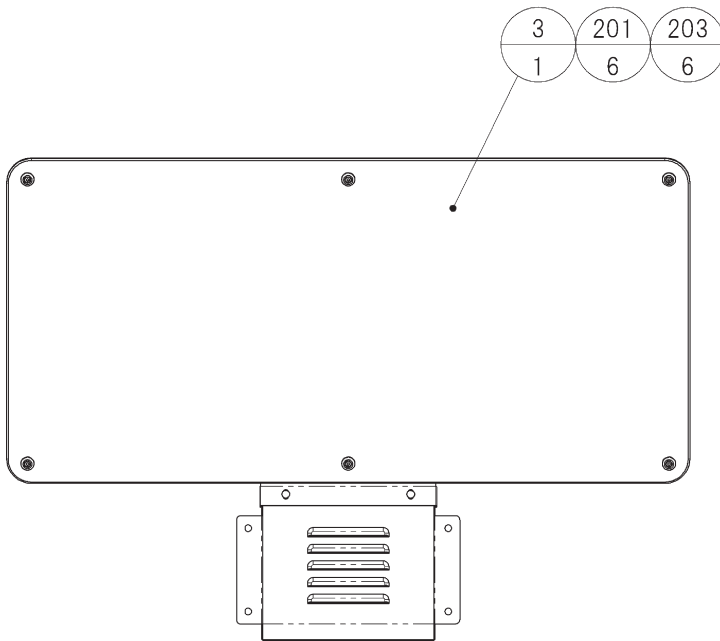

15 Parts list

ITEM NO.	PART NO.	DESCRIPTION
1	LCA-1701UK	BILLBOARD BASE
2	LCA-1702UK	BILLBOARD HOLDER
3	LCA-1703UK	BILLBOARD FRONT PLATE
201	FAS-290045	HEX SKT LH CAP SCR STN M4×6
202	000-T00408-0B	M SCR TH BLK M4×8
203	280-6686-01	SP WSHR 4.5×16×4

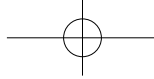

12 ASSY CONTROL BOX (LCB-2000UK)

15 Parts list

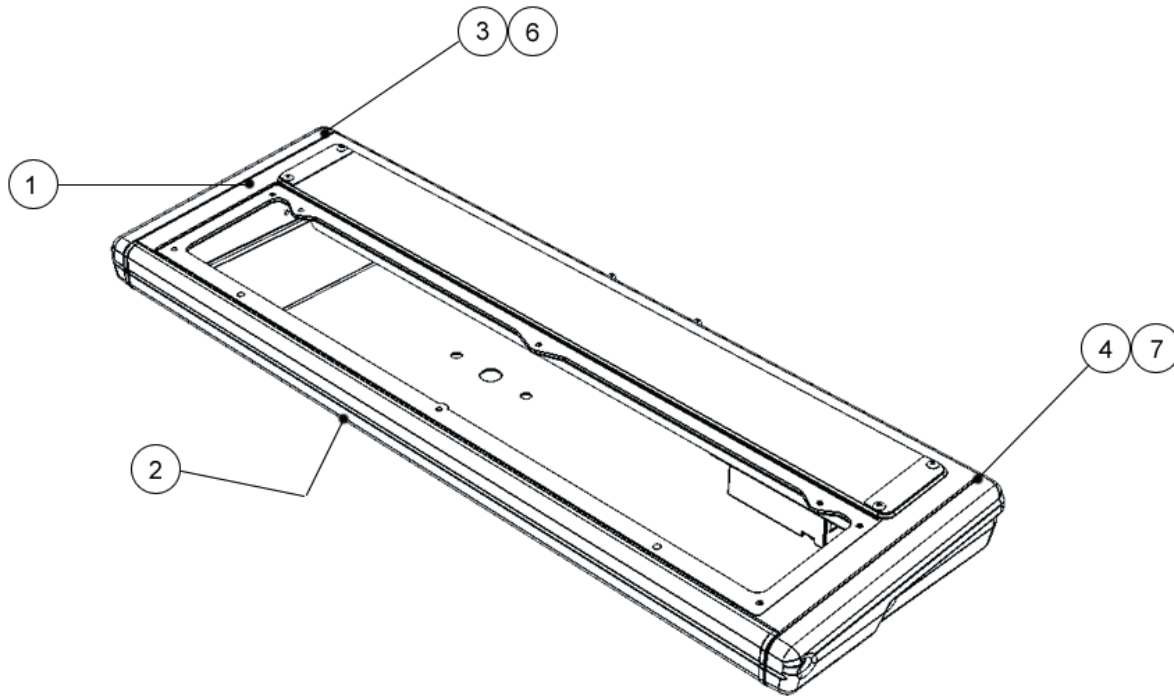

ITEM NO.	PART NO.	DESCRIPTION
1	LCA-2030UK	ASSY CONTROL BOX UPPER
2	LCA-2060UK	ASSY CONTROL BOX LOWER
3	LCA-2001UK	HINGE PLATE L
4	LCA-2002UK	HINGE PLATE R
6	LCA-2004UK	SIDE COVER L
7	LCA-2005UK	SIDE COVER R
201	000-P00408-W	M SCR PH W/FS M4×8
202	012-P00412	TAP SCR #2 PH 4×12

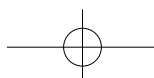

⑬ ASSY CONTROL BOX UPPER (LCA-2030UK)

(D-1/2)

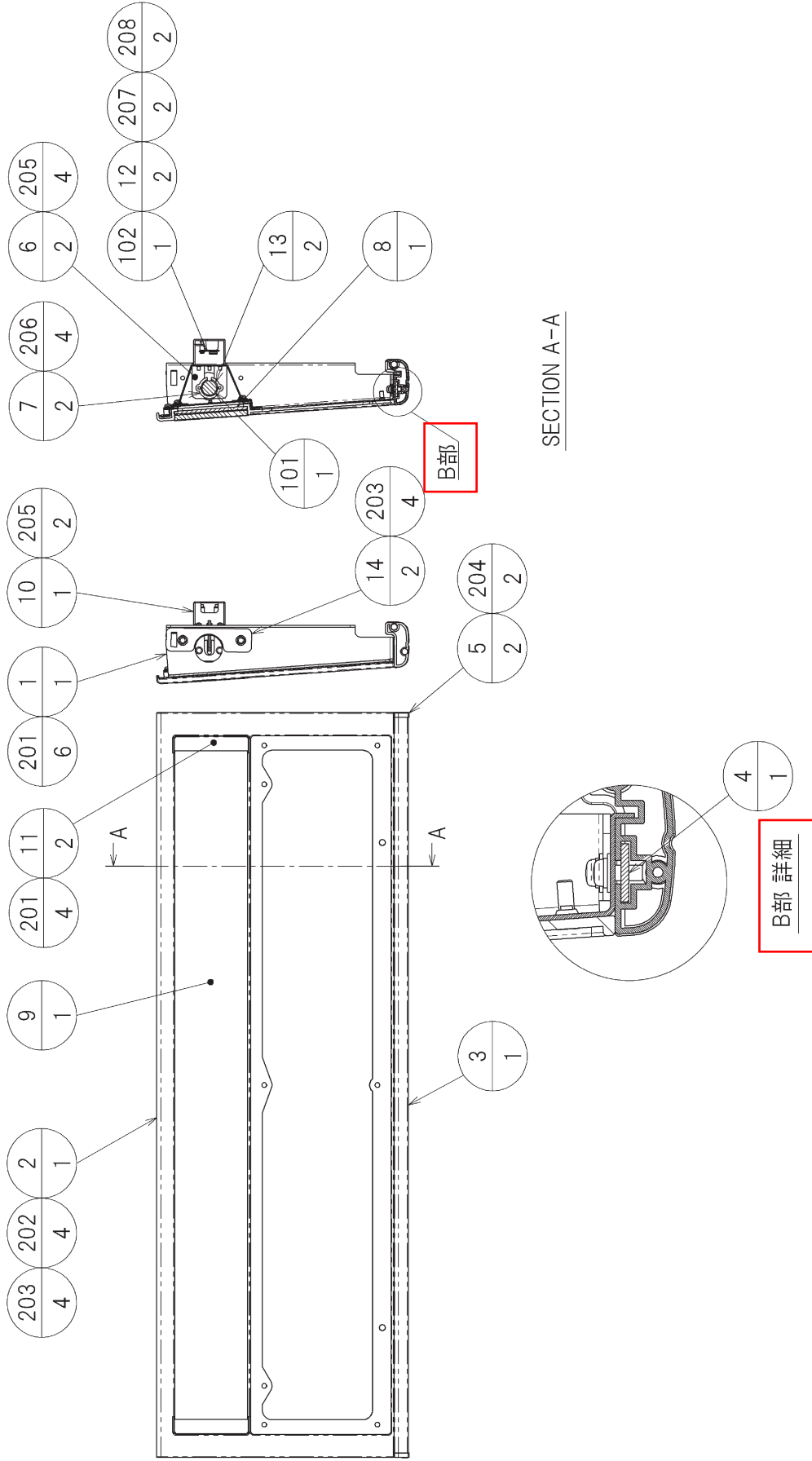

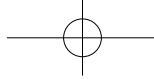

13 ASSY CONTROL BOX UPPER (LCA-2030UK)

(D-2/2)

15
Parts list

ITEM NO.	PART NO.	DESCRIPTION	
1	LCA-2031UK	CONTROL BOX UPPER	
2	LCA-2032X	CONTROL PANEL	
3	LCA-2033UK	FRONT LINE	
4	LCA-2034UK	NUT PLATE	
5	LCA-2035	END COVER	
6	LCA-2036UK	CCFL HOLDER (OPTION)
7	LCA-2037UK	CCFL CAP	(OPTION)
8	LCA-2038UK	DIFFUSION PLATE	
9	LCA-2039XUK	INSTRUCTION COVER	
10	LCA-2040UK	INVERTER COVER	(OPTION)
12	SHE-1238	SPACER COLLAR	
14	LCA-2042UK	TONGUE RETAINER	
101	390-6815-WH-V	CCFL D=15 L=700 WHITE W/V.TUBE	(OPTION)
102	838-14587	CCFL INV	(OPTION)
103	280-5275-SR10	CORD CLAMP SR10	(OPTION)
201	000-P00410-W	M SCR PH W/FS M4×10	
202	000-F00306	M SCR FH M3×6	
203	000-P00408-W	M SCR PH W/FS M4×8	
204	010-F00312	S-TITE SCR FH M3×12	
205	000-P00308-W	M SCR PH W/FS M3×8	
206	012-P00308	TAP SCR #2 PH 3×8	
207	000-P02610	M SCR PH M2.6×10	
208	FAS-680011	FLT WSHR POLY 2.7-6×0.5	
301	LCA-60022UK	WH COLD CATHODE CONTROL	(OPTION)

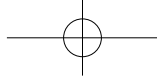

14 ASSY CONTROL BOX LOWER (LCA-2060UK)

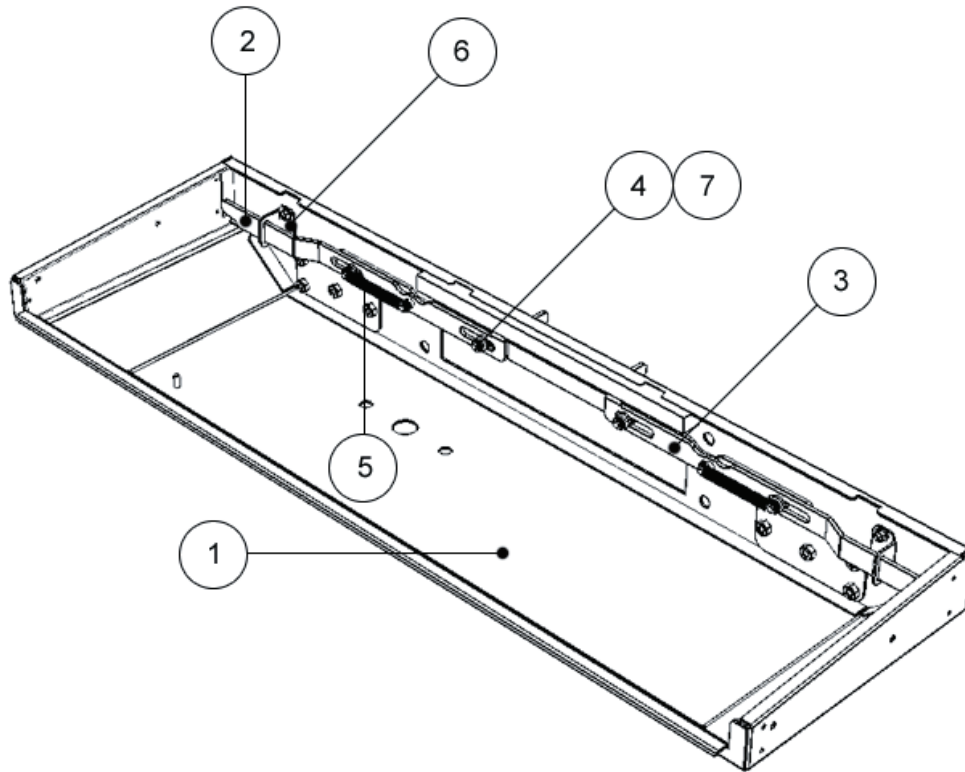

15 Parts list

ITEM NO.	PART NO.	DESCRIPTION
1	LCA-2061UK	CONTROL BOX LOWER
2	LCA-2062YUK	SLIDE TONGUE L
3	LCA-2063YUK	SLIDE TONGUE R
4	LCA-2064UK	TONGUE SPACER
5	LCA-2065	TONGUE SPRING
6	LCA-2066UK	TONGUE GUIDE
7	LCA-2067	TONGUE ROLLER
201	000-P00416-W	M SCR PH W/FS M4×16
202	000-P00408-W	M SCR PH W/FS M4×8
203	050-F00400	FLG NUT M4

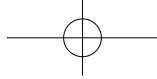

15 ASSY ENTRY BOX (LCB-2100UK)

15 Parts list

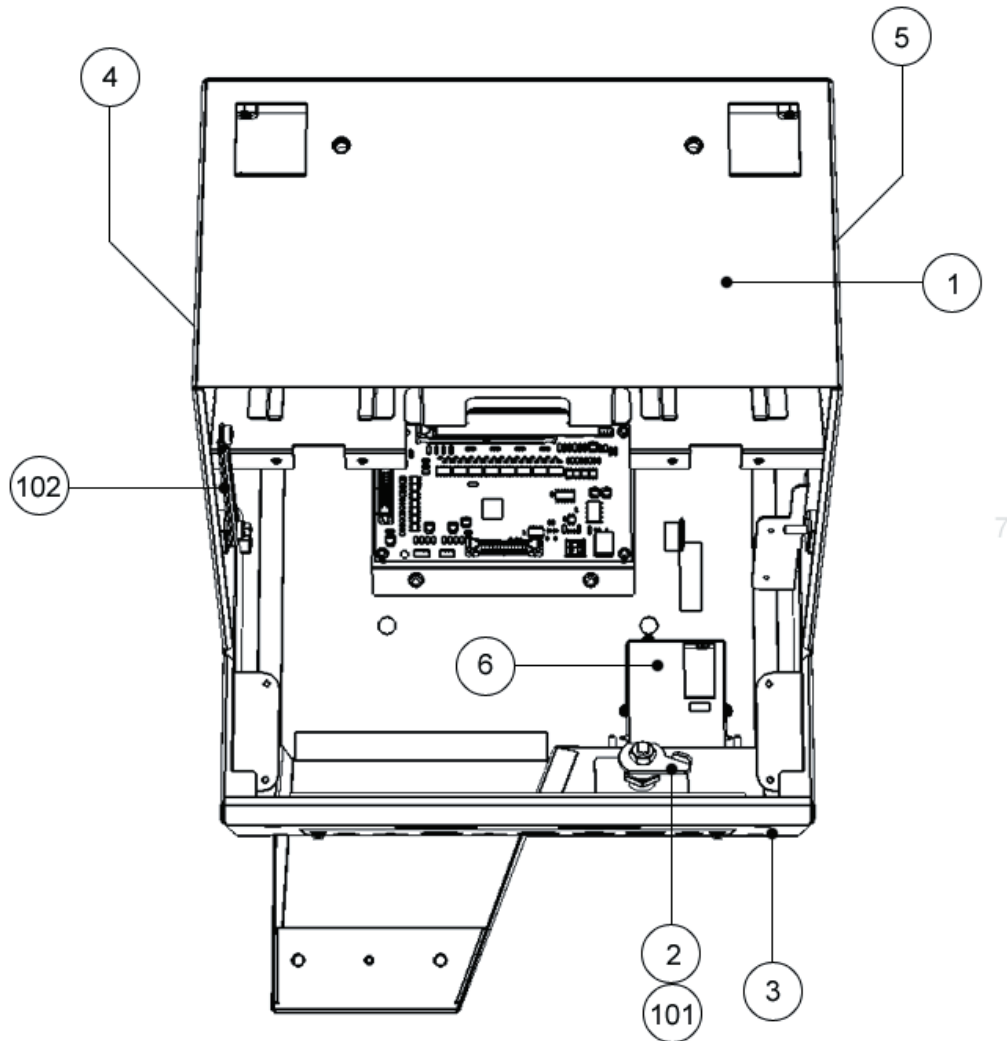

ITEM NO.	PART NO.	DESCRIPTION
1	LCA-2101XUK	ENTRY BOX
2	LCA-2102UK	TONGUE
3	LCA-2103UK	CONN PANEL PLATE
4	LCA-2104UK	STICKER ENTRY UNIT L
5	LCA-2105UK	STICKER ENTRY UNIT R
101	220-5575UK	LOCK (J9117) W/KEY
102	601-11440	STAY
201	000-P00408-W	M SCR PH W/FS M4×8
202	050-F00400	FLG NUT M4

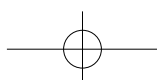

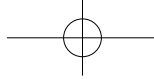

16 ASSY ENTRY LID (LCB-2150UK)

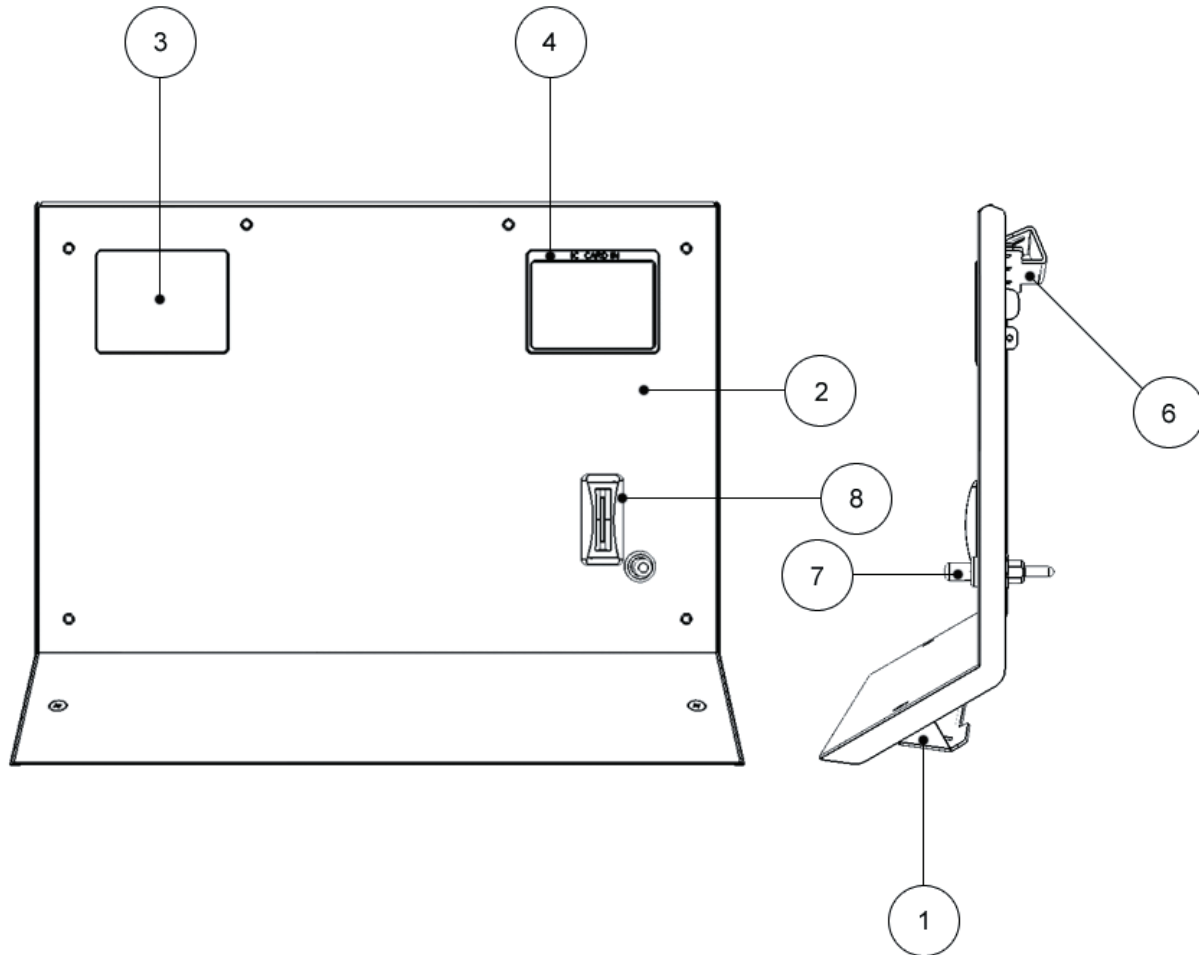

ITEM NO.	PART NO.	DESCRIPTION
1	LCA-2151UK	ENTRY LID
2	LCA-2152UK	LID FRONT PANEL
3	LCA-2153	FLAT LID (USED WHEN NO CARD RW FITTED)
4	LCA-2154	OPEN LID
6	LCA-2158UK	PLATE LID HOOK
7	250-5669	ASSY REJECT BUTTON L59
8	220-5428-09	COIN ENTRY
10	LCB-2157UK	STICKER ENTRY UNIT FRONT
201	000-P00408-W	M SCR PH W/FS M4×8
202	000-P00310-W	M SCR PH W/FS M3×10
203	000-P00306-W	M SCR PH W/FS M3×6

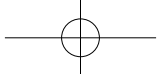

17 ASSY COIN SELECTOR (LCB-2170UK)

15 Parts list

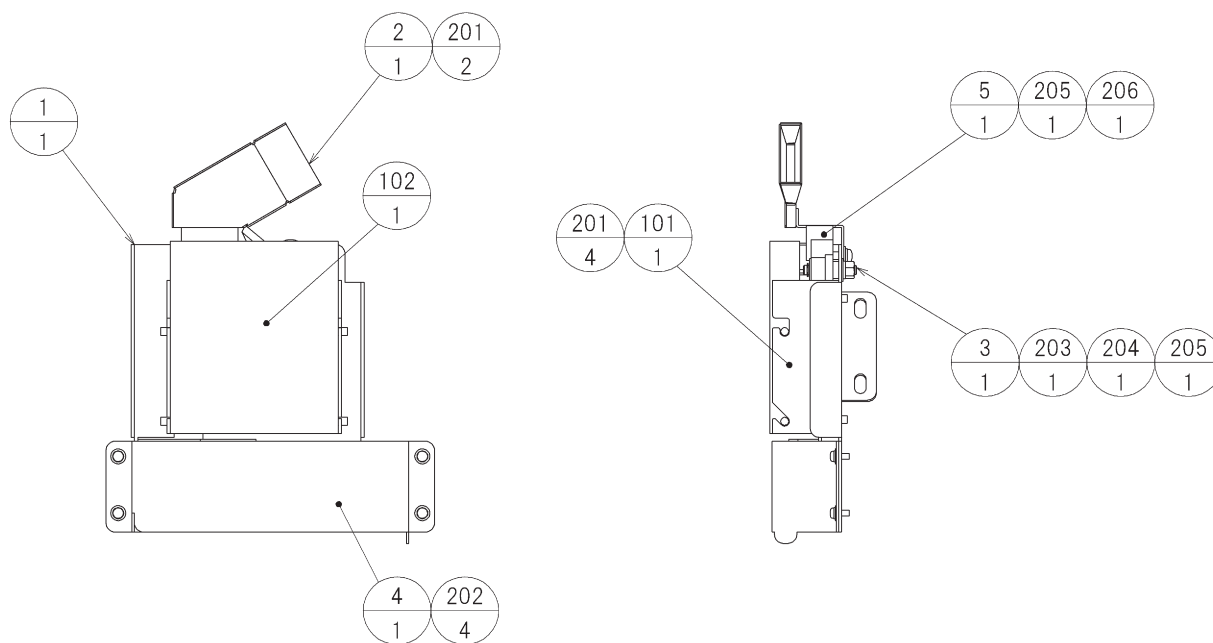

ITEM NO.	PART NO.	DESCRIPTION
1	LCA-2171UK	COIN SELECTOR BASE
2	LCA-2172UK	UPPER COIN CHUTE
3	CFB-1683	REJECT SHAFT
4	LCA-2174UK	LOWER COIN CHUTE
5	VSC-1474UK	REJECT CAM
103	EP1380-R	CREDIT BD EXCEL
104	280-L01640-PS	STANDOFF 16MM 4MM PANEL SMALL
201	000-P00408-W	M SCR PH W/FS M4×8
202	000-P00308-W	M SCR PH W/FS M3×8
203	050-H00500	HEX NUT M5
204	060-S00500	SPR WSHR M5
205	060-F00500	FLT WSHR M5
206	065-E00300	E RING 3MM
301	LCA-60021UK	WH EXCEL CREDIT BOARD

18) ASSY SWITCH UNIT (LCA-2180UK)

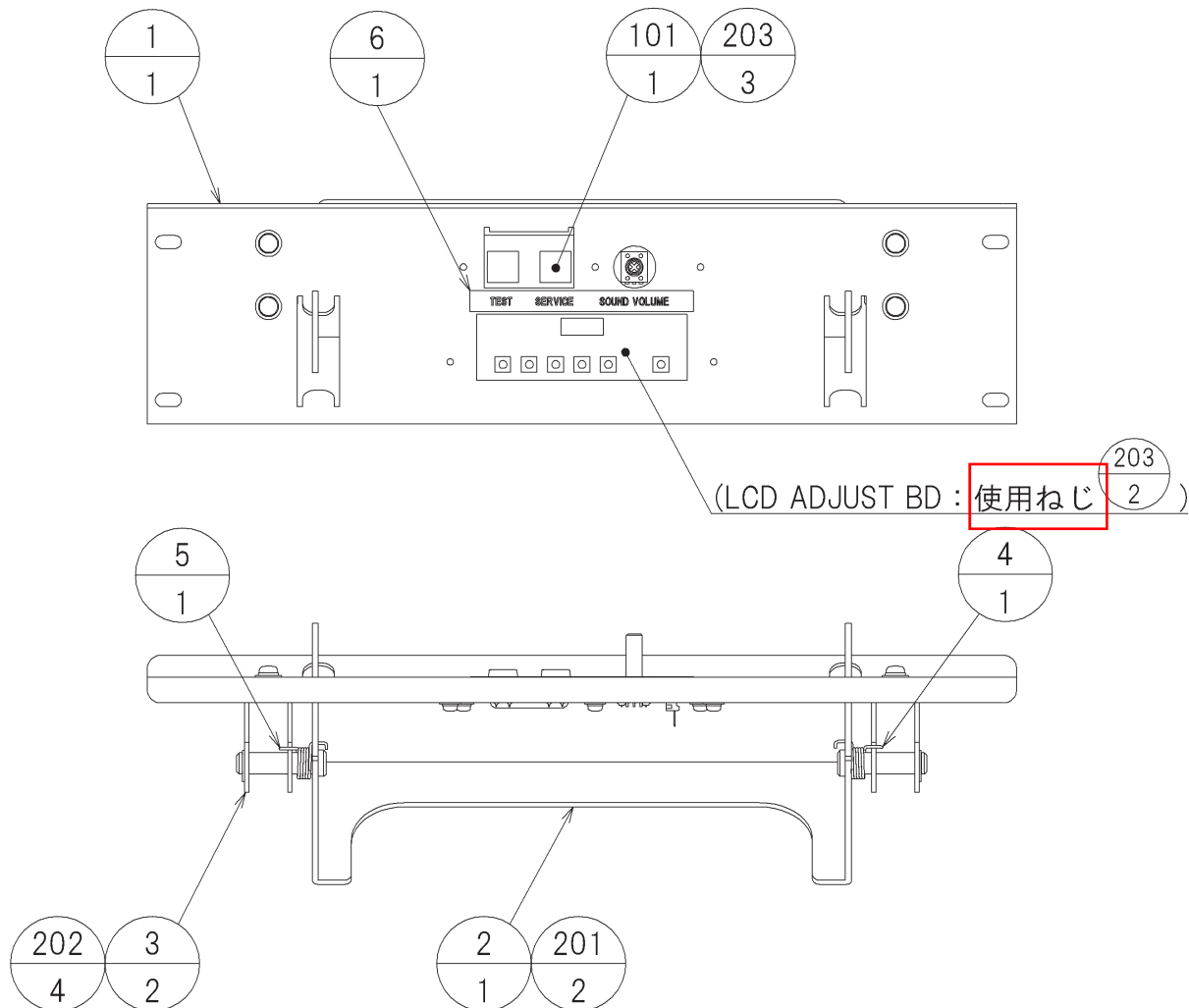

ITEM NO.	PART NO.	DESCRIPTION
1	LCA-2181UK	SW BRKT
2	LCA-2182XUK	LATCH
3	LCA-2183UK	LATCH HOLDER
4	CTF-1173	LATCH SPRING L
5	CTF-1174	LATCH SPRING R
6	421-12136UK	STICKER SW PANEL LCA
101	838-14548-01UK	SW & C VOL BD
201	065-E00700	E RING 7MM
202	000-P00408-W	M SCR PH W/FS M4×8
203	000-P00308-W	M SCR PH W/FS M3×8

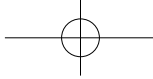

19 ASSY I/O UNIT (LCA-2190UK)

15
Parts list

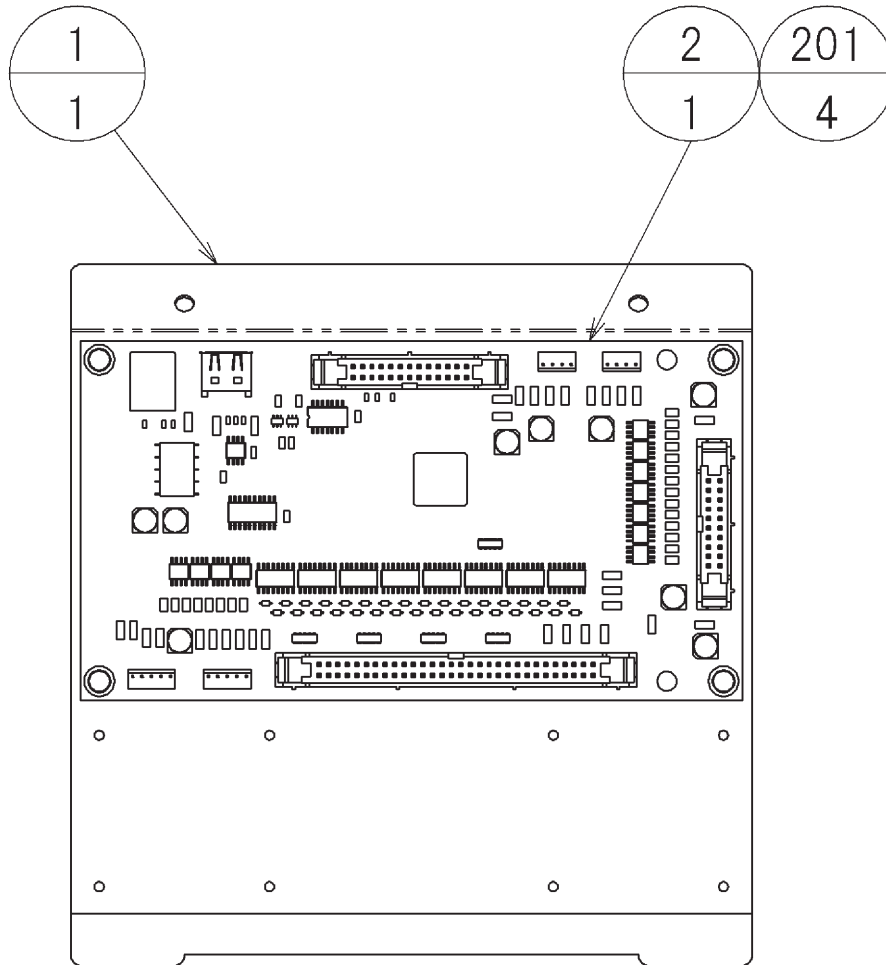

ITEM NO.	PART NO.	DESCRIPTION
1	LCA-2191	IO BD BASE
2	837-14572	I/O CONTROL BD 3 FOR JVS COM
201	000-P00320-W	M SCR PH W/FS M3×20

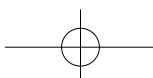

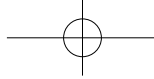

20 ASSY POWER SUPPLY (LCA-4000UK)

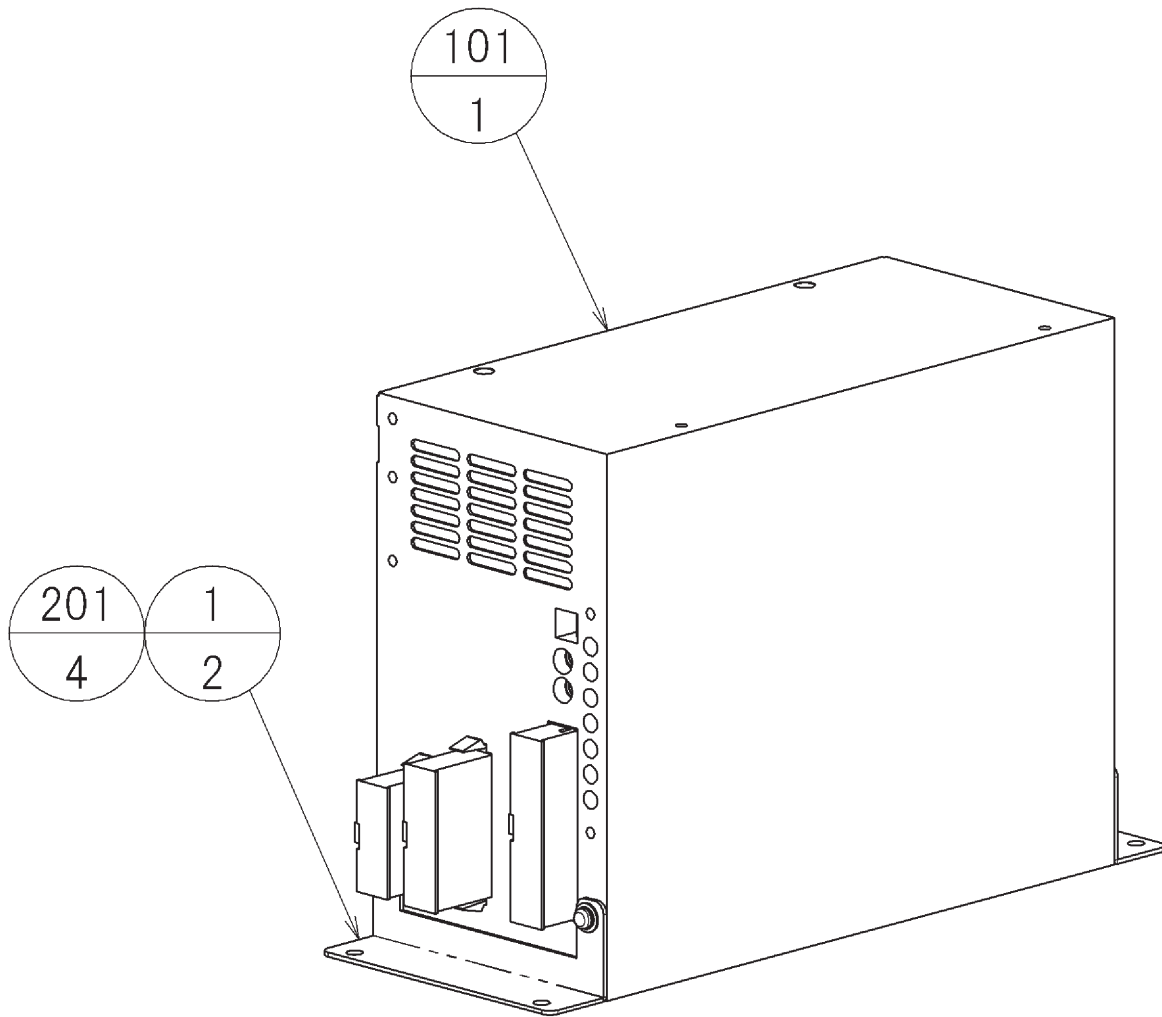

ITEM NO.	PART NO.	DESCRIPTION
1	SHT-4904	ELEC BRKT
101	400-5457-01	SW REGU ATX/JVS AUTO
201	000-P00308-W	M SCR PH W/FS M3×8

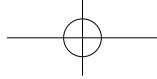

21 ASSY SUB ELEC (LCA-4050UK)

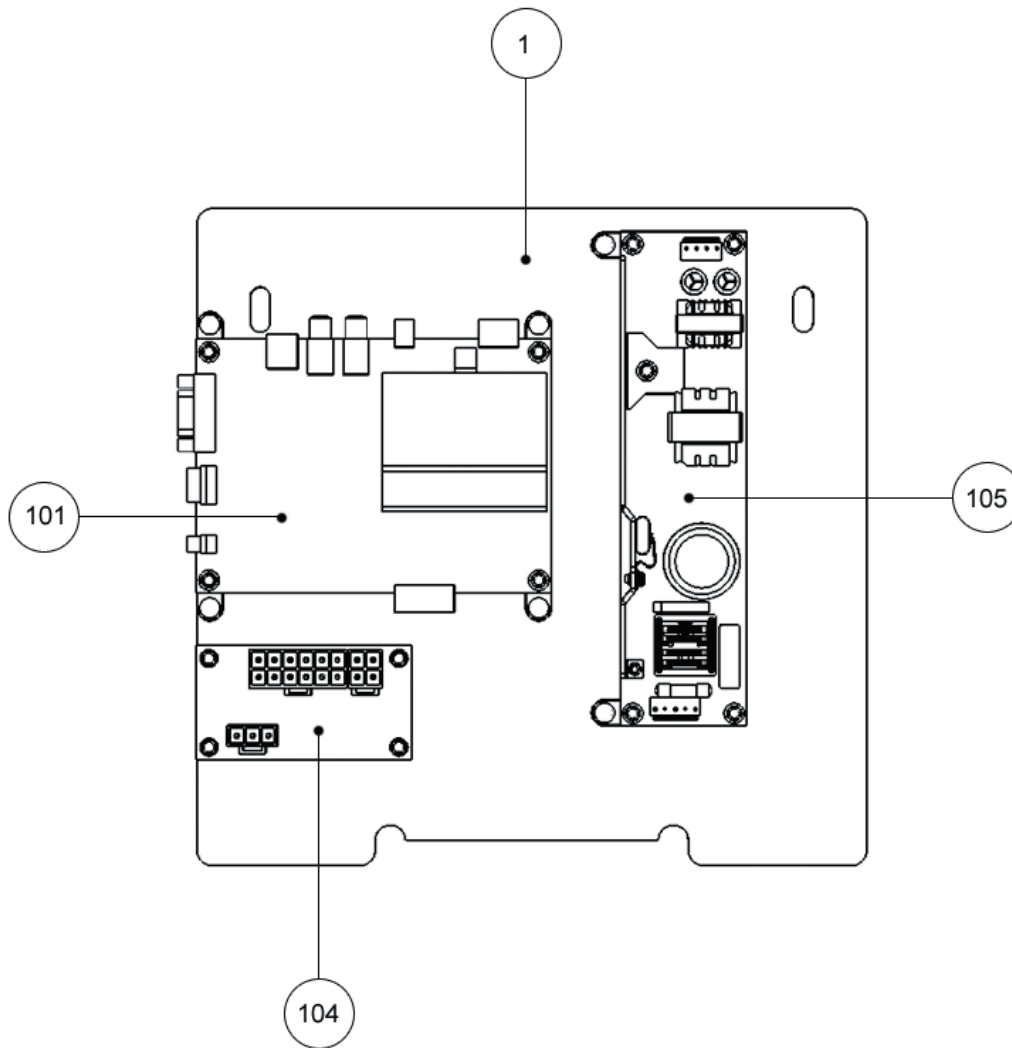

ITEM NO.	PART NO.	DESCRIPTION
1	LCA-4051UK	WOODEN BASE SUB ELEC
101	838-14515-A0191	SOUND AMP ANALOG IN
104	838-14551	DISTRIBUTION BD
105	400-050-024-01	PSU 24VDC 50W MW LPS 50-24
201	000-P00308-W	M SCR PH W/FS M3×8
202	011-T03516	TAP SCR TH 3.5×16
203	011-P00320	TAP SCR PH 3×20
301	LCA-60007UK	WH AC SUB ELEC SW REGU FOR AMP
303	LCA-60010UK	WH DC SUB ELEC SW REGU FOR AMP
304	LCA-60012UK	WH SPEAKERS
305	LCA-60026UK	WH AC DIST
306	600-7158-0200	CA AUDIO RCA TO RCA 2CH 200CM

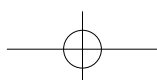

23 ASSY CONTROL PANEL 2L6B (LCB-2500UK)

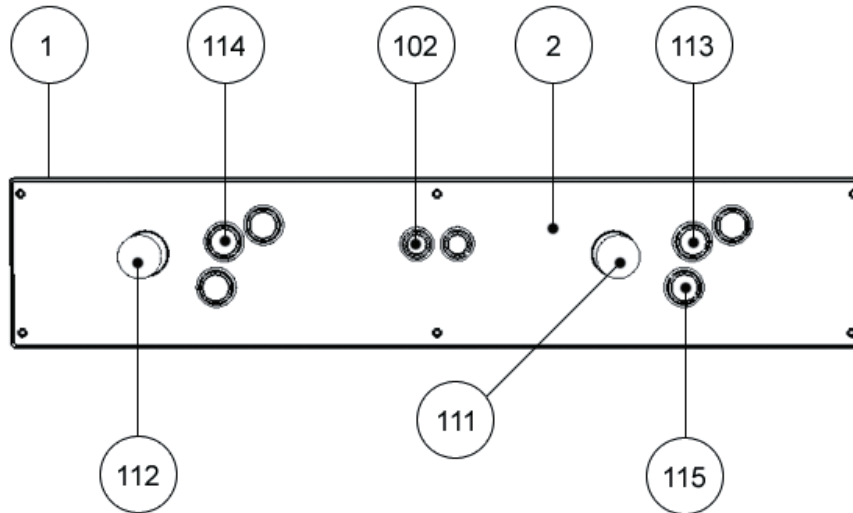

ITEM NO.	PART NO.	DESCRIPTION
1	LCA-2501UK	CTRL PNL BASE 2L6B
2	LCA-2502UK	CTRL PNL PLATE 2L6B
102	509-5765-01	SW PB D24 YELLOW
111	610-0404-01	ASSY 8 WAY JOYSTICK GREEN
112	610-0404-02	ASSY 8 WAY JOYSTICK PINK
113	509-5755-01	SW PB D30 GREEN
114	509-5755-02	SW PB D30 PINK
115	253-5185UK	CAP SW 30PH
201	000-P00412-W	M SCR PH W/FS M4×12
301	LCA-60023UK	WH CONTROL PANEL 1
302	LCA-60024UK	WH CONTROL PANEL 2P

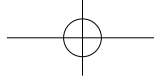

16 Wire color reference table

The wire color codes used in the overall wiring diagrams in the next chapter are as stated below.

CODE	WIRE COLOR
10	RED
20	BLUE
30	YELLOW
40	GREEN
50	WHITE
70	ORANGE
80	BLACK
90	GRAY
A	PINK
B	SKYBLUE
C	BROWN
D	PURPLE
E	LIGHT GREEN

Note 1 If the units digit of the code is non-zero, the tens digit indicates the background color and the units digit indicates the spiral color.

E.g. 51... White/Red

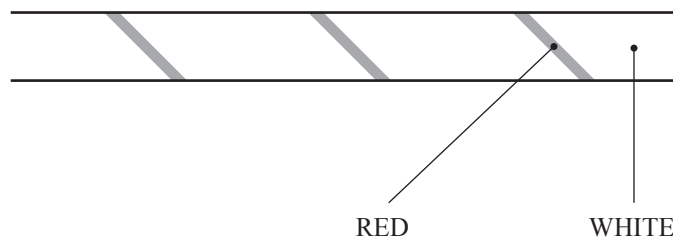

Note 2 The letter after the wire color code indicates the thickness of the wire.

U: AWG16
 K: AWG18
 L : AWG20
 None: AWG22

17 Overall wiring diagrams (D-1/2)

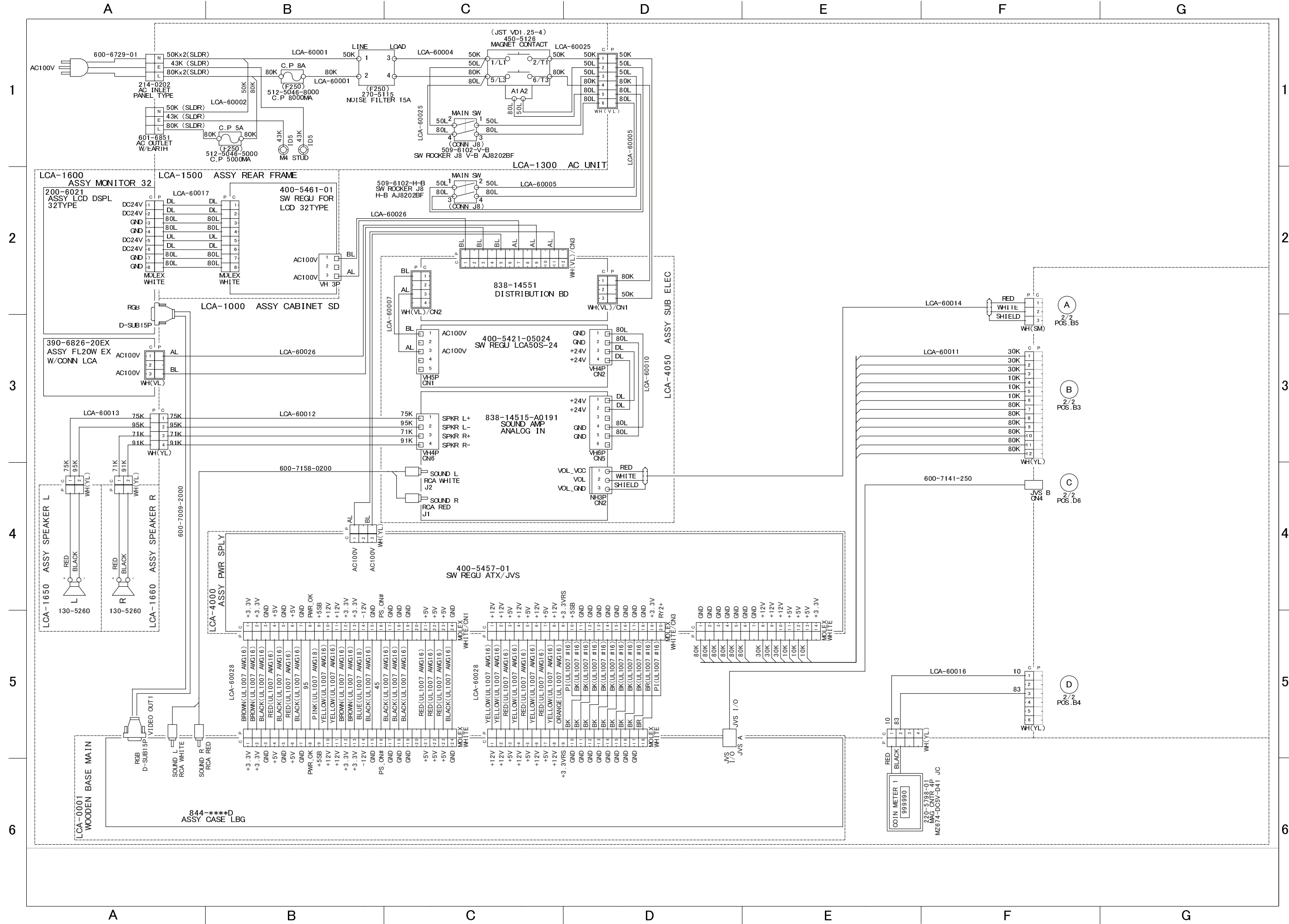

18 Overall wiring diagrams

(D-2/2)

