

This document has been downloaded from:



The largest resource for amusement machines
documentation on the world wide web!



FLIPPERSPILL.COM

Gremlin[®]/SEGA[®]

MOON CRESTA

Service Manual & Parts Catalog

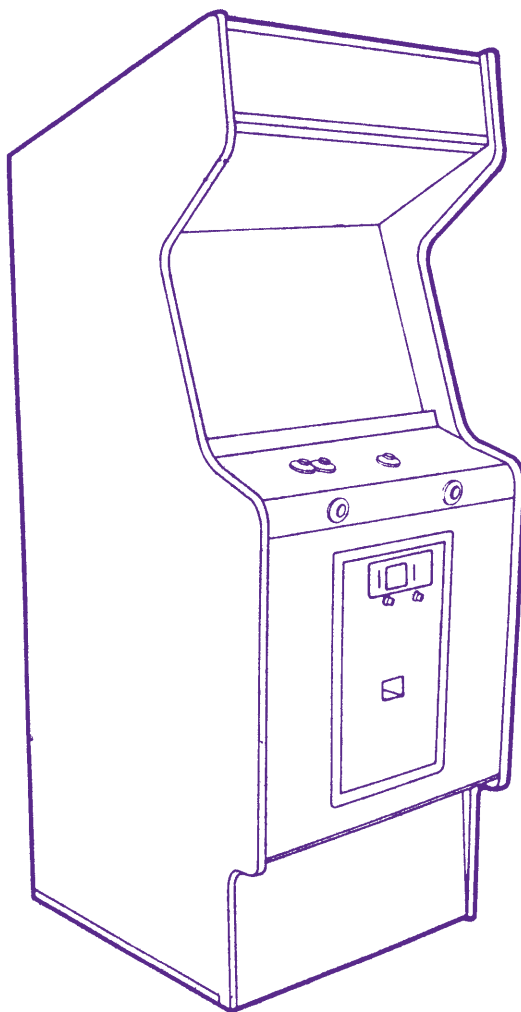

GREMLIN INDUSTRIES, INC.

CONTENTS

1. Installation	-----	2
2. Care in Operation	-----	2
3. Game Play	-----	3
4. IC Board Adjustments	-----	4
5. TV Volume Adjustments (1)	-----	5
TV Volume Adjustments (2)	-----	6
Adjustable Controls	-----	7
6. Color Monitor Troubleshooting	-----	8
7. Parts Catalog	-----	9~18
8. Schematics	-----	Following Pages

SPECIFICATIONS

* Space Requirer	-----	638 mm x 703 mm
* Game Height	-----	1722 mm
* Power Source	-----	AC 100V~240V
* CRT	-----	20 Color TV
* Power Consumption	-----	120 W

Note : These instructions and specifications may be changed without prior notification. If this machine is reconstructed without our permission, we can not take responsibility for the machine.

1 INSTALLATION

1. As the SEGA Monaco GP is for "indoor use", do not install outdoors.
2. When installing, avoid the following places.
 - Near indoor pools or showers
 - Where leaks exist
 - Under direct sunlight
 - Near heaters or other heat emitting devices
 - Where hazardous items (volatile fluids, gas cylinders etc.)
 - Where vibrations are severe (near construction sites where jack hammers etc. are used)
 - Inclined places
 - Near fire extinguishing equipment
 - Near emergency exits
 - Set power transformer changeover switch to 110V in locations where the power is normally below 90V.

2 CARE IN OPERATION

1. Inspection
 - Are the IC boards and other connectors firmly connected.
 - Connect ground wire as prescribed. (Never connect to gas pipes, water pipes or electrical conduits)
 - Arrange line cords and ground wires in the aisle so they will not be tripped over.
2. Care in Handling
 - Always turn off the power supply switch before handling.
 - Avoid inserting and pulling the plug in rapid succession.
 - Do not check the IC board circuit with a tester.
3. Care in Usage
 - Care should be taken to avoid dragging or dropping the machine when transporting to prevent damage to the CRT.
 - Use fuse of stipulated rating.
 - As high voltage is present in the monitor and TV PCB, adjustments or repairs should be left up to a serviceman and should never be touched by the layman.
 - As color alignment may become disturbed due to terrestrial magnetism when the machine is moved or its direction changed, demagnetize the unit by pushing the demagnetizing switch.
 - Refrain from holding the steering wheel or shift lever when transporting the machine.

3 Game Play

Gremlin/Sega "MOON CRESTA" is a one or two player game in which players may compete for highest score against the game computer. Each time a player is hit by an alien, the game switches to his opponent's sequence.

The object is to destroy as many of the descending aliens as possible. To accomplish this the player is given a three stage multi-fire Warship. He begins with the first stage, firing a single laser at the enemy. If he is successful in eliminating the first four sets of aliens, he is given an opportunity to dock his first stage onto the second within a specific time limit (the sooner he unites the stages, the higher is his awarded score).

Once docked, the stages combine their firing power, so the first (one laser) adds to the second (two lasers) giving the player a total of three usable lasers as the game continues.

The player then must face two more sets of aliens and a shower of meteors, after which he has a chance to dock again, this time uniting with the third stage for a combined fire power of five lasers. If he is able to defeat the last two sets of aliens intact, the entire sequence begins again. The game continues with increasing difficulty until the entire warship is destroyed. When the warship is hit the player continues with whatever stages remain. If his score reaches 30,000 he is awarded a free game and his score continues to accumulate.

4 IC Board Adjustments

- Note :
- Switch adjustment have to be done after disconnect the power supply.
 - Switches are set as under-lined position when the machine is shipped.

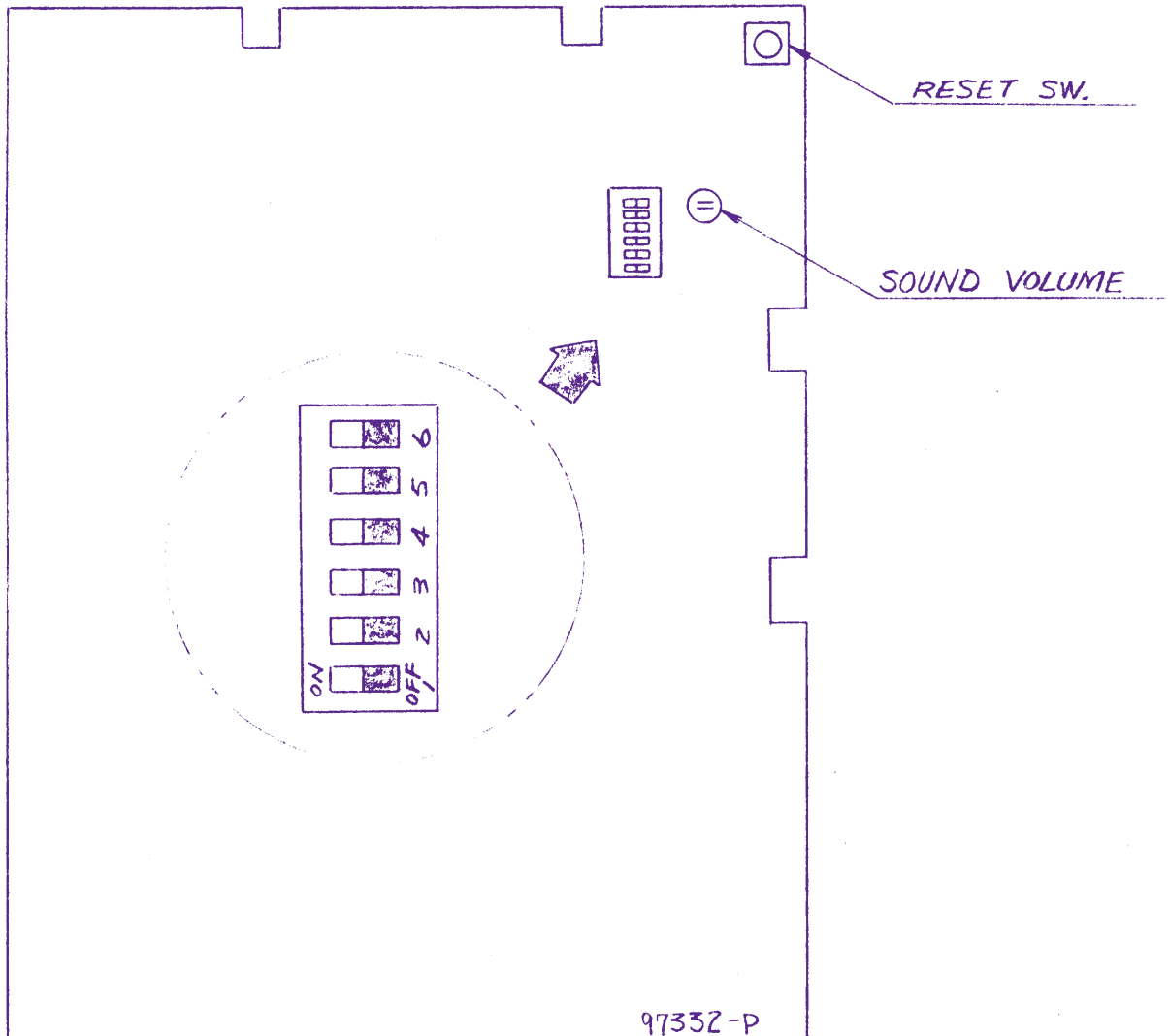

	SW. NO.					
	1	2	3	4	5	6
EXTENDED PLAY						
30000 PT.	<u>OFF</u>					
50000 PT.	<u>ON</u>					
		NOT				
		USE				
COIN CHUTE 1						
1 COIN - 1 PLAY			<u>OFF</u>	<u>OFF</u>		
2 COIN - 1 PLAY			<u>ON</u>	<u>OFF</u>		
3 COIN - 1 PLAY			<u>OFF</u>	<u>ON</u>		
4 COIN - 1 PLAY			<u>ON</u>	<u>ON</u>		
COIN CHUTE 2						
1 COIN - 1 PLAY					<u>OFF</u>	<u>OFF</u>
1 COIN - 2 PLAY					<u>ON</u>	<u>OFF</u>
1 COIN - 3 PLAY					<u>OFF</u>	<u>ON</u>
FREE PLAY					<u>ON</u>	<u>ON</u>

5. TV VOLUME ADJUSTMENTS (1)
(NANAO TYPE)

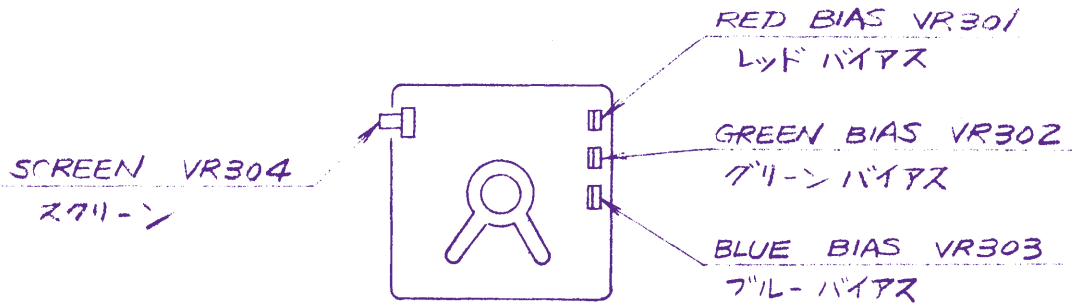

BRIGHT VR104
輝度

V-HOLD VR401 垂直同期

H-HOLD VR501 水平同期

V-POS. VR402 垂直位置

H-POS. VR502 水平位置

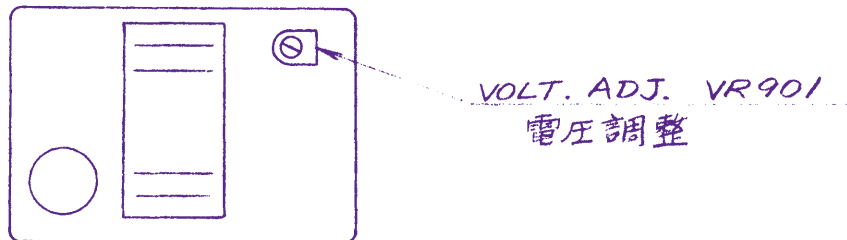
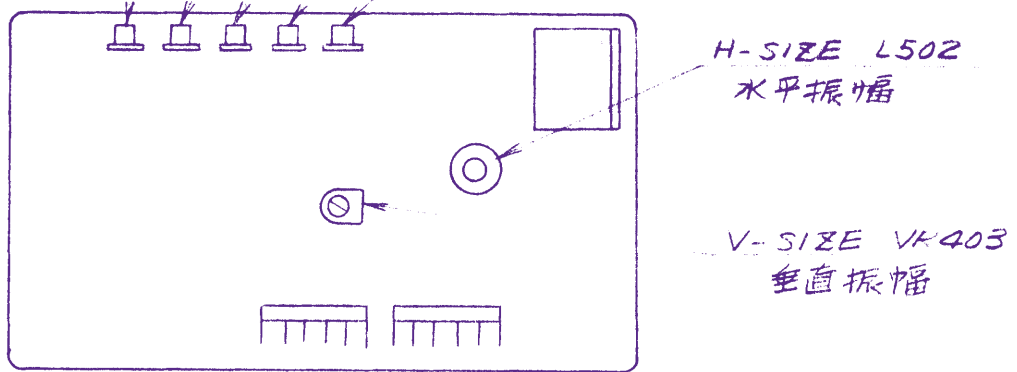

5 TV VOLUME ADJUSTMENTS (2)

(SHARP TYPE)

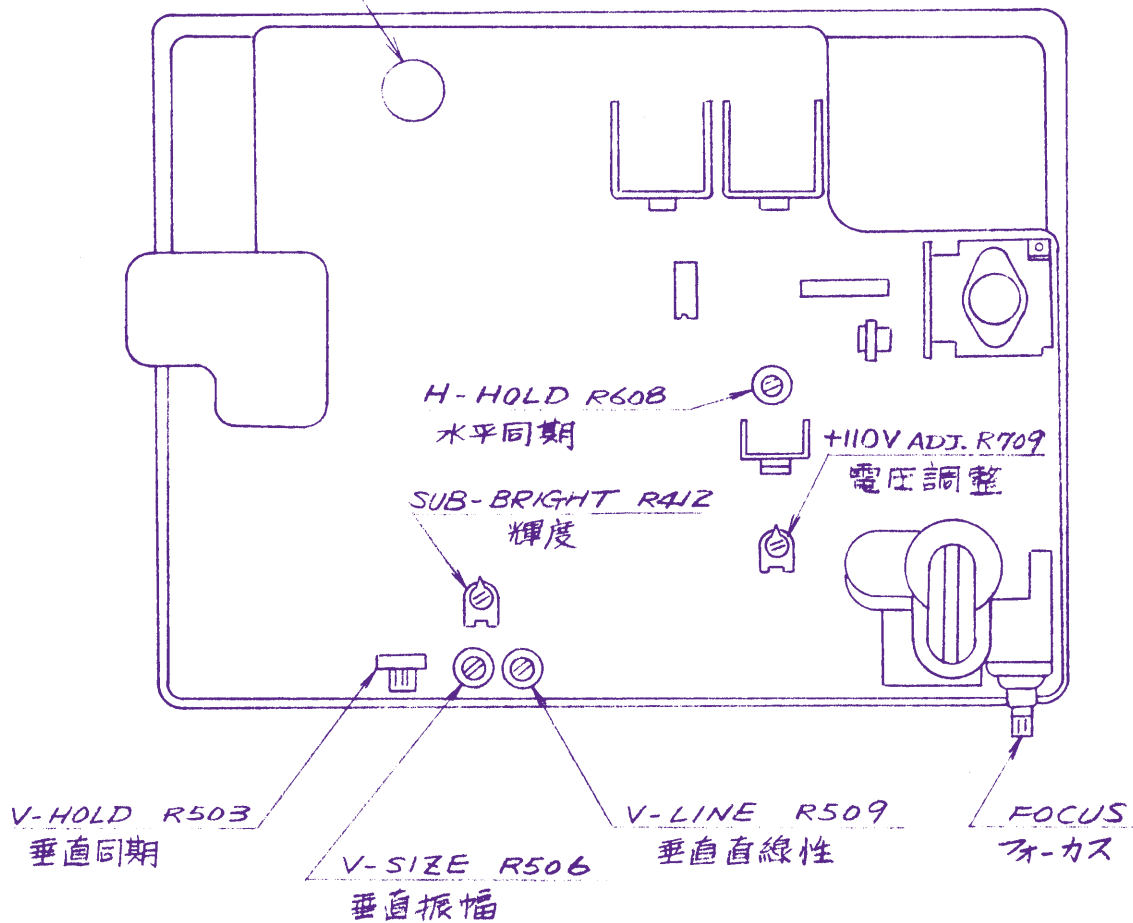
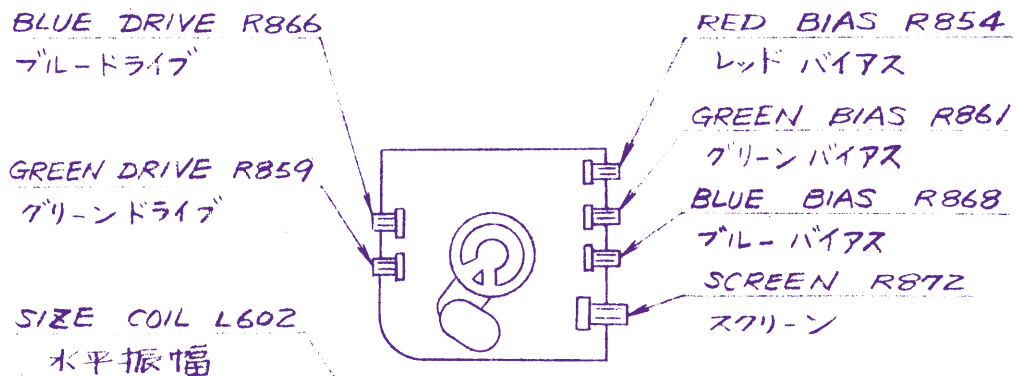

5 Adjustable Controls

A. Brightness

Remember to observe the precautions regarding high voltages when you make any adjustments on this monitor!

Note that before you adjust the brightness, the monitor should have been turned on for at least 5 minutes. Keep the game in the attract or play mode.

Find the black plastic knob near the top center of the Neck Printed-Circuit Board or PCB, sometimes called the picture-tube socket board (see Figure 2). Turn this brightness (or screen voltage) control until you achieve a pleasing level of brightness.

Too high a brightness causes the retrace lines to show. Too low a brightness causes the entire screen to become dark and obscured.

B. Horizontal Hold

Use this adjustment if the picture drifts sideways across the screen. Find the two potentiometers on the right end of the Main PCB (as you face the monitor's screen)—see Figure 3. Turn the coarse or fine pot until the black lines no longer slant downwards or upwards, and you obtain a normal screen image.

C. Vertical Hold

Use this adjustment if the picture drifts straight up or down on the screen. The vertical hold control is the large black knob, third from the left on the Main PCB (as you face the monitor's screen)—see Figure 3.

Turn this control in either direction until the picture no longer drifts straight up or down on screen.

D. Vertical Linearity

Badly adjusted vertical linearity looks like the horizontal raster lines are "squashed" together in certain areas on the screen—usually at the top or bottom. Linearity tends to drift out of adjustment in high-temperature areas after the monitor has been used a long time, or if you replace the picture tube.

The vertical linearity control is located on the Main PCB, fourth from the left as you face the monitor screen. Turn it slowly until all the raster lines are about equally spaced vertically.

not disappear off the edges, which would indicate overscanning.

E. Vertical Height

If the screen image is not large enough or too large vertically, then you can adjust it very easily with this control. Using this control will stretch or compress the image vertically. The vertical height control affects the spacing between the raster lines equally.

F. Horizontal Width

Before using this control, be sure the monitor has been turned on for 5 minutes or more. If the screen image is too wide or narrow, you should use this control to adjust it for proper width.

Set the game for the diagnostic that displays the convergence grid and dots. Locate the horizontal width control on the monitor's Main PCB: it is the small coil at the center rear of this board. **Be sure to use only a non-metal Allen wrench (commonly called a "tweaking" tool) for this adjustment!** Turn this control until the right and left grid lines run along the edges of the screen. The lines should not disappear off the edges, which would indicate overscanning.

G. Focus

This control simply changes the sharpness of the screen image. The focus adjustment is above the right rear of the monitor's Main PCB; the black adjustment knob protrudes from the high-voltage housing/heat sink. Turn this control until you get the optimum screen sharpness possible.

Color Monitor Troubleshooting

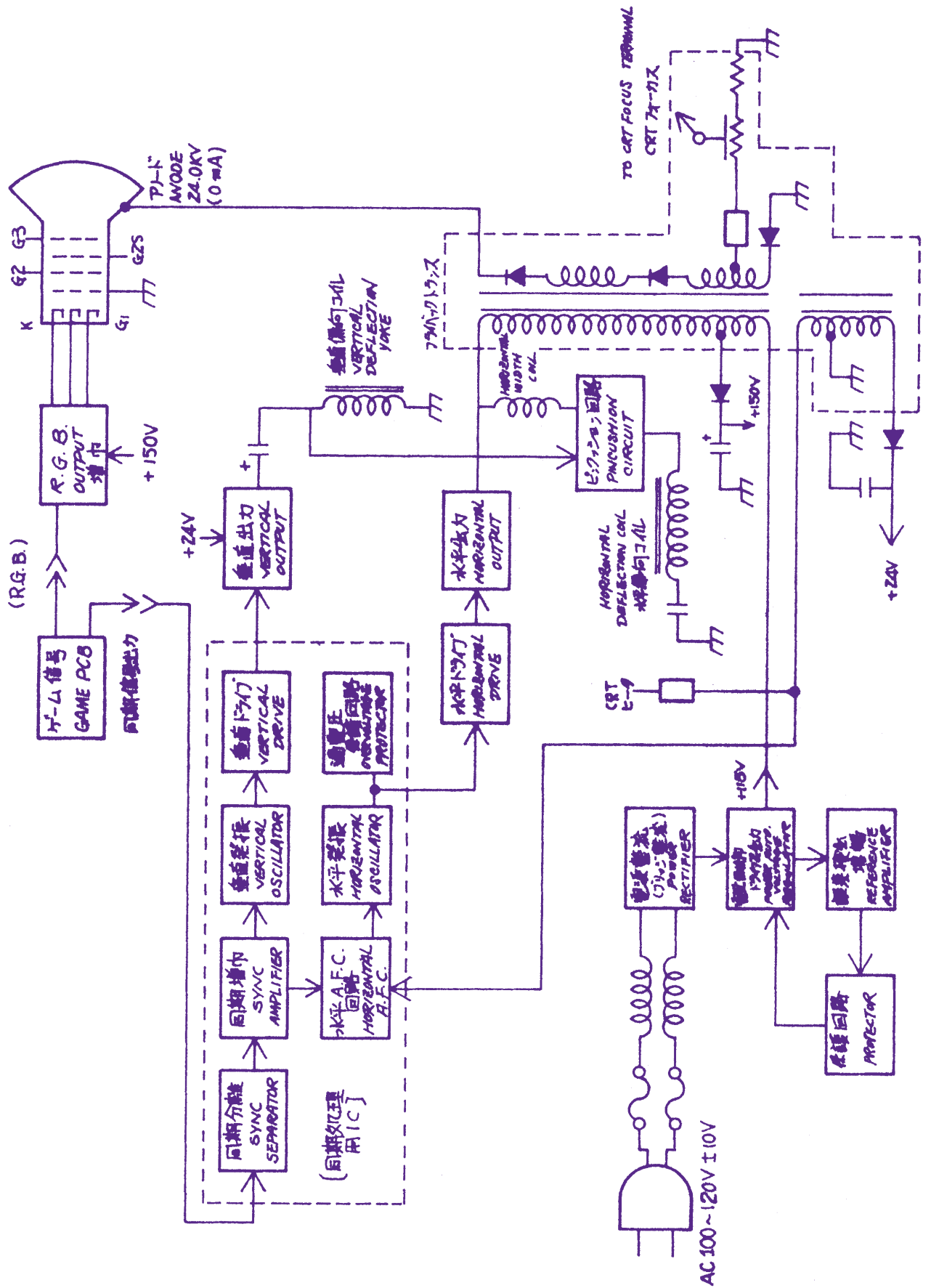

7 Parts Catalog

Cabinet Accessory Assy

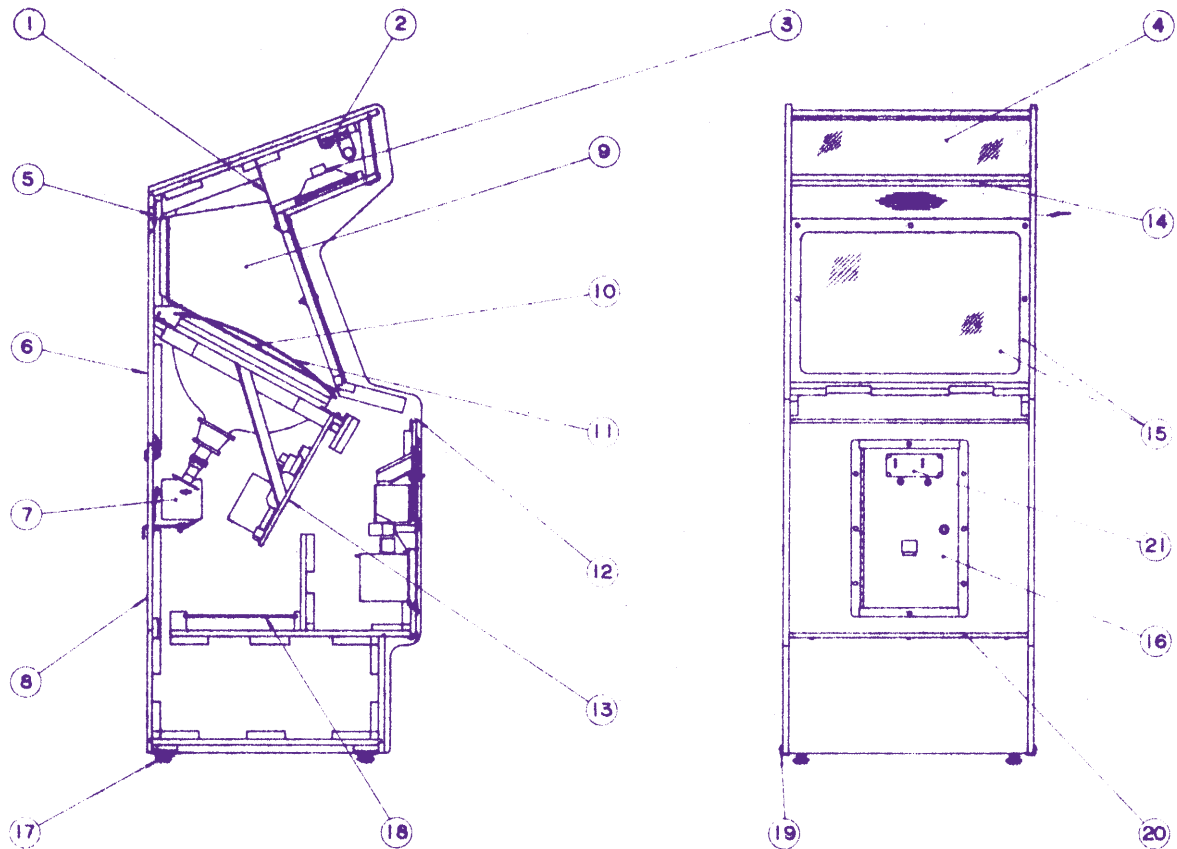

- | | | |
|----|------------|-----------------------------------|
| 1 | MR-1015 | Light Baffle |
| 2 | MR-1004 | FLUORESCENT LIGHT ASSY,15W |
| | S-91058 | Fluorescent Light,Black Light,15W |
| 3 | MR-1009 | Speaker Guard Plate |
| | S-97336 | Speaker,230 x 150mm,8Ω,6W |
| 4 | MR-1012 | Top Panel |
| 5 | MO-1071 | Net Plate |
| 6 | MR-1002 | Back Door,Upper |
| 7 | MR-1019 | JUNCTION BOX ASSY |
| | 97339 | Choke,1μH |
| | S-94972 | Noise Filter,AC250V,2A |
| | S-94339 | Switch,Micro Type |
| | S-95835 | Cable & Plug Assy |
| | S-96774 | Fuse,5A,Time-Lag Type |
| 8 | MR-1003 | Back Door,Lower |
| 9 | MR-1017 | Scenery,Right |
| | MR-1018 | Scenery,Left |
| 10 | MR-1016 | Scenery,Rear |
| 11 | MR-1024 | TV Mask |
| 12 | MR-1005 | Trim,Upper |
| 13 | 97232-P | COLOR DISPLAY ASSY,20TYPE,120V |
| | 97334-P | COLOR DISPLAY ASSY,20TYPE,100V |
| 14 | MR-1007 | Ornament Frame |
| 15 | MR-1013 | Window Panel |
| | MR-1014 | Bezel Frame |
| 16 | MR-1200 | COIN CHUTE DOOR & CASH BOX ASSY |
| | CC-2006 | Coin Chute,Rejector Type,25¢ x 1 |
| 17 | M-163-4(L) | Leg Adjuster |
| 18 | 97332-P | IC BOARD ASSY,MOON CRESTA |
| 19 | MR-1008 | Corner Protector |
| 20 | MR-1006 | Trim,Lower |
| 21 | 80824 | Denomination Plate,25¢ |
| | MO-1245 | Coin Entry Plate,USA 25¢ x 2 |

7 Parts Catalog

Control Panel Assy

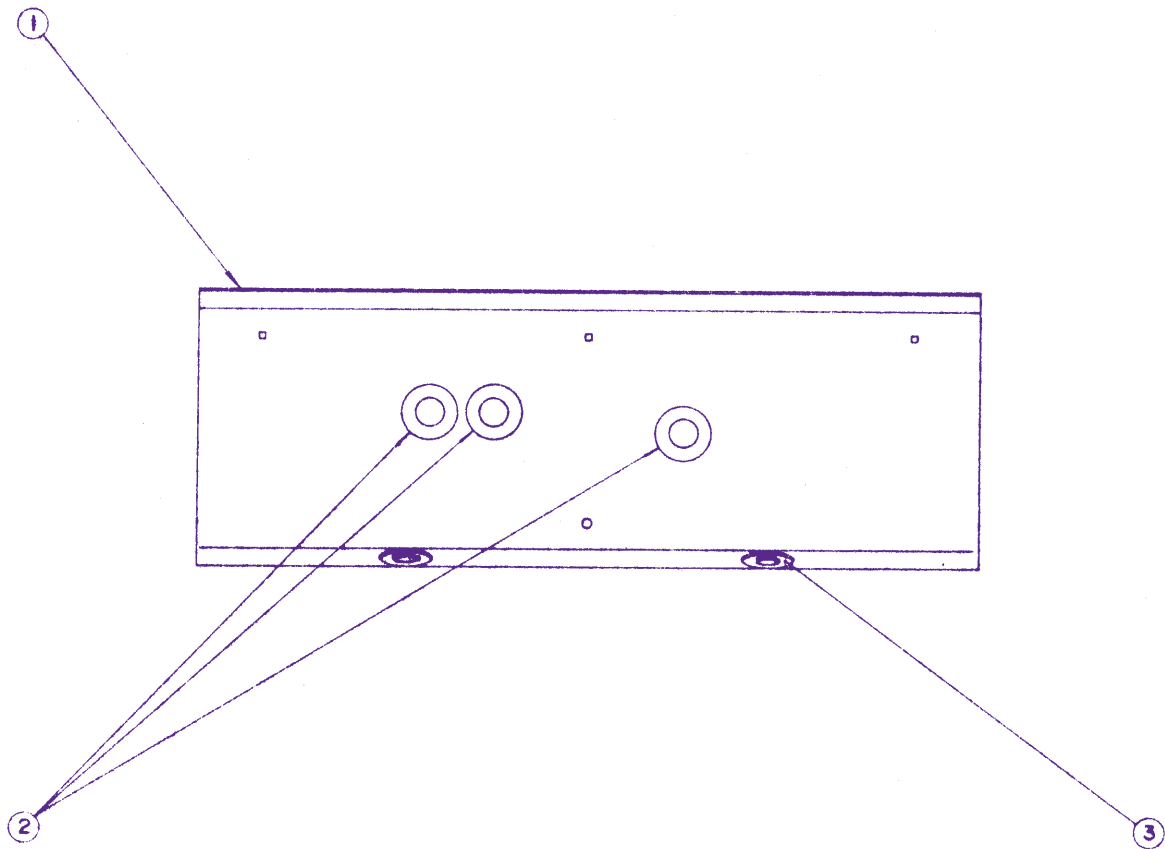

- | | | |
|---|---------|---|
| 1 | MR-2001 | Control Panel Base |
| 2 | MR-2005 | Spacer, Switch Wico |
| | S-97345 | Button Plunger, Yellow (GREMLIN 240-0009) |
| | S-97346 | Assy, Switch Wico (GREMLIN 510-0023) |
| 3 | MR-2005 | Spacer, Switch Wico |
| | S-97344 | Button Plunger, Black (GREMLIN 240-0007) |
| | S-97346 | Assy, Switch Wico (GREMLIN 510-0023) |

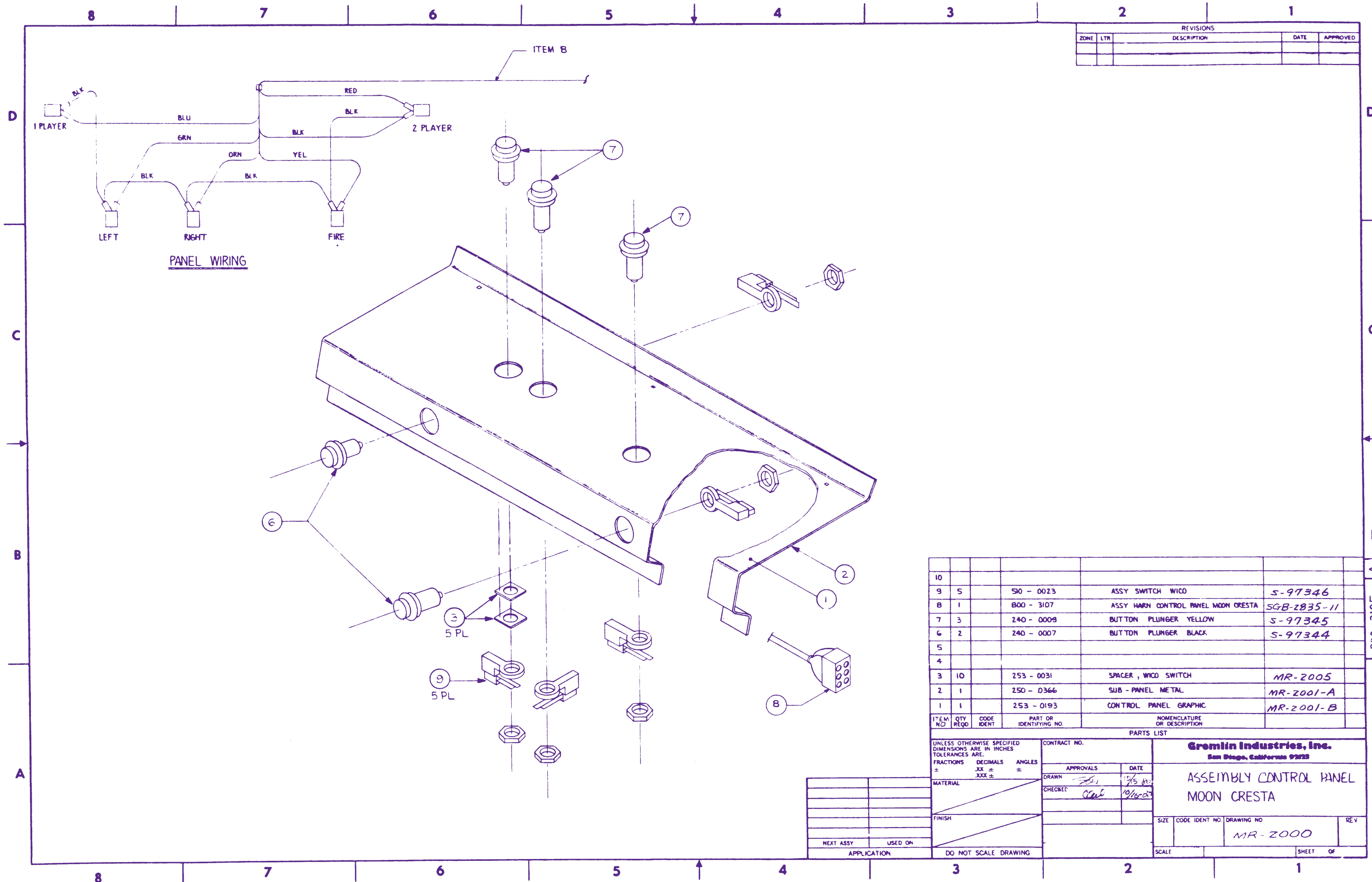

REVISIONS				
ZONE	LTR	DESCRIPTION	DATE	APPROVED

ITEM NO	QTY REQD	CODE IDENT	PART OR IDENTIFYING NO.	NOMENCLATURE OR DESCRIPTION	
10					
9	5		50 - 0023	ASSY SWITCH WICO	S-97346
8	1		800 - 3107	ASSY WARN CONTROL PANEL MOON CRESTA	SGB-2835-11
7	3		240 - 0009	BUTTON PLINGER YELLOW	S-97345
6	2		240 - 0007	BUTTON PLINGER BLACK	S-97344
5					
4					
3	10		253 - 0031	SPACER, WICO SWITCH	MR-2005
2	1		250 - 0366	SUB - PANEL METAL	MR-2001-A
1	1		253 - 0193	CONTROL PANEL GRAPHIC	MR-2001-B

PARTS LIST			
UNLESS OTHERWISE SPECIFIED DIMENSIONS ARE IN INCHES TOLERANCES ARE:		CONTRACT NO.	
FRACTIONS ±	DECIMALS .XX ±	ANGLES ±	
	.XXX ±		
MATERIAL	FINISH	APPROVALS	DATE
		DRAWN	12/5/80
		CHECKED	10/16/80
NEXT ASSY USED ON APPLICATION		DO NOT SCALE DRAWING	
		Gremlin Industries, Inc. San Diego, California 92123 ASSEMBLY CONTROL PANEL MOON CRESTA	
SIZE	CODE IDENT NO.	DRAWING NO.	REV
		MR-2000	
SCALE	SHEET		OF

7 Parts Catalog

Power Supply Assy

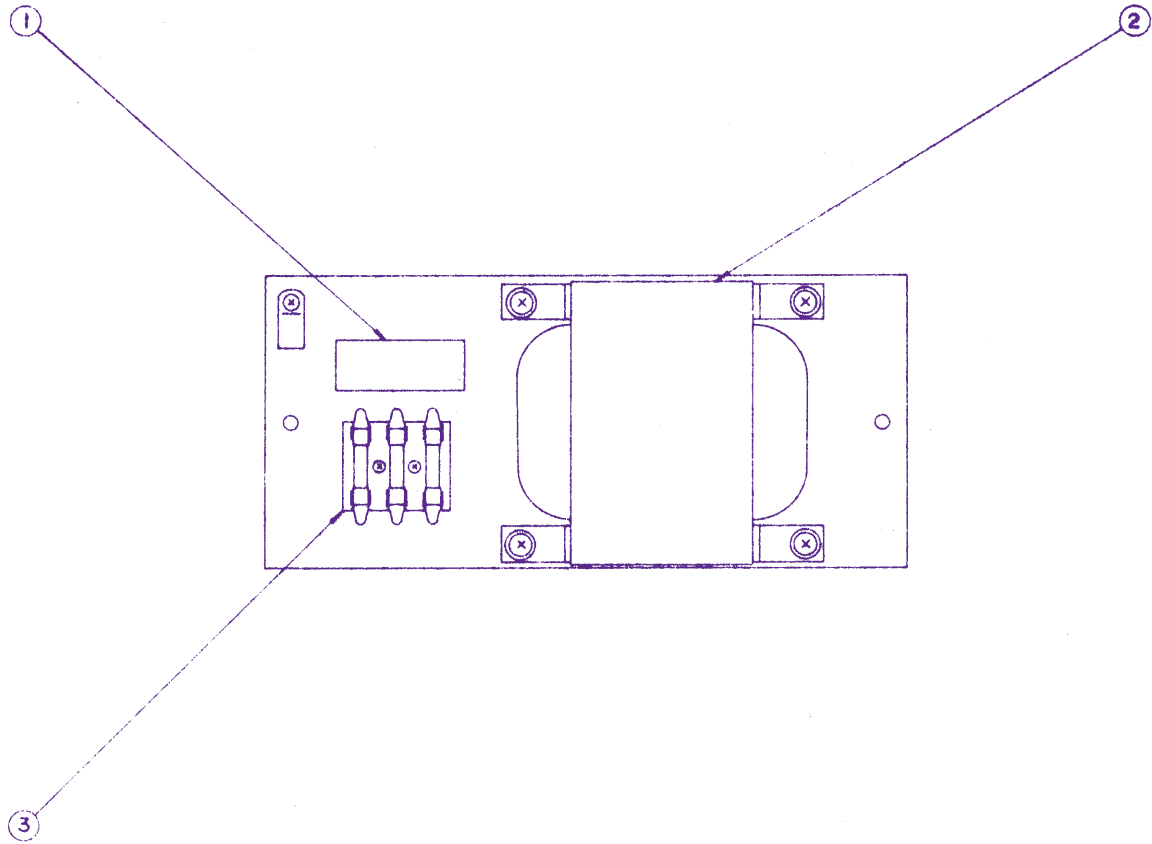

- | | | |
|---|---------|------------------------------|
| 1 | 83334 | Fuse Instructions |
| 2 | 97313 | Power Transformer, 100V-240V |
| 3 | S-93003 | Fuse Holder, 3P |
| | S-96774 | Fuse, 5A, Time-Lag Type |

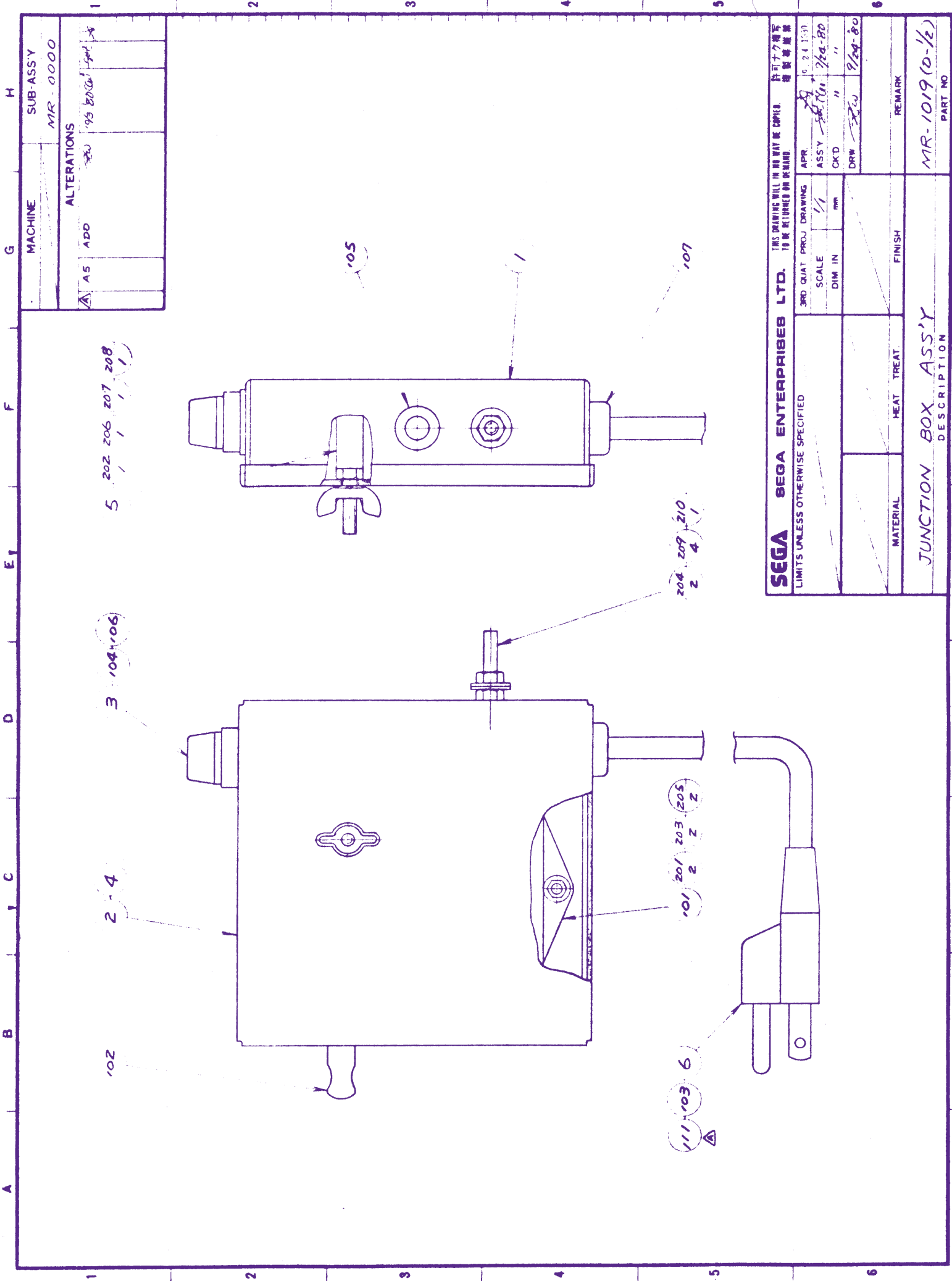

MACHINE		SUB-ASSY	
MR-0000		MR-0000	
ALTERATIONS			
A	AS	ADD	195 B2000 1/2" dia

5 202 206 207 208

3 104 106

2 4

102

204 209 210
2 4 1

101 201 203 205
2 2 2 2

111 103 6

SEGA BEGA ENTERPRISES LTD.		THIS DRAWING WILL IN NO WAY BE COPIED, REPRODUCED OR TRANSMITTED IN ANY FORM OR BY ANY MEANS, WITHOUT THE WRITTEN PERMISSION OF SEGA BEGA ENTERPRISES LTD.	
LIMITS UNLESS OTHERWISE SPECIFIED	3RD QUAT PROJ DRAWING	APR 9 24 1980	許可なく複製 複製禁止
	SCALE 1/1	ASSY 5/11/80	
	DIM IN mm	CKD "	
		DRW 9/24-80	
MATERIAL	HEAT TREAT.	FINISH	REMARK
JUNCTION BOX ASS'Y			MR-1019 (D-1/2)
DESCRIPTION			PART NO

. MACHINE		SUB-ASS'Y					
		MR-1000					
ALTERATIONS							
△	CHANGED DESCRIPTION						
△	ADD	220	9/16-50 UNF	940	27		
△	ADD						
△	WAS	111-630	220	9/16-50 UNF	940	27	

210	111-937	1	M. SCREW, P.H. PHILL., BRASS, ISO				M4x25
209	144-269	4	FLAT WASHER, SPECIAL, BRASS				4-12x1
208	133-112	1	WING NUT, ISO				M4
207	133-089	1	HEX. NUT, ISO				M4
206	144-076	1	SPRING WASHER				M4 (*2)
205	144-057	2	FLAT WASHER				M3
204	133-133	2	HEX. NUT, BRASS, ISO				M4
203	133-088	2	HEX. NUT, ISO				M3
202	111-678	1	M. SCREW, F.H. PHILL., ISO				M4x15
201	111-854	2	M. SCREW, F.H. PHILL., ISO				M3x10
111	S-92398	50 _{mm}	THERMO-SHRINK TUBE, "HISHILITE" TRANSPARENT, 17.5mm				
110	S-96564	2	TERMINAL LUG, ROUND I. D. 5 (AMP 170011-2)				
109	S-91978-1	*3	SOCKET ELEMENT (AMP 170147-1)				
108	S-93542-1	1	SOCKET, 3P, BROWN (AMP 1-480304-1)				
107	S-96148	1	BUSHING, STRAIN RELIEF, 8.3 (HEYCO SR-6N-4)				
106	S-96774	*1	FUSE, 5A, TIME-LAG TYPE, 6.35" x 31.75mm (NAGASAWA 61T5)				
105	S-92310	1	RUBBER GROMMET, 7" x 10" x 4.5 (TAKIGEN 19-79-C)				
104	S-90207	1	FUSE HOLDER, W/SCREW CAP (SATO F-4000) (UL STANDARD ROUND TYPE)				
103	S-95835	1	CABLE & PLUG ASSY, W/EARTH, 0.16x41x3, L=3m (CHERRY 579-30A)				
102	S-94339	1	SWITCH, MICRO TYPE, DEPT. CHEAT INTER LOCK TYPE				
101	S-94972	1	NOISE FILTER, AC 250V, 2A (TDK Z9B 220Z-01)				
6	97339	1	CHOKE, 1MH				
5	FL-3237	1	SPACER TUBE, 26				
4	81319	1	STICKER, 120V				
3	80426	1	STICKER, 5 AMPERE				
2	MR-1021	1	COVER				
1	MR-1020	1	JUNCTION BOX				

D.NO	POS.	PART NO.	Q/U	DESCRIPTION	NOTE

APR. 9. 22 1980.
DRAFT. 9/11/80

JUNCTION BOX ASS'Y	PARTS LIST:	MR-1019(D-7/2)
DESCRIPTION		PART NO.

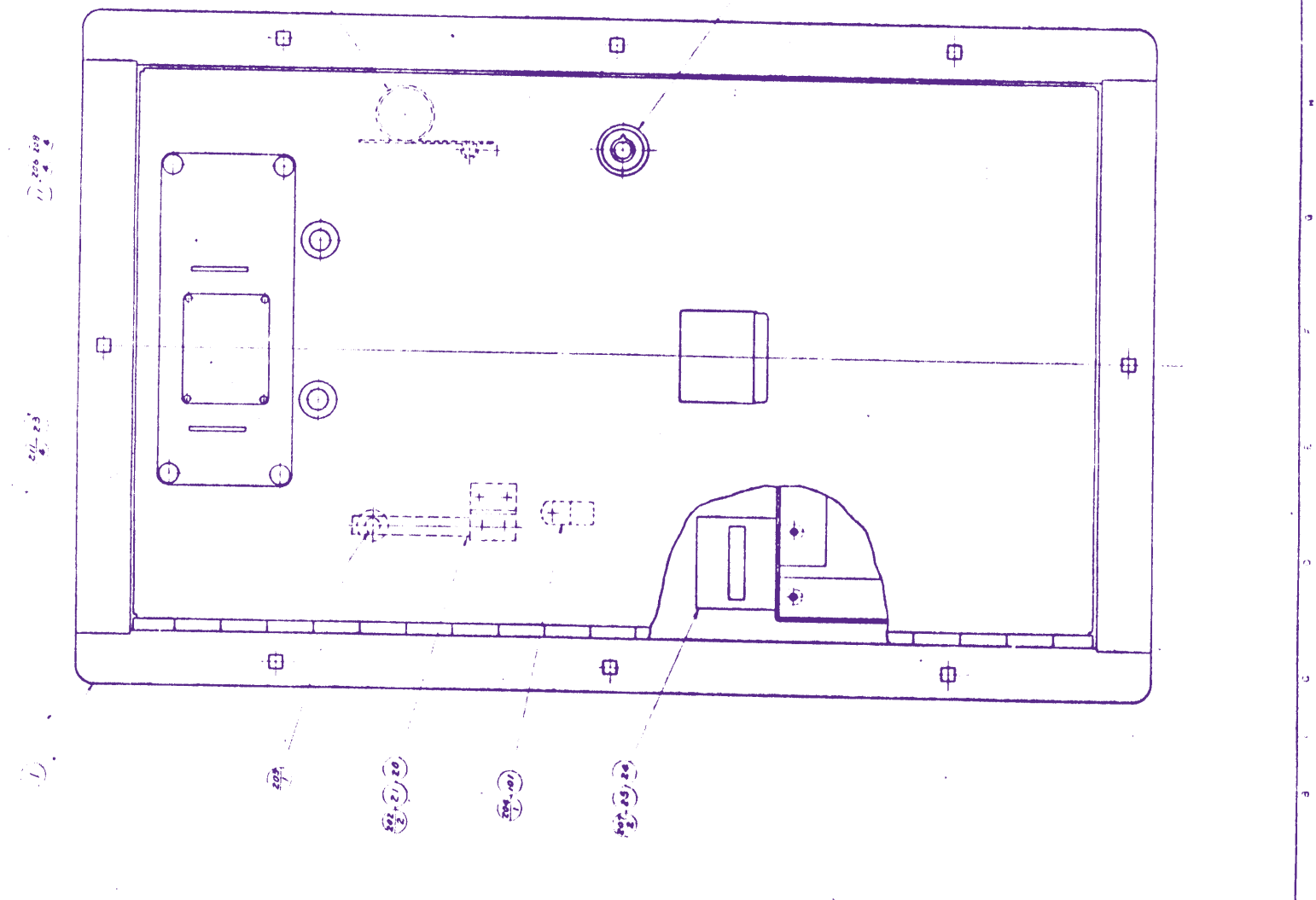
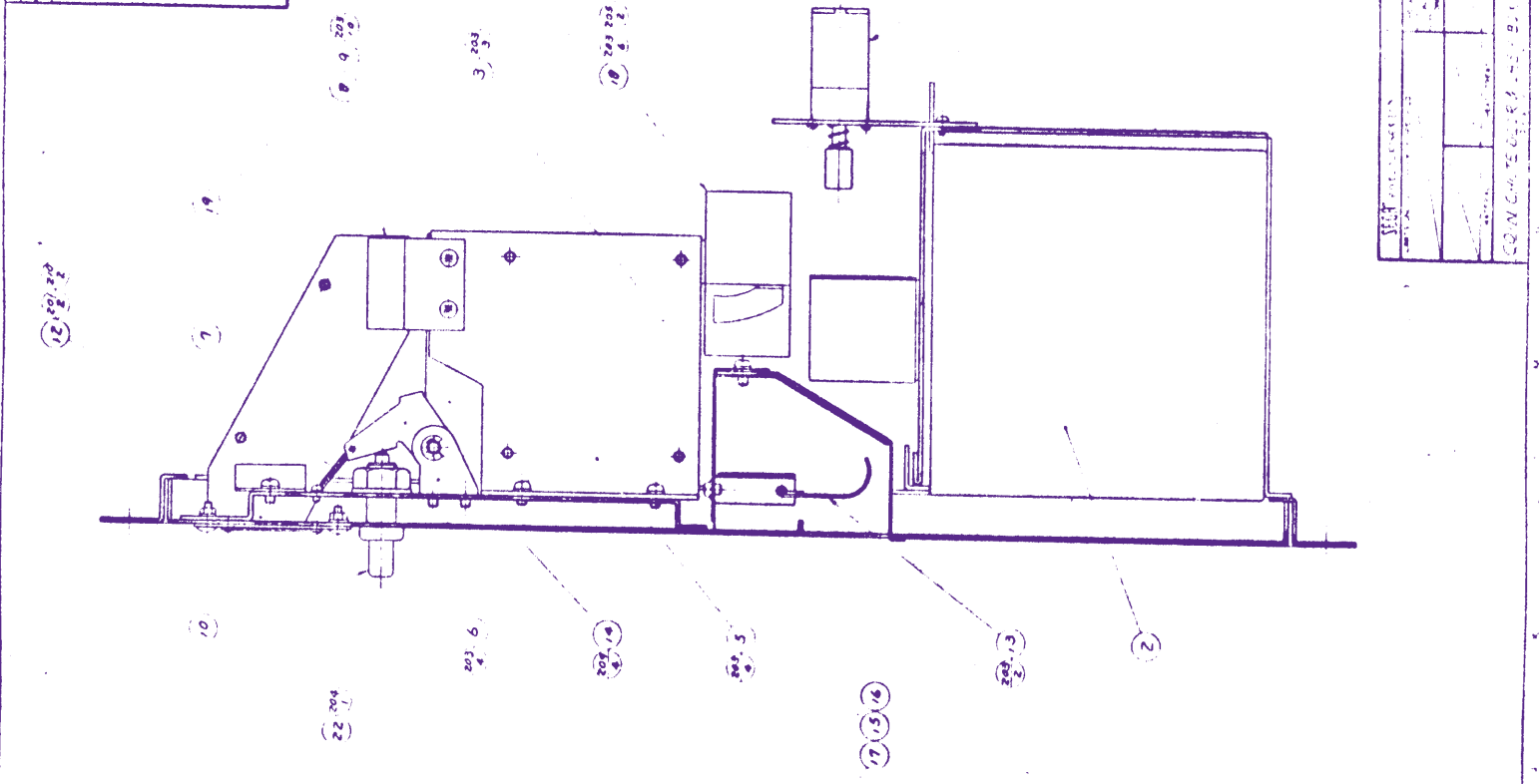

DATE	BY	CHECKED	APPROVED
CONSTRUCTION OF THE BUILDING			

MACHINE	SUB-ASSY				
		MR-1000			
ALTERATIONS					

101	S-90181	1	CLAMP, CORD, PLASTIC, 8mm, I.D.
25	80931	1	STICKER, COIN METER
24	90303E-5-P	1	MAGNET COUNTER, 6 DIGITS, DC 5V
23	80824	1	DENOMINATION PLATE, 25¢
22	30060	1	KEY HOLDER
21	SK-1057	1	TILT SWITCH ASS'Y, IM.
20	SK-1042	1	SWITCH BRACKET
19	CC-2006	2	COIN CHUTE, REJECTOR TYPE, 25¢ x 1
18	CC-2050	2	COIN CHUTE BRACKET ASS'Y
17	LS-1064	1	ACE CYLINDER LOCK, L.S. TYPE
16	PB-1022	1	LOCK TONGUE
15	SW-1108	1	SPACER RING
14	SH-1007	2	SHAFT
13	MF-1010	1	FLAP DOOR ASS'Y
12	OL-3018	2	EXTENSION SPRING
11	MO-1245	1	COIN ENTRY PLATE, U.S.A. 25¢ x 2
10	MP-1017	2	REJECT BUTTON ASS'Y
9	DH-1046	2	COIN ENTRY BRACKET, B
8	DH-1045	2	COIN ENTRY BRACKET, A
7	DH-1044	2	REJECT LEVER
6	DH-1043	2	REJECT LEVER BRACKET
5	DH-1042X	2	COIN CHUTE BRACKET
4	MR-1204	1	ADJUSTMENT UNIT
3	MR-1203	1	COVER
2	MR-1202	1	CASH BOX
1	MR-1201	1	COIN CHUTE DOOR

D NO	POS.	PART NO	Q/U	DESCRIPTION	NOTE
					APR. <i>[Signature]</i> 9.23.1980
					DRAFT. <i>[Signature]</i> 9/2/80
COIN CHUTE DOOR & CASH BOX ASS'Y				PARTS LIST	MR-1200 (D-3/3)
DESCRIPTION					PART NO

MACHINE	SUB-ASSY
	MR-1200
ALTERATIONS	

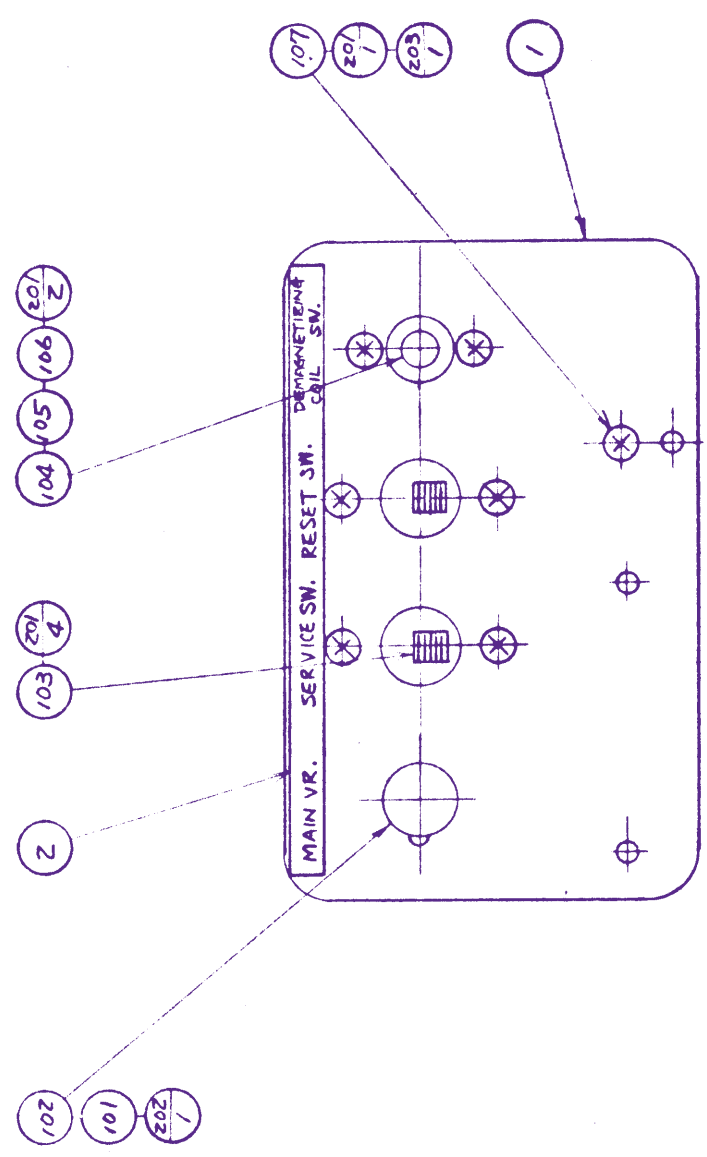

SEGA BEGA ENTERPRISES LTD.		THIS DRAWING WILL IN NO WAY BE COPIED. 此圖不可複製	
LIMITS UNLESS OTHERWISE SPECIFIED		3RD QUAT PROJ DRAWING	
SCALE	1/1	APR	9/1/80
DIM IN	mm	ASSY	MR-1200
		CK'D	"
		DRW	CAI 9/18-80
MATERIAL	HEAT TREAT	FINISH	
ADJUSTMENT UNIT		REMARK	
DESCRIPTION		MR-1204 (D-1/2)	
		PART NO.	

MACHINE	SUB ASS'Y
	MR-1200
ALTERATIONS	
WASS-92040-1 NAS Q/U, 110-2, 111-12	9/29-80 CA-50 *

203	133-088	1	HEX. NUT, ISO	M3	
202	111-991	1	SET SCREW, HEX. SOCKET, CUP POINT, ISO	M2.6x5	
201	111-892	7	M. SCREW, P.H. PHILL., ISO, W/S. WASHER	M3x8	
112	S-93687-1	1	SOCKET, 2P, FREE HANGING TYPE, ORANGE (AMP 1-170923-3)		
111	S-91978-2	x14	PIN ELEMENT (AMP 61116-1)		
110	S-91978-1	*2	SOCKET ELEMENT (AMP 170147-1)		
109	S-91980-2	1	PLUG, 12P, NATURAL COLOR (AMP 1-480278-0)		
108	S-92040-2	1	PLUG, 2P, FREE HANGING TYPE, RED (AMP 1-170924-2)		
107	S-92896	1	TERMINAL PLATE, 12P (IZAWA NO.8) (TV 97232-P) 使用 (MATSUSHITA DENKI ECG-30186A)		
106	S-95657	1	C & R COMBINATION ELEMENT, 0.1MF & 120Ω		
105	S-96397	1	PUSH BUTTON SWITCH, IM. W/O BUTTON (MATSUSHITA 9932R)		
104	S-96400	1	PUSH BUTTON, IVORY, 8P (TOKO 470-010-01-10)		
103	S-93640	2	SWITCH, SLIDE TYPE, 6P (SHONA MUSEN SJ-0275-02)		
102	S-96416	1	KNOB, METAL (SATO K-29)		
101	S-96417	1	RHEOSTAT, 100Ω, 10W (NOBLE RPF 10)		
Z C1	83335	1	STICKER, SWITCH INSTRUCTIONS		
1 F3	MR-1205	1	SWITCH BRACKET		
D.NO.	POS.	PART NO.	Q/U	DESCRIPTION	NOTE

APR. 9. 22 1980
DRAFT. 9/10-80

ADJUSTMENT UNIT	(PARTS LIST)	MR-1204 (D-3/2)
DESCRIPTION		PART NO.

WIRING DIAGRAM

REVISIONS				
ZONE	LTR	DESCRIPTION	DATE	APPROVED

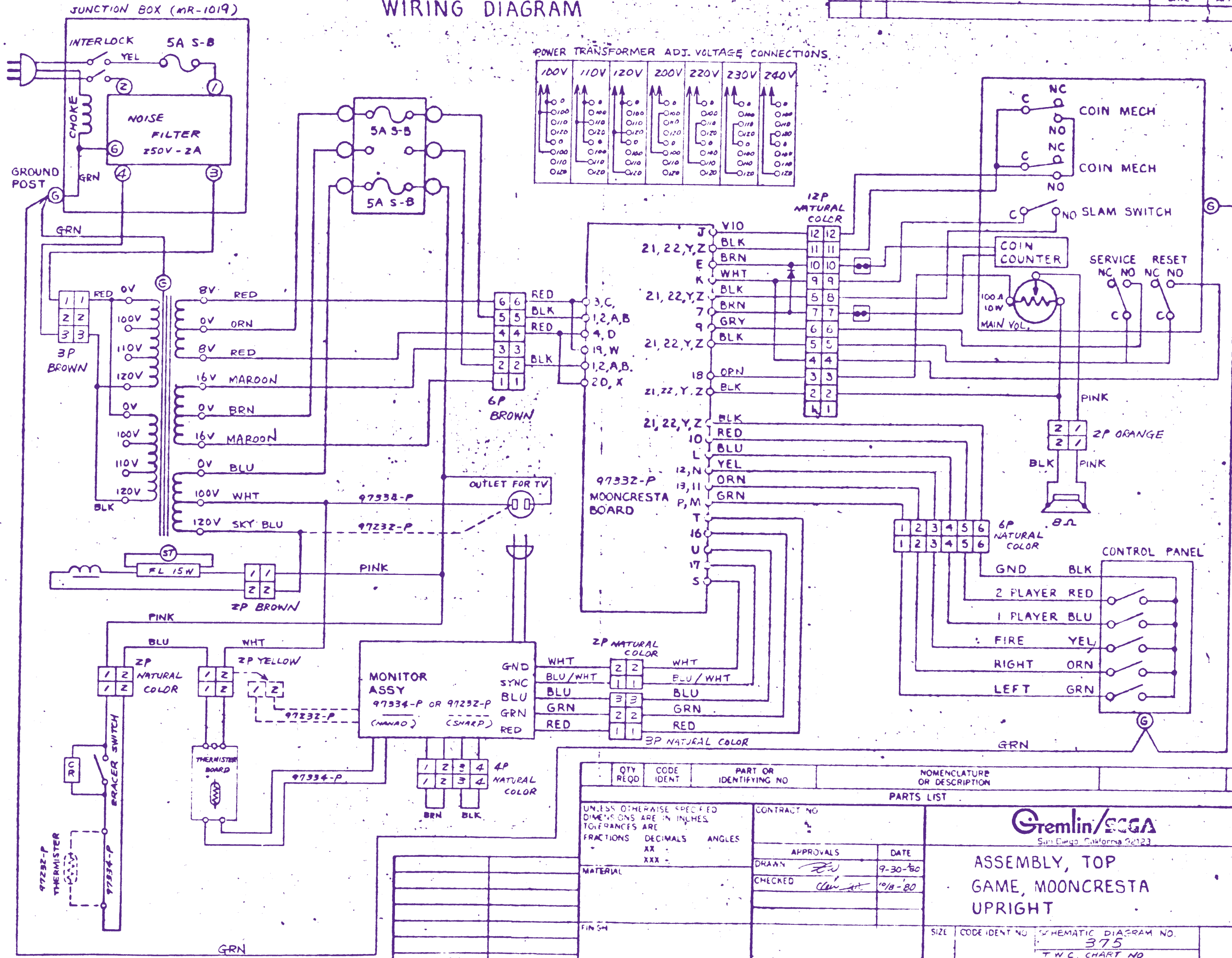

POWER TRANSFORMER ADJ. VOLTAGE CONNECTIONS

100V	110V	120V	200V	220V	230V	240V
0-100	0-110	0-120	0-100	0-110	0-120	0-100
0-110	0-120	0-100	0-110	0-120	0-100	0-110
0-120	0-100	0-110	0-120	0-100	0-110	0-120
0-100	0-110	0-120	0-100	0-110	0-120	0-100
0-110	0-120	0-100	0-110	0-120	0-100	0-110
0-120	0-100	0-110	0-120	0-100	0-110	0-120

QTY REQD	CODE IDENT	PART OR IDENTIFYING NO	NOMENCLATURE OR DESCRIPTION
PARTS LIST			
UNLESS OTHERWISE SPECIFIED DIMENSIONS ARE IN INCHES TOLERANCES ARE FRACTIONS DECIMALS ANGLES XX .XXX -		CONTRACT NO.	
MATERIAL		APPROVALS	DATE
FINISH		DRAWN <i>[Signature]</i>	9-30-80
NEXT ASSY		CHECKED <i>[Signature]</i>	10/8-80
USED ON		ASSEMBLY, TOP GAME, MOONCRESTA UPRIGHT	
APPLICATION			
DO NOT SCALE DRAWING		SIZE	CODE IDENT NO
		SCHEMATIC DIAGRAM NO. 375	
		T.W.C. CHART NO. SGB-2835	
		SCALE NONE	SHEET OF

700-0030 | A

MAIN I.C. BOARD SHT 1

REVISIONS			
ZONE	LTR	DESCRIPTION	DATE

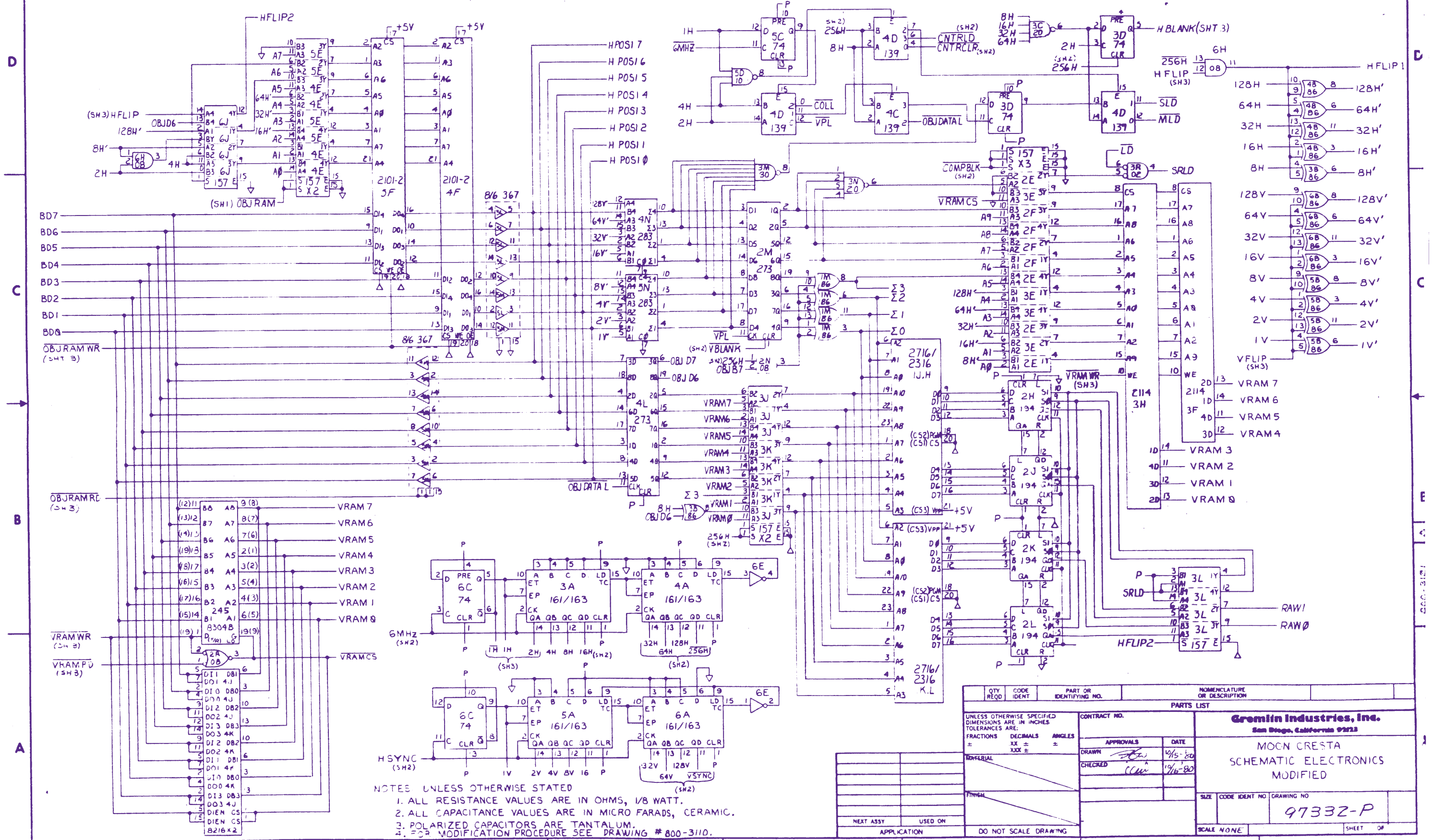

- NOTES UNLESS OTHERWISE STATED
1. ALL RESISTANCE VALUES ARE IN OHMS, 1/8 WATT.
 2. ALL CAPACITANCE VALUES ARE IN MICRO FARADS, CERAMIC.
 3. POLARIZED CAPACITORS ARE TANTALUM.
 4. FOR MODIFICATION PROCEDURE SEE DRAWING # 800-3110.

QTY REQD		CODE IDENT	PART OR IDENTIFYING NO.	NOMENCLATURE OR DESCRIPTION																																					
PARTS LIST																																									
UNLESS OTHERWISE SPECIFIED DIMENSIONS ARE IN INCHES. TOLERANCES ARE:				<table border="1" style="width: 100%;"> <tr> <td colspan="2">CONTRACT NO.</td> <td colspan="2">DATE</td> </tr> <tr> <td>DRAWN</td> <td> </td> <td> </td> <td> </td> </tr> <tr> <td>CHECKED</td> <td> </td> <td> </td> <td> </td> </tr> </table>		CONTRACT NO.		DATE		DRAWN				CHECKED																											
CONTRACT NO.		DATE																																							
DRAWN																																									
CHECKED																																									
FRACTIONS	DECIMALS	ANGLES		<table border="1" style="width: 100%;"> <tr> <td colspan="2" style="text-align: center;">Gremlin Industries, Inc.</td> </tr> <tr> <td colspan="2" style="text-align: center;">San Diego, California 92123</td> </tr> <tr> <td colspan="2" style="text-align: center;">MOON CRESTA</td> </tr> <tr> <td colspan="2" style="text-align: center;">SCHEMATIC ELECTRONICS</td> </tr> <tr> <td colspan="2" style="text-align: center;">MODIFIED</td> </tr> <tr> <td>±</td> <td>XX ±</td> <td colspan="2">±</td> <td colspan="2" rowspan="2"> <table border="1" style="width: 100%;"> <tr> <td>SIZE</td> <td>CODE IDENT NO.</td> <td>DRAWING NO.</td> </tr> <tr> <td> </td> <td> </td> <td style="text-align: center;">97332-P</td> </tr> </table> </td> </tr> <tr> <td>±</td> <td>XXX ±</td> <td colspan="2">±</td> <td colspan="2"> <table border="1" style="width: 100%;"> <tr> <td>SCALE</td> <td>NONE</td> <td>SHEET</td> <td>OF</td> </tr> <tr> <td> </td> <td> </td> <td> </td> <td> </td> </tr> </table> </td> </tr> </table>		Gremlin Industries, Inc.		San Diego, California 92123		MOON CRESTA		SCHEMATIC ELECTRONICS		MODIFIED		±	XX ±	±		<table border="1" style="width: 100%;"> <tr> <td>SIZE</td> <td>CODE IDENT NO.</td> <td>DRAWING NO.</td> </tr> <tr> <td> </td> <td> </td> <td style="text-align: center;">97332-P</td> </tr> </table>		SIZE	CODE IDENT NO.	DRAWING NO.			97332-P	±	XXX ±	±		<table border="1" style="width: 100%;"> <tr> <td>SCALE</td> <td>NONE</td> <td>SHEET</td> <td>OF</td> </tr> <tr> <td> </td> <td> </td> <td> </td> <td> </td> </tr> </table>		SCALE	NONE	SHEET	OF				
Gremlin Industries, Inc.																																									
San Diego, California 92123																																									
MOON CRESTA																																									
SCHEMATIC ELECTRONICS																																									
MODIFIED																																									
±	XX ±	±		<table border="1" style="width: 100%;"> <tr> <td>SIZE</td> <td>CODE IDENT NO.</td> <td>DRAWING NO.</td> </tr> <tr> <td> </td> <td> </td> <td style="text-align: center;">97332-P</td> </tr> </table>		SIZE	CODE IDENT NO.	DRAWING NO.			97332-P																														
SIZE	CODE IDENT NO.	DRAWING NO.																																							
		97332-P																																							
±	XXX ±	±		<table border="1" style="width: 100%;"> <tr> <td>SCALE</td> <td>NONE</td> <td>SHEET</td> <td>OF</td> </tr> <tr> <td> </td> <td> </td> <td> </td> <td> </td> </tr> </table>		SCALE	NONE	SHEET	OF																																
SCALE	NONE	SHEET	OF																																						

MAIN I.C. BOARD SHT 2

REVISIONS				
ZONE	LTR	DESCRIPTION	DATE	APPROVED

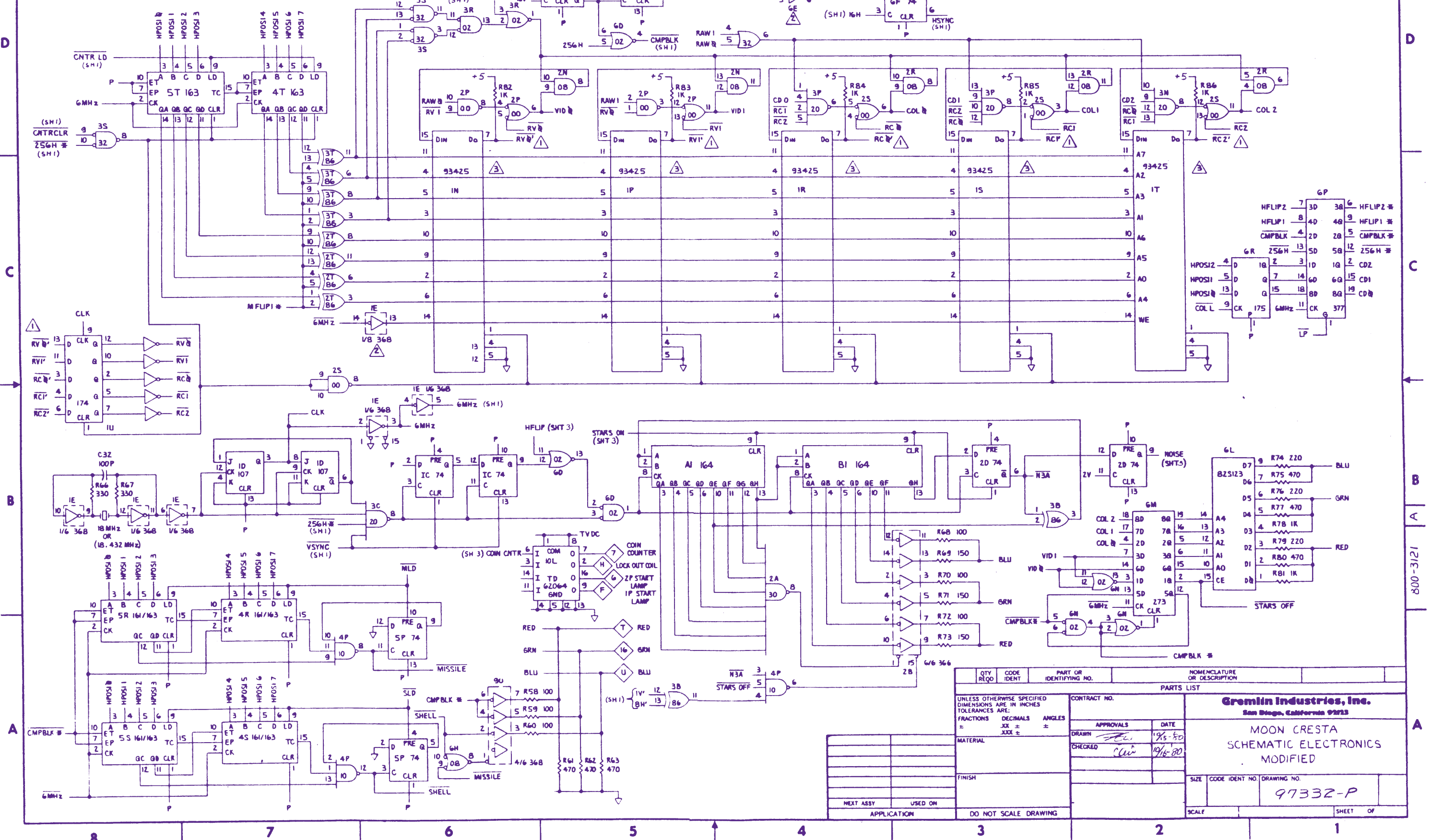

QTY	CODE	PART OR IDENTIFYING NO.	NOMENCLATURE OR DESCRIPTION

PARTS LIST		
UNLESS OTHERWISE SPECIFIED DIMENSIONS ARE IN INCHES TOLERANCES ARE:	CONTRACT NO.	
FRACTIONS ±	DECIMALS ±	ANGLES ±
XXX ±	XXX ±	XXX ±
MATERIAL	APPROVALS	DATE
FINISH	DRAWN	12-50
	CHECKED	10/1-80

MOON CRESTA		SCHEMATIC ELECTRONICS	
MODIFIED		DRAWING NO.	
		97332-P	
SCALE		SHEET	

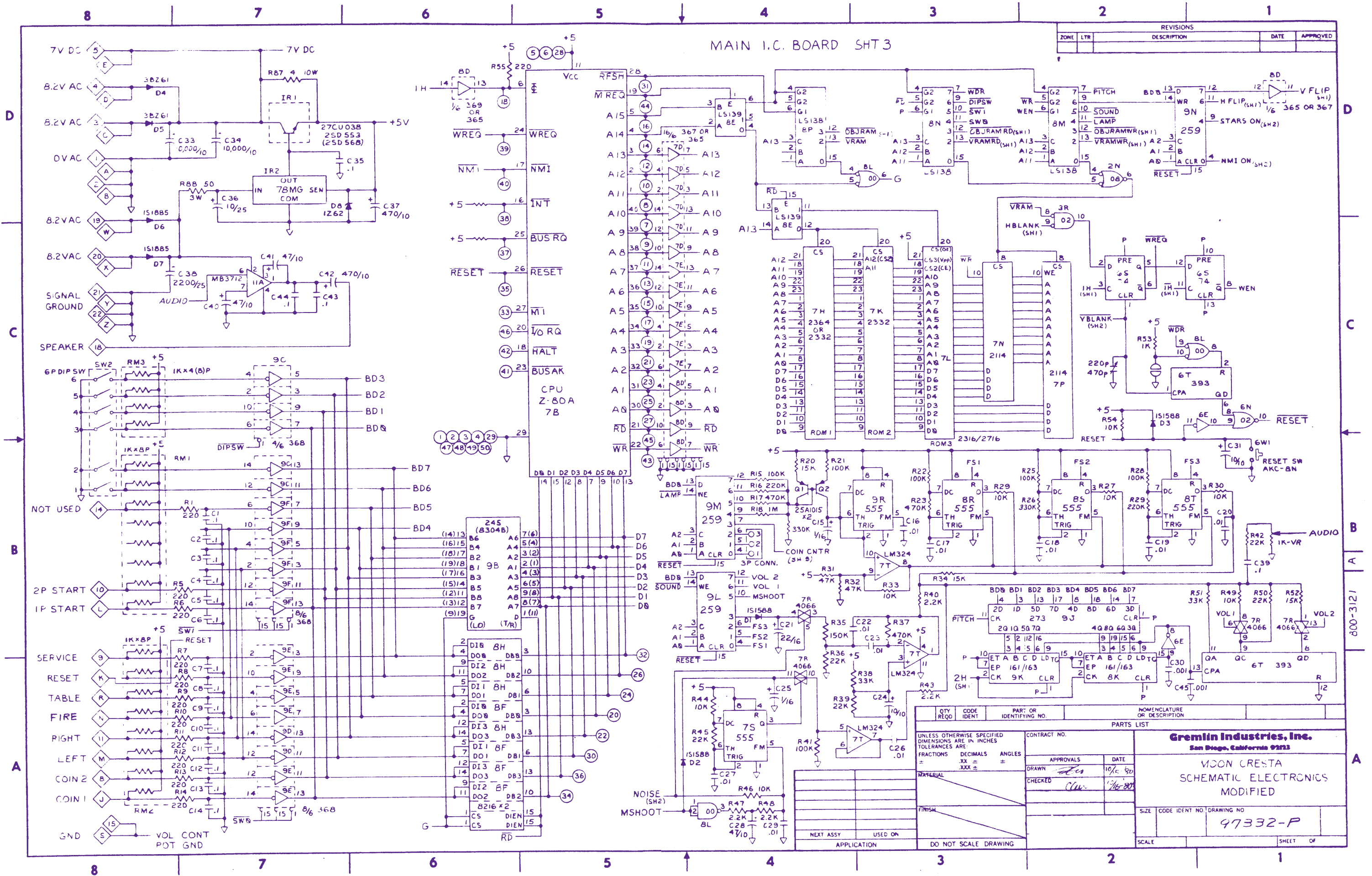

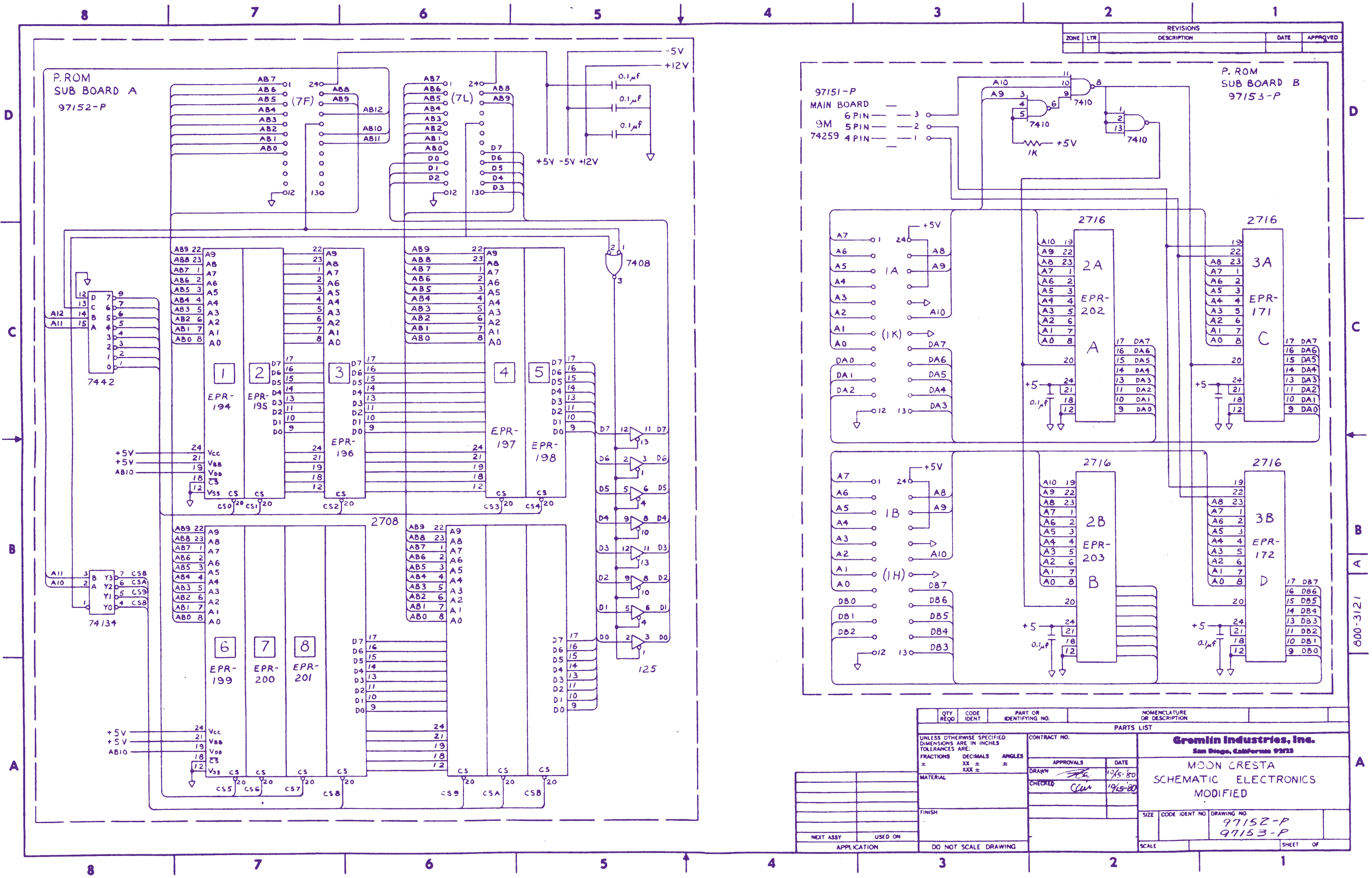

REVISIONS				
ZONE	LTR	DESCRIPTION	DATE	APPROVED

QTY	CODE	PART OR	NOMENCLATURE
REQD	IDENT	IDENTIFYING NO.	OR DESCRIPTION
PARTS LIST			
UNLESS OTHERWISE SPECIFIED DIMENSIONS ARE IN INCHES TOLERANCES ARE:		CONTRACT NO.	
FRACTIONS	DECIMALS	ANGLES	Gromin Industries, Inc. San Diego, California 92123 MOON CRESTA SCHEMATIC ELECTRONICS MODIFIED
±	.XX ±	±	
MATERIAL	APPROVALS	DATE	SIZE
FINISH	CHECKED	19/5-80	CODE IDENT NO
NEXT ASSY	USED ON	19/5-80	DRAWING NO
APPLICATION	DO NOT SCALE DRAWING	SCALE	97152-P
			97153-P
			SHEET OF

REVISIONS				
ZONE	LTR	DESCRIPTION	DATE	APPROVED

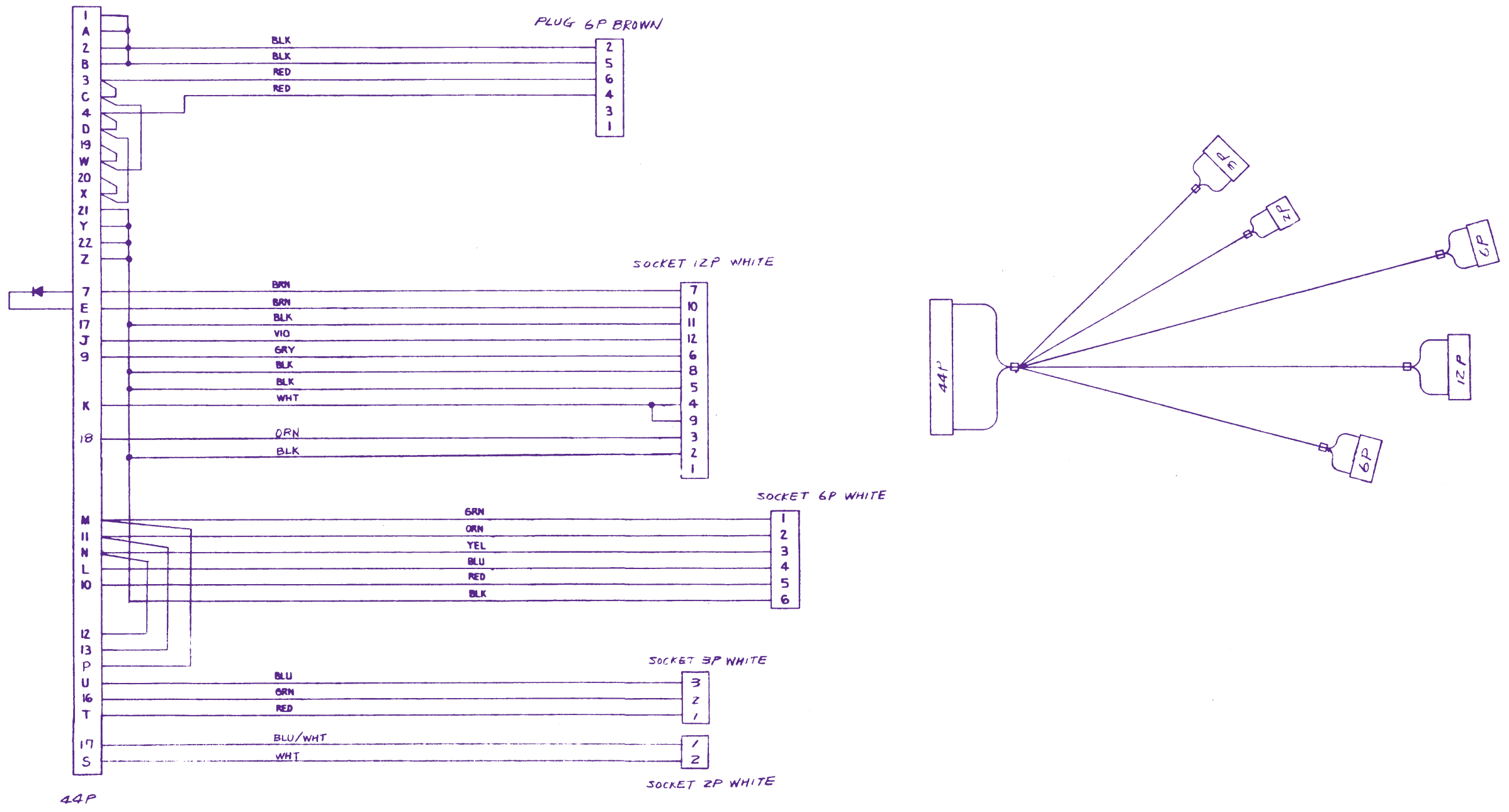

UNLESS OTHERWISE SPECIFIED DIMENSIONS ARE IN INCHES TOLERANCES ARE: FRACTIONS DECIMALS ANGLES ± .005 ± .005 ± .005		CONTRACT NO.		Gremlin Industries, Inc. San Diego, California 92133	
MATERIAL		APPROVALS		DATE	
FINISH		DRAWN		12/15/80	
700-0030		CHECKED		12/16/80	
NEXT ASSY USED ON		SCALE NONE		DRAWING NO. SGB-2835-1	
APPLICATION		DO NOT SCALE DRAWING		REV. 5	
				SHEET OF	