

TABLE OF CONTENTS

BEFORE USING THE PRODUCT, BE SURE TO READ THE FOLLOWING:

TABLE OF CONTENTS	i
INTRODUCTION	iii
1 HANDLING PRECAUTIONS	1
2 PRECAUTIONS REGARDING INSTALLATION LOCATION	4
2-1 LIMITATIONS OF USAGE	5
2-2 OPERATION AREA	6
3 PRECAUTIONS REGARDING PRODUCT OPERATION	7
3-1 BEFORE OPERATION	7
3-2 DURING OPERATION (PAYING ATTENTION TO CUSTOMERS)	9
4 PART DESCRIPTIONS	10
5 ACCESSORIES	11
6 ASSEMBLY AND INSTALLATION	13
7 PRECAUTIONS WHEN MOVING THE MACHINE	33
7-1 MOVING THE MACHINE	33
7-2 SEPARATING THE MAIN CABINET	35
8 GAME DESCRIPTION	37
9 EXPLANATION OF TEST AND DATA DISPLAY	49
9-1 VTS BOARD	51
9-2 SYSTEM TEST MODE	52
9-3 GAME TEST MODE	53
10 PROJECTOR	63
10-1 REMOTE CONTROL BUTTONS	64
10-2 AUTO COLOUR MATCHING	64
10-3 ADJUSTING ON-SCREEN CONTRAST	65
10-4 ADJUST ON-SCREEN BRIGHTNESS	66
10-5 ADJUSTING ON-SCREEN DISPLAY POSITION	67
10-6 ADJUSTING SCREEN SIZE	68
10-7 CONVERGENCE ADJUSTMENT	69
10-8 STATIC CONVERGENCE ADJUSTMENT	70
10-9 POINT CONVERGENCE ADJUSTMENT	71
10-10 LINE CONVERGENCE ADJUSTMENT	72

11	CONTROL UNIT	73
	11-1 HOW TO REPLACE THE MICROSWITCH	74
	11-2 HOW TO REPLACE THE SENSOR UNIT	77
	11-3 REPLACING THE SOLENOID.....	78
12	COIN SELECTOR & CREDIT SETTINGS.....	79
13	REPLACING THE FLUORESCENT LAMPS	84
14	PERIODIC INSPECTION.....	86
15	TROUBLESHOOTING	88
16	GAME BOARD	90
	16-1 HOW TO REMOVE GAME BOARD	91
	16-2 COMPOSITION OF THE GAME BOARD.....	93
17	DESIGN RELATED PARTS.....	94
18	PARTS LIST	95
19	WIRE COLOR CODE TABLE.....	138
20	WIRING DIAGRAM	139

INTRODUCTION

This manual is intended to provide detailed descriptions together with all the necessary information covering the general operation of electronic assemblies, electro-mechanicals, servicing control, spare parts, etc. for the product, "GHOST SQUAD - EVOLUTION."

This manual is intended for the owners, personnel and managers in charge of operation of the product. Operate the product after carefully reading and sufficiently understanding the instructions.

In the unlikely event that the product does not function correctly, DO NOT allow anyone other than a technician to touch the internal system. Turn off the power to the machine, making sure to unplug the electrical cord from the outlet, and contact the office listed below or the point-of-purchase for this product.

Use of this product is unlikely to cause physical injuries or damage to property. However, points that require special attention are indicated by bold text, the word "IMPORTANT" and the symbol below.



Indicates important information that, if ignored, may result in the mishandling of the product and cause faulty operation or damage to the product.

SEGA AMUSEMENTS EUROPE, LTD.

Suite 3a, Oaks House 12-22, West Street, Epsom, Surrey, KT18 7RG, United Kingdom

Telephone: +44 (0) 1372 731820 Facsimile: +44 (0) 1372 731849
e-mail: mailbox@sega.co.uk <http://www.sega-amusements.co.uk>

SPECIFICATIONS

Installation space	1,300 mm [Width] x 1,700 mm [Depth]
Height:	2,230 mm
Weight:	253kg
Power, maximum current:	3A, (AC 230 V, 50 Hz Area)
Monitor:	Toshiba 50" Projection Type.
Operating Temperature:	5-30 degrees C.

NOTE: The contents herein described are subject to change without notice.

Definition of 'Site Maintenance Personnel or Other Qualified Individuals'**⚠ WARNING**

Procedures not described in this manual or marked as 'to be carried out by site maintenance personnel or other qualified professionals' should not be carried out by personnel without the necessary skill or technology. Work carried out by unqualified persons may cause serious accidents, including electrocution.

Parts replacement, maintenance inspections and troubleshooting should be carried out by site maintenance personnel or other qualified professionals. This manual includes directions for potentially dangerous procedures which should only be carried out by professionals with the appropriate specialized knowledge.

The site maintenance personnel or other qualified professionals mentioned in this manual are defined as follows:

Site maintenance personnel:

Individuals with experience in maintaining amusement equipment, vending machines, etc., working under the supervision of the owner/operator of this product to maintain machines within amusement facilities or similar premises by carrying out everyday procedures such as assembly, maintenance inspections, and replacement of units/expendable parts.

Activities to be carried out by site maintenance personnel:

Amusement equipment/vending machine assembly, maintenance inspection and replacement of units/expendable parts.

Other qualified professionals:

Persons employed by amusement equipment manufacturers, or involved in design, production, testing or maintenance of amusement equipment. The individual should have either graduated from technical school or hold similar qualifications in electrical/electronics/mechanical engineering.

Activities to be carried out by other qualified professionals:

Amusement equipment/vending machine assembly, repair/adjustment of electrical/electronic/mechanical parts.

BEFORE USING THE PRODUCT, BE SURE TO READ THE FOLLOWING:

To maintain safety:

To ensure the safe operation of this product, be sure to read the following before usage. The following instructions are intended for the users, operators and the personnel in charge of the operation of the product. After carefully reading and sufficiently understanding the warning displays and cautions, handle the product appropriately. Be sure to keep this manual close to the product or in a convenient place for future reference.

Herein, explanations which require special attention are enclosed with dual lines. Depending on the potentially hazardous degrees, the terms of DANGER, WARNING, CAUTION, etc. are used. Be sure to understand the contents of the displays before reading the text.



Indicates that mishandling the product by disregarding this pictograph will cause severe injury or death.



Indicates that mishandling the product by disregarding this caution will cause a slight hazardous situation which can result in personal injury and/or material damage.



Indicates that mishandling the product by disregarding this warning will cause a potentially hazardous situation which can result in death or serious injury.

For the safe usage of the product, the following pictographs are used:



Indicates "HANDLE WITH CARE." In order to protect the human body and equipment, this display is attached to places where the Owner's Manual, Serviceman Manual and/or Service Manual should be referred to.



Indicates a "Protective Earth Terminal." Before operating the equipment, be sure to connect it to the Ground.
(The step may be omitted for products in which a power cord with earth is used.)

- **Perform work in accordance with the instructions herein stated.**
Instructions for work are explained by paying attention to the aspect of accident prevention. Failing to perform work as per the instructions can cause accidents. In the case where only those who have technical expertise should perform the work to avoid hazardous situation, the instructions herein state that the site maintenance personnel should perform such work.
- **Be sure to turn off the power before working on the machine.**
To prevent an electric shock, be sure to turn off the power before carrying out any work that requires direct contact with the interior of the product. If the work is to be performed in the power-on status, the Instruction Manual herein always states to that effect.
- **Be sure to ground the Earth Terminal.**
(This is not required in the case where a power cord with earth is used.)
This product is equipped with the Earth Terminal. When installing the product, connect the Earth Terminal to the "accurately grounded indoor earth terminal" by using an earth wire. Unless the product is grounded appropriately, the user can be subject to an electric shock. After performing repair, etc. for the control equipment, ensure that the Earth Wire is firmly connected to the control equipment.
- **Ensure that the Power Supply used is equipped with an Earth Leakage Breaker.**
This product does not incorporate the Earth Leakage Breaker. Using a power supply which is not equipped with the Earth Leakage Breaker can cause a fire when earth leakage occurs.
- **Be sure to use fuses which meet the specified rating.**
(Only for the machines which use fuses.)
Using fuses exceeding the specified rating can cause a fire and an electric shock.

1 HANDLING PRECAUTIONS

When installing or inspecting the machine, be very careful of the following points and pay attention to ensure that the player can enjoy the game safely.

Non-compliance with the following points or inappropriate handling running counter to the cautionary matters herein stated can cause personal injury or damage to the machine.

WARNING

- Before performing work, be sure to turn the power off. Performing the work without turning the power off can cause an electric shock or short circuit. In the case work should be performed in the status of power on, this manual always states to that effect.
- To avoid an electric shock or short circuit, do not plug in or unplug quickly.
- To avoid an electric shock, do not plug in or unplug with a wet hand.
- Do not expose power cords or earth wires on the surface, (floor, passage, etc.). If exposed, the power cords and earth wires are susceptible to damage. Damaged cords and wires can cause an electric shock or short circuit.
- To avoid causing a fire or an electric shock, do not put things on or damage the power cords.
- When or after installing the product, do not unnecessarily pull the power cord. If damaged, the power cord can cause a fire or an electric shock.
- In case the power cord is damaged, ask for a replacement through where the product was purchased from or the office herein stated. Using the cord as is damaged can cause fire, an electric shock or leakage.
- Be sure to perform grounding appropriately. Inappropriate grounding can cause an electric shock.
- Be sure to use fuses meeting the specified rating. Using fuses exceeding the specified rating can cause a fire or an electric shock.
- Be sure that connections such as IC BD are made properly. Insufficient insertion can cause an electric shock.
- Specification changes, removal of equipment, conversion and/or addition, not designated by SEGA are not permitted.
 - Failure to observe this may cause a fire or an electric shock. Non-compliance with this instruction can have a bad influence upon physical conditions of the players or the onlookers, or result in injury during play.
 - SEGA shall not be held responsible for damage, compensation for damage to a third party, caused by specification changes not designated by SEGA.
- Do not perform any work or change parts not listed in this manual. Doing so may lead to an accident.

If you need to perform any work not listed in this manual, request work from the office indicated in this manual or the point of purchase, or inquires for details.
- Be sure to perform periodic maintenance inspections herein stated.

STOP IMPORTANT

- For the IC board circuit inspections, only the logic tester is allowed. The use of a multiple-purpose tester is not permitted, so be careful in this regard.
- The projector is employed for this machine. The projector's screen is susceptible to damage, therefore, be very careful when cleaning the screen. For details, refer to the section "Projector."
- Static electricity from your body may damage some electronics devices on the IC board. Before handling the IC board, touch a grounded metallic surface so that the static electricity can be discharged.
- Some parts are not designed and manufactured specifically for this game machine. The manufacturers may discontinue, or change the specifications of such general-purpose parts. If this is the case, SEGA cannot repair or replace a failed game machine whether or not a warranty period has expired.

CONCERNING THE STICKER DISPLAY



This SEGA product has stickers attached describing the product manufacture No. (Serial No.) and Electrical Specifications. It also has a Sticker describing where to contact for repair and for purchasing parts.

When inquiring about or asking for repairs, mention the Serial No. and Name of Machine indicated on the Sticker. The Serial Number indicates the product register. Identical machines could have different parts depending on the date of production. Also, improvements and modifications might have been made after the publication of this manual. In order to ensure you order the correct parts, mention the Serial No. when contacting the applicable places.

CONCERNING WARNING DISPLAYS

This SEGA product has warning displays on stickers, labels and/or printed instructions adhered/attached to or incorporated in the places where a potentially hazardous situation could arise. The warning displays are intended for accident prevention for customers and for avoiding hazardous situations relating to maintenance and servicing work. Some portions of the cabinet contain high voltage and may cause accidents if touched. When performing maintenance, be very careful of the warning displays. It is especially important that any complex repair and replacement work not mentioned herein should be performed by those technical personnel who have knowledge of electricity and technical expertise. In order to prevent accidents, caution any customer ignoring the warnings to cease and desist immediately.



 <p>WARNING</p>	 <p>WARNING!</p>
<p>High voltage can cause an electric shock. Turn off power before servicing.</p>	<p>Hot light bulbs can cause burns. Be very careful when replacing them.</p>

2 PRECAUTIONS REGARDING INSTALLATION LOCATION

WARNING

This product is an indoor game machine. Do not install it outside. Even indoors, avoid installing in places mentioned below so as not to cause a fire, electric shock, injury and/or malfunction.

- Places subject to rain or water leakage, or places subject to high humidity in the proximity of an indoor swimming pool and/or shower, etc.
- Places subject to direct sunlight, or places subject to high temperatures in the proximity of heating units, etc.
- Places filled with inflammable gas or vicinity of highly inflammable/volatile chemicals or hazardous matter.
- Dusty places.
- Sloped surfaces.
- Places subject to any type of violent impact.
- Vicinity of anti-disaster facilities such as fire exits and fire extinguishers.
- The operating (ambient) temperature range is not from 5°C to 30°C.
- Places near water or spray from water such as a Jet Wash or Swimming Pool.

2-1 LIMITATIONS OF USAGE

WARNING

- Be sure to check the Electrical Specifications. Ensure that this product is compatible with the location's power supply, voltage, and frequency requirements. A plate describing Electrical Specifications is attached to the product. Non-compliance with the Electrical Specifications can cause a fire and electric shock.
- This product requires a breaker and earth mechanism as part of the location facilities. Using the product without these can cause a fire and electric shock.
- Ensure that the indoor wiring for the power supply is rated at 15 A or higher (AC single phase 100 V ~ 120 V area), and 7 A or higher (AC 220 V ~ 240 V area). Non-compliance with the Electrical Specifications can cause a fire and electric shock.
- Be sure to use an independent power supply equipped with an earth leakage breaker. Using a power supply without an earth leakage breaker can cause an outbreak of fire if a power surge occurs.
- Putting many loads on one electrical outlet can cause generation of heat and a fire resulting from overload.
- When using an extension cord, ensure that the cord is rated at 15 A or higher (AC 100 V ~ 120 V area) and 7 A or higher (AC 220 V ~ 240 V area). Using a cord rated lower than the specified rating can cause a fire and electric shock.

Electricity Consumption:
RATED 2.5 @ 230VAC-240VAC

2-2 OPERATION AREA

WARNING

- For the operation of this machine, secure a minimum area of 2.94 m (W) x 3.96 m (D). If the machine rolls during play it could lead to serious injury, especially if anyone is hit on the head. You must secure the space specified in this document.
- Be sure to provide sufficient space specified in this manual. Do not allow objects to block the ventilation ports. It can cause generation of heat and a fire.
- SEGA shall not be held responsible for damage or compensation for damage to a third party, resulting from the failure to observe this instruction.
- If the machine does not fit through the entryway to the installation location, do not disassemble it without first consulting the instructions. If the machine still does not fit through the entryway after following the procedures in this manual, contact your retailer or the office listed in this manual.

IMPORTANT

To install this product, the entrance must be at least 1.20 m in width and 1.90 m in height.

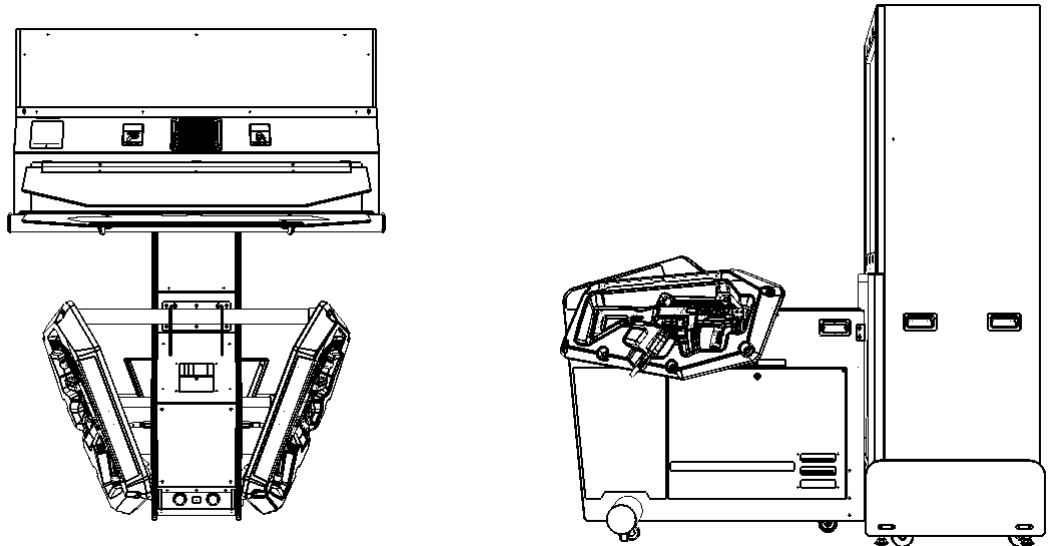

FIG. 2 Installation and operation area (cm)

3 PRECAUTIONS REGARDING PRODUCT OPERATION

To avoid injury and trouble, be sure to pay attention to the behavior of visitors and players.

3-1 BEFORE OPERATION

WARNING

In order to avoid accidents, check the following before starting the operation:

- To ensure maximum safety for the players and the customers, ensure that where the product is operated has sufficient lighting to allow any warnings to be read. Operation under insufficient lighting can cause bodily contact with each other, hitting accident, and/or trouble between customers.
- Be sure to perform appropriate adjustment of the monitor (projector). For operation of this machine, do not leave monitor's flickering or deviation as is. Failure to observe this can have a bad influence upon the players' or the customers' physical conditions.
- It is suggested to ensure a space allowing the players who feel sick while playing the game to take a rest.
- Check if all of the adjusters are in contact with the surface. If they are not, the Cabinet can move and cause an accident.

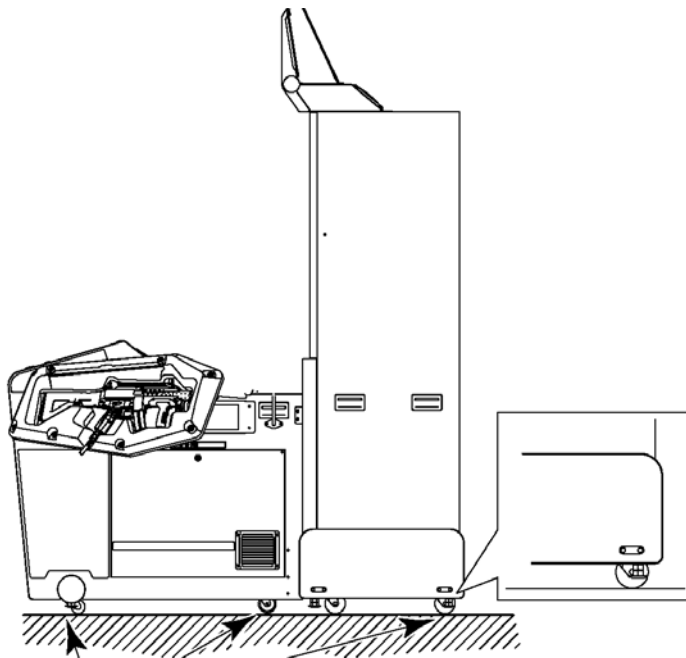

Have caster make contact with the floor

⚠ WARNING

- Do not put any heavy item on this product. Placing any heavy item on the product can cause a falling down accident or parts damage.
- Do not climb on the product. Climbing on the product can cause falling down accidents. To check the top portion of the product, use a step ladder.
- When using a stepladder or stool while working, do not hold onto the billboard carrier (the round pipe section). Holding or hanging off this may bend it out of shape or damage it, and could lead to a fall or an accident.
- To avoid electric shock, check to see if door & cover parts are damaged or omitted.
- To avoid electric shock, short circuit and/or parts damage, do not put the following items on or in the periphery of the product.

[Flower vases, flowerpots, cups, water tanks, cosmetics, and receptacles/containers/vessels containing chemicals and water.]

⚠ CAUTION

- To avoid injury, be sure to provide sufficient space by considering the crowd situation at the installation location. Insufficient installation space can cause customers to bump into each other, causing trouble.
- Every day when cleaning the Control Unit (Gun), inspect the gun and make sure that there are no scratches or cracks in the surface, and that the fastening screws are not loose. If the game is played with scratches, cracks or loose screws, it can cause injuries to the player or to people nearby.

Ensure that the trigger is functioning properly.

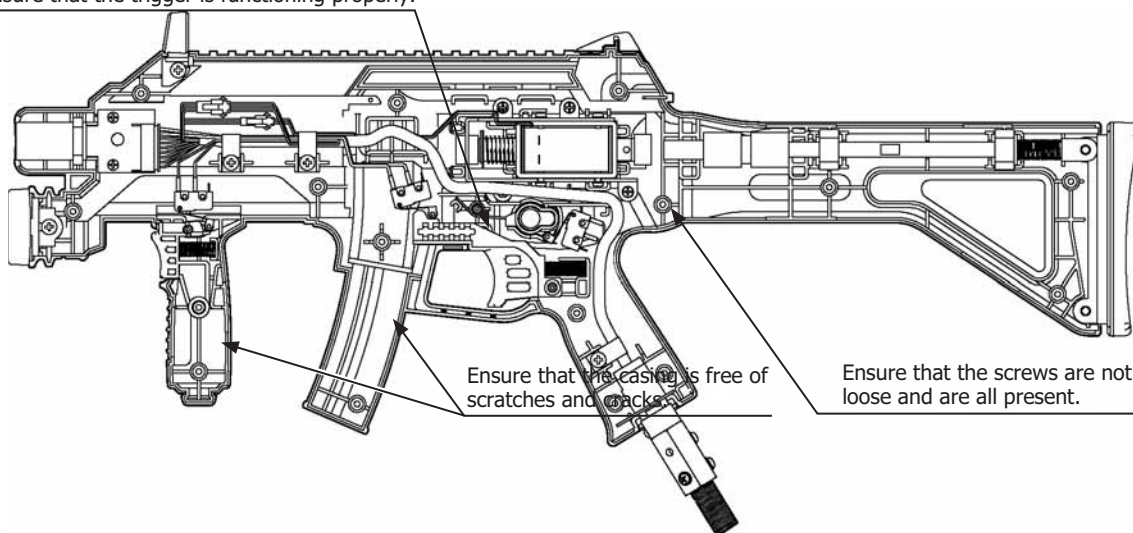

Ensure that the casing is free of scratches and cracks.

Ensure that the screws are not loose and are all present.

STOP IMPORTANT

To ensure customers enjoy playing the game, clean the Control Unit regularly. If there is any dirt buildup, the trigger may not return properly after being pulled.

3-2 DURING OPERATION (PAYING ATTENTION TO CUSTOMERS)

To avoid injury and trouble, be sure to pay attention to the behavior of visitors and players.

WARNING

- For safety reasons, do not allow any of the following people to play the game.
 - Those who require supporting devices, etc., to walk.
 - Those who have high blood pressure or a heart problem.
 - Those who have experienced muscle convulsion or loss of consciousness when playing video games, etc.
 - Those who have neck or spinal cord problems.
 - Intoxicated persons.
 - Pregnant women.
 - Persons susceptible to motion sickness.
 - Persons who disregard the product's warning displays.
- Even players who have never been adversely affected by light stimulus might experience dizziness or headache depending on their physical condition when playing the game. Small children are especially likely to experience these symptoms. Caution guardians of small children to keep watch on their children during play.
- Instruct those who feel sick during play to have a medical examination.
- To avoid injury from falls and electric shocks due to spilled drinks, instruct the player not to place heavy items or drinks on the product.
- To avoid electric shocks and short circuits, do not allow customers to put hands and fingers or extraneous matter in the openings of the product or small openings in or around the doors.
- To avoid falls and resulting injury, stop the customer from leaning against or climbing on the product, etc.
- To avoid electric shock and short circuit, do not allow customers to unplug the power plug without a justifiable reason.

4 PART DESCRIPTIONS

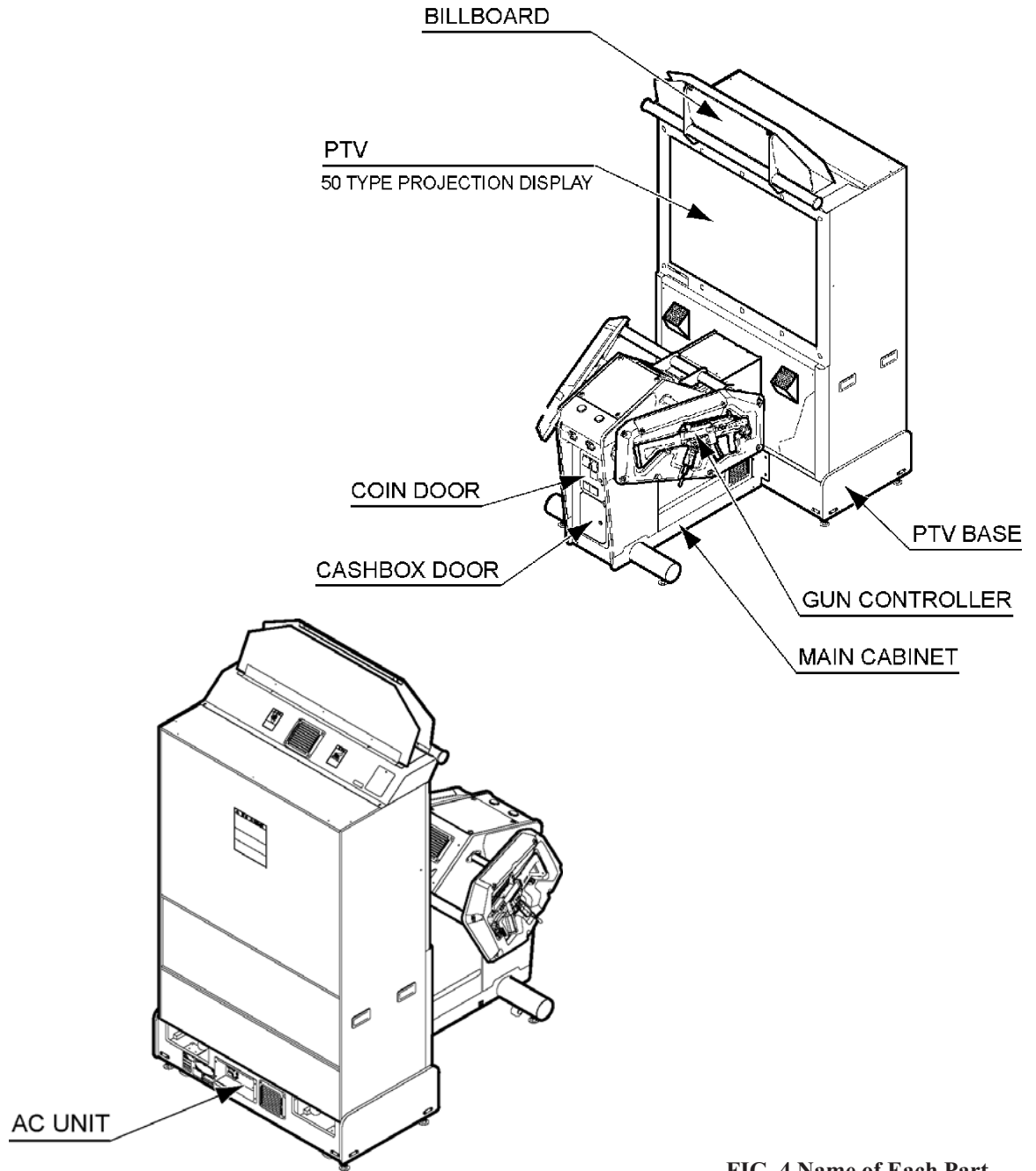

FIG. 4 Name of Each Part

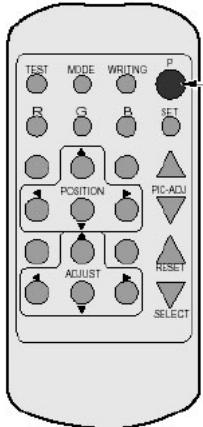
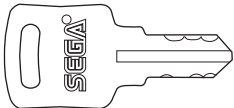
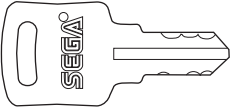
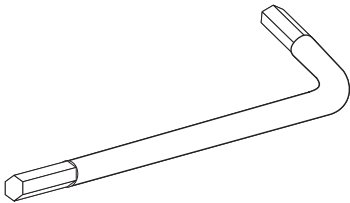

TABLE 4 Major Measurements of Each Unit Upon Purchase

	(Width x Depth x Height)	(Weight)
Gun Cabinet	1,140 mm × 1,090 mm × 1,010 mm	98 kg
PTV Cabinet	1,140 mm × 555 mm × 1,670 mm	100 kg
PTV Base	1,200 mm × 620 mm × 310 mm	26 kg
Billboard	1,170 mm...x...410 mm x 385 mm	18 kg
When Assembled	1,200 mm x 1,680 mm x 2,230 mm	253 kg

5 ACCESSORIES

Confirm that the accessories listed in the table below are present when setting up the product. Accessories marked "Spare" in the note column are consumable items but included as spares.

TABLE 5a

<p>OWNER'S MANUAL 420-6831-11UK (1) This manual</p>	<p>LINDBERGH SERVICE MANUAL 420-6921-01UK (1) Description of mounted Game Board</p>	<p>REMOTE CONTROL FOR PTV</p>
<p>MASTER KEY 220-5575UK (2) For opening/closing the doors (Packaged with this manual, in the box supplied with the product)</p>	<p>KEY (2) For the cashbox door (Located inside the coin chute door at time of shipment)</p>	
		
<p>WRENCH FOR TAMPERPROOF SCREWS (M4) 540-0006-01 (1) Tool, see chapter 11</p>	<p>WRENCH FOR TAMPERPROOF SCREWS (M5) 540-0007-01 (1) Tool, see chapter 11</p>	
		
<p>STICKER INSTRUCTION (GE-1001UK)</p>		
		

The parts listed in Table 5b must always be attached when using the product. They are attached while assembling and installing the product.

TABLE 5b

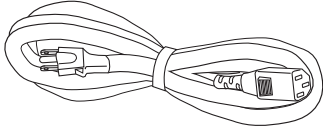
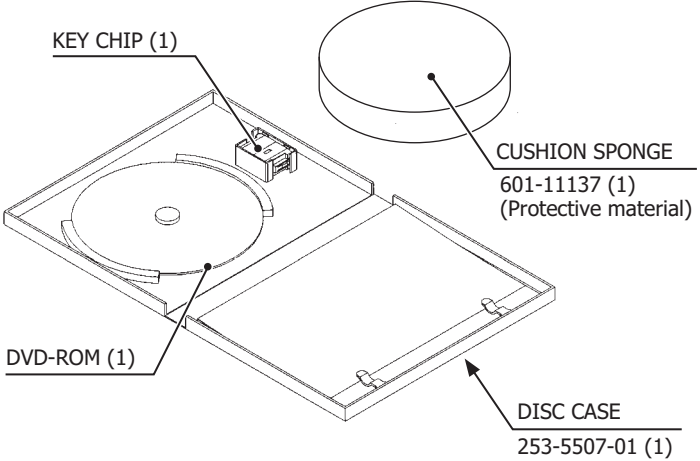
<p>POWER CABLE 600-6729-01 (1) <Taiwan> 600-6619-02 (1) <Singapore, Malaysia> 600-6618-01 (1) <Others> For installation, see chapter 6</p>	<p>STICKER 840-0012D-02 443-40012D-02 (1) Board number stickers, see chapter 6 [11]</p>	<p>844-0012D-02</p>
	<p>DVD SOFTWARE KIT (1) Software media, see chapter 6 [13]</p>	
<p>To order the DVD-ROM by itself, use the following part number: 610-0727-0029 (DVD SOFT GSE).</p>		

DVD DRIVE and DVD wire are sold separately but they are required for installing the product's software. If they were not provided when the product was delivered, consult with the point of purchase, or arrange to obtain the following kit numbers. The DVD DRIVE and DVD wire that are accessories to "The House of the Dead 4" can also be used with this product.

TABLE 5c XKT-1515-01: DVD DRIVE KIT FOR LBG ENG

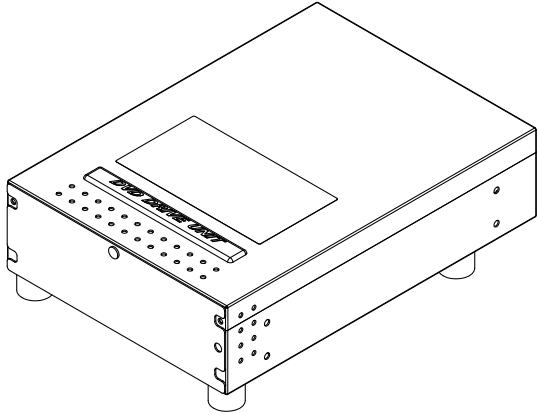
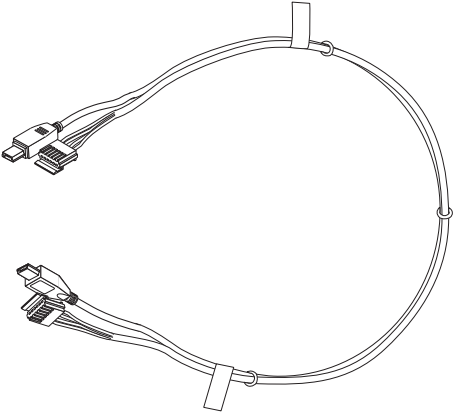
<p>DVD DRIVE (Optional) 610-0719-01-91 (1) For software installation, see chapter 6 [11]</p>	<p>DVD WIRE (Fitted) 605-0094 (1) For software installation, see chapter 6 [11]</p>
	

6 ASSEMBLY AND INSTALLATION

WARNING

- Perform assembly work by following the procedure herein stated. Failure to comply with the instructions can cause electric shock.
- Perform assembling as per this manual. Since this is a complex machine, incorrect assembling can cause an electric shock, machine damage and/or improper functioning as per specified performance.
- When assembling, more than one person is required. Depending on the assembly work, there are some cases in which working by one person alone can cause personal injury or parts damage.
- Ensure that connectors are properly connected. Improper connections can cause electric shock.
- Be careful not to damage the wires. Damaged wires may cause electric shock or short circuit or present a risk of fire.
- This work should be carried out by site maintenance personnel or other qualified professionals. Work performed by non-technical personnel can cause a severe accident such as electric shock. Failing to comply with this instruction can cause a severe accident such as electric shock to the player during operation. If no one with proper technological expertise is available, request service from the office indicated in this document or the point of purchase so as to ensure safety.
- Provide sufficient space so that assembling can be performed. Performing work in places with narrow space or low ceiling may cause an accident and assembly work to be difficult.
- To perform work safely and avoid serious accident such as the cabinet falling down, do not perform work in places where step-like grade differences, a ditch, or slope exist.
- Do not leave power cords or ground wires exposed in areas of heavy foot traffic. Doing so may cause them to become damaged, possibly resulting in electric shock and/or short circuits. When laying wiring across the floor, always use safety covers to protect the wires. (Wiring diameter: power cable - approx. \varnothing 8)
- Have a flashlight or another supplementary lighting unit available while working. With indoor lighting alone, the cabinet interior may be too dark. Working without proper lighting can lead to accidents. It also hinders proper work performance.
- The cabinet has ventilation ports. Be sure not to block them. If they are blocked, heat can build up, leading to fire. This can also accelerate wearing of parts and malfunctions.
- Secure ample ventilation space around the cabinet. If heat builds up, there could be accidents associated with heat or smoke generation.
- Do not unnecessarily push the projector. This could cause the unit to tip over.
- This product does not use any connectors other than those connected to and used by the game board when it leaves the factory. Do not needlessly connect wires to unused connectors. This could lead to overheating, generation of smoke and burn related injuries.

⚠ CAUTION

- Handle moulded parts with care. Excessive weight or pressure may cause them to break and the broken pieces may cause injury.
- To perform the operation safely and accurately you must use a safe, steady footstool or stepladder. Working without this may lead to a fall and possible injury.
- When connecting the connectors on the DVD wire, you must carefully check the tags on the wire to find the correct connector. Even when you have the correct connector, you must pay careful attention to the direction and angle of insertion. Attempting to forcefully connect the incorrect connector or connecting a connector at the wrong angle or facing may damage the connector and could lead to overheating and burn related injuries.
- When attaching or removing doors or lids, be careful that your hand or finger does not get caught in anything.

STOP IMPORTANT

- Be very careful when handling the projector screen. The screen can be damaged easily and cannot be repaired once damaged. Such damage can only be repaired by completely replacing the screen.
- Be careful not to damage parts surfaces. In some cases, if such surfaces are damaged, the part must be replaced; it cannot be reinforced or repaired.
- This product is a game machine for indoor use only Do not install it outdoors. Even indoors, do not install it in the following places. Such locations can cause fire, electric shock, injury or breakdowns.
 - Areas exposed to direct sunlight, close to heating equipment, or other hot places.
 - Areas exposed to leakage of rainwater, or in very humid places, such as close to an indoor pool or shower.
 - Areas filled with flammable gas, or near to chemicals or hazardous substances that are highly flammable or volatile.
 - Areas with high dust concentrations.
 - Inclined surfaces.
 - Areas of intense vibration.
 - Close to safety equipment such as emergency exits and fire extinguishers
- Areas outside the appropriate usage temperature (ambient temperature) range is 5 to 30 degrees Centigrade.

The assembly of this product is performed in the following 6 steps.

- 1 ASSEMBLING THE BILLBOARD
- 2 ASSEMBLING THE CABINET
- 3 SECURING INTO LOCATION
- 4 CONNECTING THE DVD DRIVE
- 5 APPLYING POWER FOR THE FIRST TIME
- 6 ENGAGEMENT OF POWER SUPPLY AND SOFTWARE INSTALLATION
- 7 CONFIRMATION OF ASSEMBLY

Tools Required for Assembly Operation

- Philips screwdriver (for M4, M6 screws)

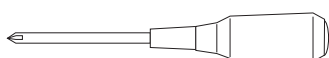

- A 7, 10 millimeter socket wrench or hexagonal screwdriver (for M4, M6 hexagon bolts and nuts)

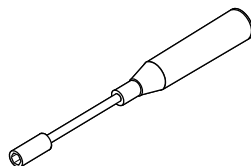
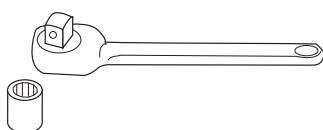

A 24 millimeter spanner (Adjustable spanner)

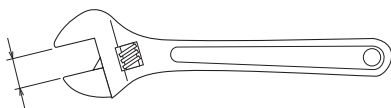

24mm

- Master key (accessory)

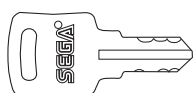

- Stepladder

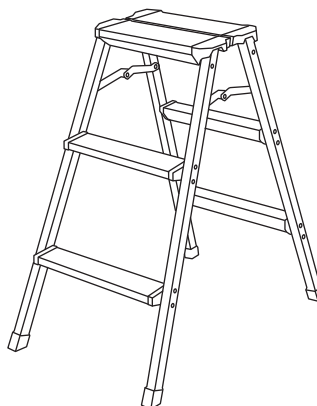

1 ASSEMBLING THE BILLBOARD

The Billboard can be heavy. Two people are required to install the billboard once assembled..”

- 1 Place the ASSY BILLBOARD on to a flat surface and remove the 2x truss screws which secure the Pop Bracket

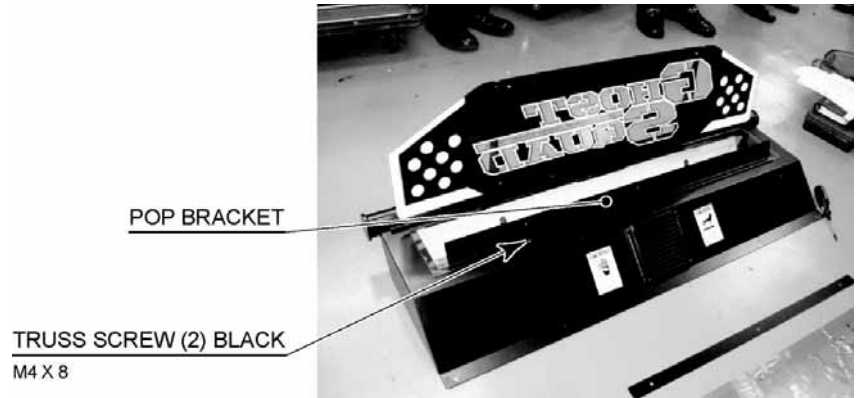

FIG. 6-1a

- 2 Once the Pop Bracket has been removed. Undo the 3x truss screws which secure the Pop Holder to the Pop Bracket.

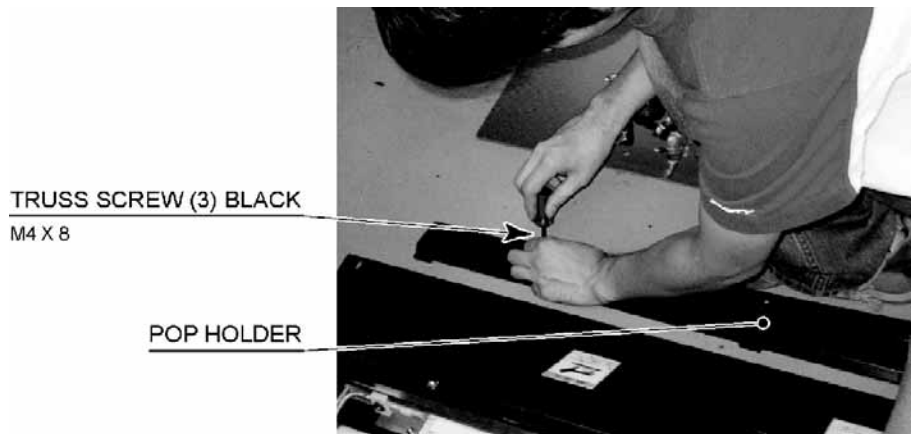

FIG. 6-1b

- 3 Attach the Billboard Pop Panel to the Billboard by fitting it between the Pop Bracket and Pop Holder. Secure it in place using the 3x truss screws removed in step 2.

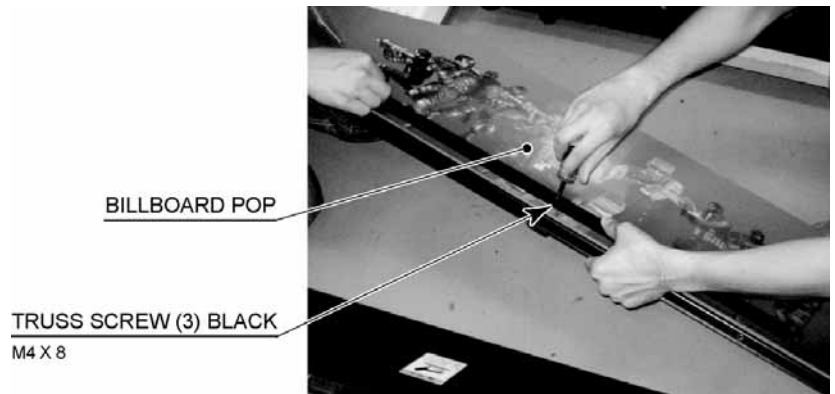

FIG. 6-1c

- 4** Attach the now assembled Billboard Pop Panel to the Billboard using the 2x truss screws which were removed from step 1

TRUSS SCREW (2) BLACK
M4 X 8



FIG. 6-1d

2 ASSEMBLING THE CABINET

- 1** Locate the PTV to the back of the PTV Base. Once in position, have 2 people to lift the PTV and a third person to stabilise it from behind. Once the PTV is clear of the PTV Base, have a fourth person slide the PTV Base underneath the PTV. Once aligned with the Base the PTV can be lowered in to position. Be careful not to trap any wires during this operation.

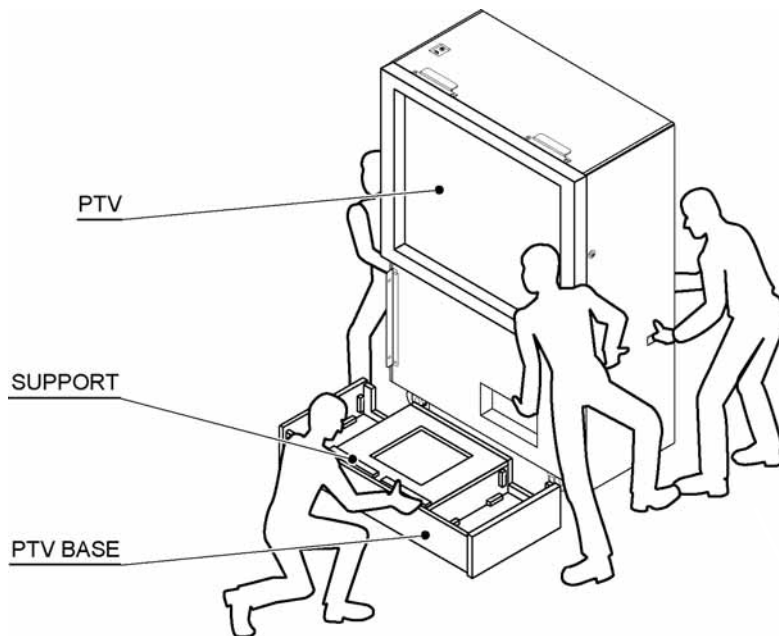

FIG. 6-1e

- 2** Attach the Front Panel to the PTV by using 4x truss screws. Take care again not to damage any wiring or graphics during this operation.

FRONT PANEL

TRUSS SCREW (4) BLACK
M5 X 20, flat washer used



FIG. 6-1f

3 IMPORTANT. - 2 people are required for this operation as the Billboard is HEAVY. Lift the Billboard so that it is positioned centrally on the PTV. Carefully lower the Billboard onto the PTV as not to trap any wires. Then slowly slide the Billboard forward towards the screen so that Billboard latches onto the clasps on the upper part of the mask.



FIG. 6-1g

4 A Stepladder will be needed to perform the next operation. Once the Billboard is in location, attach it in to position using 2x truss screws supplied in the installation kit.

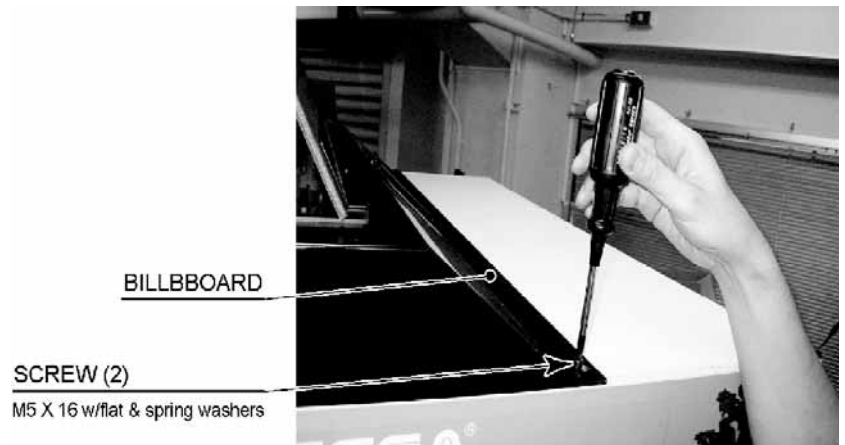

FIG. 6-1h

5 To connect the Billboard lamps, the next step is so remove the connector lid from the rear of the Billboard.

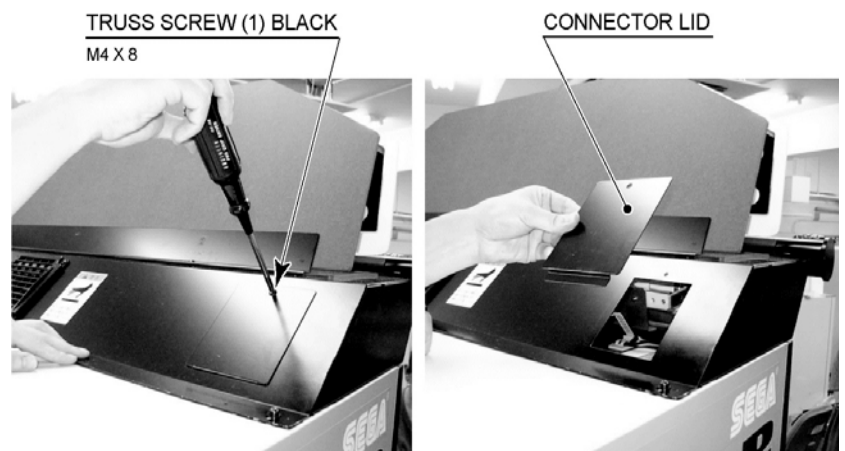

FIG. 6-1i

6 Once the Connector Lid is removed. Locate the Billboard Harness and connect the 2x connectors into the top of the PTV.

BILLBOARD INTERNAL CONNECTOR

PTV CEILING CONNECTOR



FIG. 6-1j

7 Once connected. Re-attach the Connector lid using the 1x truss removed in step 6.

8 The next step is to attach the Gun Cabi to the Display Cabi. Firstly bring the two cabinet together. Connect the wiring between the to cabinets. There are a total of 6 connection to make.

CONNECTOR (5)

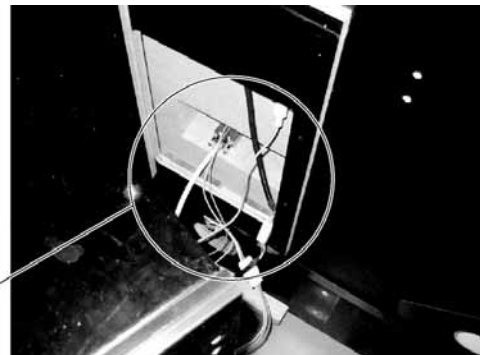

FIG. 6-1k

Be careful not to pinch the wiring

SUPPORT

MAIN CABINET



- Carefully place the Gun cabi on to the support of the Display Cabi (be careful not to trap any wires). Fix the two cabinets together by securing the left and right brackets of the Gun Cabi to the Display cabi using 4x M8 Hex Bolts Black.

HEXAGON BOLT (2 ea), black
 M8 X 40 w/spring washer flat washer used

BRACKET

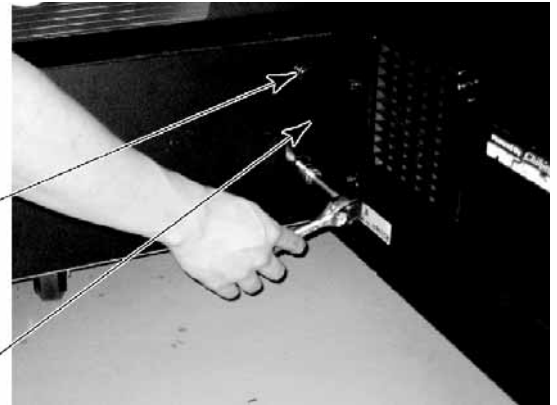
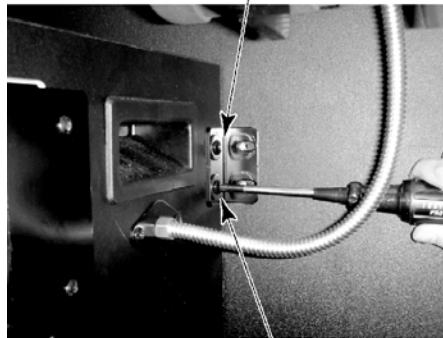

FIG. 6-11

- Finally attach the joint brackets upper from the Gun Cabi to the Display Cabi using 4x truss screws on each side of the joint. arrange these so that the vertical hole positions correspond to the holes in the Display Cabi and the horizontal holes correspond to the Gun Cabi. If there is a slight gap between the two cabinets, ensure that adjusters are equally level before tightening.

JOINT BRACKET UPPER



TRUSS SCREW (4 ea), BLACK
 M5 X 20, flat washer used

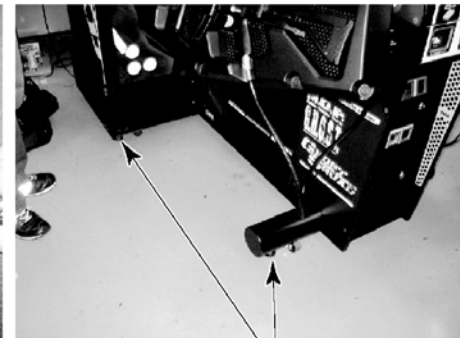

ADJUSTER

FIG. 6-1m

⚠ WARNING

Make sure that all the adjusters contact the floor. Otherwise the cabinet could move, causing an accident.

The product comes with casters attached at 8 locations and adjusters at 6 locations (Fig. 6-2a). When the installation site has been determined, have the adjusters come in direct contact with the floor. Establish a gap of about 5 mm between the floor and the casters and adjust the unit so that it will remain level.

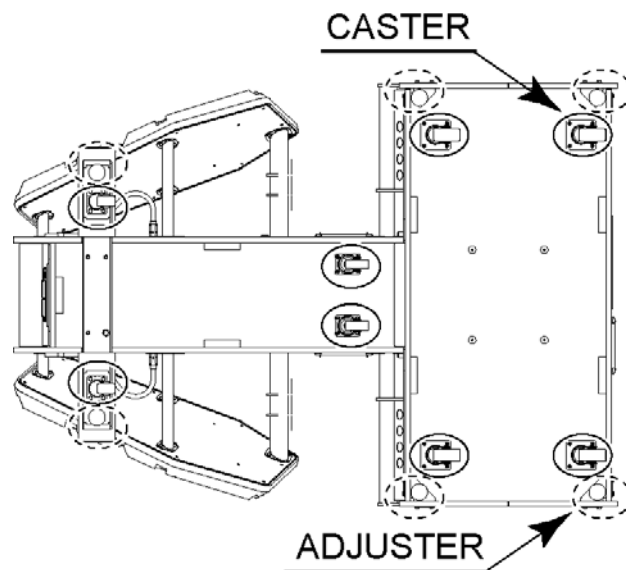

FIG. 6-2a Bottom View

- 1** Move the product to the installation site. If the product is to be installed near a wall, secure enough passageway space. You must also secure a 50 cm space between the back wall and the back of the cabinet for ventilation.
- 2** Bring the adjusters into direct contact with the floor. Use a wrench to align the height of the adjusters until the cabinet is perfectly level.
- 3** After setting, turn adjuster nuts upwards to tighten them and secure adjuster heights.

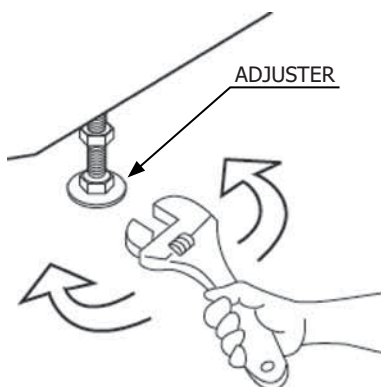

FIG. 6-2b Aligning the Adjusters

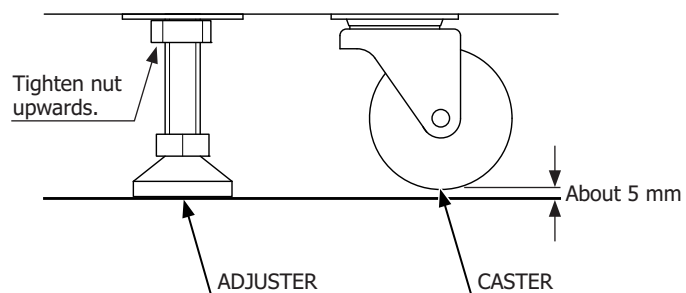

FIG. 6-2c Aligning the Adjusters

Views are reduced to 1/100. Use them for reference in installation site layout.

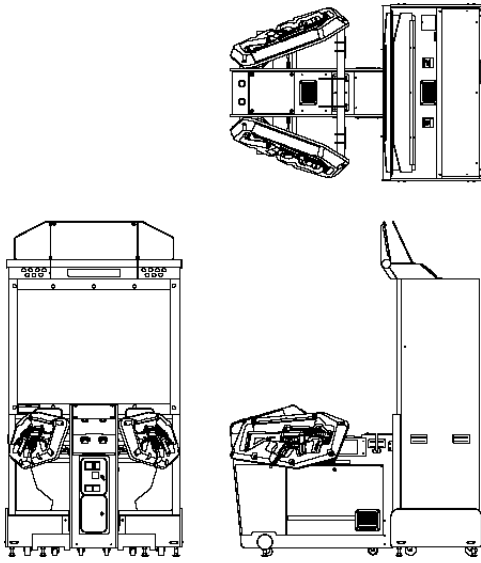

FIG. 6-2d Three Surface Views

You must secure a 150mm ventilation space between the back of the DLP and the wall.

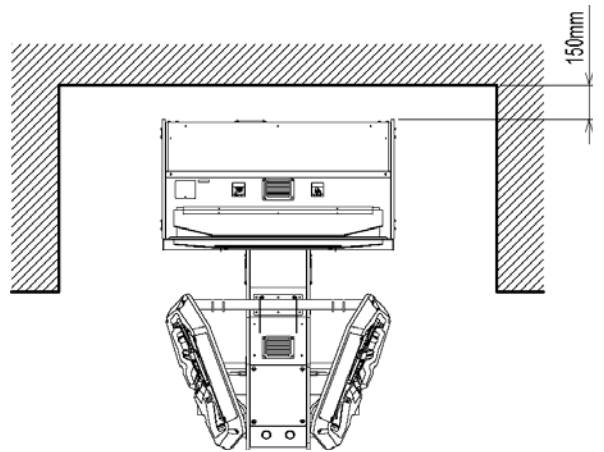

FIG. 6-2e Ventilation Space

4 CONNECTING THE DVD DRIVE (PREPARATION FOR INSTALLATION)

PLEASE NOTE THAT THIS PRODUCT IS DELIVERED WITH SOFTWARE PRE-INSTALLED

⚠ WARNING

- When connecting the DVD wire connector, check the orientation carefully and connect securely. The connector must be connected in the proper direction. If it is connected in the wrong direction or indiscriminately at an incline so that a load is applied, the connector or its terminal pins could break, causing a short circuit or fire.
- Be careful not to damage the DVD wire by getting it caught between objects, etc. Doing so may cause a short circuit or fire.
- Connect the DVD DRIVE to the LINDBERGH before connecting the power. Adhere strictly to the proper sequence in performing work. Failing to do so may cause electrical shock or short circuit.

You will need the supplied DVD software kit, board number sticker, and the separately sold DVD DRIVE and DVD wire. To prepare for software installation, you will need to connect the LINDBERGH and DVD DRIVE inside the cabinet using the DVD wire.

The LINDBERGH is the orange colored plate metal case found inside the front door PCB on the left side when facing the projector screen.

- 1 Remove the left right side door from the main cabinet by unscrewing the 2x m4x40 machine screws.

FIG. 6-11a



- 2 Remove the door to reveal the Lindbergh game board.

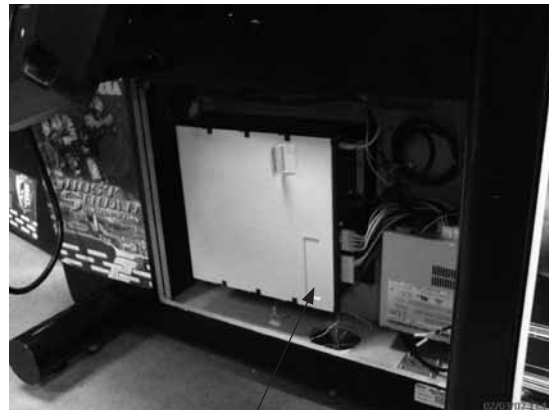

Lindbergh Game Board

FIG. 6-11b

- 3 Locate the two connections (circled) required for the DVD drive unit.



FIG. 6-11c

- 4 Remove the key chip from the DVD kit case and insert it into the LINDBERGH. Make sure it is inserted in the proper direction. (The keychip will already be inserted on all European models.)
- 5 Connect the two connectors on the DVD wire that have the "LINDBERGH" tag on them to the LINDBERGH. The LINDBERGH has four USB connectors. You can use any two connectors.
- 6 On the side of the DVD wire with the "DVD" tag, there are two connectors. Connect them to the DVD DRIVE.

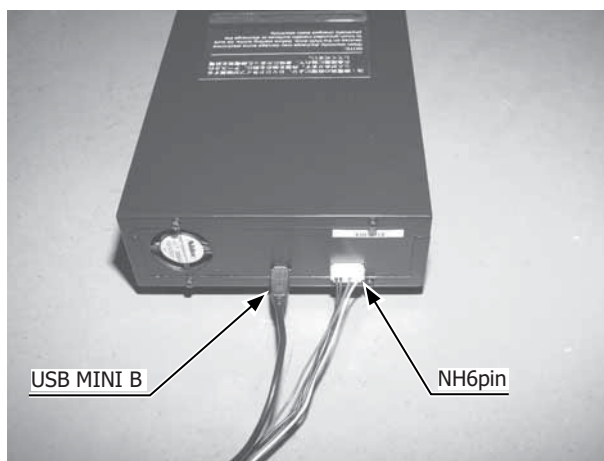

FIG. 6-11d

5 APPLYING POWER FOR THE FIRST TIME

WARNING

- Use the power supply equipped with an earth leakage breaker. Use of power supply without such a breaker could result in fire if there is a current leakage.
- This product **MUST** be earthed. Operating this product without an earth connection will result in either a fire hazard, or Severe electric shock. .
- Do not expose the power cords. If these are exposed, customers could stumble over them, for instance, and easily damage them. Additionally, if these lines are damaged, there could be a risk of electrical shock or short circuit. Set these lines at locations where they will not interfere with customer traffic, or attach covers to them.
- After laying out the power cord on the floor, be sure to always protect it. If the power cord is left exposed, it can easily be damaged, resulting in electrical shock.
- Only use the Power Cords supplied with this product. If a Power Cable is to be replaced, be sure to replace it with one of the same rating and specification.

The AC unit is on the lower back of the Display Cabinet. This AC unit contains the following.

- Main switch
- Inlet for power cable connection
- On/Off Switch
- Circuit protector or Fuse

The accessory power cord has a ground wire inside it.

Connect the power cord to the AC unit then insert the power cord plug into a “power outlet.” Switch the power ON at the power outlet first, then initiate power using the On/Off switch at the AC Unit. Be sure to use a power outlet which is protected by a circuit protector.

1 Confirm that the main switch is at OFF.

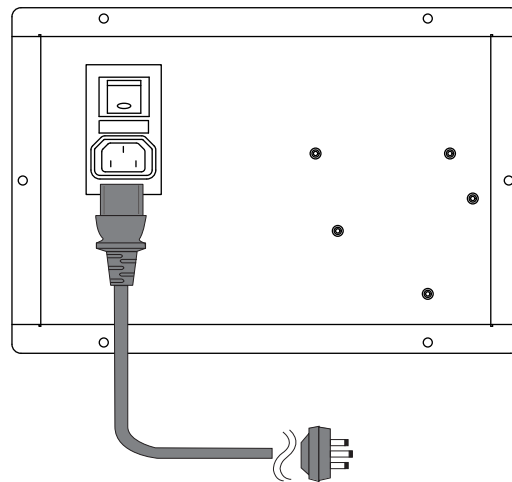
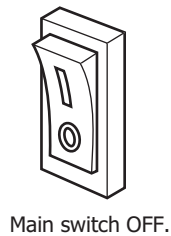

FIG. 6-12b AC Unit

2 Fully insert the power cord connector on the side opposite the power plug into the AC unit inlet.

3 Fully insert the power cord plug into the outlet.

4 The power cord is laid out indoors. Protect the power cord by attaching wire cover to it.

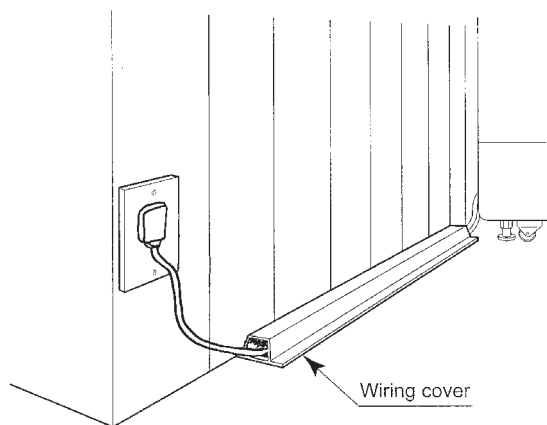

FIG. 6-12c

WARNING

- Be careful not to damage the DVD wire by getting it caught between objects, etc. Doing so may cause a short circuit or fire.
- The following explanation assumes that the product has been assembled properly as explained above. If there is an error or if the product operates in a manner other than as indicated below, cut off the power supply immediately. Failure to do so may result in a fire or electrical shock.
- If you look directly at the laser beam in the DVD DRIVE, you could suffer vision impairment. Do not look inside the DVD DRIVE.

STOP IMPORTANT

- The software is not installed on the game board (LINDBERGH) when the power supply is engaged, so the “Error 22” message is not a malfunction. However, if there is another error display, or if there is no video output at all, there might have been an error in product assembly, wiring connections might be faulty, or the LINDBERGH might not be functioning properly.
- After the power supply is engaged, wait for “Error 22” message to be displayed. If the product is indiscriminately operated in any way beforehand, there could be unexpected problems or malfunctions, as well as damage to parts.
- Once “Error 22” is displayed, set the DVD-ROM in the DVD DRIVE and re-engage the power supply. Installation takes place.
- After the power supply is engaged, the DVD DRIVE tray will not come out for about 30 seconds even if you press the switch. This is due to DVD DRIVE initialization.
- The DVD DRIVE tray can come out or return only while the power supply is engaged. The tray cannot be opened or closed while the power is off.
- Even after the software has been installed, store the DVD software kit, DVD DRIVE and DVD wire in a secure location.
- If for any reason installation cannot be completed, an error is displayed. Refer to the service manual and take corrective action.

Prepare the supplied DVD software kit and the separately sold DVD DRIVE and DVD wire. (See Chapter 5.)

- 1 Before supplying the power, you must make sure the DVD wire is not pinched or trapped.
- 2 Turn the main switch of the AC unit to ON and engage the power supply.
- 3 The LINDBERGH start-up screen appears. Wait for at least one minute. The error state is established. Check to be sure it is “Error 22.” If it is “Error 22,” proceed to the next operation. If it is not “Error 22,” refer to the LINDBERGH Service Manual and take corrective action.

- 4** Take out 1 urea (plastic head) screw and remove the DVD DRIVE case lid.

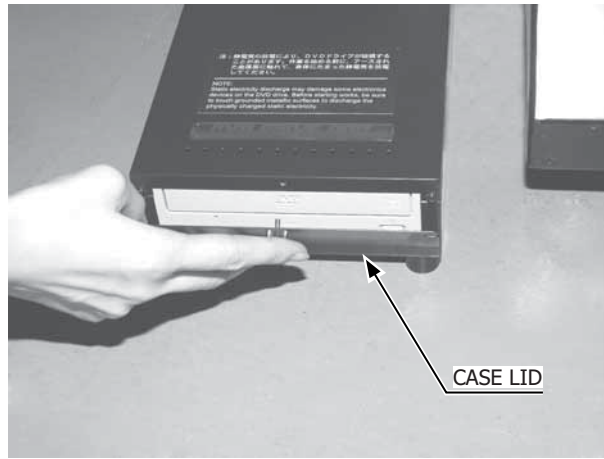

FIG. 6-13a

- 5** Press the DVD DRIVE switch and the DVD DRIVE tray will come out. Set the DVD from the DVD software kit into the tray. Always have the labeled side facing upward.

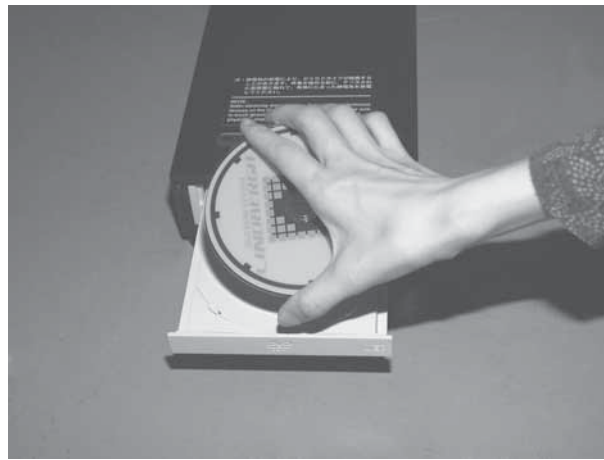

FIG. 6-13b

- 6** Press the DVD DRIVE switch. The tray goes back into the drive.
- 7** Re-engage the power. Turn the main switch to OFF once, wait for at least one minute, then turn the switch back to ON.
- 8** Software is installed automatically from the DVD to the LINDBERGH. In some cases, it may take about 5 minutes to install software to the LINDBERGH.
- 9** Initialization is completed when the Attract Mode screen appears.
- 10** Press the DVD DRIVE switch so that the tray comes out. Remove the DVD.
- 11** Press the DVD DRIVE switch so that the tray goes back into the unit. If the power is cut off, the tray will not move.
- 12** Set the main switch to OFF.
- 13** Remove the DVD wire from the DVD DRIVE.

14 Attach the DVD DRIVE case lid and fasten it with 1 urea screw.

15 Unlock and remove front door PCB.

16 Remove the DVD wire from the LINDBERGH. Leave the key chip inserted.

17 Attach the outlet plate to front door PCB. Fasten with 2 truss screws.

18 Attach and lock front door PCB.

19 Store the DVD DRIVE, DVD wire and DVD software kit in a location free of dust and cigarette smoke.

Process for Turning on the Power

Set the main switch of the AC unit to ON and engage the power.

When you turn on the power, the one billboard fluorescent light and two fluorescent bulbs on the ceiling of the Main Cabinet will come on.

After the LINDBERGH start up screen is displayed on the projector screen, the Advertise (Attract) Mode will start. During Attract Mode, demo footage and how to play the game will be displayed on the screen.

Sound will be emitted from the left and right speakers inside the Main Cabinet and the speaker in the center of the control panel.

If the unit is set for no sound during Attract Mode, there is no sound output.

If there are enough credits to enable play, the start button flashes. It goes out if there are no credits during Attract Mode.

Even when the power source has been cut off, credit count and ranking data are kept stored in the product. However, fractional coin counts (inserted coins that do not amount to one credit) and bonus adder counts are not kept.

7 CONFIRMATION OF ASSEMBLY

Use test mode to confirm that assembly is proper, and that the LINDBERGH, connecting boards, and input/output devices are normal.

Perform the following tests in test mode.

For tests (1) to (4), refer to the LINDBERGH Service Manual. For tests (5) to (7), see [9-3 Game Test Mode].

1 Information Display Screen

When “SYSTEM INFORMATION,” “STORAGE INFORMATION,” or “JVS TEST” has been selected on the system test mode menu, system information, game information and information on JVS I/O board connected to LINDBERGH are displayed.

If each category of information is displayed without anomalies, the LINDBERGH is normal.

2 JVS Input Test Screen

When “INPUT TEST” has been selected on the JVS test screen, data input to the JVS I/O board is displayed. On the product, this is the screen for the testing coin switch.

Insert a coin. If the display to the side of the switch changes, the switch and wiring connections are normal.

3 Monitor Test Screen

When “MONITOR TEST” has been selected on the system test mode menu, the screen for checking projector (monitor) adjustment status appears.

Projector adjustment is completed when the product is shipped from the factory, but you should observe the test screen to determine whether further adjustment is necessary. Refer to Chapter 10 and adjust the projector if necessary.

4 Speaker Test Screen

When “SPEAKER TEST” has been selected on the system test mode menu, the screen for checking speaker sound output appears.

To confirm that audio output is normal, have test sound output from the game unit’s speaker.

5 Input Test

When “INPUT TEST” has been selected on the game test mode menu, the screen for testing input device appears. Test operate the input device by pressing each switch. If the display on the side of each input device changes to “ON” and numerical values change smoothly in accordance with each operation, the input device and its wiring connections are normal. (See 9-3a.)

INPUT TEST		
PLAYER	1	2
TRIGGER	OFF	OFF
ACTION	OFF	OFF
CHANGE	OFF	OFF
GUN-X	000	000
GUN-Y	000	000
SCREEN	OUT	OUT
START	OFF	OFF
SERVICE TEST		OFF OFF
PRESS TEST AND SERVICE BUTTON TO EXIT		

FIG. 6-14a INPUT TEST Screen

6 Output Test

When “OUTPUT TEST” has been selected on the game test mode menu, the screen for testing lamps and other output devices appears.

If each output device operates properly, the output device and its wiring connections are normal. (See 9-3b.)

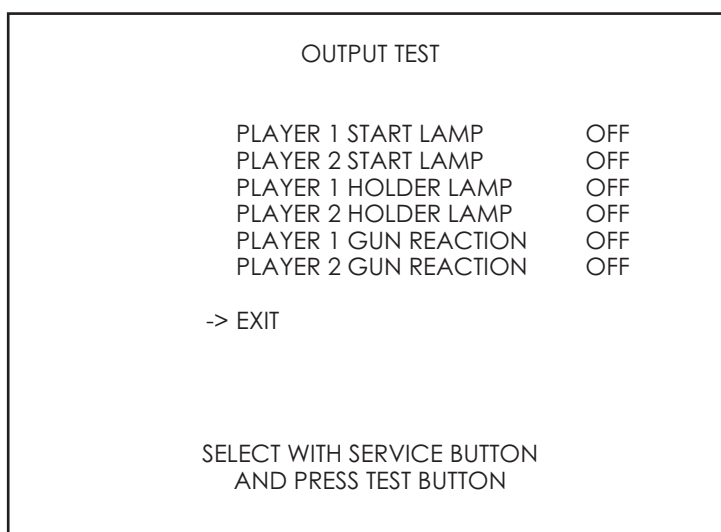

FIG. 6-14b OUTPUT TEST Screen

7 Calibration

Confirm that the operability of control unit do not present any hindrances to play. Calibration is adjusted when the product is shipped from the factory but it might need to be adjusted again because of vibrations during transport, etc.

If such things as operability are not satisfactory, select “GUN CALIBRATION” on the game test mode menu and check and adjust settings. (See 9-3c.)

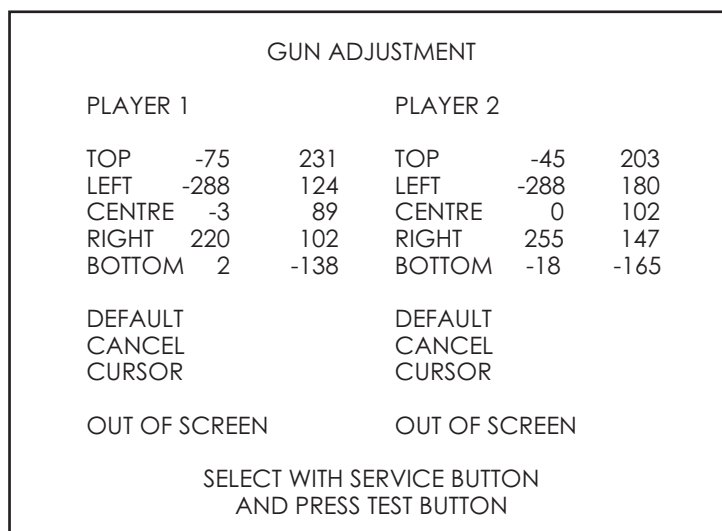

FIG. 6-14c GUN CALIBRATION Screen

Conduct the aforesaid tests when performing routine tests each month.

7 PRECAUTIONS WHEN MOVING THE MACHINE

7-1 MOVING THE MACHINE

WARNING

- Always disconnect the power cable before moving the product. If it is moved with the power cable connected, the cable could be damaged, causing fire or electric shock.
- To move the unit over the floor, pull in the adjustors and have the casters contact the floor. While moving the unit, be careful that the casters do not roll over the power cord or the ground wire. If cord or wire is damaged, there could be electrical shocks and/or short circuits.
- When crossing a sloped or stepped area, disconnect the PTV from the Main Cabinet. If you tilt them while connected together, the connection points may be damaged and personnel could be injured.
- When lifting the cabinet up steps, you must hold it by the designated handles or by the bottom surface. Lifting it by any other area may lead to damage or disfiguration to that part or surrounding parts due to the weight of the cabinet and could also lead to injury of personnel.
- When tilting the cabinet to move it across a sloped or stepped area, always use at least two people. Attempting such an operation alone can lead to accident or injury.
- When moving the components separately, take care concerning the direction you push the DLP and Seat Cabinet in. These elements may fall over, causing damage or an accident.

CAUTION

- When moving the components do not push any of the plastic elements or shaped parts. Do not use them to pull the components along either. This may damage the parts or the surrounding parts and this could lead to accidents or injury.
- After dividing the components to move them, do not use the Control Units in the Main Cabinet to push or pull the cabinet. This may damage or disfigure these parts and lead to malfunctions or injury.
- Do not use the Controller Holders to move the cabinet, in doing so may damage or disfigure them..

STOP IMPORTANT

- When moving the cabinet, do not hold, push or pull the Control Units. This may disfigure or damage them.
- If you need to move components through a narrow or low door and the only way to get the separated components through is to turn them on their side, or if a separation method other than those described in this manual is required, either make a request to the office listed in this document or the place of purchase to perform the operation or contact them regarding how to perform it. Carelessly turning the components onto their side or separating them in ways other than those depicted in this manual may lead to unrepairable damage.
- Do not press the projector screen. The screen can be easily damaged and cannot be repaired if it is, meaning complete replacement will be necessary.

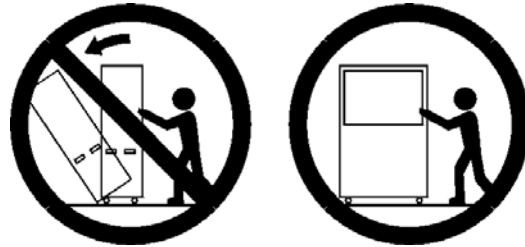

FIG. 7-1a

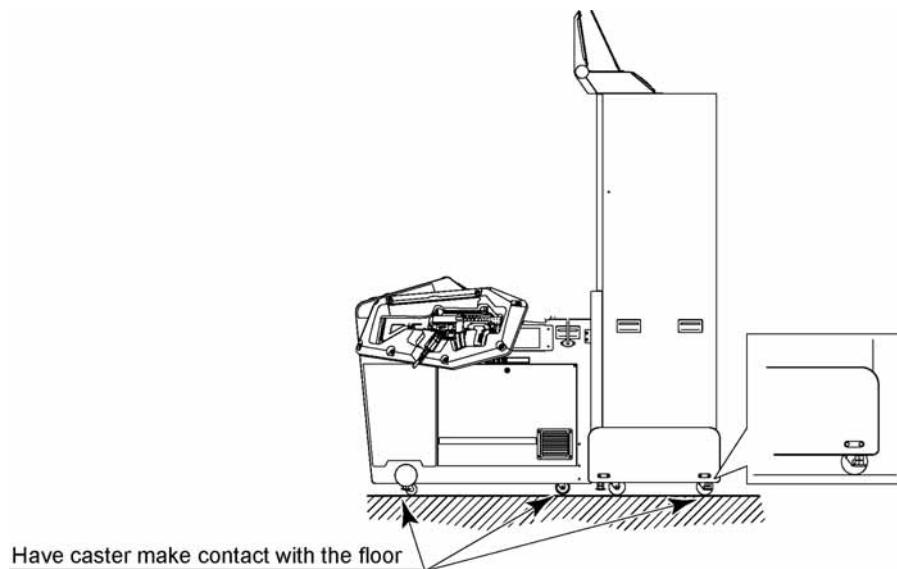

FIG. 7-1b

7-2 SEPARATING THE MAIN CABINET

⚠ WARNING

- Do not carelessly separate the components of the Main Cabinet. This may lead to accidents during maintenance and electric shocks or short circuits during operation.
- After separation of the Gun cabinet from the PTV cabinet, take care which places you push or pull. Do not turn the components onto their sides. This may lead to disfigurement or damage and could cause accidents during maintenance. It could even lead to unreparable damage.

⚠ CAUTION

- To work safely and precisely prepare a steady, safety stool or ladder to stand on. Climbing onto the cabinet or hanging down from it can lead to accidents.
- Perform the separation operation with at least two people. Performing the operation alone could lead to an accident.

STOP IMPORTANT

If the only way to get the separated components into a desired location is to turn them onto their side, or if a separation method other than those described in this manual is required, contact the office listed in this document or the place of purchase. Turning the components onto their side may disfigure or misalign the cabinet and could lead to unreparable damage.

Handles are provided to ease positioning/re-positioning. Please use these handles. Never move the PTV cabinet by pushing the screen. Pushing the screen can result in damage.

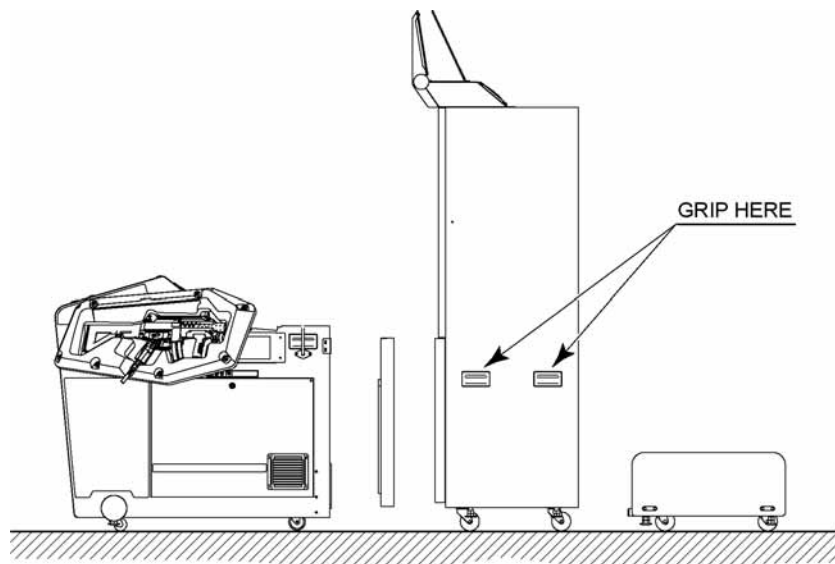

FIG. 7-2a

STOP IMPORTANT

- When transporting the machine, do not push or pull on any plastic or fragile parts. Trying to move the machine by pulling on these parts may cause damage.

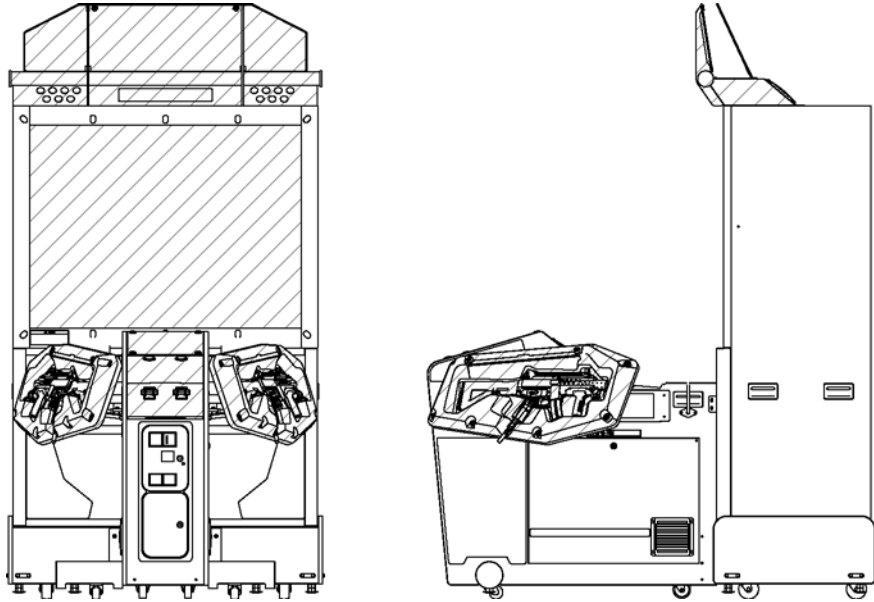

FIG. 7-2b

Do not attempt to move the product by pressing on the shaded areas, in doing so may cause damage to the product.

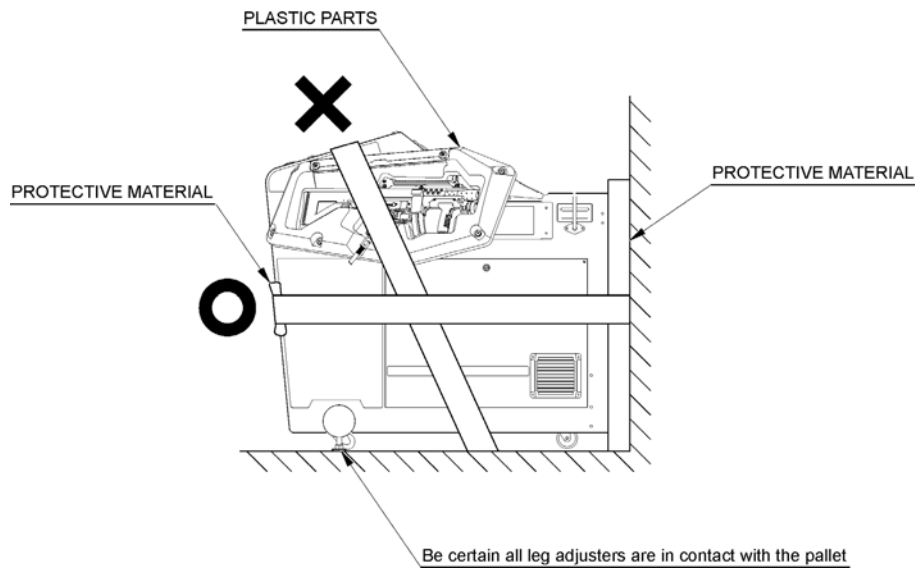

FIG. 7-2c

8 GAME DESCRIPTION

Use this section to confirm the machine is operating correctly; if the machine doesn't operate as described there may be a fault.

While power is connected, the billboard is continuously lit and demonstration footage and ranking data are displayed on screen. This "advertise" mode will be accompanied by sound from both speakers unless set otherwise in test mode.

The 1P and 2P start buttons have integral lights that will flash when a credit is available.

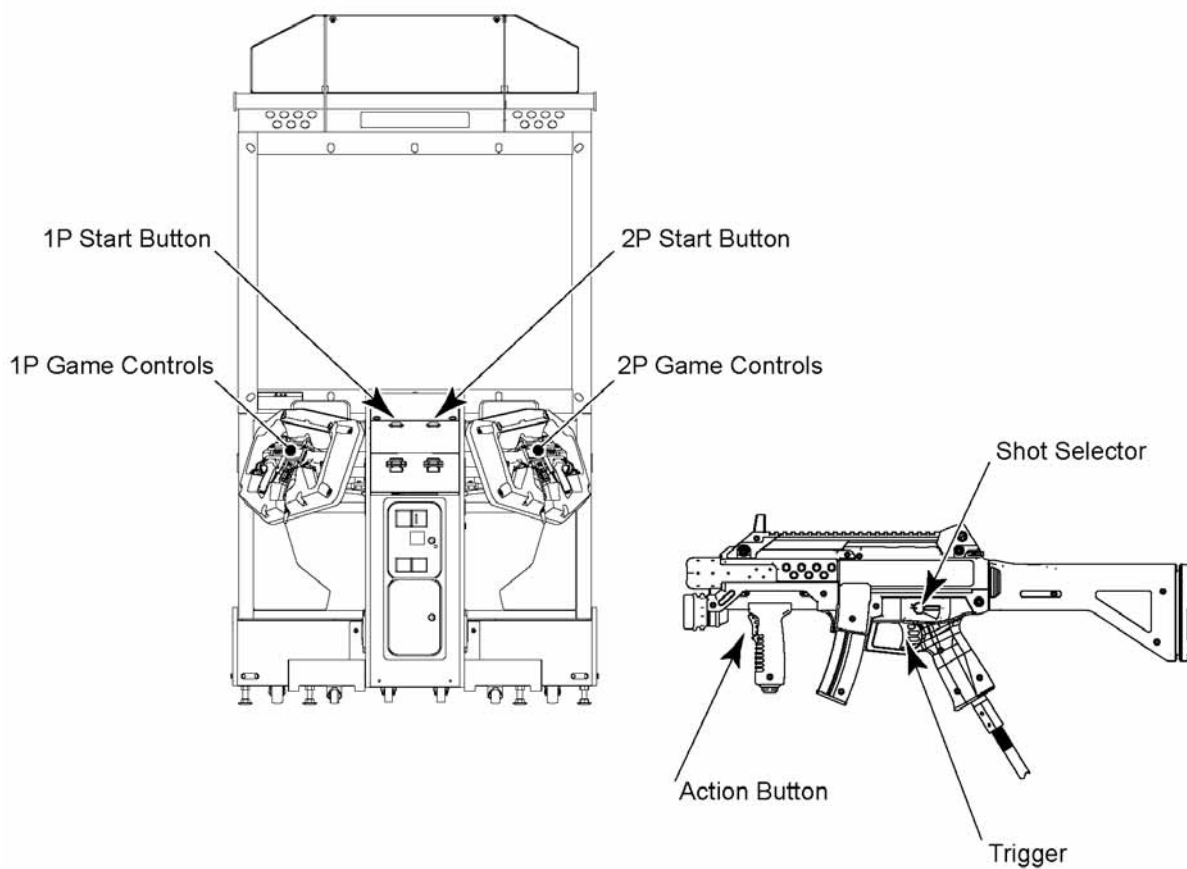

FIG. 8a

Game Outline

The player is a member of the special forces “Ghost Squad”, out to suppress vicious terrorists. Each mission contains multiple routes, allowing the payer to choose how to proceed. Special events occur throughtout the game depending on the route chosen, such as securing hostages or providing friendly cover fire.

Game Controls

the game is controlled with the cabinet START buttons and the provided sub-machinegun style controllers. Each gun controller is equipped with 3 buttons, the TRIGGER, ACTION and SHOT SELECTOR buttons.

START BUTTON	: Used for starting the game and skipping event descriptions.
TRIGGER	: Used for firing (shooting bullets) and penel selection.
ACTION BUTTON	: Used during events and for skipping demo scenes.
SHOT SELECTOR	: Used to switch between firing modes (single shot, 3-shot bursts, full auto).

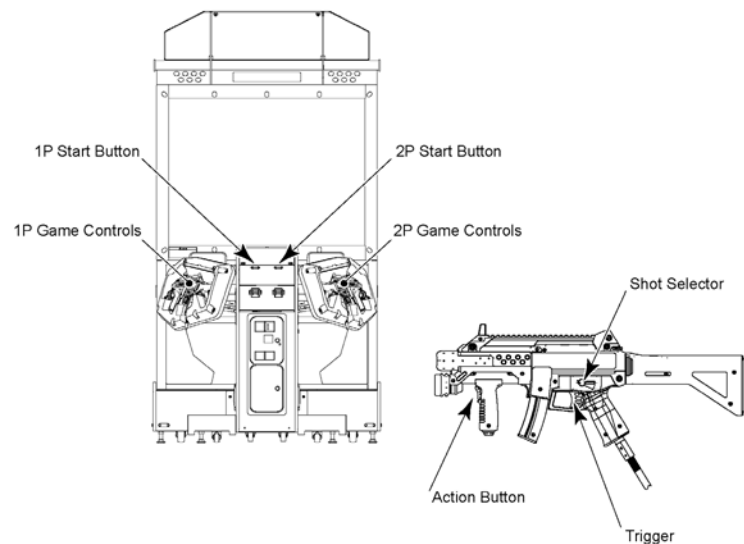

FIG. 8b Game controls

Characters

Alpha Unit

The Alpha Unit are the main characters in the game and are young hot-shot members of “Ghost Squad”, an unofficial unit of the anti-terrorist group, “M.O.P.” (Multi-Operation-Program).



FIG. 8c Alpha Unit

Fellow M.O.P. Members

The Commander provides radio backup and pertinent advice to the Alpha Unit.

Also assisting the Alpha Unit in operations are Bravo Unit and Charlie Unit. These two units assist the players in suppressing the terrorist threat.



Commander
FIG. 8d



Unit Bravo
FIG. 8e



Unit Charlie
FIG. 8f

Customize Screen

Starting the game will display the following screen and allow weapon and cosume selection.



FIG. 8g

Name Entry Screen

Choose a name to represent your character. This name will be used to display the score if it is made into the cabinet ranking.



FIG. 8h

- A) Character scroll buttons.
Scroll through selectable characters (letters). Rapid scrolling is possible by keeping the button held down.
- B) Selectable Characters.
Line up the cursor and pull the trigger to select the character.
- C) Current Character Type.
Displays the current name entry character type.
- D) Character Change Button.
Changes the character type.
- E) Space Button.
- F) Backspace Button
- G) End Button
Sets the entered name.
- H) Name as Entered.
- I) Remaining Time.
The currently entered name is used if the remaning time reaches zero.

Names up to 16 characters in lenght can be entered, using alphanumeric and symbol character types.

Controller Explanation Screen

Exiting the Customize Menu plays the demo which explains how to use the gun controller. This explains the shooting stance, and how to use the SHOT SELECTOR and ACTION button. It is possible to skip this explanation screen with the START button.



FIG. 8i - Gun Controller Explanation Screen

Calibration Screen

If the CALIBRATION setting in the game Test Mode is turned ON, this screen will be displayed before the start of each game.

Holding the gun controller correctly, aim at the target bulls-eye and pull the trigger to calibrate the gun. Press the START button to exit the calibration screen without waiting for the time to expire.

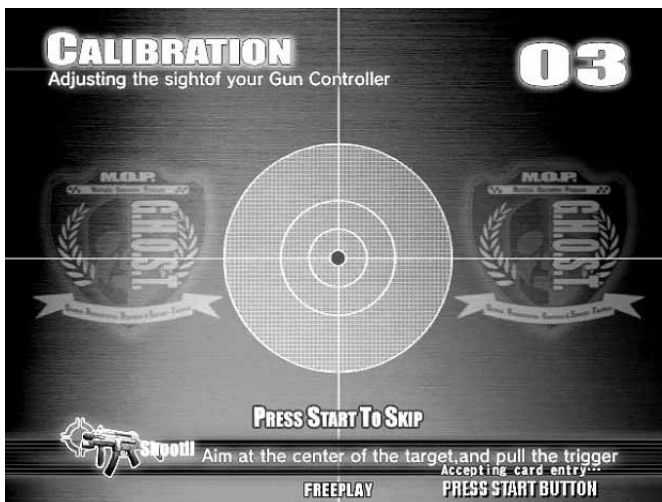

FIG. 8j - Gun Calibration Screen

Mission Selection Screen

On this screen the player selects which mission to play from 3 available missions.

Playing one mission all the way to the end displays the screen shown below, allowing the player to select another mission.

A mission played once cannot be played again in the same game.



FIG. 8k - Mission Selection Screen

The Mission level is displayed on the Mission Select Screen. To play a specific level, line up the cursor with the mission level display and push the ACTION button. By changing the level, it is possible to play at the desired level.

Mission level 1 to 16 can be selected from the beginning.

In-Game Display



FIG. 81 - In-Game Display

- | | | |
|----|-------------------------|--|
| A) | Life (remaining health) | The colour will grow red as it nears zero. |
| B) | GS Meter | Special Points accumulated during the game are shown here. |
| C) | Not Used | |
| D) | Score | Point accumulated during play. |
| E) | Mission Level | Level of current mission. |
| F) | Terrorist | Find and suppress! |
| G) | Fellow Troops | Members of the "Ghost Squad". |
| H) | Correspondence | Support requests from fellow troops, or advice from the Commander appears here. |
| I) | Firing Mode | Selectable firing modes and the current selected firing mode are displayed here. |
| J) | Weapon Information | Equipped weapon and remaining magazine ammunition are displayed. |
| K) | Auxiliary Item | Any current effective auxiliary item are displayed. |

Game rules and Gameplay

Life

During play, the players life is displayed at the top part of the screen.

Life is diminished by enemy attack or accidental fire on hostages.

Once a player's life runs out, play stops.

The amount of life to start a game can be configured in Test Mode settings.

Changing life settings will not effect the length of life gauge. Instead the amount of life lost when receiving damage changes, effectively varying the number of sustainable enemy hits.

(Refer to "LIFE" setting in the GAME ASSIGNMENTS selection of the TEST Menu.

Continue and Game Over

The option to "Continue" is available when the player runs out of life and the life gauge is zeroed.

The START button can be used to continue the game as long as there are credits remaining.

GS Meter

The GS Meter measures the value of the player's special force performance.

For example, pulling off a special shot ("GOOD SHOT", "QUICK SHOT", etc.) or successfully completing an event raises the meter level, while shooting fellow troops or hostages lowers the meter value.

When the GS Meter reaches its maximum level, the current weapon receives an upgrade.

Building up the GS Meter also increases the amount of experience gained following the game.

Reload

When a magazine is empty, reloading is executable by simply aiming the controller outside the screen. At that time it is not necessary to press the trigger or any other buttons. The time it takes between reloading and being able to shoot again varies between weapons.

E-Marker

When discovered, the terrorist commence fire upon the player.

However, not all shots result in injury. An “E-Marker” will be displayed on any enemy whose shot will inflict damage, serving as a warning to the player.

When under fire from multiple enemies, first defeating enemies marked with an “E-Marker” should help the player to avoid damage.

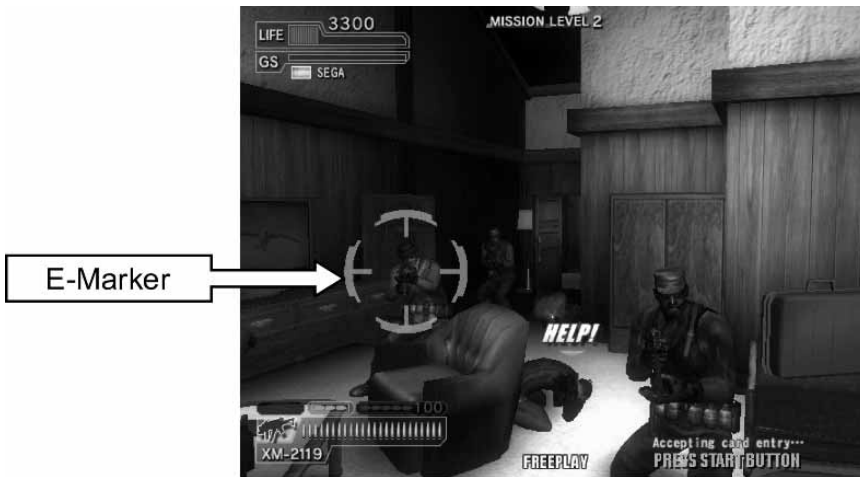

E-Marker

Tactic Selection

Proceeding through the game, “Tactic Selection” panels (as shown below) will appear. The mission route will vary greatly depending on which panel is chosen.



The number of selectable tactics will increase along with the Mission Level.

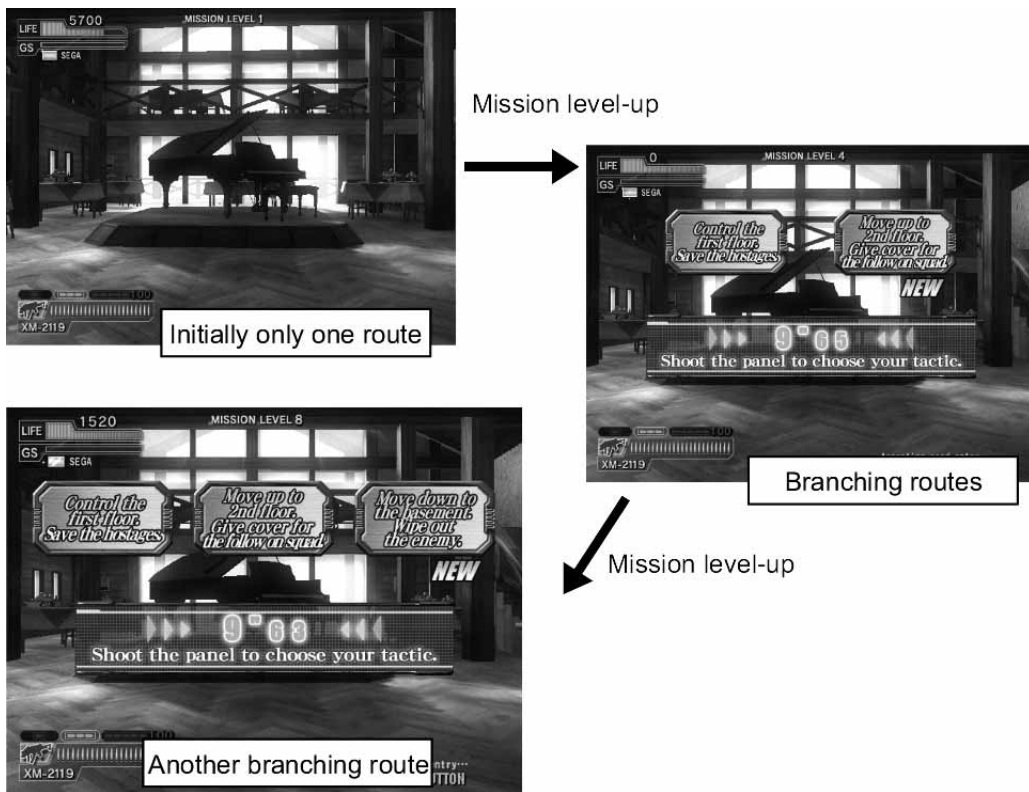

Events (special Operations)

Besides normal terrorist suppression, this game includes additional “events”, such as bomb removal or securing hostages.

If the mission level is high, then a large number of special events become available.

Some events allow use of specialized weapons. For example, when attacking the enemy from a distance in a sniper event, the weapon temporarily changes to a sniper rifle.

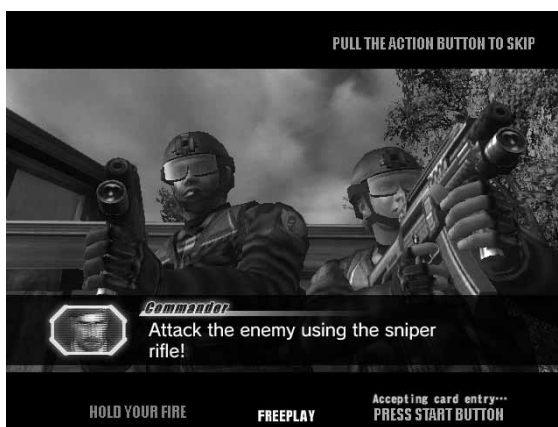

Auxillary Items

Auxillary items appear in certain situations during the game.

There are two types of auxillary items. Items that are put to use and disappear immediately after picking them up, and those that are stocked and continue to be effective over time. The latter type can be used only one at a time.

Some auxillary items can be taken advantage of only when combined with certain weapons.

For example, the “Compensator” is effective only when using weapons that produce a bullet spread effect.

The auxillary items appearing in this game consist of the following 7 types.



First Aid Kit: Restores 1 life unit.



Dot Sight: Displays the gun s sight reticule as an illuminated point.



Hi-cap Magazine: Doubles magazine capacity.



Compensator: Eliminates bullet spread effets.



Body Armour I: Halves the amount of damage taken for up to 2 hits.



Body Armour II: Halves the amount of damage taken for up to 4 hits.



Medal: Increases experience points aquired following the game.

Ranking

The Rank insignia is decided by the players score.

Costumes

This game has a total of 14 costumes.

All 14 costumes will be made available from the start of the game.

The chosen costume can be viewed during the in-cut game scenes. Costumes have no direct effect on damage, score or any other game content.

Examples of Costumes.

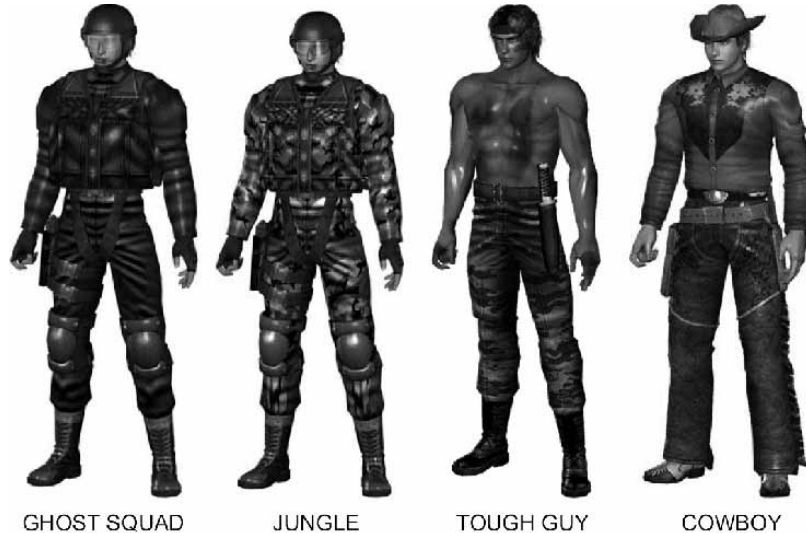

Weapons

The different type of weapons may be selected from the Customize Screen before starting the game. Once equipped, however, a weapon cannot be changed during play.

this game has 25 different types of weapons, each with varying characteristics and auxiliary weapon compatibility.

Machinegun Class: A typical weapon, capable of rapid-fire shooting.

Shotgun Class: Blast covering a wide area, a single shot is capable of taking out many enemies.

Handgun Class: Requires a high learning curve, suitable for expert players.

Rifle Class: Capable of piercing walls and obstacles, can take out hidden enemies.

Others: Weapons not fitting in any of the above categories.

“XM-2119”. A standard sub-machinegun. Can toggle between semi-auto, 3-Shot Burst, and Full-auto firing modes to best match the situation. There is however, an ammunition restriction on Full-auto fire.

“TK1B” A powerful machinegun. It has a high firepower and no Full-auto ammunition restriction. It is also has penetration power, making hidden enemies vulnerable to its fire. Its lack of accuracy from bullet spread is its main weakness, along with a long reload time.

“P44M” Is extremely powerful and capable of penetration.

“M4E”. A shotgun, capable of hitting multiple enemies with a single shot. Despite its power, the danger of hitting hostages or fellow troops with friendly fire warrants caution.

9 EXPLANATION OF TEST AND DATA DISPLAY

WARNING

Do not touch any parts that are not specified in these directions. Touching unspecified locations may lead to electric shock or cause short circuits.

CAUTION

- Be careful that your finger or hand does not get caught when opening/closing the coin chute door.
- Operating the TEST Button and SERVICE Button during Test Mode may be slightly uncomfortable, due to the position of the buttons in relation to the cabinet. Take care not to hurt your shoulder or back, or scratch or catch yourself on any parts of the cabinet.

STOP IMPORTANT

- When you enter the Test Mode, fractional coin and bonus adder data is erased.
- Adjust the sound to the optimum volume, taking into consideration the environmental requirements of the installation location.
- Removing the Coin Meter circuitry renders the game inoperable.
- Have a flashlight on hand and operate in Test Mode very carefully. The cabinet interior is dark and narrow and you could easily make mistakes in operation.

Perform tests and data checks periodically by manipulating the TEST Button and SERVICE Button in the cabinet. Follow the instructions in this chapter to conduct checks when the game machine is first installed, when money is being collected, or when the game machine does not operate properly.

Shown below are the tests and screens to be used for different problems.

This product uses a LINDBERGH game board and a DVD DRIVE. In the system, a different game can be played by putting a different DVD ROM in the DVD DRIVE.

For this reason, the product's Test Mode consists of two modes: a System Test Mode for systems in which coin settings, for instance, are made for products that use the same system, and a Game Test Mode for setting of difficulty level, etc., and for input/output test of operational units used exclusively with this product.

NOTE: "S/M" in the table denotes LINDBERGH service manual, which is provided separately.

TABLE 9

ITEMS	DESCRIPTION	REFERENCE SECTIONS
Game machine installation	1. Confirm that the information display screen appears C in normal fashion.	"S/M" Chapter 4
	2. Investigate each input device on the input test screen.	"S/M" Chapter 4, 9-3a, 9-3c
	3. Investigate each output device on the output test screen.	"S/M" Chapter 4, 9-3b
Periodic maintenance	1. Check settings.	"S/M" Chapter 4, 9-3d
	2. Test each input device on the input test screen.	"S/M" Chapter 4, 9-3a, 9-3c
	3. Test each output device on the output test screen.	"S/M" Chapter 4, 9-3b
Control problem	1. Investigate each input device on the input test screen.	"S/M" Chapter 4, 9-3a, 9-3c
	2. Adjust or replace each input device.	Chapter 11
	3. If the problem persists, examine the mechanical components of each input device.	Chapter 11
Monitor problem	On the monitor adjustment check screen, check to be sure the monitor has been adjusted properly.	"S/M" Chapter 4, Chapter 10
IC board problem	1. Information display screen	"S/M" Chapter 4
	2. Speaker test	"S/M" Chapter 4
Data Check	Check data on game play times, histograms, etc., and adjust the level of difficulty.	9-3e

9-1 VTS Board

VTS Board

To enter in to TEST MODE, open the coin door to reveal the VTS Board. Push the Test button to enter in to TEST MODE.

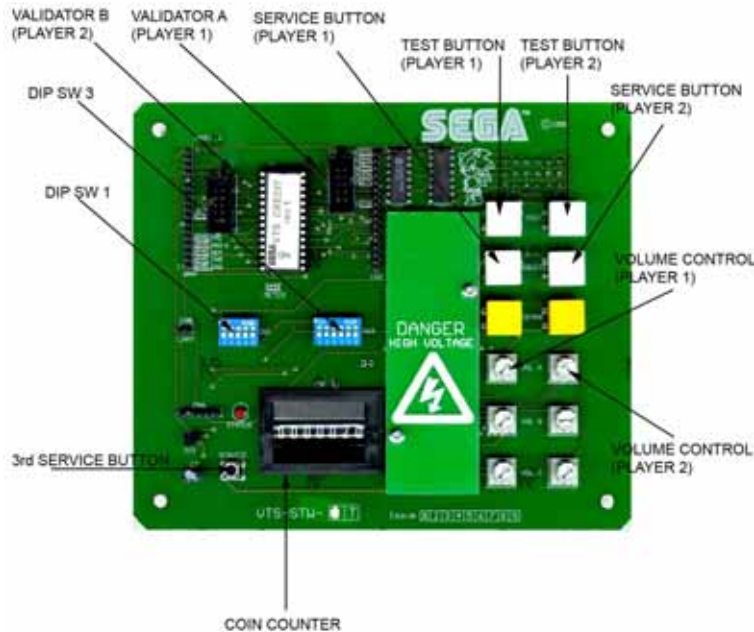

FIG. 9-1a VTS Board

TEST Button (TEST):

Establishes Test Mode. Becomes the button to confirm selections in Test Mode.

SERVICE Button (SERVICE):

Makes it possible to enter credits for service without increasing the coin meter. Becomes the button to select items in Test Mode.

Sound Volume Switch (SP.VOL):

Adjust the volume of the main cabinet left and right speakers, .

Coin Meter

The coin meter is an integral part of the VTS board.

9-2 SYSTEM TEST MODE

STOP IMPORTANT

- The details of changes to Test Mode settings are saved when you exit from Test Mode by selecting EXIT from the system test mode menu. Be careful because if the power is turned off before that point, changes to the settings will be lost.
- Use with the specified settings. If settings other than those specified are used, inappropriate operations or malfunction may occur.

In the system test mode, the main activities include checking LINDBERGH information and actions and the setting of coin/credit. Also, a screen appears for checking screen adjustments. For details, see the LINDBERGH service manual, which is provided separately.

Use the following settings with this product. If the settings are not as specified, error messages might appear and operations might not be normal.

- **COIN ASSIGNMENTS**

COIN CHUTE TYPE: COMMON
SERVICE TYPE (SERVICE Button Type): COMMON

- **NETWORK SETTING**

NETWORK TYPE: MAIN
MAIN NETWORK: Setting Not Required.

- 1 When the TEST Button is pressed, the system test mode menu screen (SYSTEM TEST MENU) appears.
- 2 Use the SERVICE Button to move the cursor to the desired test item.
- 3 Press the TEST Button to confirm selection of the item.
- 4 When testing and checking are completed, select EXIT and press the TEST Button. The SYSTEM TEST MENU screen reappears.
- 5 When all tests are completed, select EXIT and press the TEST Button. The game screen reappears.

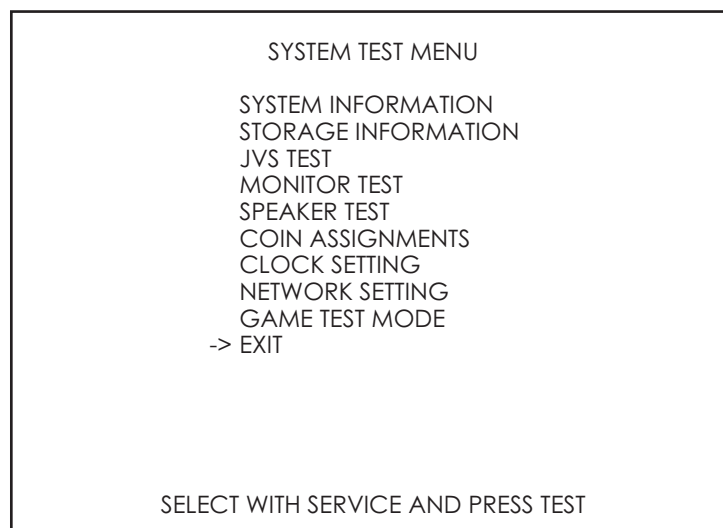

FIG. 9-2 SYSTEM TEST MENU Screen

9-3 GAME TEST MODE

STOP IMPORTANT

To change settings in the game test mode, simply making changes on the setting screen will not be effective. Complete the Test Mode in normal fashion.

Highlight GAME TEST Mode on the system test mode menu, and press the TEST Button to enter the game test mode.

Once you enter the game test mode, the game test mode menu will be displayed.

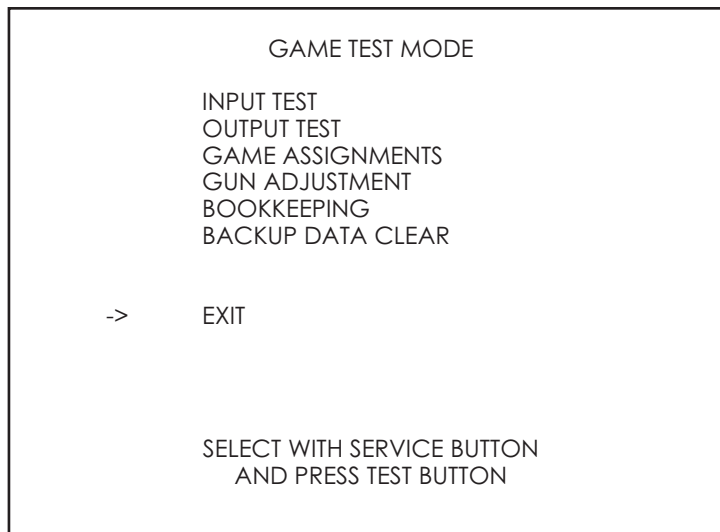

FIG. 9-3a GAME TEST MODE MENU Screen

- 1 Press the SERVICE Button to highlight the desired menu item with the cursor.
- 2 Press the TEST Button to perform the selected item. To learn how to proceed after executing the selected item, read the item's explanation.
- 3 When test or setting is completed, take steps to have the game test mode menu screen reappear. The steps involved vary with the item.
- 4 Select EXIT and press the TEST Button. The system test mode menu screen reappears.
- 5 On the system test mode menu screen, select EXIT and press the TEST Button. The game screen reappears.

<Item Explanation>

INPUT TEST:	Perform an input test.
OUTPUT TEST:	Perform an output test.
GAME ASSIGNMENTS:	Set up game settings.
GUN ADJUSTMENT	Calibrates the controllers
BOOKKEEPING:	View bookkeeping records.
BACKUP DATA CLEAR:	Clear data.
EXIT:	Return to system test mode menu.

9-3a INPUT TEST

INPUT TEST		
PLAYER	1	2
TRIGGER	OFF	OFF
ACTION	OFF	OFF
CHANGE	OFF	OFF
GUN-X	000	000
GUN-Y	000	000
SCREEN	OUT	OUT
START	OFF	OFF
SERVICE		OFF
TEST		OFF
PRESS TEST AND SERVICE BUTTON TO EXIT		

FIG. 9-3a01 INPUT TEST Screen

The condition of each input device can be checked. Periodically check the condition of each input device on this screen.

<Operation>

- 1** Manipulate the control unit (Gun) and confirm that the input value (GUN-X and GUN-Y) on the right side of the item changes smoothly in response to manipulation.
- 2** Manipulate the trigger, action, change and the start buttons and check the display on the right side of the item. The display is normal if it shows ON when trigger or button is pressed and OFF when trigger or button is released.
- 3** Use the TEST Button and SERVICE Button and check the values shown on the right of each category. Operation is normal if it shows ON when pressed and OFF when released.
- 4** When the SERVICE Button and TEST Button are pressed simultaneously, the game test mode menu screen reappears.

<Menu Explanation>

TRIGGER:	Controller trigger
ACTION:	Controller Action button.
CHANGE:	Controller shot selector button.
GUN X:	Control unit left/right input value
GUN Y:	Control unit up/down input value
SCREEN:	Controller Sensor
START BUTTON:	Start button
SERVICE:	SERVICE Button
TEST:	TEST Button

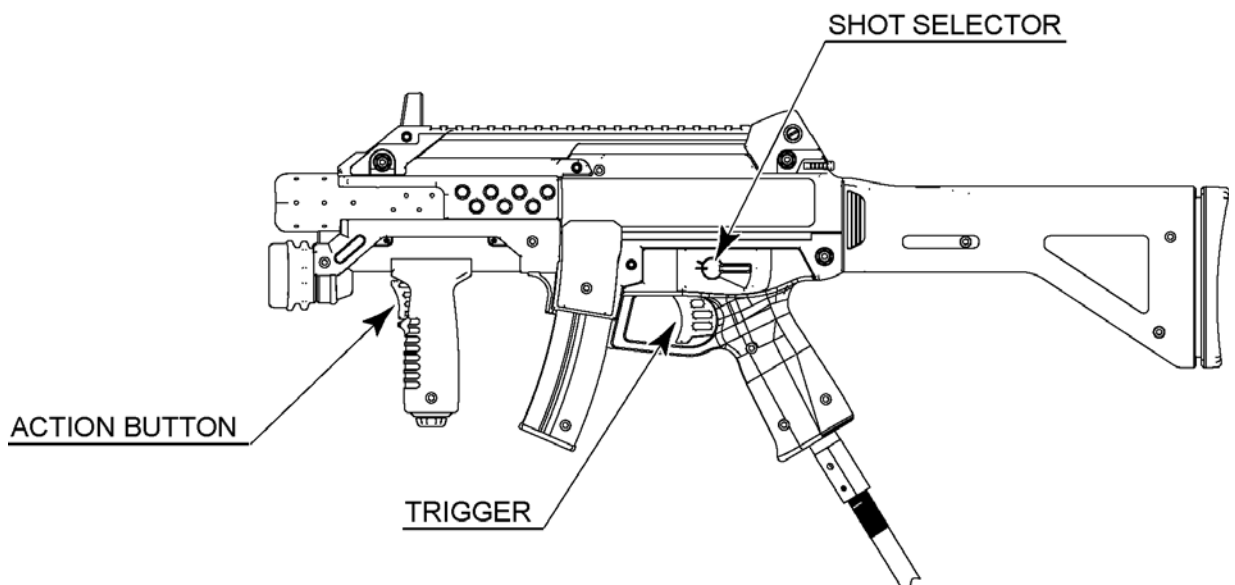

FIG. 9-3a02 Controller

9-3b OUTPUT TEST

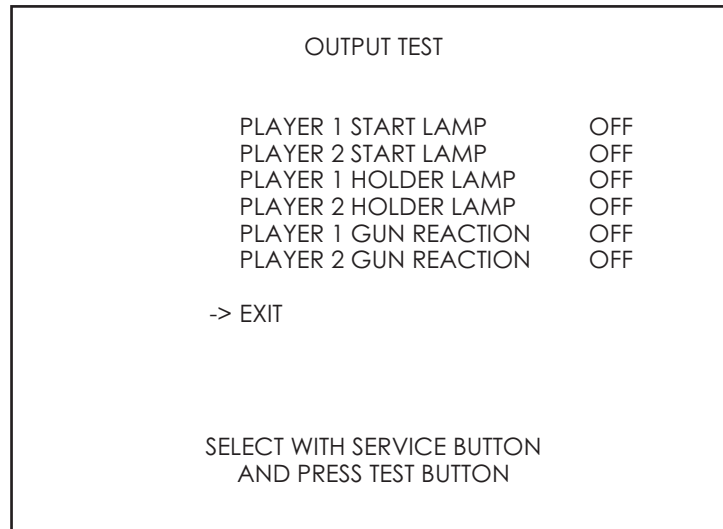

FIG. 9-3b OUTPUT TEST Screen

The condition of each output device can be checked. Periodically check the condition of each output device on this screen. Conditions are normal if each device operates and yields output as indicated below.

<Operation>

- 1** Press the SERVICE Button and move the cursor to the item (output device) you want to test.
- 2** Whenever the TEST Button is pressed, the display on the right side of the item goes from OFF to ON and the selected output device operates. Confirm that the device operates normally.
- 3** Press the SERVICE Button and move the cursor to EXIT.
- 4** When the TEST Button is pressed, the game test mode menu screen reappears.

<Menu Explanation>

PLAYER 1 START LAMP: When ON the player 1 lamp will illuminate.
 PLAYER 2 START LAMP: When ON the player 2 lamp will illuminate.
 PLAYER 1 LAMP HOLDER: When ON the player 1 lamp holder will illuminate.
 PLAYER 2 LAMP HOLDER: When ON the player 2 lamp holder will illuminate.
 PLAYER 1 GUN REACTION: When ON the player 1 gun will rattle.
 PLAYER 2 GUN REACTION: When ON the player 2 gun will rattle.

EXIT: Game Test Menu screen reappears.

9-3c GAME ASSIGNMENTS

STOP IMPORTANT

Setting changes do not become effective until EXIT is selected on the setting screen. After a setting has been changed, be sure to always exit the setting screen.

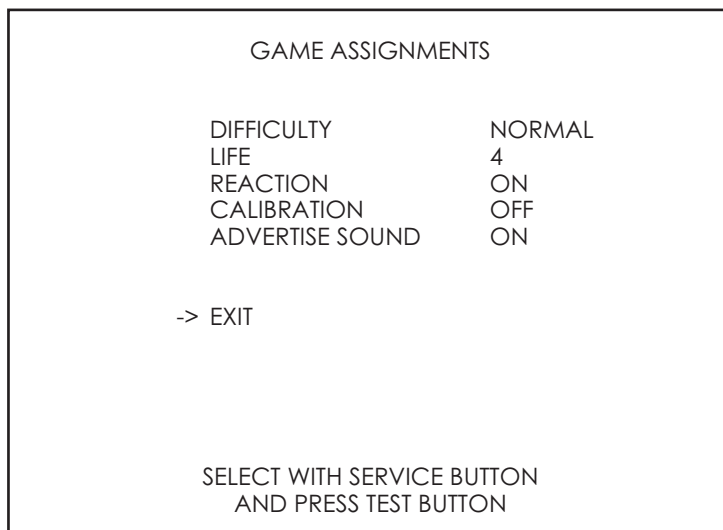

FIG. 9-3d GAME ASSIGNMENTS Screen

The various game settings are established.

<Operation>

- 1 Press the SERVICE Button, move the cursor to the item whose setting is to be changed and select the item.
- 2 When the TEST Button is pressed, the preset value of the selected item changes.
- 3 Press the SERVICE Button and move the cursor to EXIT.
- 4 When the TEST Button is pressed, the game setting screen exits and the game test mode menu screen reappears.

<Menu Explanation>

DIFFICULTY:	Set the difficulty level from EASY, NORMAL or HARD. Default setting is NORMAL
LIFE:	Chose the amount of life given for player starting a new game. If the amount of damage sustained during the game reaches this number then the game is over. Default = 4
REACTION:	Turns the Controllers vibration mode ON/OFF. Default = ON.
CALIBRATION:	Turns the initial gun controller calibration screen ON and OFF. DEFAULT = OFF.
ADVERTISE SOUND:	Turns sound ON/OFF during the attract mode. DEFAULT = ON.
EXIT:	Return to the Game Test Menu screen.

9-3d GUN ADJUSTMENT

STOP IMPORTANT

Calibration is relevant to operability. Manipulate and adjust the control unit to ensure that they are correctly adjusted for game play..

GUN ADJUSTMENT					
PLAYER 1			PLAYER 2		
TOP	-75	231	TOP	-45	203
LEFT	-288	124	LEFT	-288	180
CENTRE	-3	89	CENTRE	0	102
RIGHT	220	102	RIGHT	255	147
BOTTOM	2	-138	BOTTOM	-18	-165
DEFAULT			DEFAULT		
CANCEL			CANCEL		
CURSOR			CURSOR		
OUT OF SCREEN			OUT OF SCREEN		

SELECT WITH SERVICE BUTTON
AND PRESS TEST BUTTON

FIG. 9-3c01 GUN Adjustment Screen

Select GUN ADJUSTMENT to display this screen.

This screen allows you to adjust the five calibration targets (TOP, LEFT, CENTRE, RIGHT and BOTTOM). Use each target to calibrate as follows.

<Operation>

- 1 Aim the controller at the five targets on the screen (Top, Left, Right, Bottom and Centre) and pull the trigger when each target is in view using the controllers aligned sights.
- 2 Once Player 1 controller has been set up, carry out the same operation using the Player 2 controller..
- 3 Move the cursor to EXIT and press the TEST Button, the calibration screen exits and the game test mode menu screen reappears.

9-3e BOOKKEEPING

Displays bookkeeping information across 3 screens.

When the TEST Button is pressed, proceed to the next screen. When the TEST Button is pressed while the (3/3) screen is displayed, the game test mode menu screen reappears.

BOOKKEEPING		1/3
COIN CHUTE #1		0
COIN CHUTE #2		0
TOTAL COINS		0
COIN CREDITS		0
SERVICE CREDITS		0
TOTAL CREDITS		0
PRESS TEST BUTTON TO NEXT		

FIG. 9-3e01 BOOKKEEPING Screen (1/3)

<Menu Explanation>

COIN 1/COIN 2	Number of coins inserted in each coin slot.
TOTAL COINS:	Total number of coins.
COIN CREDITS:	Number of credits awarded from inserting coins.
SERVICE CREDITS:	Number of credits awarded with the SERVICE Button.
TOTAL CREDITS:	Total of COIN CREDITS and SERVICE CREDITS.

BOOKKEEPING		2/3
NUMBER OF GAMES		0
NUMBER OF GAME START		0
NUMBER OF GAMES JOIN		0
NUMBER OF CONTINUE		0
TOTAL TIME		0 D 00 H 00 M 00 S
PLAY TIME		0 D 00 H 00 M 00 S
TOTAL PLAY TIME1P		0 D 00 H 00 M 00 S
TOTAL PLAY TIME2P		0 D 00 H 00 M 00 S
LONGEST PLAY TIME		00 H 00 M 00 S
SHOTEST PLAY TIME		00 H 00 M 00 S
AVERAGE PLAY TIME		00 H 00 M 00 S
PRESS TEST BUTTON TO NEXT		

FIG. 9-3e02 BOOKKEEPING Screen (2/3)

<Menu Explanation>

NUMBER OF GAMES:	Total number of plays on the 1P side and on the 2P side.
NUMBER OF GAME START:	Total number of plays from start on the 1P and 2P side.
NUMBER OF GAMES JOIN:	Total number of plays from join play on the 1P and 2P side.
NUMBER OF CONTINUES:	Total number of continues plays from the 1P and 2P side.
TOTAL TIME:	Total number of hours the power has been supplied. (Time power has been supplied, but not including TEST Mode.)
TOTAL PLAY TIME 1P:	Total play time on the 1P side.
TOTAL PLAY TIME 2P:	Total play time on the 2P side.
AVERAGE PLAY TIME:	Average play time.
LONGEST PLAY TIME:	Longest play time.
SHORTEST PLAY TIME:	Shortest play time.

BOOKKEEPING		3/3
0M 005	~	0M 295 0
0M 305	~	0M 595 0
1M 005	~	1M 295 0
1M 305	~	1M 595 0
2M 005	~	2M 295 0
2M 305	~	2M 595 0
3M 005	~	3M 295 0
3M 305	~	3M 595 0
4M 005	~	4M 295 0
4M 305	~	4M 595 0
5M 005	~	5M 295 0
5M 305	~	5M 595 0
ETC;		
PRESS TEST BUTTON TO NEXT		

FIG. 9-3e03 BOOKKEEPING Screen (3/3)

<Menu Explanation>

1 GAME PLAY TIME: Distribution of playtime for 1 full game (from start until game over).

9-3f BACKUP DATA CLEAR

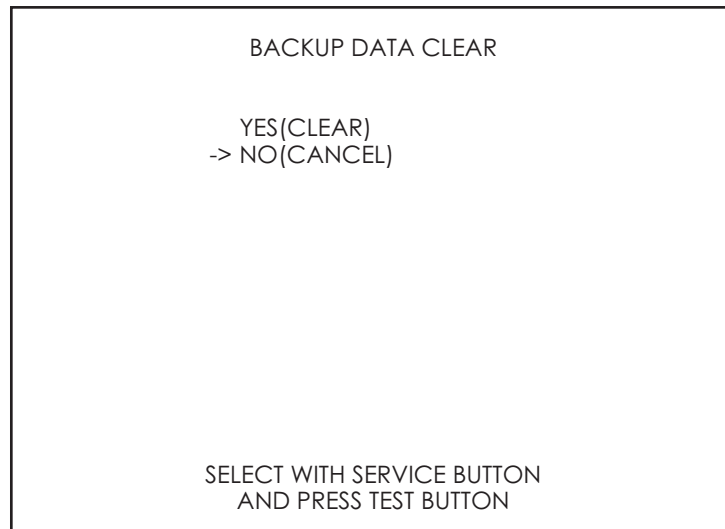

FIG. 9-3f BACKUP DATA CLEAR Screen

- 1** Press the SERVICE Button and move the cursor to the item you want to select.
- 2** To clear data, move the cursor to YES (CLEAR) and then press the TEST Button. When the data has been cleared, the message “COMPLETED” will be displayed and return to the game test mode menu screen automatically.
- 3** Move the cursor to NO (CANCEL) and press the TEST Button to return to the game test mode menu screen without clearing the data.

10 PROJECTOR

⚠ CAUTION

The projector is adjusted prior to leaving the factory. Avoid any unnecessary adjustment.

STOP IMPORTANT

- If the adjustment method in this manual does not resolve the problem contact the customer service number in this manual or your supplier.
- If adjustment to the PTV is necessary, direct the remote control's light emitting portion towards the PTV screen.
- Do not stick tape, stickers or anything else onto the screen. Any kind of adhesive may damage the surface of the screen.
- Since the Projector screen is susceptible to damage, pay careful attention to its handling. When cleaning, refrain from using water or volatile chemicals.
- When the screen surface becomes dirty with dust, etc., clean it by using a soft cloth such as a gauze. When water, and volatile chemicals such as benzene, thinner, etc., spill on the screen surface it may be susceptible to damage, refrain from rubbing them with a hard material or from using a duster.

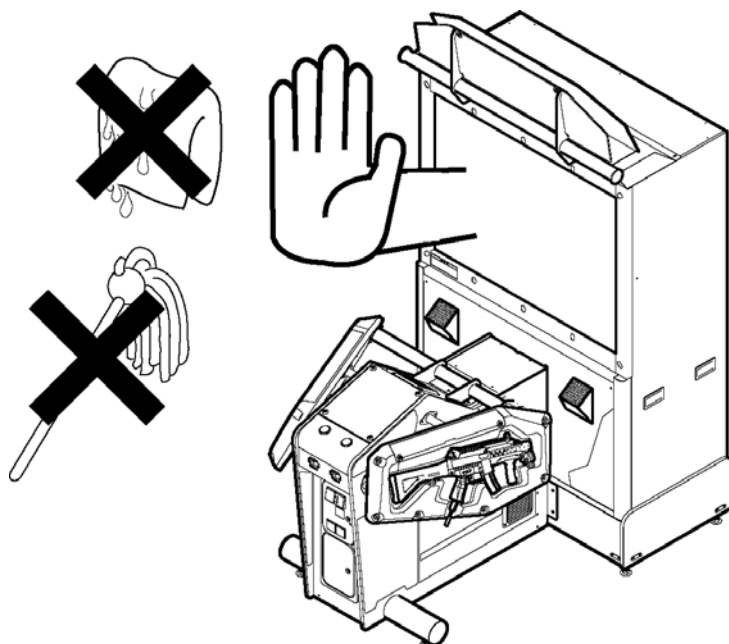
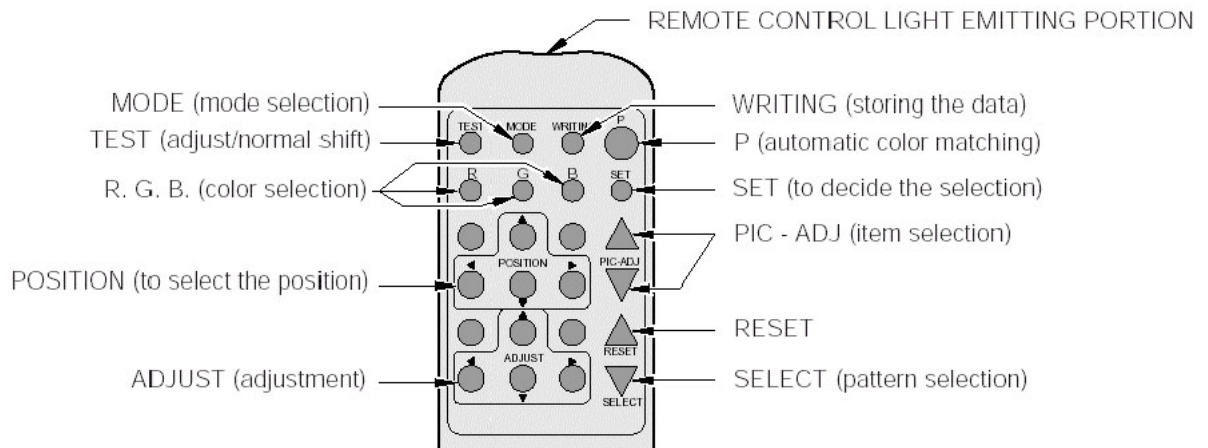

FIG. 10-1

10.1 REMOTE CONTROL BUTTONS

- If adjustment to the PTV is necessary, direct the remote control's light emitting portion towards the PTV screen.



10.2 AUTO COLOUR MATCHING

The Projector may be subject to colour deviations affected by earth magnetism, the building steel frames, etc. When the Projector is initially installed or the Projector's installation position is changed, have the colour matching performed automatically.

Keep pressing the P button (red) for approximately 3 seconds to have the ensuing movements performed automatically.

The Projector will shift to the colour deviation correction mode from the game mode, with the green cross pattern appearing on the screen.

The cross pattern moves up/down and right/left to start the movement of searching the correct screen position and inclination.

When the green cross pattern movements are finished, similar detection is performed sequentially in order of red and then blue cross movements.

After detecting by green, red and blue cross movements, the game mode returns with the colour deviation status being corrected.

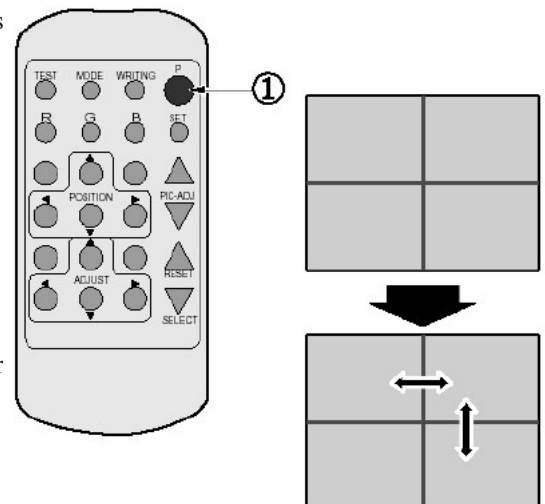

- Although very rarely, the TRY AGAIN error display in red may appear. At this time, press the P button (red) for approximately 3 seconds. Even after the above operation is repeated, if the error condition still exists, then the display shifts to PLEASE ADJ. In this case, the auto colour matching function can not be used. Contact the place of contact herein stated or where the product was purchased from.
- If the automatic colour matching indicates an error, colour matching can manually be performed.
Refer to CONVERGENCE ADJUSTMENT (manual colour matching).

10.3 ADJUSTING ON-SCREEN CONTRAST

- Although the on-screen picture quality has been adjusted at the time of shipment from the factory, the onscreen contrast can be readjusted if desired. When the Game Board is replaced, readjustment may be necessary. Changing the CONTRAST causes the light and shade of the on-screen images to be changed..

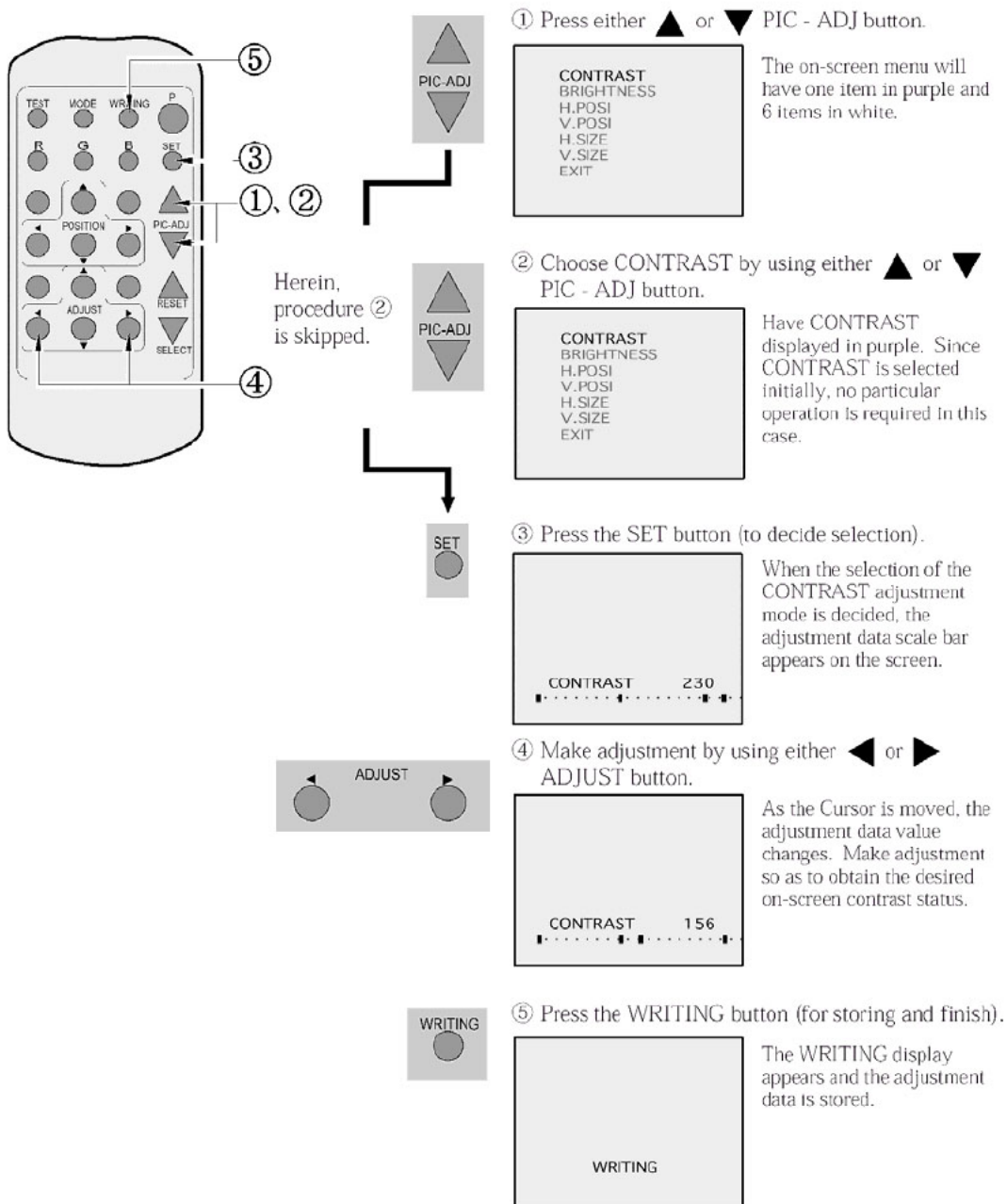

- When discontinuing the adjustment, choose EXIT from the menu at the stage of procedure 2 and press the SET button.
- To continue adjusting other menu items, repeat procedure 2-4.
- Unless the adjustment data is stored, the data in the adjusted status will be erased at the time the power is turned off and the pre-adjustment status will remain when the power is turned on next time.

10.4 ADJUSTING ON-SCREEN BRIGHTNESS

- Although the on-screen picture quality has been adjusted at the time of shipment from the factory, readjustment can be made if desired. When the Game Board is replaced, readjustment may be necessary.

Changing the BRIGHTNESS causes the brightness of the on-screen images of black portions to be changed.

① Press either ▲ or ▼ PIC - ADJ button.

The on-screen menu will have one item in purple and 6 items in white.

```

CONTRAST
BRIGHTNESS
H.POSI
V.POSI
H.SIZE
V.SIZE
EXIT
    
```

② Choose BRIGHTNESS by using either ▲ or ▼ PIC - ADJ button.

Have the BRIGHTNESS displayed in purple.

```

CONTRAST
BRIGHTNESS
H.POSI
V.POSI
H.SIZE
V.SIZE
EXIT
    
```

③ Press the SET button (to decide selection).

When the selection of the BRIGHTNESS adjustment mode is decided, the adjustment data scale bar appears on the screen.

```

BRIGHTNESS 128
┌───────────┴───────────┐
    
```

④ Make adjustment by using either ◀ or ▶ ADJUST button.

As the Cursor is moved, the adjustment data value changes. Make adjustment so as to obtain the desired on-screen brightness status.

```

BRIGHTNESS 156
┌───────────┴───────────┐
    
```

⑤ Press the WRITING button (for storing and finish).

The WRITING display appears and the adjustment data is stored.

```

WRITING
    
```

When discontinuing the adjustment, choose EXIT from the menu at the stage of procedure 2 and press the SET button. To continue adjusting other menu items, repeat procedure 2-4.

Unless the adjustment data is stored, the data in the adjusted status will be erased at the time the power is turned off and the pre-adjustment status will remain when the power is turned on next time.

10.5 ADJUSTING ON-SCREEN DISPLAY POSITION

- Although the on-screen display position (H. POSI, V. POSI) has been adjusted at the time of shipment from the factory, readjustment can be made if desired. When the Game Board is replaced, readjustments may be necessary.

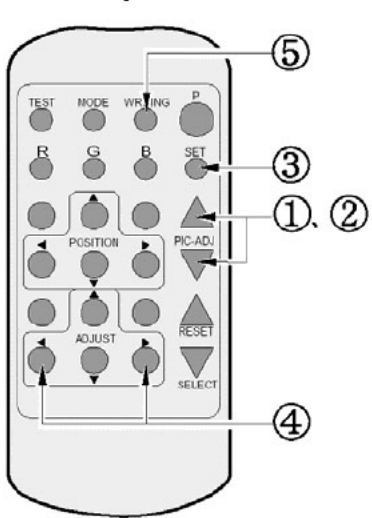

① Press either ▲ or ▼ PIC - ADJ button.

The on-screen menu will have one item in purple and 6 items in white.

```

CONTRAST
BRIGHTNESS
H.POSI
V.POSI
H.SIZE
V.SIZE
EXIT
    
```

② Choose H. POSI or V. POSI by using either ▲ or ▼ PIC - ADJ button.

Have the H. POSI or V. POSI displayed in purple. The Figure shows the status in which H. POSI is selected.

```

CONTRAST
BRIGHTNESS
H.POSI
V.POSI
H.SIZE
V.SIZE
EXIT
    
```

③ Press the SET button (to decide selection).

When the selection of the H. POSI or V. POSI is decided, the adjustment data scale bar appears on the screen.

```

H.POSI 128
┌-----┴-----┐
└-----┬-----┘
    
```

④ Make adjustment by using either ◀ or ▶ ADJUST button.

As the Cursor is moved, the adjustment data value changes. Make adjustment so as to obtain the desired on-screen position status.

```

H.POSI 156
┌-----┴-----┐
└-----┬-----┘
    
```

⑤ Press the WRITING button (for storing and finish).

The WRITING display appears and the adjustment data is stored.

```

WRITING
    
```

When making adjustments in vertical directions, also use either ◀ or ▶ ADJUST button.

- When discontinuing the adjustment, choose EXIT from the menu at the stage of procedure 2 and press the SET button.
- To continue adjusting other menu items, repeat procedure 2-4.
- Unless the adjustment data is stored, the data in the adjusted status will be erased at the time the power is turned off and the pre-adjustment status will remain when the power is turned on next time.

10.6 ADJUSTING THE SCREEN SIZE

- Although the on-screen size (H. SIZE, V. SIZE) has been adjusted at the time of shipment from the factory, readjustment can be made if desired. When the Game Board is replaced, readjustments may be necessary.

① Press either ▲ or ▼ PIC - ADJ button.

The on-screen menu will have one item in purple and 6 items in white.

```

CONTRAST
BRIGHTNESS
H.POSI
V.POSI
H.SIZE
V.SIZE
EXIT
    
```

② Choose H. SIZE or V. SIZE by using either ▲ or ▼ PIC - ADJ button.

Have the H. SIZE or V. SIZE displayed in purple. The Figure shows the status in which H. SIZE is selected.

```

CONTRAST
BRIGHTNESS
H.POSI
V.POSI
H.SIZE
V.SIZE
EXIT
    
```

③ Press the SET button (to decide selection).

When the selection of the H. SIZE or V. SIZE adjustment mode is decided, the adjustment data scale bar appears on the screen.

```

H.SIZE 128
-----
    
```

④ Make adjustment by using either ◀ or ▶ ADJUST button.

As the Cursor is moved, the adjustment data value changes. Make adjustment so as to obtain the desired on-screen position status.

```

H.SIZE 156
-----
    
```

⑤ Press the WRITING button (for storing and finish).

The WRITING display appears and the adjustment data is stored.

```

WRITING
    
```

When making adjustments in vertical directions, also use either ◀ or ▶ button.

- When discontinuing the adjustment, choose EXIT from the menu at the stage of procedure 2 and press the SET button.
- To continue adjusting other menu items, repeat procedure 2-4.
- Unless the adjustment data is stored, the data in the adjusted status will be erased at the time the power is turned off and the pre-adjustment status will remain when the power is turned on next time.

10.7 CONVERGENCE ADJUSTMENT

⚠ CAUTION

- To avoid circuitry malfunctioning due to electrical load increase, never utilize CONVERGENCE ADJUSTMENT (Line Convergence Adjustment in particular) for adjusting screen size changes.

There is no means to restore the Convergence Adjustment data once stored, to its original state. To avoid changing the screen size by erroneously using convergence adjustment, do not perform the green Line Convergence Adjustment. As such, be sure to perform the adjustment work from this page onward by the Technical staff and the Location's Maintenance Man who are well versed in such adjustment work. In the Static Convergence Adjustments, if satisfactory adjustments can not be performed, do not make another convergence adjustments inadvertently.

Contact the office herein stated or where the product was purchased from.

⊘ IMPORTANT

- To avoid making the adjustment work ineffective, do not press the RESET button during adjustment.
- To discontinue adjustment work, keep pressing the TEST button for approximately 3 seconds at the stage before storing the adjustment data by pressing the WRITING button.
- Should the screen be abnormally disturbed by noise due to static electricity, etc., turn the power off without storing the adjustment data.

Pressing the ▲ or ▼ PIC - ADJ button in the Convergence Adjustment mode status will display the Adjustment Menu shown right. Do not utilize this Adjustment Menu as this is the one applied at the factory.

Adjusting this menu causes the Customer's adjustment range to be deviated.

Should the menu shown right be displayed by mistake, first choose EXIT by using either ▲ or ▼ PIC - ADJ button and then press the SET button.

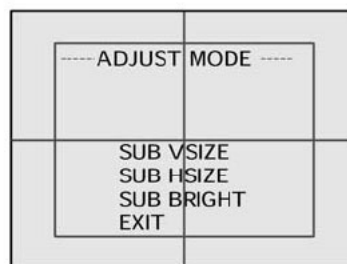

Adjustment menu used in the factory.

10.8 STATIC CONVERGENCE ADJUSTMENT

In the **STATIC CONVERGENCE** adjustment, each of red and blue images is comprehensively moved to and superimposed on the green colour. If automatic colour matching function is not sufficiently satisfactory, perform this adjustment. Be sure to perform automatic colour matching before starting the above adjustment.

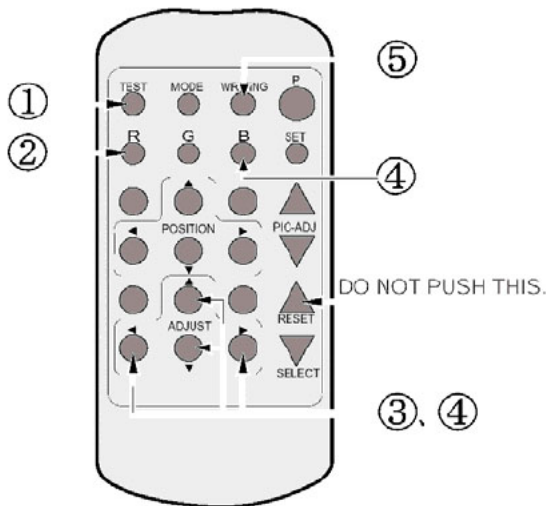

When either of ② ④ COLOR SELECT buttons (R, B) is pressed, if the color desired to be adjusted disappears, press that particular button again. For example, if the red color needs to be adjusted again at the stage of ④, the R button need to be pressed twice.

- ① Keep pressing the TEST button for approximately 3 seconds.

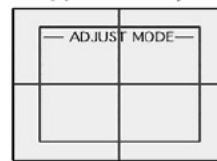

The screen will change to ADJUST MODE from the Game mode to cause the green test pattern to be displayed on the screen.

- ② Press the R button to have the red adjustment mode.

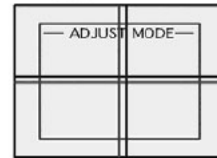

The red test pattern is added to the display. The frame color turns red and this signifies the red adjustment mode.

- ③ Make adjustment by using the ▲ ▼ ◀ ▶ ADJUST buttons.

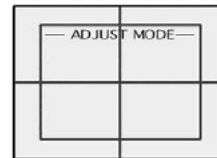

Make adjustment so as to have red superimposed on green. When red is superimposed on green, the color becomes yellow.

- ④ Press the B button to have the blue adjustment mode.

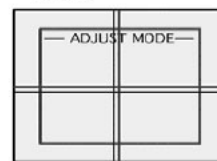

Similarly as in the case of red, adjust the blue color. When green, red, and blue are superimposed, the color becomes white.

- ⑤ Press the WRITING button (for storing and finish).

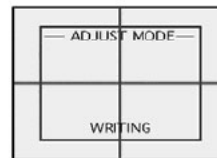

The WRITING display appears and the adjustment data is stored. After the data is stored, the Game mode returns.

10.9 POINT CONVERGENCE ADJUSTMENT

In the POINT CONVERGENCE adjustment, each of red, green and blue images is partially moved for colour matching. The adjustment may be necessary when the Game Board is replaced or changed, or screen size is changed. Be sure to perform automatic colour matching before starting the adjustment.

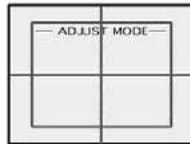
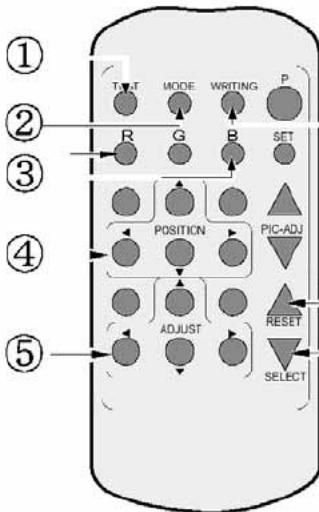

The screen changes to ADJUST MODE from the Game mode and displays the green test pattern.

② Press the MODE button twice to have the POINT ADJUSTMENT mode. (Note 1)

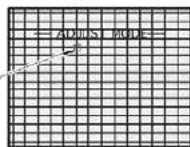

The crosshatch test pattern appears and the MARKER indicating the adjustment point is displayed.

③ Using either R or B button, select the desired color to be adjusted. (Note 2) By using the G button, the green color can also be selected.

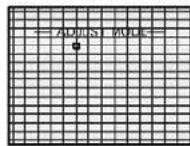

The selected color is displayed by superimposing on green. The MARKER will be in the color selected.

④ By using the ▲ ▼ ◀ ▶ POSITION buttons, move the MARKER to the position to be adjusted.



The MARKER moves in the direction of the button's arrow. However, the movable point is predetermined.

⑤ Make adjustment by using the ▲ ▼ ◀ ▶ ADJUST buttons.



Although the direct vicinity of the MARKER's center moves most conspicuously, make adjustment by paying attention to the periphery area also. Shown left is the magnified MARKER periphery.

⑥ Press the SELECT button as necessary to superimpose Game Board images. (Note 3)

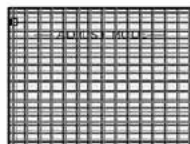

If the test pattern is not displayed in the periphery of the screen, adjustments can be made by pressing the SELECT button to superimpose the test pattern and the Game Board's CRT test screen.

⑦ Press the WRITING button (for storing and finish).

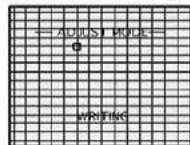

WRITING is displayed and the adjustment data is stored. After the data is stored, the Game Board screen returns.

(Note 1) When the MODE button is repeatedly pressed, the adjustment modes will circulate as follows:



(Note 2) When either of the COLOR SELECT buttons (R, B) is pressed, if the desired color to be adjusted disappears, press that particular button again.

(Note 3) By repeatedly pressing the SELECT button, only the Projector's TEST pattern screen and the screen superimposing the Game Board Test pattern can be alternately displayed.

10.10 LINE CONVERGENCE ADJUSTMENT

In the LINE CONVERGENCE adjustment, the adjustment point of the column line (vertical) or row line (horizontal) is comprehensively moved for colour matching. It is convenient to utilize this adjustment when the colour of the column line or row line is uniformly deviated.

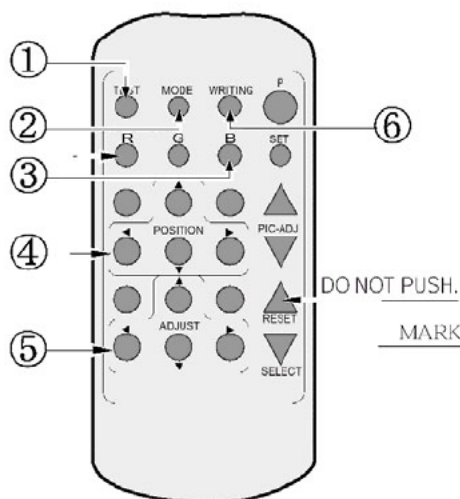

(Note 1) When the MODE button is repeatedly pressed, the adjustment modes will circulate as follows:

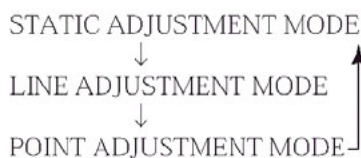

(Note 2) When either of the COLOR SELECT buttons (R, B) is pressed, if the desired color to be adjusted disappears, press that particular button again.

① Keep pressing the TEST button for approximately 3 seconds.

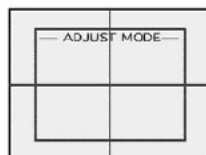

The screen changes to ADJUST MODE from the Game Board mode and displays the green test pattern.

② Press the MODE button once to have the POINT ADJUSTMENT mode. (Note 1)

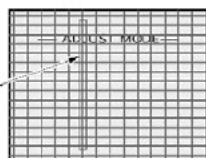

The crosshatch test pattern appears and the vertically long MARKER is shown.

③ Using either R or B button, select the desired color to be adjusted. (Note 2) Although the green color can also be selected by using the G button, to avoid the screen size change adjustment, do not choose green.

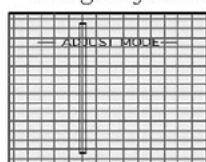

The selected color is displayed by superimposing on green. The MARKER will be in the color selected.

④ By using the ▲ ▼ ◀ ▶ POSITION buttons, move the MARKER to the position to be adjusted.

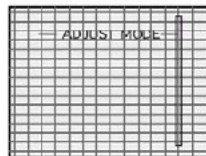

Use the ◀ ▶ buttons to select the column line, and the MARKER moves in the right/left direction. However, the movable range is predetermined.

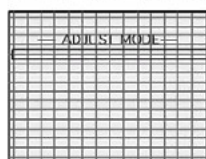

Use the ▲ ▼ buttons to select the row line and the MARKER moves in the up/down direction. However, the movable range is predetermined.

⑤ Make adjustment by using the ▲ ▼ ◀ ▶ ADJUST buttons.

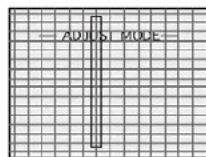

The selected column line or row line (shown left is the column line) can be moved in the desired up/down or right/left directions as applicable.

⑥ Press the WRITING button (for storing and finish).

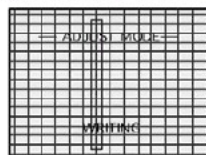

WRITING is displayed and the adjustment data is stored. After the data is stored, the Game Board screen returns.

11 CONTROL UNIT

WARNING

- When working with the product, be sure to turn the power off. Working with the power on may cause an electric shock or short circuit.
- Be careful not to damage the wires. Damaged wires may cause an electric shock, short circuit or present a risk of fire.
- Do not touch any parts that are not specified in these directions. Touching unspecified locations may lead to electric shock or cause short circuits.
- This work should be performed by site maintenance personnel or other skilled professionals. Work performed by non-technical personnel can cause a severe accident such as an electric shock.
- Exercise due caution in performing soldering procedures. If soldering iron is handled carelessly, there could be fires or burns.
- Proceed very carefully when heating thermal contraction tube. Careless operations can result in fires or burns.

CAUTION

- When fastening plastic parts, be careful not to tighten screws and nuts excessively. Otherwise parts may be damaged, resulting in injuries from fragments, etc.
- Be careful not to get hand or finger caught when removing or attaching the parts.
- Disconnection and connection of connectors will be performed within the narrow cabinet space. Take due care not to scratch or otherwise injure yourself.

IMPORTANT

- After adjusting or replacing a microswitch, always check ON/OFF of the switch on the input test screen of the test mode.

If the operability of the Control Unit is unsatisfactory, or if settings on the test mode calibration screen are ineffective, the problem could be a defective mechanism, displacement of the position where sensor or microswitch has been fastened, or malfunctioning of the sensor or microswitch.

Carry out the following procedure to replace Control Unit sensor or microswitch.

11-1 HOW TO REPLACE THE MICROSWITCH

To replace the Gun Controller's internal components, first separate the left shell (Cover L) and right shell (Cover R). The controller's internal components are mounted on the right shell, so work with the gun lying on its right side. To replace the Shot Selector button microswitch, first remove the Shot Selector button from the right shell.

1 Turn off the power.

2 Remove the 15 screws to separate the two shells.



SCREW BLACK (15)
M3 X 12 WSMALL FLAT AND SPRING WASHER

FIG. 11-1a

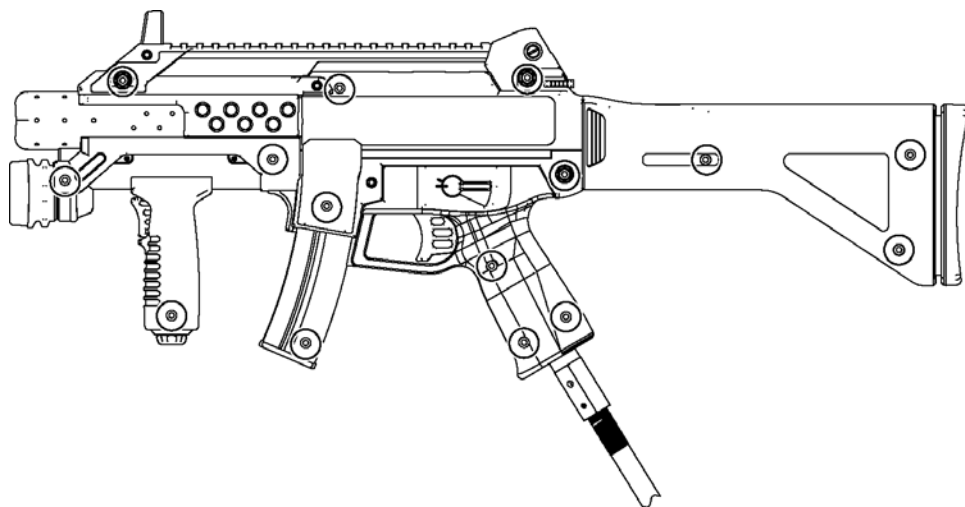

FIG. 11-1b

- 3 With the right side shell lying flat, carefully lift the left shell from the right shell.



FIG. 11-1c

- 4 Remove the microswitch to be replaced from cover R. There are a total of three microswitches.

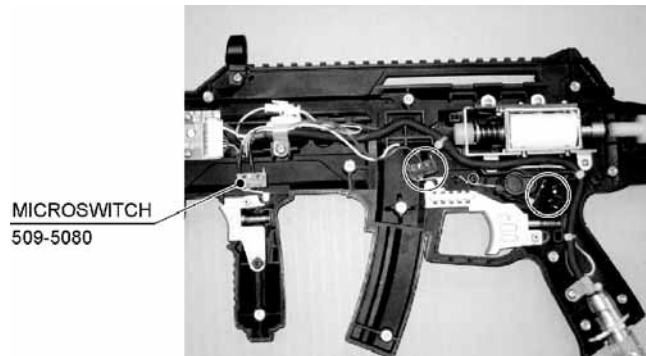

FIG. 11-1d

- 5 Remove the soldering to take out the microswitch.

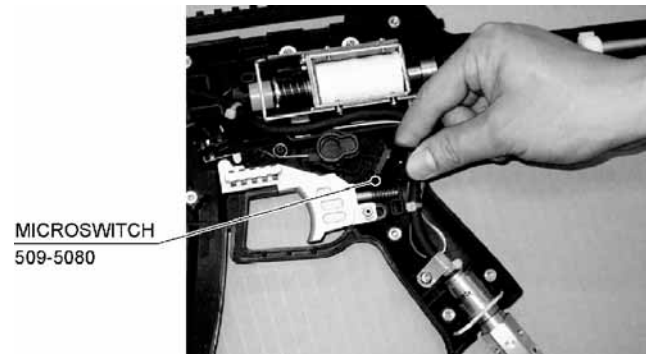

FIG. 11-1e

- 6 Solder the new microswitch in place to reconstruct the gun controller. When performing this step, verify the points listed below before reattaching Cover L and Cover R.

- The wires and connectors are laid out correctly in Cover R.
- The bearing holder is securely in place when the pad assembly spring is compressed.
- The selector is laid out horizontally.
- The selector joint and selector spring are properly set.

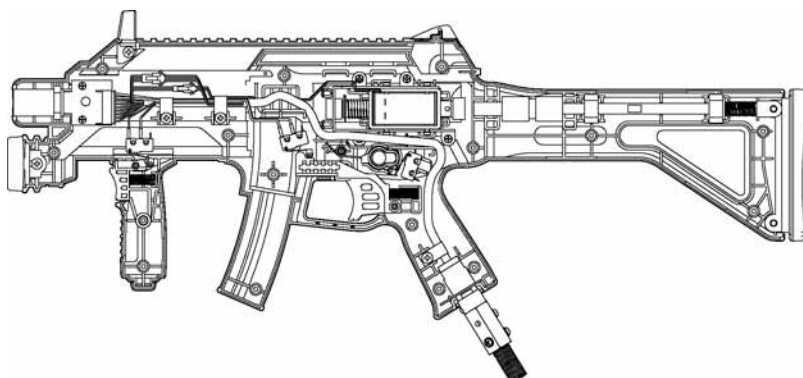

FIG. 11-1f

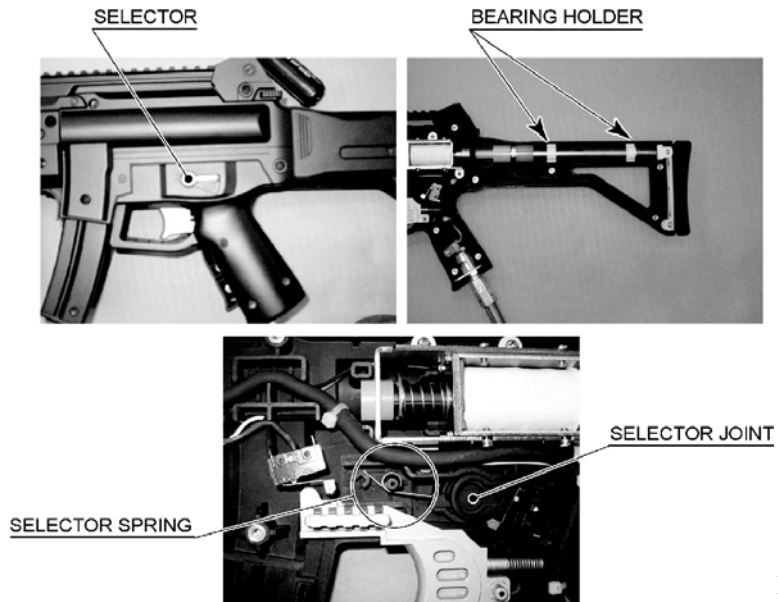

FIG. 11-1g

- 7 Operate the TRIGGER, SHOT SELECTOR and ACTION buttons to make sure that the microswitches turn ON/OFF correctly.

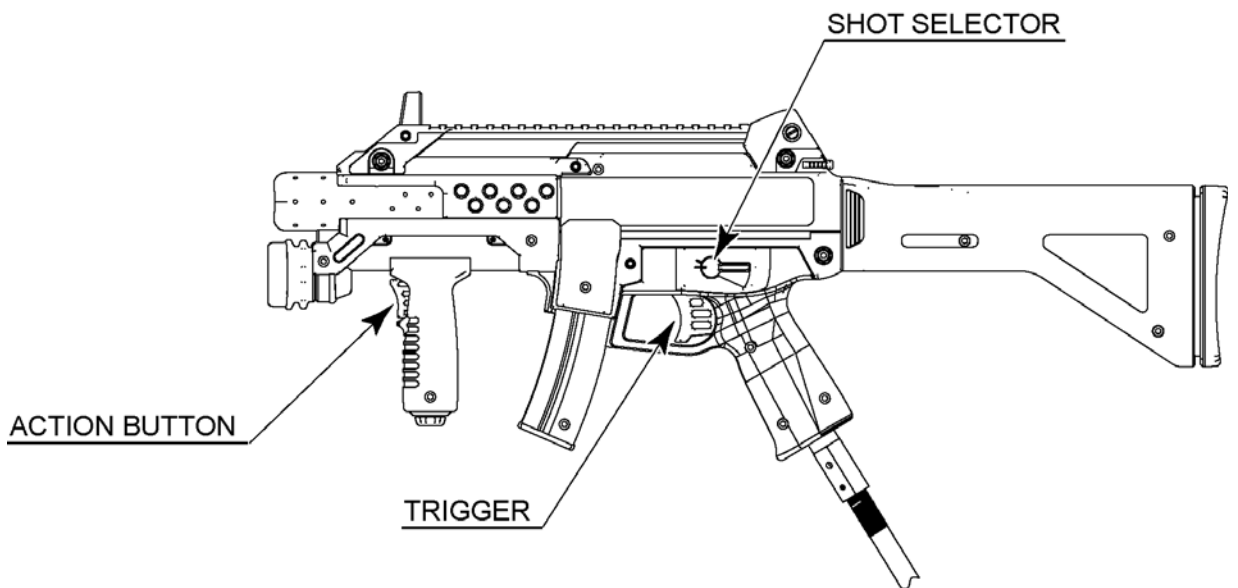

FIG. 11-1h

- 8 After replacement, perform an INPUT TEST, referring to the instruction in the “GAME TEST MODE”

11-2 REPLACING THE SENSOR UNIT

1 Follow the instructions 1 to 3 of “Replacing the Microswitch” to remove the Cover L.

2 Remove the connector to replace the sensor unit.

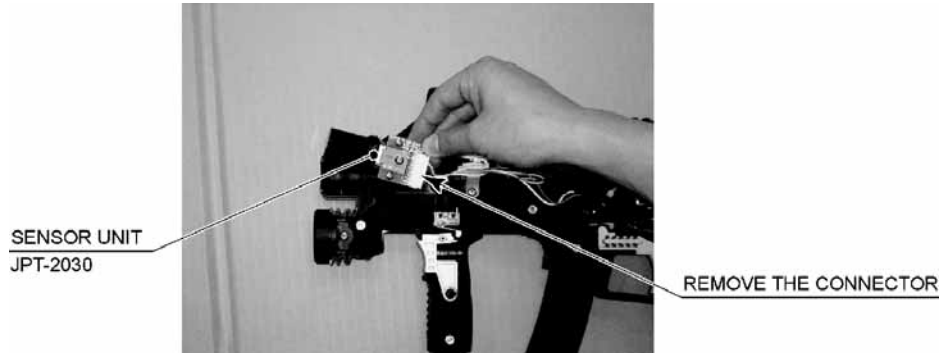

FIG. 11-2a

3 Refer to the previous item, then attach Cover R while being careful of each of the parts.

4 After replacement, perform a GUN ADJUSTMENT, referring to the instructions in “Game Test Mode”

11-3 REPLACING THE SOLENOID

1 Follow the instructions 1 to 3 of “Replacing the Microswitch” to remove the Cover L.

2 Remove the 2 pin connector, wire and 4 screws to remove the solenoid assembly..

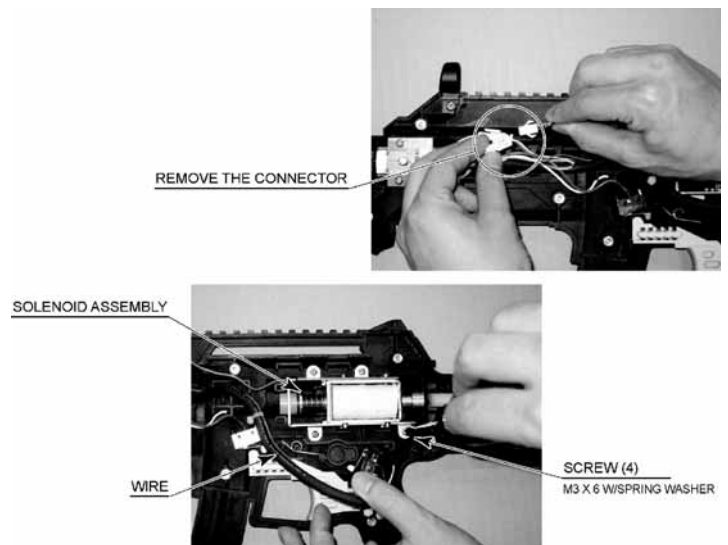

FIG. 11-3a

3 Remove the 8 screws and replace the solenoid.

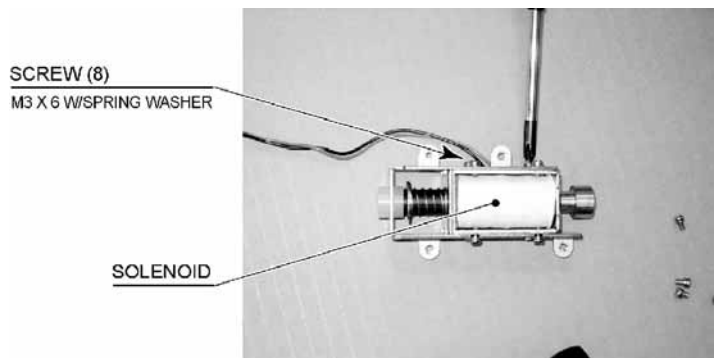

FIG. 11-3b

4 Secure the solenoid assembly with 4 screws and replace the connector. When doing this, make sure not to damage the wiring.

5 Refer to the previous item, then attach the Cover R, while being careful of each of the parts.

6 After replacement, perform an OUTPUT TEST, referring to the instructions in “GAME TEST MODE”.

12 COIN SELECTOR & CREDIT SETTINGS

Handling the Coin Jam

If the coin is not rejected when the REJECT button is pressed, open the coin chute door and open the selector gate. After removing the jammed coin, put a normal coin in and check to see that the selector correctly functions.

Cleaning the Coin Selector

STOP IMPORTANT

- Remove and clean smears by using a soft cloth dipped in water or diluted chemical detergent and then squeezed dry.
- Never apply machine oil, etc. to the Coin Selector.
- After cleaning the Coin Selector, insert a regular coin in the normal working status and ensure that the selector correctly functions.

The Coin Selector should be cleaned once every 3 months. When cleaning, follow the procedure below:

- 1 Turn the power for the machine OFF. Open the coin chute door.
- 2 Remove the Coin Selector from the coin chute door.
- 3 Open the gate and dust off by using a soft brush (made of wool, etc.).

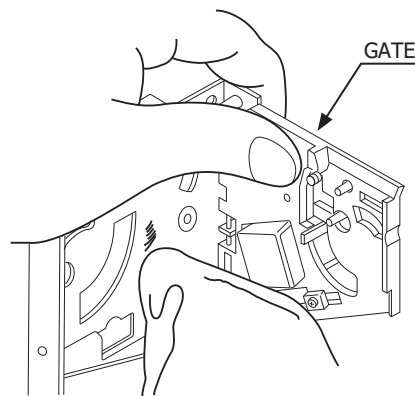

FIG. 12a

- 4 Remove and clean smears by using a soft cloth dipped in water or diluted chemical detergent and then squeezed dry.
- 5 Remove the CRADLE.
When removing the retaining ring (E ring), be very careful so as not to bend the rotary shaft.

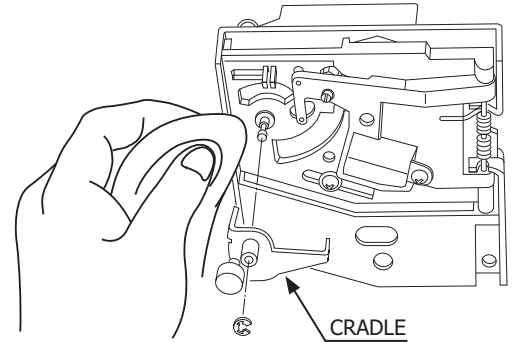

FIG. 12b

- 6 Remove stain from the rotary shaft and shaft receiving portions by wiping off with a soft cloth, etc.
- 7 After wiping off as per previous step, further apply a dry cloth, etc. to cause the Coin Selector to dry completely.

Coin Insertion Test

Once every month, when performing the Coin SW Test, simultaneously check the following:

- Does the Coin Meter count satisfactorily?
- Does the coin drop into the cashbox correctly?
- Is the coin rejected when inserted while keeping the REJECT Button pressed down?

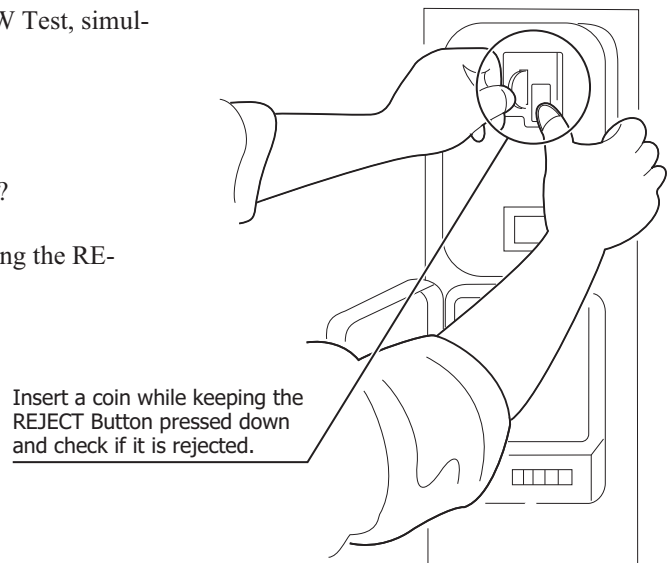

FIG. 12c

CREDIT SETTINGS

Credit Board Mode Settings Switch 3																			
Country	Setting	Switch 3 Setting					Coin Validator Programming					C120/SR3 Only							
		SW1	SW2	SW3	SW4	SW5	SW6	COIN1	COIN2	COIN3	COIN4	COIN5	COIN6	COIN7	COIN8	COIN9	COIN10	COIN11	COIN12
UK	Coin Controls C220 Parallel	OFF	OFF	OFF	OFF		£1	50p new	20p	10p	-	50p old	-	-	-	-	-	-	-
UK	Coin Controls C220 Binary	ON	OFF	OFF	OFF		£1	50p new	20p	10p	-	50p old	-	£2	-	-	-	-	-
UK	Coin Controls C220 Binary	OFF	ON	OFF	OFF		£1	50p new	20p	10p	-	£2	-	50p old	-	-	-	-	-
UK	Coin Controls SR3 Parallel	ON	ON	OFF	OFF		£1	50p new	20p	10p	-	£2	-	50p old	-	-	-	-	-
UK	Coin Controls SR3 Parallel	OFF	OFF	ON	OFF		£2 €2	50p new 50¢	20p 20¢	20p 20¢	10p 10¢	-	-	-	50p old	-	-	-	-
UK	Mars ME/MS 111 Parallel	ON	OFF	ON	OFF		£1	£2	20p	10p	50p new	50p old	-	-	-	-	-	-	-
UK	NRI Parallel	OFF	ON	ON	OFF		10p	20p	50p	£1	£2	-	-	-	-	-	-	-	-
Belgium	Parallel	ON	ON	ON	OFF		-	50Bfr	20Bfr	5Bfr	-	-	-	-	-	-	-	-	-
Holland	Parallel	OFF	OFF	OFF	ON		-	5NLG	2.5NLG	1NLG	-	-	-	-	-	-	-	-	-
Austria	SR3 Parallel	ON	OFF	OFF	ON		20Sch	10Sch	5Sch	1Sch	-	-	-	-	-	-	-	-	-
Spain	Coin Controls C220 Binary	OFF	ON	OFF	ON		500Pta	200Pta	100Pta	50Pta	25Pta	200Pt old	50Pta old	25Pta old	-	-	-	-	-
Spain	SR3/NRI Parallel	ON	ON	OFF	ON		500Pta	200Pta	100Pta	50Pta	25Pta	25Pta	-	200Pta	-	50Pta old	25Pta old	-	-
Spain	Coin Controls C220 Parallel	OFF	OFF	ON	ON		100Pta	50Pta new	-	25Pta new	-	50Pta old	-	25Pta old	-	-	-	-	-
Portugal Euro	Parallel	ON	OFF	ON	ON		200Es €1	100Es 50¢	50Es	-	-	-	-	-	-	-	-	-	-
	TBA				OFF		TBA												
	Channels				ON		TBA												
					OFF		Direct Mode												
					ON		2 channel Mode												

Please Note
The credit board automatically sets the validator for parallel and binary operation through an output on pin 8 of the 17 way pinstrip. For the feature to work it is necessary for the validator interconnecting cable to include at wire at this position

Note: These switch settings are under constant review and may change due to world currency updates.

- Set SW 1 according to the option settings found in the relevant Price of Play Settings Table on the following pages.
- For Germany (DM), France (Fr) & Switzerland (SFr), use the appropriate existing setting shown above (from another country) that matches the coin ratios programmed into your coin mech.
- Set SW 3 on the VTS /Excel board as shown in the table above corresponding to the country required.

PRICE OF PLAY SETTINGS FOR UK

	Price	Bonus					DIL Switch 1				
							1	2	3	4	5
1	10p	50p = 5 plays	£1 = 10 plays	£2 = 20 plays		OFF	OFF	OFF	OFF	OFF	
2	10p	50p = 6 plays @ 8.33p per play	£1 = 12 plays @ 8.33p per play	£2 = 24 plays @ 8.33p per play		ON	OFF	OFF	OFF	OFF	
3	20p	50p = 2.5 plays	£1 = 5 plays	£2 = 10 plays		OFF	ON	OFF	OFF	OFF	
4	20p	50p = 3 plays @ 16.66p per play	£1 = 6 plays @ 16.66p per play	£2 = 12 plays @ 16.66p per play		ON	ON	OFF	OFF	OFF	
5	30p	50p = 1.66 plays	£1 = 3.33 plays	£2 = 6.66 plays		OFF	OFF	ON	OFF	OFF	
6	30p	50p = 1.66 plays	£1 = 4 plays @ 25p per play	£2 = 8 plays @ 25p per play		ON	OFF	ON	OFF	OFF	
7	30p	50p = 2 plays @ 25p per play	£1 = 4 plays @ 25p per play	£2 = 8 plays @ 25p per play		OFF	ON	ON	OFF	OFF	
8	30p	50p = 2 plays @ 25p per play	£1 = 3 plays @ 33.33p per play	£2 = 6 plays @ 33.33p per play		ON	ON	ON	OFF	OFF	
9	40p	50p = 1.25 plays	£1 = 2.5 plays	£2 = 5 plays		OFF	OFF	OFF	ON	OFF	
10	40p	50p = 1.25 plays	£1 = 3 plays @ 33.3p per play	£2 = 6 plays @ 33.3p per play		ON	OFF	OFF	ON	OFF	
11	50p	50p = 1 play	£1 = 2 plays	£2 = 4 plays		OFF	ON	OFF	ON	OFF	
12	50p	50p = 1 play	£1 = 3 plays @ 33.3p per play	£2 = 6 plays @ 33.3p per play		ON	ON	OFF	ON	OFF	
13	50p	50p = 1 play	£1 = 2 plays	£2 = 5 plays @ 40p per play		OFF	OFF	ON	ON	OFF	
14	60p	50p = 0.83 play	£1 = 1.66 plays	£2 = 3.33 plays		ON	OFF	ON	ON	OFF	
15	60p	50p = 0.83 play	£1 = 2 plays @ 50p per play	£2 = 4 plays @ 50p per play		OFF	ON	ON	ON	OFF	
16	80p	50p = 0.62 play	£1 = 1.25 plays	£2 = 2.5 plays		ON	ON	ON	ON	OFF	
17	80p	£1 = 1.25 plays	£1.50 = 2 plays @ 75p per play	£2 = 2.5 plays		OFF	OFF	OFF	OFF	ON	
18	£1	2x50p = 1 play	£1 = 1 play	£2 = 2 plays		ON	OFF	OFF	OFF	ON	
19	£1	2x50p = 1 play	£1 = 1 play	£2 = 3 plays @ 66.6p per play		OFF	ON	OFF	OFF	ON	
20	£1	2x50p = 1 play	£2 = 2 plays	£4 = 5 plays @ 80p per play		ON	ON	OFF	OFF	ON	
21	£1.50	3x50p = 1 play	£1 = 0.66 plays	£3 = 2 plays		OFF	OFF	ON	OFF	ON	
22	£1.50	3x 50p = 1 play	£1 = 0.66 plays	£2 = 2 plays @ £1 per play		ON	OFF	ON	OFF	ON	
23	£2	4x 50p = 1 play	£1 = 0.5 play	£2 = 1 play		OFF	ON	ON	OFF	ON	
24	£2	4x 50p = 1 play	£1 = 0.5 play	£5 = 3 plays @ £1.66 per play		ON	ON	ON	OFF	ON	
25	£3	6x50p = 1 play	£1.50 = 0.5 play	£3 = 1 play		OFF	OFF	OFF	ON	ON	
26	£3	6x50p = 1 play	£1.50 = 0.5 play	£5 = 2 plays @ £2.50 per play		ON	OFF	OFF	ON	ON	
27	£5	£1 = 0.2 play	£5 = 1 play	£10 = 2 plays		OFF	ON	OFF	ON	ON	
28	£5	£1 = 0.2 play	£5 = 1 play	£10 = 3 plays @ £3.33p per play		ON	ON	OFF	ON	ON	
29	£7.50	£5 = 0.66 play	£10 = 1.33 plays	£15 = 2 plays		OFF	OFF	ON	ON	ON	
30	£7.50	£5 = 0.66 play	£10 = 1.33 plays	£10 = 2 plays @ £5 per play		ON	OFF	ON	ON	ON	
31	£10	£10 = 1 play	£20 = 2 play	£30 = 3 play		OFF	ON	ON	ON	ON	
32			Free Play			ON	ON	ON	ON	ON	

PRICE OF PLAY SETTINGS FOR EURO

	Price	Bonus		DIL Switch 1				
				1	2	3	4	5
1	10¢	50¢ = 5 plays	€1 = 10 plays	€2 = 20 plays	OFF	OFF	OFF	OFF
2	10¢	50¢ = 6 plays @ 8.33p per play	€1 = 12 plays @ 8.33¢ per play	€2 = 24 plays @ 8.33¢ per play	ON	OFF	OFF	OFF
3	20¢	50¢ = 2.5 plays	€1 = 5 plays	€2 = 10 plays	OFF	ON	OFF	OFF
4	20¢	50¢ = 3 plays @ 16.66¢ per play	€1 = 6 plays @ 16.66¢ per play	€2 = 12 plays @ 16.66¢ per play	ON	ON	OFF	OFF
5	30¢	50¢ = 1.66 plays	€1 = 3.33 plays	€2 = 6.66 plays	OFF	OFF	ON	OFF
6	30¢	50¢ = 1.66 plays	€1 = 4 plays @ 25¢ per play	€2 = 8 plays @ 25¢ per play	ON	OFF	ON	OFF
7	30¢	50¢ = 2 plays @ 25¢ per play	€1 = 4 plays @ 25¢ per play	€2 = 8 plays @ 25¢ per play	OFF	ON	ON	OFF
8	30¢	50¢ = 2 plays @ 25¢ per play	€1 = 3 plays @ 33.33¢ per play	€2 = 6 plays @ 33.33¢ per play	ON	ON	ON	OFF
9	40¢	50¢ = 1.25 plays	€1 = 2.5 plays	€2 = 5 plays	OFF	OFF	OFF	ON
10	40¢	50¢ = 1.25 plays	€1 = 3 plays @ 33.33¢ per play	€2 = 6 plays @ 33.33¢ per play	ON	OFF	OFF	ON
11	50¢	50¢ = 1 play	€1 = 2 plays	€2 = 4 plays	OFF	ON	OFF	ON
12	50¢	50¢ = 1 play	€1 = 3 plays @ 33.33¢ per play	€2 = 6 plays @ 33.33¢ per play	ON	ON	OFF	ON
13	50¢	50¢ = 1 play	€1 = 2 plays	€2 = 5 plays @ 40¢ per play	OFF	OFF	ON	ON
14	60¢	50¢ = 0.83 play	€1 = 1.66 plays	€2 = 3.33 plays	ON	OFF	ON	ON
15	60¢	50¢ = 0.83 play	€1 = 2 plays @ 50¢ per play	€2 = 4 plays @ 50¢ per play	OFF	ON	ON	ON
16	80¢	50¢ = 0.62 play	€1 = 1.25 plays	€2 = 2.5 plays	ON	ON	ON	ON
17	80¢	€1 = 1.25 plays	€1.50 = 2 plays @ 75¢ per play	€2 = 2.5 plays	OFF	OFF	OFF	ON
18	€1	2x50¢ = 1 play	€1 = 1 play	€2 = 2 plays	ON	OFF	OFF	ON
19	€1	2x50¢ = 1 play	€1 = 1 play	€2 = 3 plays @ 66.6¢ per play	OFF	ON	OFF	ON
20	€1	2x50¢ = 1 play	€2 = 2 plays	€4 = 5 plays @ 80¢ per play	ON	ON	OFF	ON
21	€1.50	3x50¢ = 1 play	€1 = 0.66 plays	€3 = 2 plays	OFF	OFF	ON	ON
22	€1.50	3x 50¢ = 1 play	€1 = 0.66 plays	€2 = 2 plays @ €1 per play	ON	OFF	ON	ON
23	€2	4x 50¢ = 1 play	€1 = 0.5 play	€2 = 1 play	OFF	ON	ON	ON
24	€2	4x 50¢ = 1 play	€1 = 0.5 play	€5 = 3 plays @ €1.66 per play	ON	ON	ON	ON
25	€3	6x50¢ = 1 play	€1.50 = 0.5 play	€3 = 1 play	OFF	OFF	OFF	ON
26	€3	6x50¢ = 1 play	€1.50 = 0.5 play	€5 = 2 plays @ €2.50 per play	ON	OFF	OFF	ON
27	€5	€1 = 0.2 play	€5 = 1 play	€10 = 2 plays	OFF	ON	OFF	ON
28	€5	€1 = 0.2 play	€5 = 1 play	€10 = 3 plays @ 3.33¢ per play	ON	ON	OFF	ON
29	€7.50	€5 = 0.66 play	€10 = 1.33 plays	€15 = 2 plays	OFF	OFF	ON	ON
30	€7.50	€5 = 0.66 play	€10 = 1.33 plays	€10 = 2 plays @ €5 per play	ON	OFF	ON	ON
31	€10	€10 = 1 play	€20 = 2 play	€30 = 3 play	OFF	ON	ON	ON
32		Free Play			ON	ON	ON	ON

13 REPLACING THE FLUORESCENT LAMPS

WARNING

- When working with the product, be sure to turn the power off. Working with the power on may cause an electric shock or short circuit.
- You may get burned by a hot fluorescent lamp or other lamps. Pay full attention to the lamps when performing the work.
- There is the danger of short circuits or smoke generation due to deterioration of insulation in lighting fixtures resulting from age deterioration. Check for anomalies such as the following: Does it smell like something is burning? Is there socket discoloration? Are any lamps being replaced frequently? Do lamps not go on properly?

CAUTION

- Be careful when handling the plastic parts. Failure to observe this may cause injury or damage due to fragments, etc.
- To perform the operation safely and accurately you must use a safe, steady footstool or step. Working without this may lead to a fall and possible injury.
- When performing the fluorescent lamp exchange, do not hold onto the billboard carrier (the round pipe section). Holding or hanging off this may bend it out of shape or damage it, and could lead to a fall or an accident.

Replacing the Billboard Box Florescent Lamp

1 Turn off the power.

2 Use a stool or steps when working on the top of the cabinet. Remove the two screws from the top of the billboard box.

SCREW (2)
M4x12, w/flat & spring washers

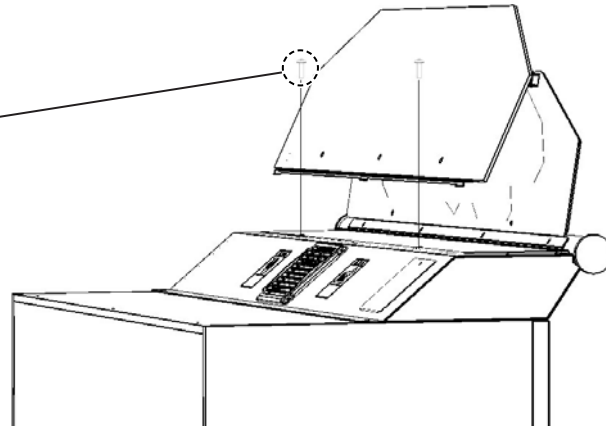

FIG. 13a

3 Remove the FL cover plate to reveal FL lamp..

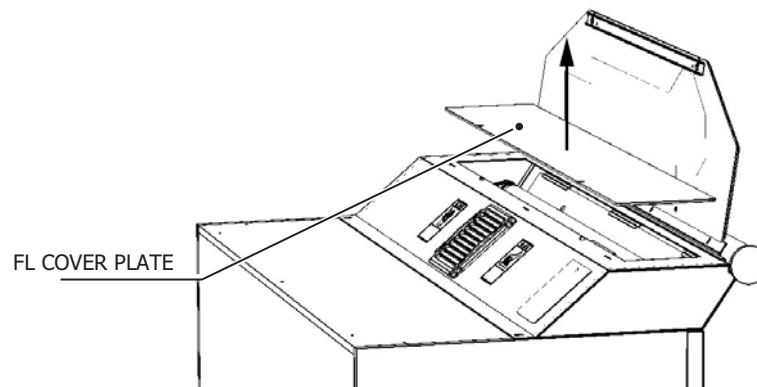
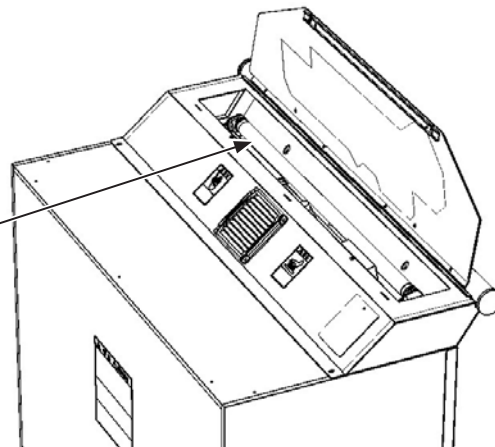

FIG. 13b

4 Change the florescent lamp.

FLORESCENT LAMP 30W
LT1014



5 Re-build the billboard by following steps 1 to 4 in reverse order..

14 PERIODIC INSPECTION

WARNING

- Once a year, check to see if power cords are damaged, the plug is securely inserted, dust is accumulated between the socket outlet and the power plug, etc. Using the product with accumulated dust in the interior may cause fire or electric shock.
- Do not attempt to clean this product using high pressure equipment such as a hose or jet wash. Do not submerge the machine in any body of water such as the atlantic or pacific oceans. Salt water can erode certain parts of the product which can cause failure in operation.
- Once a year, request the office shown on this manual or the dealer from whom the product was originally purchased to perform the internal cleaning. Using the product with accumulated dust in the interior may cause fire or other accidents. Note that you are liable for the cost of cleaning the interior parts.
- There is the danger of accidents involving electrical short circuits or fire caused by factors such as the deterioration of insulation in electrical and electronic equipment over time. Check that there are no abnormalities such as odors from

STOP IMPORTANT

The interior of the cabinet is hard to see from the outside which may lead to willful misconduct by players or accidents going unnoticed. When the game is not in use, check the interior at regular intervals and make sure that nothing has been forgotten or placed on the seats.

In order to maintain the performance of this product and operate it safely, inspect the following items routinely and perform maintenance.

The player directly touches and manipulates the Control Unit with his/her hands. Clean it as necessary and provide hand towels, etc., so that players will be comfortable while playing.

The service manual referred in the table is the LINDBERGH service manual, which is provided separately.

TABLE 14 PERIODIC INSPECTION TABLE

ITEMS	DESCRIPTION	PERIOD	REFERENCE
CABINET	Confirm that adjusters contact floor	Daily	Chapter 3
	Seat check, removal of forgotten / other items	Daily	Chapter 3
PROJECTOR	Screen cleaning	Weekly	Chapter 10
	Check screen adjustment	1 month	Chapter 10
CONTROL UNIT	Cleaning	As appropriate	Chapter 3
	Inspection of volume	1 month	
COIN SELECTOR	Inspection of coin switch	1 month	
	Coin insertion test	1 month	Chapter 12
	Coin Selector cleaning	3 months	Chapter 12
GAME BOARD	Individual tests	1 month	Service manual, Chapter 4
	Check of settings	1 month	
FLUORESCENT LAMP & LAMPS	Inspection of lighting fixtures	As appropriate	Chapter 13
ELECTRICAL/ELECTRONIC PARTS	Inspection	As appropriate	See above.
POWER CABLE	Inspection, Cleaning	1 year	See above.
CABINET INTERIOR	Cleaning	1 year	See above.
CABINET SURFACES	Cleaning	As appropriate	See below.

Cleaning the Cabinet Surfaces

When the cabinet surfaces become dirty, remove stains with a soft cloth soaked in water or diluted (with water) chemical detergent and then wrung dry. To avoid damaging the finish, do not use such solvents as thinner, benzene, etc. (other than ethyl alcohol) or abrasives (bleaching agent and chemical dust-cloth).

Some general-purpose household, kitchen, and furniture cleaning products may contain strong solvents that degrade plastic parts, coatings, and print. Before using any cleaning product, read the product's cautionary notes carefully and test the product first on a small area that is not highly visible.

15 TROUBLESHOOTING

WARNING

- If an error message is displayed, have the problem looked at by a store maintenance person or a technician. Unless the problem is addressed by someone with specialized knowledge or skills, there could be electrical shock, short circuits or fire. If there are no store maintenance people or technicians, cut off the power immediately and contact the office shown in this manual or the dealer from whom the product was originally purchased.
- If problems other than those covered in this manual arise, or if no improvements can be noted after measures given in this manual have been taken, do not take measures indiscriminately. Cut off the power immediately and contact the office shown in this manual or the dealer from whom the product was originally purchased. Indiscriminate countermeasures could lead to unforeseeable accidents. They could also result in permanent damages.
- When working with the product, be sure to turn the power off. Working with the power on may cause an electric shock or short circuit.
- Be careful not to damage the wires. Damaged wires may cause an electric shock, short circuit or present a risk of fire.
- After the cause of circuit protector activation has been removed, have the circuit protector re-engaged. If the unit is used continuously as is, there could be heat generation or fire, depending on the cause of the activation.

CAUTION

- When removing and replacing parts, take due care not to trap or pinch your fingers.
- The Control Units contain gears, cams and other moving machine parts. Take due care not to trap or pinch your fingers.

An error message indicates an error with the game board. Check the separate LINDBERGH Service Manual for more details.

If a problem has occurred, first inspect the connection of the wiring connector.

TABLE 15 TROUBLESHOOTING TABLE

PROBLEMS	CAUSE	COUNTERMEASURES
When the main SW is turned ON, the machine is not activated.	The power is not ON.	Firmly insert the plug into the outlet.
	Incorrect power source/voltage.	Make sure that the power supply/voltage are correct.
	The Circuit Protector of the supply functioned due to momentary overcurrent.	After eliminating the cause of overload, have the Circuit Protector of the supply restored.
	The screen is not adjusted correctly.	Adjust the screen correctly. (See chapter 10.)
The projector does not project an image.	The VGA cable may not be fitted correctly. .	Check VGA connection at Lindbergh and at PTV, ensure that the 2 thumbscrews are secure at each end.
No sound output.	Volume is not adjusted properly.	Adjust the volume. (See chapter 9.)
	Board or amp malfunction.	Check by performing a speaker test. (See 9.)
The Control Unit (Gun) does not target correctly.	Due to external or environmental factors the targeting is off.	Perform calibration in TEST Mode. (See 9.)
	Sensor may be faulty	Replace the Optic Sensor
The Control Unit is not operating properly.	Microswitches damaged.	Check ON, OFF on the input test and if it is not working exchange the microswitch. (See 11-4.) Microswitch:
Control Unit does not respond.	Check calibration	Alter the TEST Mode settings.
	Check solenoid	Remove faulty solenoid and replace.
	Sensor damaged.	Exchange the sensor.
The Control Unit makes a lot of noise when it vibrates.	Due to a problem with the vibration parts or wear over time, the internal parts have moved.	Adjust the position of the vibration parts. (See 11-6.)
The fluorescent lights don't come on.	The fluorescent light is dead.	Exchange the fluorescent light. (See chapter 13.)
The lights in the cabinet don't come on.	The fluorescent bulbs are dead.	Exchange the fluorescent bulbs. (See chapter 13.)

16 GAME BOARD

WARNING

- When working with the product, be sure to turn the power off. Working with the power on may cause an electric shock or short circuit.
- Be careful not to damage the wires. Damaged wires may cause electric shock or short circuit or present a fire risk.
- Do not expose the game board, etc. without a good reason. Failure to observe this can cause electric shock hazard or malfunctioning.
- Do not use this product with connectors other than those that were connected and used with the game board at the time of shipping. Do not carelessly connect wires to connectors that were not used at the time of shipping, as this may cause overheating, smoke or fire damage.
- When returning the game board after making repairs or replacements, make sure that there are no errors in the connection of connectors. Erroneous connections can lead to electrical shock, short circuits or fires.
- When connecting a connector, check the direction carefully. Connectors must be connected in only one direction. If indiscriminate loads are applied in making connections, the connector or its terminal fixtures could be damaged, resulting in electrical shock, short circuits or fires.

CAUTION

- In this product, setting changes are made during the test mode. The game board need not be operated. Use the game board, etc. as is with the same setting made at the time of shipment so as not to cause electric shock and malfunctioning.
- Static electricity from your body may damage some electronics devices on the IC board. Before handling the IC board, touch a grounded metallic surface so that the static electricity can be discharged.

STOP IMPORTANT

- When a game board is to be replaced, put the old game board with anomaly into a special box for replacing the game board and send it. If a special box is not available or if it has been damaged, arrange to obtain a box with the following part number/name.
[601-11691/CARTON BOX LBG]
- For replacement or repair, pack the game board and send it without disassembling it. Order for servicing might not be accepted if any part of the game board has been removed. If any part is removed, a service fee will be charged even if the warranty period has not yet expired.
- Do not remove the key chip from the game board before sending the board for servicing.

16-1 HOW TO REMOVE GAME BOARD

The game board (LINDBERGH) is inside the front door PCB to the right side when facing the projector screen. Remove the LINDBERGH together with the wooden base (PCB Board) on which it has been mounted.

1 Turn off the power.

2 Remove the anti-release screw.

TRUSS SCREW (2), black
M4x40



FIG. 16-1a

3 Remove the door slowly being careful not to disconnect the fan harness..



FIG. 16-1b

4 Disconnect all of the connectors connected to the LINDBERGH.



FIG. 16-1c

5 Remove the 4 screws which secure the Lindbergh to the wooden base..

SCREW (4)
M4x16, w/flat & spring washers, large flat washer used

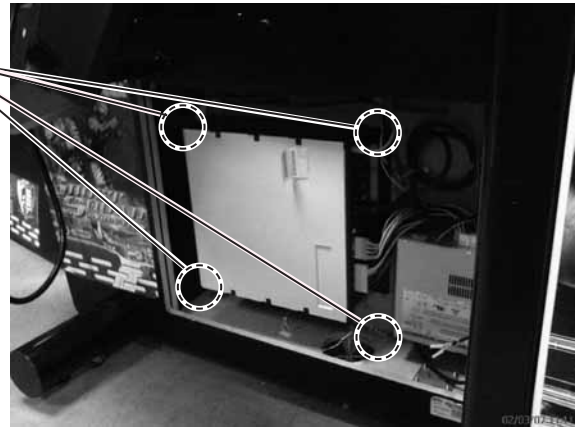

FIG. 16-1d

6 Replace the Lindbergh by following this operation in reverse.

16-2 COMPOSITION OF THE GAME BOARD

STOP IMPORTANT

- With the key chip inserted into it, this board serves as a special-purpose game board for the product.
- Use with the dip switches (DIP SW) on the board at the prescribed settings. If settings do not match the product, an error message will be displayed. In some cases, the game cannot be started.

ASSY CASE LBG L 1GB LGJ EXP (844-0012D-02)

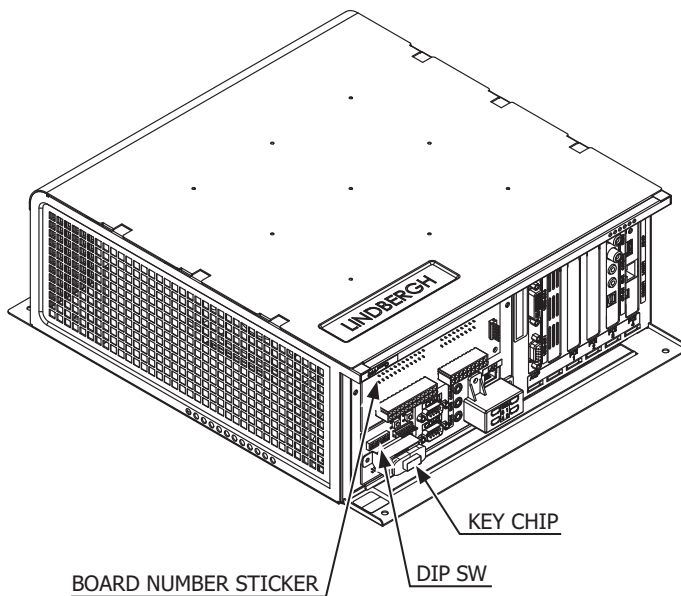

FIG. 16-2a

DIP SW SETTING

Use this product with the DIP SW settings shown in the figure below.



FIG. 16-2b

17 DESIGN RELATED PARTS

For the warning display stickers, refer to Section 1.

17 DESIGN RELATED PARTS



18 PARTS LIST

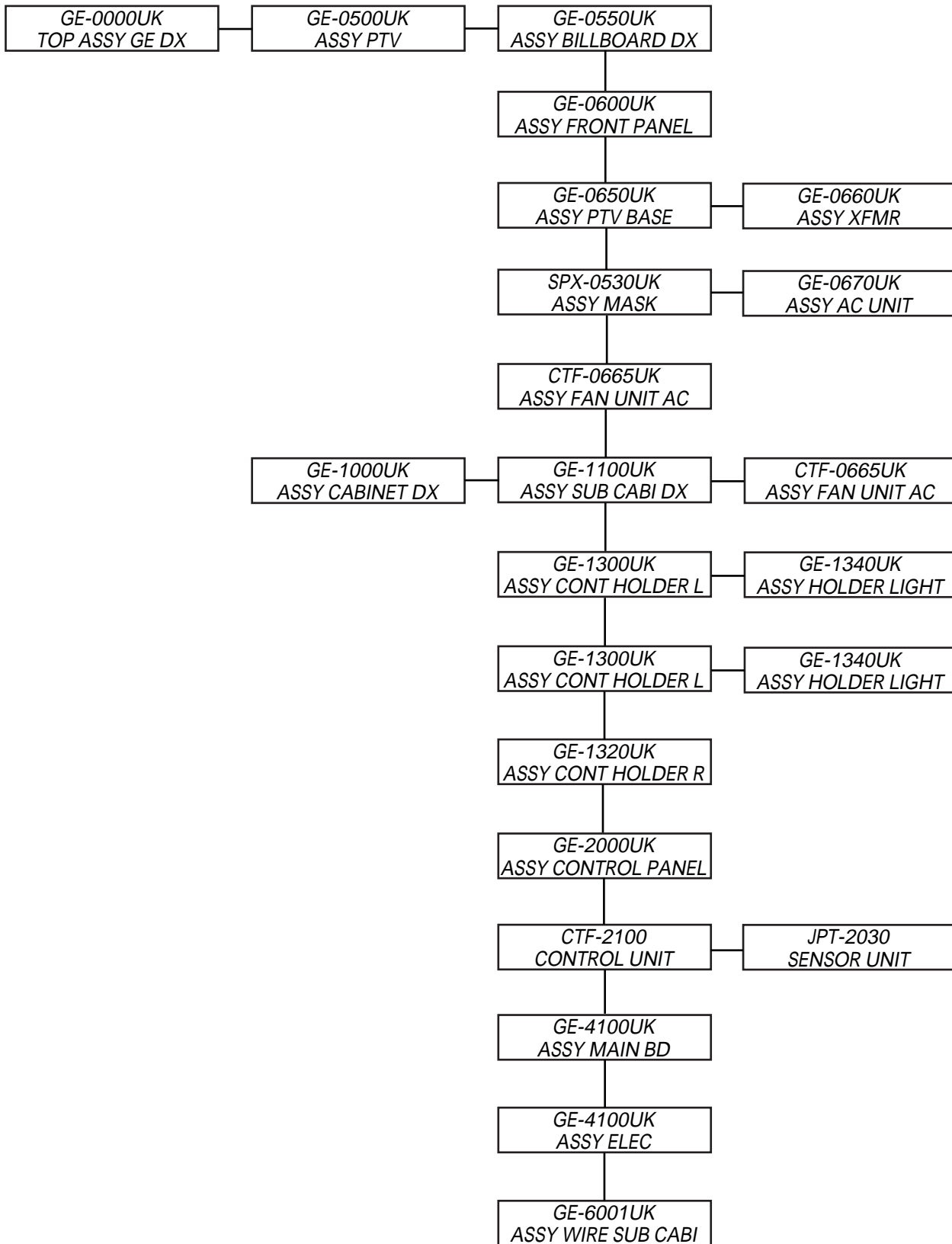

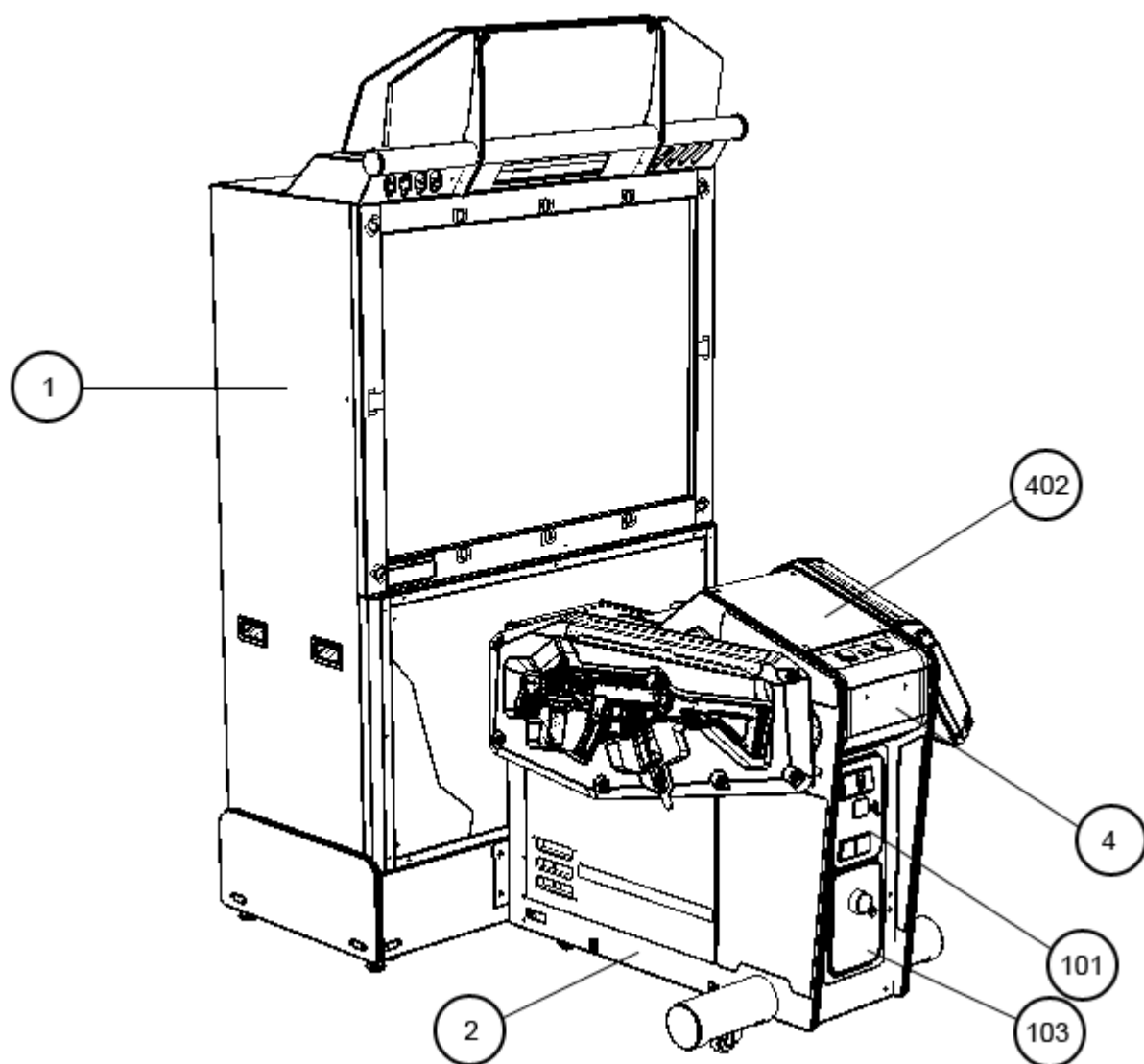

① TOP ASSY GE DX (GE-0000UK)

(D-2/2)

ITEM NO.	PART NO.	DESCRIPTION	NOTE
1	GE0500UK	ASSY PTV	
2	GE1000UK	ASSY CABINET DX	
3	CTF-0001UK	JOINT BRKT UPPER	
4	JEY-0005	DENOMI PLATE	
8	LB1046	LABEL TESTED FOR ELEC SPEC	
10	LB1130	LABEL WEEE WHEELIE BIN	
20	PK0360	PALLET PTV CTF	
21	PK0412	COVER SHRINK PTV	(NOT SHOWN)
22	PK0362	PALLET GUN CTF	
23	PK0413	COVER SHRINK GE GUN CABI	(NOT SHOWN)
24	PK0364	BOX BILLBOARD	
101	220-5374-01	DOOR DFMD W/FR&LOCK C120 UNIV	
102	220-5574UK	LOCK (J9117) KEY TO LIKE 22MM	
103	220-5725-05B	DOOR SINGLE MINI H.SECURITY BLK	
104	220-5574-110UK	LOCK KEY DIFFERS 11MM W/O CAM	
201	030-000840-SB	M8X40 BLT W/S BLK	
202	068-852216-0B	M8 WSHR 22OD FLT BLK	
203	000-T00520-0B	M5X20 MSCR TH BLK	
204	068-552016-0B	M5 WSHR 20OD FLT BLK	
401	420-6831-11UK	OWNERS MANUAL GE DX	
402	GE-1001UK	STICKER INSTRUCTION MULTI GE	
403		MANUAL LINDBERGH SERVICE	
413	540-0006-01	WRENCH M4 TMP SCR	
414	540-0007-01	WRENCH M5 TMP SCR	
416	LM1227	UK MAINS LEAD 10A WITH PLUG	
417	LM1246	EUROLEAD 10A EUROPEAN SOCKET	
418	SAECE-XXX	DECLARATION OF CONFORMITY	(NOT SHOWN)

SORRY BUT NO IMAGE AT TIME OF PRINT

② ASSY PTV (GE-0500UK)

(D-2/2)

ITEM NO.	PART NO.	DESCRIPTION	NOTE
2	GE-0550UK	ASSY BILLBOARD BOX	
3	GE-0600UK	ASSY FRONT PANEL	
4	GE-0650UK	ASSY PTV BASE	
5	SPX-0530UK	ASSY MASK	
8	DYN-0501	PANEL MOUNT BRKT L	
9	DYN-0502	PANEL MOUNT BRKT R	
10	CTF-0665UK	FAN UNIT AC UK	
11	GE-0511UK	STICKER PTV SIDE L	
12	GE-0512UK	STICKER PTV SIDE R	
13	SPX-0532UK	PROTECT SCREEN PTV	
14	SPX-0533UK	RETAINING BRKT HORIZ PTV	
101	200-5788-31	PROJECTION DSPL T 50TYPE 31K	
201	000-T00520-0B	M5X20 MSCR TH BLK	
202	068-552016-0B	M5 WSHR 20OD FLT BLK	
203	000-F00412	M4X12 WSCR CSK PAS	
204	000-P00516-WB	M5X16 MSCR PAN W/FS PAS	
205	000-T00525-0B	M5X25 MSCR TH BLK	

③ ASSY CABINET DX (GE-1000UK)

(D-1/2)

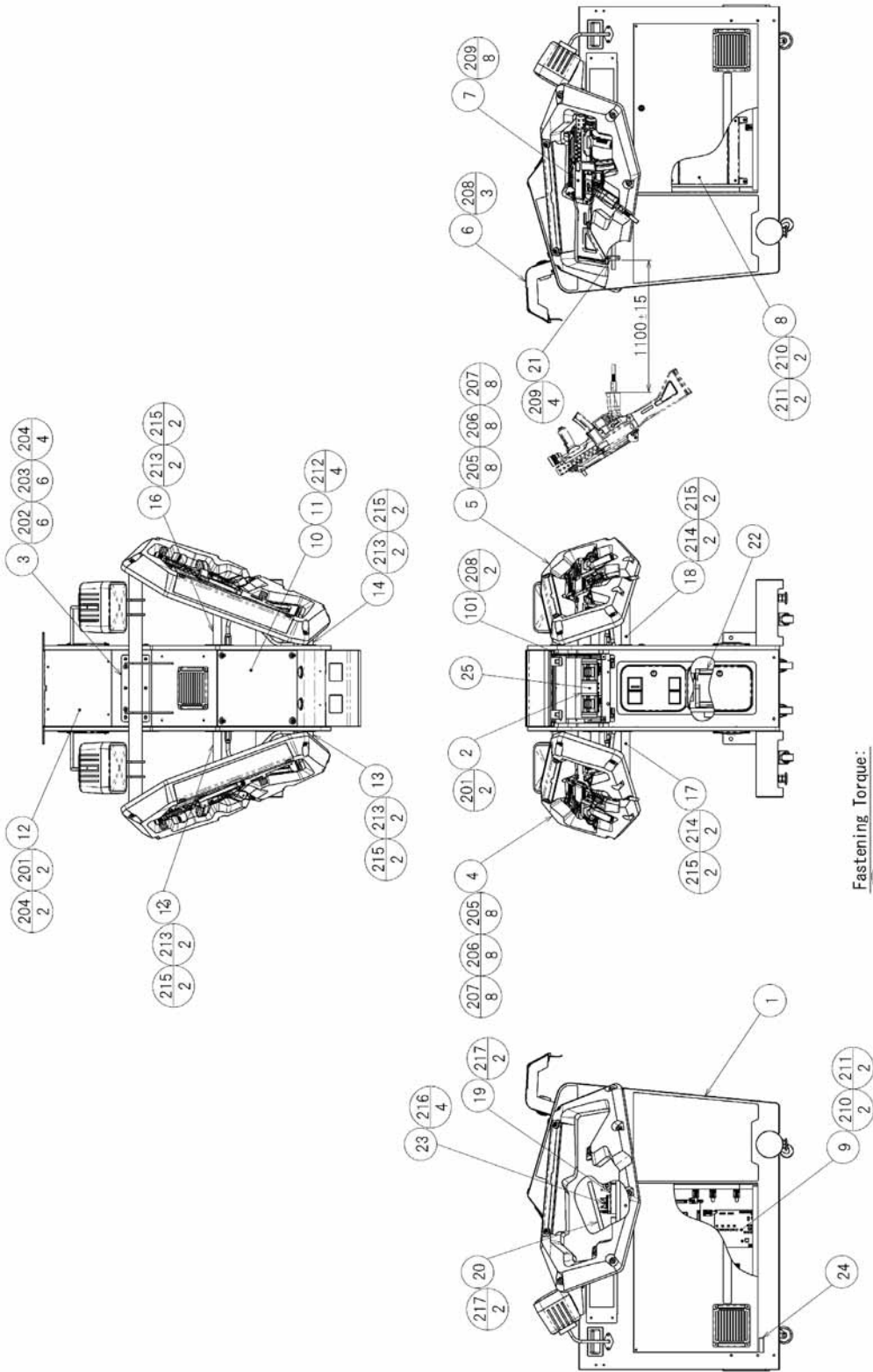

③ ASSY CABINET DX (GE-1000UK)

(D-2/2)

ITEM NO.	PART NO.	DESCRIPTION	NOTE
1	GE-11000UK	ASSY SUB CABI DX	
3	CTF-1201-01UK	JOINT PIPE REAR	
4	GE-1300UK	ASSY CONTROLLER HOLDER L	
5	GE-1320UK	ASSY CONTROLLER HOLDER R	
6	GE-2000UK	ASSY CONTROL PANEL BASE	
7	CTF-2100	CONTROL UNIT	
8	GE-4000UK	ASSY MAIN BD	
9	GE-4100UK	ASSY ELEC	
10	CTF-1001-AUK	INSTR PLATE BLANK	
11	CTF-1002UK	WASHER CTF	
12	CTF-1003UK	LAMP LID	
13	CTF-1004UK	JOINT PIPE FRONT L	
14	CTF-1005UK	JOINT PIPE FRONT R	
15	CTF-1006UK	JOINT PIPE UPPER L	
16	CTF-1007UK	JOINT PIPE UPPER R	
17	CTF-1008UK	JOINT PIPE LOWER L	
18	CTF-1009UK	JOINT PIPE LOWER R	
19	CTF-1010UK	FUSE BD BRKT	
20	CTF-1011UK	FUSE BD COVER	
21	JPT-3101	TUBE CLAMP	
22	253-5366	CASJ BOX	
23	839-1243	FUSE BD CTF	
24	GE-1001-BUK	PLATE INSTR SUPPORT	
201	000-T00408-0B	M4X8 MSCR TH BLK	
202	030-000820-0B	M8X20 BLT HEX BLK W/S	
203	060-F00800-0B	M8 WSHR FORM A FLT BLK	
204	000-T00420-0B	M4X20 MSCR TH BLK	
205	050-C00600-3B	M6 NUT DOME TYPE 3 BLK	
206	060-S00600-0B	M6 WSHR SPR BLK	
207	060-F00600-0B	M6 WSHR FORM A FLT BLK	
208	050-F00400	M4 NUT FLG SER PAS	
209	000-T00420-0C	M4X20 MSCR TH CRM	
210	032-000430	M4X30 W/BLT PAS	
211	068-441616	M4 WSHR 16OD FLT PAS	
212	FAS-290038	HEX SKT LH CAP SCR STN M5X10	
213	030-000630-SB	M6X30 BLT W/S BLK	
214	030-000645-SB	M6X45 BLT W/S BLK	
216	000-P00320-W	M3X20 MSCR PAN W/FS PAS	
217	000-P00420-W	M4X20 MSCR PAN W/FS PAS	
218	000-P00408	M4X8 MSCR PAN PAS	
219	050-H00400	M4 NUT PAS	
220	060-S00400	M4 WSHR SPR PAS	
221	060-F00400	M4 WSHR FORM A FLT PAS	

④ ASSY BILLBOARD (GE-0550UK)

(D1-2)

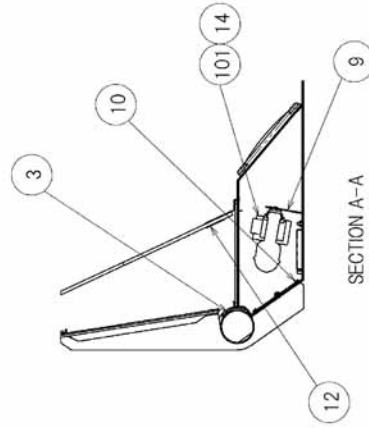
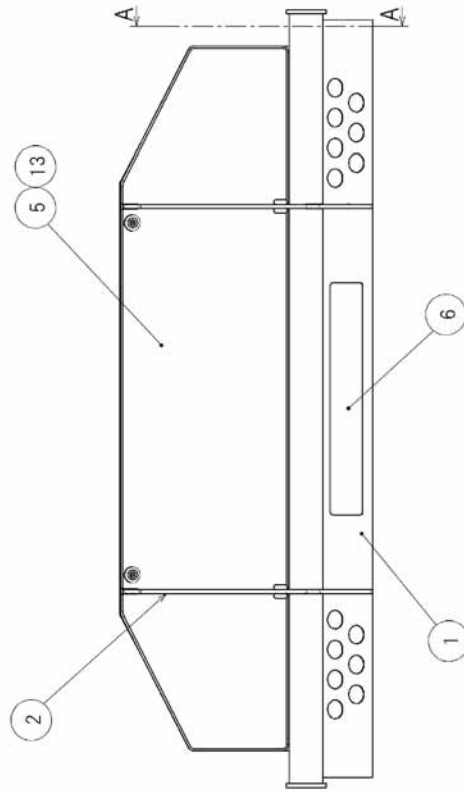
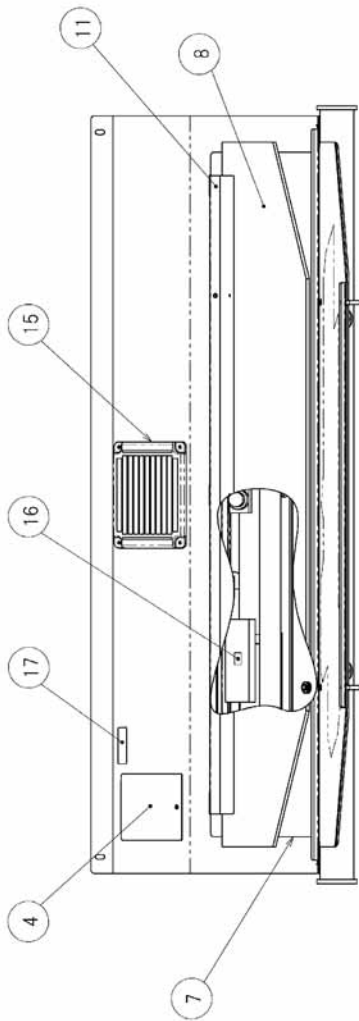

④ ASSY BILLBOARD (GE-0550UK)

(D2-2)

ITEM NO.	PART NO.	DESCRIPTION	NOTE
1	GE-0551UK	BILLBOARD BOX	
2	CTF-0552UK	BILLBOARD STAY	
3	CTF-0553UK	BILLBOARD STAY HOLDER	
4	CTF-0554UK	CONNECTOR LID	
5	GE-0555UK	BILLBOARD PLATE	
6	GE-0556UK	BILLBOARD FRONT PLATE	
7	CTF-0557UK	BILLBOARD LID	
8	GE-0558UK	BILLBOARD POP	
9	CTF-0559UK	BILLBOARD FL BRKT	
10	GE-0560UK	FRONT PLATE SASH	
11	CTF-0561UK	POP BRKT	
12	CTF-0562UK	POP HOLDER	
13	CTF-1002UK	WASHER CTF	
15	253-5460-01	AIR VENT BLACK	
16	LB1119	STICKER 100V 30W	
17	LB1104	STICKER CAUTION HOT SURFACE	
18	LB1102	STICKER DANGEROUS VOLTAGE	
19	GE-0653UK	BOX LED	
101	390-5695-30-AUK	FL TRAY 100V 30W	
102	LT1014	TUBE FL 30W 36" 25MM DIA	
103	838-0002UK	LED FLASHER DRIVER BD	(NOT SHOWN)
104	OS1230	FOAM STRIP 2MM X 10MM	
201	000-P00410-WB	M4X8 MSCR PAN W/FS PAS	
202	068-441616-0B	M4 WSHR 16OD FLT BLK	
203	000-F00408	M4X8 MSCR CSK PAS	
204	000-T00408-0B	M4X8 MSCR TH BLK	
205	FAS-290034	HEX SKT LH CAP SCR STN M5X10	
206	050-F00400	M4 NUT FLG SER PAS	
208	000-P00312-W	M3X12 MSCR PAN W/FS PAS	
301	NCR-60106UK	WIRE HARNESS FL	(NOT SHOWN)
302	GE-60106UK	WH LAMP FLASH LED	

⑤ ASSY FRONT PANEL (GE-0600UK)

SORRY BUT NO IMAGE AT TIME OF PRINT

ITEM NO.	PART NO.	DESCRIPTION	NOTE
1	GE-0601UK	FRONT PANEL	
2	CTF-0602UK	PANEL BRKT UPPER	
3	CTF-0603UK	PANEL BRKT LOWER	
4	EZT-0603	SIDE BRKT	
6	GE-0606UK	STICKER FRONT PANEL L	
7	GE-0607UK	STICKER FRONT PANEL R	
8	GE-0608UK	PLATE CONN	
9	GE-0609UK	PLATE CONN LOWER	
101	130-013-04040WP	SPEAKER 4OHM 40WATT	
201	050-F00500	M5 NUT FLG SER PAS	
202	068-552016	M5 WSHR 20OD FLT PAS	
203	000-P004216-W	M4X16 MSCR PAN W/FS PAS	
301	GE-60101UK	WH SPEAKER	

⑥ ASSY PTV BASE (GE-0650UK)

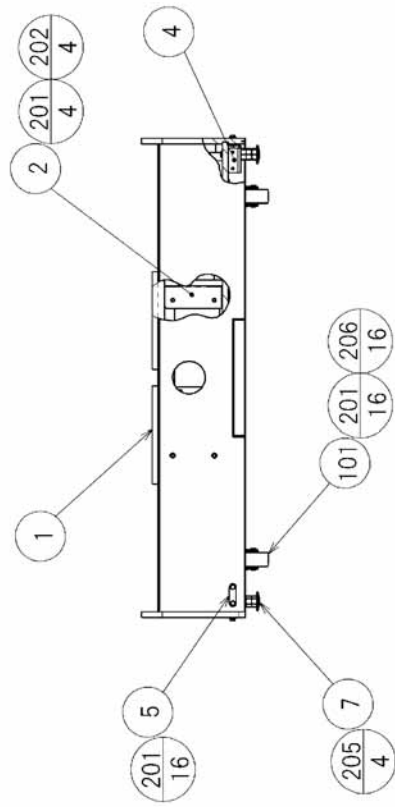
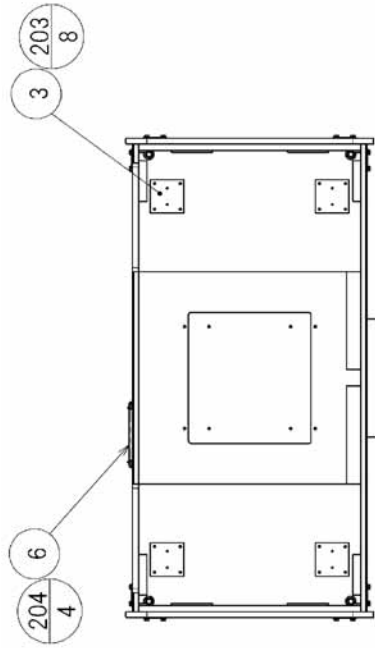
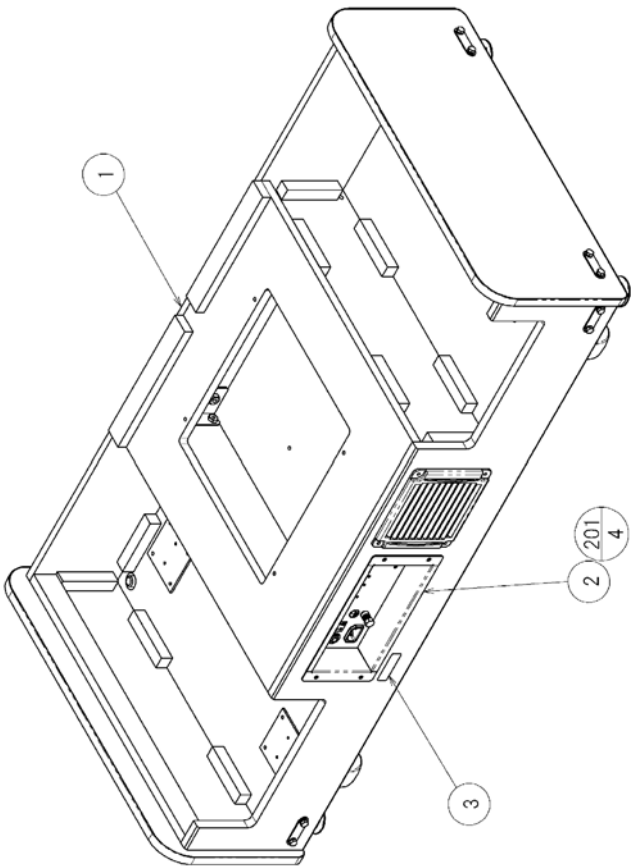

⑥ ASSY PTV BASE (GE-0650UK)

ITEM NO.	PART NO.	DESCRIPTION	NOTE
1	GE-0661UK	PTV BASE	
2	CTF-0662UK	BASE NUT BRKT	
3	SCR-1008UK	NUT PLATE FOR CASTOR	
4	ARC-1006	LEG BRKT	
5	117-5233	PLATE LEG BRKT	
6	253-5460-01	AIR VENT BLACK	
7	601-5699X	LEG ADJ BOLT M16X75 SEGA	
10	GE-0670UK	AC UNIT	
11	GE-0660UK	ASSY XFMR	
101	601-9377	CASTOR FAI=75	
201	030-000630-SB	M6X30 BLT W/S BLK	
202	068-652016	M6 WSHR 20OD FLT PAS	
203	012-P03512-F	N6X1/2 S/TAP FLG PAS	
204	000-T00420-0B	M4X20 MSCR TH BLK	
205	050-H01600	M16 NUT PAS	
206	060-F00600	M6 WSHR FORM A FLT PAS	
207	000-P00425-W	M4 WSHR 16OD FLT PAS	

⑦ ASSY XFMR (GE-0660UK)

SORRY BUT NO IMAGE AT TIME OF PRINT

ITEM NO.	PART NO.	DESCRIPTION	NOTE
1	CTF-0663UK	TRANS BASE	
101	560-LBGH-01UK	XFMR LINDBERGH 230-100V 8A	
201	000-P00412-W	M4X12 MSCR PAN W/FS PAS	
202	068-441616	M4 WSHR 16OD FLT PAS	
301	GE-60037UK	WH AC EXT2 FRONT CABI	

⑧ ASSY AC UNIT (GE-0670UK)

SORRY BUT NO IMAGE AT TIME OF PRINT

ITEM NO.	PART NO.	DESCRIPTION	NOTE
1	GE-0671UK	AC BRKT	
101	EP1382	FILTER SCHAFFNER FN682-10/06	
103	EP1387	IEC INLET & SW BZV01/Z0000/70	
201	000-P00308	M3X8 MSCR PAN PAS	
203	050-F00400	M4 NUT FLG SER PAS	
301	GE-60104UK	WH AC BRKT	

⑨ ASSY MASK (SPX-0530UK)

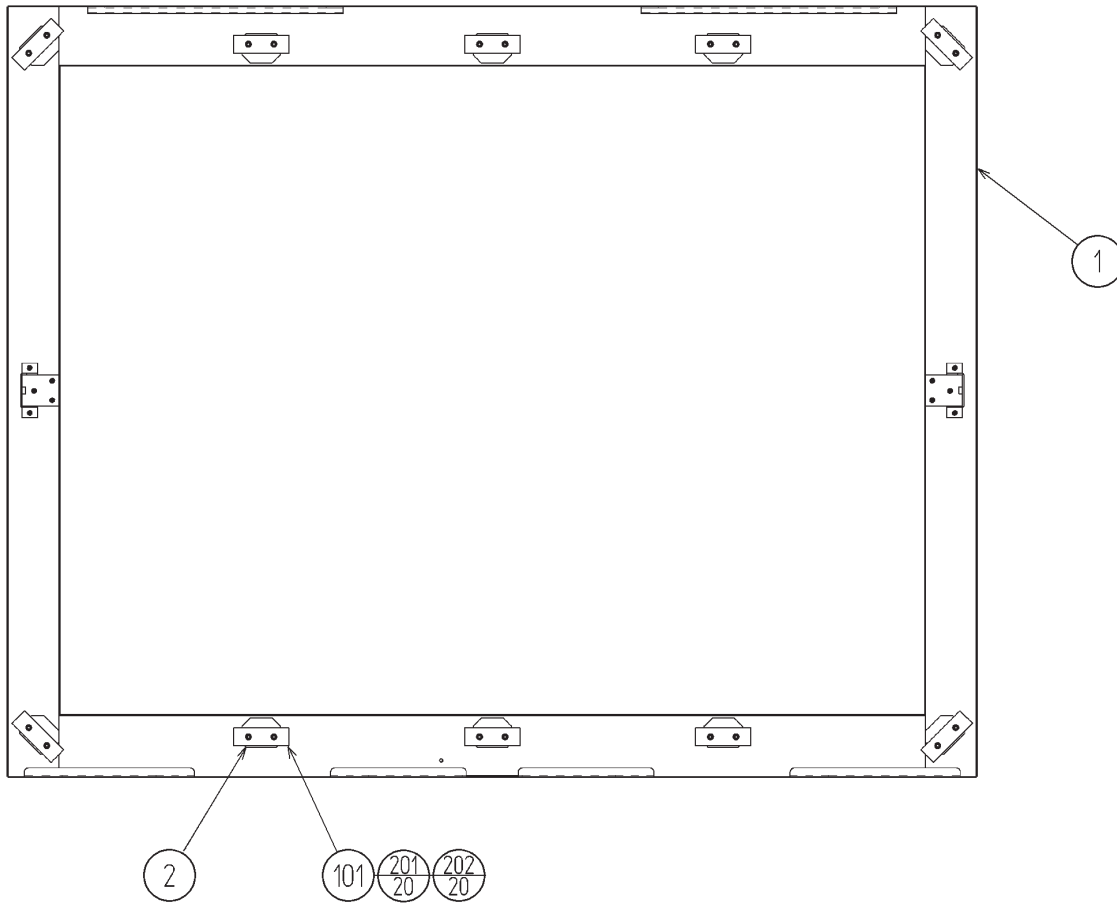

ITEM NO.	PART NO.	DESCRIPTION	NOTE
1	HOD-1151	MASK BASE	
2	JPT-1082	IR COVER	
101	838-13145R02	LED BD GUN SENSOR HOD	
201	`050-U00300	M3 NUT NYLOK PAS	
202	068-330808-PN	M3 WSHR 80D FLT NYLON	
203	050-F00400	M4 NUT FLG SER PAS	
301	SPY-60024	WH MASK SHORT	
302	SPY-60025	WH MASK LONG	

⑩ ASSY FAN AC UK

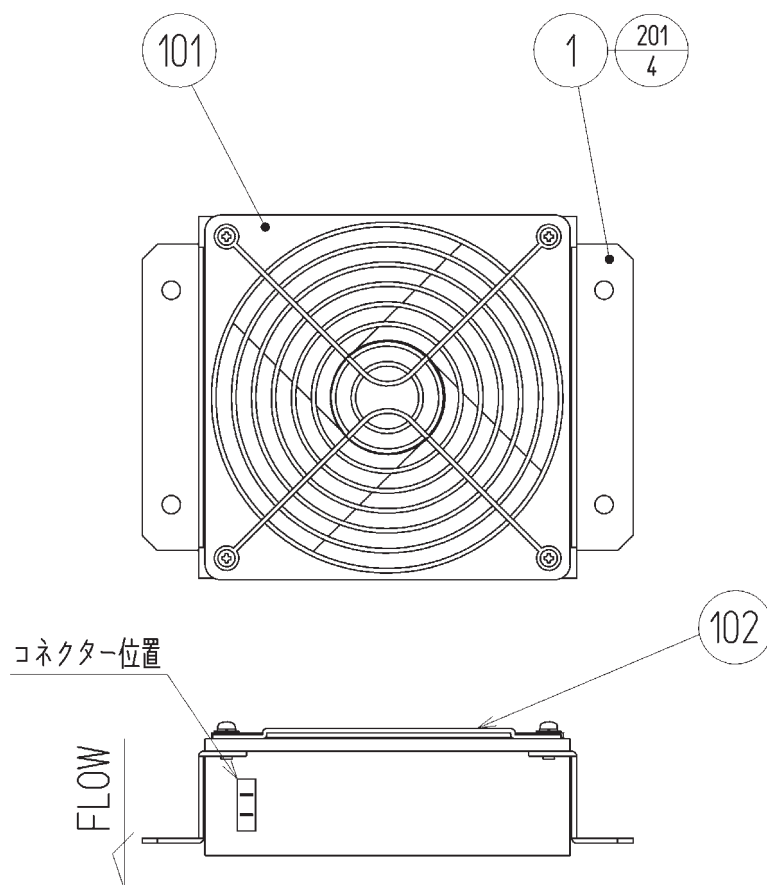

ITEM NO.	PART NO.	DESCRIPTION	NOTE
1	105-5340-01	FAN BRKT LONG	
101	260-0011-02	FAN AC100V 50-60HZ (SP100A-112)	
102	FN1012	FAN GUARD METAL 120MM (FG-12)	
201	000-P00312-W	M3X12 MSCR PAN W/FS PAS	
308	CTF-60019UK	WH AC FAN	

11 ASSY SUB CABI DX (GE-1100UK)

(D1-2)

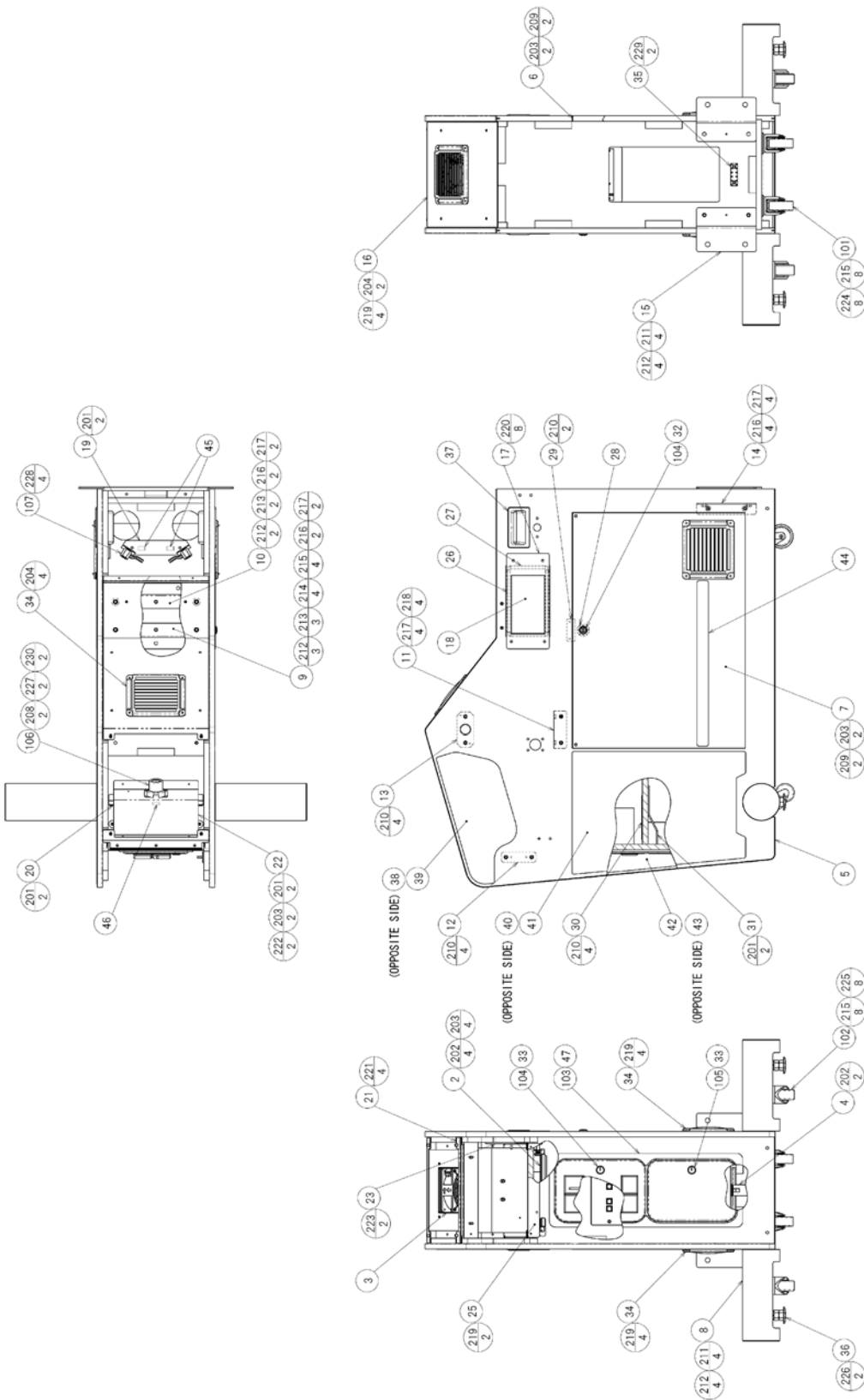

ITEM NO.	PART NO.	DESCRIPTION	NOTE
1	VTS-HOD-D-R	VTS BD HOD	
3	CTF-0665UK	ASSY FAN UNIT AC UK	
5	GE-1101UK	CABINET DX	
6	CTF-1102UK	SIDE DOOR L	
7	CTF-1103UK	SIDE DOOR R	
8	CTF-1106UK	FOOT BASE	
9	CTF-1107UK	PIPE SUPPORT A	
10	CTF-1108UK	PIPE SUPPORT B	
11	CTF-1109UK	PIPE NUT BRKT	
12	CTF-1110UK	PIPE NUT PLATE A	
13	CTF-1111UK	PIPE NUT PLATE B	
14	CTF-1112UK	CORNER BRKT	
15	CTF-1113UK	JOINT BRKT LOWER	
16	CTF-1114UK	CABI TOP LID	
17	GE-1115UK	GLASS HOLDER	
18	GE-1116UK	LAMP GLASS	
19	GE-1117UK	SASH LAMP GLASS	
21	GE-1119UK	CONTROL PANEL HOLDER	
28	117-0062	PLATE LOCK RETAINER SPIKE WASH	
30	DUT-0302UK	COIN PATH PLATE	
32	DP-1167UK	TNG LKG UK	
34	253-5460-01	AIR VENT BLACK	
35	CFB-4003-01UK	EARTH TERMINAL PLATE	
36	601-5699X	LEG ADJUSTER BOLT M16X75 SEGA	
37	253-5396-91	CABINET HANDLE	
38	GE-1124UK	STICKER CABI UPPER L	
39	GE-1125UK	STICKER CABI UPPER R	
40	GE-1126UK	STICKER CABI SIDE L	
41	GE-1127UK	STICKER CABI SIDE R	
42	GE-1128UK	STICKER CABI INSIDE L	
43	GE-1129UK	STICKER CABI INSIDE R	
44	GE-1130UK	STICKER CABI DOOR L	
45	GE-1131UK	STICKER CABI DOOR R	

⑫ ASSY CONTROLLER HOLDER L (GE-1300UK)

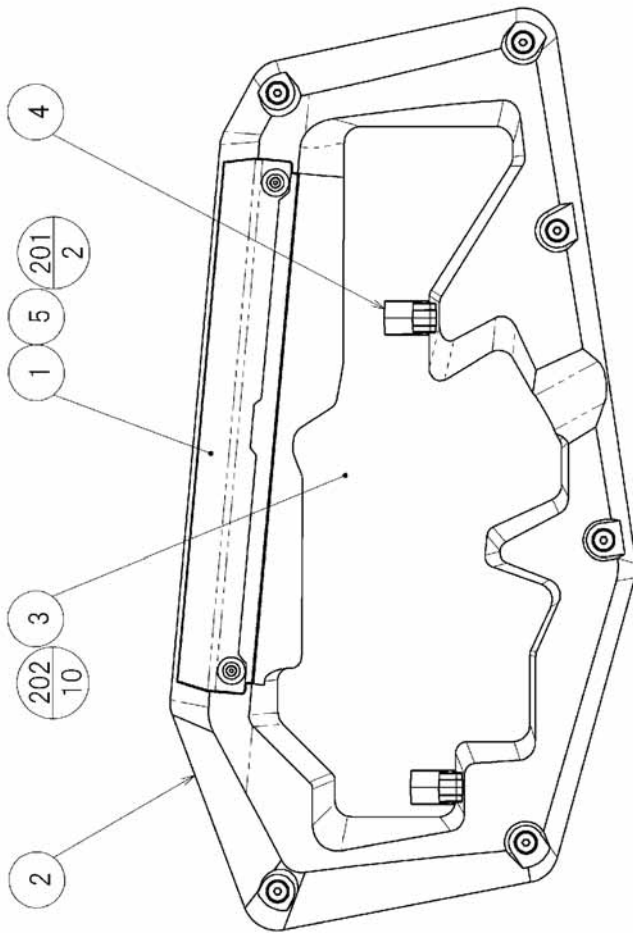

ITEM NO.	PART NO.	DESCRIPTION	NOTE
1	GE-1340UK	ASSY LIGHT HOLDER	
2	CTF-1301	CONTROLLER HOLDER L	
3	GE-1302UK	CONTROLLER HOLDER PLATE	
4	CTF-1303	CONTROLLER HOOK	
5	CTF-1002UK	WASHER CTF	
201	FAS-290037	HEX SKT LH CAP SCR STN M5X20	
202	FAS-120031	TAP SCR P-TITE TH BLK 4X16	
301	GE-60027UK	WH GUN HOLDER LED	

⑬ ASSY HOLDER LIGHT (GE-1340UK)

(D1/2)

18 PARTS LIST

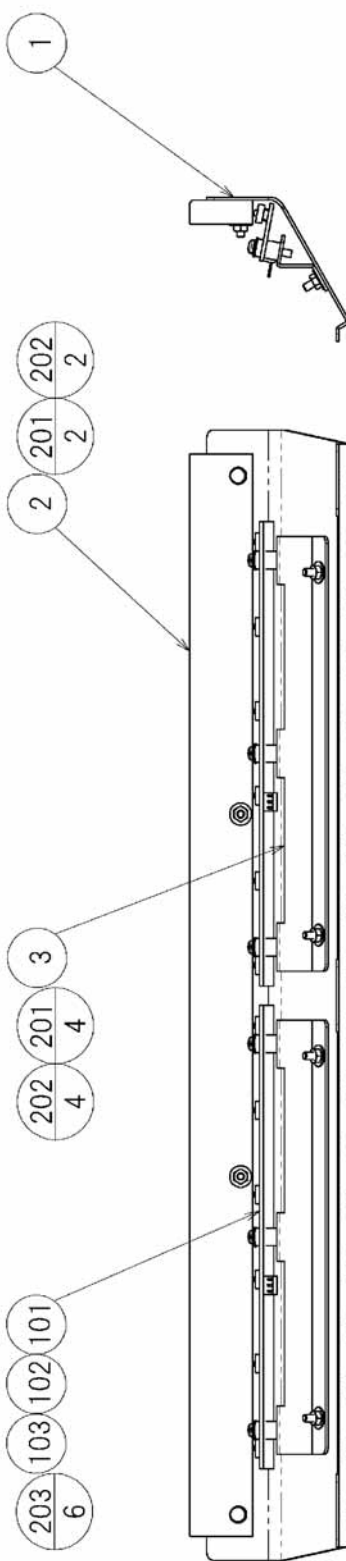

13 ASSY LIGHT HOLDER (GE-1340UK)

(D-2/2)

ITEM NO.	PART NO.	DESCRIPTION	NOTE
1	CTF-1341UK	HOLDER LIGHT COVER	
2	CTF-1342UK	HOLDER LIGHT PLATE	
3	CTF-1343UK	LED BD BRKR	
101	838-14463-BL-UK	LED BAR BD BLUE	
201	050-U00300	M3 NUT NYLOCK PAS	
202	060-F00300	M3 WSHR FORM A FLT PAS	
203	000-P00316-W	M3X16 MSCR PAN W/FS PAS	

14 ASSY CONTROL HOLDER R (GE-1320UK)

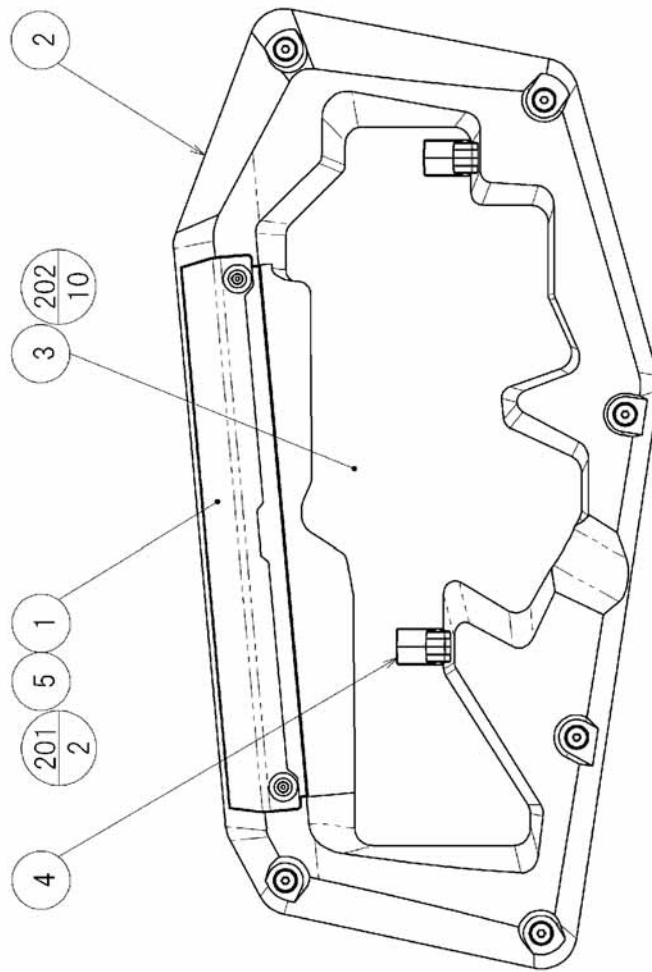

ITEM NO.	PART NO.	DESCRIPTION	NOTE
1	GE-1340UK	ASSY LIGHT HOLDER	
2	CTF-1321	CONTROLLER HOLDER R	
3	GE-1322UK	CONTROLLER HOLDER PLATE	
4	CTF-1303	CONTROLLER HOOK	
5	CTF-1002UK	WASHER CTF	
201	FAS-290037	HEX SKT LH CAP SCR STN M5X20	
202	FAS-120031	TAP SCR P-TITE TH BLK 4X16	
301	GE-60027UK	WH GUN HOLDER LED	

15 ASSY CONTROL PANEL (GE-2000UK)

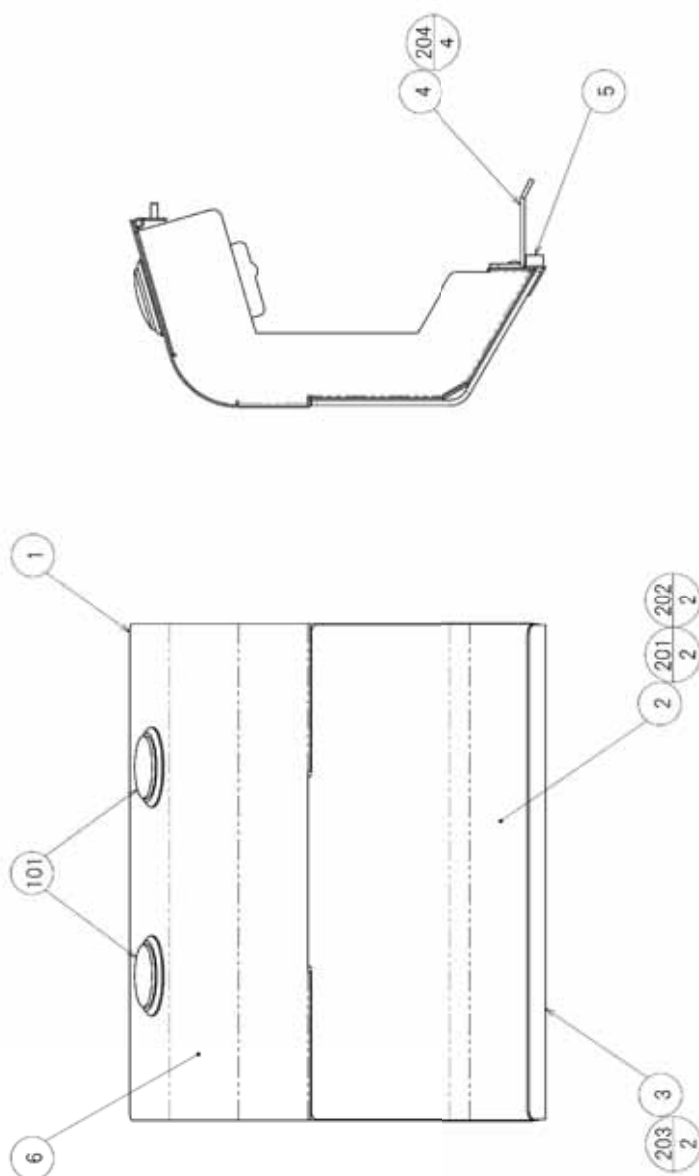

ITEM NO.	PART NO.	DESCRIPTION	NOTE
1	GE-2001UK	CONTROL PANEL BASE	
2	GE-2002UK	WINDOW DOOR WELL	
4	GE-2004UK	BRKT LED	
6	GE-2006UK	STICKER CONTROL PANEL	
101	509-6101	SW PB OBSA-45UM-Y-1FLED-Y-5V	
102	838-14463-BL-UK	LED BAR BD BLUE	
201	050-F00400	M4 NUT FLG SER PAS	
202	068-441616	M4 WSHR 16OD FLT PAS	
205	000-T00412-0B	M4X12 MSCR TH BLK	
206	000-P00312-W	M3X12 MSCR PAN W/FS PAS	
301	GE-60028UK	WH COIN LED	NOT SHOWN
302	GE-60031UK	WH START SW	NOT SHOWN
303	600-9010-44K	WIRE HARNESS EARTH 100MM M4/M4	

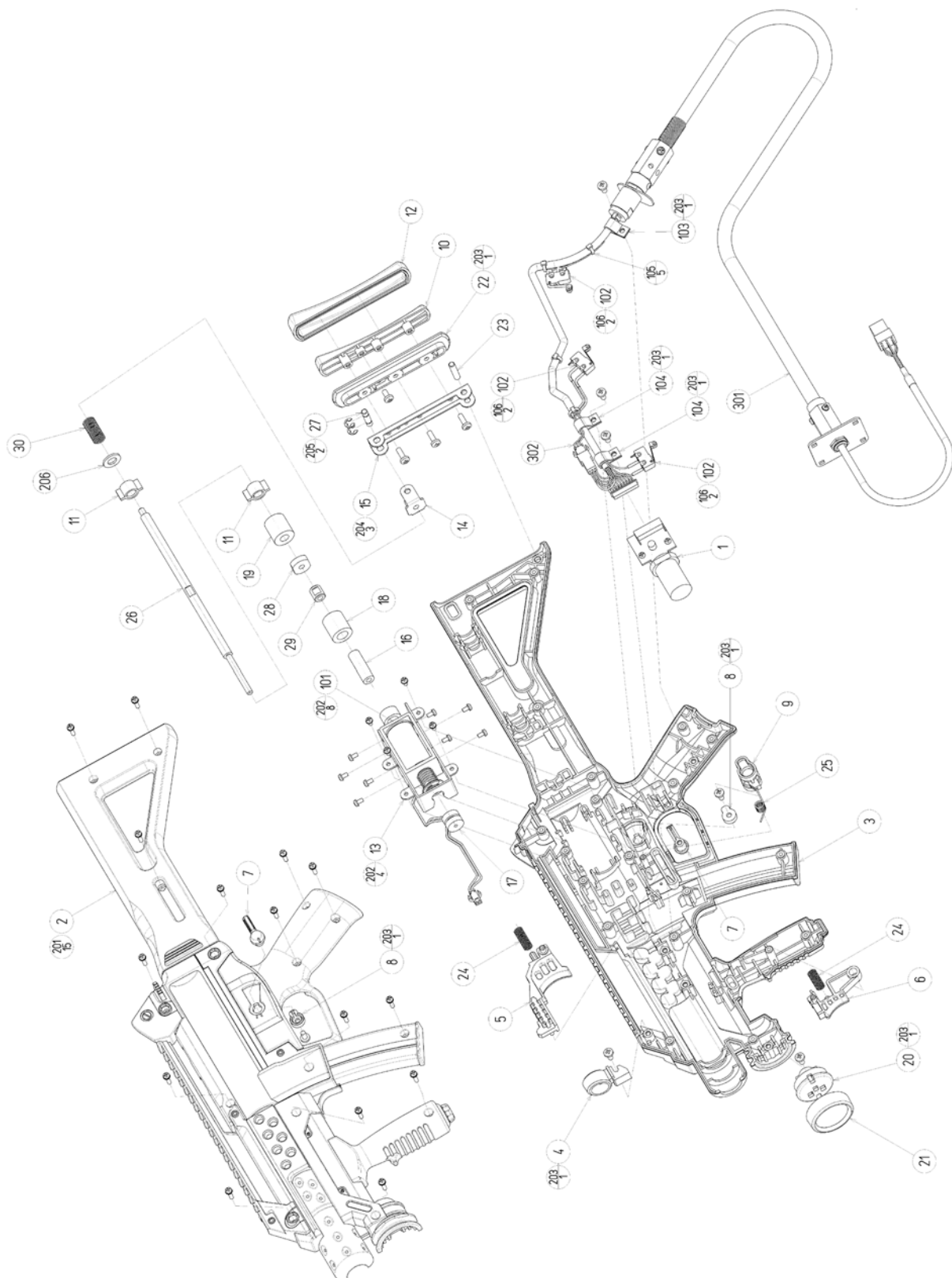

ITEM	PART NUMBER	DESCRIPTION
1	JPT-2030	SENSOR UNIT
2	CTF-2101	COVER L
3	CTF-2102	COVER R
4	CTF-2103	FRONT SIGHT
5	CTF-2104	MAIN TRIGGER
6	CTF-2105	SUB TRIGGER
7	CTF-2106	SELECTOR
8	CTF-2107	SELECTOR HOLDER
9	CTF-2108	SELECTOR JOINT
10	CTF-2109	PAD BASE
11	CTF-2110	BEARING HOLDER
12	CTF-2111	PAD
13	CTF-2112	SOLENOID FRAME
14	CTF-2113	SHAFT JOINT
15	CTF-2114	PAD FRAME
16	CTF-2115	RECOIL DAMPER
17	CTF-2116	SOLENOID DAMPER
18	CTF-2117	SHAFT DAMPER F
19	CTF-2118	SHAFT DAMPER R
20	CTF-2119	CAP BASE
21	CTF-2120	LIGHT CAP
22	CTF-2121	PAD BEZEL
23	CTF-2122	PAD PIN
24	CTF-2123	TRIGGER SPRING
25	CTF-2124	SELECTOR SPRING
26	CTF-2125	SHAFT
27	CTF-2126	JOINT PIN
28	CTF-2127	SHAFT STOPPER
29	CTF-2128	DAMPER BASE
30	CTF-2129	RETURN SPRING
101	124-5097	SOLENOID
102	509-5080	SW MICRO TYPE (SS-5GL2)
103	280-5124-04	NYLON CLAMP NK04
104	280-5124-05	NYLON CLAMP NK05
105	601-0460	PLASTIC TIE BELT 100 M/M
106	310-5029-D20	SUMITUBE F D 20MM
201	FAS-000100	M SCR PH W/SMALL FS BLK M3x12
202	000-P00306-S	M SCR PH W/S M3x6
203	FAS-120029	TAP SCR P-TITE PH 4x8
204	FAS-120030	TAP SCR P-TITE PH BLK 4x12
205	065-E00400	E RING 4MM
206	FAS-600020	FLT WSHR NORM A M8
301	CTF-60032	WH CONTROLLER MAIN EXT
302	CTF-60033	WH CONTROLLER SW EXT

①⑦ SENSOR UNIT (JPT-2030)

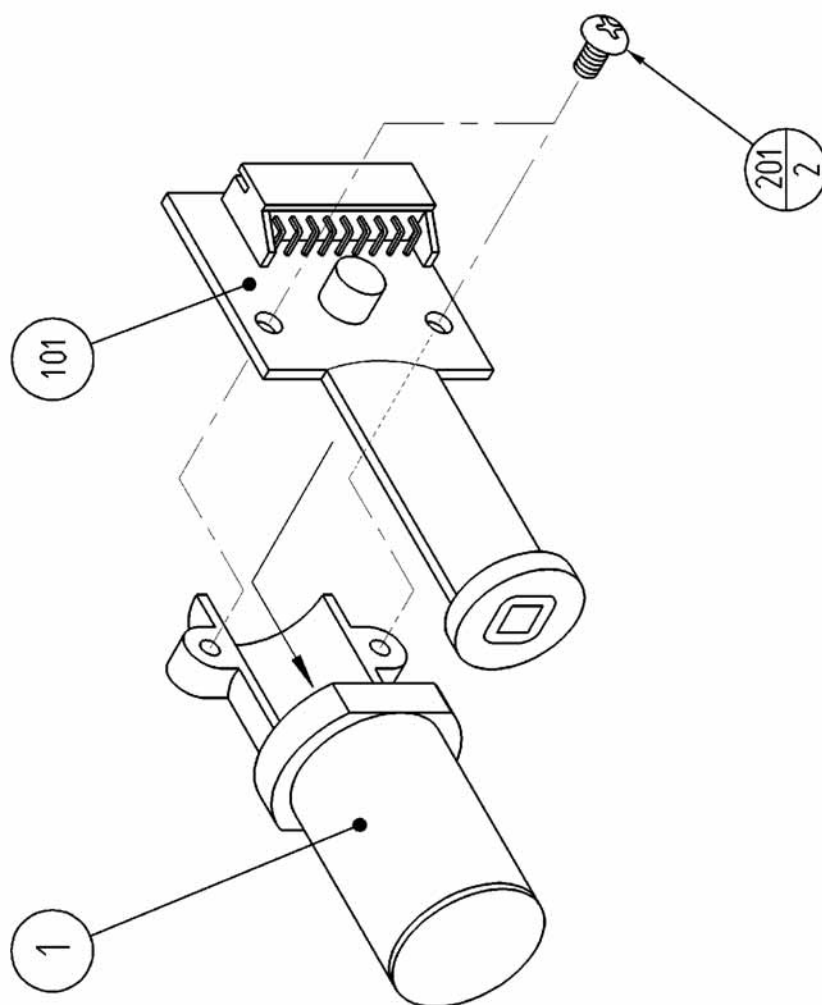

ITEM NO.	PART NO.	DESCRIPTION	NOTE
1	JPT-2031	SENSOR HOLDER	
101	838-13144	SENSOR BD GUN SENSE	
201	013-P00306	TAP SCREW #2 PH 3X6	

18 ASSY MAIN BOARD (GE-4100UK)

SORRY BUT NO IMAGE AT TIME OF PRINT

ITEM NO.	PART NO.	DESCRIPTION	NOTE
1	GE-4001UK	WOODEN BASE MAIN	
2	845-0001D-2	ASSY CASE LBG L 512MB EXP	
5	LB1101	LABEL WARNING BATTERY	
8	LB1111	STICKER PLEASE RECYCLE	
9	610-0727-0029	DVD SOFT KIT CTF EVO	
101	400-5457-91	SW REGU ATX/JVS	
201	000-P00416-W	M4X16 MSCR PAN W/FS PAS	
301	GE-60001UK	WH POWER DC	
302	GE-60016UK	WH AUDIO	
303	600-7009-1800UK	CA VGA 1800MM	
304	600-7141-0100UK	CABLE JVS TYPE A-B 2	

19 ASSY ELEC (GE-4100UK)

SORRY BUT NO IMAGE AT TIME OF PRINT

ITEM NO.	PART NO.	DESCRIPTION	NOTE
1	GE-4101UK	WOODEN BASE ELEC	
2	837-14505	I/O CONTROL BD FOR JVS	
101	838-14515-A0191	SOUND AMP ANALOG IN	
102	838-14551-02UK	DIST BOARD	
103	400-050-012-01	PSU 12VDC 50W MW LPS-50-12	
104	400-075-024-01	PUS 24DC 75W MW LPS-75-24	
105	838-14465R	IC BD GUN SENSE NEW EDIT DX	
109	400-050-024-01	PSU 24VDC 50W MW LPS 50-24	
110	OS1011	PCB FEET RICHCO LCBS-L-5-01	
201	000-P00416-W	M4X16 MSCR PAN W/FS PAS	
202	012-P00325	N4X1" S/TAP PAN PAS	
203	000-P00308-W	M3X8 MSCR PAN W/FS PAS	
204	012-P03516	N6X5/8" S/TAP PAN PAS	
301	GE-60006UK	WH AC DISTRIBUTION	
302	GE-60007UK	WH AC SW REGU	
303	GE-60008UK	WH PCB BOARD DC	
304	GE-60010UK	WH AUDIO ELEC	
305	GE-60011UK	WH SENSOR LED ELEC	
306	GE-60012UK	WH SENSOR CONT ELEC	
307	GE-60013UK	WJ SENSOR FREQ ELEC	
308	GE-60103UK	WH AMP POWER	

ITEM NO.	PART NO.	DESCRIPTION	NOTE
301	GE-60024UK	WH GUN HOLDER	
302	GE-60030UK	WH START & SENSOR CO	
303	GE-60105UK	WH BACK LIGHT LED	

19 WIRE COLOR CODE TABLE

WARNING

The DC power wire color for this product is different from previous SEGA titles.
Working from the previous wire colors will create a high risk of fire.

The color codes for the wires used in the diagrams in the following chapter are as follows.

A	PINK
B	SKY BLUE
C	BROWN
D	PURPLE
E	LIGHT GREEN

Wires other than those of any of the above 5 single colors will be displayed by 2 alphanumeric characters.

1	RED
2	BLUE
3	YELLOW
4	GREEN
5	WHITE
7	ORANGE
8	BLACK
9	GRAY

If the right-hand side numeral of the code is 0, then the wire will be of a single color shown by the left-hand side numeral (see the above).

Note 1: If the right-hand side numeral is not 0, that particular wire has a spiral color code. The left-hand side character shows the base color and the right-hand side one, the spiral color.

<Example> 51.....WHITE/RED



Note 2: The character following the wire color code indicates the size of the wire.

U:	AWG16
K:	AWG18
L:	AWG20
None:	AWG22

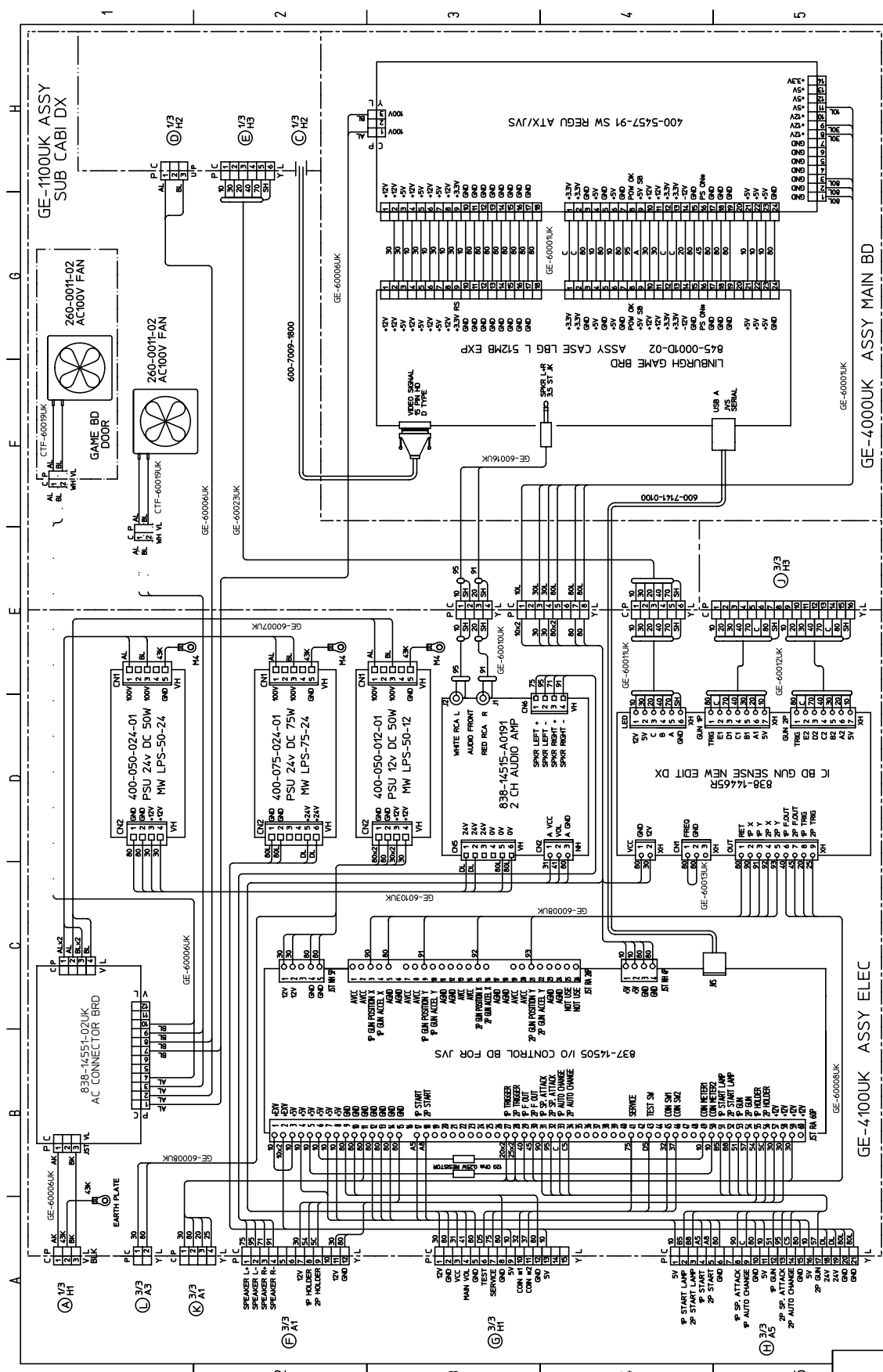

1	LED	8	BLACK	E LIGHT GREEN	DRAWN	CHKD	D/CHKD	APPR	DATE	DESCRIPTION	ORIGINAL SIZE
2	BUFF	9	GREEN							SEGA AMUSEMENTS EUROPE, LTD.	A3
3	YELLOW	10	YELLOW							GHOST SQUAD EVOLUTION	GE-2/3
4	GREEN	11	GREEN								
5	RED	12	RED								
		13	ORANGE								
		14	PURPLE								
		15	BROWN								
		16	WHITE								
		17	ORANGE								
		18	GREEN								
		19	RED								
		20	BLACK								
		21	WHITE								
		22	ORANGE								
		23	GREEN								
		24	RED								
		25	BLACK								
		26	WHITE								
		27	ORANGE								
		28	GREEN								
		29	RED								
		30	BLACK								
		31	WHITE								
		32	ORANGE								
		33	GREEN								
		34	RED								
		35	BLACK								
		36	WHITE								
		37	ORANGE								
		38	GREEN								
		39	RED								
		40	BLACK								
		41	WHITE								
		42	ORANGE								
		43	GREEN								
		44	RED								
		45	BLACK								
		46	WHITE								
		47	ORANGE								
		48	GREEN								
		49	RED								
		50	BLACK								
		51	WHITE								
		52	ORANGE								
		53	GREEN								
		54	RED								
		55	BLACK								
		56	WHITE								
		57	ORANGE								
		58	GREEN								
		59	RED								
		60	BLACK								
		61	WHITE								
		62	ORANGE								
		63	GREEN								
		64	RED								
		65	BLACK								
		66	WHITE								
		67	ORANGE								
		68	GREEN								
		69	RED								
		70	BLACK								
		71	WHITE								
		72	ORANGE								
		73	GREEN								
		74	RED								
		75	BLACK								
		76	WHITE								
		77	ORANGE								
		78	GREEN								
		79	RED								
		80	BLACK								
		81	WHITE								
		82	ORANGE								
		83	GREEN								
		84	RED								
		85	BLACK								
		86	WHITE								
		87	ORANGE								
		88	GREEN								
		89	RED								
		90	BLACK								
		91	WHITE								
		92	ORANGE								
		93	GREEN								
		94	RED								
		95	BLACK								
		96	WHITE								
		97	ORANGE								
		98	GREEN								
		99	RED								
		100	BLACK								

THE DRAWING WILL IN NO WAY BE COPIED.
TO BE RETURNED ON DEMAND.

13/02/07

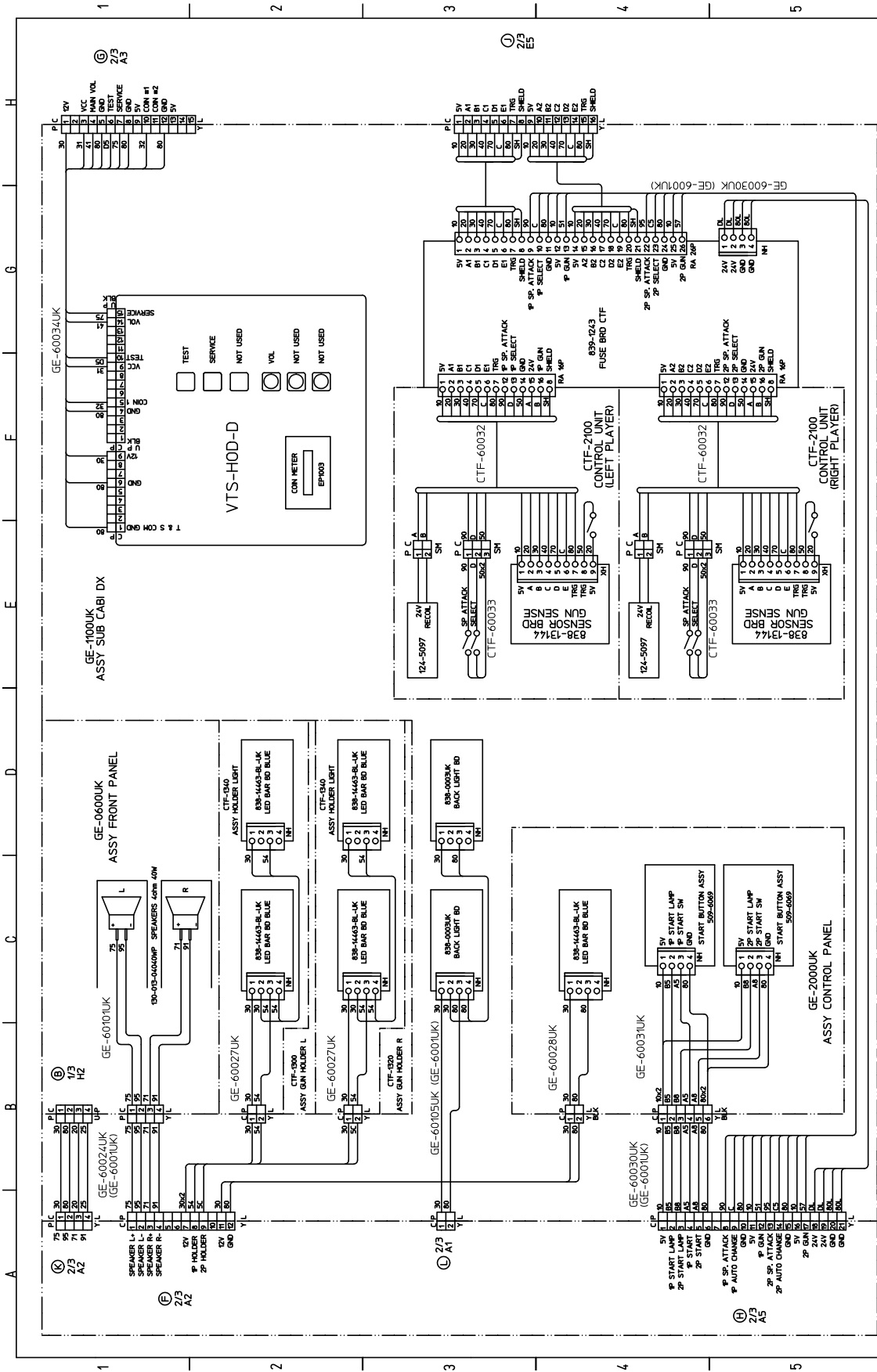

DRAWN		CHKD	TOP LEVEL	ORIGINAL SIZE	
U	AWF 6	MS	XX	GE-00001UK	A3
L	AWF 8				
K	AWF 9				
J	AWF 10				
I	AWF 11				
H	AWF 12				
G	AWF 13				
F	AWF 14				
E	AWF 15				
D	AWF 16				
C	AWF 17				
B	AWF 18				
A	AWF 19				
DATE		13/02/07	XXX/XX/XX	PART NO.	
ALTERNATE				DESCRIPTION	
				GHOST SQUAD EVOLUTION	
				0E-3/3	

THIS DRAWING WILL IN NO WAY BE COPIED, TO BE RETURNED ON DEMAND.