

December 1990
16-40104-101

Williams[®] 

HIGH IMPACT[™]

F O O T B A L L

KIT



**HIGH IMPACT FOOTBALL KIT
INSTALLATION & OPERATIONS
MANUAL**

- * Game Operation & Adjustments
- * Game Testing & Problem Diagnosis
- * Parts Information
- * Reference Diagrams & Schematics

WILLIAMS ELECTRONICS GAMES, INC.
3401 N. CALIFORNIA AVE.
CHICAGO, IL 60618

HIGH IMPACT FOOTBALL!

Experience the earnings impact of Williams' HIGH IMPACT FOOTBALL, and discover why sports video will never be the same again! Only HIGH IMPACT breaks new ground with LIVE ACTION football that delivers all the bone-crunching tackles, circus catches and high energy gridiron excitement.

HIGH IMPACT brings football to life with the energy and strategy of a non-stop highlight film. The reason is Williams' own exclusive digitized graphics technology for on-screen football action that's so real players will feel like suiting up!

With 15 Pro-Action teams to choose from, HIGH IMPACT packs scoring power and continuous buy-in profit punch for 1 to 4 players. There's easy-to-use single "Move" joystick and "Action" button *Superstar™* Controls, with over 40 authentic Offensive plays and Defensive formations to choose from.

This is the single football game you've been waiting for! Players will test their skills to master long-range Bombs, Double Reverses, Half-back Options, Nickel Defense, Zone Coverage, Stunts, Red-Dog Blitz and so much more.

HIGH IMPACT brings you all the action on and off the field - the cheerleaders, the coaches, the outrageous banter of Manic Max™ the deranged play-by-play commentator, the hot dog antics of the players and the cheers and jeers of the fans led by Joe Six-Pack™.

Game Rules:

1 Player on a team: You are Quarterback and Defensive Captain.

2 Players on a team: Players 2 & 3 are Quarterbacks.
 Players 1 & 4 are Defensive Captains.

START/BUYIN: Insert coin(s) and hit START button for each coin.

OFFENSE

PASS: Point Joystick to receiver, hit Action button.

Handoff: Point Joystick to halfback, hit Action button.

Spin Move: Hit Action button & move Joystick up or down.

Jump Move: Hit Action button & move Joystick right or left.

Kick: Tap Action button rapidly to increase distance.

DEFENSE

Select Player To Control: Hit Action button before hike.

Turbo Speed: Hold down Action button for Awesome Speed Burst.

Killer Tackle: Hit Action button.

Interception: Hit Action button for leaping catch.

Block Kick: Hit Action button.

Table of Contents

Section 1: Kit Installation, Operation & Troubleshooting

Safety	1-2
Conversion Instructions	
Inspection.....	1-3
Recommended Tools.....	1-3
Cabinet Modifications.....	1-4
Control Panel Modifications.....	1-4
Template for 2 & 4 player Control Panel Conversions.....	1-5
Installing PC Boards into a JAMMA Game Cabinet.....	1-7
Installing PC Boards into a NON-JAMMA Game Cabinet.....	1-8
Installing the Volume Control.....	1-9
Game Features	
Starting-up.....	1-10
Player Controls.....	1-10
Typical 2 & 4 Player Control Panel Layouts.....	1-11
Control Panel Decal Template.....	1-12
Game Operation-	
Control Switches.....	1-13
Game Adjustment & Diagnostics	
Starting up.....	1-14
Main Test Menu.....	1-14
Diagnostic Tests.....	1-15
Switch Test.....	1-15
DIP Switch Test & Chart.....	1-16
CPU & Sound Tests.....	1-17
Monitor Patterns & Burn-in Tests.....	1-18
Coin Bookkeeping.....	1-19
Game Audits.....	1-20
Game Adjustments.....	1-22
Standard Pricing Chart.....	1-24
Custom Pricing.....	1-25
Utilities.....	1-26
Troubleshooting	1-27

Section 2: Parts

Audio Board Layout.....	2-5
CPU Board Layout.....	2-6

Section 3: Diagrams & Schematics

Audio Board Schematic.....	3-2
CPU Schematic.....	3-3
JAMMA Chart.....	3-19
High Impact Kit Wiring Diagram.....	3-20
High Impact Kit Interboard Wiring Diagram.....	3-21
Coin Switch & Meter Wiring Diagram.....	3-22
Control Panel Template Diagram(s).....	3-23 to 3-26

NOTES:

HIGH IMPACT FOOTBALL KIT

S E C T I O N
one

Installation, Operation
& Troubleshooting

Safety Notices

The following safety hints apply to all kit operators and service personnel. Specific warnings and cautions will be found throughout this manual where they apply. We recommend that you read this page, and also all of Section 1, before preparing your kit for play.

NOTICE: SALVAGED PARTS

Parts salvaged from old games are required to complete your kit. These salvaged parts must operate perfectly; otherwise, the converted game cannot perform properly or safely. Always repair circuit board malfunctions and cabinet damage before conversion is attempted.

NOTICE: POWER SUPPLY

Be sure the power supply from your old game is capable of +5V dc at 5A, -5V dc at 1A and +12V at 1A. These operating voltages are necessary for your kit. Your power supply must be FCC approved.

NOTICE: MONITOR

This kit is not intended for use with X-Y monitors. Suitable monitors have horizontally mounted CRTs and raster electronics with inputs for red, green and blue video, as well as composite Negative sync input.

NOTICE: COIN MECHANISM

Be sure to clean and lubricate your old coin mechanisms. Servicing them is crucial to your game's earning potential and operation.

NOTICE: COIN METERS

Coin meters are not provided with this kit. Wiring information is provided as a convenience to the operator.

NOTICE: SERVICING, INSTALLING

Always turn your game OFF and unplug it before attempting to service or install your kit.

CAUTION

PROPERLY ATTACH ALL CONNECTORS. *Be sure that the connectors on each printed circuit board (PCB) are properly connected. If they do not slip on easily, do not force them. A reversed connector may damage your kit and void the warranty. All connectors are keyed to fit specific pins on each board.*

Conversion Procedure

Inspection

Unpack the materials from the carton and inspect for obvious signs of damage. Use this checklist to be sure your kit is complete.

Part No.	Item	Quantity
() A-8550-1	Pot & Bracket Assembly	1
() C-13234-40004	CPU Y-unit	1
() C-9214-1	Button Assy-Blue	2
() C-9214-4	Button Assy Red	2
() C-9214-5	Button Assy-White	4
() A-13971-40004	Audio Board Assy	1
() H-12758	Audio Board Jumper Cable	1
() H-13257	Sound Pwr/ Spker Cable	1
() H-13724	Player 3 & 4 Cable	1
() H-8865	Volumn Control Cable 18"	1
() H-8866	Volumn Control Cable Assy	1
() 03-8250	Control Panel Cover	1
() 16-40104-101	Manual	1
() 16-9192	Template Control Panel	1
() 16-9192-1	Template Control Panel P2	1
() 16-9192-2	Template Control Panel P3	1
() 16-9192-3	Template Control Panel P4	1
() 20-9222	Palnut 5/8	8
() 20-9319-1	8-way Joystick- Red	2
() 20-9319-9	8-way Joystick- Blue	2
() 20-9457	Button Holder w/Switch	8
() 31-1612-40104	Control Panel Overlay	1
() 31-1613-40104	Marquee	1
() 31-1616-40104	Decal Cabinet Side	1
() 31-1617-40104	Decal Control Panel	1
() 4308-01123-20B	Cairage Bolt 8-32x1-1/4	16
() 5795-10937-18	Ribbon Cable	1
() Assorted Hardware		

Recommended Tools and Supplies

- () black semi-gloss paint
- () electric drill
- () electric screwdriver
- () grease pencil or marker
- () hex driver
- () 180 grit sandpaper or electric sander
- () pliers
- () razor knife
- () soldering iron and solder
- () wire cutters
- () black electrical tape
- () quick-hardening wood putty

Cabinet Modifications

1. Fill in gouges with a good quick-hardening wood putty. Sand cabinet and wipe it clean.
2. Repaint the cabinet with black semi-gloss paint (Games wood grain slides: remove the old decals and clean the glue residue from the old decal before painting). Allow paint to dry completely.
3. Pencil a line roughly at the top of the old graphic. Lightly moisten the cabinet with soapy water. Apply the decal starting at the top and working down. After the decal is in place, use a squeegee and smooth the decal down, taking care to squeeze out the air bubbles. If you miss an air bubble, pop it with a razor blade or a pin and burnish it down. Allow 12 hours for the adhesive in the decals to set. Remove masking.
4. Check the HIGH IMPACT FOOTBALL Kit for an FCC sticker and apply it over the existing sticker on the cabinet.

When Williams Electronics ships a game, it is in compliance with FCC regulations. The FCC sticker is proof. If the sticker is missing or damaged, legal repercussions to the owner or distributor of the game may result. If your game kit does not contain an FCC sticker, call Williams Electronics immediately.

5. Apply the Instructions (Card or Decals) to the CRT viewing glass.

Control Panel Modifications

1. Remove the control panel buttons and joysticks and remove the old vinyl covering.
2. Place the template on the control panel and use it to help you design your control panel. You will need to use the Mounting Template for each player you intend to install.
3. Drill holes as needed for the joysticks and buttons. Plug previous holes with wood blocks, putty, cardboard or epoxy. File the new holes smooth.
4. Carefully remove the backing on the vinyl control panel overlay. Place the overlay on top of the control panel. Prevent air bubbles from getting under the vinyl overlay.

4 - PLAYER CONVERSION KIT

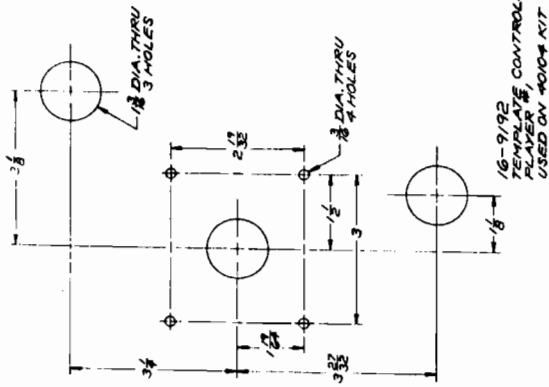

16-9192-1
TEMPLATE CONTROLS
PLAYER #1
USED ON #0104 KIT

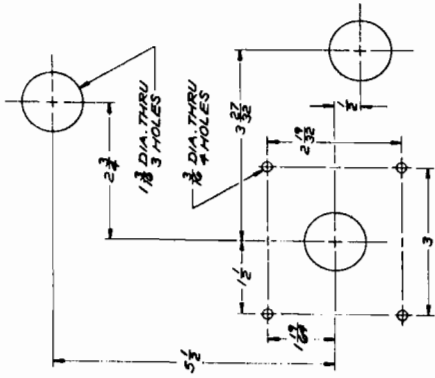

16-9192-1
TEMPLATE CONTROLS
PLAYER #2
USED ON #0104 KIT

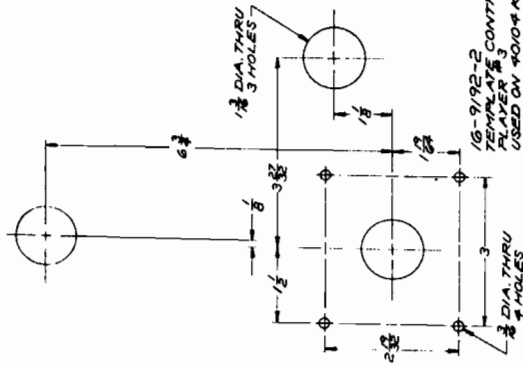

16-9192-2
TEMPLATE CONTROLS
PLAYER #3
USED ON #0104 KIT

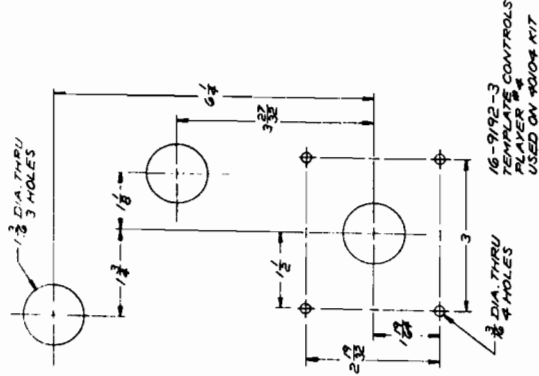

16-9192-3
TEMPLATE CONTROLS
PLAYER #4
USED ON #0104 KIT

2 - PLAYER CONVERSION KIT

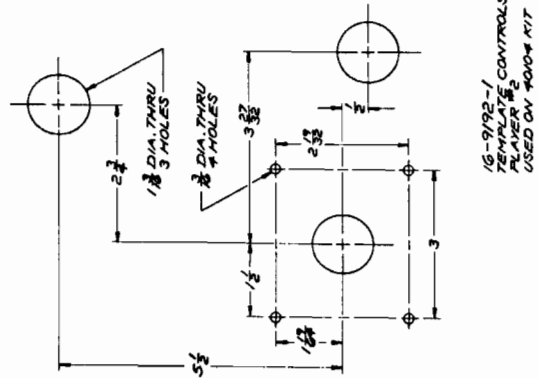

16-9192-1
TEMPLATE CONTROLS
PLAYER #1
USED ON #0104 KIT

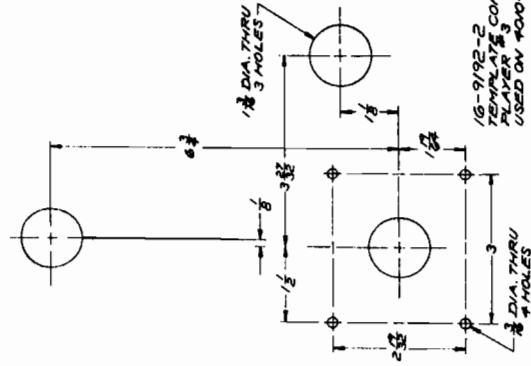

16-9192-2
TEMPLATE CONTROLS
PLAYER #2
USED ON #0104 KIT

5.
 - a) After the overlay is on securely , use a razor knife to cut holes for the buttons and joysticks.
 - b) Position the stickers around the appropriate button locations. Refer to the Typical Control Panel Layout diagrams on the next pages for suggested button and joystick locations.
 - c) Peel the backing from the adhesive on the clear protective overlay. Position the overlay so that it covers the stickers and press it into place. Use a razor knife to cut holes for the joystick and buttons.
6. To mount the pushbuttons and button-holder/switch to the control panel, push the threaded end of the push-button through the control panel from the top so that the threads extend through the back of the control panel. Then, take the white plastic button holder/switch and place it over the pushbutton threads so that the threads extend through the hole in the holder. The blade switch must point toward the back of the cabinet and face you. Secure into place with a pinnut. Repeat for all of the pushbutton switches.
7. To mount the joystick assembly to the control panel first position the switch assembly so that the square base is against the back of the control panel and the hole in the base lines up with the joystick hole in the control panel. Secure the switch assembly to the control panel. Be sure that the blade switch with the red wire (move up) faces the monitor when the control panel is closed. Remove the "E"-ring , white plastic spacer and spring from the joystick shaft. Slip the black plastic washer around the joystick shaft so the rough side faces the handle. Push the shaft through the joystick base from the front of the control panel. After the shaft is through the base, replace the spring, spacer and "E"-ring.

Installing the PC Boards and Wiring into a JAMMA Game Cabinet

Caution

Properly insulate any unused wires within the JAMMA Cable.

1. Disconnect and remove the existing video board in the JAMMA Game Cabinet.
2. Mount the HIGH IMPACT FOOTBALL KIT video board inside the JAMMA Game Cabinet where the old video board was located
3. If you choose to use the JAMMA Cable provided with the kit, unsolder your old JAMMA cable from the speaker, power supply, control panel switches (which may already be disconnected) and coin door. Remove the cable from the game. If you are not going to use the JAMMA Cable provided with the kit, check the JAMMA Cable Connector Chart to be sure your cable is compatible. Leave your power supply chassis as is.
4. Connect the JAMMA Cable to J1 on the HIGH IMPACT FOOTBALL KIT video board. Using the JAMMA Cable Connector Chart for reference, solder the correct JAMMA Cable wires to the speaker, power supply, control panel switches and coin door. Plug the player 1 & 2 JAMMA connectors into their joystick cable connectors.
5.
 - a) For a (4) player conversion, wire the player 3/4 cable from players 3 & 4 control panel joysticks & buttons to connectors 3P & 4P on the CPU Board.
 - b) For a (2) player conversion, ignore above (a) and procede.
6. Connect the player 3 & 4 joystick harness from the CPU board to the joysticks. The 3rd player connector has red wires and is connected from J4 on the CPU board to the player 3 joystick. The 4th player connector has blue wires and is connected from J12 on the CPU board to the player 4 joystick.
7. J6, J7, and J9 on the CPU board are not used.
8. Place the FBI Warning Label on the inside of the cabinet next to the PC boards. Be sure the label is completely visible.

Installing the PC Boards and Wiring into a NON-JAMMA Game Cabinet

NOTE: IF YOU NEED A JAMMA MAIN HARNESS PLEASE CONTACT YOUR AUTHORIZED WILLIAMS' DISTRIBUTOR. (JAMMA MAIN HARNESS PART # H-13411)

1. Disconnect and remove the existing video board in the JAMMA Game Cabinet.
2. Mount the HIGH IMPACT FOOTBALL KIT video board inside the JAMMA Game Cabinet where the old video board was located. Mount the sound board next to the CPU board using the stand-offs and screws provided.
3. Leaving several inches of wire, cut the wires at the coin door, control panel switches (which may already be disconnected) speaker and power supply.
4. Connect the JAMMA Cable to J1 on the HIGH IMPACT FOOTBALL KIT video board. Follow the JAMMA Cable Connector Chart and splice the wires of the JAMMA Cable to the existing wires for the coin door, power supply, speaker and control panel. Be sure all of the spliced wires are well insulated with black electrical tape.
5.
 - a) For a (4) player conversion, wire the player 3/4 cable from players 3 & 4 control panel joysticks & buttons to connectors 3P & 4P on the CPU Board.
 - b) For a (2) player conversion, ignore above (a) and procede.
6. Connect the player 3 & 4 joystick harness from the CPU board to the joysticks. The 3rd player connector has red wires and is connected from J4 on the CPU board to the player 3 joystick. The 4th player connector has blue wires and is connected from J12 on the CPU board to the player 4 joystick.
7. J6, J7, and J9 on the CPU board are not used.
8. Place the FBI Warning Label on the inside of the cabinet next to the PC boards. Be sure the label is completely visible.

Note

The Ribbon Cable may need to be twisted in order to connect it properly.

Note

Be sure all spliced wires are well insulated with black electrical tape.

Caution

Properly insulate any unused wires within the JAMMA Cable.

Installing the Volume Control

1. Mount the volume control, using screws provided, where it is easily accessible. On top of the cash box, or on the wall near sound board are two possible locations.
2. The volume control cable attaches the volume control to the sound board at connector J2. When viewed with the white plastic knob facing you, the shield wire should be soldered to the right lug, the red wire should be soldered to the middle lug, and the black wire should be soldered to the left lug. Refer to Volume Control Diagram.

Volume Control Wiring Diagram

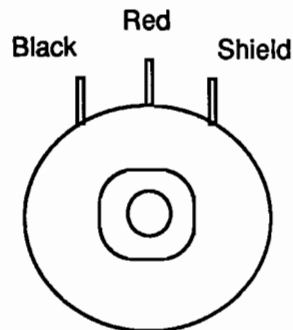

Game Features

Starting Up

Switch on power to the game. A "rug" pattern appears on the crt screen. When the "rug" pattern ends, the screen shows CHECKING SCRATCH RAMS, and then CHECKING ROMS. The next screen shows HIGH IMPACT FOOTBALL REVISION LEVEL, CMOS TEST OK and the COIN SETTING. The game then moves to the attract mode. After the proper coinage has been inserted, the game exits the attract mode and enters the play mode.

**HIGH IMPACT FOOTBALL KIT IS
A 1 TO 4 PLAYER GAME.**

NOTE

HIGH IMPACT FOOTBALL will operate in the Test Mode, when the Test Switch (on the cash box cover) is closed or DIP Switch Bank #2 Switch #8 is closed.

When an error is detected during Start-up Tests, game start-up does not progress, and an error message appears on the screen.

Player Controls

- Each Start button allows (1 to 4) players to begin play or continue play.
- 1 Action button per player.
- 1 Joystick (Move) per player.
- See following page for detailed control panel conversions (2 & 4 player), and a template layout for (2 & 4 player) control panel decal suggestions.

4 Player
HIGH IMPACT FOOTBALL
Control Panel

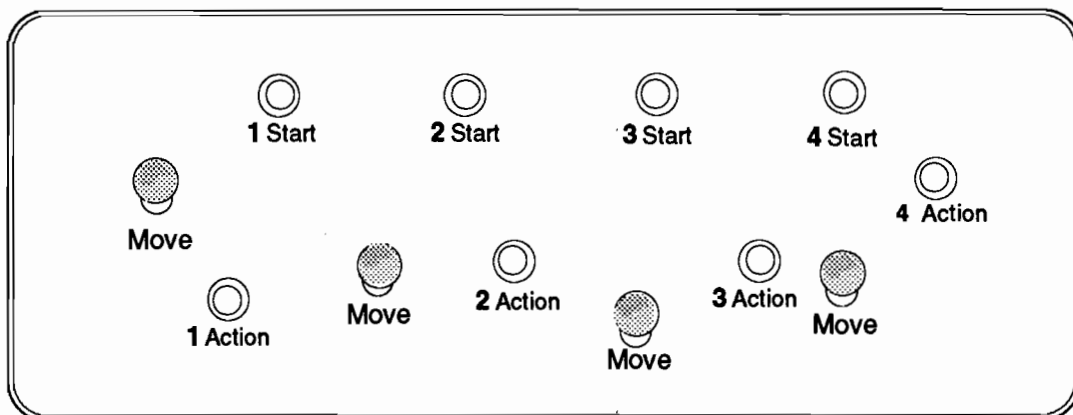

Match (#) with decal number on previous page.

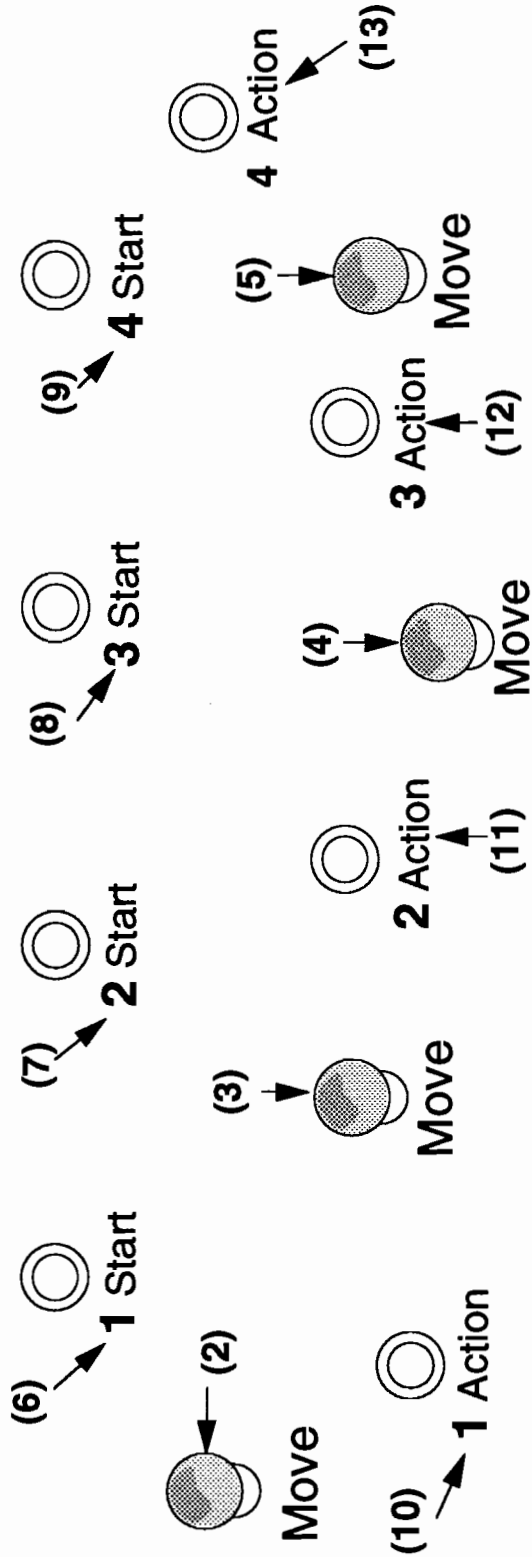

**Suggested Control Panel
Layout for Four Player
Conversion**

Match (#) with decal number on previous page.

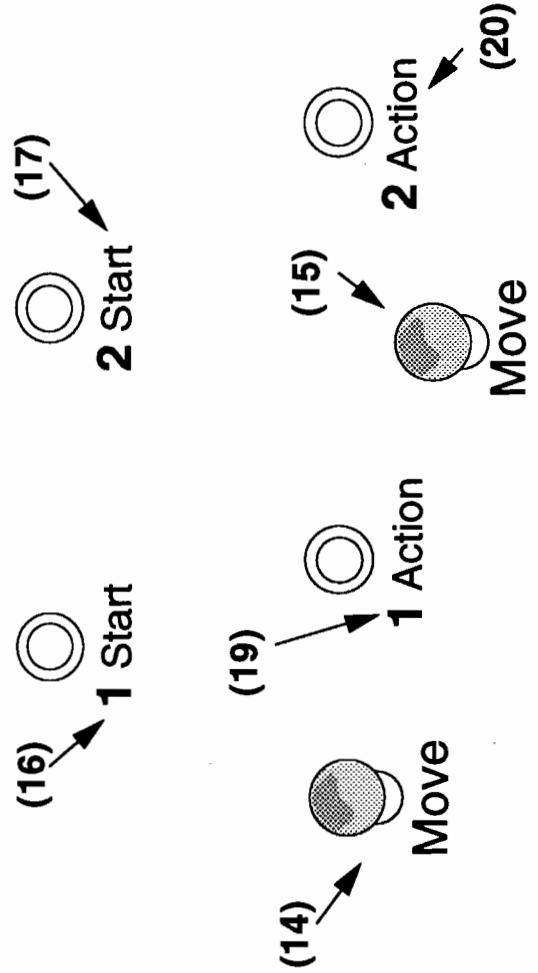

**Suggested Control Panel
Layout for Two Player
Conversion**

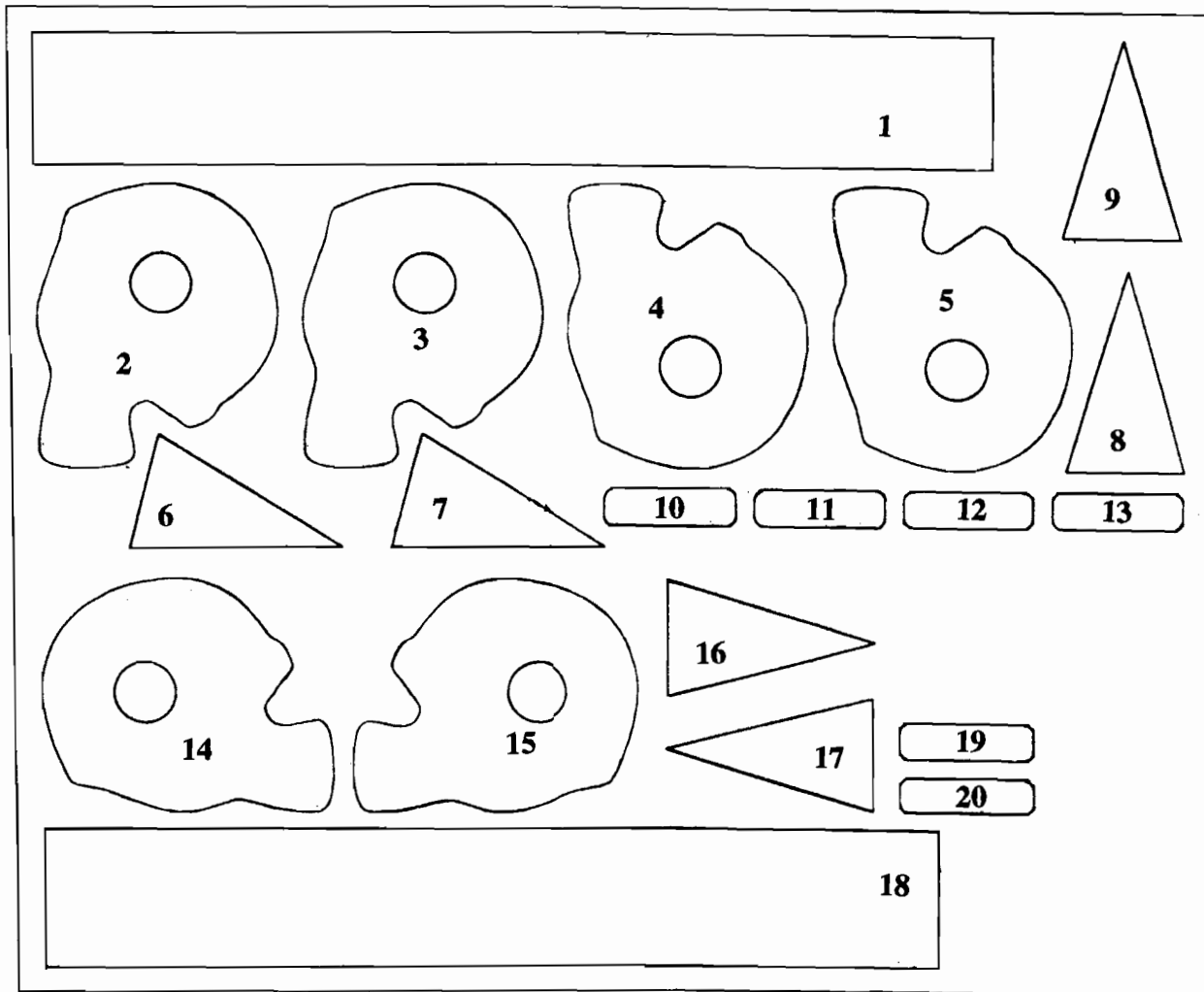

4 PLAYER DECAL SET:

- (1) Four Player Instruction Card
- (2) Player One Defensive Captain (Red)
- (3) Player Two Quarterback (Red)
- (4) Player Three Quarterback (Blue)
- (5) Player Four Defensive Captain (Blue)
- (6) Start Player One (Red)
- (7) Start Player Two (Red)
- (8) Start Player Three (Blue)
- (9) Start Player Four (Blue)
- (10) Action (Red)
- (11) Action (Red)
- (12) Action (Blue)
- (13) Action (Blue)

2 PLAYER DECAL SET:

- (14) Player One Quarterback (Red)
- (15) Player Two Quarterback (Blue)
- (16) Start Player One (Red)
- (17) Start Player Two (Blue)
- (18) Two Player Instruction Card
- (19) Action (Red)
- (20) Action (Blue)

Game Operation

HIGH IMPACT FOOTBALL is a one to four player video game with a color monitor. From the player's perspective, the game has two modes of operation: Ready-to-Play and Play. For the owner/operator, the game has an additional mode of operation called Game Diagnostics and Adjustments.

Control Switches

- The **COIN DOOR SLAM TILT SWITCH** detects any forceful vibrations against the Coin Door. This eliminates pounding for free games. (**OPTIONAL SWITCH**)
- The **VOLUME CONTROL** allows increasing or decreasing the volume level of the game music and speech. For greater profits, set your game's volume level at its maximum.
- The **TEST/DIAGNOSTICS SWITCH** allows you to enter into the game's Diagnostic mode. Move the Test Switch to enter the Diagnostics Mode. To exit this mode, select EXIT TO GAME OVER from the Diagnostics main menu. (**OPTIONAL SWITCH**)
- The **SERVICE CREDIT SWITCH** is a special feature switch that allots credit without affecting the game's bookkeeping total. (**OPTIONAL SWITCH**)

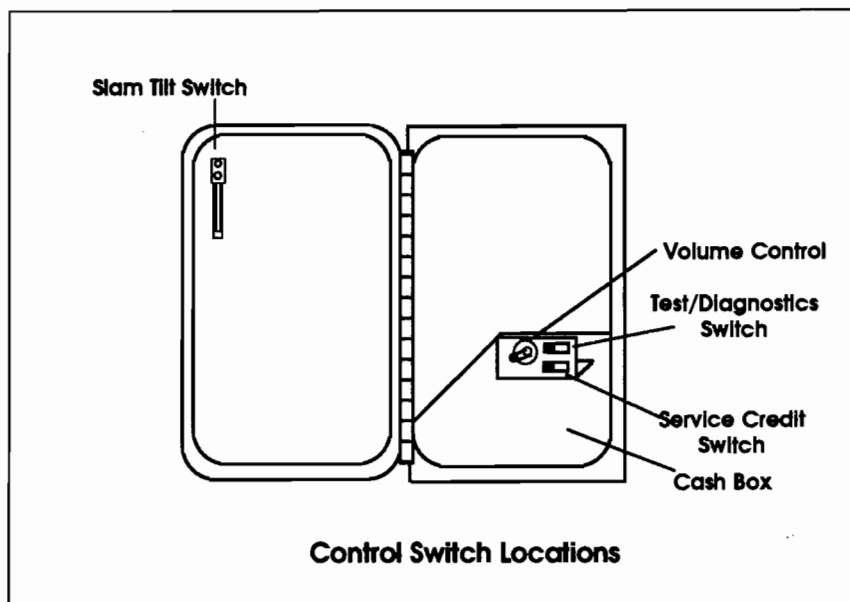

Game Audits, Adjustments & Diagnostics

Operation

All HIGH IMPACT FOOTBALL Game Audits, Adjustments, and Diagnostics are options of the Main Test Menu. Each option, in turn, has its own menu, listing several choices that you may act upon as desired.

Move the Test Switch (on the cashbox lid panel) to activate the HIGH IMPACT FOOTBALL Adjustments and Diagnostics. Main Test Menu (shown below) then appears. Game adjustments, bookkeeping, and diagnostics are all accessible from this menu.

Move any joystick up or down to cycle through the menu options. Notice that the options are highlighted in sequence. Selecting a desired option requires it to be highlighted. To activate the selected option, press any button.

The Main Test Menu lists six options.

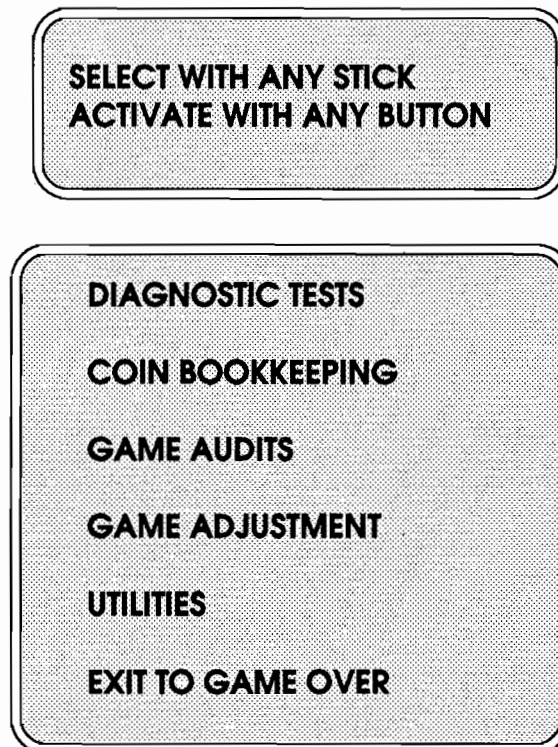

Main Test Menu

DIAGNOSTIC TESTS

To enter the Diagnostic Tests from the Main Test Menu, move any joystick to select (highlight) the Diagnostic Test option, and press any button to activate the option. The Diagnostic Tests Menu lists seven options.

**SELECT WITH ANY STICK
ACTIVATE WITH ANY BUTTON**

**SWITCH TEST
DIP SWITCH TEST
CPU BOARD TEST
SOUND BOARD TEST
MONITOR PATTERNS
BURN-IN TEST
RETURN TO MAIN MENU**

Diagnostic Test Menu

Switch Test

The Switch Test allows the operator to test the switches on the control panel and the coin door.

Select the Switch Test by using any joystick to highlight the Switch Test option; then, press any button to activate it. The top of the screen shows a layout of the control panel and the bottom of the screen lists the coin door switches. Pressing a switch causes the corresponding switch location on the screen to light. Release the switch and the screen returns to normal.

Select the RETURN TO MAIN MENU option to return to the Diagnostic Test Menu.

DIP Switch Test

The DIP Switch Test allows the operator to check the position of the two 8-position DIP switches on the CPU Board. The operator can also change the setting of each position of each DIP switch during this mode.

Select the DIP Switch Test by moving any joystick to highlight the DIP Switch Test option; then, press any control panel button to activate the test. The screen displays a layout of the DIP switches and their current settings.

To change the setting of either DIP switch, press the switch position (SW1 - SW8) to the desired setting (ON from OFF, or vice versa). Check the screen to verify that the switch now shows the setting desired.

Press any control panel button to return to the Diagnostic Test Menu.

DIP Switch 1 Settings Table

	SW 1	SW 2	SW 3	SW 4	SW 5	SW 6	SW 7	SW 8
4 Player 2 Player	Off * On							
CMOS Coinage DIP Switch Coinage		On Off *						
Coin Settings								
USA 1	Ger 1	Fr 1	Off *	Off *	Off *			
USA 2	Ger 2	Fr 2	On	Off	Off			
USA 3	Ger 3	Fr 3	Off	On	Off			
USA 4	Ger 4	Fr 4	On	On	Off			
USA ECA	Ger ECA	Fr ECA	Off	Off	On			
NU	NU	NU	On	Off	On			
NU	NU	NU	Off	On	On			
Free Play	Free Play	Free Play	On	On	On			
Not Used						Off *	Off *	Off *

DIP Switch 2 Settings Table

	SW1	SW2	SW3	SW4	SW5	SW6	SW7	SW8
USA	Off *	Off *						
German	On	Off						
French	Off	On						
Not Used	On	On						
Not Used			Off *					
One Counter Two Counters				Off * On				
Not Used								
Not Used								
Test Switch Game Mode Test Mode								Off * On

* Indicates Factory Setting

NOTE

As soon as a faulty chip is detected, the CPU Test stops. The remaining chips are not tested.

CPU Board Test

The CPU Board Test (much like the Start-up Test) allows the operator to check the RAMs and ROMs.

Select the CPU Board Test with any stick; then, press any button to activate the automatic test of the CPU Board's RAMs and ROMs. When this test is activated, a "rug" pattern appears on the screen. The screen then changes to show the layout of the RAMs, and ROMs on the CPU. Any chip that is shown as black with a white outline is part of the CPU and should turn either red or green during the CPU Test. Any chip that is shown as gray with a white outline is not installed in the game. During the test, chips are good, if they turn green; they are faulty, if they turn red.

Sound Board Test

The Sound Test allows listening to some of the sounds that HIGH IMPACT FOOTBALL is capable of producing. This test also emits a tone for each fault that is detected.

Select the Sound Board Test with any stick; then, press any button to activate the test. The screen displays two test options:

GENERAL TEST analyzes the sound circuitry. A successful test causes a single "tone" to sound. Detection of a fault causes a series of tones to sound. When no tone sounds, this also indicates a Sound Board problem.

PLAY SOUNDS tests synthesized & digitized sounds from the Sound Board. Advance to the next sound by moving any stick, and press any button to return to the Sound Test Menu.

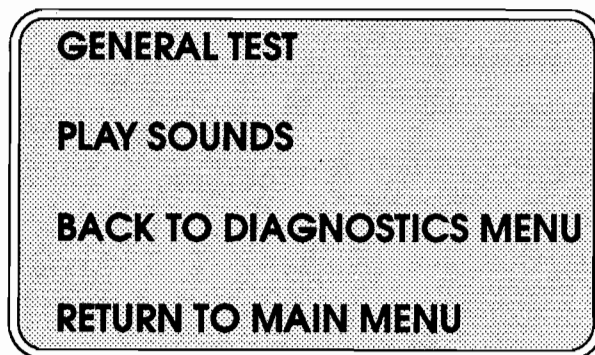

Sound Test Menu

Monitor Patterns

The Monitor Patterns Test provides a menu for testing the monitor.

Move any stick to select a test; press any button to activate the test.

**SELECT WITH ANY STICK
ACTIVATE WITH ANY BUTTON**

**RED SCREEN
GREEN SCREEN
BLUE SCREEN
COLOR BARS
CROSSHATCH PATTERNS
BACK TO DIAGNOSTICS MENU
RETURN TO MAIN MENU**

Monitor Pattern Menu

The **RED**, **GREEN**, and **BLUE SCREEN** tests fill the screen with either red, green or blue.

The **COLOR BARS** test fills the screen with several gradiated colors to help with red, green and, blue level adjustments. Each color should appear sharp and clear.

The **CROSSHATCH PATTERNS** test fills the screen with a grid and a series of dots. The grid and the dots should be clear. The dots should appear round.

If any of the Monitor Pattern Tests shows a need for adjustment, use the proper white knobs on the Monitor Board.

Select Monitor Patterns Menu with any stick, and press any button to activate. From this menu, select RETURN TO MAIN MENU with any stick and activate with any button.

Burn-in Test

The Burn-in Test continually repeats the CPU Board Test. Move any any stick to select the Burn-in Test; then, press any button to activate the test. When the Burn-in Test detects an error, the test stops and displays an error message on the screen. The fourth page of the Audit Table specifies the number of Burn-in cycles successfully completed. Use this test to find intermittent CPU problems.

To exit this test, switch off the game; then, switch it on again.

COIN BOOKKEEPING

To enter the Coin Bookkeeping from the Main Test Menu, move any stick to select the Coin Bookkeeping option; then, press any button to activate it.

The Coin Bookkeeping Table records the coinbox totals and game play counters. The left side of the table names the bookkeeping item; the right side shows the number of coins, credits, or plays for each item.

LEFT SLOT COINS	0
RIGHT SLOT COINS	0
THIRD SLOT COINS	0
FOURTH SLOT COINS	0
SERVICE CREDITS	0
PAID CREDITS	0
TOTAL PLAYS	0
PLAYS UNTIL HIGH SCORE RESET	5000

MORE DETAILED DATA
RETURN TO MAIN MENU

Coin Bookkeeping Table

To exit Coin Bookkeeping, move any stick to select RETURN TO MAIN MENU; then, press any button to activate it.

LEFT SLOT COINS	0
RIGHT SLOT COINS	0
THIRD SLOT COINS	0
FOURTH SLOT COINS	0
TOTAL COLLECTIONS	0

CLEAR COIN METERS
RETURN TO MAIN MENU

Total Collection Table

GAME AUDITS

To enter Game Audits from the Main Test Menu, move any stick to select the Game Audits option; then, press any button to activate it. To advance to the next (or return to the previous) page of the Game Audit Table, move any joystick to select either "Next Audit Page", or "Previous Audit Page"; then, press any control panel button to change the page.

The Game Audits Table records the game play statistics. The left side of the table names the Audit item; the right side shows the amount of play.

TOTAL GAME UPTIME	0
TOTAL PLAY TIME	0
TIME 1 PLAYER ONLY	0
TIME 2 PLAYER SIMULTANEOUS	0
TIME 3 PLAYER SIMULTANEOUS	0
TIME 4 PLAYER SIMULTANEOUS	0

NEXT AUDIT PAGE
RETURN TO MAIN MENU

PAGE 1 OF AUDIT TABLE

TOTAL PLAYS	0
1 PLAYER GAME STARTS	0
2 PLAYER GAME STARTS	0
3 PLAYER GAME STARTS	0
4 PLAYER GAME STARTS	0
CONTINUES OFFERED	0
CONTINUES TAKEN	0
CONTINUES REFUSED	0
GAMES PLAYED TO COMPLETION	0

NEXT AUDIT PAGE
PREVIOUS AUDIT PAGE
RETURN TO MAIN MENU

PAGE 2 OF AUDIT TABLE

GAME AUDITS CONTINUED

LEFT TEAM TOUCHDOWNS	0
RIGHT TEAM TOUCHDOWNS	0
PASSES ATTEMPTED	0
PASSES COMPLETED	0
SAFTIES	0
HUMAN FIELD GOAL ATTEMPTS	0
HUMAN FIELD GOAL COMPLETIONS	0
HUMAN EXTRA POINT ATTEMPTS	0
HUMAN EXTRA POINT COMPLETIONS	0
NEXT AUDIT PAGE	
PREVIOUS AUDIT PAGE	
RETURN TO MAIN MENU	

PAGE 3 OF AUDIT TABLE

HUMAN INTERCEPTIONS	0
DRONE INTERCEPTIONS	0
BURN-IN CYCLES SUCCESSFULLY COMPLETED	0
PREVIOUS AUDIT PAGE	
RETURN TO MAIN MENU	

PAGE 4 OF AUDIT TABLE

To exit the Game Audit Table , move any stick to select RETURN TO MAIN MENU; then, press any button to activate it.

GAME ADJUSTMENTS

Move any joystick to select the Game Adjustment option on the Main Test Menu; then, press any button to activate it.

The Game Adjustments option allows the owner/operator to change the Game Pricing and Game Difficulty.

The Game Adjustment Menu offers several choices. Each choice has its own menu. Move the left joystick to select your choice to be changed from the Game Adjustments Menu; then, move right joystick to activate that choice. On the next menu screen, move the left joystick to select the item you wish to modify; then, move the right to activate that item. If the activated item only provides a setting choice, move any joystick to change the current setting to the desired value; then, press any button to lock in the desired value. Moving the joystick up increases the setting value shown on the screen. Moving the joystick down causes the value shown on the screen to decrease.

**SELECT WITH ANY STICK
ACTIVATE WITH ANY BUTTON**

**RETURN TO MAIN MENU
CREDIT TIMER
ATTRACT MODE SOUNDS
GAME CLOCK SPEED
STANDARD PRICING
CUSTOM PRICING
GAME DIFFICULTY
FREE PLAY
RETURN TO MAIN MENU**

Game Adjustment Menu

**Note, Game Adjustments
are explained in more
detail on the following
page.**

Credit Timer

Controls the speed of the player credit timer. The settings for the adjustment are:

- Slow
- Medium (factory)
- Fast

Attract Mode Sounds

Determines whether the game will make sounds in the attract mode. The settings for the adjustment are:

- Yes (factory)
- No

Game Clock Speed

Allows the operator to adjust the speed at which the game clock will countdown. The settings for the adjustment are:

- Slow
- Medium (factory)
- Fast

Standard Pricing

Standard Pricing allows the operator to choose any of the "Standard" selections for the Standard Pricing Table.

Custom Pricing

Custom Pricing allows the operator to install pricing other than that of the Standard Pricing Table. Custom Pricing also allows the operator to select the maximum amount of credits per game, the amount of credits required to start a game, and the amount of credits required to continue a game. This option is being adjusted from the Dip Switch Settings.

Game Difficulty

Game Difficulty allows the operator to select the difficulty level of the game. The settings for the adjustment are:

- Easy
- Medium (factory)
- Hard

Free Play

This option allows the operator to select free play. The settings for the adjustment are:

- No (factory)
- Yes

HIGH IMPACT FOOTBALL Standard Pricing Table

NAME	SETTING Credit/Coin	LEFT CHUTE	CENTER CHUTE	RIGHT CHUTE	FOURTH CHUTE
USA 1	1/25¢	25¢		25¢	
USA 2	1/50¢	25¢		25¢	
USA 3	1/50¢, 3/\$1.00	25¢		25¢	
USA 4	1/50¢, 4/\$1.00	25¢		25¢	
USA ECA	1/25¢, 4/\$1.00	\$ 1.00	10¢	25¢	5¢
German 1	1/1 DM, 6/5 DM	1 DM		5 DM	
German 2	1/1 DM, 7/5 DM	1 DM		5 DM	
German 3	1/1 DM, 8/5 DM	1 DM		5 DM	
German 4	1/1 DM, 5/5 DM	1 DM		5 DM	
German ECA	1/1 DM, 2/2 DM, 6/5 DM	5DM	1DM	2DM	
France 1	2/5 F, 5/10 F	5 F		10 F	
France 2	2/5 F, 4/10 F	5 F		10 F	
France 3	1/5 F, 3/10 F	5 F		10 F	
France 4	1/5 F, 2/10 F	5 F		10 F	
France ECA	1/3 X 1 F, 2/5 F, 5/2 X 5 F	1F	10F	5F	
Swiss	1/1 F, 6/5 F	1 F		5 F	
Italy	1/500 Lire	500 Lire		500 Lire	
UK 1	1/20 P, 3/50 P	20 P		50 P	
UK ECA	1/30 P, 2/50 P, 4/£1.00	£1.00	20P	50 P	10 P
Spain 1	1/25 Peseta, 5/100 Peseta	25 Peseta		100 Peseta	
Japan 1	1/100 Yen	100 Yen		100 Yen	

If option desired is not shown above, use custom pricing .

GAME ADJUSTMENTS CONTINUED CUSTOM PRICING

SELECT WITH ANY STICK
ACTIVATE WITH ANY BUTTON

(1) LEFT CHUTE UNITS
(1) RIGHT CHUTE UNITS
(1) THIRD CHUTE UNITS
(1) FOURTH CHUTE UNITS
(2) UNITS/CREDIT
(3) UNITS/BONUS
(4) MINIMUM UNITS REQUIRED
(5) CREDITS TO START
(6) CREDITS TO CONTINUE
(7) COINS PER DOLLAR
MAXIMUM CREDITS
RETURN TO ADJ. MENU

- (1) Coins inserted accumulate units. This adjustment specifies the number of units given for each coin in the fourth chute (see "units/credit").
- (2) This is the number of coin units required to buy one credit.
- (3) One bonus credit is awarded after this many coin units have accumulated.
- (4) No credits will be awarded until this many coin units have accumulated.
- (5) Each player needs this many credits to begin a game.
- (6) Each player needs this many credits to continue a game.
- (7) The detailed bookkeeping screen shows total collections based on this many coins per dollar. (Set to zero to disable the display of money totals)
- (8) This is the limit for the credits counter. Additional coins inserted will be lost. (factory setting: 30)

UTILITIES

On the MainTest Menu, move any joystick to select the Utilities option; then, press any control panel button to activate it.

The Utilities option allows the owner/operator to clear the game's bookkeeping memory and to install a custom message.

**SELECT WITH ANY STICK
ACTIVATE WITH ANY BUTTON**

SET OPERATOR MESSAGE

CLEAR CREDITS

CLEAR COIN COUNTERS

CLEAR GAME AUDITS

RESET HIGH SCORE

DEFAULT ADJUSTMENTS

FULL FACTORY RESTORE

RETURN TO MAIN MENU

Utilities Menu

Move any joystick to select an item from the Utilities Menu; then, press any control panel button to activate that item. After an item has been activated, you are given the option of resetting the item or not. For example;

**CLEAR CREDITS
ARE YOU SURE ?**

**YES
NO**

Move any joystick to choose YES or NO; then, press any control panel button to lock in your choice and to return to the Utilities Menu.

To exit Utilities, move any joystick to select RETURN TO MAIN MENU; then, press any control panel button to activate it.

Troubleshooting

Problem	Possible Solution
NO PICTURE OR DISTORTED PICTURE.	Check for faulty video board or monitor. Check for disconnected video signal cable.
TURN GAME ON & NOTHING HAPPENS	Check line fuse. Check for +5V dc at pins C, D, 3, and 4 of the JAMMA Connector.
NO SOUND	Check the speaker and speaker connection to pins L and 10 on JAMMA Connector. Check volume control setting. Check for +12V dc at pins F and 6 on the JAMMA Connector. Check interboard wiring from CPU Board to Sound Board.
NO GENERAL ILLUMINATION	Check the 1 A., S-B fuse on the the bottom of the cabinet below the coin box.
MOVE JOYSTICK, BUT PLAYER DOES NOT MOVE	Check for open wires between Joystick and CPU Board. Check for contamination on joystick switch contacts and CPU Board pins. Check for proper ground.
PRESS START or ACTION BUTTON AND NOTHING HAPPENS	Check for open wires between button and CPU Board. Check for contamination on CPU Board pins or button switch blade contacts. Check for proper ground.
NO CREDIT GIVEN WHEN COINS ARE INSERTED	Check DIP switch coin setting. Check for contamination on coin switch contacts. Check for an open wire between Coin Switch 1 and pin 16 on JAMMA Connector or Coin Switch 2 and pin T of JAMMA Connector.
TOO MANY CREDITS FOR NUMBER OF COINS INSERTED	Check Game Pricing setting. Check for a short between pins T & 16 on JAMMA Connector.
GAME STAYS IN THE TEST MODE.	Check that the Test Switch (if you have installed one) and the Test Switch (Position 8) on DIP Switch 2 are set to OFF.

NOTES:

HIGH IMPACT FOOTBALL KIT

**S E C T I O N
TWO**



PARTS INFORMATION

REV	DESCRIPTION OF CHANGE	ECN NO DATE
	NDR	8-27-90 24725
A	ADDED 24 PIN RAM INFO. ALSO SEE SHEET 2.	9-6-90 24887 9-17-90

AUDIO BOARD ASSEMBLY A-13971-40004

Item Part Number Designation Description

1	20-9229		Thermal Compound
2	4006-01113-06		#6-32 x 3/8 P-PH-S
3	4406-01128-00		#6-32 Hex Nut
4			---
5	5010-08772-00	R18	RES. 15K 1/4 W 5%
6	5010-08824-00	R32	RES. 43K 1/4 W 5%
7	5010-08846-00	R31	RES. 220K 1/4 W 5%
8	5010-08983-00	R7, R8, R9	RES. 3.3K 1/4 W 5%
9	5010-08991-00	R1, R4, R5, R11, R12, R25 - R28, R33, R36, R37, R49, R50	RES. 4.7K 1/4 W 5%
10	5010-08998-00	R2, R3	RES. 2.2K 1/4 W 5%
11	5010-09034-00	R17, R22 - R24, R34	RES. 10K 1/4 W 5%
12			
13	5010-09161-00	R35, R45	RES. 2.2 Ω 1/4 W 5%
14	5010-09162-00	R39	RES. 100K 1/4 W 5%
15	5010-09179-00	R10	RES. 3.3M 1/4 W 5%
16	5010-09181-00	R44, R48	RES. 1 Ω 1/2 W 5%
17	5010-09219-00	R38	RES. 8.2K 1/4 W 5%
18	5010-09324-00	R6, R19, R20, R21	RES. 27K 1/4 W 5%
19	5010-09331-00	R16	RES. 13K 1/4 W 5%
20	5010-09333-00	R29	RES. 180K 1/4 W 5%
21	5010-09342-00	R30	RES. 36K 1/4 W 5%
22	5010-09358-00	R41, R42	RES. 1K 1/4 W 5%
23	5010-09361-00	R43, R46, R47	RES. 220 Ω 1/2 W 5%
24	5010-10258-00	R40	RES. 1M 1/4 W 5%
25	5010-10985-00	R14, R15	RES. 20K 1/4 W 5%
26	5013-09427-00	R13	RES. 4.99K 1/4 W 5%
27	5040-09343-00	C1, C3, C4, C8, C17	CAP. 10M 20V +/- 20%
28	5040-09365-00	C11	CAP. 1M 63V +/- 50% -10%
29	5040-09776-00	C26, C30	CAP. 470M 16V +/- 50% -10%
30	5040-10974-00	C12, C19, C24	CAP. 100M 35V
31	5040-12006-00	C29, C32	CAP. 1000M 16V 20% RD.
32	5041-09243-00	C25, C28	CAP. 10M 10V +/- 10%
33	5043-08980-00	C5, B(17)	CAP. .01M 50V +/- 80% -20%
34	5043-08996-00	C31, C33	CAP. 1M 50V +/- 20%
35	5043-09065-00	C13, C14, C15	CAP. 470P 50V +/- 20%
36	5043-09492-00	C2, C34	CAP. 100P 50V +/- 20%
37	5043-09844-00	C6	CAP. 47P 50V +/- 20% AX
38	5043-09845-00	C16, C18, C20 - C23, C27	CAP. 1KP 50V +/- 20% AX
39	5046-09346-00	C7	CAP. 1200P 50V +/- 5%
40	5046-09350-00	C9	CAP. 180P 100V +/- 5%
41	5048-10992-00	C10	CAP. 4700P 50V +/- 10%
42	5060-10396-00	SP1	SIP 4.7K 470P 8RBC
43	5160-10269-00	Q1	TRANS 2N3904 NPN
44	5281-09215-00	U2	IC 74LS04 HEX INV
45	5281-09235-00	U21	IC 74LS10 TRPL NAN
46	5281-09246-00	U14	IC 74LS139 2-4 DEC
47	5281-09487-00	U7, U16	IC 74LS74 DUAL D F/F
48	5281-09745-00	U15	IC 74LS138 DMLTPX
49	5281-10043-00	U13	IC 74LS175
50	5340-10139-00	U5	RAM/S 5518-2 21KX8
51	5370-09156-00	U22, U23	IC 2002 AUD AMP
52	5370-09321-00	U9, U10, U17, U18	IC 1458 OP - AMP
53	5370-09691-00	U6	IC 55536-9 CVSD
54	5371-09152-00	U11	IC 1408 D/A CONV
55	5430-10322-00	U12	IC 68B21 PIA 2MHz
56	5520-09020-00	X1	Crystal 3.58MHz
57	5521-10931-00	CR1	OSC 8 MHz
58	5551-09822-00	L1, L2, L3	IND 4.7 UH 3A
59	5700-08985-00	U8	Socket IC 40 Pin
60	5700-09004-00	U3	Socket IC 24 Pin
61	5700-09006-00	U1	Socket IC 16 Pin
62	5700-12088-00	U4, U19, U20	Socket IC 32 Pin
63	5705-09199-00		Heat Sink #6030B
64	5766-12702-00		PCB Audio System
65	5791-09437-00	J4	20 HCN 2x10 ST
66	5791-10862-04	J1, J2, J5	4H STR SQ. Pin .156
67	5791-10862-06	J3	6H STR SQ. Pin .156

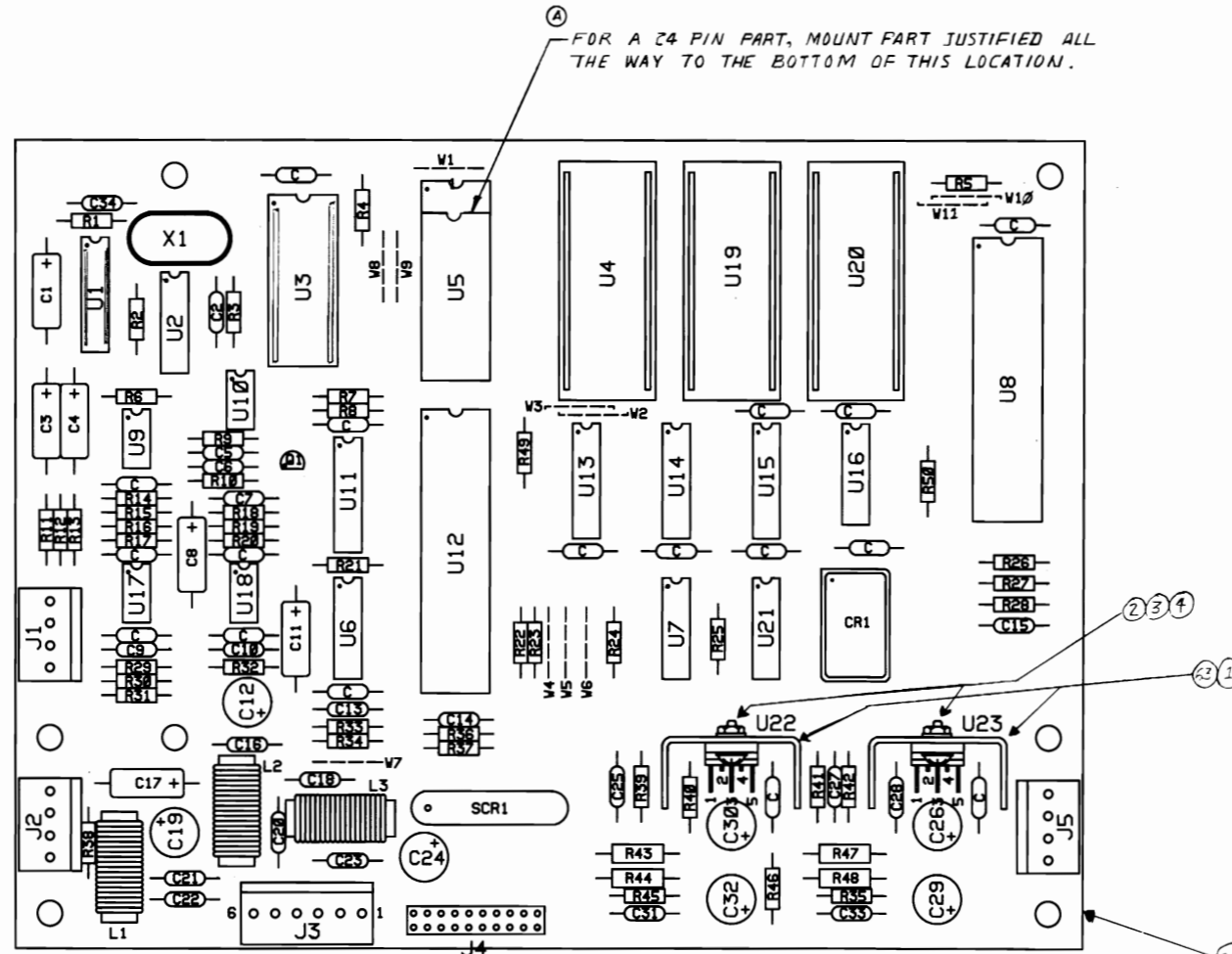

2-5

ITEM	PART NUMBER	DESCRIPTION	QTY	ITEM	PART NUMBER	DESCRIPTION	QTY
THE INFORMATION CONTAINED ON THIS DRAWING IS CONFIDENTIAL PROPERTY OF THE COMPANY. IT MAY NOT BE USED OR DISCLOSED TO OTHERS WITHOUT WRITTEN PERMISSION.							
PROJ ENGR C. BLEICH	DO NOT SCALE! WORK TO DIMENSIONS SHOWN		REMOVE BURRS-BREAK SHARP CORNERS & EDGES TOLERANCES UNLESS OTHERWISE SPECIFIED DECIMAL ±.030 ANGULAR ±1/2° .XX ±.015 XXX ±.005 FRACTIONAL ±1/64		WILLIAMS MIDWAY ELECTRONICS GAMES, INC. MANUFACTURING COMPANY 3401 N. CALIFORNIA AVE CHICAGO, IL 60618		
DWN BY J. JACOBS	DATE 6/1/91	FIRST PROJECT NO. 40004	MATERIAL		NAME AUDIO SOUND CHIP SUB-ASSY		
CHECKED BY S.M.M.	DATE 8/24/91	FIRST USAGE A-13971	QTY 1		SCALE /	SHT 1 OF 2	REV A

3970-

Y-UNIT CPU BOARD

Y-UNIT CPU ASSEMBLY p/n C-13234-40004

Part No.	Ckt. Designator	Description	Part No.	Ckt. Designator	Description
5770-12555-00		Bare PC Brd.	5019-09362-00	SR3, SR4, SR6	SIP, 4.7K Ω
5281-09737-00	U1	IC, 74LS 86		SR7, SR11, SR15	
5317-12211-00	U2, U20, U24, U43	IC, 74ALS541		SR17, SR19-SR24	
5317-12212-00	U61, U62, U70	IC, 74ALS574	5019-10143-00	SR5	SIP, 47K Ω 9 Res.
	U3, U6, U7, U21, U25		5060-10396-00	SRC4, SRC5	SIP. 4.7K Ω 470pf
	U50, U58, U63, U64			SRC10, SRC14	
	U71, U72, U74, U79, U84, U85			SRC16	
5317-12208-00	U4, U22, U54-U57	74ALS245		LED1, LED 2	LED, Red
	U59, U60, U75-U78		5671-09019-00	L1	Inductor, 4.7UH
	U80, U81, U94, U110		5551-09822-00	DS1, DS2	DIP. Sw. 16 pin
5340-12242-00	U5, U23	IC, 8K x 8 S RAM	5645-09025-00	SW1	Pushbutton Sw.
5700-12047-00	U8, U52, U53, U65	24 pin Socket	5641-12551-00	B1	Battery Holder
5340-12213-00	U10, U11, U28-U33	IC, 4461 VRAM	5881-12315-00	J2	8 pin Connector
5521-10421-00	U16	40 MHZ Xtal	5791-10862-00	J4	12 pin Connector
5521-10318-00	U17	24 MHZ Xtal	5791-12461-00	J6, J7	26 pin Ribbon Connector
5283-10468-00	U19, U45	IC, 74F74	5791-10850-00	J8	20 pin Ribbon Connector
			5791-12461-10	J12	10 pin Connector
5019-10849-00	U27, U34, U44, U48	100 Ω DIP Res.	5791-12461-05	J13	5 pin Connector
5317-12305-00	U35	IC, 74ALS00	5700-12252-00	U12-U15	24pin Connector
5700-12253-00	U36	68 pin Socket			
5280-09309-00	U37	IC, 7407			
5281-09487-00	U38	IC, 74LS74			
5434-12255-00	U39	IC, MAX691			
5700-09915-00	U40-U42	20 pin Socket			
5311-12287-00	U47, U46, U87, U100	IC, 74HC541			
	U101, U103, U104				
5700-10176-00	U49	28 pin Socket			
5311-12285-00	U51, U73, U82	IC, 74HC573			
5340-12014-00	U66-U69	IC, 4464 DRAM			
5283-10552-00	U83	IC, 74F04			
5370-12602-00	U86	IC, ULN2064B			
5317-12023-00	U88	IC, 74ALS138			
5700-12088-00	U89-U93, U95-U98	32 pin Socket			
	U105-U109, U111-U114				
5700-12254-00	U99	144 pin Socket	A-5343-40004-1	U89	IC, Game EPROM
5317-12024-00	U102	IC, 74ALS139	A-5343-40004-10	U105	IC, Game EPROM
5700-08985-00	U115	40 pin Socket	A-5343-40004-11	U106	IC, Game EPROM
5010-08991-00	R1, R24, R27	Res. 4.7K Ω 5% 1/4W	A-5343-40004-12	U107	IC, Game EPROM
5010-10204-00	R2, R7, R12	Res. 1K Ω 2% 1/4W	A-5343-40004-13	U108	IC, Game EPROM
5010-10205-00	R3, R8, R13	Res. 2K Ω 2% 1/4W	A-5343-40004-14	U109	IC, Game EPROM
5010-10000-00	R4, R9, R14	Res. 3.9K Ω 5% 1/4W	A-5343-40004-15	U111	IC, Game EPROM
5010-09219-00	R5, R10, R15	Res. 8.2K Ω 5% 1/4W	A-5343-40004-16	U112	IC, Game EPROM
5010-08772-00	R6, R11, R16	Res. 15K Ω 5% 1/4W	A-5343-40004-17	U113	IC, Game EPROM
5010-09001-00	R23, R25	Res. 330 Ω 5% 1/4W	A-5343-40004-18	U114	IC, Game EPROM
5010-09036-00	R50, R51	Res. 100 Ω 5% 1/4W	A-5343-40004-2	U90	IC, Game EPROM
5010-09416-00	R35-R37, R46-R48	Res. 470 Ω 5% 1/4W	A-5343-40004-3	U91	IC, Game EPROM
5010-08997-00	R38-R45	Res. 2.7 Ω 5% 1/4W	A-5343-40004-4	U92	IC, Game EPROM
5010-09534-00	W2, W8, W11, W12, W14, W21, W22, W24, W27, W29, W31, W32, W34, W36, W39, W41, W45, W47, W48, W50, W42, W52, W55, W57, W60, W62, W66, W68, W58, W69, W71, W73, W75, W77, W80	Res. 0 Ω	A-5343-40004-5	U93	IC, Game EPROM
			A-5343-40004-6	U95	IC, Game EPROM
			A-5343-40004-7	U96	IC, Game EPROM
			A-5343-40004-8	U97	IC, Game EPROM
			A-5343-40004-9	U98	IC, Game EPROM
			A-5346-40004-1	U8	IC, PLD Color RAM Control
			A-5346-40004-2	U40	IC, PLD Address Decode
			A-5346-40004-3	U41	IC, PLD Video RAM Control
			A-5346-40004-4	U42	IC, PLD Local Control
			A-5346-40004-5	U52	IC, PLD Video RAM Sequencer
			A-5346-40004-6	U53	IC, PLD Image ROM Control
			A-5346-40004-7	U65	IC, PLD Miscellaneous Control
			A-5346-40004-8	U115	IC, PLD Autoerase Controller
5043-08980-00	B	Cap. .01 μ fd 10V	5340-12558-00	U49	IC, 8K x 8 Static RAM 150ns Low Power
5040-08986-00	C1, C2, C5, C10	Cap. 100 μ fd 10V	5400-12220-00	U36	IC, TMS34010-50 GSP
5043-09845-00	C3, C4	Cap. .001 μ fd 10V	5410-12239-00	U99	IC, Custom Asic
5041-09243-00	C6-C9	Cap. 10 μ fd 10V	5880-11056-00	B1	Battery, Lithium 3V
5043-08996-00	C11	Cap. .1 μ fd	5340-12213-00	U12-U15	IC, 4461 VRAM, 64 x 4 150ns
5019-12611-00	SR1, SR2, SR8	SIP, 47K Ω 5 Res.	03-8338-1		Spacer, 1/4"
	SR9, SR12, SR13, SR18				

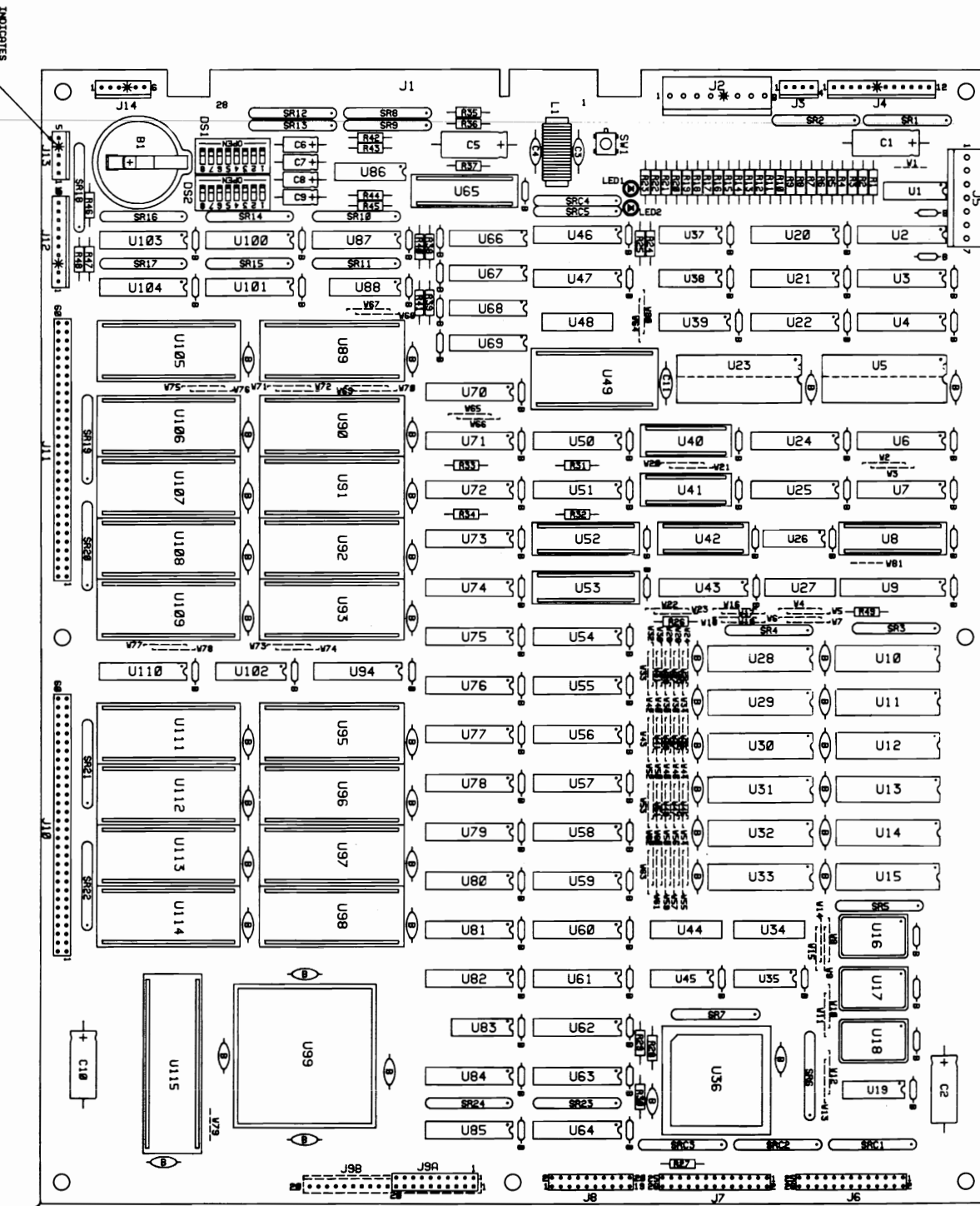

HIGH IMPACT FOOTBALL KIT

S E C T I O N THREE



DIAGRAMS & SCHEMATICS

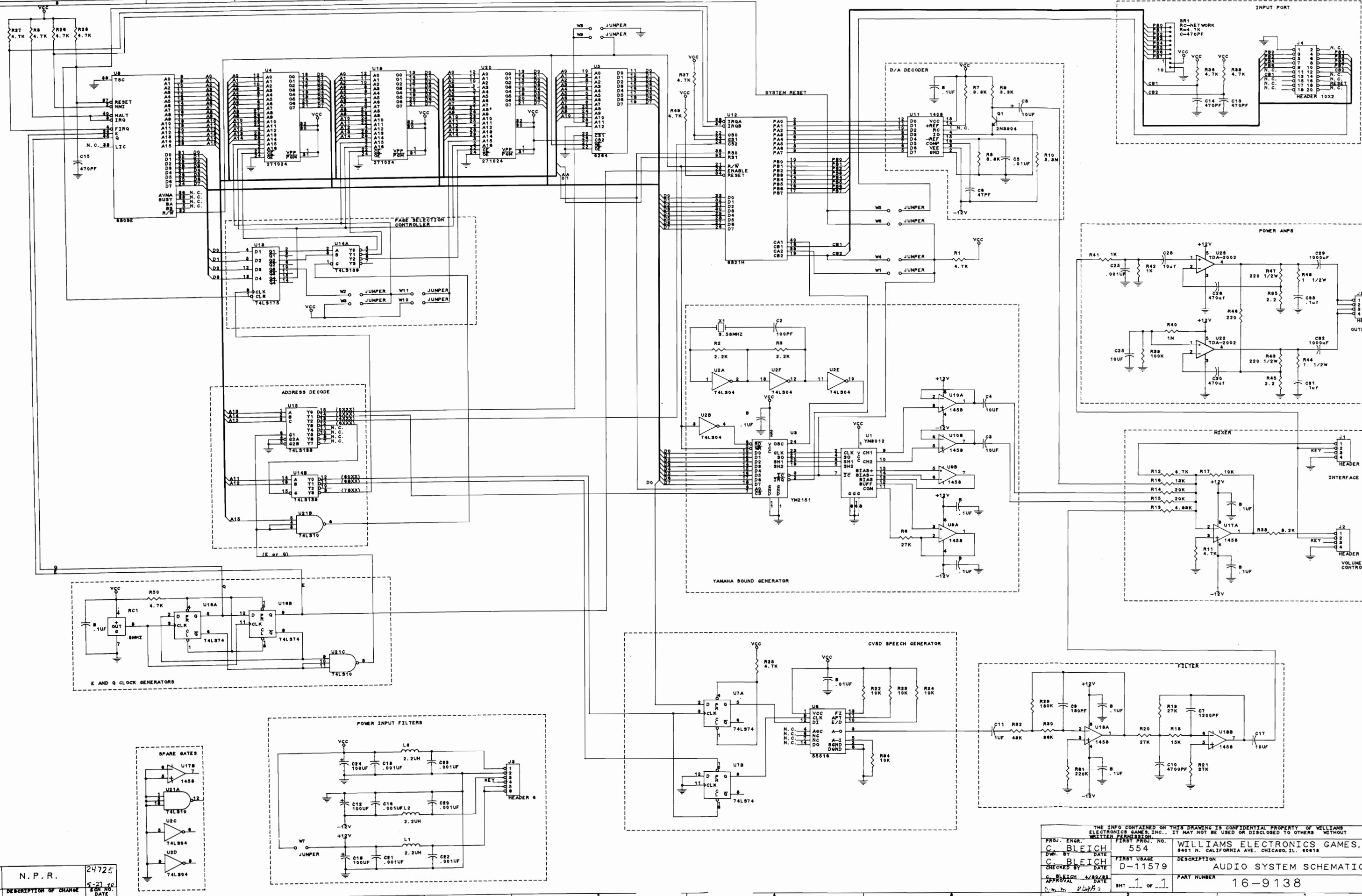

N. P. R. 24725
 REV DESCRIPTION OF CHANGE 5-27-76
 KEY NO. DATE

THE INFO CONTAINED ON THIS DRAWING IS CONFIDENTIAL PROPERTY OF WILLIAMS ELECTRONICS GAMES, INC. IT MAY NOT BE USED OR DISCLOSED TO OTHERS WITHOUT WRITTEN PERMISSION.		WILLIAMS ELECTRONICS GAMES, INC. 3401 N. CALIFORNIA AVE. CHICAGO, IL. 60618	
PROJ. ENGR. C. BLEICH	FIRST PROJ. NO. 554	DATE	DESCRIPTION
CHECKED BY C. BLEICH	DATE D-11579	DATE	AUDIO SYSTEM SCHEMATIC
APPROVAL C. BLEICH	DATE 4/30/84	PART NUMBER	16-9138
SHT 1 of 1		REV	

CPU Schematic Sheet 1 of 16

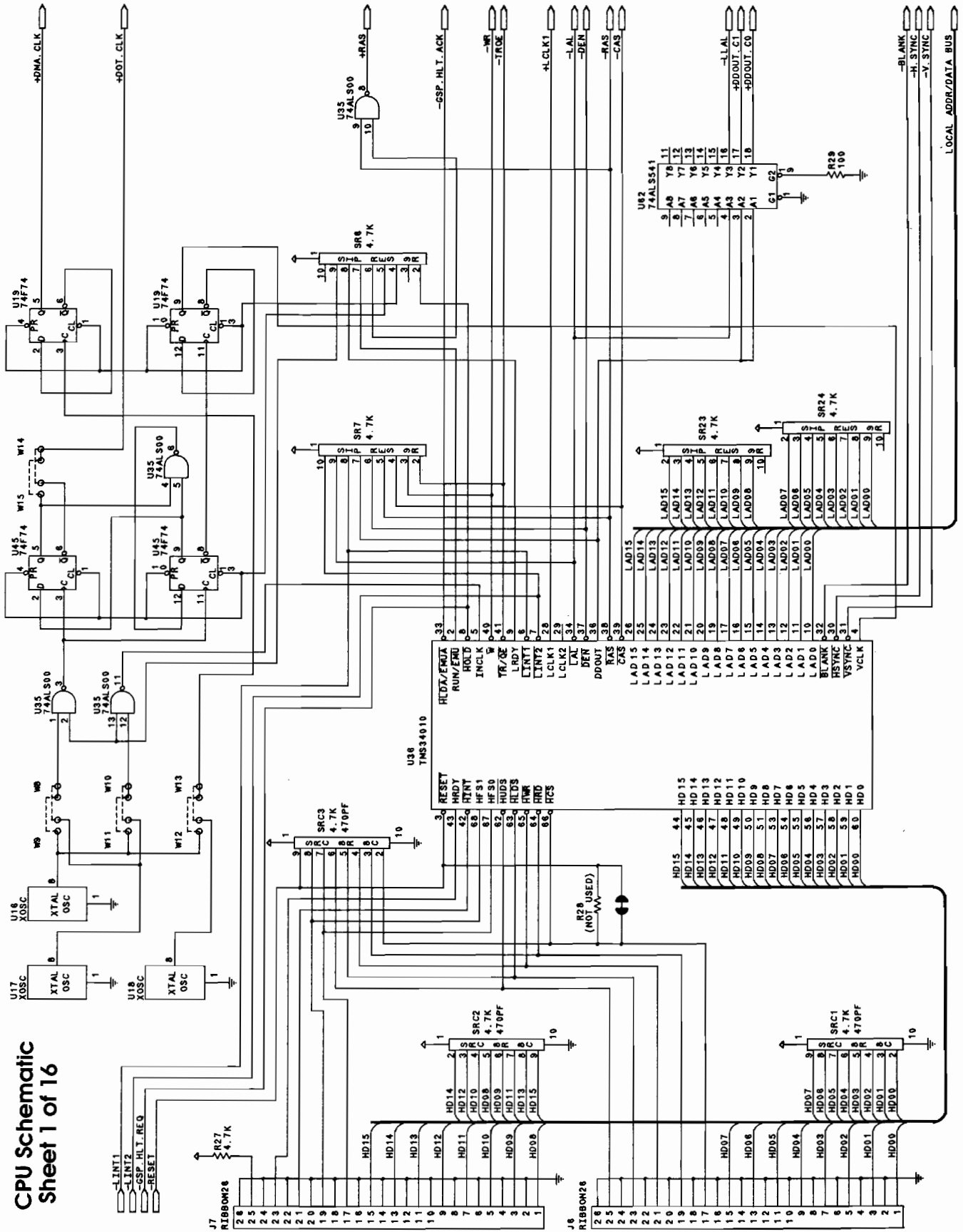

LOCAL_ADDR_BUS -X*

CPU Schematic Sheet 2 of 16

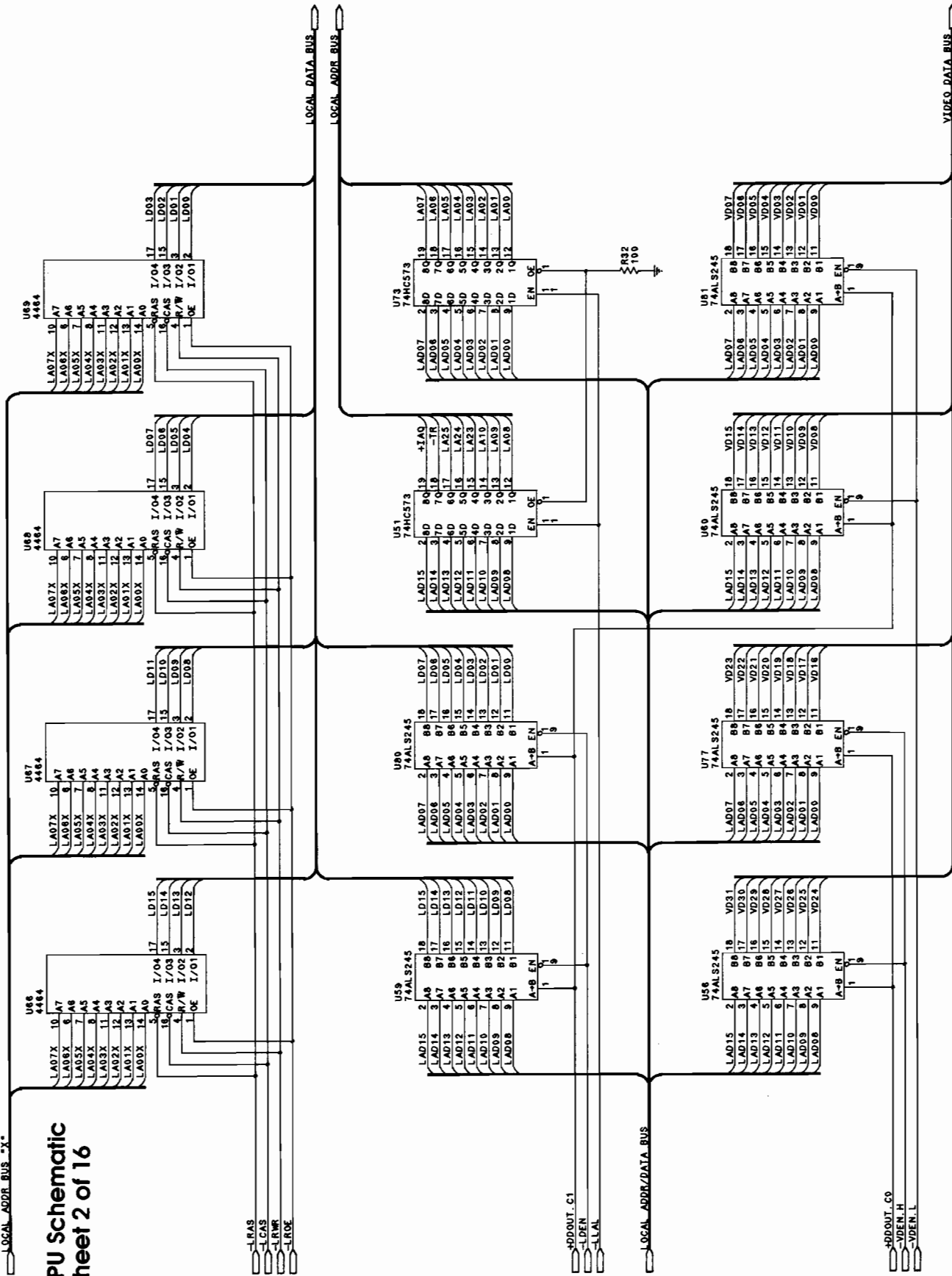

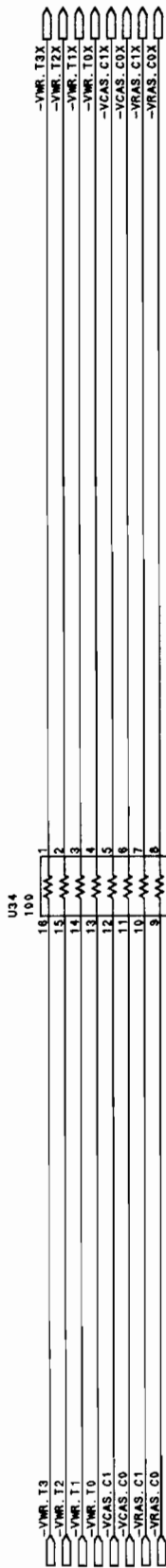

CPU Schematic Sheet 4 of 16

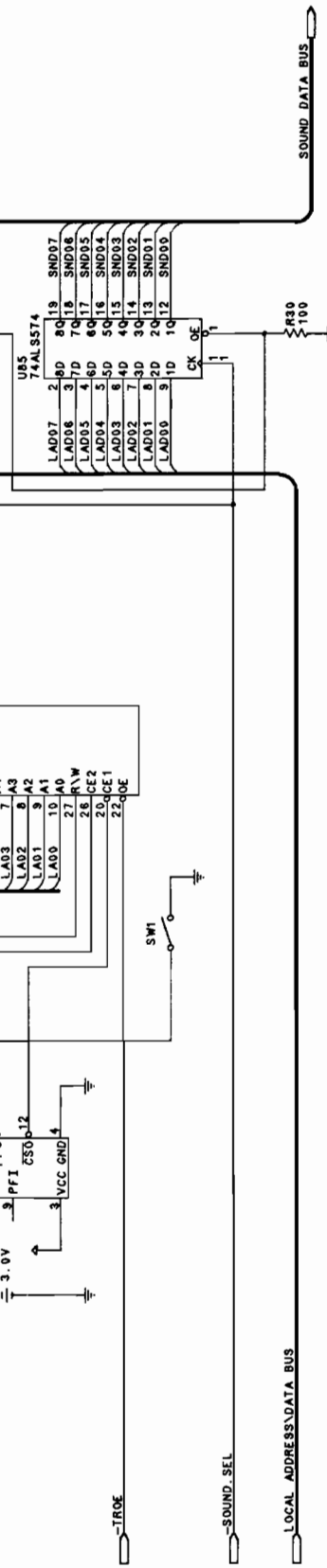
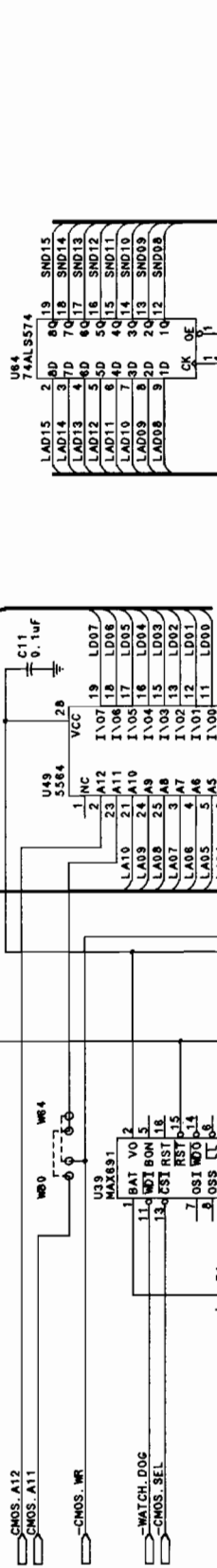
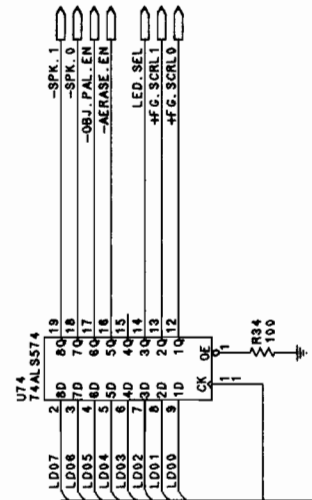

CPU Schematic Sheet 5 of 16

PROGRAM MEMORY

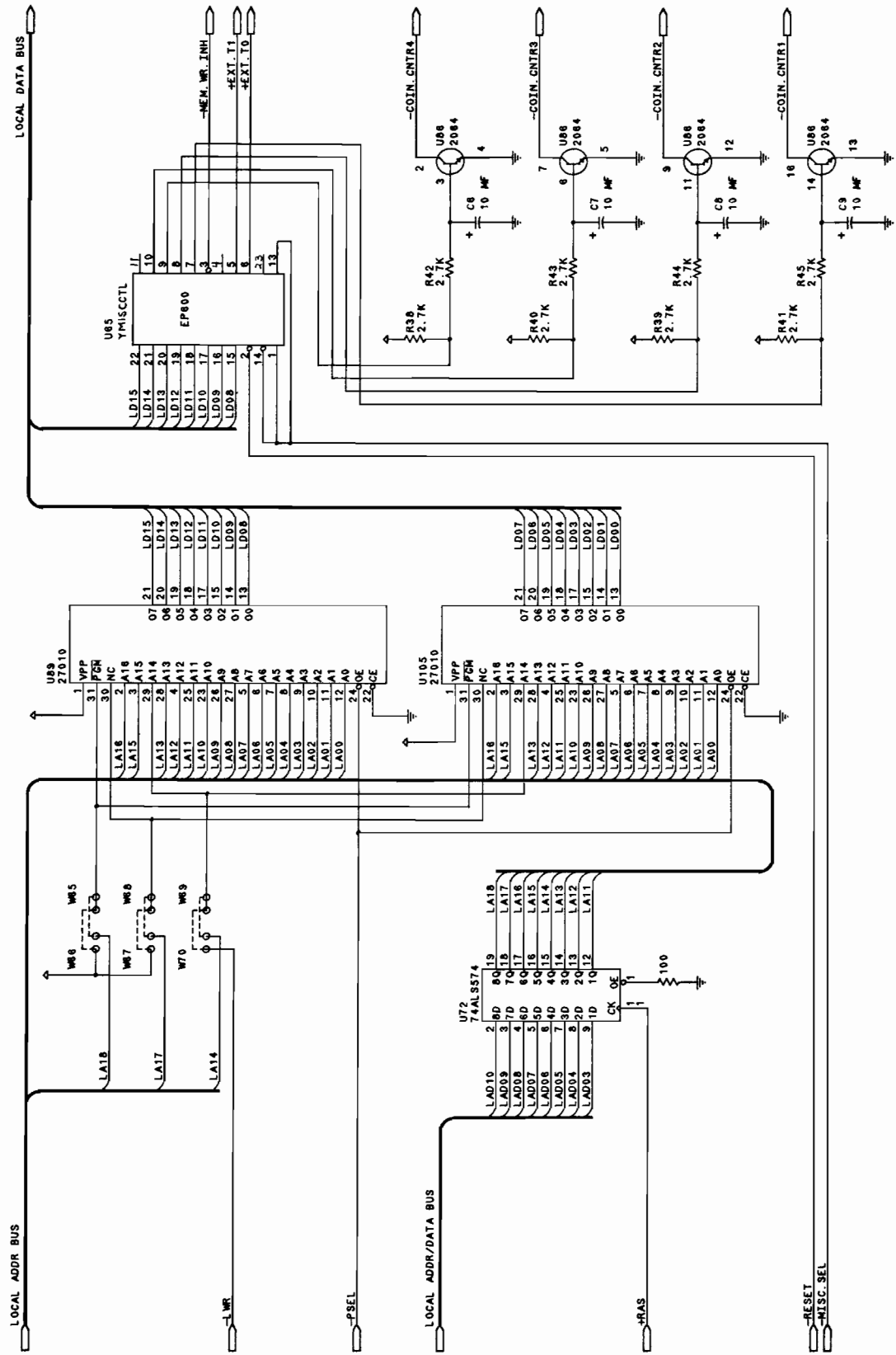

LOCAL_ADDR/DATA BUS

CPU Schematic Sheet 6 of 16

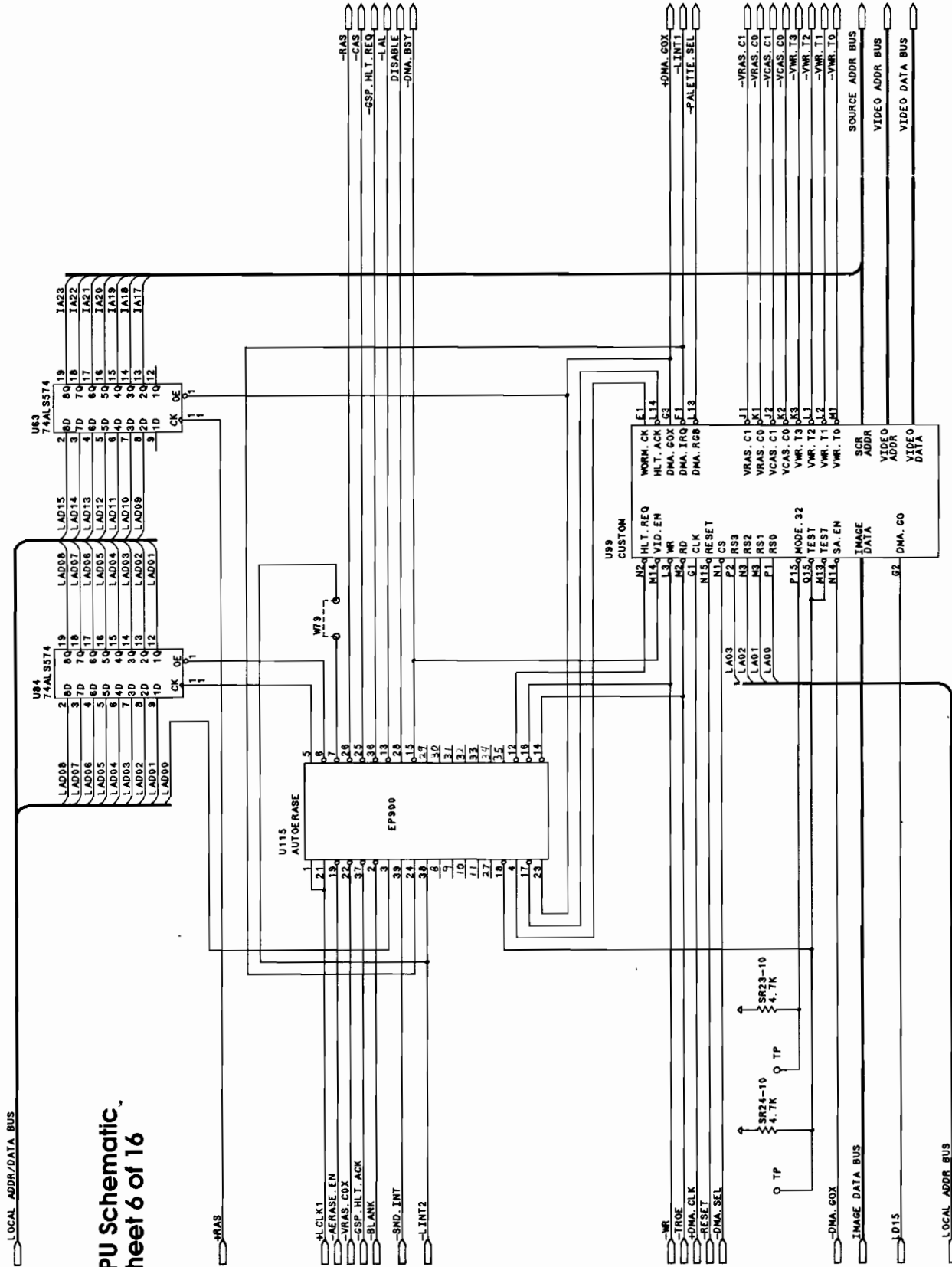

LOCAL DATA BUS

CPU Schematic Sheet 7 of 16

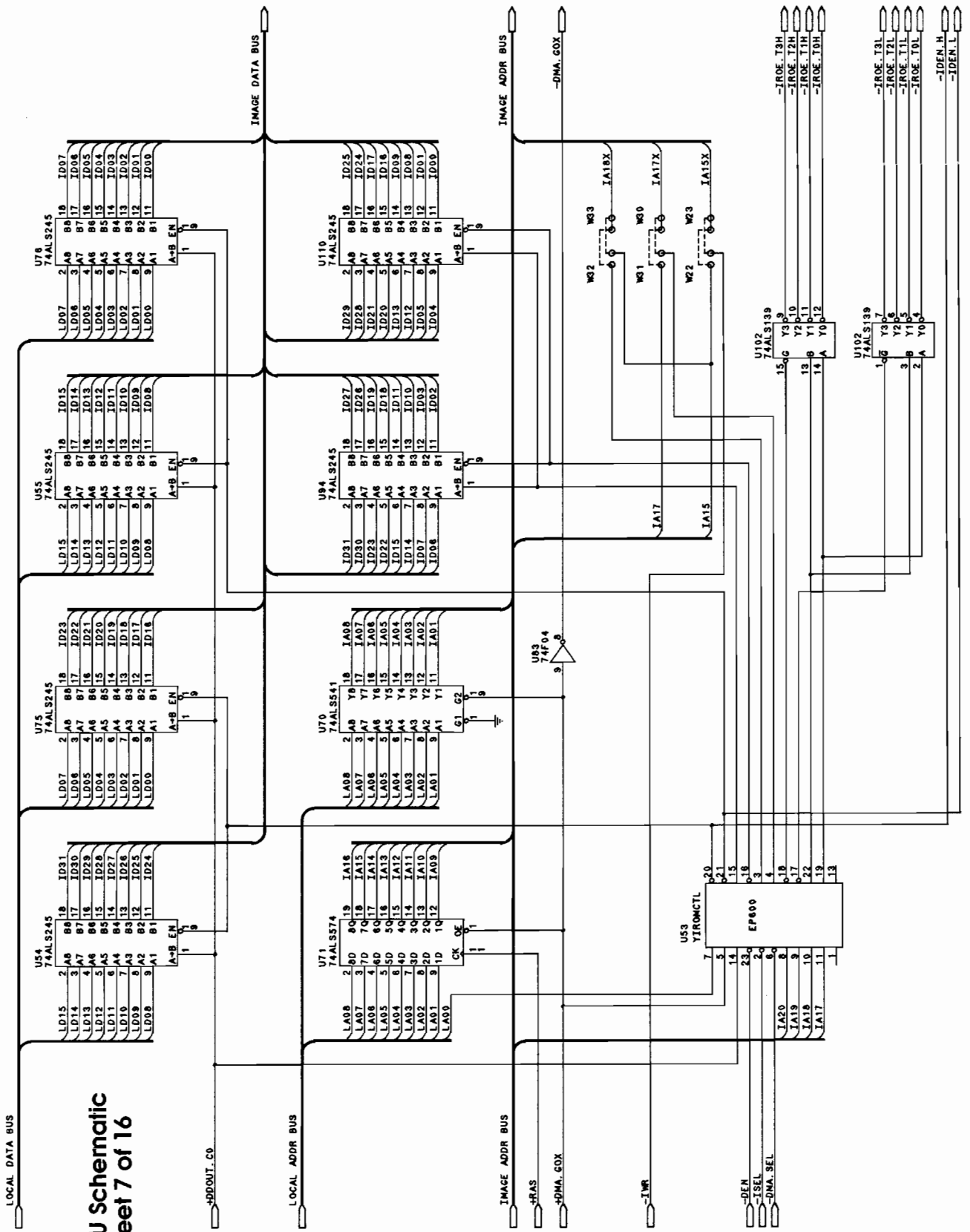

CPU Schematic Sheet 8 of 16

IMAGE MEMORY

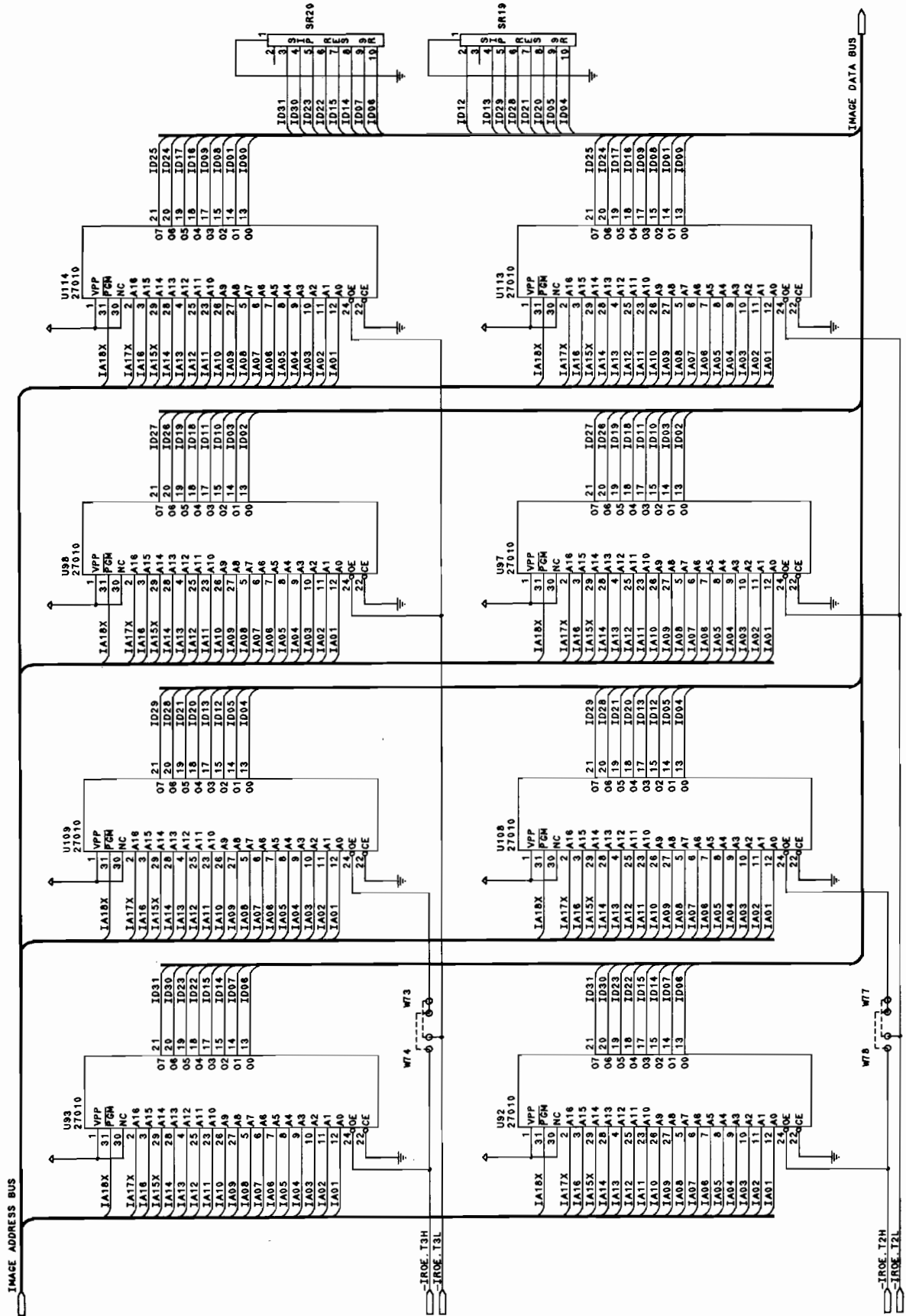

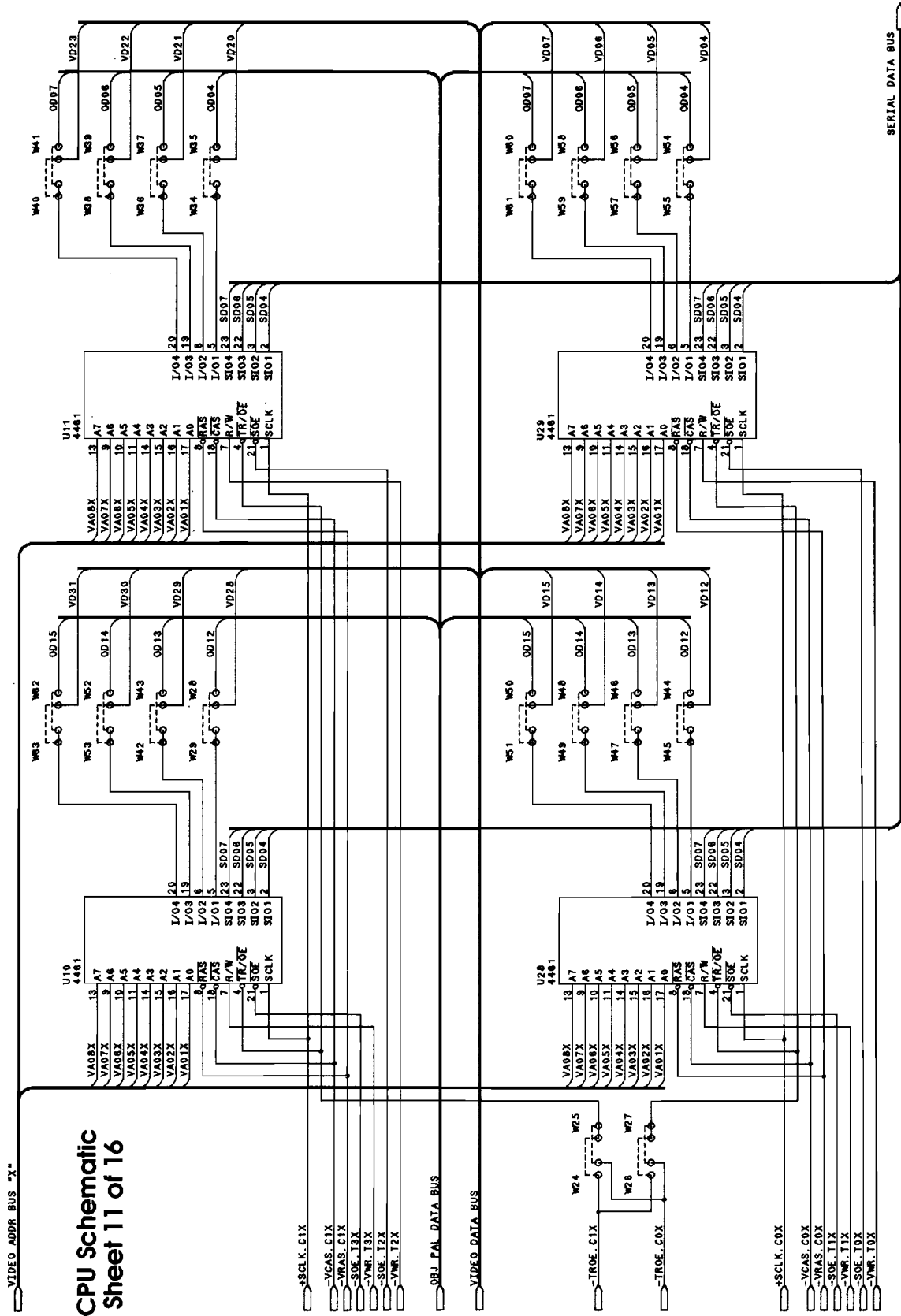

**CPU Schematic
Sheet 11 of 16**

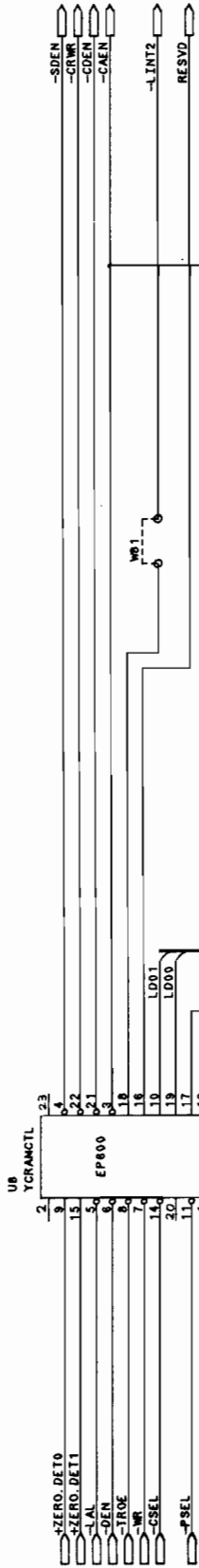

**CPU Schematic
Sheet 12 of 16**

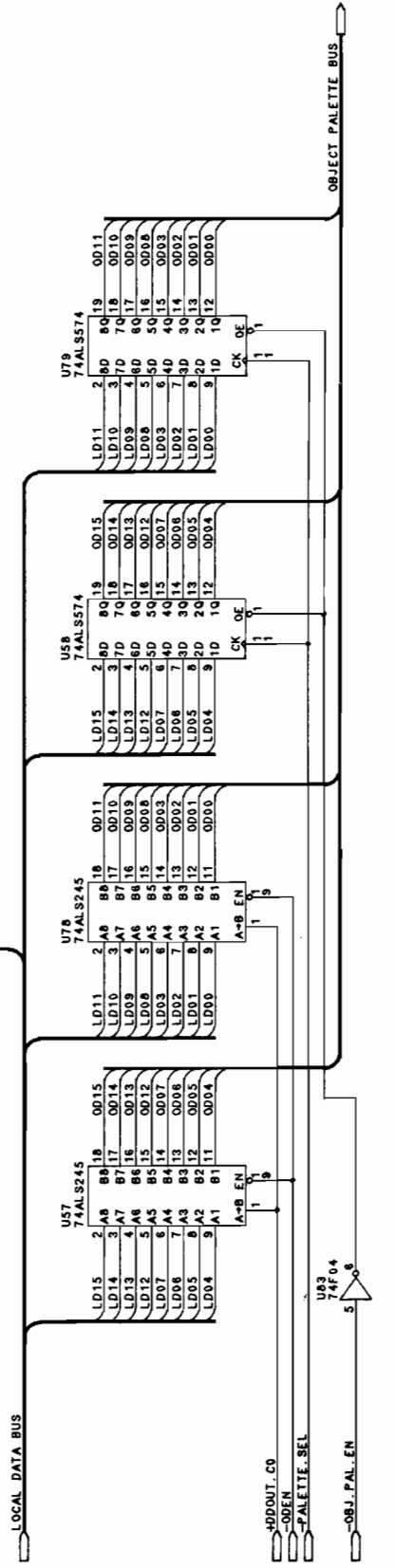
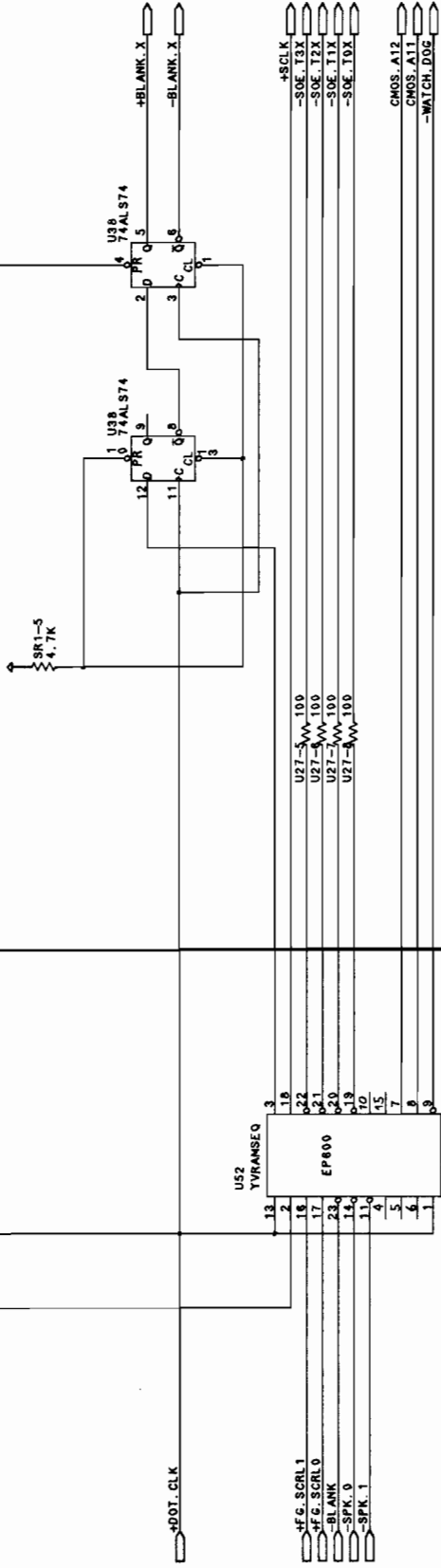

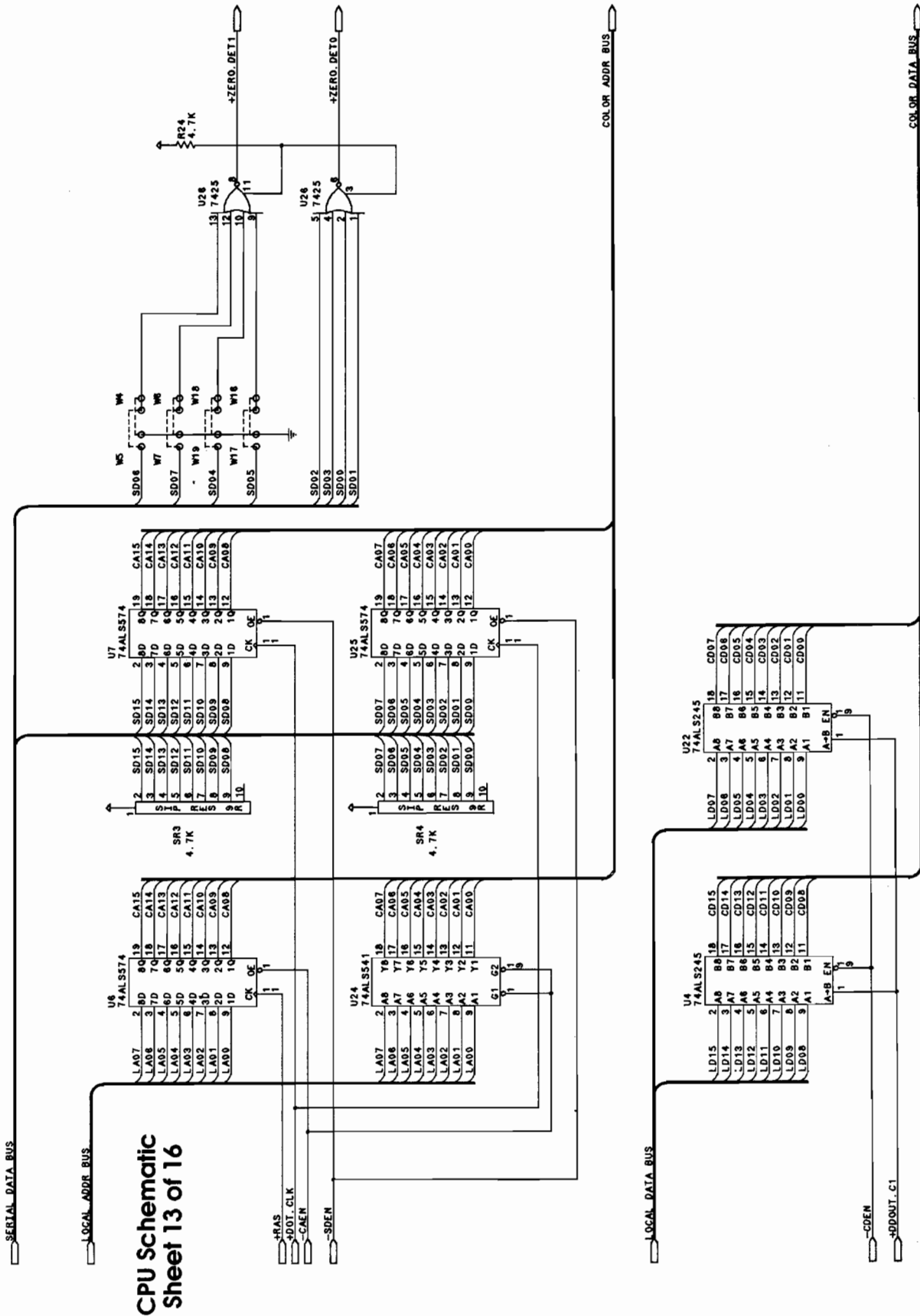

CPU Schematic Sheet 14 of 16

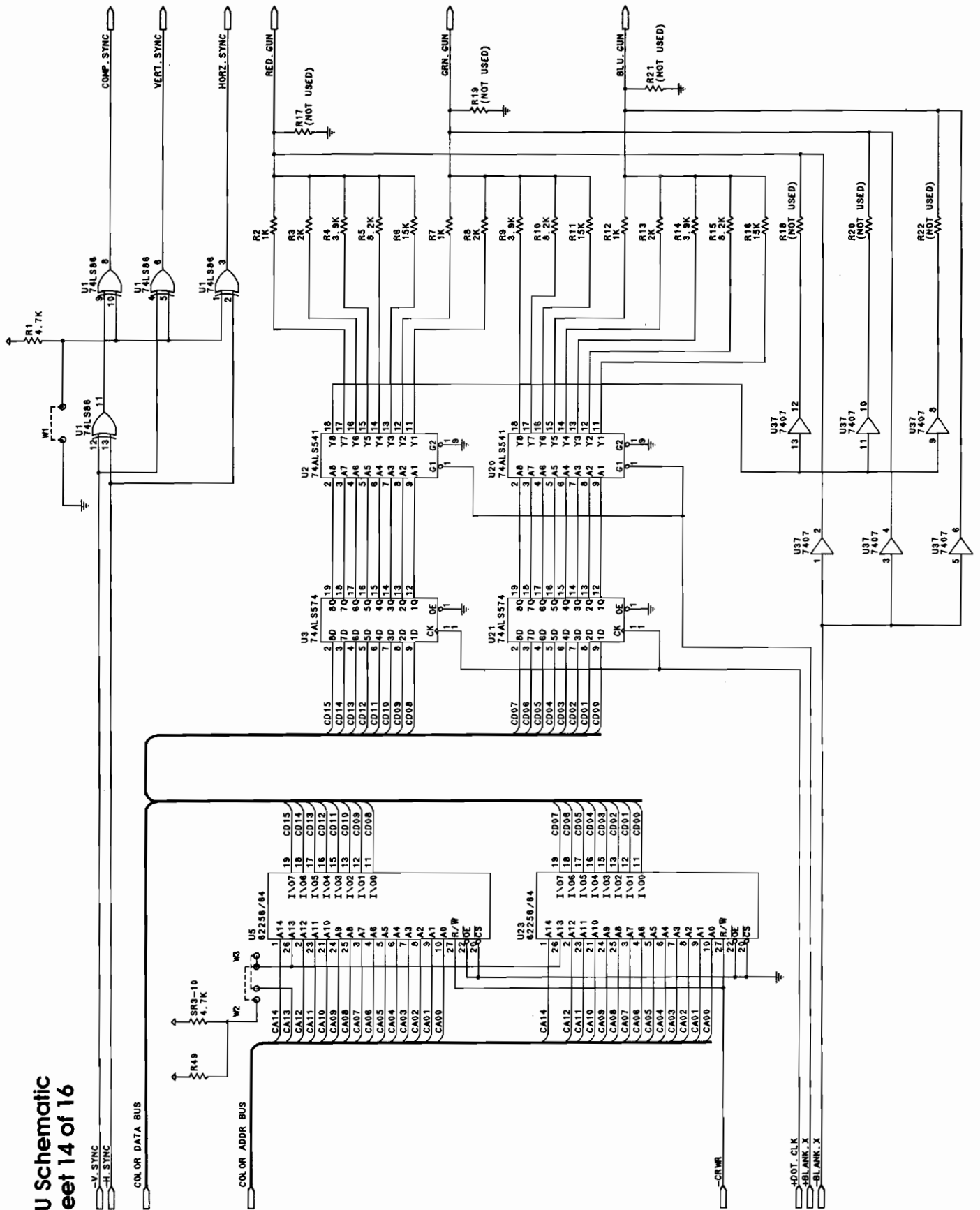

CPU Schematic Sheet 16 of 16

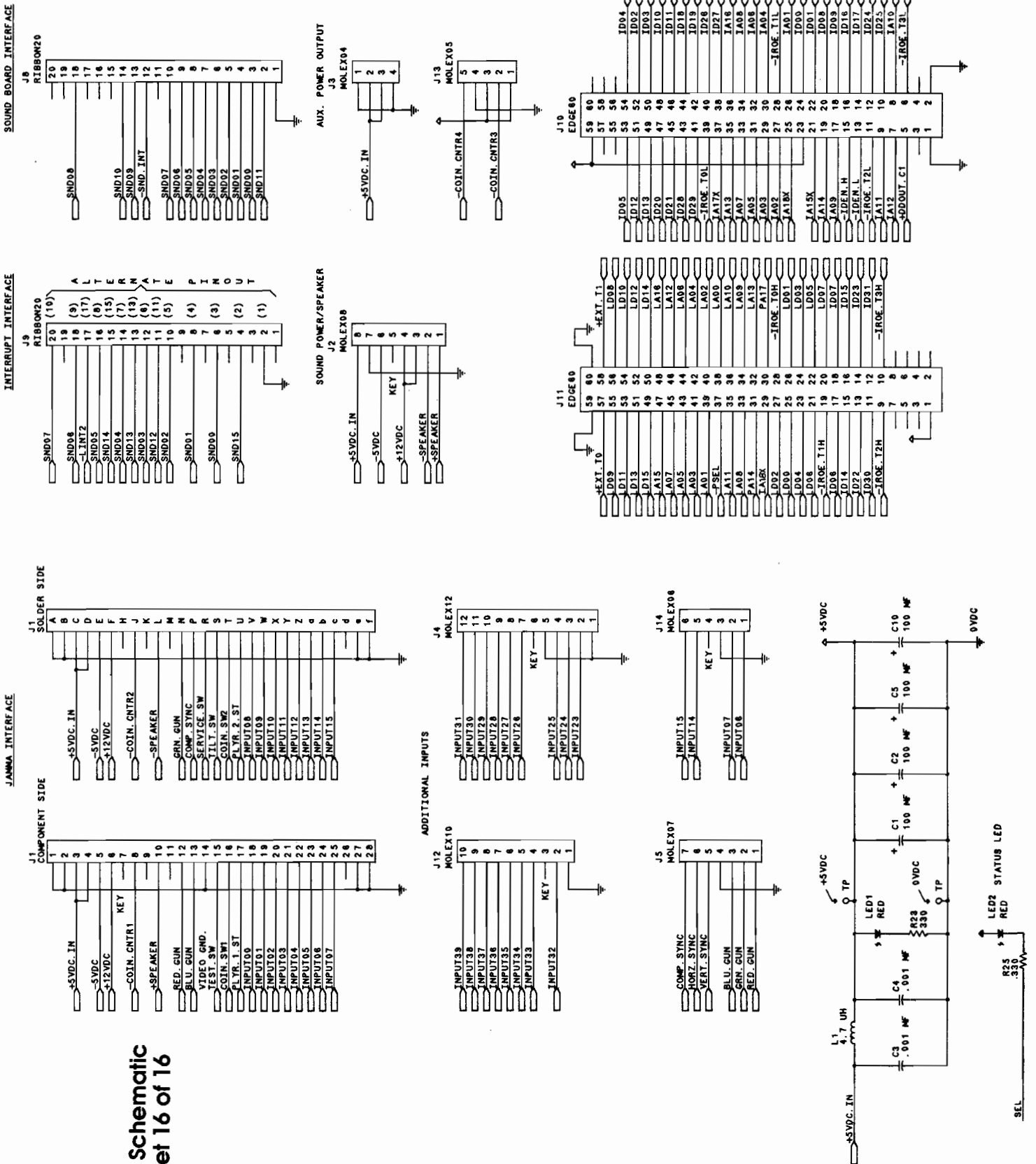

HIGH IMPACT FOOTBALL KIT JAMMA Chart

FUNCTION	WIRE COLOR	PIN	PIN	WIRE COLOR	FUNCTION
Ground	Blk	1	A	Blk	Ground
Ground	Blk	2	B	Blk	Ground
+5 Volts DC	Gry	3	C	Gry	+5 Volts DC
+5 Volts DC	Gry	4	D	Gry	+5 Volts DC
-5 Volts DC	Gry-Grn	5	E	Gry-Grn	-5 Volts DC
+12 Volts DC	Gry-Yel	6	F	Gry-Yel	+12 Volts DC
	Key	7	H	Key	
Counter 1 *	Wht-Orn	8	J	Wht-Grn	Counter 2 *
	NC	9	K	NC	
Speaker (+)	Red-Vio	10	L	Grn-Vio	Speaker (-)
	NC	11	M	NC	
Video Red	Red	12	N	Grn	Video Grn
Video Blue	Brn	13	P	Wht	Video Sync
Video Grd	Shield	14	R	Wht-Red	Service Credit *
Test *	Grn	15	S	Wht-Vio	Slam Tilt *
1 Coin	Wht-Blu	16	T	Yel-Wht	2 Coin
1 Start	Yel-Grn	17	U	Yel-Blu	2 Start
1 Up	Org-Blk	18	V	Yel-Blk	2 Up
1 Down	Org-Brn	19	W	Yel-Brn	2 Down
1 Left	Org-Red	20	X	Yel-Red	2 Left
1 Right	Org	21	Y	Yel-Org	2 Right
1 Action	Org-Yel	22	Z	Yel-Vio	2 Action
NC	Org-Grn	23	a	Yel-Gry	NC
NC	Org-Blu	24	b	Vio-Blk	NC
NC	Org-Vio	25	c	Vio-Brn	NC
NC	Org-Gry	26	d	Vio-Red	NC
Ground	NC	27	e	Blk	Ground
Ground	Blk	28	f	Blk	Ground

* Optional function- Game will operate without these.

HIGH IMPACT FOOTBALL KIT CABINET WIRING

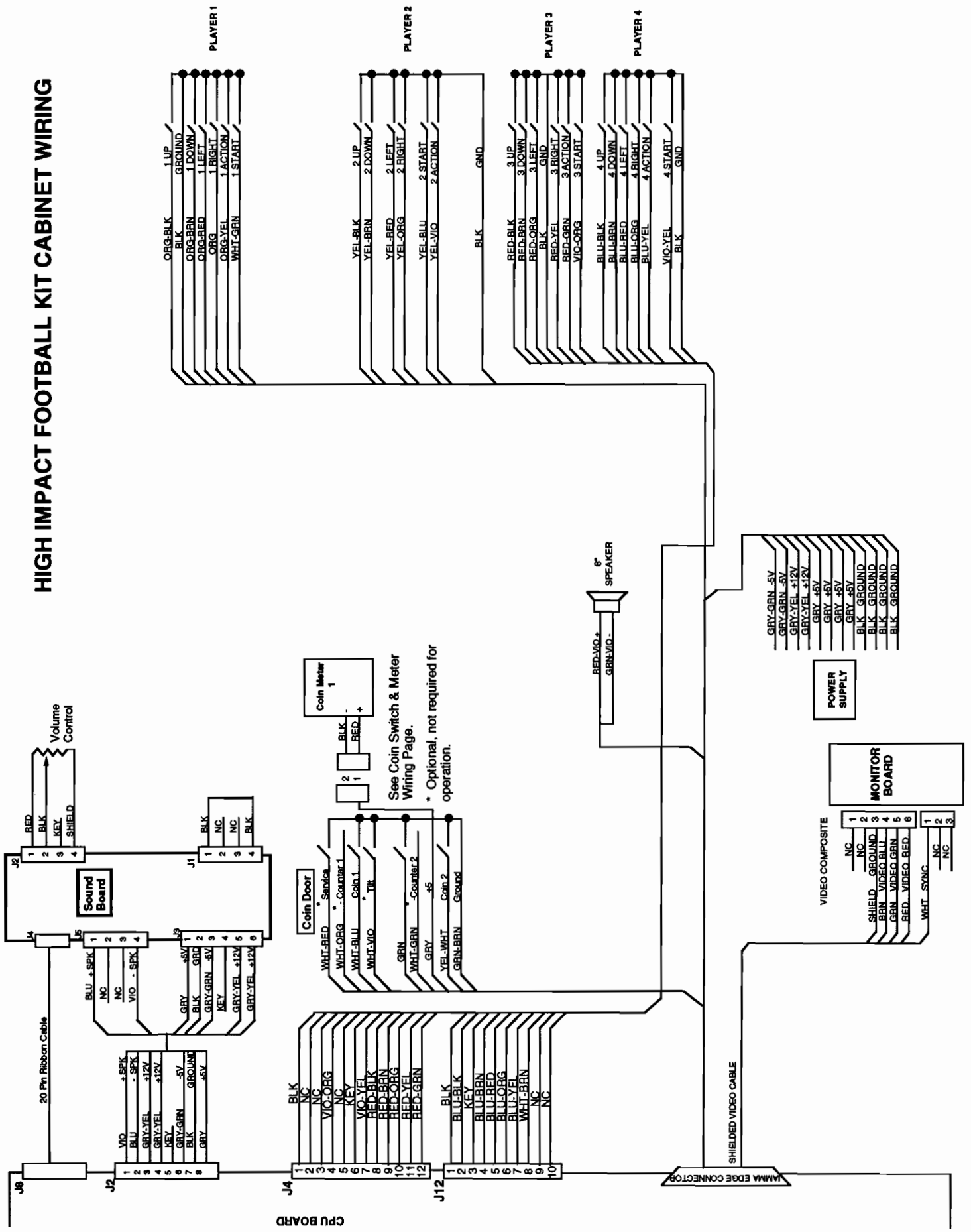

HIGH IMPACT FOOTBALL KIT INTERBOARD WIRING

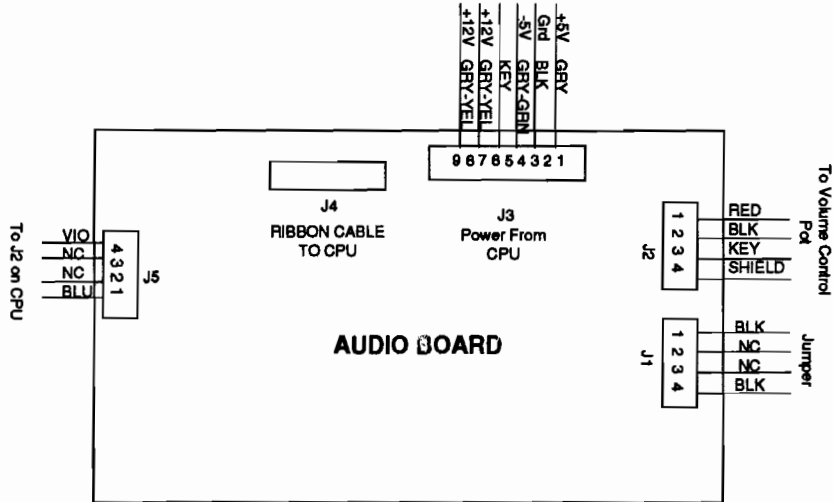
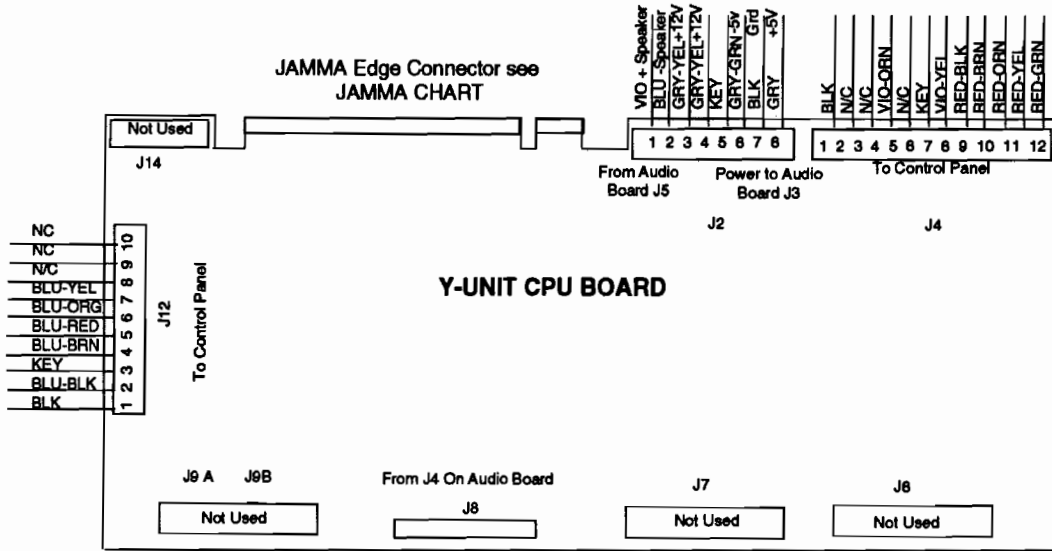

Coin Switch and Meter Wiring

Option 1

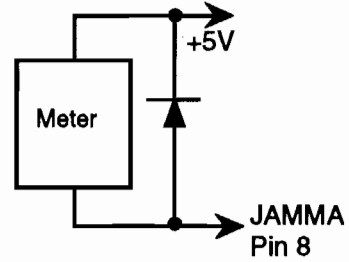
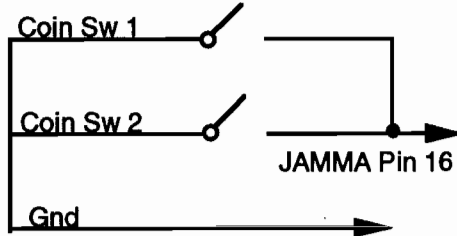

Option 2

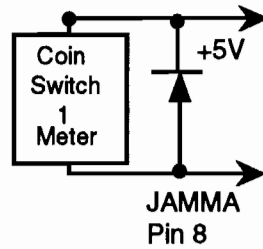
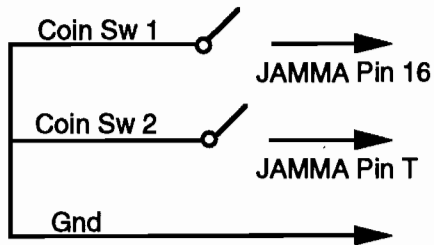

Wrong Way !

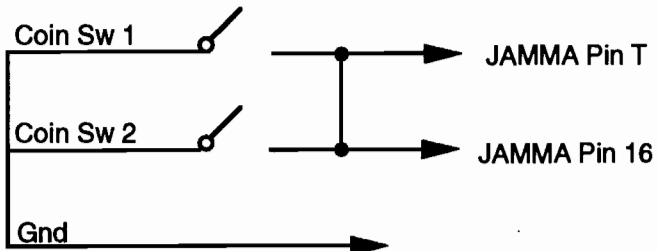

**Do NOT Connect the coin switches this way.
This Circuit is INCORRECT and will cause twice as
many credits per coin.**

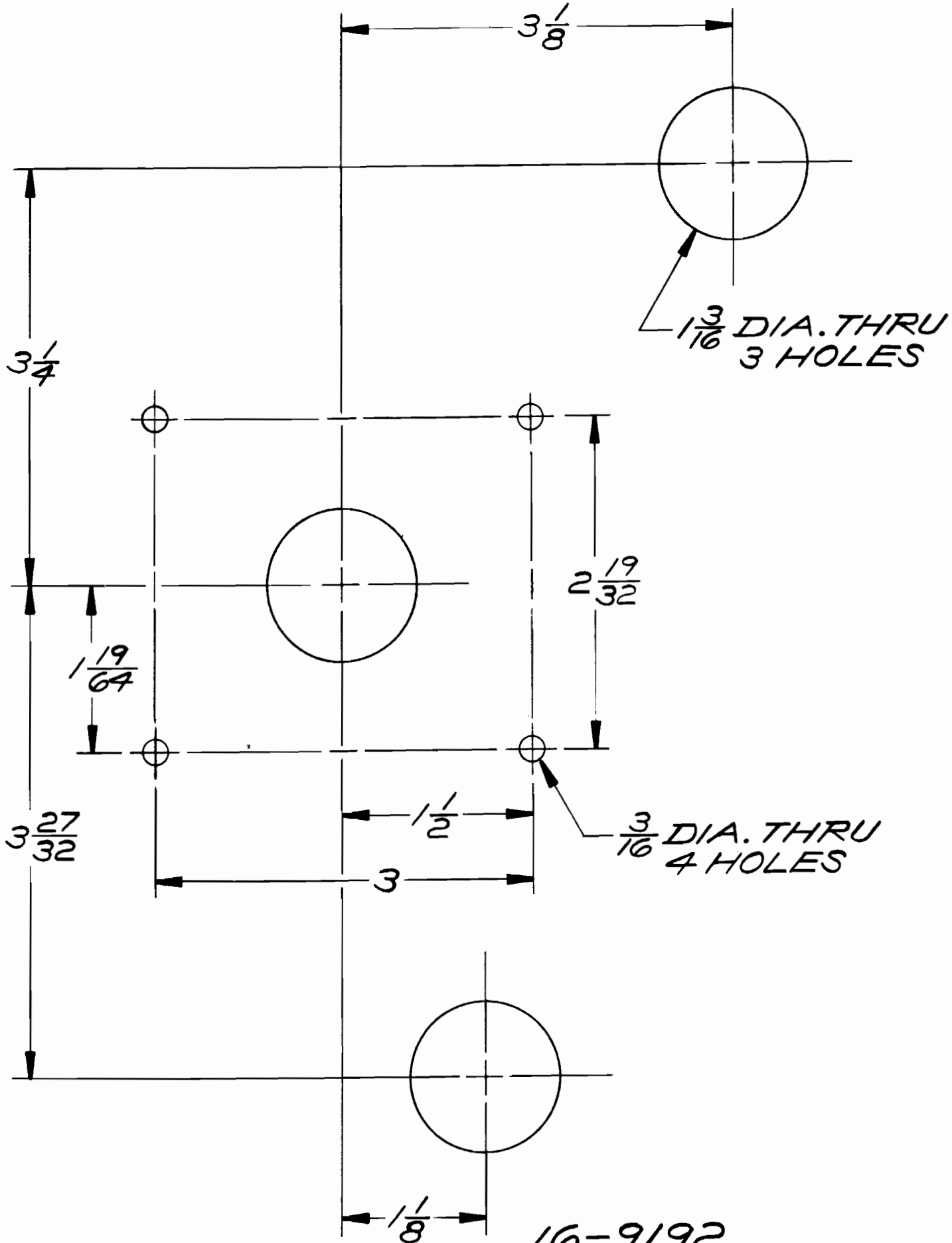

16-9192
 TEMPLATE CONTROLS
 PLAYER #1
 USED ON 40104 KIT

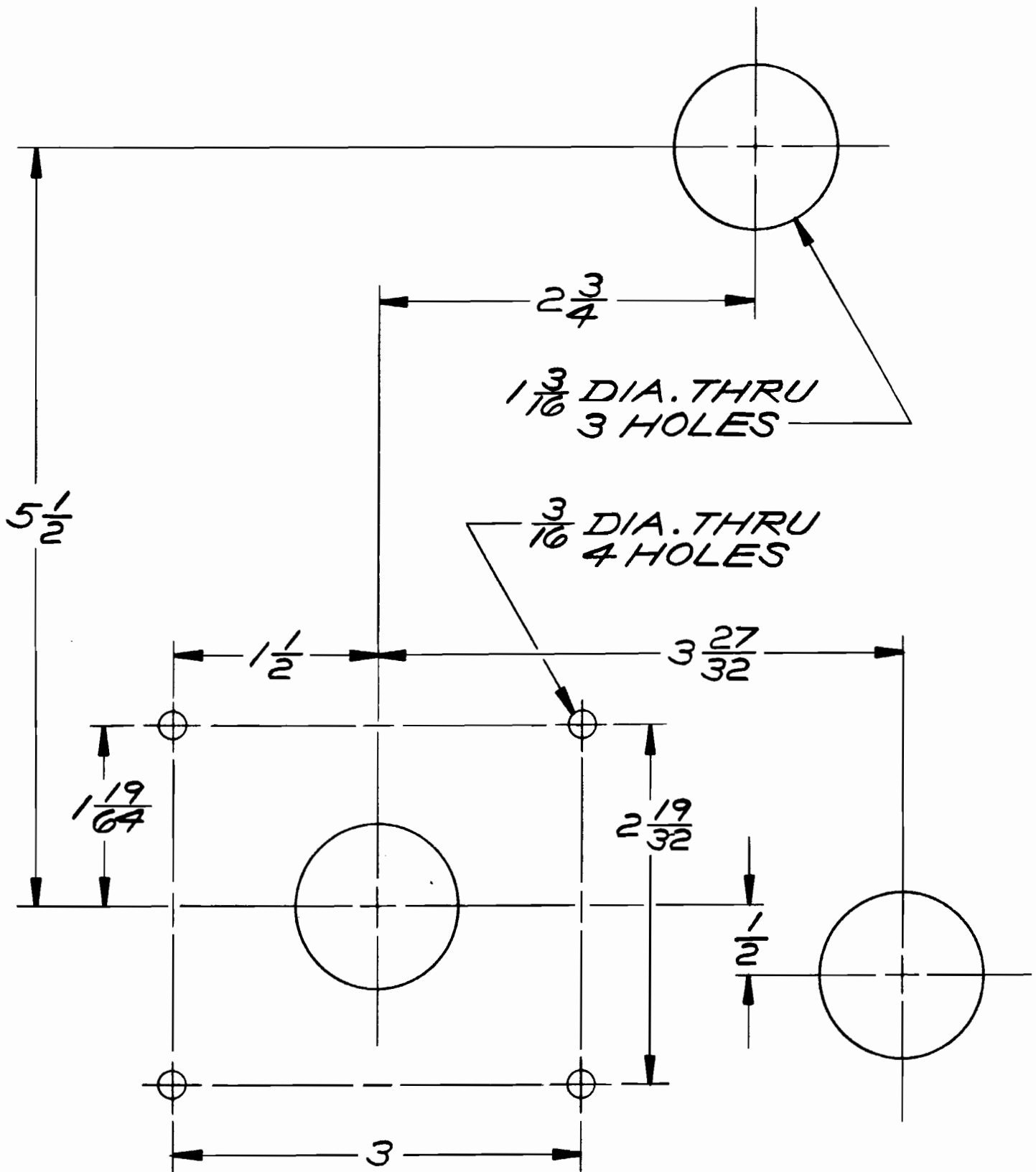

16-9192-1
 TEMPLATE CONTROLS
 3-24 PLAYER #2
 USED ON 40104 KIT

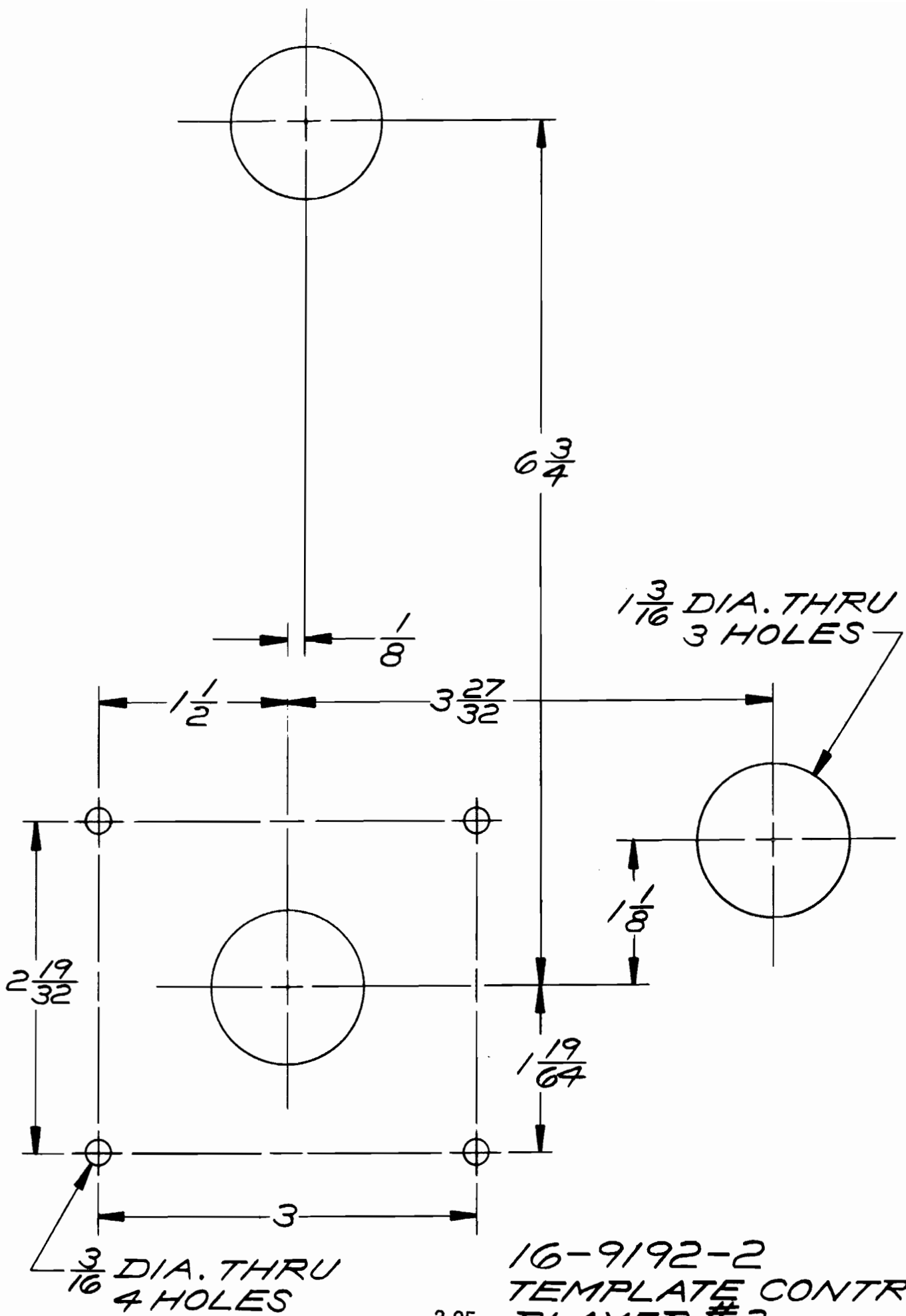

3-25

16-9192-2
 TEMPLATE CONTROLS
 PLAYER #3
 USED ON 40104 KIT

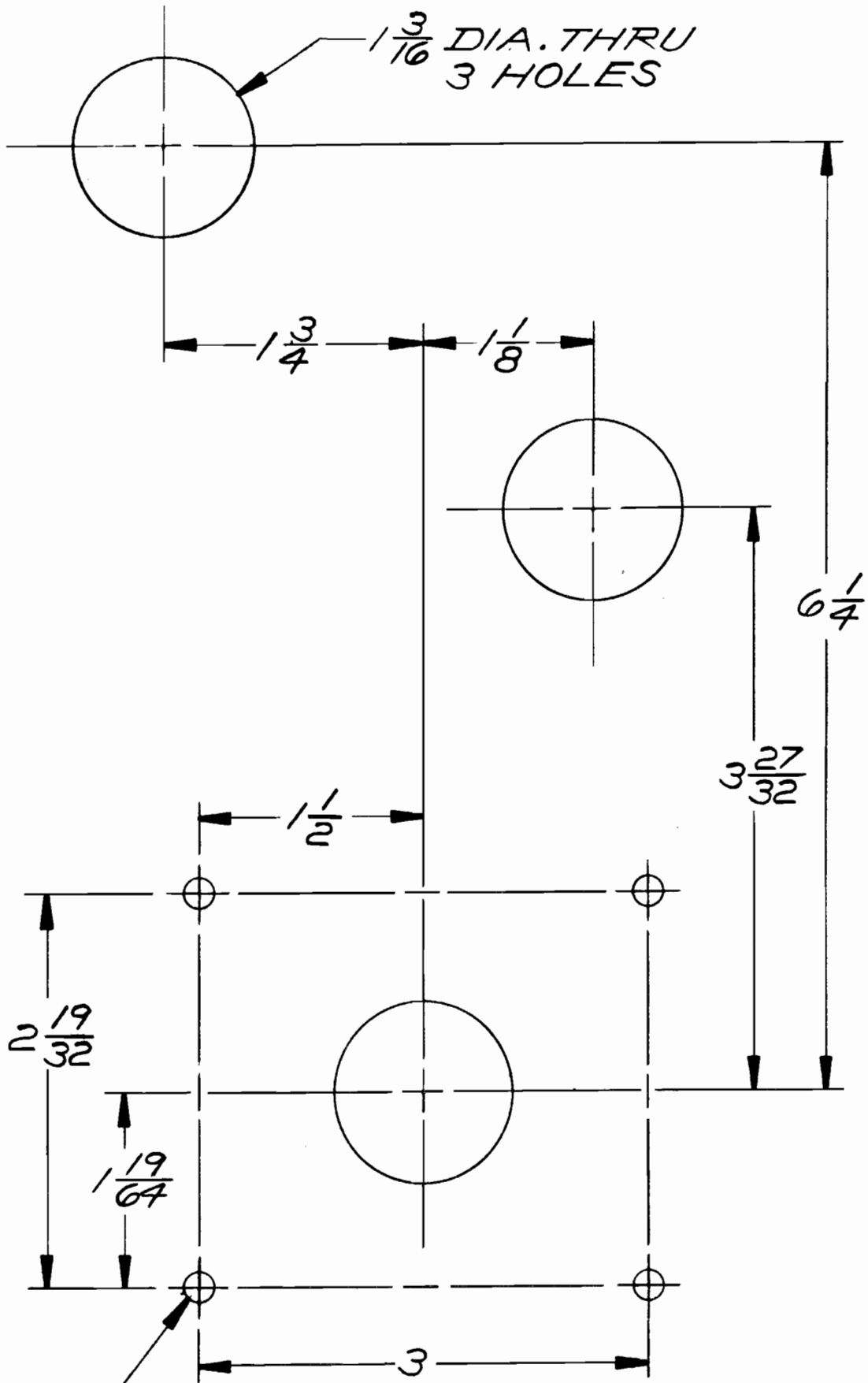

16-9192-3
 TEMPLATE CONTROLS
 PLAYER #4
 USED ON 40104 KIT

NOTES:

WARNINGS & NOTICES

Warning

USE OF NON-WILLIAMS PARTS OR CIRCUIT MODIFICATIONS MAY CAUSE SERIOUS INJURY OR EQUIPMENT DAMAGE! USE ONLY WILLIAMS AUTHORIZED PARTS.

* For safety and reliability, substitute parts and modifications are not recommended.

* Substitute parts or modifications may void FCC type acceptance.

* This game is protected by federal copyright, trademark and patent laws. Unauthorized modifications may be illegal under Federal law. This also applies to WILLIAMS logos, designs, publications and assemblies. Moreover, facsimiles of WILLIAMS equipment (or any feature thereof) may be illegal under federal law, regardless of whether or not such facsimiles are manufactured with WILLIAMS components.

Warning

This equipment generates, uses and can emit radio frequency energy and, if not installed properly and used according to the directions in this manual, may cause interference to radio communications. It has been tested and found to comply with the limits for a Class A computing device pursuant to Subpart J of part 15 of FCC rules which are designed to provide reasonable protection against such interference when operated in a commercial environment. Operation of this equipment in a residential area is likely to cause interference to radio communications, in which the user, at his or her own expense, will be required to take whatever measures may be needed to correct the interference.

Warning

Prevent shock hazard and assure proper game operation. Only plug this game into a properly grounded outlet. Do not use a cheater plug to defeat the power cord's grounding pin. Do not cut off the ground pin.

Notice

When Williams Electronics ships a game, it is in compliance with FCC regulations. Your sticker is proof. If the sticker is missing or damaged, legal repercussions to the owner or distributor of the game may result. If your game kit does not contain an FCC sticker, call Williams Electronics immediately.

Notice

No part of this publication may be reproduced by any mechanical, photographic, or electronic process, or in the form of a phonographic recording, nor may be transmitted, or otherwise copied for public or private use, without permission from the publisher.

Entire contents of this manual copyright © 1990 WILLIAMS ELECTRONICS GAMES, INC. All Rights Reserved.

WILLIAMS ELECTRONICS GAMES, INC.
3401 N. CALIFORNIA AVE.
CHICAGO, IL 60618

**FOR SERVICE:
CALL YOUR AUTHORIZED WILLIAMS DISTRIBUTOR.**