

GamePlan, inc.

GAME PLAN, INC.
1515 W. Fullerton Avenue
Addison, Illinois 60101
Telephone: (312) 628-8200
TLX 20-6098

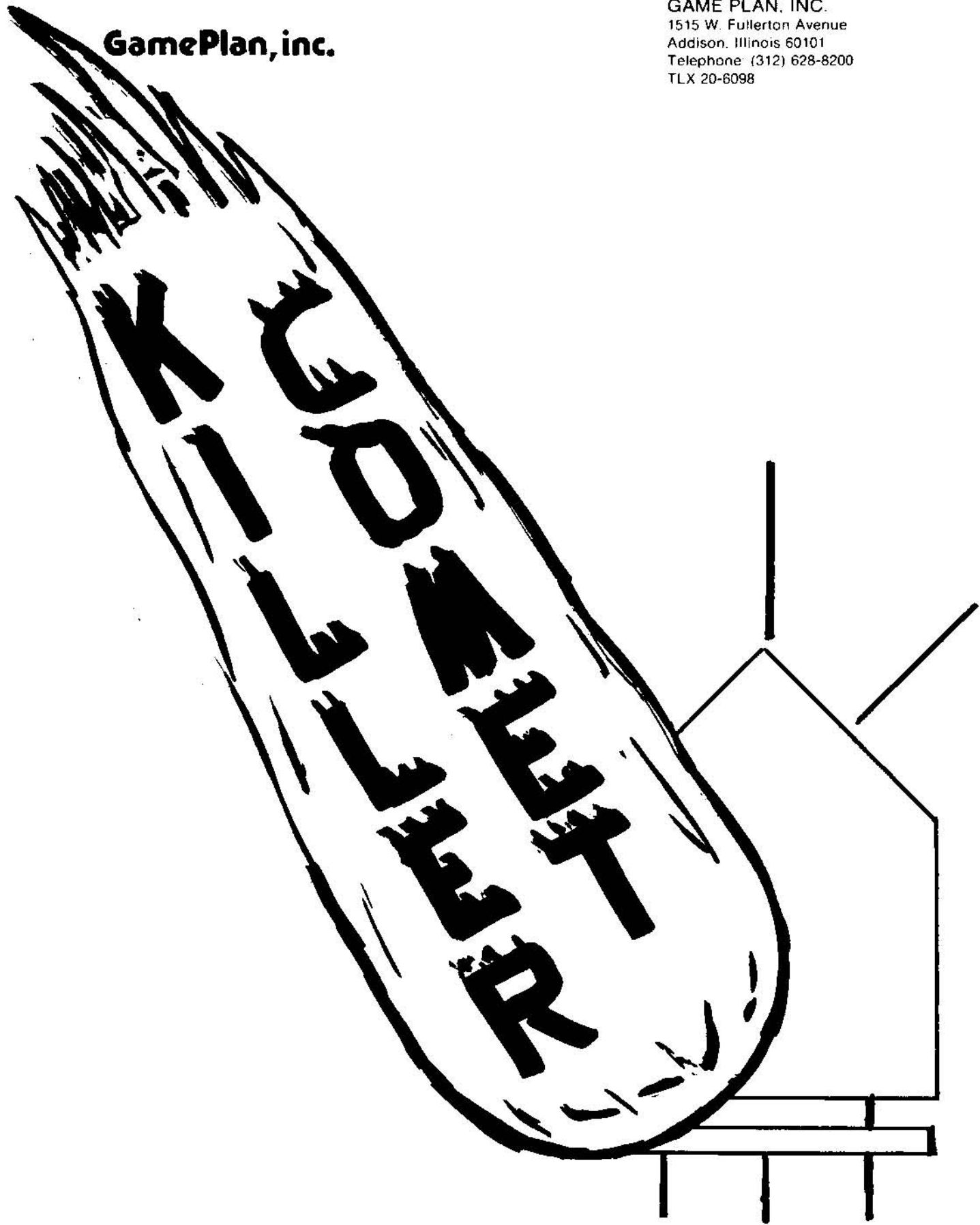

1.0 INTRODUCTION

Killer Comet is a full color one or two player action game that offers features guaranteed to capture and prolong player interest. Controls for movement, (Joystick & Hyperspace) and tri-directional Laser Fire, allow the player to steer his spaceship around the screen. The video and audio systems work together to make Killer Comet an excitingly colorful game with a variety of sounds.

1.1 UNPACKING INSPECTION

To ensure the equipment incurred no damage in shipment, inspect the container prior to acceptance from the carrier. If no immediate cabinet damage is evident, perform the following visual inspection:

1. Open the rear of the game with the appropriate packaged key.
2. Examine each major and electrical component thoroughly for scrapes, broken or missing parts and loose or missing screws.
3. Check for loose cable connectors.
4. Visually verify that all the integrated circuit devices (IC's) plugged into sockets are properly seated and that no IC pins are bent or misaligned.

If you find any damage during this inspection, file a claim with the freight carrier, and send a complete report of the damage to Game Plan Inc.

1.2 INSTALLATION

Planning the location of the game should involve both physical and electrical consideration. Physical considerations concern the placement of the equipment with respect to clearances, AC cable and environmental conditions such as ventilation, temperature, weight support and accessibility (although your game has the durability to endure nearly every type of physical hazard). Electrical considerations include availability of the correct voltage and frequency.

In planning this installation, consideration must also be given to working space required for personnel involved with operation or maintenance of this system.

NOTE: The cabinet must be within six feet of an AC outlet. Be certain that a ground jack or terminal is available at the outlet.

CAUTION: DO NOT remove the AC ground prong from the plug.

- A. Install 4 provided levelers to bottom of cabinet and level cabinet.
- B. The power is controlled by a switch located on top of the cabinet plug into A.C. only 115 volt 60 cycle.

CAUTION:

1. Do not install this game in places directly exposed to sunlight or excessive heat, to prevent rising internal temperatures.
2. High voltage runs the monitor. Therefore only persons familiar with safety measures should make any adjustments.
3. As with any solid state games the power should be turned off before replacing any parts or disconnecting any plugs.
4. Always take boards to distributor for repair, do not attempt to make any repairs with volt-ohmmeter or other test equipment as the internal voltage of such equipment may damage the circuitry.

1.3 PRELIMINARY CHECKOUT PROCEDURE

After properly installing Killer Comet, we suggest checking it's operation in the following procedure:

1. Plug the AC jack into the AC outlet.
2. Allow one to two minutes for CRT to warm up.
3. Observe the TV monitor display to assure the correct attract mode is present on the screen, as explained in Section 2.2.
4. If the Killer Comet display is incorrect, correct immediately.
5. Insert a quarter into the coin slot.
6. Continue to play the game and verify that all screen images are displayed, once again, described in the Normal Operation procedure.

If repairs are necessary, contact your distributor or Game Plan Inc.

2.0 GAME DESCRIPTION

The following paragraphs describe the video images, sound effects, game strategy.

2.1 RESET MODE

Whenever power is applied (or momentarily interrupted), or the slam switch is activated, the game generates a 2 second siren blast. This serves two purposes:

First, when game-power is applied, the video monitor requires several minutes for warm-up, but the computer is ready in less than a second. The siren sound (or it's absence) thus provides immediate information concerning a normal power-up sequence of the computer electronics.

Second, the siren sound alerts the operator if someone tampers with the machine on location. It will even serve to discourage tampering by its psychological effect.

In addition, a power-on or slam reset causes the video screen to glow bright red for 3 seconds.

2.2 ATTRACT MODE

After power-up, Killer Comet automatically cycles thru 3 video image displays that constitute an attract mode intended to inform new players about the game, to entice them to play, and to enhance repeat-play. During the attract mode, all game sounds and player controls are deactivated by the computer program.

2.2.1 The Message Display appears first and stays on-screen for 8 seconds. The background is changed to a soft-green to highlight the messages which include:

The 3 digit player scores (initially preset to 000). Player-1 score is in the upper-left and is in the Player-1 color of cyan (light blue). Player-2 color is yellow.

The 3-digit best score is displayed (in white) in the top-center and is initially preset to 047.

The number of credits (in blue) is limited to a single digit which is preset to 0 unless the "free-play" option is selected, in which case credits are preset to the maximum of 9.

The next 2 lines inform the player that he will receive 1 credit for each coin and that either 1 or 2 can play.

The Killer Comet logo is then displayed and highlighted by a brilliant color-flash in its border.

The next 2 lines display the selected credit option (see section 5.0).

2.2.2

The next screen image in the attract mode is the Simulated Game Display. The screen background changes from green to black and the player-scores, best-score, and credits appear as in message mode with the Killer Comet logo moved to upper-left. A 3rd line displays 4 or 5 numbered spacepods for each player in their colors.

At the top of the playfield, 8 different, multicolored monsters appear in random positions and move in random directions toward the bottom of the screen. Each monster begins dropping a unique style bomb which explodes with a flash when it reaches the bottom.

2.2.2 A spacepod appears at the top-center, drifts down, and begins to float around the screen. At random intervals, the spacepod fires laser energy beams in 3 different directions. If one of these lasers hits a monster, or a bomb, it explodes with a flash. The monster reappears somewhere in the upper portion of the screen. Also, anytime a monster reaches the bottom of the playfield, it disappears and reappears in the upper playfield.

If the spacepod is hit by a bomb, it explodes with a large flash. Even worse, if the spacepod gets too close to a monster the monster jumps on top of it and devours it. When either of these 2 events occur, the display is completed.

This simulated game shows a potential player most of the salient features such as: being able to fly the spacepod anywhere on the screen, the availability of 3 lasers with limited range, the variety of monsters and bombs, recycling the monsters, and the impending danger of being eaten. The one feature which is intentionally not shown, is the Killer Comet itself, for which he must pay and play.

2.2.3 The final image in the attract mode sequence is the Game-Over Display. The screen goes to a bright red background and only the interesting data is displayed, namely, player-scores, best-score, and the number of credits. None of the scores change during the attract mode, so they will continue to display either the initial conditions (after reset) or the results of the previous game.

After 5 seconds, the screen goes to the green message display and repeats the sequence.

2.3 COIN INPUT MODE

At all times, while power is on, regardless of the game conditions or the operator options, the computer will accept a coin input, generate a unique sound, and increment the coin counter. However, the credits will only be incremented if they are not already at the maximum of 9 and they will be displayed only during the attract and game-over modes. When in these modes, the coin-input software clears the screen to bright red and goes to the game over display so that, even when already in the game-over display, the screen will flash and the new credit count will be displayed. Thus a dramatic visual and audio feedback acknowledges the receipt of a coin.

2.4 GAME START MODE

The computer scans the game-start switches only during the attract and game over modes and only then if the credit-count is no-zero. When a start-switch is activated, the computer compares the operator selected credit option against the credit-count and ignores the switch if enough credits are not available. If there are sufficient credits, the computer subtracts the price of the selected game, resets the player scores to zero, generates the game-in-play (GIP) sound, and displays the GIP message.

2.4.1 THE GAME IN PLAY message has a soft blue background for highlighting the critical information of the number of spacepods (displayed graphically) and the player-up. Either 4 or 5 spacepods are displayed in each player's color (light blue for player 1 and yellow for player 2) and the pods are numbered with dark blue numerals. The only difference between 1 and 2 player start messages is that no second-player spacepods are displayed during the 1-player game.

"Player 1 UP" (in light blue) flashes 10 times, the screen goes black, and the game is ready for play.

2.5 SINGLE PLAYER GAME

The game-play sequence in Killer Comet consists of 4 or 5 turns (operator selectable) each of which lasts as long as the player can skillfully maneuver his spacepod to avoid destruction. When he loses a spacepod, the GIP message reappears, accompanied by the GIP sound, and displays the number of spacepods left. After the last spacepod is destroyed, an abrupt game-over sound is heard and the game-over message is displayed.

Assuming a 4 pod game, play begins with player-scores (000) and best score displayed across the top of the screen. Light blue spacepods, numbered 2, 3, and 4, are in the upper left and number 1 appears in the top-center drift-in towards the bottom. Eight purple monsters appear in the upper portion of the screen and move towards the bottom to the tune of a rhythmic background march, while dropping their red & white bombs. The player uses his joystick-control to fly the spacepod in a simulated gravity-free, space environment. The spacepod appears to float around the screen and does not change directions abruptly because it must decelerate and then accelerate in the new direction. Vertical motion of the spacepod is limited when it reaches the top or the bottom of the playfield. On the other hand, both the spacepod and the monster (and the Killer Comet) "wrap-around" the left and right edges of the screen.

If the spacepod gets trapped in a awkward location, the player can gamble on a "hyperspace move." When the hyperspace button is pressed, the spacepod disappears with a special sound effect and then reappears at a random location which, of course, could be right where a monster or bomb will destroy it immediately.

As the spacepod is maneuvered around, the player fires his laser energy-beams towards the left, right, or straight-up accompanied by an echoing laser sound effect. The laser beams have a limited range, covering about one-fourth of the playfield, but each spacepod has an unlimited number of shots. The 3 laser beams cannot be fired continuously. Each fire-button must be released and pressed again to fire a second shot. Also, there is a slight "reload" delay so that beams cannot be fired too rapidly.

Whenever a laser beam strikes a monster or a bomb it explodes with a visual flash and an audio blast. If a monster is blasted, the player is awarded a "kill" and his score is increased by 1. When a bomb is blasted, no points are scored.

At random times during the game, a glowing, colorful orb appears at the left or right edge of the playfield. This is the "Killer Comet", so-called because it is attracted to the spacepod and will follow the shortest path toward it and of course, the spacepod will be destroyed if the Comet gets too close. Fortunately, the Comet can be destroyed by a laser beam, but this requires skillful flying since the spacepod must maneuver below the Comet. If the Comet is blasted, it disappears (by getting smaller) and the player is awarded 1 kill. An alternative escape for the spacepod is to outrun (sometimes by using hyperspace drive) the Comet since it stays on the screen for a randomly limited length of time and then disappears. But, stay alert, new Comets will reappear at random times throughout the game no matter how many have been blasted.

The appearing Comet is introduced by an increasing crescendo sound effect followed by a rapid increase in the background rhythm. It disappears to a decreasing sound effect and the background march returns to a normal beat.

When a spacepod is hit by the comet or a bomb, it explodes with a growing flash and a reverberating blast. When the spacepod gets too close to a monster, the monster jumps up and sporadically devours it while growling and burping.

2.5 SINGLE PLAYER GAME CON'T

This ends the first turn and the video image returns to the GIP display, flashing "Player 1 Up" and displaying the remaining spacepods. The screen then goes black again and this time pod number 2 drifts down from top-center of the playfield and play continues as before.

During play, there are always 8 monsters on the screen, however, the monsters attack in waves of 25. After each multiple of 25 kills, the monsters begin to reappear as a new shape and color and drop a different type of bomb. At the beginning of play, the action is rather moderate to allow new players and opportunity to develop a "feel" for the game. After 15 seconds of play in each turn, the bombs begin to fall at an increased rate, and then after 30 seconds, bomb speed increases again. The bomb speed is also increased after 100 and 200 "kills" are scored. Also, the monster motions and the Comet speed increase after 150 kills. As time progresses, the Comet enters from a progressively lower position making it difficult to maneuver the spacepod below it.

All of these features combine to make Killer Comet satisfying for the novice, challenging for the expert, and profitable for the operator.

2.6 TWO-PLAYER MODE

The play of Killer Comet in a two-player game is identical to single-play with the players alternating turns. On the Upright Version, the players use one common set of controls. On the cocktail version there are two sets of controls on opposite sides of the table. The computer activates control alternately between player 1 and 2 and flip-flops the screen image so that it is oriented to the player in control.

The GIP message, which appears after each turn, clearly indicates which player is up by flashing it in the player's color. This also allows time for the players to position themselves at the controls, but is brief enough to avoid unnecessary "dead-time". The use of two different player-colors eliminates any confusion as to which player is in control.

2.7 GAME OVER MODE

After the players have lost their last spacepod an abrupt game-over sound is generated and the screen is cleared to bright red. This provides a dramatic visual and audio impact which eliminates the need for the trite (and negative) message "game-over". Instead, the interesting information is displayed; the player scores, the best score, and the credit count.

Highlighting the credit-count, displayed near the middle of the screen, is intended to induce the players to insert more coins and immediately press a start-button, thereby minimizing "dead-time".

3.0 COMPUTER SYSTEM

Killer Comets Computer System consists of 4 printed-circuit assemblies which perform the functions illustrated in figure I. A self-contained switching regulated power supply provides reliable DC voltages to enhance the overall computer system reliability.

The Game Computer Board controls the game sequence, image generation, and system-level diagnostics.

The Video Computer Board contains the display RAM and the timing circuits to interface with any standard RGB raster-scan color monitor (RGB-Red-Green-Blue). The Video Computer also contains unique input timing circuits which permit vector graphic (color-dot-oriented) writing to the video RAM. Thus the GAMMA-II system provides the ultimate combination of vector-scan and raster-scan techniques.

The Audio Computer Board contains an independent processor which is dedicated to the generation of audio effects. Thus, a large variety of sounds are available for this game and , by simply exchanging a ROM, an unlimited number of sounds are available for future games.

The Peripheral Interface Board contains buffers and drives which provide I/O (input/output) for the computer system. It interfaces with the player-control panel switches and with the coin door switches, meters, and lamps.

3.1 POWER SUPPLY

The computer system power is provided by a high efficiency, very reliable, switching-regulated, power supply. It eliminates the hot, bulky transformers required by old-fashioned supplies and the high efficiency permits it to run cool at extremes of input line voltage variations.

The computer system uses -5, +5, and +12 VDC. The primary power is +5 VDC for the TTL and MOS divices. The ROM's can be either triple-voltage or single-voltage. The dynamic video RAM's use all 3 voltages. The audio amplifier uses +12 VDC. The coin door lamps and meters use +5 VDC.

DC voltage distribution form the power supply to the four circuit boards is multiply-redundant to enhance reliability. Each voltage is carried by two wires to each board. All four power connectors are identical, are keyed, and are symmetrical, so that only intentional abuse could result in faulty power connections. Each of the three voltages is current-limited by the supply to provide protection against short-circuits.

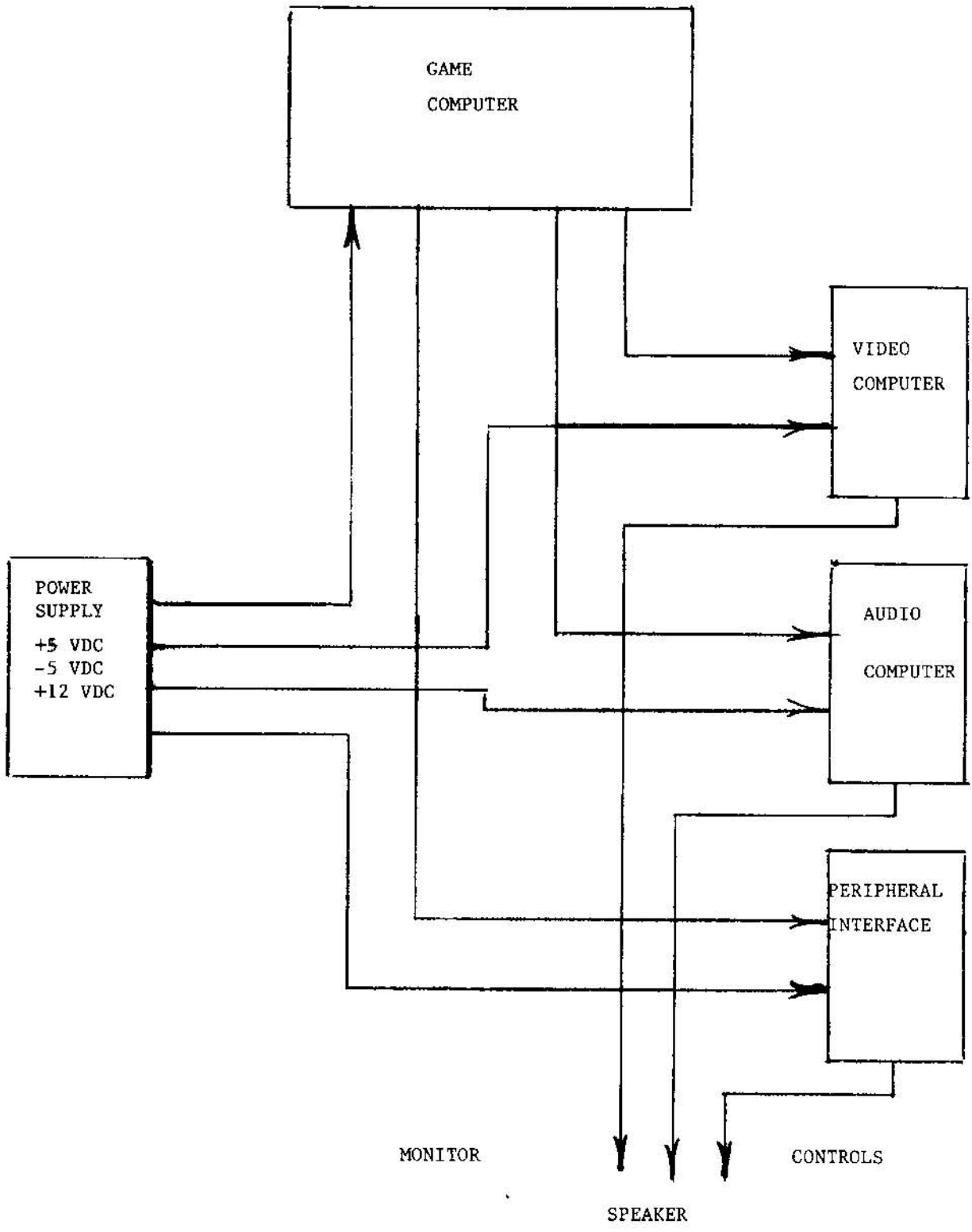

FIG. I
KILLER COMET (BLOCK DIAGRAM)

3.2 GAME COMPUTER

The Game Computer uses a 6502 central processor in a conventional computer architecture containing ROM, RAM and I/O ports as illustrated in figure 2. The computer clock uses a standard 3.579 megahertz TV color-burst crystal, which is divided by 4 to provide a CPU clock of less than 900 kilohertz. This is 10% below the rated frequency and provides a comfortable reliability margin.

The computer contains a unique power-on reset circuit which requires a positive feedback response from the computer to disable the reset circuit. Therefore, an initial power-on software program must successfully complete a specific set of operations or else the circuit continuously resets the computer. This technique assures that the computer is operating properly before continuing but does not require the software overhead of "watchdog" circuits.

Conventional TTL address decoding generates signals to select one of eight ROM's, or two RAM's or one of three ports. Program and image storage is provided by eight 2K x 8 2716 EPROM's or 2316 ROM's. Computer scratch-pad RAM is either two 1K x 4 2114's or two 256 x 4 2101's.

The three I/O ports are 6522's which are each dual bidirectional data-bus buffers with internal timers and shift-registers. One of each of these ports is dedicated to interface with each of the three functional subsystems required for game operation.

Port 1 provides an 8-Bit video data byte on port 1A and a 4-Bit video control address on Port 1B to write data into the video RAM. In addition, port 2B receives video timing signals which are used to synchronize the game program with the video display.

Port 2 uses port 2A & 2B to create an 8 x 8 switch matrix for scanning up to 64 switches. Two columns of this matrix are used on-board to scan two 8-position DIP switches providing operator options. The remaining switches are routed thru the Peripheral Interface Board. Port 2 also provides signals for driving coin meters and other peripheral devices. In addition, Port 2 is linked to the power-on reset circuit so that the computer can enable or disable the reset signal.

Port 3 transmits a sound-request signal on Port 3A and receives an acknowledge signal on Port 3B to provide a handshake between the Game Computer and the Audio Computer.

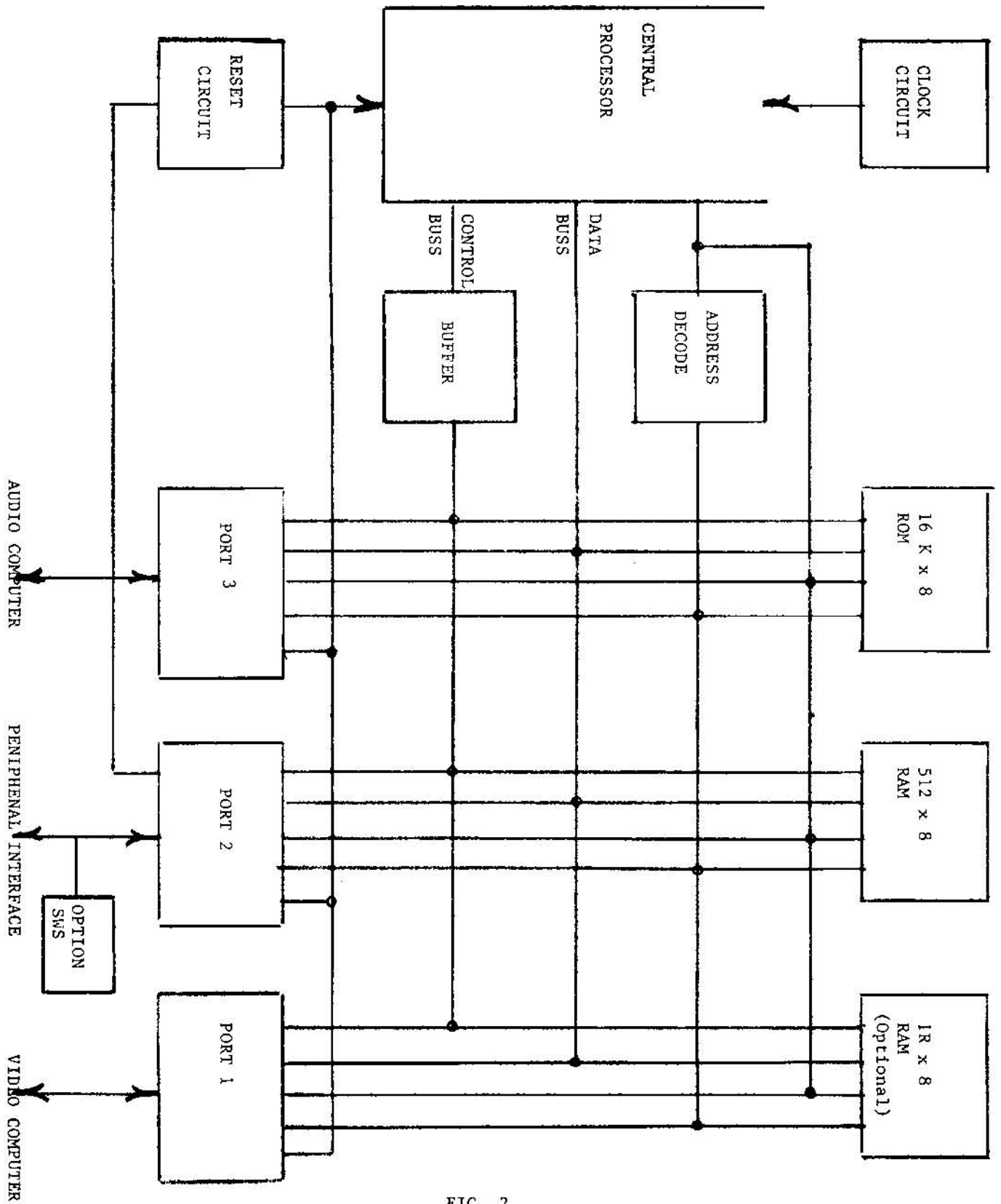

FIG. 2
BLOCK DIAGRAM COMPUTER BOARD

3.3 VIDEO COMPUTER

The Video System uses a RAM intensive, dot-oriented technique. What this means is that the circuit board contains sufficient memory to store an entire CRT screen image and that each bit in this RAM array can be individually addressed.

The large memory array is comprised of low-cost MOS dynamic RAM's which are ideally suited for video display. The repetitive reading of the memory for raster scan display automatically takes care of the refresh timing required to retain dynamic memory. On the other hand, dynamic RAM's are notoriously unreliable (by digital computer standards) but occasional bit errors are tolerable (in fact, often invisible) on a CRT screen. Some systems use part of the video RAM for computer scratch-pad but the video computer appears to the game computer as a "write-only" device.

As illustrated in figure 3, the Video Computer contains 3 separate RAM arrays for each of the 3 spectral primary colors; red, green, and blue. Two independent sets of counters generate read and write addresses that access the 3 arrays in parallel to generate color dots (pixels). The read-address counters perform the dual function of generating horizontal and vertical timing signals for synchronization of the CRT monitor and the Game Computer image generation.

The write-address counters are parallel-load, up,-down devices which provide 2 modes of writing to the display memory. In the first mode, the write-counters can be loaded with a 8-bit X-address and an 8-bit Y-address to locate the beginning of a line vector. The second mode involves incrementing or decrementing the counters to move the write-address along a desired vector. Each time a write-address is changed, the Video Computer automatically writes the specified color bits into that RAM location.

A Write-request to the Video computer is non-synchronous so timing buffers interface the read and write functions. In addition, the timing buffers generate "wait" signals to let the Game Computer know when each write operation is completed.

The 8-bit X-Y addressing generates a 256 x 256 screen image (256 dots per line and 256 lines per game screen. This symmetrical display combined with the vector graphic writing technique provides simple software control of the screen image orientation. Thus the system provides switch selection to use vertical or horizontal monitors, inverted screen for cocktail flipflop of 2-player games, and reversed images for mirrored games.

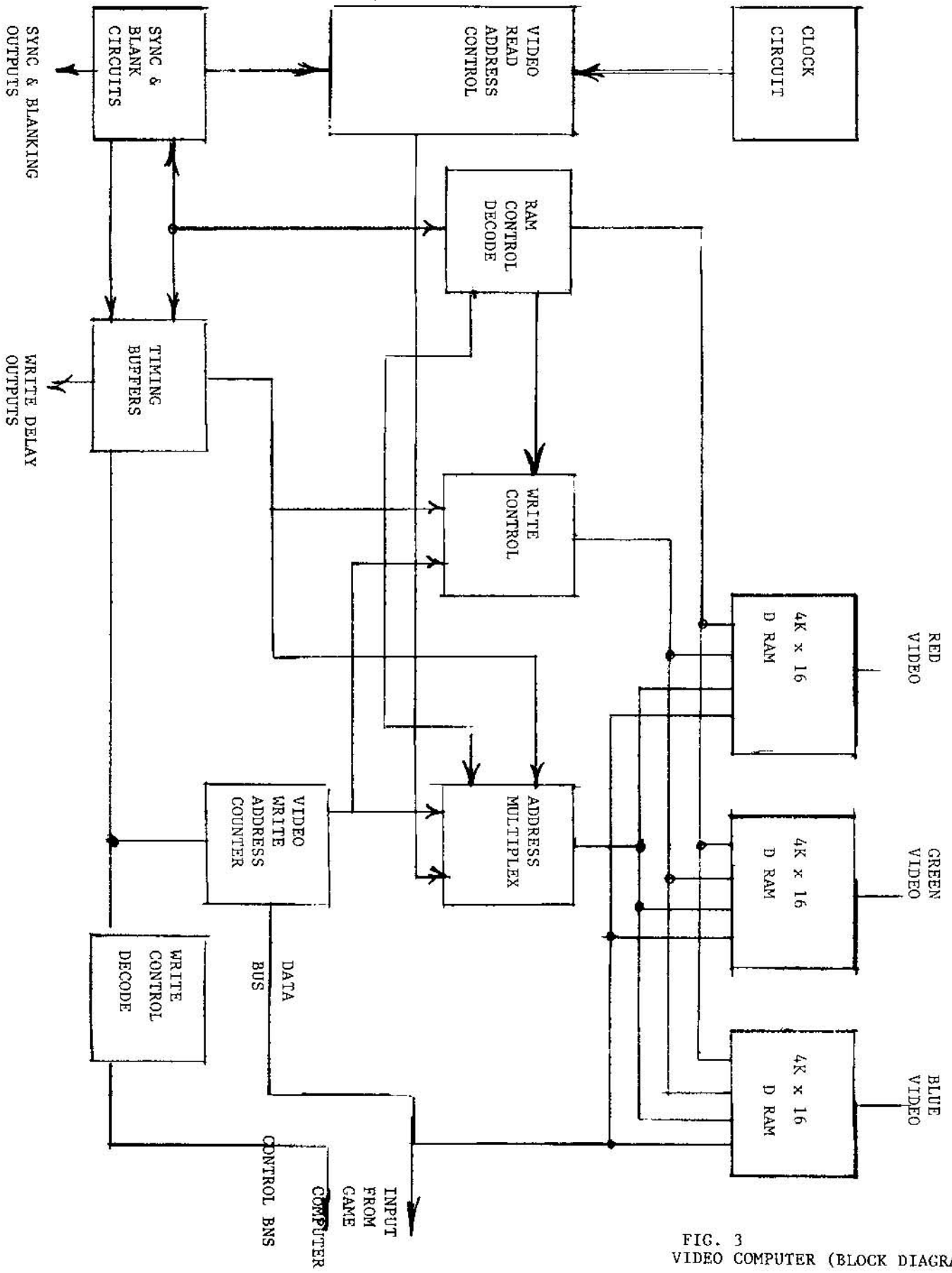

FIG. 3
VIDEO COMPUTER (BLOCK DIAGRAM)

3.4 AUDIO COMPUTER

The Audio Computer also uses a 6502 central processor chip as illustrated in figure 4 and it also uses a standard TV color-burst crystal to generate a computer clock slightly less than 900 kilohertz. However, Port 5 uses a 6532 which provides dual 8-Bit bidirectional data-bus buffers plus 128 bytes of RAM. Program storage is provided by a single 2K x 8, 2716 EPROM or 2316 ROM.

The small amount of RAM and ROM is sufficient for this system because of the use of a unique programable sound generator chip (AY-3-8910 PSG). This device contains 3 sets of tone generators, a pseudo-noise generator, and 3 channels with a variety of amplitude controls-all under stored-program control. In addition, the PSG contains two 8-Bit ports which are used to read two DIP switches that can be used to manually program the PSG for test purposes.

Access to the Audio Computer is through Port 5A which interrupts the processor when a sound-request is made. The computer stores the sound request data-byte and then re-transmits it on Port 5B. Thus the Game Computer can verify that a requested sound has been processed and, if this verification is not received, the Game Computer can force a reset of the Audio Computer.

The 3 audio channel outputs of the PSG are amplified by an industry-standard, reliable LM 380. The amplifier operates with regulated 12 VDC which provides sufficient audio volume for noisy arcades, and yet is only 60% of the rated voltage to provide another margin of reliability.

A volume control is located on the Audio Computer Board. Individual game sound volumes are programmed to balance the overall audio effect.

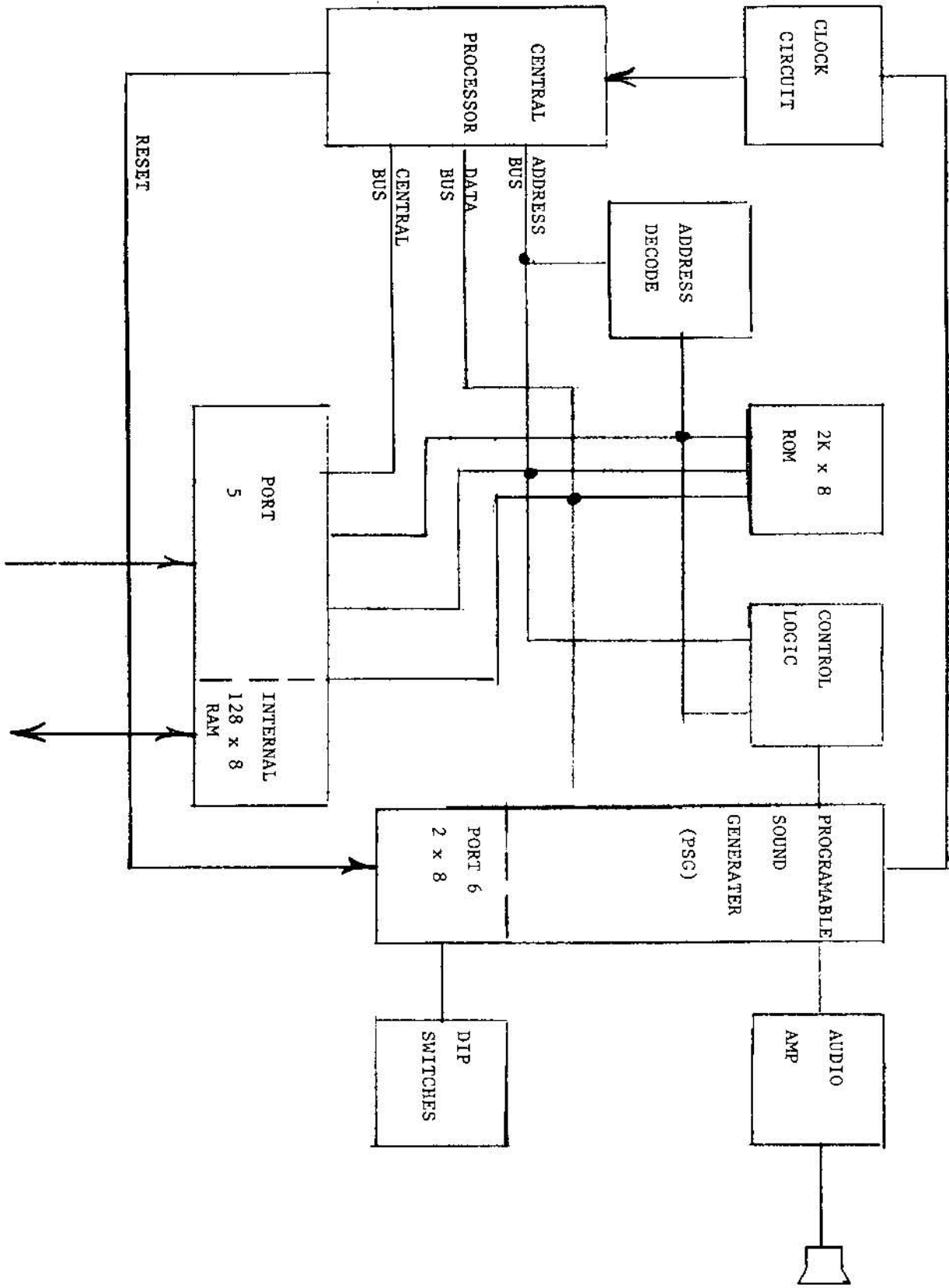

FIG. 4
AUDIO COMPUTER (BLOCK DIAGRAM)

3.5 PERIPHERAL INTERFACE

The Peripheral Interface Board provides buffers and drivers for protective isolation of the electronics. Up to 48 switches can be handled by 6 columns of a switch matrix, as illustrated in figure 5. Each switch is "diode-isolated" to provide "n-key rollover". The potential problems of ghost-switches is also eliminated by putting all critical, non-player-accessable switches in a single column.

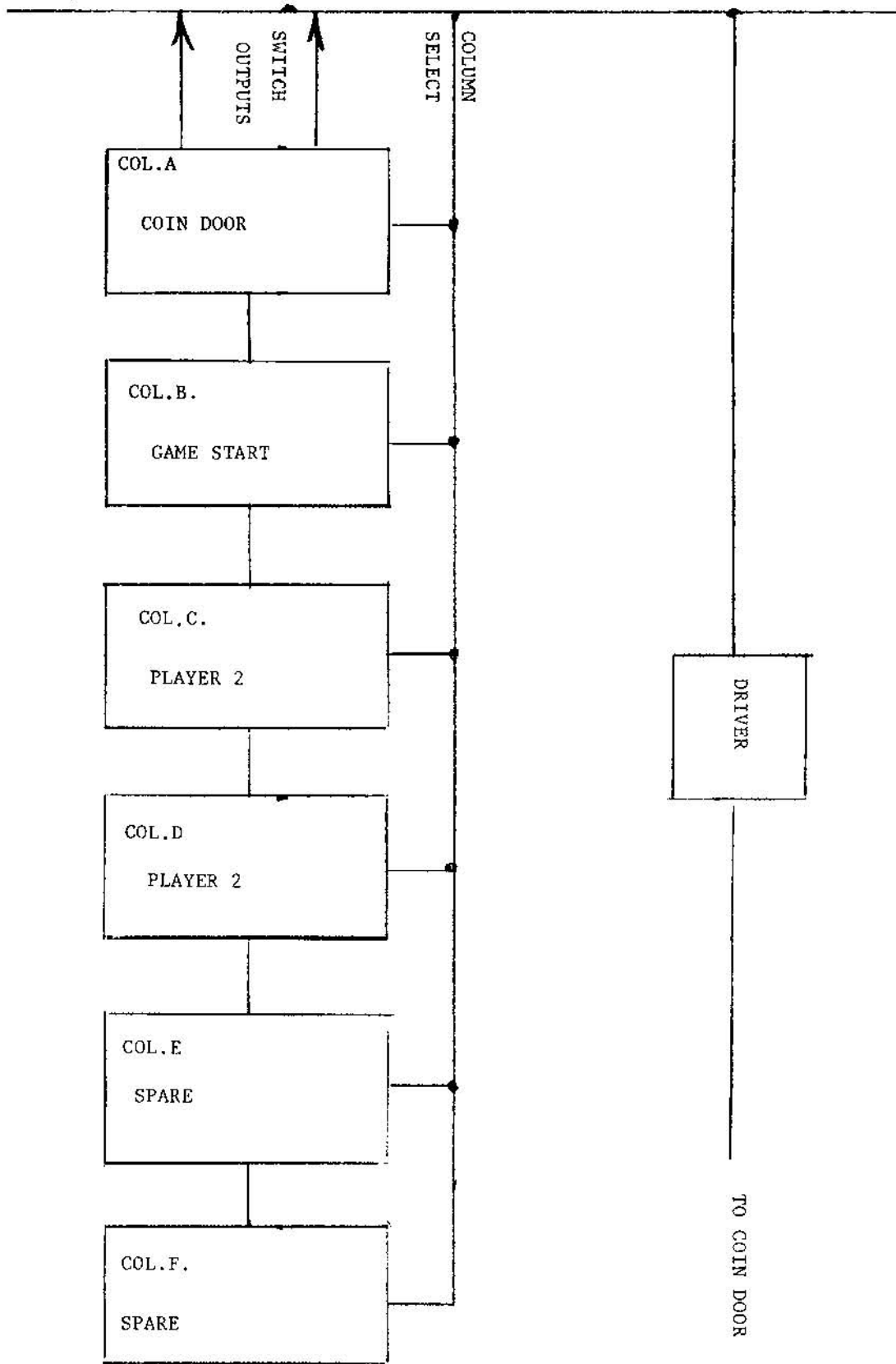

FIG. 5
 PEIPHERAL INTERFACE (BLOCK DIAGRAM)

The Killer Comet game includes a very comprehensive set of system-level, self-diagnostics. These diagnostics consist of the 10 selections listed below:

Mode 0: Diagnostic Menu	Mode 5: Video Ram Locator
Mode 1: Color Fields	Mode 6: DIP Switches
Mode 2: Color Grids	Mode 7: Coin & Start Switches
Mode 3: Continuous Video Clear	Mode 8: Player Switches
Mode 4: Continuous Video Write	Mode 9: Audio Computer

At any time that power is on, regardless of the state of the game or the setting of operator options, the Diagnostic Test Mode may be entered by activating the Test-Switch located on the coin-door. This test-switch has two positions: One side is a momentary-action position and the first time it is pressed, the diagnostic menu displays the above list of test selections. Each subsequent depression of the switch, steps to the next sequential test mode with mode 0 (the menu) following mode 9. If the lever is held in this position, the test modes are automatically sequenced until the lever is released. The other side of the test-switch lever is a detent-position which is used to perform special tests within some of the test modes.

Details of the test modes, their displays, and useful test techniques, are presented in the following section.

Exit from the test modes is automatic in the sense that activation of any coin-switch or the slam-switch automatically returns the game to the attract mode. Test mode 7 is used to test the coin-switches so it can only be exited by stepping to another test mode or by interrupting the power.

TEST MODE 0

SYSTEM DIAGNOSTIC

The self-diagnostic test modes in Killer Comet are entered thru the test-switch located on the coin-door. The test modes are exited by activating the slam-switch or a coin-switch (except in test no. 7) or by interrupting the power. Entry to the test modes is sequential with mode 0, the Diagnostic Menu, appearing on the screen first and after mode 9, when the test selection is cyclically sequenced thru all test modes.

The Diagnostic Menu display is essentially a "table of contents" which eliminates the need to constantly refer back to manuals. The menu illustrates a general theme of this Diagnostic System in the sense that, within practical limits, the diagnostics should be self-explanatory and tutorial. Also, these diagnostics are primarily system-level (game-level, as opposed to circuit level) to serve the needs of an operator-serviceman setting-up or checking-out an on-site game.

TEST MODE 1

COLOR FIELDS

Test modes 1 and 2 comprise a built-in, color-bar generator which is required to properly set-up the color monitor for color purity, static and dynamic convergence, and white balance.

Test Mode 1 also illustrates the use of the detent position of the test switch. When mode 1 is first entered, the screen goes all black with the message "EST NO. 1 COLOR FIELDS" displayed in white at the top of the screen. If the test switch lever is moved and left in the detent position, the screen will automatically sequence cyclically thru 8 color fields (solid color rasters).

RED
GREEN
YELLOW (RED & GREEN)
BLUE
MAGENTA (RED & BLUE)
CYAN (GREEN & BLUE)
WHITE (ALL ON)
BLACK (ALL OFF)

Any one of these color fields can be selected by returning the test switch to the neutral position.

If the user should inadvertently leave the test switch in the detent position it will no cause any problems with respect to existing the Diagnostics or with normal game play.

TEST MODE 2

COLOR GRIDS

Test 2 displays color crosshatch patterns. As in test 1, the detent position of the test switch can be used to select any one of the 8 colors.

These grids should be used to periodically check the monitor set-up for:

IMAGE SIZE
POSITION
SYNCHRONIZATION
LINEARITY
PINCUSHIONING
COLOR CONVERGENCE
COLOR BALANCE

Image focus and brightness (Kinematic bias) should be a final adjustment made on-site with the game in play.

The color grids fill the total image display on the monitor screen so that size and position adjustments of the grids relate directly to the game image.

TEST MODE 3

CONTINUOUS VIDEO CLEAR

Test modes 3 and 4 are primarily intended as circuit-level tests but they are included in these system-level diagnostics because they relate to the interaction of the Game Computer and Video Computer. The idea is to provide repetitive "clear" and write " signal so that functions can be observed with synchronous test equipment such as oscilloscopes.

When test No. 3 is entered, the screen will go solid blue with "TEST NO. 3 CON'T. VIDEO CLEAR" displayed across the top in black. After a 2 second delay the screen will begin flashing indicating that repetitive "clear-to-blue" signals are being processed.

TEST MODE 4

CONTINUOUS VIDEO WRITE

When test mode 4 is entered the monitor screen will be cleared to all black and "TEST NO. 4 CONT. VIDEO WRITE" will be displayed across the top in white. After a 2 second delay a white diagonal line will appear from the upper-left to the lower right. Although not apparent to the viewer this line is being constantly redrawn to force the video X-Y write-counters to cycle thru binary up-counts.

A feature of this test mode is that since the video RAMS are being continuously accessed, errors from defective or marginal RAMS will appear as spurious dots on the screen and, when errors are observed, the next test mode can then be entered to determine which RAMS are generating the erroneous dots.

TEST MODE 5

VIDEO RAM LOCATOR

Test 5 is a unique diagnostic aid that uses the video display and the hardware configuration of the video computer to isolate problems down to the chip level. There are 48 video RAM chips that are socketed and arranged in three groups of 16 corresponding to the 3 primary colors, red, green, and blue. As described in test 4, whenever one of these RAMS is defective, spurious colored dots will appear on the screen. When test 5 is entered, the screen is not cleared so that the noise dots still appear.

16 vertical, white lines are spaced across the screen and 3 pairs of letter-numbers appear in the middle of the screen. These letter-number pairs are "road-map" locators corresponding to the physical location of 3 specific RAM chips on the video board. The locators are displayed in blue, green and red and correspond to the 3 RAMS that generate the vertical white lines. Thus, if any of the white lines overlaps a noise dot, the locator tells which chip generated that dot.

When test 5 is first entered the vertical lines are generated by RAM B5 (blue), D5 (green), and F5 (red). The next set of RAMS is selected by using the detent position of the test switch (return the lever to neutral immediately). The vertical lines appear wider since a second set of lines is drawn adjacent to the first set and the RAM locators change to indicate that B8, D8, and F8, generated the new lines. Again, if these white lines overlap any of the noise dots then the designated RAM chips are the bad guys.

This process of activating the detent switch position can be repeated (a total of 16 times) until the entire image area is covered by white lines. It is a good idea to experiment with this test by removing one of the RAM chips and then finding its location using Video RAM locator.

TEST MODE 6

DIP SWITCHES

Test mode 6 serves the dual purpose of checking the proper operation of the option DIP switches (A & B) and displaying the selected options. When test number 6 is entered with all DIP switches OFF, the DIP switch positions which are numbered will be followed by the word OFF in red. When a switch is turned on, the display will be rewritten with the word ON in green following that switch number.

The best way to verify proper operation of the DIP switches is as follows:

1. Turn all switches OFF.
2. Confirm all 16 OFF is displayed
3. Turn all odd-numbered switches ON
4. Confirm alternating ON-OFF is displayed
5. Turn all remaining switches ON
6. Confirm all 16 ON is displayed
7. Turn all odd-numbered switches OFF
8. Confirm alternating OFF-ON is displayed
9. Turn all switches OFF
10. Confirm return to all 16 OFF displayed

The switches should be used to select the various options and the display should confirm the selected options.

TEST MODE 7

COIN & START SWITCHES

Test Mode 7 as in test 6, the switches are numbered and followed by the word OFF (in red) which changes to ON (in green) when a switch is activated. In this display there is an additional column labeled LOCATOR, which provides information concerning the harness connection for each switch. For example, the SLAM switch locator is A30J1-4 which means that this switch is wired to PIN 4 connector J1 on assembly A30 (which is the Peripheral interface board). The common for all switches connected to J1 is on PIN 1 (A30J1-1). When the SLAM switch is activated the display should show COIN-DOOR switch number 3 ON. If it doesn't, connect a jumper between A30J1-1 and 4. If the display shows ON the problem is eternal to the computer system, and if not then the problem is within the electronics. It is very important for the diagnostician to isolate problems in this manner before attempting repairs.

Each of the switches listed in the test mode 7 display should be manually activated to verify proper electrical connections. However, it is important to note that most of these are critical switches and the only way to verify total operational performance is by actual use in a game environment. For example, multiple coins should be inserted in the coin-slot with verification of proper tracking of the coins all the way to the cash box, proper credit accumulation and coin counting.

The SELECT TEST switch cannot be directly tested in this mode since its activation will sequence to test mode 8.

TEST MODE 8

PLAYER SWITCHES

The display format for test mode 8 is identical to number 7 except that it displays the player 1 & 2 control switches connected to A30J3 & J4. The upright version of Killer Comet has one common set of controls connected to A30J3. As in test 7, this test should be used to isolate problems but performance testing must be obtained by operating the switches while playing an actual game.

This test display should be used for fine tuning of joystick control switches. By observing the display while slowly rotating the joystick, improper sequencing of the 4 switches will be obvious. Figure 8 illustrates proper switching. Again, a final test within an actual game is most important to insure proper "feel" of the control.

TEST MODE 9

AUDIO COMPUTER

When test mode 9 is first entered the display lists the 13 sounds that are used in the Killer Comet game. The detent-position of the test switch is used to sequence within this test and generate the variety of sound effects. Some of the sounds generated during tests are quite different from the effect heard during game play so the user should experiment with a "known-good" system to gain familiarity with this test.

The most important part of test mode 9 is displayed in the second column labeled HS for HANDSHAKE. When a sound request is made by the Game Computer, the Audio Computer responds to this request with a "handshake" or "data-taken" signal. If the proper response is received by the Game Computer the test display will write OK (in green) after that sound number. If not, it will write NO (in red). Either response (OK or NO) indicates that the request was made. Thus this test mode provides a check on the Game-to-Audio Computer link when the sound system is not connected or is not working properly.

Sound number 0 does not generate an audio effect. In fact, if any sound is heard then its not working properly since its function is to turn all audio channels off. More important, sound 0 is a forced reset generated by the game computer to insure initialization of the Audio Computer hard-ware and software. During normal play, the game computer program forces resets to insure that the audio does not get locked into a glitch condition.

NOTE: Exit from the test modes is done thru the activation of either coin door switches, the slam switch, or an interruption of power.

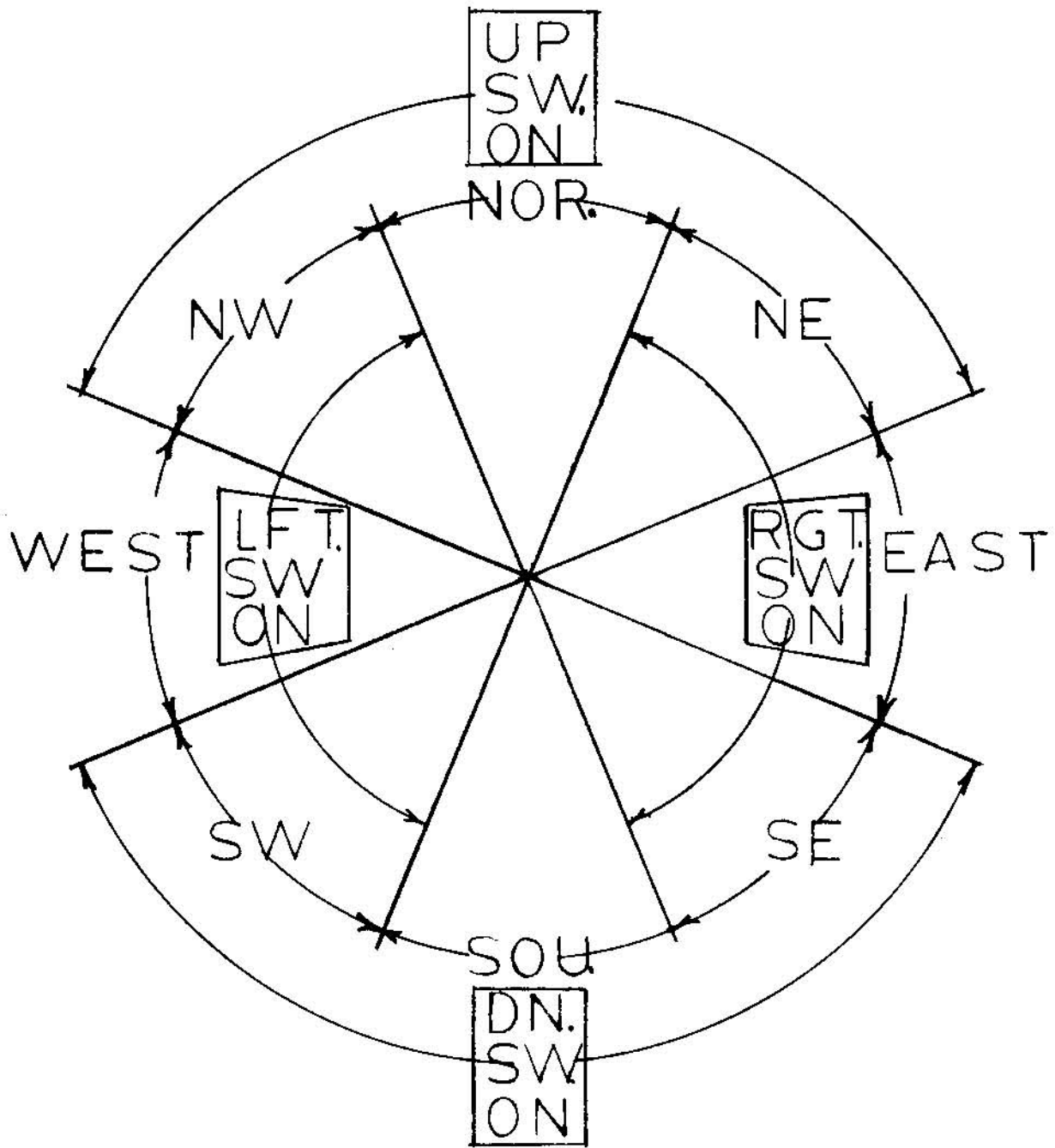

JOYSTICK SWITCH ADJ.

FIG 8

5.0 OPERATOR OPTIONS

Diagnostic test mode 6 is used to display and test the operator-option DIP switches. Most of the information presented in this section is displayed on the monitor as the DIP switches are turned on and off, so the operator can verify his selected program or he can use the display as a reminder of the available options. In addition, the selected credit-option is displayed during the attract mode and the operator should verify that the option displayed is in fact, the one desired.

There are three 8-position DIP switches, labeled A,B, and C, on the Game Computer circuit board. Switches A and B, located at position A5 and B5 on the board, are the option switches. Switch C is reserved for special hardware test and should always be left with all switches off.

The DIP switches are always mounted on the board so that they number 1-8, left to right, and the on-position corresponds to the upward-position.

The standard options for Killer Comet are:

<u>Switch</u>	<u>Function</u>
A-1	Credit Option
A-2	Credit Option
A-4	No. of Turns
A-7	Reaction Time
A-8	Reaction Time
B-7	Monitor Options
B-8	Monitor Options
A-3,A-5,A-6,B1-6	Spare

The standard credit options are:

<u>A-1</u>	<u>A-2</u>	<u>1-Player</u>	<u>2-Player</u>
OFF	OFF	1CREDIT	2 CREDITS
ON	OFF	2CREDITS	3 CREDITS
OFF	ON	2CREDITS	4 CREDITS
ON	ON	FREE PLAY	

The number-of-turns (spacepods) options are:

<u>A-4</u>	
OFF	5 Spacepods per game
ON	4 Spacepods per game

The reaction-time options are:

<u>A-7</u>	<u>A-8</u>	<u>Reaction</u>
OFF	OFF	Slowest
ON	OFF	Slow
OFF	ON	Fast
ON	ON	Fastest

5.0 OPERATOR OPTIONS: CON'T

This reaction-time controls the rate at which the spacepod accelerates and decelerates when the player operates his joystick. Some locations may prefer a faster response and therefore this option has been made available.

All of the DIP switch A options have been programed so that the factory-recommended settings correspond to all switches OFF.

The monitor options are not normally an operator-option since they relate to the game-cabinet configuration..

The Killer Comet Monitor options are:

<u>B-7</u>	<u>B-8</u>	<u>Configuration</u>
OFF		Normal Monitor
ON		Inverted Monitor
	OFF	Upright Cabinet
	ON	Cocktail Cabinet

A little experimentation with your game will clarify the impact of these options. After changing switch settings, the game must go through a complete attract-mode cycle, or the SLAM switch must be activated, to insure that the new parameters are properly set-up in the computer.

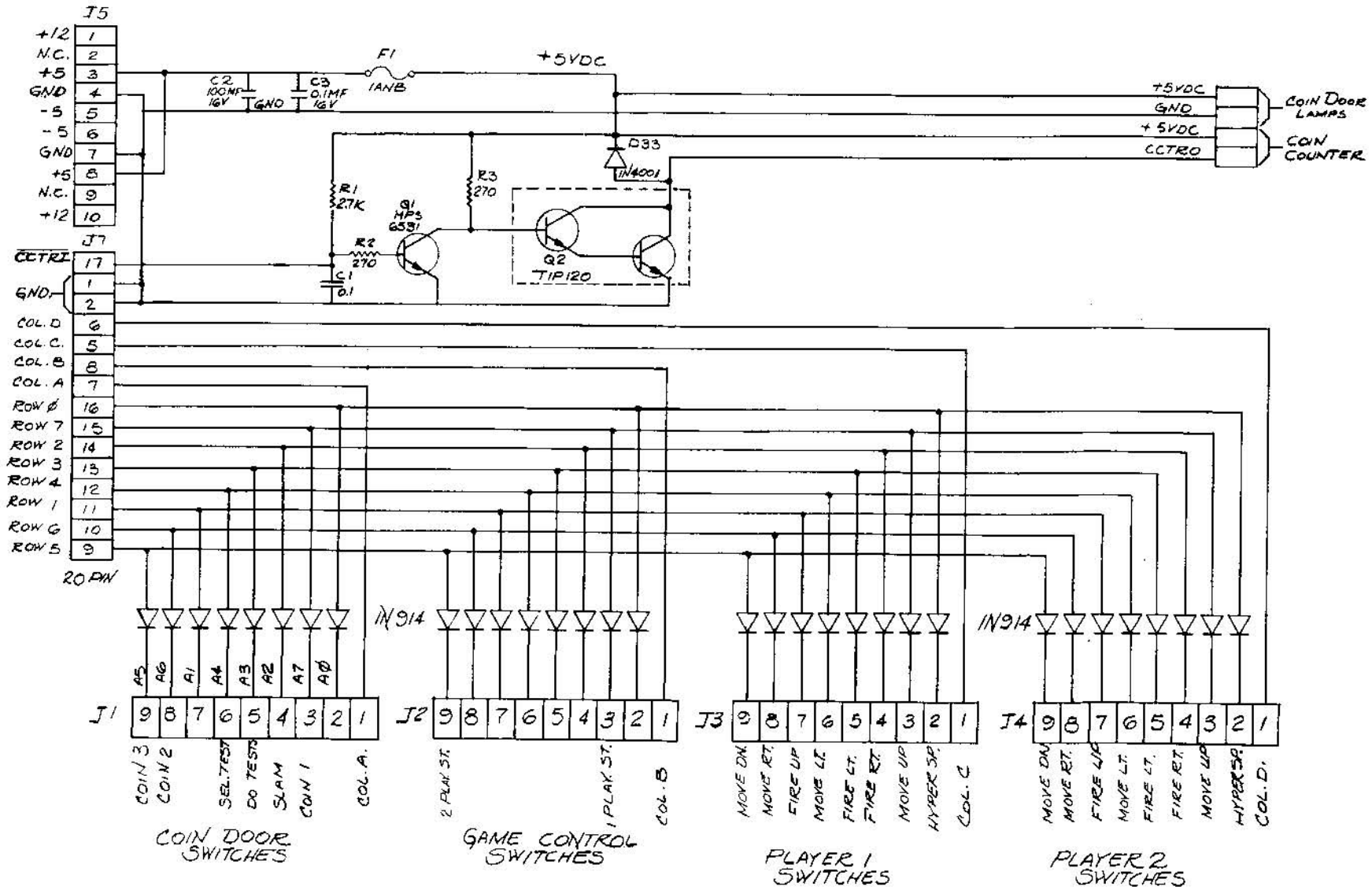

NOTE:
ON UPRIGHT GAME, PLAYER 1 & 2 SWITCHES ARE COMMON
AND ARE BOTH WIRED TO J3 -
J4 USED ON COCKTAIL TABLE ONLY.

Use Only KILLER GAMES		GAME PLAN Inc 1515 W. Fullerton Ave Addison, ILL. 60101	
PARTS MUST BE CLEAN AND FREE OF BURRS		Scale	Finish
Tolerances Unless Specified		Date 2/11/83	App By
Fractional	± .015	Mat'l	Drawing Number
Decimal	± .002		02-70061C
Angles	± 1/2		PERIPHERAL INTERFACE BOARD
Screw Threads	Class 2		
ISSUE	CHANGE	DATE	

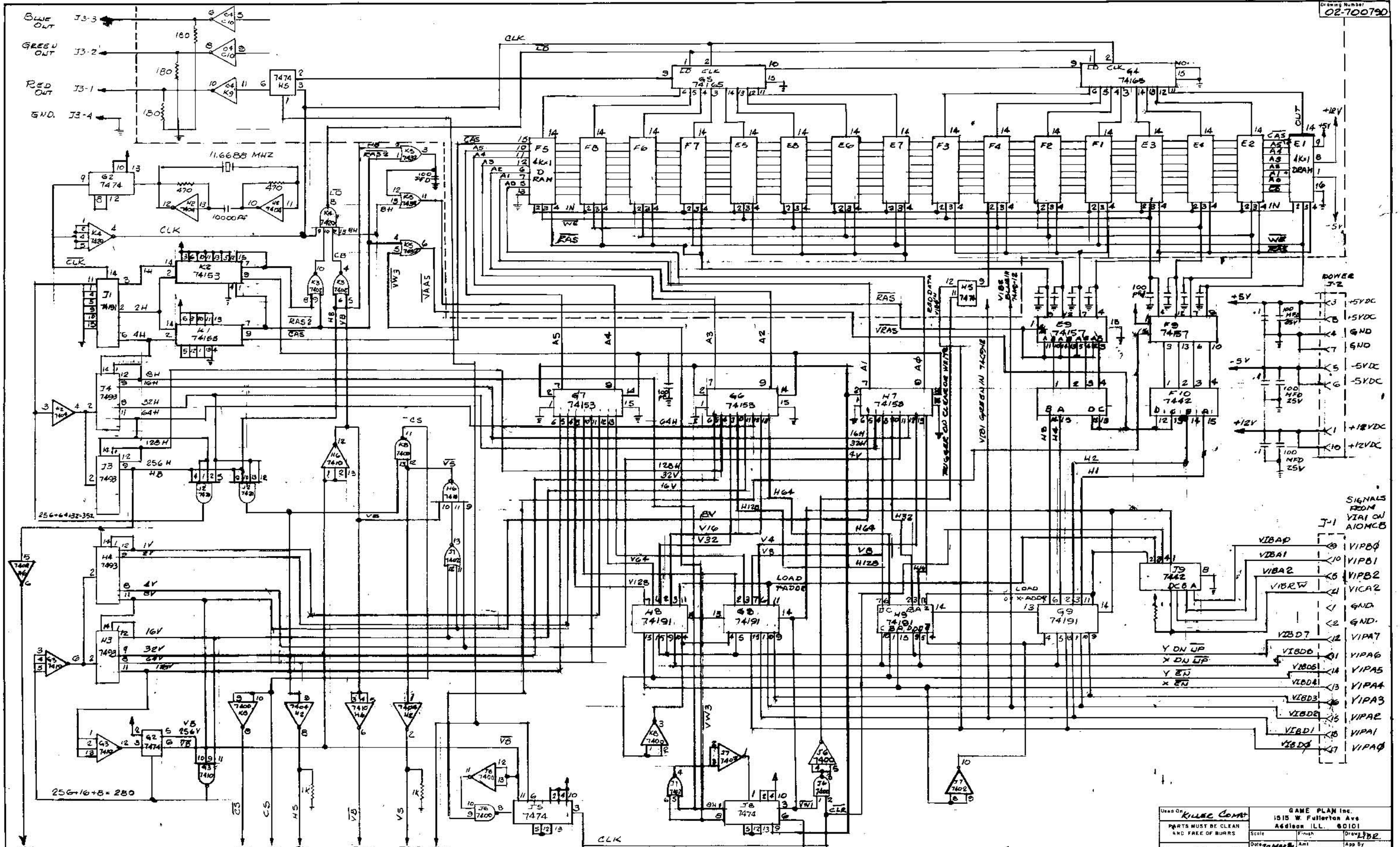

- SIGNALS FROM J-1
- VIBA0
 - VIBA1
 - VIBA2
 - VIBRW
 - VIBD7
 - VIBD6
 - VIBD5
 - VIBD4
 - VIBD3
 - VIBD2
 - VIBD1
 - VIBD0
 - VIPB0
 - VIPB1
 - VIPB2
 - VICAR
 - VIPAT
 - VIPAG
 - VIPAS
 - VIPAA
 - VIPAS
 - VIPAP
 - VIPAP

Used On	KILLER COMBAT	GAME PLAN Inc.
PARTS MUST BE CLEAN AND FREE OF BURRS	Scale	1515 W. Fullerton Ave. Addison, ILL. 60101
Tolerances Unless Specified	Date	02-70079D
Fractional	Drawn	02-70079D
Decimal	App By	VIDEO INTERFACE BOARD SCHEMATIC
Angles	Issue	
Screen Threads	Change	
	Date	

J1-3 HORIZ BLANK VIPB6
 J3-1 RED OUT
 J3-2 GREEN OUT
 J3-3 BLUE OUT
 J3-4 GND
 J-2 POWER
 J-2 +5VDC
 J-2 -5VDC
 J-2 +12VDC
 J-2 -12VDC

J1-4 WRITE-DELAY VIPB7

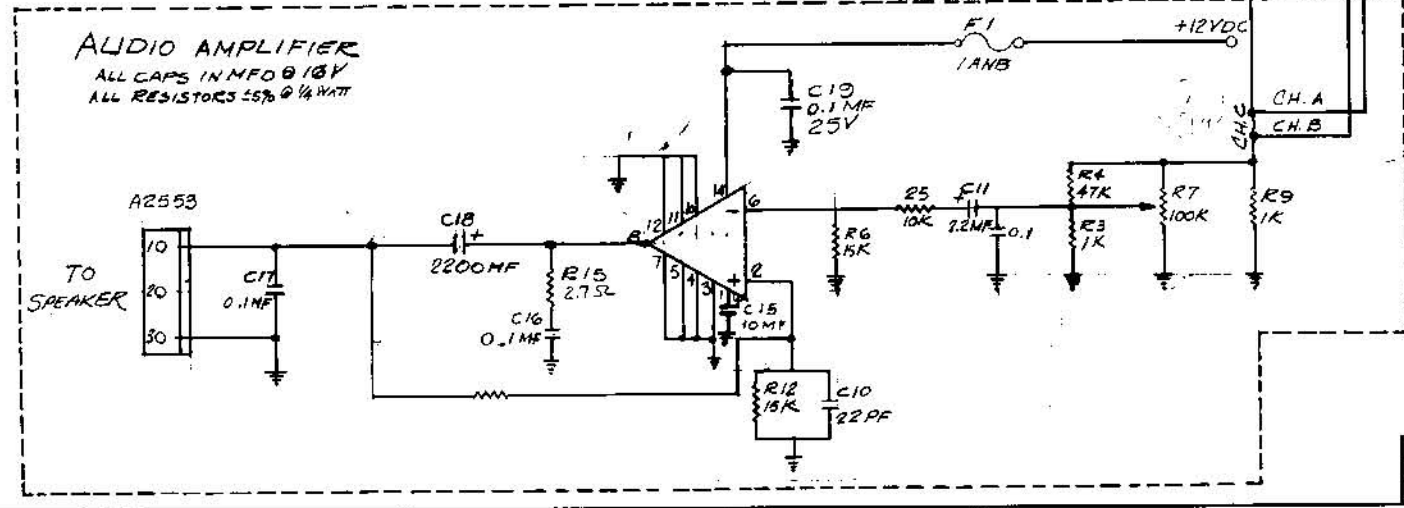
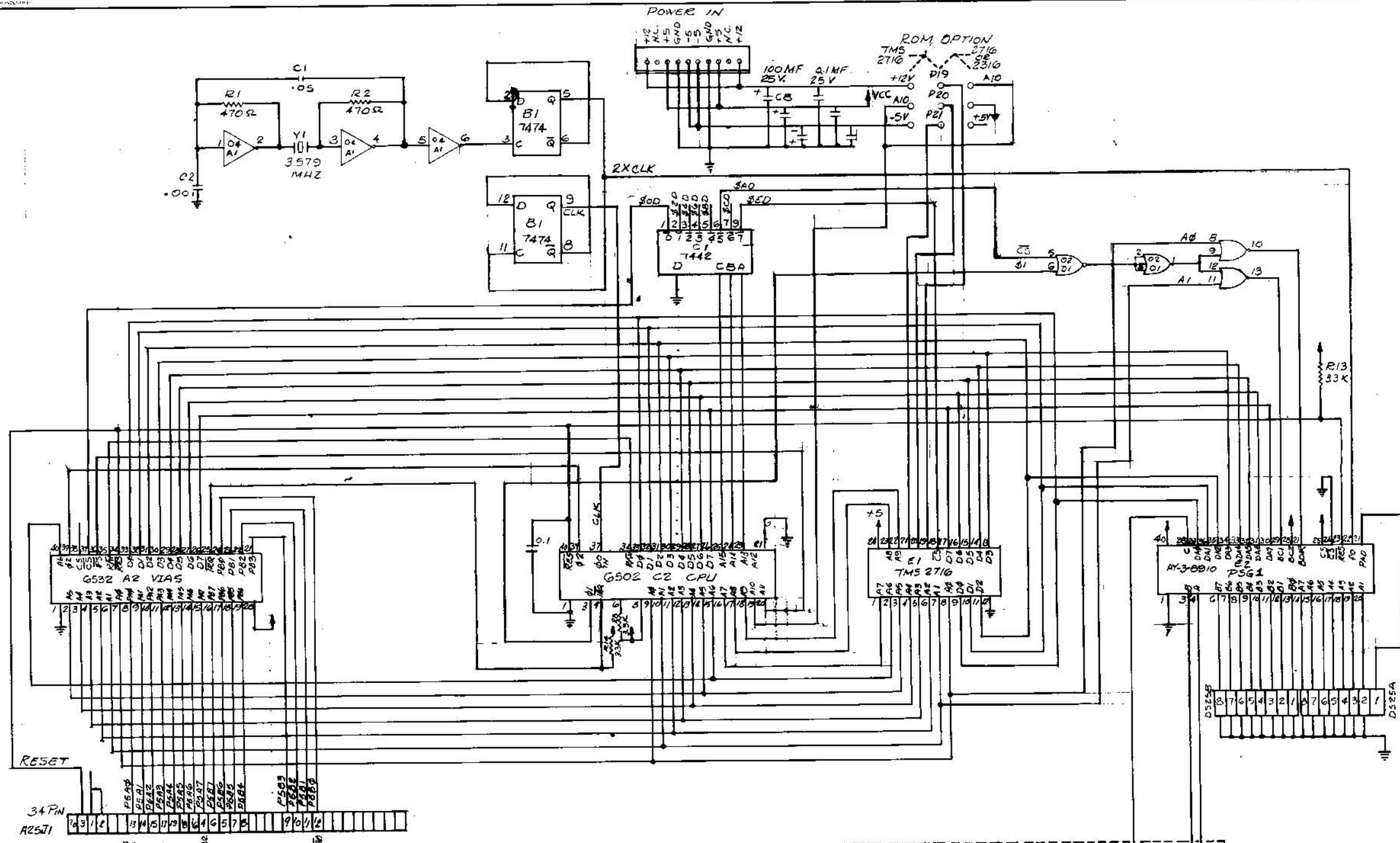

ISSUE	CHANGE	DATE

Used On	KILLER COMET		
PARTS MUST BE CLEAN AND FREE OF BURRS	Scale	Finish	Drawn By
Tolerances Unless Specified	Date 25 MAR 81	App. By	
Fractional	± .015	Drawing Number	02-700800
Decimal	± .005	AUDIO COMPUTER BOARD	
Angles	± 1/2	INCL AUDIO AMP.IFIER	
Screw Threads	Class 2		

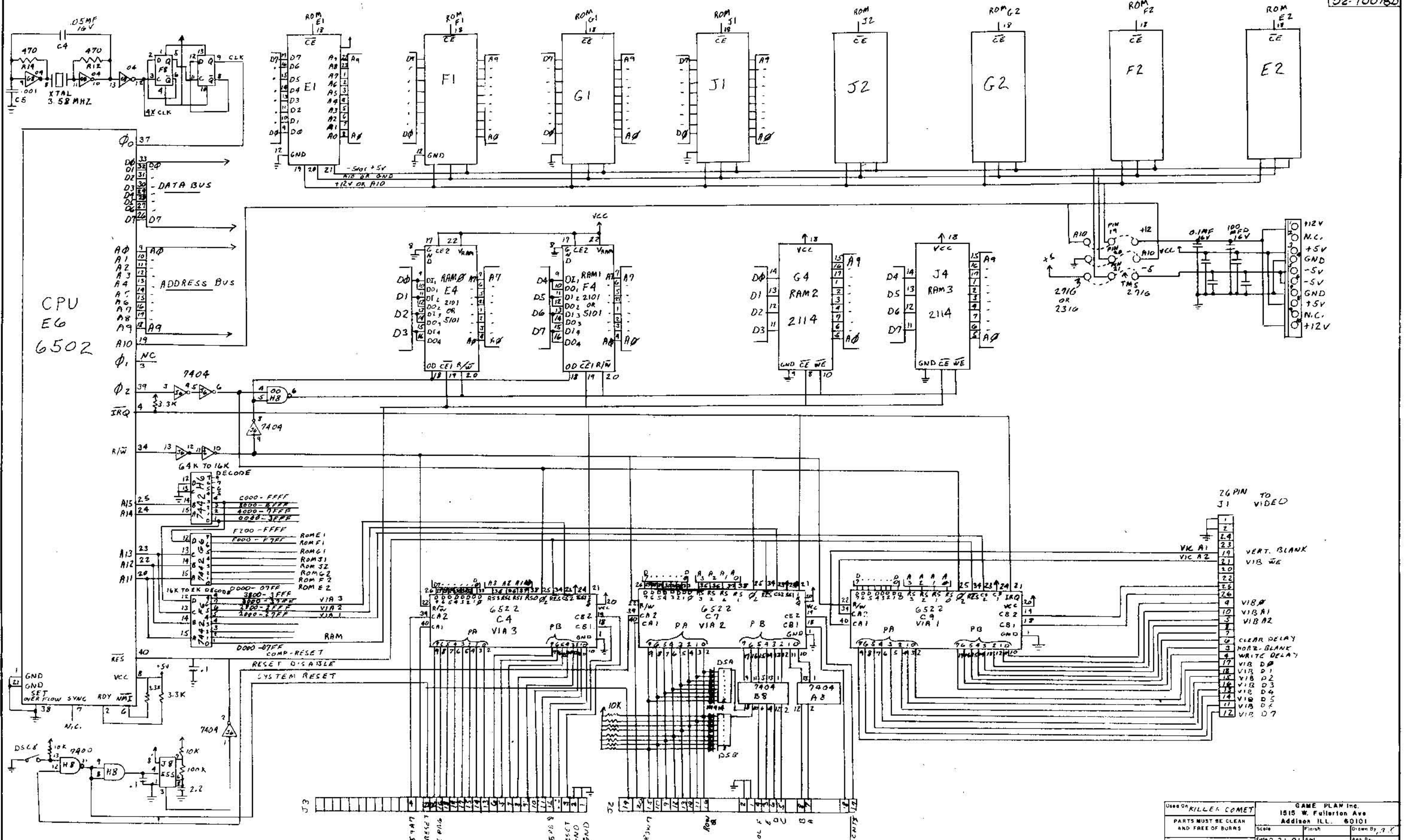

CPU
EG
6502

Use on KILLER COMET		GAME PLAN Inc. 1515 W. Fullerton Ave Addison ILL. 60101	
PARTS MUST BE CLEAN AND FREE OF BURRS		Scale	Finish
Tolerances Unless Specified		Drawn By	App By
Fractional	± .015	02-70078D	
Decimal	± .005	COMPUTER BOARD	
Angles	± 1/2		
Screw Threads	Class 2		

ISSUE	CHANGE	DATE