

**Lil'
Hustler**

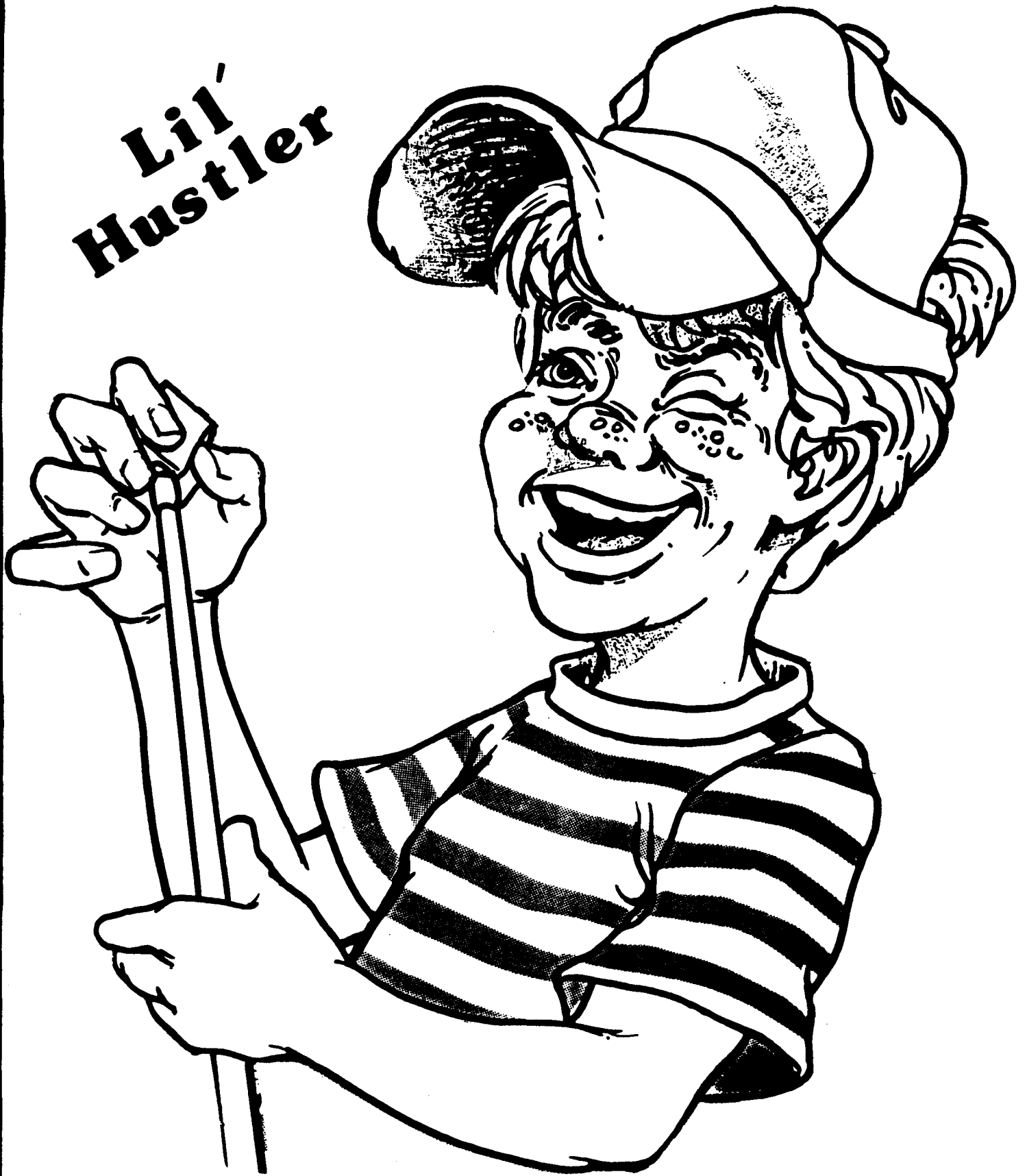

Service Manual No. 92-008

Lil' Hustler

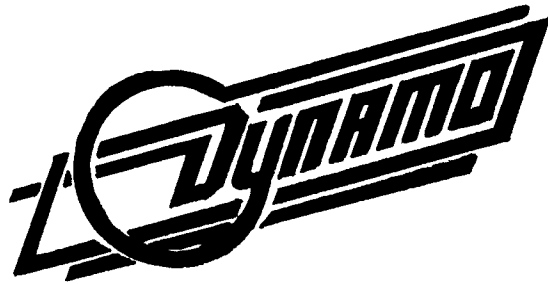

DYNAMO CORPORATION
1805 S. Great Southwest Pkwy.
Grand Prairie, TX. 75051
Telephone: (214) 641-4286

CUSTOMER SERVICE:

Telephone: (214) 641-4286 (In Texas)
Telephone: (800) 527-6054 (Outside Texas)

TABLE OF CONTENTS

PAGE NO.

I. INTRODUCTION:
F.C.C. USER INFORMATION.....1
GAME SUMMARY.....2

II. SPECIFICATIONS:
INSTALLATION.....3
ELECTRICAL REQUIREMENTS.....3
POWER SUPPLY.....3

III. OPERATION:
GAME INSTRUCTIONS.....4
GAME POINT SCORING.....4
ROUTINE MAINTENANCE & SERVICE.....5
TROUBLE SHOOTING.....5
TROUBLE SHOOTING DIAGRAM (FIGURE 4).....6
OPERATOR ADJUSTMENTS.....7
OPTIONAL SWITCH SETTINGS.....7
SWITCH SETTINGS.....7

IV. GENERAL:
CABINET DIAGRAM (FIGURE 1).....8
PARTS LIST - CABINET DIAGRAM (FIGURE 1).....9
CABINET CROSS SECTION (FIGURE 2).....10
PARTS LIST - CABINET CROSS SECTION (FIGURE 2).....11
CONTROL PANEL - EXPLODED VIEW (FIGURE 3).....12
PARTS LIST - CONTROL PANEL - EXPLODED VIEW (FIGURE 3).....13
PARTS LIST - SHINDENGEN POWER SUPPLY.....14, 15
MONITOR SERVICE INFORMATION.....16-22

V. DRAWINGS & SCHEMATICS:
POWER SUPPLY SCHEMATIC.....23
LOGIC CABLE SCHEMATIC.....24
SEMICONDUCTOR LOCATION - MAIN BOARD.....25
SEMICONDUCTOR LOCATION - SUB BOARD.....26
19" COLOR MONITOR SCHEMATIC.....27
MAIN LOGIC BOARD SCHEMATIC.....28
SUB LOGIC BOARD SCHEMATIC.....29

F.C.C. USER INFORMATION

WARNING:

THIS EQUIPMENT GENERATES, USES AND CAN RADIATE RADIO FREQUENCY ENERGY AND IF NOT INSTALLED AND USED IN ACCORDANCE WITH THE INSTRUCTIONS MANUAL, MAY CAUSE INTERFERENCE TO RADIO COMMUNICATIONS. AS TEMPORARILY PERMITTED BY REGULATION, IT HAS NOT BEEN TESTED FOR COMPLIANCE PURSUANT TO SUBPART J OF PART 15 OF F.C.C. RULES, WHICH ARE DESIGNED TO PROVIDE REASONABLE PROTECTION AGAINST SUCH INTERFERENCE. OPERATION OF THIS EQUIPMENT IN A RESIDENTIAL AREA IS LIKELY TO CAUSE INTERFERENCE IN WHICH CASE THE USER AT HIS OWN EXPENSE WILL BE REQUIRED TO TAKE WHATEVER MEASURES MAY BE REQUIRED TO CORRECT THE INTERFERENCE.

GAME SUMMARY

DYNAMO CORPORATION is proud to announce it's first video game, "Lil' Hustler", with the latest advances in microcomputer and graphic display technology.

"Lil' Hustler" is a totally new game concept, developed to challenge the skill of even the most adept video game player, as well as the expert pool and billiard player.

The ball action will fascinate every player, both visually and audibly. "Lil' Hustler" is the first video game with cushion action, ball rebound, and cue ball control.

As the cue ball breaks the racked balls, the balls dramatically respond. Experienced pool players will be fascinated at the shots they can make with the intricate cue ball control.

Button controls move the target dot around the "cushion". When the "shoot" button is pressed, the cue ball moves towards the target dot, and will hit any object ball in it's path. With practice, the player can develop sophisticated game techniques.

Speed bars are built into the game program, to enable the player to use different forces of stroke on the cue ball.

Other features include extra shots in given time periods, bonus points if object balls are sunk in six shots, and double score if two object balls are pocketed in one shot. A bonus cue ball is awarded when player score is at 10,000 points.

To add challenge to the game, pocket scores rotate in patterns around the cushion.

Game is over when the player has pocketed all his cue balls.

INSTALLATION

Your game was shipped from the factory in ready-to-play condition. A brief inspection is suggested before the machine is removed from the carton. If there is damage to the shipping carton, contact the freight carrier for claim purposes. External damage could indicate possible damage to the cabinet and/or electronic components.

After the carton has been satisfactorily inspected, remove the machine from the shipping carton.

Examine the interior of the game for disconnected wires, cables, or harnesses. Make sure the electronic (CPU, EPROM, etc.,) devices are securely mounted in their sockets, etc. Record the game serial number since it will be required for reference and servicing.

ELECTRICAL REQUIREMENTS

Unless otherwise specified, this game is set to operate at 110 Volts A.C.

Power supply chassis schematic information and parts list are included in this manual.

POWER SUPPLY



For most efficient operation of this game, the power supply should be set so that the voltage on the board is + 5.0 Volts, \pm 0.1 Volts. To check this, place a meter across +5.0 Volts and ground at the edge connector. If necessary, adjust the screwdriver control on the power supply so the meter reads between 4.9 and 5.1 Volts.

"LIL HUSTLER"

GAME INSTRUCTIONS

1. INSERT COIN(S).
2. PRESS ONE OR TWO PLAYER BUTTON.
3. USE LEFT OR RIGHT BUTTONS TO MOVE TARGET DOT AROUND "CUSHION".
4. WHEN SHOOT BUTTON IS PRESSED, CUE BALL WILL MOVE TOWARDS TARGET DOT, AND HIT ANY OBJECT BALL IN IT'S PATH.
5. "SPEED BARS" INDICATE FORCE OF STROKE ON CUE BALL.
 ■ = SOFT, ■■ = MEDIUM, ■■■ = HARD.
6. "REST" TIME APPEARS AS "DIAMONDS". IF THREE SHOTS ARE MADE WITHIN THIS TIME, THREE EXTRA SHOTS ARE ALLOWED. (ONLY TWO SHOTS IN FOURTH AND HIGHER FRAMES).
7. BONUS POINTS ARE AWARDED IF ALL OBJECT BALLS ARE SUNK IN SIX SHOTS.
8. DOUBLE SCORE IF TWO OBJECT BALLS ARE SUNK IN ONE SHOT.
9. BONUS EXTRA CUE BALL AT 10,000 POINTS.

10. SCORING:

BALL NUMBER	(TIMES)	POCKET VALUE	(TIMES)	FRAME (PATTERN) NUMBER	EQUALS POINTS.
	x		x	(Pattern 2) FRAME	= 40 Points.

GAME POINT SCORING

The scoring for this game is calculated as follows:
 When a ball is sunk, the number on the ball is multiplied by the pocket value, times the pattern number (frame). The end number is the score for that pattern, which is added to the existing score, giving a game total point value.

ROUTINE MAINTENANCE & SERVICE

Because of the solid state electronic circuitry, this equipment should require very little maintenance and only occasional adjustments. However, it is necessary to take measures to insure this.

TROUBLESHOOTING:

If the game is not functioning properly, check the following items:

1. Is the fuse intact? (Always use fuse of the designated rating). If the replaced fuse opens again, this indicates another component is defective.
2. Are there any poor connections (connectors) or open circuits? Special care must be taken to ensure connectors are firmly inserted. Problems due to faulty contacts can exhibit various symptoms.
NOTE: Always turn off the power when inserting or removing the connectors.
3. If a normal picture does not appear when the power switch is on, reset of the control circuit may be necessary. Check this by turning the power supply switch on and off several times.
4. When checking counters, switches, etc. with a tester, always disconnect the I.C. Board edge connector first.

The video monitor has been properly adjusted before shipping. Occasionally minor adjustments are necessary. See monitor specifications and schematics for technical information. Adjustment controls for the monitor are located at the rear of the monitor.

This machine should be serviced only by a qualified technician.

Do not make any adjustments on this machine while the power is on.

For service information, contact:

DYNAMO CORPORATION
Customer Service Department
#(214) 641-4286 (In Texas)
#(800) 527-6054 (Outside Texas)

TROUBLE SHOOTING

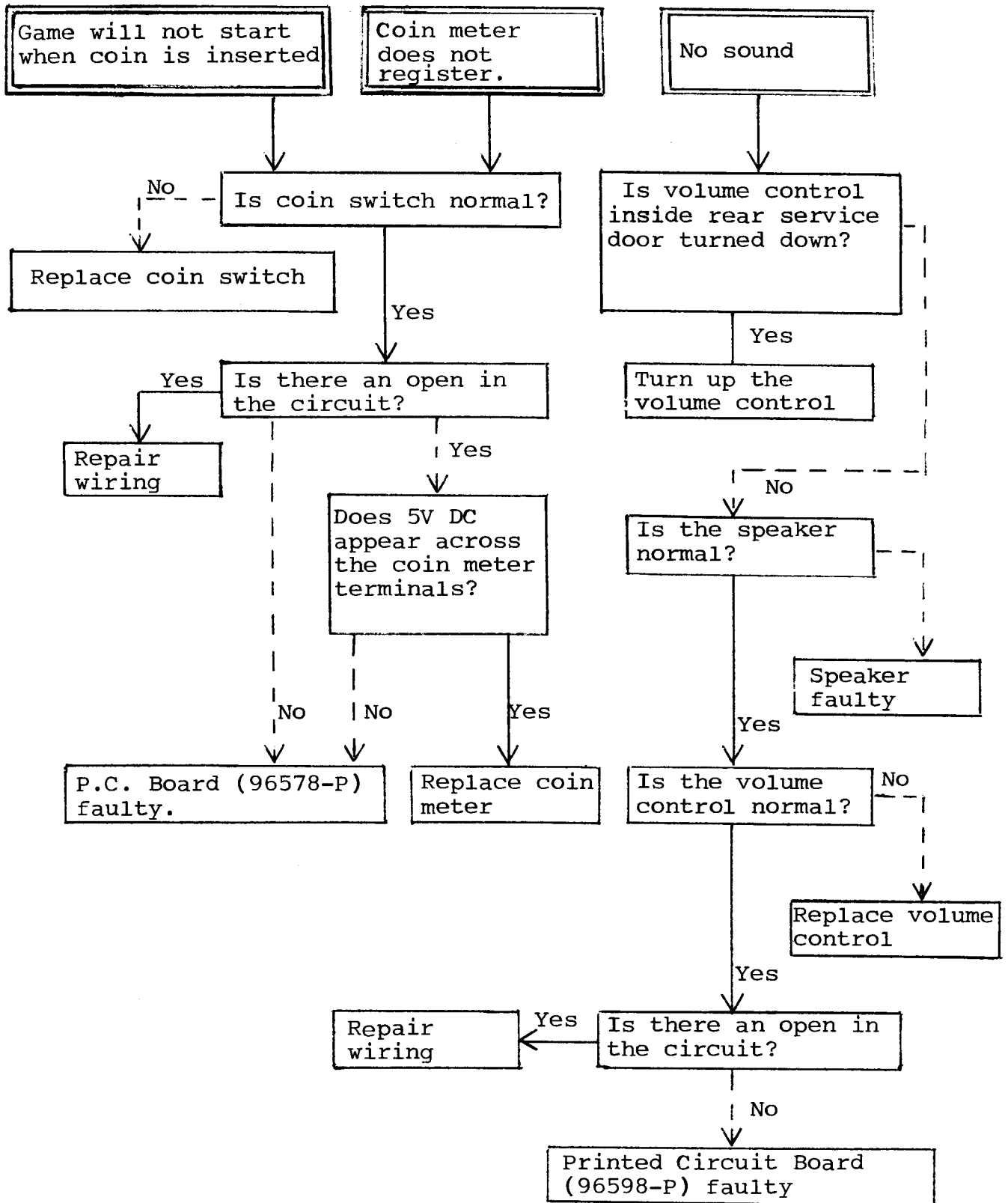

(FIGURE 4)

OPERATOR ADJUSTMENTS

OPTIONAL SWITCH SETTINGS

The option switches are located on the logic board. The OPTION SWITCHES and AUDIO VOLUME CONTROL can be reached through the back of the cabinet.

SWITCH SETTINGS

	<u>SW-1</u>	<u>SW-2</u>
ONE CUE BALL PER COIN	ON	ON
TWO CUE BALLS PER COIN	ON	OFF
THREE CUE BALLS PER COIN	OFF	ON
∞	OFF	OFF

	<u>SW-3</u>
UPRIGHT GAME	ON
TABLE GAME	OFF

	<u>SW-4</u>	<u>SW-5</u>
ONE COIN - ONE PLAY	ON	ON
TWO COINS - ONE PLAY	ON	OFF
THREE COINS - ONE PLAY	OFF	ON
ONE COIN - TWO PLAYS	OFF	OFF

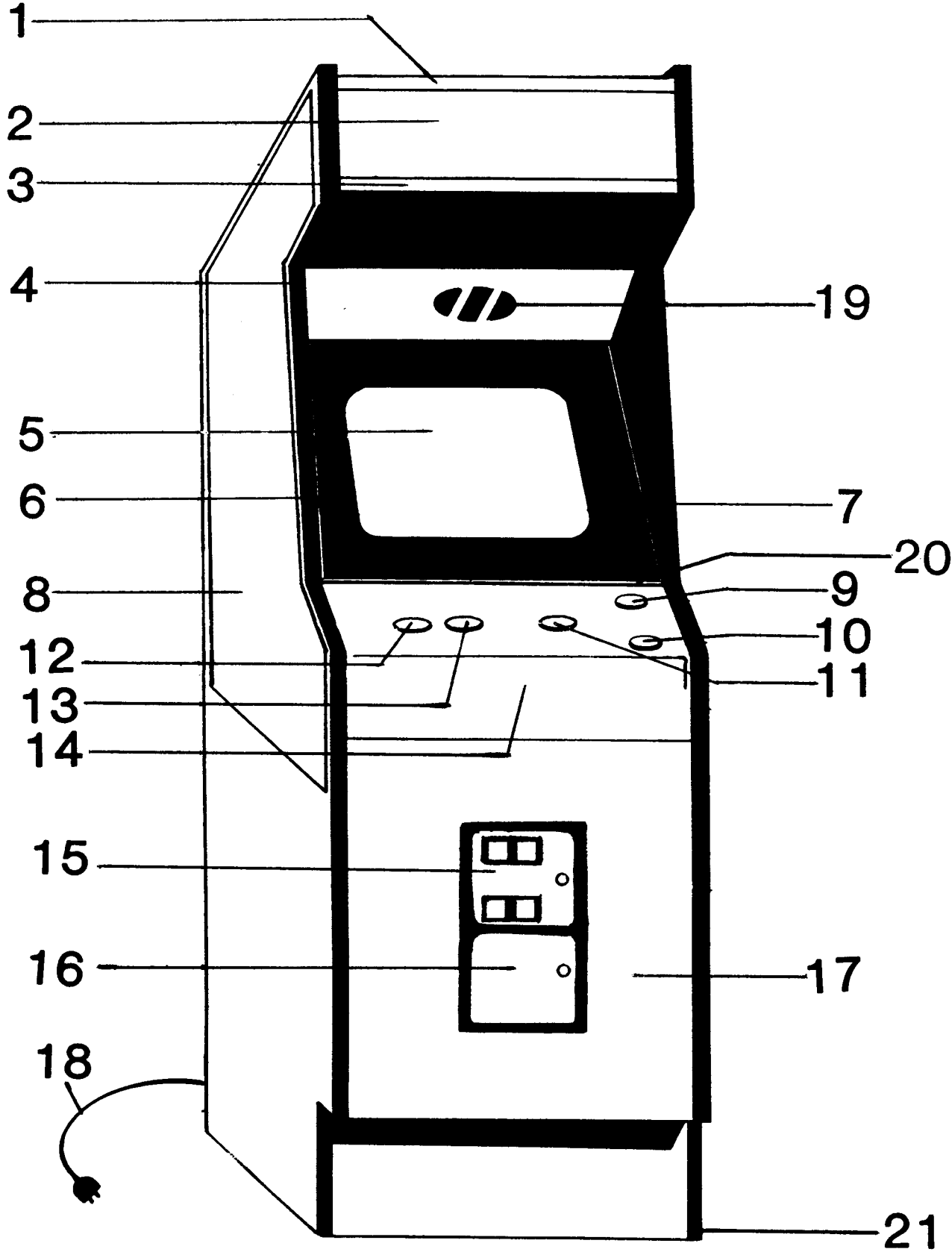

(FIG.1) CABINET

PARTS LIST - CABINET (FIG. 1)

<u>NO:</u>	<u>PART NO:</u>	<u>DESCRIPTION:</u>
1	93-006	HEADER TOP MOUNTING BRACKET
2	92-004	SILK SCREENED HEADER
3	93-005	HEADER BOTTOM MOUNTING BRACKET
4	92-005	VINYL TRIM
5	92-001	VIEWING GLASS
6	92-001	SILK SCREENED MONITOR OVERLAY
7	92-002	RIGHT HAND SIDE DECAL
8	92-002-A	LEFT HAND SIDE DECAL
9	91-050	ONE-PLAYER START BUTTON
10	91-050-A	TWO-PLAYER START BUTTON
11	91-051	SHOOT BUTTON
12	91-050-B	LEFT MOVEMENT BUTTON
13	91-050-C	RIGHT MOVEMENT BUTTON
14	93-003	CONTROL PANEL WIRED ASSEMBLY
15	91-002	COIN DOOR ASSEMBLY
16	91-003	CASH BOX
17	90-500	WOOD CABINET ASSEMBLY
18	91-058	A.C. LINE CORD HARNESS
19	93-007	SPEAKER SCREEN
20	93-004	VIEWING GLASS BRACE BRACKET
21	93-001	LEG LEVELER (4)

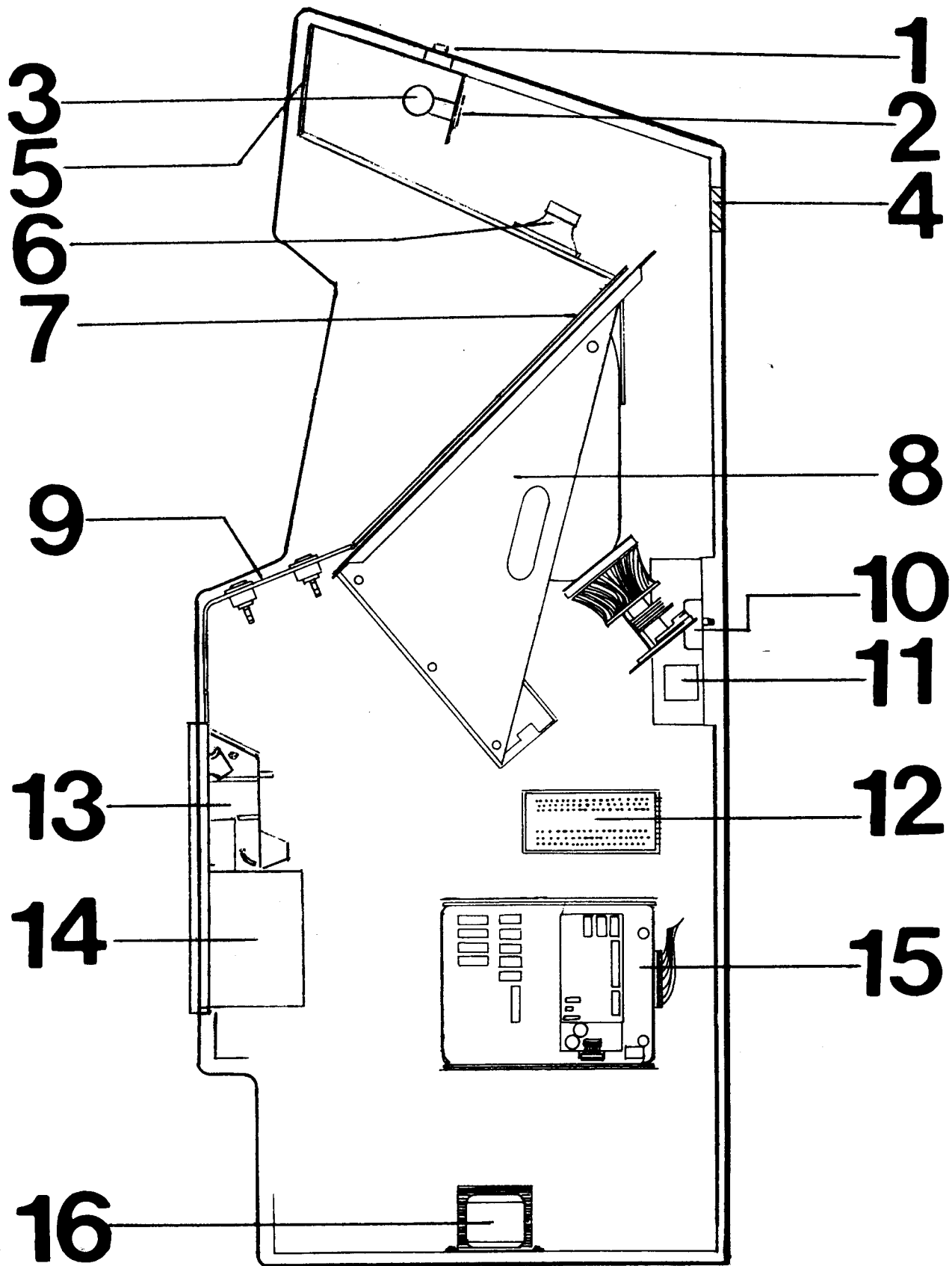

(FIG.2) CABINET CROSSECTION.

PARTS LIST - CABINET CROSS SECTION (FIG. 2)

<u>NO:</u>	<u>PART NO:</u>	<u>DESCRIPTION:</u>
1	91-062	POWER SWITCH ASSEMBLY
2	93-014	INCANDESCENT LAMP ASSEMBLY
3	91-061	INCANDESCENT LAMP - 25 WATTS
4	93-008	VENT
5	92-004	HEADER - PLEXIGLASS
6	91-006	SPEAKER, 5" ROUND, 8 WATT, 8 OHM
7	92-001	VIEWING GLASS
8	91-001	19" COLOR MONITOR ASSEMBLY
9	93-003	CONTROL PANEL ASSEMBLY - WIRED
10	91-057	INTERLOCK SWITCH
11	91-056	LINE FILTER
12	91-004	POWER SUPPLY, SWITCHING REGULATOR
13	91-002	COIN DOOR ASSEMBLY
14	91-003	CASH BOX ASSEMBLY
15	91-008	PRINTED CIRCUIT BOARD ASSEMBLY
16	91-005	ISOLATION TRANSFORMER WIRED ASSEMBLY

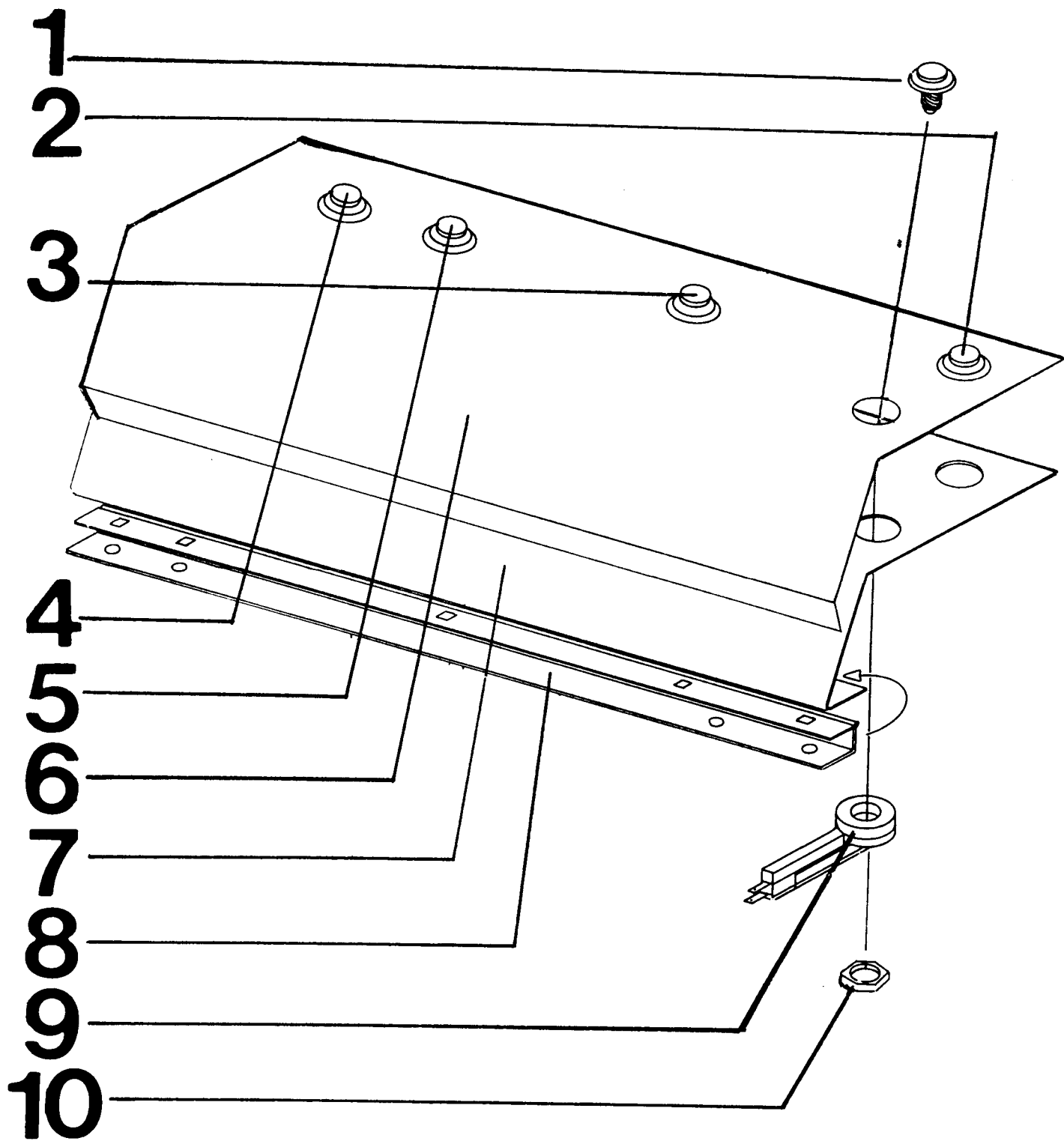

(FIG.3) EXPLODED VIEW OF CONTROL PANEL.

PARTS LIST - CONTROL PANEL (FIG. 3)

<u>NO:</u>	<u>PART NO:</u>	<u>DESCRIPTION:</u>
1	91-050-A	TWO-PLAYER BUTTON
2	91-050	ONE-PLAYER BUTTON
3	91-051	SHOOT BUTTON
4	91-050-B	LEFT BUTTON
5	91-050-C	RIGHT BUTTON
6	92-003	CONTROL PANEL OVERLAY
7	93-003	CONTROL PANEL (SHEET METAL)
8	93-011	CONTROL PANEL HINGE
9	91-052	BUTTON SWITCH ASSEMBLY
10	91-053	PAL NUT

PARTS LIST - SHINDENGEN POWER SUPPLY

<u>SYMBOL:</u>	<u>DESCRIPTION:</u>	<u>USAGE:</u>
T1	TRANSFORMER, SINGLE PHASE, 2A VA	1
L1	Choking Coil, 1.6 mH, 1.5A	1
L2, L4	Choking Coil, SF-T8-50S-03	2
L3	Choking Coil, SF-HP-2A-03	1
D1	Diode, V19G	1
D2	Diode, V06C	1
D3, D6	Diode, 1S1588	2
D4	Diode, S15S3	1
D5, D7	Diode, 5SH1M	2
D12, D13	Diode, F113B	2
D14	Diode, F113B	1
RF1	Diode, S4VB40 (Bridge Type)	1
Q1	Transistor, 2SC2504	1
Q2	Transistor, 2SD467 (B)	1
Q3	Transistor, 2SC460 (B)	1
Q4	Transistor, 2SA673 (B)	1
IC1	Integrated Circuit, RM723DC or HA17723G-02	1
PC1	Photo Coupler, PS2001	1
R1	Resistor, 2 Watt, 18 Ohm	1
R8, R9	Resistor, 2 Watt, 47K Ohm	2
R3, 1-4	Resistor, 2 Watt, 15 Ohm	4
R4	Resistor, 1 Watt, 56 Ohm	1
R12	Resistor, 1 Watt, 100 Ohm	1
R28	Resistor, 1 Watt, 470 Ohm	1
R7	Resistor, 1 Watt, 0.56 Ohm	1
R26	Resistor, 1 Watt, 0.82 Ohm	1
R23	Resistor, 1/4 Watt, 22 Ohm	1
R10	Resistor, 1/4 Watt, 33 Ohm	1
R27	Resistor, 1/4 Watt, 68 Ohm	1
R2	Resistor, 1/4 Watt, 330-470 Ohm	1
R22	Resistor, 1/4 Watt, 220 Ohm	1
R21	Resistor, 1/4 Watt, 270 Ohm	1
R6	Resistor, 1/4 Watt, 330 Ohm	1
R11	Resistor, 1/4 Watt, 68 Ohm	1
R20	Resistor, 1/4 Watt, 470 Ohm	1
R17	Resistor, 1/4 Watt, 680 Ohm	1
R19	Resistor, 1/4 Watt, 800 Ohm	1
R18	Resistor, 1/4 Watt, 1.2K Ohm	1
R5	Resistor, 1/4 Watt, 10K Ohm	1
R16	Resistor, 1/4 Watt, 220K Ohm	1
R29	Resistor, 3 Watt, 27 Ohm	1
R39	Resistor, 1/4 Watt, 4.7K Ohm	1
R38	Resistor, 1/4 Watt, 5.6K Ohm	1
R24	Resistor, 1/4 Watt, 330 Ohm	1
R25	Resistor, 1/4 Watt, 150 Ohm	1
RV1	Variable Resistor, RJ-6P501	1

PARTS LIST - SHINDENGEN POWER SUPPLY

<u>SYMBOL:</u>	<u>DESCRIPTION:</u>	<u>USAGE:</u>
C1, C2	Capacitor, ECK-DAL102E	2
C3-1,-2	Capacitor, 160VSN100	2
C9, C10	Capacitor, SM10VB-2200	2
C11, C23	Capacitor, SM10VB-2200	2
C12,C13,C15	Capacitor, SL25VB-10	3
C27	Capacitor, SL25VB-10	1
C18,C19,C20	Capacitor, SM35VB-1000	3
C26	Capacitor, SM35VB-1000	1
C21,C22,C25	Capacitor, SM16VB-1000	3
C5	Capacitor, DMY21H472K	1
C6	Capacitor, DMY21H	1
C14, C16	Capacitor, DMY21H222K	2
C4	Capacitor, CM20XC511K5	1
C8	Capacitor, MDD22G473K	1
C5-2	Capacitor, DMY21H222K	1
F1, F2	ENCLOSED TYPE FUSE, 3A	2

K4600 IMPORTANT SERVICE SAFETY INFORMATION

WARNING: An isolation transformer must be used between the AC supply and the AC plug of the monitor before servicing or testing is performed since the chassis and the heat-sink are directly connected to one side of the AC line which could present a shock hazard.

The chassis of the monitor should never be connected to the ground. Before servicing is performed, read all the precautions labelled on the CRT and chassis.

X-RAY RADIATION WARNING NOTICE

WARNING: PARTS WHICH INFLUENCE X-RAY RADIATION IN HORIZONTAL DEFLECTION, HIGH VOLTAGE CIRCUITS AND PICTURE TUBE ETC. ARE INDICATED BY (★) IN THE PARTS LIST FOR REPLACEMENT PURPOSES. USE ONLY THE TYPE SHOWN IN THE PARTS LIST.

PRODUCT SAFETY NOTICE

WARNING: FOR CONTINUED SAFETY REPLACE SAFETY CRITICAL COMPONENTS ONLY WITH MANUFACTURER RECOMMENDED PARTS. THESE PARTS ARE IDENTIFIED BY SHADING AND BY (Δ) ON THE SCHEMATIC DIAGRAM.

AVERTISSEMENT: POUR MAINTENIR LE DEGRE DE SECURITE DE L'APPAREIL NE REMPLACER LES COMPOSANTS DONT LE FONCTIONNEMENT EST CRITIQUE POUR LA SECURITE QUE PAR DES PIECES RECOMMANDEES PAR LE FABRICANT.

For replacement purposes, use the same type or specified type of wire and cable, ensuring that the positioning of the wires is followed (especially for H.V. and power supply circuits). Use of alternative wiring or positioning could result in damage to the monitor or in a shock or fire hazard.

The picture tube used, employs integral implosion protection and should be replaced with a tube of the same type number for continued safety.

When handling the CRT, shatter-proof goggles must be worn after completely discharging the high voltage circuit. Do not lift the picture tube by the neck.

PERFORMANCE AND OPERATING DATA

1. Apply a suitable power source to the monitor through an isolation transformer.
2. Apply a suitable signal source to the monitor PCB by means of P205.
3. Set up Controls.
All controls are preset at the factory, but may be adjusted to suit program material.

1.0 Supply

Voltage	108 VAC - 132 VAC
Frequency	50 Hz - 60 Hz

Note: Apply supply voltage through an isolation transformer with 1 Amp. capability.

2.0 High Voltage (EHT)

For 19"V models	25.5 ± 0.8 K.V. at 0 Beam
-----------------	---------------------------

Note: Condition for above 1 (beam) = 0
A.C. = 120V

3. Service Set-Up Controls

- A. V. Adjustment VR501 set for 127V DC
- B. Vertical Size Cont = VR302
- C. Vertical Hold Cont = VR301
- D. Horizontal Hold Cont = VR351
- E. Horizontal Width Cont = L702
- F. Focus Control = VR702

- G. Screen Control = VR406
- H. Video Drive Controls - Red Drive = VR401
Green Drive = VR402
- I. CRT Cut Off Controls - Red Cutoff = VR403
Green Cutoff = VR404
Blue Cutoff = VR405

SERVICE INSTRUCTIONS

FOCUS

Adjust the Focus control (VR702), located on the HV unit (T701), for maximum over-all definition and fine picture detail.

+ 127V ADJUSTMENT (See Fig. 1)

The + 127V adj. control (VR501) is adjusted at the factory. However, if readjustment should be required, proceed as follows.

1. Operate monitor for at least 15 minutes at 120V AC line.
2. Connect Positive lead of V.T.V.M. to blue lead of TR502 emitter negative lead to chassis ground.
3. Adjust VR501 to obtain + 127V reading.
4. After adjustment VR501 must be locked with a sealing varnish.

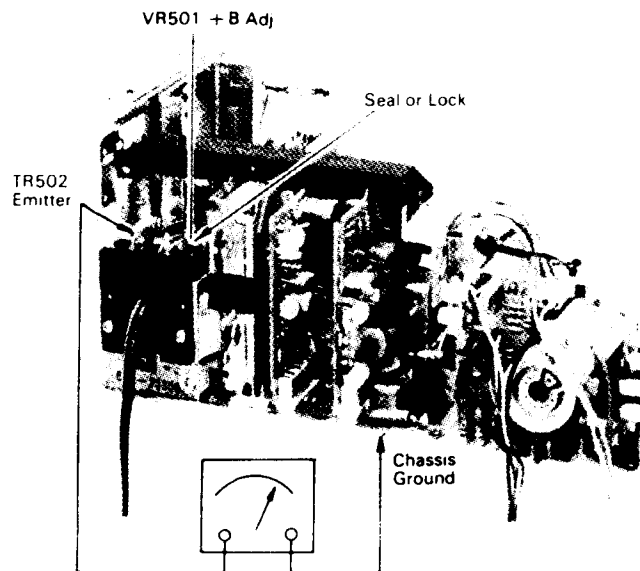

FIGURE 1

BLACK LEVEL CONTROL ADJUSTMENT

This control has been set at the factory and should not need further attention. If however when the game is connected a slight adjustment of VR201 may be necessary to obtain the proper black level (the black portion of the picture just extinguished).

VERTICAL SIZE (HEIGHT)

The vertical height control is a screw-driver adjustment. Location of this control is shown in Fig. 3. This control must be adjusted slowly, if necessary, until the picture or test pattern attains the correct vertical proportions.

CIRCUIT PROTECTION

A 3.0A pigtail fuse, mounted on the Main Board has been provided to protect the Power Output Circuit.

HORIZONTAL OSC. ALIGNMENT

(See Fig. 2)

A warm-up period of at least five minutes should be allowed before alignment is carried out. Set VR351 to center position.

Adjust L351 after grounding R328 plug. (TP32 of Vert/Horiz. P.C. Board) through a 1uF/50V capacitor. Adjust L351 to obtain normal picture.

After adjustment, remove 1uF/50V capacitor.

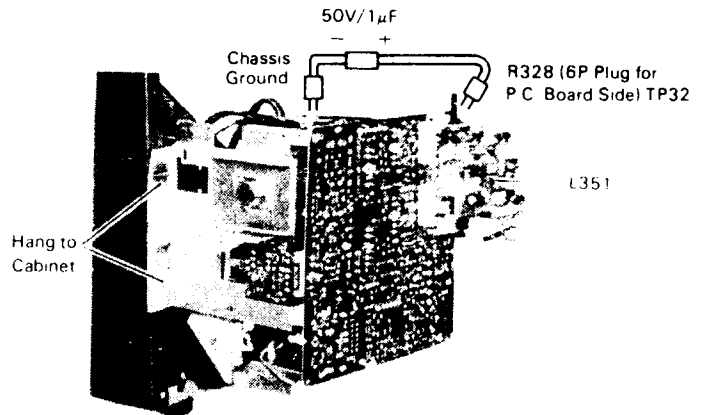

FIGURE 2

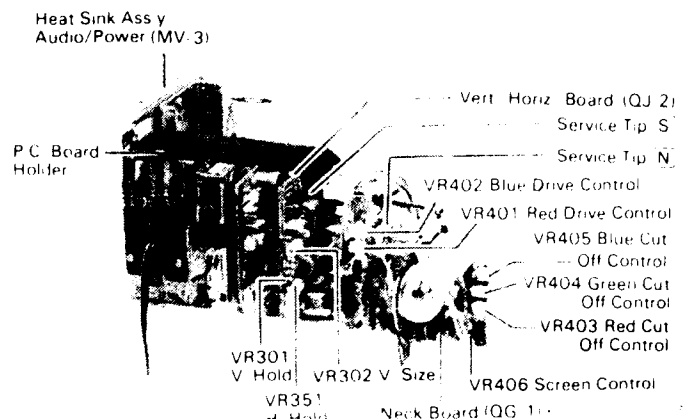

FIGURE 3

INSTALLATION AND SERVICE INSTRUCTIONS

COLOR PURITY AND VERTICAL CENTERING ADJUSTMENT

For best results, it is recommended that the purity adjustment be made in the final monitor location. If the monitor will be moved, perform this adjustment with it facing west or east. The monitor must have been operating 15 minutes prior to this procedure and the faceplate of the CRT must be at room temperature.

The monitor is equipped with an automatic degaussing circuit. However, if the CRT shadow mask has become excessively magnetized, it may be necessary to degauss it with manual coil. Do not switch the coil OFF while the raster shows any effect from the coil.

Purity Magnets are used for Color Purity and V Centering Adjustment.

Purity Adjustment procedure is as follows.

1. Remove R-G-B signal from monitor.
2. Turn Green Cut off Control (VR404) on the Neck Board fully CCW.
Turn Red and Blue Cut off Control (VR405) fully CW.
3. Pull the Deflection Yoke backward so that the Magenta belt will appear. (See Fig. 4)
4. Move the two Purity Magnets and bring the Magenta belt to the mechanical center of the screen (See Fig. 5) The vertical center position should be set VRS to $-5/64$ " (-2 mm) as shown in Fig. 6.
Insert service tip "N" on Neck circuit board to "S" on Vert./Horiz. circuit board (See Fig. 13). To check, use the Green raster at low intensity. Be sure to return the service tips to their original positions for the next check.
5. Push the Deflection Yoke forward gradually and fix it at the place where the Magenta screen becomes uniform throughout.
6. Turn Cut off Control, and Drive Control and confirm that each color is uniform.
7. If the color is not uniform, re-adjust it moving Purity Magnets slightly.
8. Move a pair of Purity Magnets at the same time (do not change the angle of the pair), and adjust the vert. center to center of screen.
9. Obtain the three colors and confirm whether white uniformity is balanced.
10. Insert the temporary wedge as shown in Fig. 5 and adjust the angle of Deflection Yoke.

STATIC CONVERGENCE ADJUSTMENT

A recently developed Deflection Yoke and Electron Guns construction has been used on this equipment in combination with In-Line Guns and Black Stripe Screen to make a barrel-type magnetic-field distribution for vertical deflection and a pin-cushion-type magnetic field for horizontal deflection with which a self-converging system can be obtained. This type is different from conventional unity-magnetic field distribution type deflection yoke. 4-Pole Magnets and 6-Pole Magnets are

employed for static convergence instead of a Convergence Yoke.

1. A cross hatch signal should be connected to the monitor.
2. A pair of 4-Pole Convergence Magnets are provided and adjusted to converge the blue and red beams. When the Pole opens to the left and right 45° symmetrically, the magnetic field maximizes. Red and blue beams move to the left and right oppositely (See Fig. 7-a and 7-b). Variation of the angle between the tabs adjusts the convergence of red and blue vertical lines.

When the both 4-Pole Convergence Magnet Tabs are rotated as a pair, the convergence of the red and blue horizontal lines is adjusted.

3. A pair of 6-Pole Convergence Magnets are also provided and adjusted to converge the magenta (red + blue) to green beams.

When the Pole opens to the left and right 30° symmetrically, the magnetic field is maximized. Red and blue beams both move to the left and right (See Fig. 8-c and 8-d).

Variation of the opening angle adjusts the convergence of magenta to green vertical lines. When both 6-Pole Convergence Magnet Tabs are rotated as a pair the convergence of magenta to green horizontal lines is adjusted.

PRECISE ADJUSTMENT OF DYNAMIC CONVERGENCE (See Fig. 10 and 11)

1. Feed a cross hatch signal to the monitor.
2. Insert the temporary wedge and fix Deflection Yoke so as to obtain the best circumference convergence (See Fig. 10 and 11).

NOTE:

The temporary wedges may need to be moved during adjustments.

4. Insert three rubber wedges to the position as shown in Fig. 9 to obtain the best circumference convergence.

NOTE:

- 1) Tilting the angle of the yoke up and down adjusts the crossover of both vertical and horizontal red and blue lines. See Fig. 10 (a) and (b).
- 2) Tilting the angle of the yoke sideways adjusts the parallel convergence of both horizontal and vertical lines at the edges of the screen. See Fig. 11-a and b.
- 3) Use three rubber wedges (thick and thin rubber wedges are used for a purpose).
- 4) The angle of each rubber wedges are shown in Fig. 9.
- 5) After three rubber wedges have been inserted, pull out the temporary wedge.
- 6) Fix the rubber wedges with chloroprene rubber adhesive.

INSTALLATION AND SERVICE INSTRUCTIONS

BLACK AND WHITE TRACKING (With R/G.B. inputs grounded)

1. Set Black Level Control (VR201) to mid point.
2. Set Red and Blue Drive Controls (VR401 & VR402) to their mechanical center.
3. Set the G2 Screen Control (VR406) and the 3 Cut-off Controls (VR403, VR404, & VR405) to minimum (CCW).
4. Slowly turn up G2 screen control until the first faint color appears.
5. Slowly turn up the other two color cut-off controls in turn to match the first.
6. Remove ground from R/G/B/ inputs. Adjust Red and Blue Drive Controls (VR401 & VR402) for white screen.

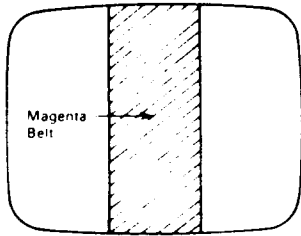

FIGURE 4

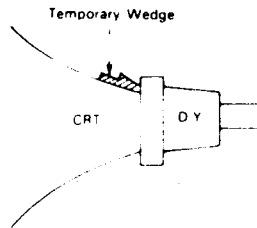

FIGURE 5

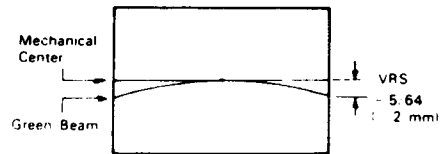
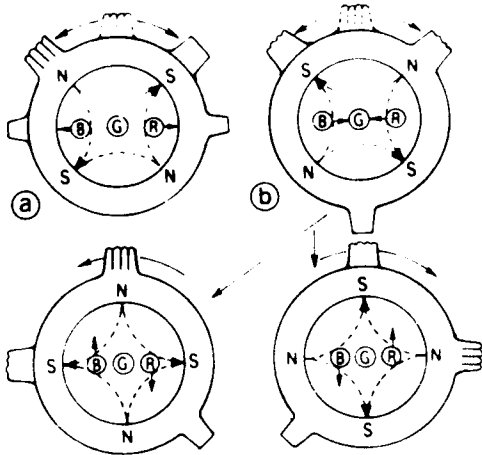
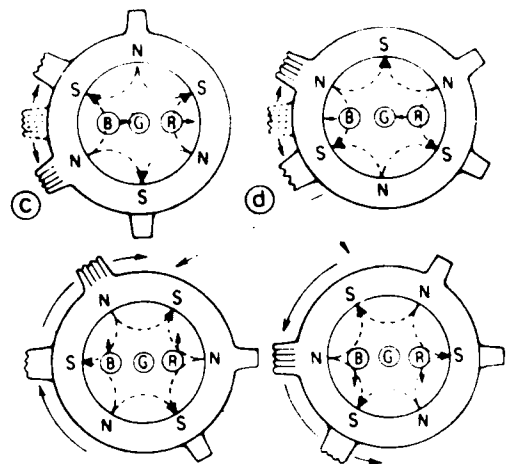

FIGURE 6



4-Pole Magnets and the Movement of Beams

FIGURE 7



6-Pole Magnets and the Movement of Beams

FIGURE 8

INSTALLATION AND SERVICE INSTRUCTIONS

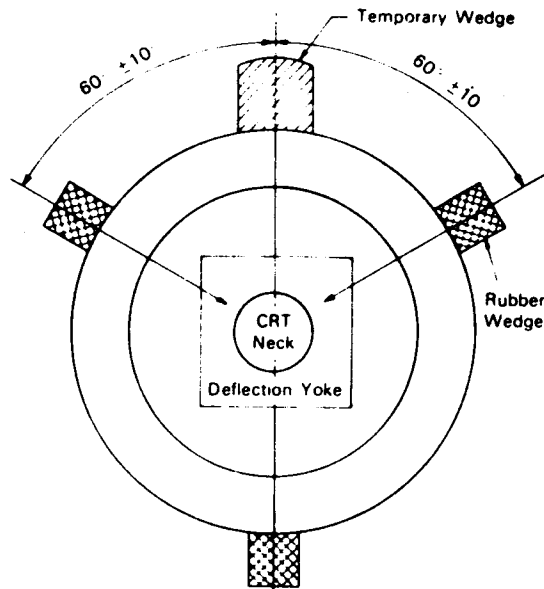
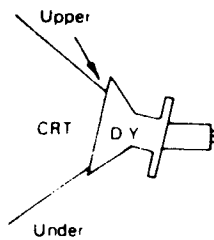
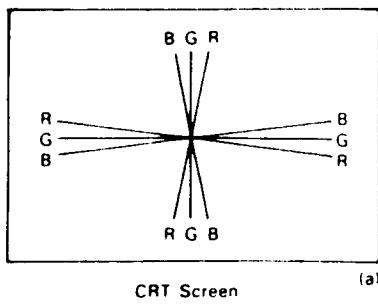
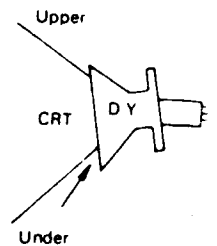
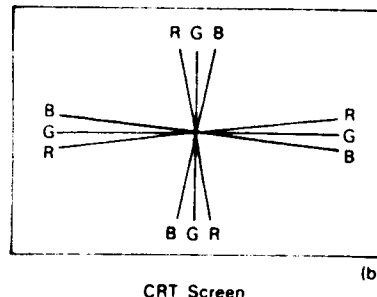

FIGURE 9



Insert Rubber Wedge from Upper Side



Insert Rubber Wedge from Lower Side

FIGURE 10

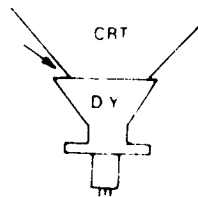
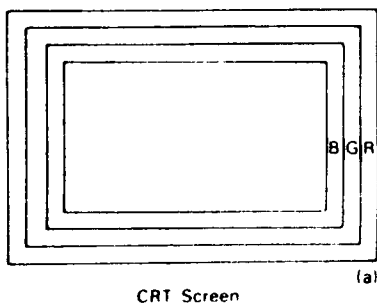

insert Rubber Wedge from Left Side

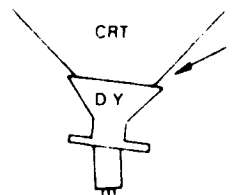
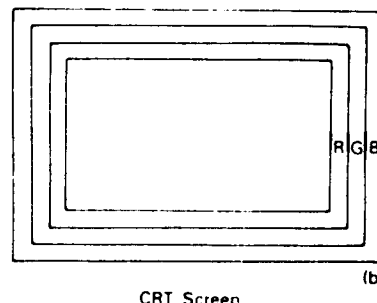

Insert Rubber Wedge from Lower Side

FIGURE 11

INSTALLATION AND SERVICE INSTRUCTIONS

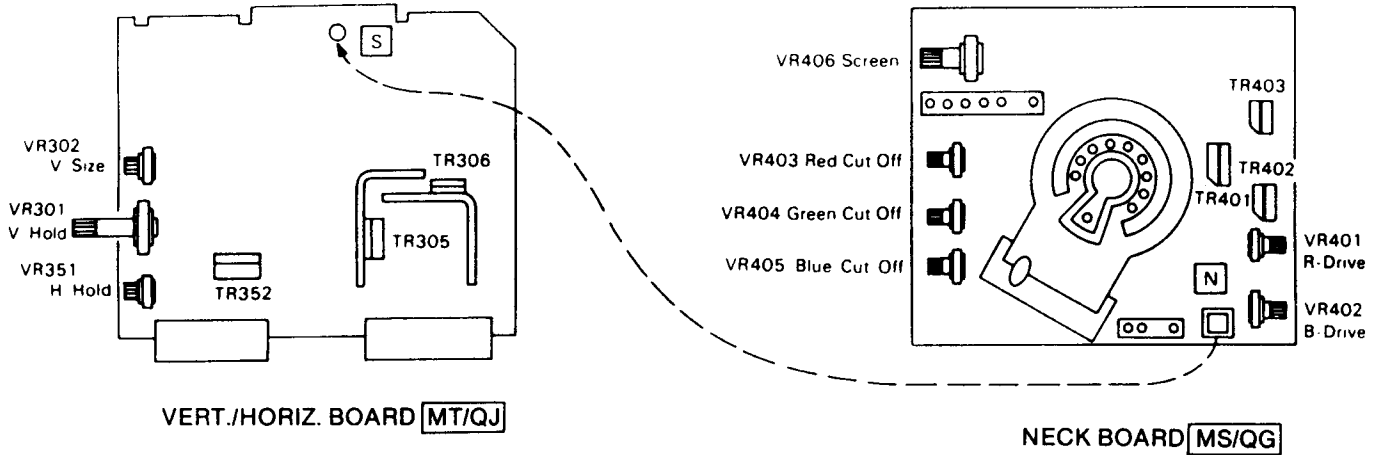

FIGURE 12

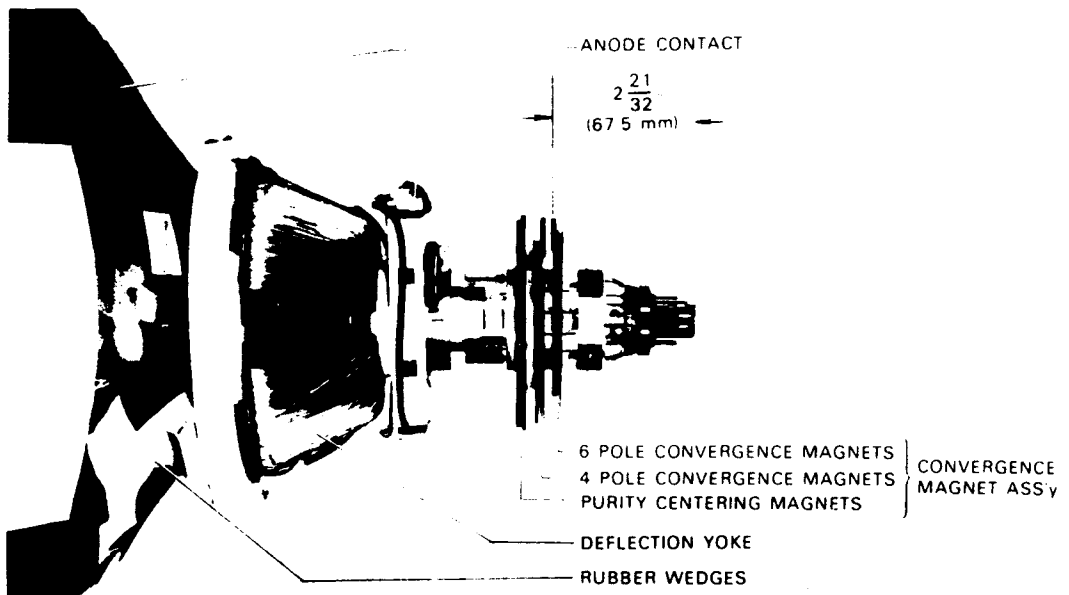

FIGURE 13. PICTURE TUBE NECK COMPONENTS LOCATION

INTERFACE BOARD (P306)

(MODEL 19K4605 & 19K4655)

RESISTORS

R201	340X3910-934	91 Ohm \pm 5%, 1/2W Carbon	R211	340X2331-934	330 Ohm \pm 5%, 1/4W Carbon
R202	340X3183-944	18k Ohm \pm 10%, 1/2W Carbon	R212	340X2331-934	330 Ohm \pm 5%, 1/4W Carbon
R203	340X3102-934	1k Ohm \pm 5%, 1/2W Carbon	R213	340X2331-934	330 Ohm \pm 5%, 1/4W Carbon
R204	340X2101-934	100 Ohm \pm 5%, 1/4W Carbon	R214	340X2151-934	150 Ohm \pm 5%, 1/4W Carbon
R205	340X2333-934	33k Ohm \pm 5%, 1/4W Carbon	R215	340X2151-934	150 Ohm \pm 5%, 1/4W Carbon
R206	340X3331-944	330 Ohm \pm 10%, 1/2W Carbon	R216	340X2151-934	150 Ohm \pm 5%, 1/4W Carbon
R207	340X3102-934	1k Ohm \pm 5%, 1/2W Carbon	R217	340X2101-934	100 Ohm \pm 5%, 1/4W Carbon
R208	340X3102-934	1k Ohm \pm 5%, 1/2W Carbon	R218	340X3102-934	1k Ohm \pm 5%, 1/2W Carbon
R209	340X2333-934	33k Ohm \pm 5%, 1/4W Carbon	R219	340X3102-934	1k Ohm \pm 5%, 1/2W Carbon
R210	340X2101-934	100 Ohm \pm 5%, 1/4W Carbon	VR201	40X0590-017	1.5k Ohm Black Level Control

SEMICONDUCTORS

TR201	86X0121-001	Transistor (NPN) MPS-A20
TR202	86X0121-001	Transistor (NPN) MPS-A20
TR203	86X0121-001	Transistor (NPN) MPS-A20
TR204	86X0066-001	Transistor (PNP) MPS-A70
TR205	86X0066-001	Transistor (PNP) MPS-A70
TR206	86X0066-001	Transistor (PNP) MPS-A70
TR207	86X0121-001	Transistor (NPN) MPS-A20
TR208	86X0121-001	Transistor (NPN) MPS-A20
TR209	86X0121-001	Transistor (NPN) MPS-A20
TR210	86X0121-001	Transistor (NPN) MPS-A20
X201	66X0046-001	Diode Silicon FDH-444
X202	66X0046-001	Diode Silicon FDH-444
X203	66X0046-001	Diode Silicon FDH-444
X204	66X0046-001	Diode Silicon FDH-444
ZD201	66X0040-018	Diode, Zener 6.8V, 5%, 0.5W IN5235B
ZD202	66X0040-019	Diode, Zener 3.9V, 5%, 0.5W IN5228B

MISCELLANEOUS

J201	204X9300-958	Socket, 6 Pin
J202	204X9300-958	Socket, 6 Pin
J203	206X5019-207	Socket, 4 Pin
P201	204X9601-195	Plug, 6 Pin
P202	204X9601-195	Plug, 6 Pin
P203	204X9600-845	Plug, 4 Pin
P204	6A393-003	Plug, 3 Pin
P205	6A0393-006	Plug, 6 Pin

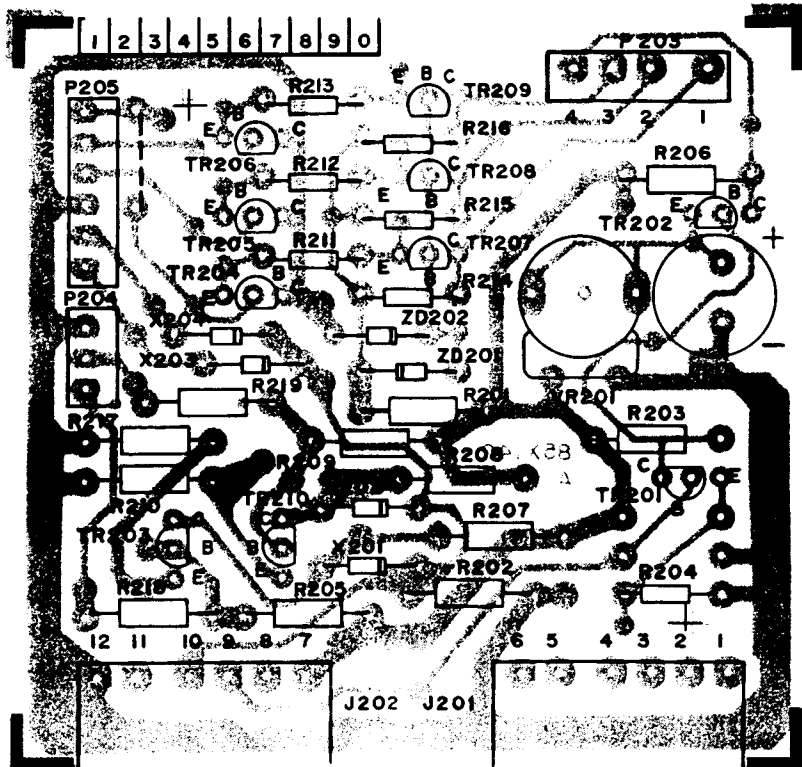

REVISIONS

REV LETTER	ITEM NO	ECN NO	DESCRIPTION	DISPOSITION OF EXISTING PARTS		ENGR'G APP'D
				RE WORK	SCRAP	

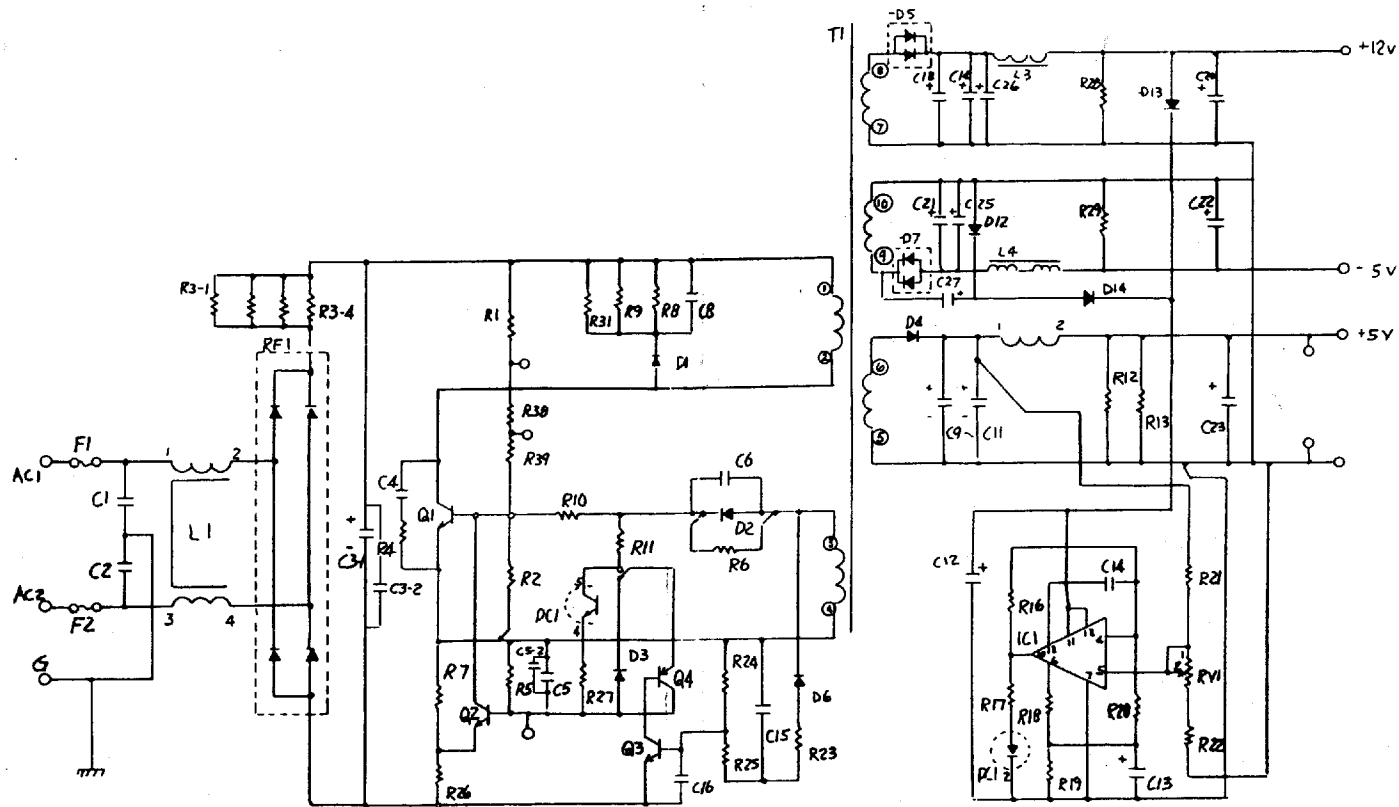

TOLERANCES			
UNLESS OTHERWISE SPECIFIED			
			FRACTIONS ± 1/32
			DECIMALS ± .03
			DECIMALS ± .010
			HOLES ± .005
			ANGLES ± .005

MODEL BYG 310/02
POWER SUPPLY

NEXT ASSEMBLY

COIN DOOR ASSEM.

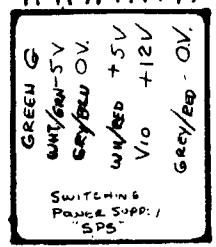
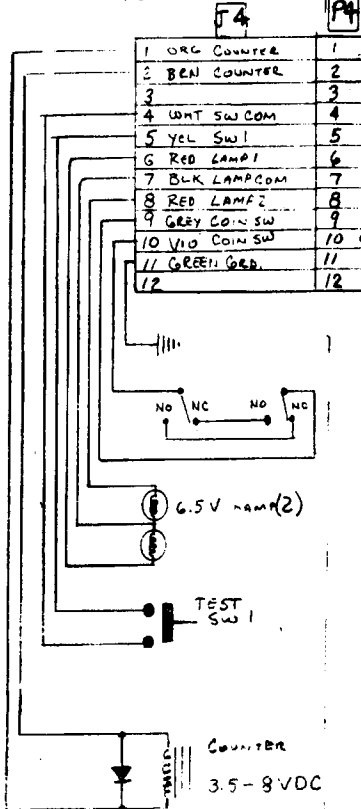

SWINDENSON SWITCHING PWR SUPPLY "SPS" MODEL 8Y6310/02

EX-502 INTERLOCK CABLE ASSY.

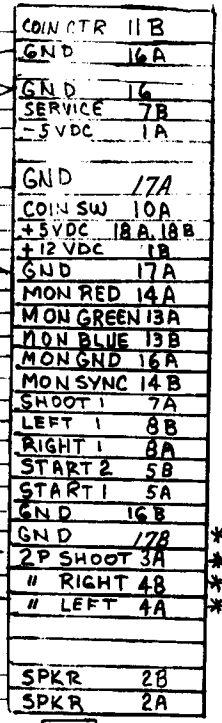
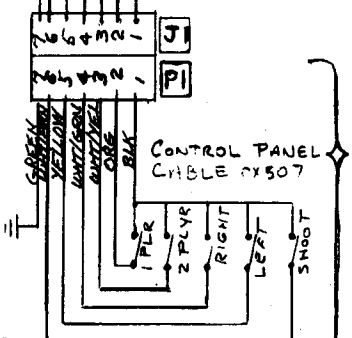
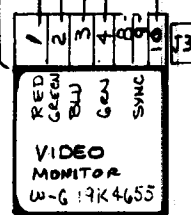

A IS SOLDER SIDE
 B IS PARTS SIDE
 CPU EDGECONNECT
 EX-505

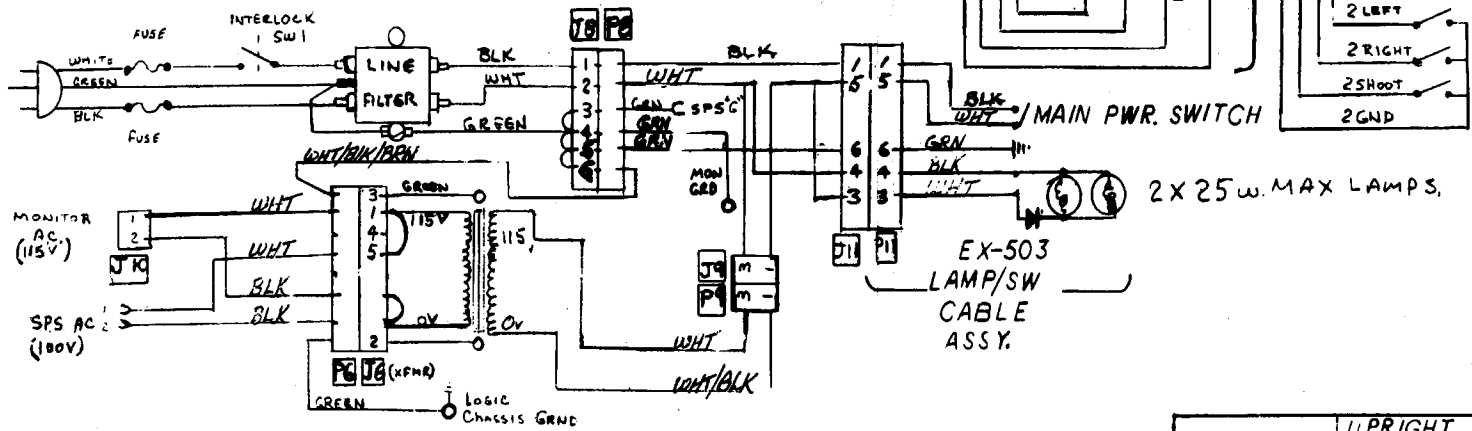

EX-504 MAIN A.C. DISTR. CABLE

EX-501	UPRIGHT VIDEO GAME	LOGIC CABLE SCHEMATIC PRIMARY A.C. DISTR.
		LIL' HUSTLER

Konami

M-1300-1A

34P FLAT CABLE
CONNECTOR

Z-80
IC SOCKET 40P

74LS367 74LS367

74LS367 74LS138

0000H-0FFFH
2732 H1
IC SOCKET 24P

74LS138

0000H-1FFFH
2732 H2
IC SOCKET 24P

74LS138

2000H-2FFFH
2732 H3
IC SOCKET 24P

74LS138

3000H-3FFFH
IC SOCKET 24P

2114-3

2114-3

2114-3

2114-3

74LS02

74LS273

6331-1

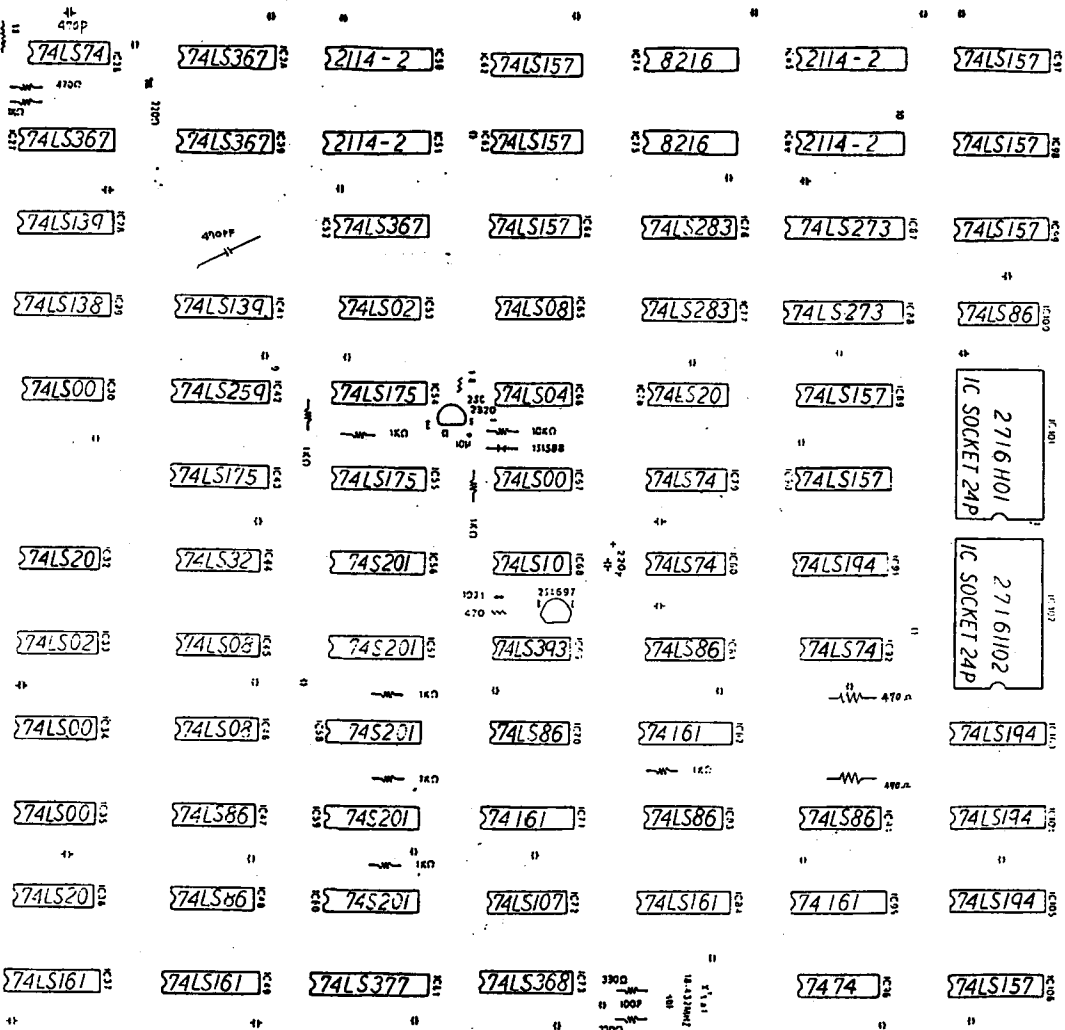

VIDEO HUSTLER UPRIGHT	M-1300-1A 101333
SEMICONDUCTOR LOCATION - MAIN BOARD	

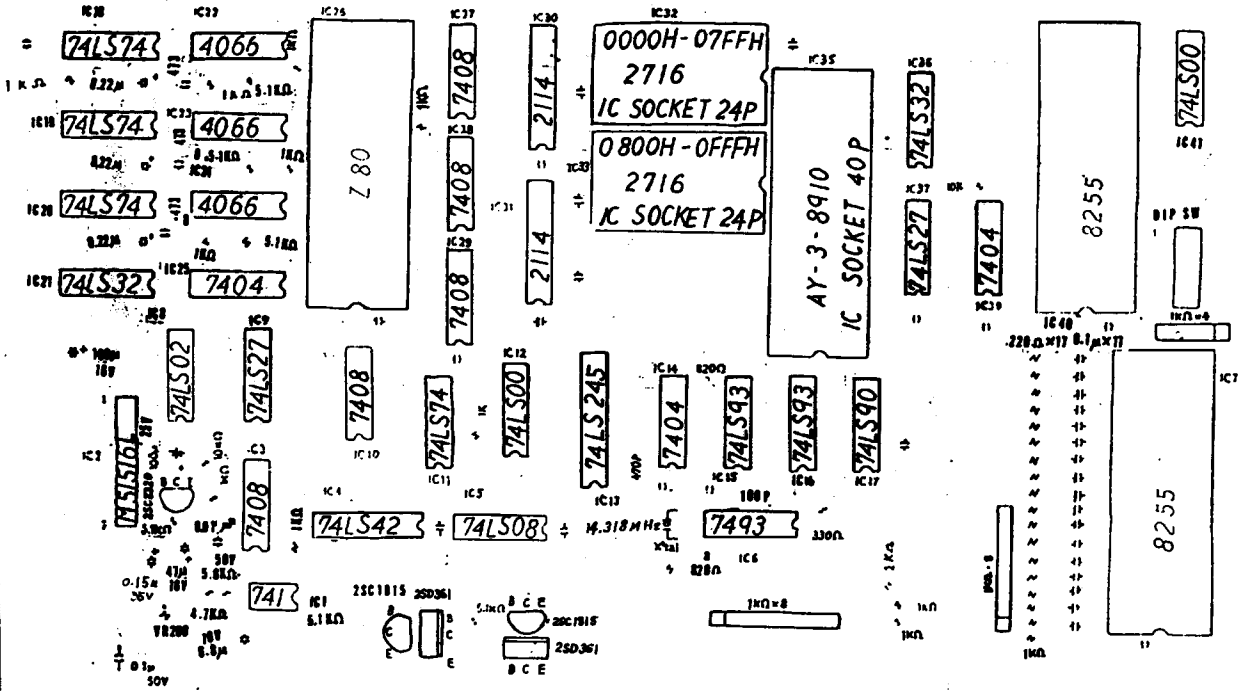

Konami
M-1300-0A

34P FLAT CABLE
CONNECTOR

VIDEO HUSTLER UPRIGHT M-1300-0A
101333

SEMICONDUCTOR
LOCATION
SUB BOARD

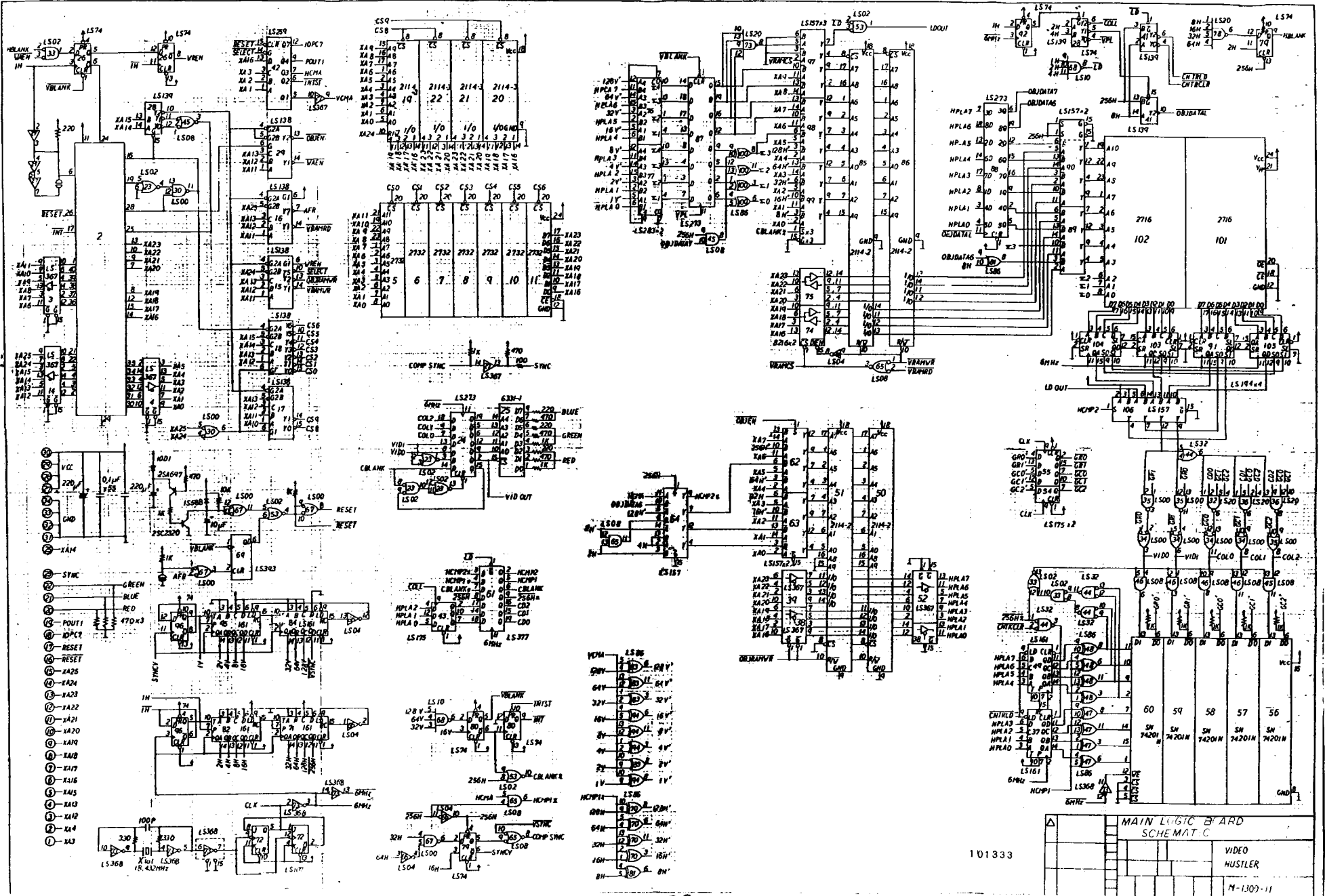

- ① VCC
- ② GND
- ③ XA14
- ④ SYNC
- ⑤ GREEN
- ⑥ BLUE
- ⑦ RED
- ⑧ POINT1
- ⑨ POINT2
- ⑩ RESET
- ⑪ XA25
- ⑫ XA24
- ⑬ XA23
- ⑭ XA22
- ⑮ XA21
- ⑯ XA20
- ⑰ XA19
- ⑱ XA18
- ⑲ XA17
- ⑳ XA16
- ㉑ XA15
- ㉒ XA14
- ㉓ XA13
- ㉔ XA12
- ㉕ XA11
- ㉖ XA10
- ㉗ XA9
- ㉘ XA8
- ㉙ XA7
- ㉚ XA6
- ㉛ XA5
- ㉜ XA4
- ㉝ XA3

MAIN LOGIC BOARD	
SCHEMATIC	
VIDEO	HUSTLER
M-1300-11	

101333

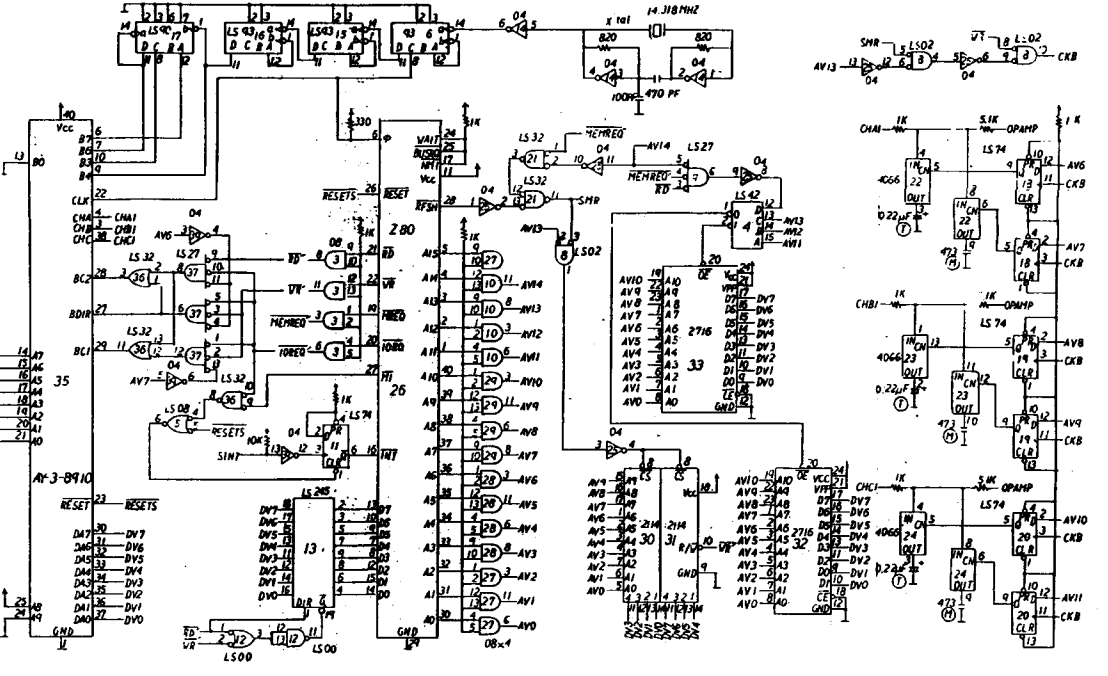
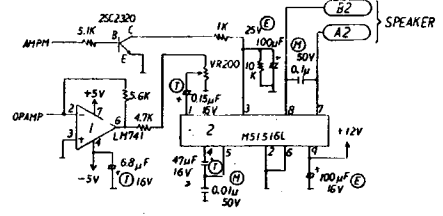
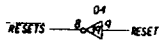
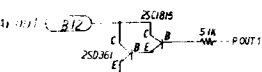
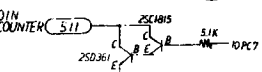
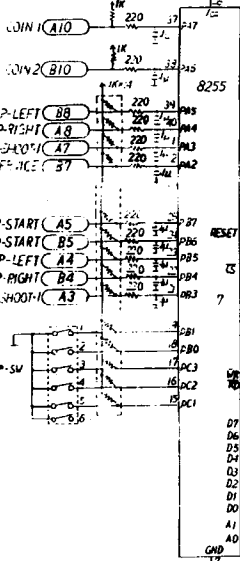
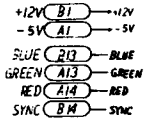
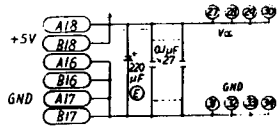
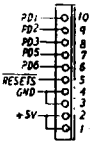
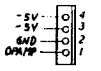

- NOTES
- ①: TANTALUM ELECTROLYTIC CONDENSER.
 - ②: NYLON CAPACITOR.
 - ③: ELECTROLYTIC CONDENSER.
 - NO MARK: CERAMIC CONDENSER.
 - ⓑ2: 36 PIN CONNECTOR.
 - B: parts side.
 - ⓐ: 50 PIN CONNECTOR.
 - ↑: Vcc, +5V
 - Ⓛ: GND, 0V

SUB LOGIC BOARD SCHEMATIC

Doc. 62954



DYNAMO CORPORATION
1805 South Great Southwest Parkway
Grand Prairie, Texas 75051

(214) 641-4286 Toll Free (800) 527-6054 Telex: 732-432