

namco®



Mr DRILLER2 PCB KIT

OPERATION MANUAL



WARNING

- Be sure to read this manual thoroughly before using this unit to ensure safe operations.
- Store this operation manual in a convenient location.

INTRODUCTION

Thank you very much for purchasing Mr. DRILLER2 PC BOARD KIT (hereafter called "this product").

This operation manual explains the following:

- Installing and connecting this product to a general-purpose game cabinet (hereafter called "cabinet") safely,
- Adjusting this product for operation safely,
- Operating this product safely,
- Inspecting, cleaning, troubleshooting this product safely,
- Dismounting, safekeeping, and transporting this product safely,
- Disposing this product safely,
- Making full use of the efficiency of this product to operate it right.

Reference for this product and/or for repair:

Contact your distributor to make inquiries about this product and/or about repair.

1. SAFETY PRECAUTIONS – Be sure to read this part for safe use –

To the owner:

- When the owner of this product entrusts the other person(s) to install this product on the cabinet, to connect, to adjust for operation, to operate, to inspect, to clean, to troubleshoot, to disassemble, to keep, to transport and to dispose, direct such a person(s) to read the applicable part of this manual before conducting the task and to observe the instructions.
- When reselling this product, always attach this operation manual to the PC Board.

1-1 Level of Danger

In this operation manual, the matters that require attention are classified as follows according to the level of the danger:



WARNING: Players and/or technicians can be killed or seriously injured if such danger cannot be avoided.



CAUTION: Players and/or technicians can be slightly injured if such danger cannot be avoided.

The matters that require attention not concerning safety but functions shall be indicated with the mark below.

NOTE : The notices concerning the functions and protection of the product.

1-2 Readers of this operation manual

This operation manual is written for staff of a location operating amusement game machines. But the part noted with “To be serviced by a qualified service technician only” on the Table of Contents and on the title of each chapter is written especially for a qualified service technician. Such a task should be conducted only by a qualified service technician who would fit the following requirements.

A qualified service technician :

A person who works for designing, manufacturing, inspecting, and maintenance servicing at an amusement machine (AM) manufacturer, and a person who has technical knowledge of electrical engineering, electronics, and mechanical engineering equivalent to a graduate of a technical high school or more, and conducts maintenance services (repair) of an AM equipment on a daily basis.

1-3 Safety Precautions

1-3-1 General Safety Precautions



WARNING :

- Do not dismount nor modify this product. Do not conduct any works not described in this operation manual. Otherwise an electrical shock or fire may occur.
- This product is designed for indoor use only. Do not install, connect, or operate this product outdoors. It may cause a fire or electrical shock.
- Be sure to use the replacement parts specified by Namco Ltd. Using substitute parts may cause a fire or electrical shock. Contact your distributor to order parts. The replacement parts are listed under "11. Replacement Parts List" on p.50.
- Do not perform any works with wet hands. Otherwise it may cause an electrical shock.
- Turn OFF the power switch of the cabinet and unplug the power cord from an electrical outlet before conducting any works such as installation and connection , inspection, cleaning, troubleshooting, disassembling. Otherwise an electrical shock may happen.

1-3-2 Safety Precautions When Installing and Connecting



WARNING :

- The power source on the cabinet connected to the JAMMA edge connector should fit the following requirements:
 - Voltage allowable error for +5V should be $\pm 5\%$, Amperage should be 2.5A or more
 - Voltage allowable error for +12V should be $\pm 5\%$, Amperage should be 2A or more
- If the power source does not conform to this requirement, it may cause a fire.

1-3-3 Safety Precautions When Operating



WARNING :

- Should any off-flavor or noise occur, turn OFF the power switch of the cabinet immediately and stop operation. Then unplug the power cord from an electrical outlet and contact your distributor. If the machine is kept operating without solving the trouble, it may cause an electrical shock or fire.
- Make sure that installing and connecting were conducted in accordance with the instructions and the procedure specified in this operation manual (Ref. "5. INSTALLING AND CONNECTING" on p.9) before operation. If it is not installed and connected correctly, it may cause a fire, electrical shock or machine trouble.

1-3-4 Safety Precautions When Disposing



WARNING :

- Do not throw this product into a fire. A lithium battery used in this product may blow to cause injury.
- When disposing this product, collect, transport, and scrap it in accordance with law and orders.
- If entrusting others to collect, transport, and scrap this product, hire specialists in each of such work.

TABLE OF CONTENTS

INTRODUCTION

1. SAFETY PRECAUTIONS – Be sure to read this part for safe use –	1
1-1 Level of Danger	1
1-2 Readers of this operation manual	1
1-3 Safety Precautions	2
1-3-1 General Safety Precautions	2
1-3-2 Safety Precautions When Installing and Connecting	2
1-3-3 Safety Precautions When Operating	3
1-3-4 Safety Precautions When Disposing	3

TABLE OF CONTENTS	4
-------------------------	---

2. SPECIFICATIONS	6
3. CHECK OF PACKAGE	7
4. COMPONENTS	8
5. INSTALLING AND CONNECTING – To be serviced by a qualified service technician only –	9
5-1 Before Installing	10
5-2 Installing the PC Board on the Install Board of the Cabinet	11
5-3 Connecting to the Cabinets Corresponding to the JAMMA Standard	13
5-3-1 Checking the JAMMA Edge Connector	13
5-3-2 Checking the Extended Edge Connector	14
5-3-3 Connecting to the Control Panel	15
5-3-4 Connecting to the Speaker	16
5-3-5 Connecting to the connectors	17
5-4 Pasting the Stickers	19
6. ADJUSTMENT FOR OPERATION	20
6-1 The Basic Knowledge of the Adjustment	20
6-1-1 Adjustment Switches, Knobs	21
6-1-2 Selecting the Adjusting Items	22
6-1-3 Finishing the Test Mode	24
6-2 Display Test (Check/adjustment of the display)	24
6-2-1 Common Operation	25
6-2-2 DIAGONAL (Switching interlace mode/non-interlace mode)	26
6-2-3 COLOR EDIT, COLOR BAR (Adjustment of the shade and tone balance of the picture signal outputted by the PC board)	29

6-2-4 CONVERGENCE (Checking/adjusting the size, position, aspect ratio, distortion of the picture)	30
6-3 SWITCH TEST	32
6-4 SOUND TEST (Test/setting of the sound)	33
6-5 GAME OPTIONS (Setting of the game options)	35
6-6 COIN OPTIONS (Setting of play fees)	37
6-7 A.D.S. (Checking the data on playing results in the past)	39
6-8 DATA CLEAR (Clearing various data, initializing to default settings)	40
7. OPERATION	42
7-1 Persons Not Recommended to Play	42
7-2 Restrictions When Operated	42
7-3 How to Play	43
8. INSPECTION & CLEANING, TROUBLESHOOTING	
– To be serviced by a qualified service technician only –	44
8-1 Inspection & Cleaning	44
8-2 Troubleshooting	45
9. Disassembling, Safekeeping, Transportation	47
9-1 Disassembling –To be serviced by a qualified service technician only –	47
9-2 Safekeeping	49
9-3 Transportation	49
10. DISPOSAL	50
11. REPLACEMENT PARTS LIST	51

2. SPECIFICATIONS

Item	Description
Corresponding Standard	JAMMA standard *1
Dimension	268mm x 230mm x 30mm
Weight	580g
Input power source	[Connected to JAMMA standard terminal] +5V \pm 5% (2.5A or more) and +12V \pm 5% (2.0A or more)
Restriction	Indoor use only Temperature : 0°C - 50°C, Humidity : 10% - 85% (no condensation)
Cabinets applicable to connect	Cabinets corresponding to JAMMA standard
Direction of the monitor and the monitor signal	Direction of the monitor : Sideways Type of scanning retrace line : Switchable to non-interlace / interlace Horizontal synchronizing frequency : 15.75kHz Vertical synchronizing frequency : 60.0Hz
Control panel	4-direction joystick 1 x 2 Button switch 1 x 2 Start switch 1 x 2
How to install it on cabinets	Fix to the wooden install board of the cabinet

- *1 JAMMA standard (JAMMA STANDARD; abbreviated as JS)
Standards on the edge connectors for video game machine PC boards provided by Japan Amusement Machine Manufacturers Association (JAMMA) in 1986

3. CHECK OF PACKAGE

This product consists of the following items when out of the factory.

- NOTES**
- Be sure to check that all the items are included.
 - If there is something missing, contact your distributor.
 - Save the packing materials in case of storage and transportation of this product.

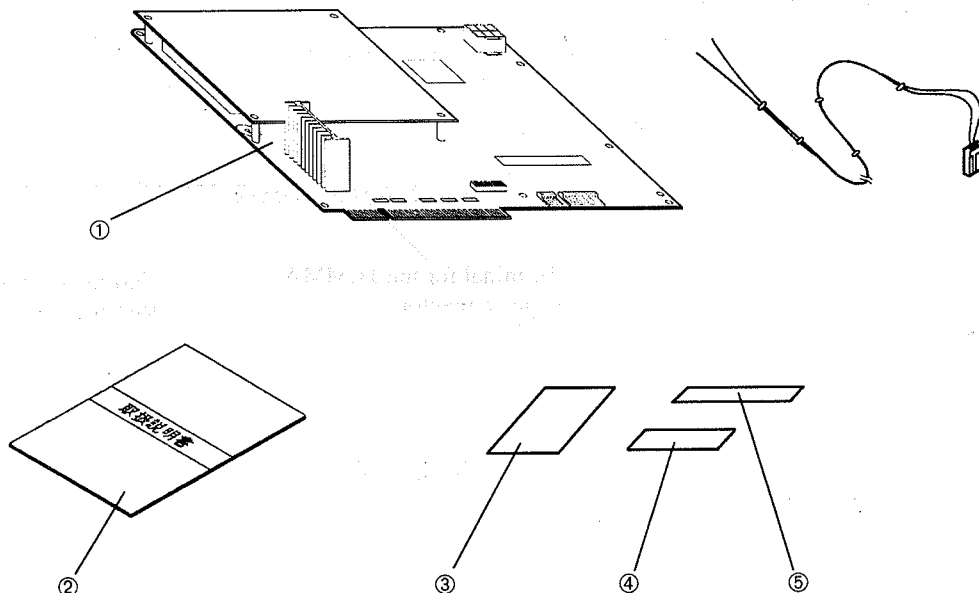

List of items in the package

No.	Item	Remarks	Quantity
①	Mr. DRILLER2 PC Board		1
②	Operation Manual	This operation manual	1
③	Title Sheet	The logotype of Mr. DRILLER2 is printed.	1
④	A Sticker *	List of basic techniques, rectangular sheet.	1
⑤	B Sticker *	Control instructions, rectangular sheet.	1

* The release type of adhesive is used on the adhesive side of the A sticker, B sticker and Button Seal.

Refer to the chapter “11. REPLACEMENT PARTS LIST” on p.50 for the service parts.

4. COMPONENTS

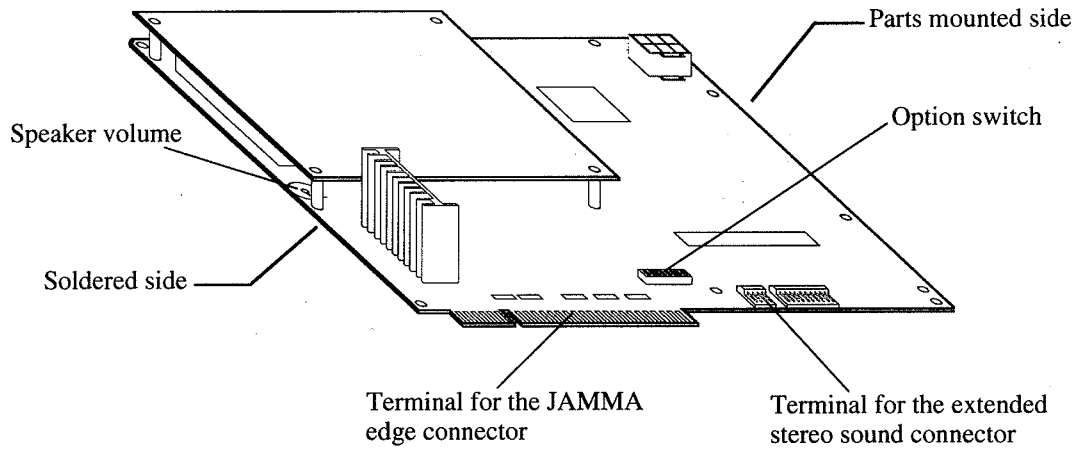

PC Board

5. INSTALLING AND CONNECTING

– To be serviced by a qualified service technician only –



WARNING :

- Always turn off the power switch of the cabinet and unplug the power cord from an electrical outlet before conducting any work. Otherwise an electrical shock may occur.
- This product is designed for indoor use only. Do not install and connect this product outdoors. It may cause a fire or electrical shock.

NOTES

- A service technician should not be charged electricity when installing and connecting the product. Static electricity may cause this product breakdown or damage.
- Do not attempt to perform conductivity test using a multi-meter. Even an internal voltage of a multi-meter may damage the IC of the PC board.

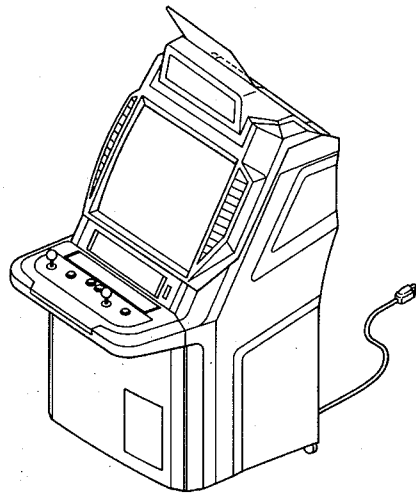

Cabinet

5-1 Before Installing

You prepare the necessary items to install this product as follows.

Items needed	Remarks	Reference
Operation manual attached to your cabinet	Check the handling of your cabinet.	
(+) Countersunk head tapping screw (4 pieces) Diameter: one size smaller than the diameter of installation hole on the side of lesslocks which fix lesslocks on the install board. Length: Long enough to fix the lesslocks on the install board but not too long to stick through the install board	Fix the lesslocks on the install board of your cabinet. You may use the furnished ones with your cabinet.	Chapter 5-2 (page 11)
Lesslock (4 pieces) Those which have holes to be installed on the install board and holes to install the PC board	Keep space between the install board and the PC board. You may use the furnished ones with your cabinet.	Chapter 5-2 (page 11)
Pan head machine screw (4 pieces) Diameter: appropriate size for the PC board installation hole (or internal thread) of the lesslock. Length: Not too long to stick through the lesslock when the PC board is fixed, or not too short to fix it on the lesslock. You can adjust the length by using the spacer mentioned below in cases the screws are too long.	Fix the PC board into the lesslocks. You may use the furnished ones with your cabinet.	Chapter 5-2 (page 11)
Spacer (4 pieces) Minor diameter: appropriate size for the screws mentioned above. Length: appropriate size to adjust the length of the screws above.	Adjust the length of the pan head machine screws when installing the PC board on the lesslocks. Not necessary unless the pan head machine screws are too long. You may use the furnished ones with your cabinet.	Chapter 5-2 (page 11)
Solder or caulking, or crimp-style terminal	Connect wires to micro switches. Please read the referential chapters to check if they are necessary or not.	Chapter 5-3-1 (page 13), Chapter 5-3-3 (page 15), Chapter 5-3-4 (page 16)
Insulating heat contraction tube and a drier for heat contraction tube	Insulate the connection parts of the wires. Please read the referential chapters to check whether they are necessary or not.	Chapter 5-3-1 (page 13), Chapter 5-3-3 (page 15)
Insulating tape	Insulate the edge of unnecessary wires and connectors. Not necessary when connecting to the cabinet corresponding to JAMMA standard with 2 speakers(stereo specification).	Chapter 5-3-4 (page 16), Chapter 5-4-2 (page 20)

5-2 Installing the PC Board on the Install Board of the Cabinet

First install the PC board on the install board according to the following procedure.

- 1 Turn OFF the power switch of the cabinet and unplug the power cord from an electrical outlet.
- 2 Read the part on "Installation of the PC board" of the operation manual of your cabinet, and open the door of the PC board storage and take out the PC board install board.

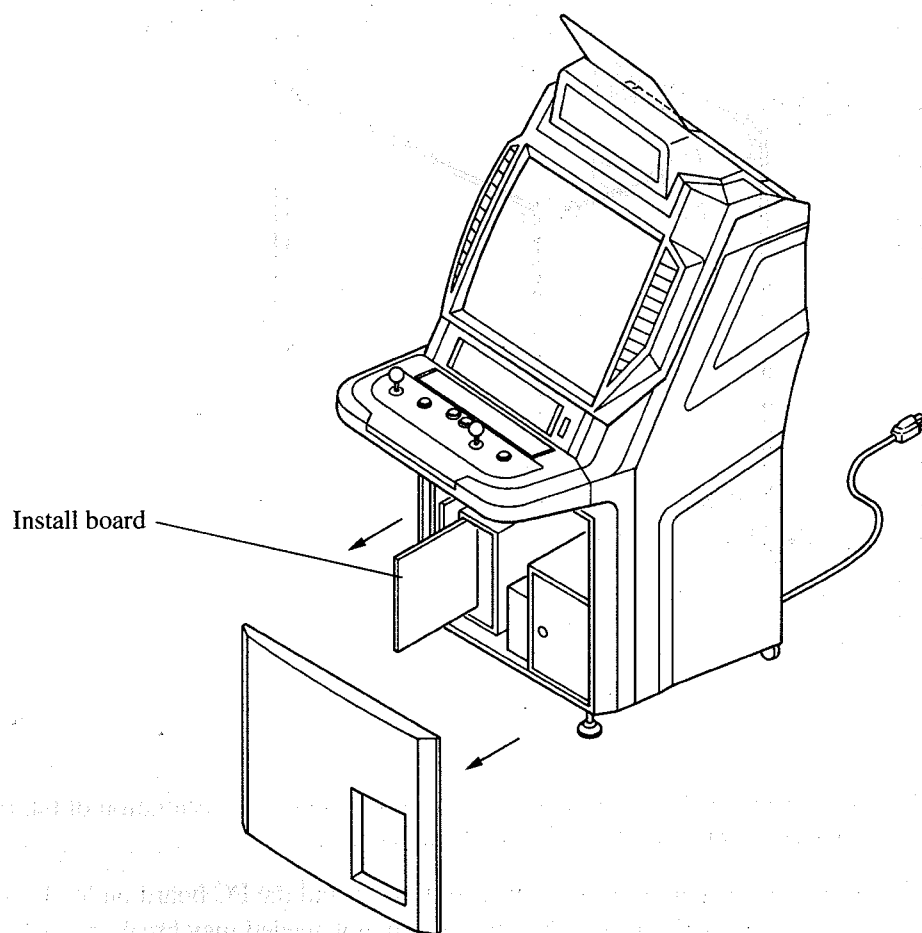

- 3 In cases other PC boards are connected, remove them in accordance with the procedure described in the operation manual of your cabinet.

- 4 Install the PC board at the center of the install board with the countersunk head tapping screws, lesslocks, spacers (unnecessary if the pan head machine screws are not too long) and pan head machine screws, through the four install holes on the PC board.

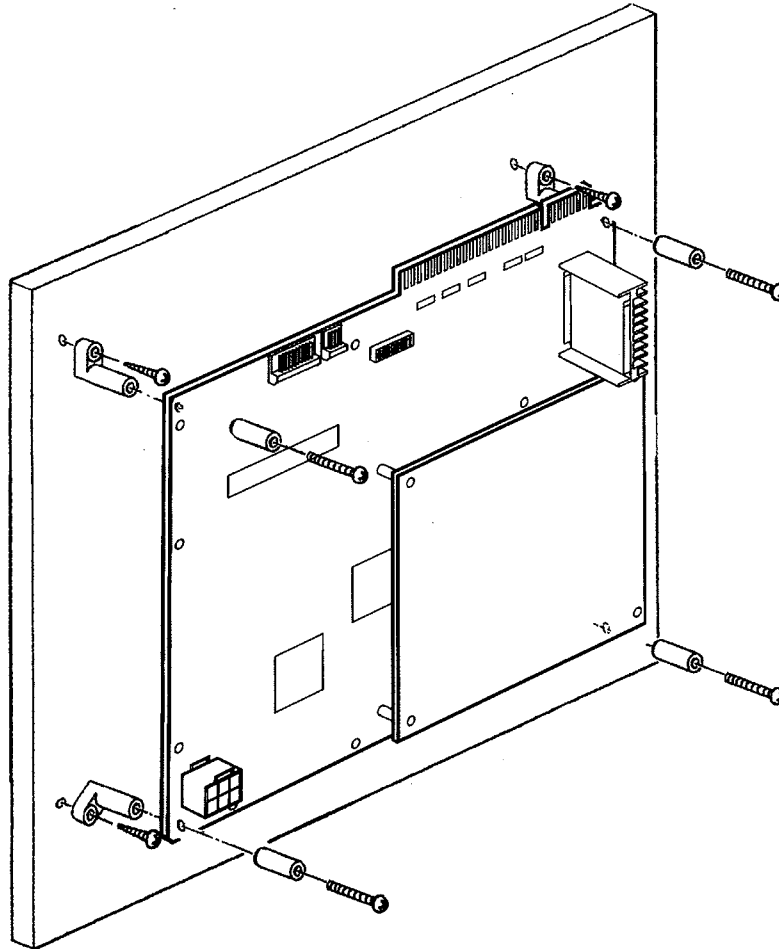

- NOTES**
- Do not use a metal install plate but a wooden board for installation of the PC board. Otherwise it may be short-circuited and damaged.
 - Be sure to use pan head machine screws to install the PC board on lesslocks. Using countersunk head screws when spacers are not needed may break the install holes on the PC board.
 - Clean the cabinet with cleaners if it is dirty with dust.

5-3 Connecting to the Cabinets Corresponding to the JAMMA Standard

5-3-1 Checking the JAMMA Edge Connector

Use the JAMMA edge connector attached to the cabinet to connect this product to the cabinet corresponding to the JAMMA standard.

- 1** Check if the terminal numbers of the JAMMA edge connector of the cabinet conform to the table of JAMMA edge connectors below. If not, connect wires to that part by soldering or fixing applicable crimp-style terminals.

- NOTES**
- Apply insulating heat contraction tube on the connecting part to prevent short-circuit.
 - Nothing should be connected to the blank part of the table below. Otherwise the PC board may break down.

JAMMA Edge Connector (56P 3.96 mm pitch)

Soldered side	Terminal side		Parts mounted side
GND	A	1	GND
GND	B	2	GND
+5V	C	3	+5V
+5V	D	4	+5V
	E	5	
+12V	F	6	+12V
Mis-insert preventive key	H	7	Mis-insert preventive key
Coin counter 2	J	8	Coin counter 1
	K	9	
Speaker (-)	L	10	Speaker (+)
Audio (GND)	M	11	Audio (+)
Video (GREEN)	N	12	Video (RED)
Video (SYNC)	P	13	Video (BLUE)
Service switch	R	14	Video (GND)
	S	15	Test switch
Coin switch 2	T	16	Coin switch 1
P2 start switch	U	17	P1 start switch
P2 joystick (UP)	V	18	P1 joystick (UP)
P2 joystick (DOWN)	W	19	P1 joystick (DOWN)
P2 joystick (LEFT)	X	20	P1 joystick (LEFT)
P2 joystick (RIGHT)	Y	21	P1 joystick (RIGHT)
P2 button switch 1	Z	22	P1 button switch 1
	a	23	
	b	24	
	c	25	
	d	26	
GND	e	27	GND
GND	f	28	GND

- 2 Check the power source for the cabinet connecting to the JAMMA edge connector and voltage of the power source for the coin counter of the cabinet.



WARNING :

- The power source on the cabinet connected to the JAMMA edge connector should fit the following requirements:
 - Voltage allowable error for +5V should be $\pm 5\%$, Amperage should be 2.5A or more
 - Voltage allowable error for +12V should be $\pm 5\%$, Amperage should be 2A or more
- If the power source does not conform to this requirement, it may cause a fire.

- NOTE** ● Voltage of the power source for the coin counter of the cabinet should be +12V or +5V. If higher voltage is used, PC board may malfunction.

5-3-2 Checking the Extended Stereo Sound Connector

To connect this product to the cabinet corresponding to the JAMMA standard, use the extended edge connector attached to this product.

Check if the terminal numbers of the extended edge connector conform to the following table.

- NOTE** ● Nothing should be connected to the blank parts of the table. Otherwise the PC board may break down.

Extended Stereo Sound Connector (EI 4P)

Terminal number	Wire
1	
2	
3	Speaker R (+) (orange)
4	Speaker R (-) (yellow)

5-3-3 Connecting to the Control Panel

This product has to be connected to the control panel (see below) described in the chapter “2. SPECIFICATIONS” (on p.6) to use.

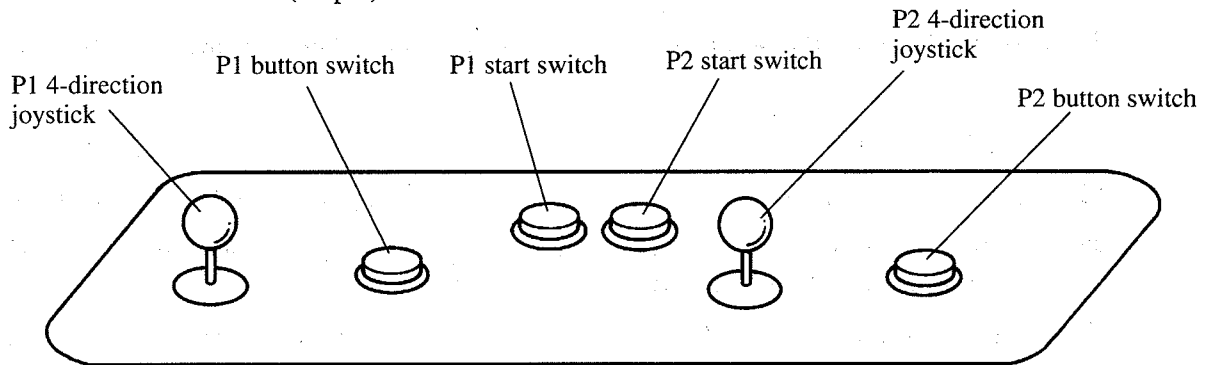

- 1** Turn the power of the cabinet OFF and unplug the power cord from an electrical outlet.
- 2** Remove the control panel in accordance with the instructions on “control panel” described in the operation manual of your cabinet.

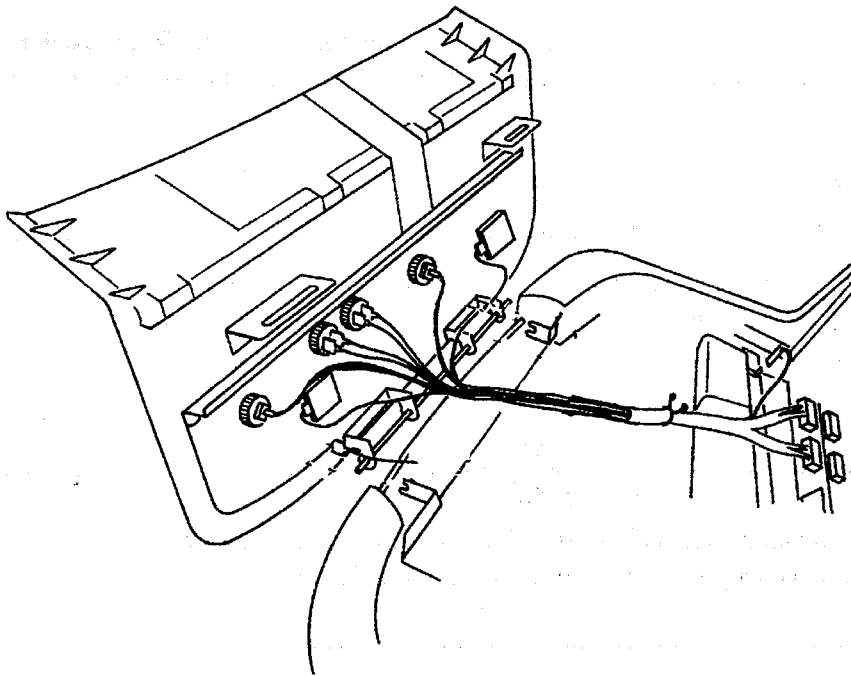

- 3** If the control panel of your cabinet is different from the above drawing, refer to the operation manual of your cabinet and replace the control panel or add/reduce button switches. If some switches are reduced, be sure to fill up the switch holes with hole caps.
- 4** Install the control panel on the cabinet.

5-3-4 Connecting to the Speaker

Connect the product to the speaker(s) of your cabinet in the following procedure so that the cabinet outputs the sound.

First check whether your cabinet has one speaker (monaural) or two speakers (stereo).

● One speaker (monaural)

- 1** Turn OFF the power switch of the cabinet and unplug the power cord from an electrical outlet.
 - 2** Conduct a measure to prevent short-circuit, for instance, wrap the edge of the unused wire (A1, B1) of the extended edge harness with insulating tape.
 - 3** After completing all the following connection, switch to “MONAURAL” in the test mode (Ref. “6-4 SOUND TEST” p.36).
 - “5-2 Installing the PC Board on the Install Board of the Cabinet (p.11)
 - “5-3-1 Checking the JAMMA Edge Connector (p.13)
 - “5-3-2 Checking the Extended Edge Connector (p.14)
 - “5-3-3 Connecting to the Control Panel (p.15)
 - “5-3-5 Connecting to the Connectors (p.17)
- * **This product is set as stereo spec. as the factory-setting. When used as stereo spec. with the cabinet of the monaural spec., only the left speaker outputs the sound.**

● Two speakers

- 1** Turn OFF the power switch of the cabinet and unplug the power cord from an electrical outlet.
- 2** Connect the wires of the terminals A1 and B1 of the extended edge harness to the right side (R) speaker by soldering or fixing an applicable crimp-style terminal in accordance with the following table.



WARNING :

- Always use the extended edge harness specified by Namco Ltd. Otherwise it may cause a fire or electrical shock. Contact your distributor to order parts. Refer to “11. REPLACEMENT PARTS LIST” on p.50 for details of the replacement parts.

Terminal number	Wire
3	Speaker R (+) (orange)
4	Speaker R (-) (yellow)

5-3-5 Connecting to the connectors

- 1** Turn OFF the power switch of the cabinet and unplug the power cord from an electrical outlet.
- 2** Connect the JAMMA edge connector attached to the cabinet and the extended edge connector in the direction shown below so that the mis-insert preventive key would fit the notch of the connector slot of the PC board.

NOTE ● Do not connect the JAMMA edge connector reverse or shifted slightly. The cabinet and PC board may break down.

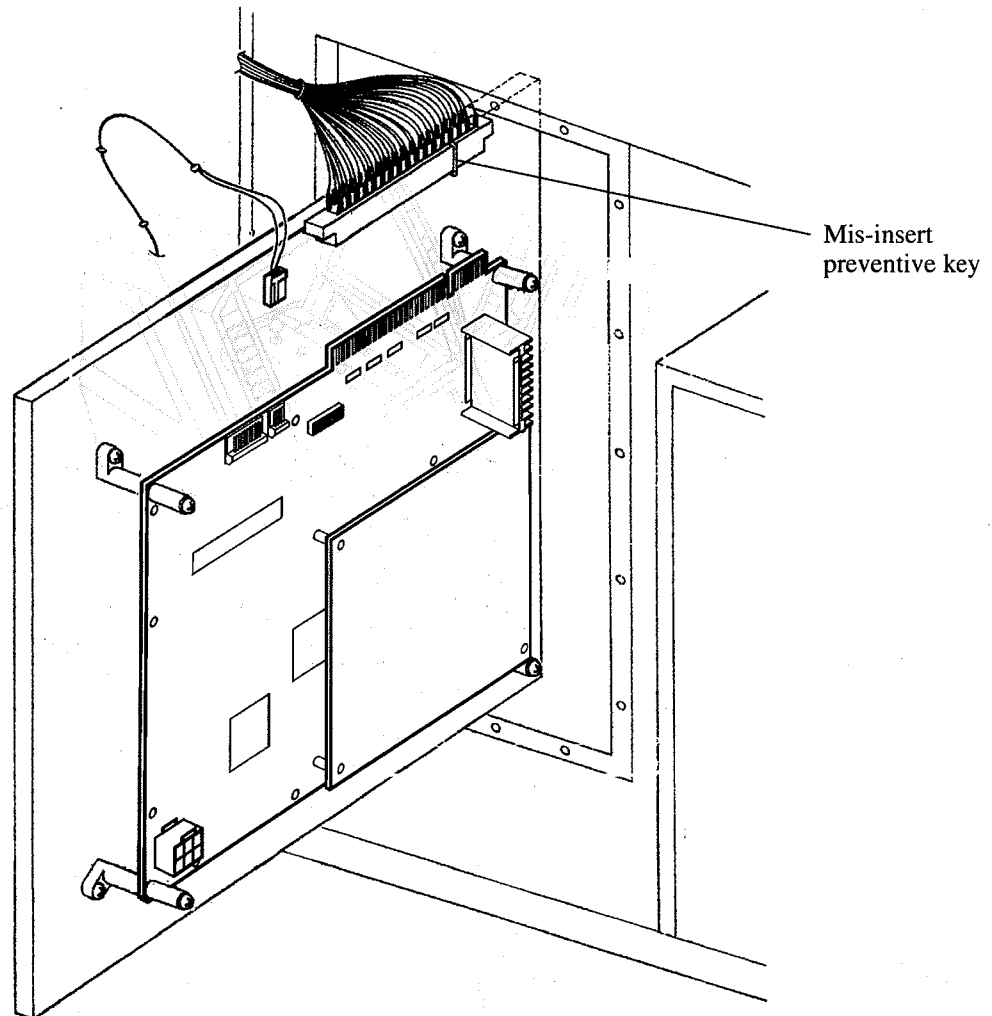

3 Put the PC board installed on the install board into the cabinet.

- NOTES**
- Be sure to fix the install board to the cabinet. If not, it may break down due to vibration.
 - Be careful that the PC board does not touch any harnesses or cables after being put inside the cabinet. If it is kept operating with touching to any of them, it may break down.

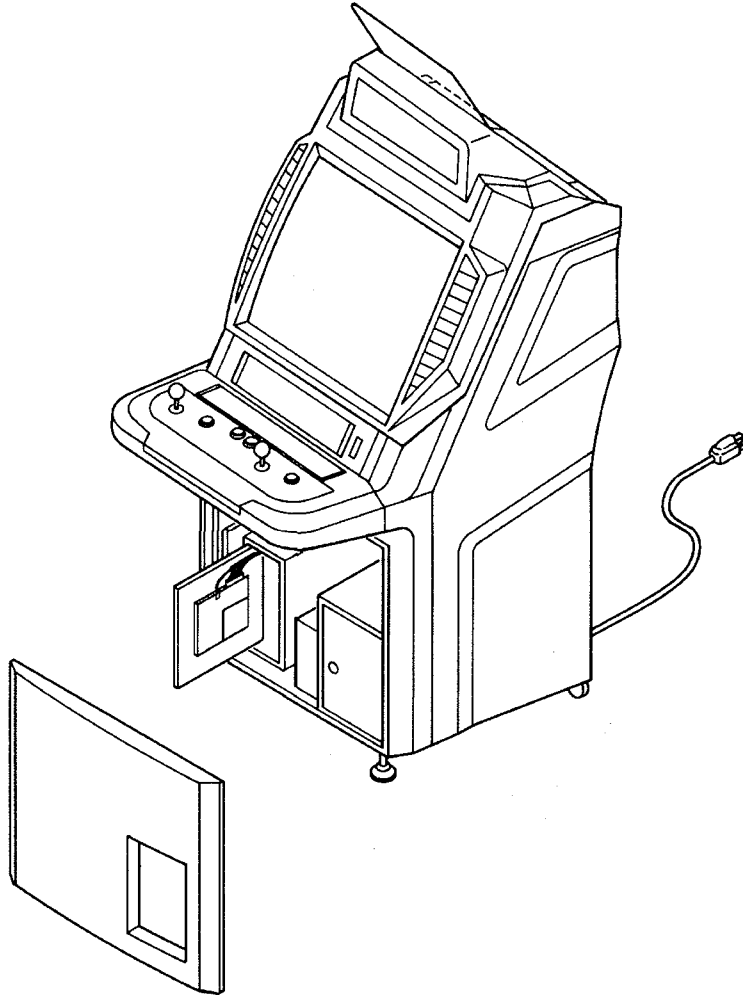

5-4 Pasting the Stickers

Paste the stickers included in the package on the cabinet and install it.

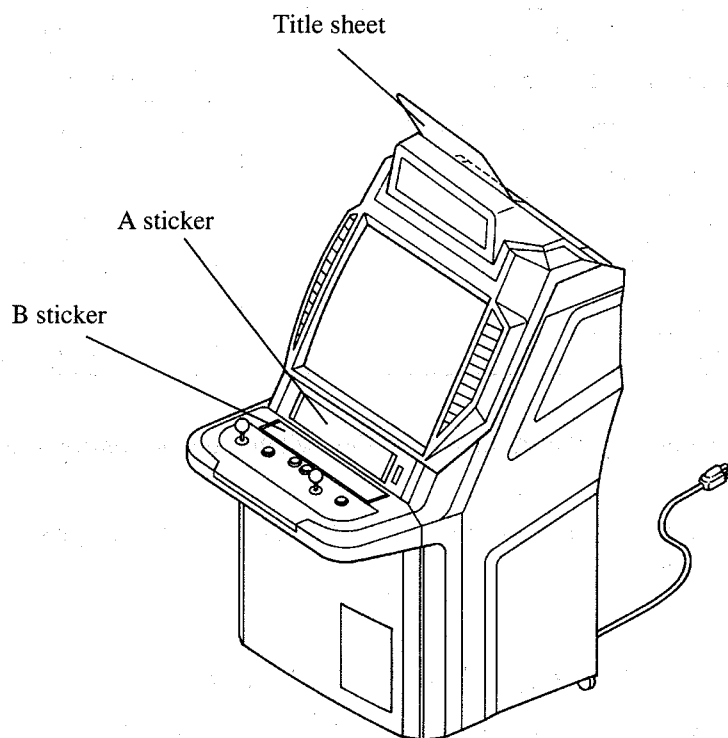

6. ADJUSTMENT FOR OPERATION

The cabinet needs to be conducted adjustment for operation (setting or altering) in order to operate Mr. DRILLER game.

The following items can be adjusted.

Item	Reference
Check/adjustment of the display	6-2 Display Test (p.24)
Testing switches connected to PC board	6-3 Switch Test (p.32)
Testing sound output and setting speakers	6-4 Sound Test (p.33)
Setting of the game options	6-5 Game Options (p.35)
Setting of play fees	6-6 Coin Options (p.37)
Actual play data	6-7 A.D.S. (p.39)
Clear the data	6-8 Data Clear (p.40)

Use the adjustment switches on the PC board and the switches on the control panel of the cabinet to make adjustment.

The basic knowledge of the various adjustment switches and the adjusting procedures necessary for operation shall be explained here.

6-1 The Basic Knowledge of the Adjustment

- ◀ NOTE** ● A service technician should not be charged electricity when touching the PC board. Static electricity may cause the product breakdown or damage.

6-1-1 Adjustment Switches, Knobs

The PC board has a switch and a knob for adjustment, the option switch and speaker volume.

① Option switch

- No.1 shall be used to switch the test mode/game mode.

ON: Test mode
OFF: Game mode

- No.2~8 shall be not used

NOTE ● These should be OFF when operating the game.

② Speaker volume (knob)

This knob adjusts the volume of the speaker sound of the cabinet.

- Turn to right : Sound volume increases
- Turn to left : Sound volume decreases

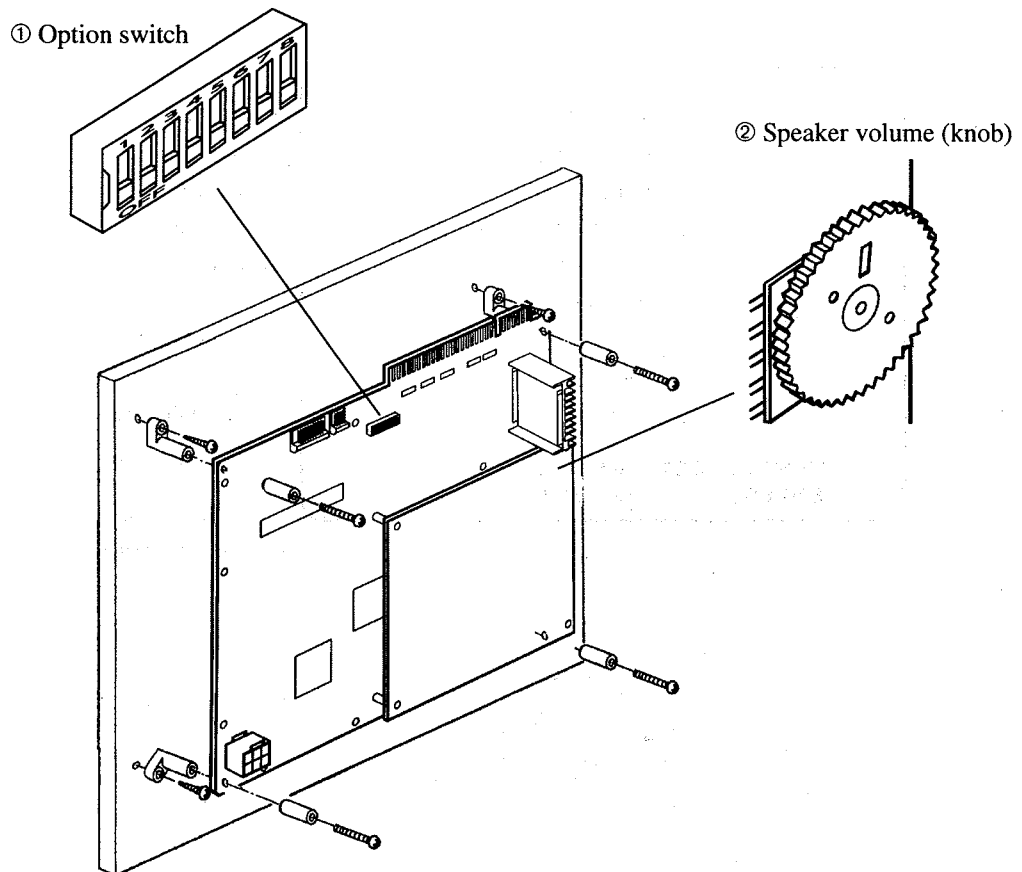

6-1-2 Selecting the Adjusting Items

Display the test menu screen on the test mode to make adjustment.

- 1** Turn the power switch of the cabinet ON to display the game screen.
- 2** Turn No.1 option switch (①) ON.

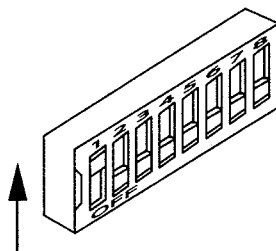

- * Option switch (①) on the PC board and the slide type test switch on the cabinet can make it enter the test mode only when they are switched from OFF to ON. They cannot make it enter the test mode even when they are already set ON. In this case, you have to turn it OFF and then turn it ON again.

It enters the test mode and the test menu screen appears.

- * You may perform the procedure to return to the test menu from each test under “6-2 Display Test” (p.24) through “6-8 Data Clear” (p.40) to display the test menu.

DISPLAY TEST	Display test	----- (6-2)
SWITCH TEST	Switch test	----- (6-3)
SOUND TEST	Sound test	----- (6-4)
JVS CABINET OPTIONS	Cannot select	
GAME OPTIONS	Game option	----- (6-5)
COIN OPTIONS	Coin option	----- (6-6)
A.D.S.	Check play data	----- (6-7)
DATA CLEAR	Data clear	----- (6-8)
EXIT & SAVE	Finishing the test mode	----- (6-1-3)
TEST SELECT :P1-UP or P1-DOWN		
ENTER :P1-BUTTON		

- 3** Hit the P1 4-direction joystick up or down to turn the item to be adjusted in red referring to “6-2 Display Test” (p.24) through “6-9 Data Clear” (p.40).

P1 4-direction joystick

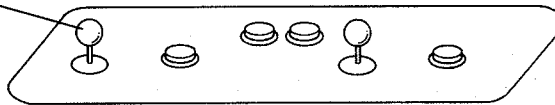

The items to be adjusted can be selected through the following list.

Adjustment	Item to be selected	Reference
Check/adjustment of the display	DISPLAY TEST	p.24
Testing switches connected to PC board	SWITCH TEST	p.32
Testing sound output and setting speakers	SOUND TEST	p.33
Setting of the game options	GAME OPTIONS	p.35
Setting of play fees	COIN OPTIONS	p.37
Actual play data	A. D. S	p.39
Clear the data	DATA CLEAR	p.40

- 4** Press the P1 button switch 1 to select the test screen. The test screen selected is displayed.

P1 start switch

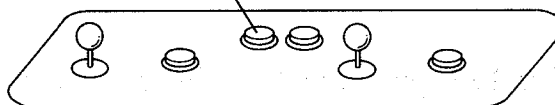

- 5** Make adjustment on the test screen selected.

The detailed adjustment procedure shall be explained under each chapter from “6-2 Display Test” (p.24) through “6-8 Data Clear” (p.40).

6-1-3 Finishing the Test Mode

After making adjustment of each item according to “6-2 Display Test” (p.24) through “6-8 Data Clear” (p.40), display the test menu screen.

- 1 Hit the P1 4-direction joystick up or down to turn “EXIT & SAVE” in red.
- 2 Press the P1 button switch. The test mode finishes and it returns to the game screen.

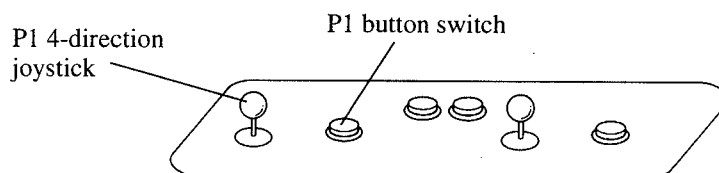

- 3 Turn No.1 option switch (①) OFF.

* In case that the test switch on the cabinet is used, turn that test switch OFF.

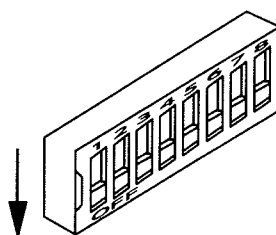

- NOTE** ● If the test mode is not finished in the above procedure, the adjusted result (setting or altering) may not be effective. Always finish the test mode in the above procedure. (The test mode cannot be finished only turning the test switch OFF without selecting “EXIT & SAVE”.)

6-2 Display Test (Check/adjustment of the display)

The following check and adjustment shall be made.

- COLOR EDIT
The shade and tone balance of the picture signal outputted by the PC board shall be checked and adjusted.
- DIAGONAL
The interlace mode display shall be checked.
- COLOR BAR
It is used to check/adjust the shade and the tone balance of the picture.
- CONVERGENCE
It is used to check/adjust the size, position, aspect ratio, distortion of the picture.

Before conducting any of the above, conduct the following “common operation”.

6-2-1 Common Operation

- 1** Perform the procedure **1** - **4** of “6-1-2 Selecting the Adjusting Items” (p.22-23). Select “DISPLAY TEST” in **3**.

“Color Edit” screen shall be displayed over the “diagonal” screen as follows.

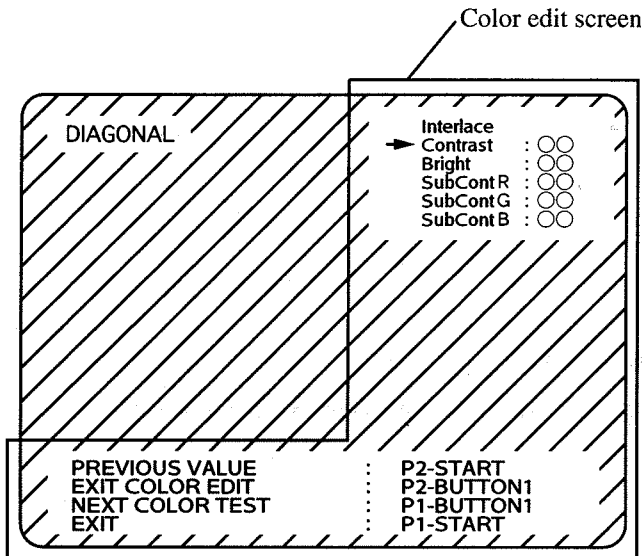

Color edit screen is displayed over the diagonal screen.

- * Pressing the P1 button switch the “color edit” screen displayed/non-displayed.

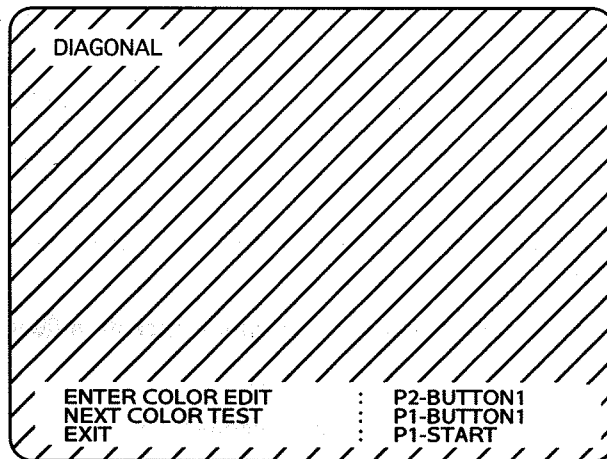

How to enter the color edit mode
 How to go to the next test pattern
 How to return to the test menu screen

The color edit screen is not displayed

2 Press the P1 button switch to go the other adjustment item.

* **Each time you Press the P1 button switch, it shifts from “DIAGONAL” -> “COLOR BAR” -> “CONVERGENCE” -> “DIAGONAL”, and its screen is displayed each time.**

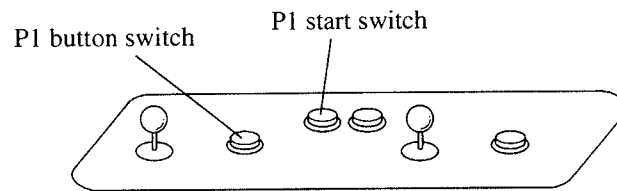

3 According to the item to be adjusted, perform the procedure described under “6-2-2 DIAGONAL” (p.26) through “6-2-4 CONVERGENCE” (p.30).

4 Press the P1 start switch to return to the test menu screen after completing the whole “DISPLAY TEST”. The test menu screen (p.22) is displayed.

5 Perform “6-1-3 Finishing the Test Mode” (p.24) to exit the test mode.

6-2-2 DIAGONAL (Switching interlace mode/non-interlace mode)

Interlace mode: The mode where precise expression, curves and smooth lines shall be displayed compared to “non-interlace mode”.

The vertical resolution is doubled without changing the horizontal/vertical frequency by shifting the display position of the screen to the vertical direction by half of one line once out of twice in display.

* Namco-made CYBERLEAD cabinet corresponds to the interlace mode setting.

Non-interlace mode: The mode to be used when slanted lines are irregular, or the whole screen flickers in “Interlace mode”. This mode keeps the screen pictures uniform every time without shifting the display position of the screen.

1 Perform the procedures **1** and **2** of “6-2-1 Common Operation” (p.25) to display the “Color edit” screen over the “Diagonal” screen.

* **If “DISPLAY TEST” screen appears already, common operation **1** is not needed.**

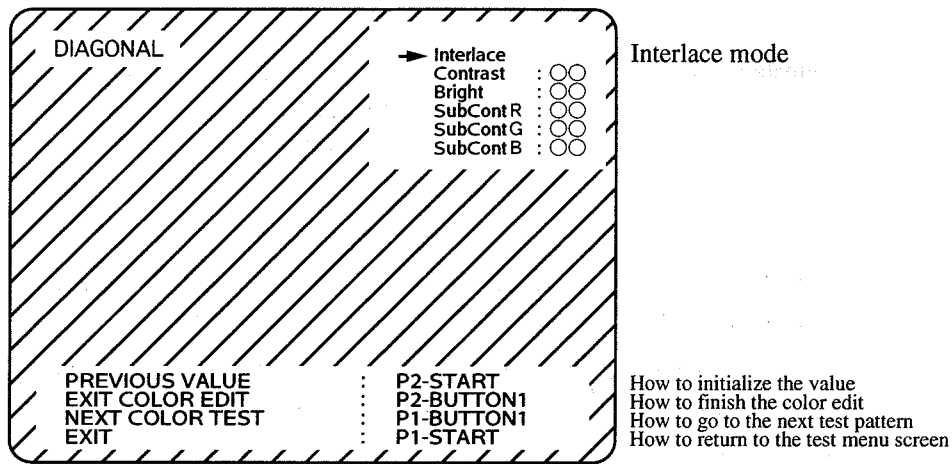

- NOTES**
- If the “DIAGONAL” screen is not displayed, keep pressing the P1 button switch until it is displayed.
 - * Each time you press the P1 button switch, it shifts from “DIAGONAL” -> “COLOR BAR” -> “CONVERGENCE” -> “DIAGONAL”, and its screen is displayed each time.
 - If the “Color Edit” screen is not displayed, press the P2 button switch. The “Color Edit” screen is displayed over the “DIAGONAL” screen.
 - * Press the P2 button switch to switch the “Color Edit” screen displayed / non-displayed.

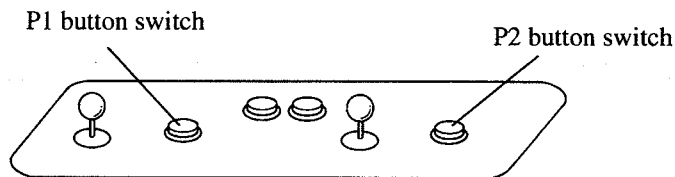

- 2** Make sure that “Interlace” is selected at the right top of the screen.
 - * If it is “Non Interlace”, change the setting to “Interlace” by following the steps below.
 - ① Hit the P1 4-direction joystick to up or down to select “Non Interlace” at the right top of the screen. The arrow on the left of “Non Interlace” shows that it is selected.
 - ② Hit the P1 4-direction joystick to right or left to change the setting from “Non Interlace” to “Interlace”.
- 3** Hit the P1 4-direction joystick to right at the same time to check that slanted lines are not irregular in every color, or the whole screen does not flicker.

- * Each time you Hit the P2 4-direction joystick to right, the color of the slanted lines pattern changes from white -> blue -> red -> purple -> green -> light blue -> yellow -> black -> whitein this order.
- * In the Interlace mode, precise picture can be displayed compared to the Non Interlace mode. Due to the nature of the Interlace mode, however, some types of monitor cannot display the right picture, where slanted lines may be irregular or the whole screen may flicker.

4 When slanted lines are irregular or the whole screen flickers, switch “Interlace” to “Non Interlace” at the top right of the screen following the steps below.

- ① Hit the P1 4-direction joystick to up or down to select “Interlace” at the right top of the screen. The arrow on the left of “Interlace” shows that it is selected.
- ② Hit the P1 4-direction joystick to right or left to change the setting from “Interlace” to “Non Interlace”.

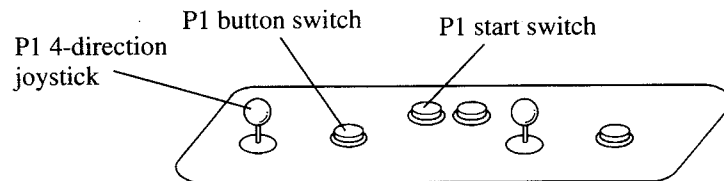

5 Press the P1 start switch to return to the test menu screen after completing the whole “DISPLAY TEST”.

Press the P1 button switch 1 to display the adjusting screen for the other adjustment in the “DISPLAY TEST”.

6 Perform “6-1-3 Finishing the Test Mode” (p.24) to exit the test mode.

6-2-3 COLOR EDIT, COLOR BAR (Adjustment of the shade and tone balance of the picture signal outputted by the PC board)

1 Perform the procedures **1** and **2** of “6-2-1 Common Operation” (p.25) to display the “Color Edit” screen over the “Color Bar” screen.

* If “DISPLAY TEST” screen appears already, common operation **1** is not needed.

In the “Color Bar”, the following screen appears.

* Each color bar of “white” “red” “green” “blue” is displayed with gradual shading. Hit the P2 4-direction joystick to right to change the shade and tone of the color from 32 -> 16 -> 8 -> 4 -> 2 -> 32in this order.

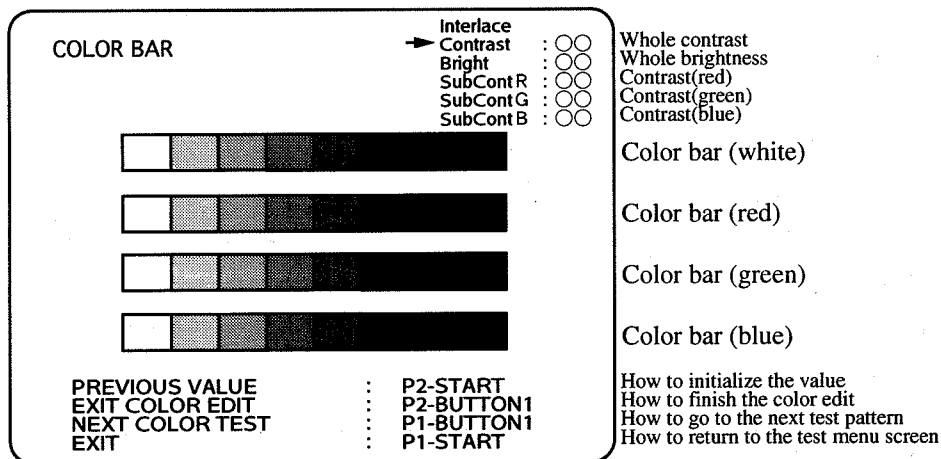
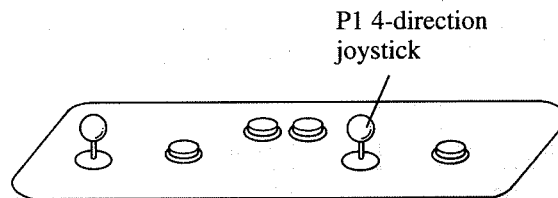

NOTES ● If the “COLOR BAR” screen is not displayed, keep pressing the P1 button switch to down until it is displayed.

* Each time you press the P1 button switch, it shifts from “DIAGONAL” -> “COLOR BAR” -> “CONVERGENCE” -> “DIAGONAL”, and its screen is displayed each time.

● If the “Color Edit” screen is not displayed, press the P2 button switch. The “Color Edit” screen is displayed over the “COLOR BAR” screen.

* Press the P2 button switch the “Color Edit” screen displayed / non-displayed.

- 2** Hit the P1 4-direction joystick to up or down to select the adjusting item out or Contrast”, “Bright”, “SubCont R”, “SubCont G”, and “SubCont B”.

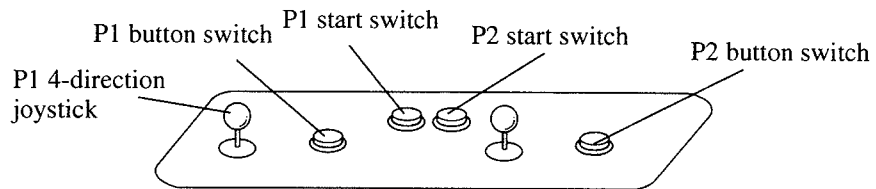

- 3** Hit the P1 4-direction joystick to right or left to change the setting.

* The details of the adjustment is shown in the table below. The result of the adjustment shall be checked on the color bar on the screen.

Item	Description
Contrast	Adjusting contrast of the picture
Bright	Adjusting shade and tone of the picture
SubCont R	Adjusting contrast of red color of the picture signal
SubCont G	Adjusting contrast of green color of the picture signal
SubCont B	Adjusting contrast of blue color of the picture signal

* After changing the setting,

- To initialize the settings, press the P2 start switch. The changed settings are erased.
- To stop adjusting, press the P2 button switch. The “Color Edit” screen disappears and adjustment is suspended.
- To re-adjust, press the P2 button switch again. The “Color Edit” screen appears again for re-adjustment.

- 4** Press the P1 start switch to return to the test menu screen after completing the whole “DISPLAY TEST”.

Press the P1 button switch to display the adjusting screen for the other adjustment in the “DISPLAY TEST”.

- 5** Perform “6-1-3 Finishing the Test Mode” (p.24) to exit the test mode.

6-2-4 CONVERGENCE (Checking/adjusting the size, position, aspect ratio, distortion of the picture)

- 1** Perform the procedures **1** and **2** of “6-2-1 Common Operation” (p.25) to display the “CONVERGENCE” screen.

* If “DISPLAY TEST” screen appears already, common operation **1** is not needed.

NOTES

● If the “CONVERGENCE” screen is not displayed, keep pressing the P1 button switch until it is displayed.

* Each time you press the P1 button switch, it shifts from “DIAGONAL” -> “COLOR BAR” -> “CONVERGENCE” -> “DIAGONAL”, and its screen is displayed each time. On the “CONVERGENCE” screen, the following “cross hatch pattern” is displayed.

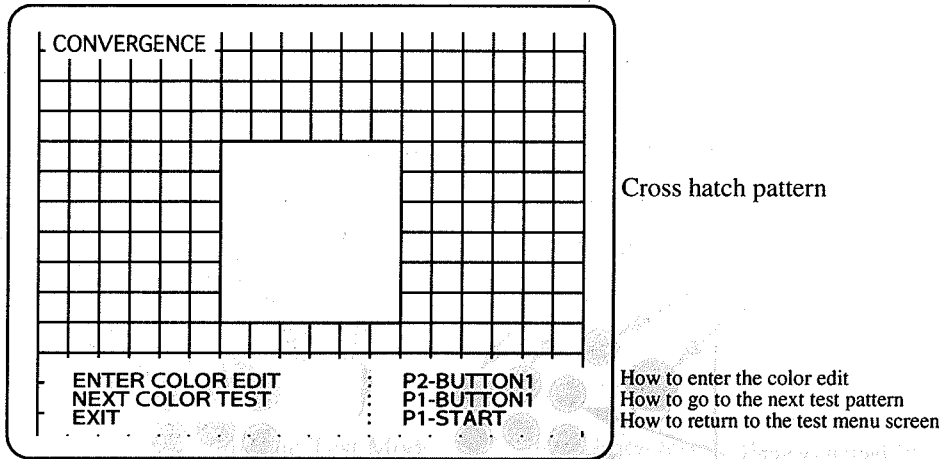

Note: The above shows the screen with the color edit non-displayed. It makes no difference if the color edit is displayed.

2 Hit the P2 4-direction joystick to right at the same time to check the size, position, aspect ratio, and distortion of the cross hatch pattern on each color.

* Each time you hit the P2 4-direction joystick to right at the same time, the color of the “cross hatch pattern” changes from white -> blue -> red -> purple -> green -> light blue -> yellow -> black -> whitein this order.

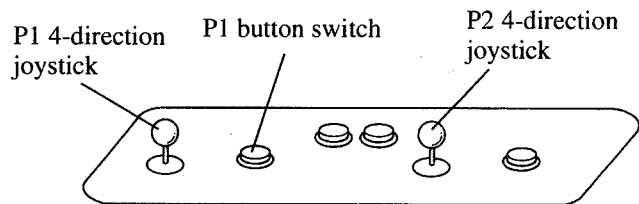

3 When the size, position, aspect ratio of the pattern is not appropriate or distorted, refer to the operation manual of the cabinet or contact the manufacturer of the cabinet to adjust it on the cabinet.

4 Press the P1 start switch to return to the test menu screen after completing the whole “DISPLAY TEST”.

Press the P1 button switch to display the adjusting screen for the other adjustment in the “DISPLAY TEST”.

5 Perform “6-1-3 Finishing the Test Mode” (p.24) to exit the test mode.

6-4 SWITCH TEST

Use the SWITCH TEST function to test the switches connected to the PC board such as the buttons on the control panel.

- 1 Perform the procedure 1 - 4 of "6-1-2 Selecting the Adjusting Items" (p.22-23). Select "SWITCH TEST" in 3.

The following screen is displayed.

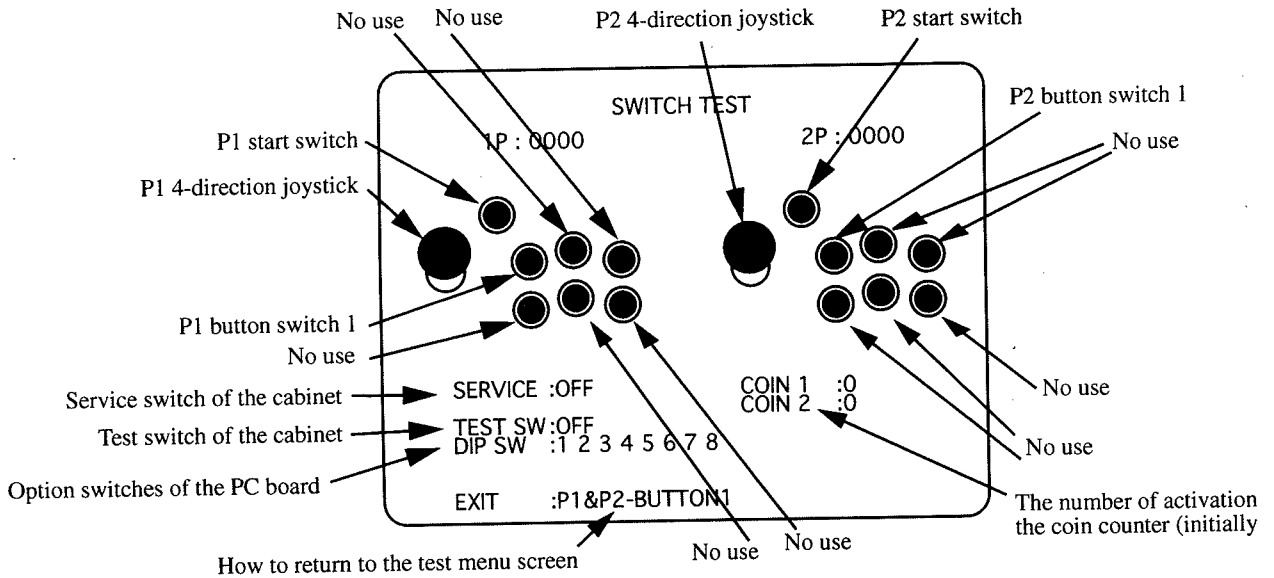

- Notes:
- The button switches not specified in the above figure shall not be used.
 - The current status shall be displayed under "SERVICE", "TEST SW", "DIP SW", "COIN 1", "COIN 2". (In case that there is only one coin counter, 0 shall be displayed under "COIN 2".)

- 2 Operate each joystick and switch on the control panel one by one.

* The joysticks on the screen moves in accordance with the actual moves of "P1 4-direction joystick". The button on the screen is highlighted in white when the actual button switch on the control panel is pressed.

NOTE ● If the screen does not change in accordance with the operation of the joysticks and the switches on the PC board, the game play cannot be played correctly. Refer to "8-2 TROUBLESHOOTING" (p.45) in that case.

- 3 Press the P1 button switch and P2 button switch at the same time to return to the test menu screen.

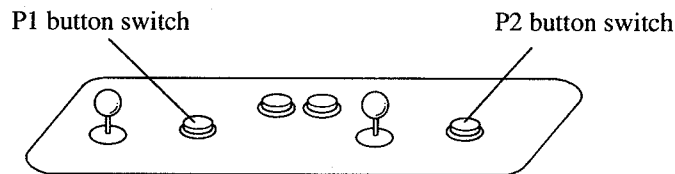

- 4 Perform "6-1-3 Finishing the Test Mode" (p.27) to exit the test mode.

6-4 SOUND TEST (Test/setting of the sound)

Testing of the sound output of the cabinet and the setting of the speakers monaural/stereo shall be made here.

- 1 Perform the procedure 1 - 4 of "6-1-2 Selecting the Adjusting Items" (p.22-23). Select "SOUND TEST" in 3. Tdistributor to make inquiries about this product and/or about repair.

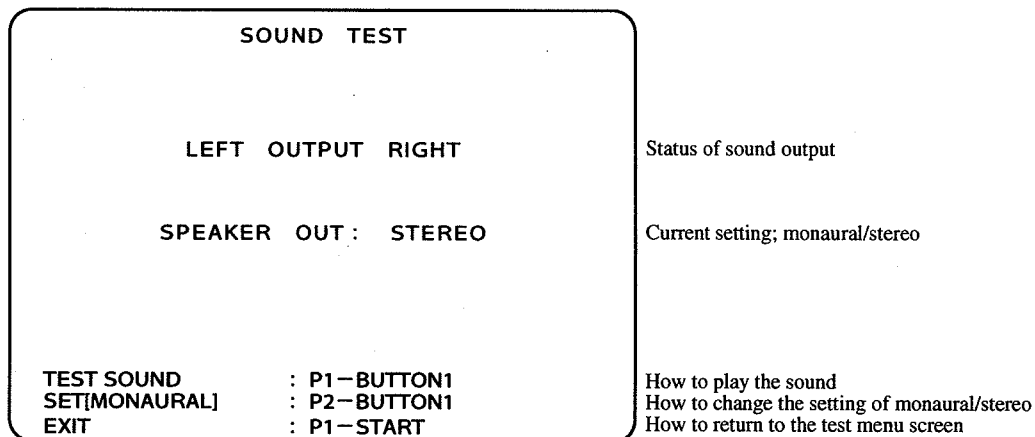

- 2** Make adjustment according to the description on the table below with the appropriate joystick and the switch.

Item	Test/Adjustment	How to operate
Stereo sound test	Stereo sound output is tested.	Press the P1 button switch. The sound is played from the left speaker, right speaker, and finally both speakers as stereophonic.
Switch monaural/stereo	Monaural sound/stereo sound is switched.	Press the P2 button switch.

NOTE ● If something wrong is found when checking the adjustment, refer to “8-2 TROUBLESHOOTING” on p.45.

- 3** Press the P1 start switch to return to the test menu screen.

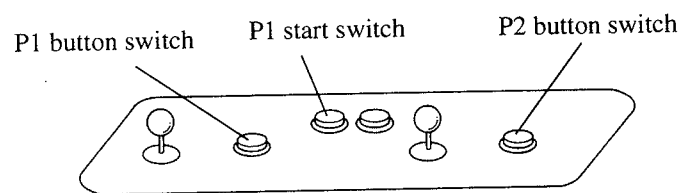

- 4** Perform “6-1-3 Finishing the Test Mode” (p.24) to exit the test mode.

6-5 GAME OPTIONS (Setting of the game options)

Game options such as the game difficulties shall be set here.

- 1 Perform the procedure **1** - **4** of "6-1-2 Selecting the Adjusting Items" (p.22-23). elect "GAME OPTIONS" in **3**.

The following screen is displayed.

```

-----1P PLAY MODE-----:
(a) 500m(2500ft) DIFFICULTY LEVEL :MEDIUM
(b) 1000m(5000ft) DIFFICULTY LEVEL :MEDIUM
(c) 2000m(10000ft) DIFFICULTY LEVEL:MEDIUM
(d) LIVES :3
(e) 1UP :ON
-----:
-----2P PLAY MODE-----:
(f) EASY DIFFICULTY LEVEL :EASY
(g) NORMAL DIFFICULTY LEVEL :MEDIUM
(h) HARD DIFFICULTY LEVEL :HARD
(i) LIVES :3
(j) MUSIC&VOICE IN ATTRACT :YES
  
```

- 2 Hit the P1 4-direction joystick up or down to select an item to change the setting out of (a) - (j) on the above figure. The selected item is highlighted in red.

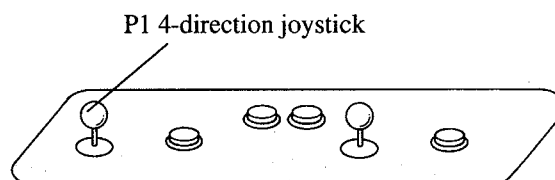

- 3 Hit the P1 4-direction joystick right or left to change the setting.

The details of the setting of each item are as follows. (The default setting out of factory is shown by the thick frame here.)

1P PLAY MODE

(a) 500m(2500ft) DIFFICULTY LEVEL(Difficulty of the game play in 500m(2500ft)mode)

EASY	MEDIUM	HARD	VERY HARD
------	---------------	------	-----------

(b) 1000m(5000ft) DIFFICULTY LEVEL(Difficulty of the game play in 1000m(5000ft) mode)

EASY	MEDIUM	HARD	VERY HARD
------	---------------	------	-----------

(c) 2000m(10000ft) DIFFICULTY LEVEL(Difficulty of the game play in 2000m(10000ft) mode)

EASY	MEDIUM	HARD	VERY HARD
------	---------------	------	-----------

(d) LIVES(The number of life in game)

1	2	3	4	5
---	---	---	---	---

(e) 1UP(Extend of life)

ON(exist)	OFF(none)
-----------	-----------

2P PLAY MODE

(f) EASY DIFFICULTY LEVEL(Difficulty of the game play in easy mode)

EASY	MEDIUM	HARD	VERY HARD
------	--------	------	-----------

(g) NORMAL DIFFICULTY LEVEL(Difficulty of the game play in normal mode)

EASY	MEDIUM	HARD	VERY HARD
------	--------	------	-----------

(h) HARD DIFFICULTY LEVEL(Difficulty of the game play in hard mode)

EASY	MEDIUM	HARD	VERY HARD
------	--------	------	-----------

*The setting in the easy difficulty mode cannot be higher than the settings for normal and hard difficulty modes.
The setting in the normal difficulty mode cannot be higher than the settings for hard difficulty modes.

(i) LIVES(The number of life in game)

1	2	3	4	5
---	---	---	---	---

ATTRACT MODE

(j) MUSIC&VOICE IN ATTRACT(Sound played in attract mode)

YES(possible)	NO(impossible)
---------------	----------------

4 Press the P1 start switch to return to the test menu screen.

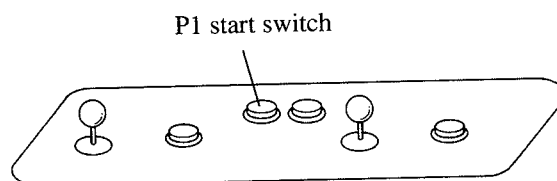

5 Perform "6-1-3 Finishing the Test Mode" (p.24) to exit the test mode.

6-6 COIN OPTIONS (Setting of play fees)

Coin options such as the credit needed to play one game play shall be set here.

- 1 Perform the procedure 1 - 4 of "6-1-2 Selecting the Adjusting Items" (p.22-23). Select "COIN OPTIONS" in 3.

The following screen is displayed.

COIN OPTIONS
<DEFAULTS IN GREEN>

(a) → **START COST:**
1 COIN TO START

(b) **CONTINUE COST:**
1 COIN TO CONTINUE

(c) **COIN CHUTE1 MECHANICAL VALUE:**
1 COIN COUNT AS 1 COIN

(d) **COIN CHUTE2 MECHANICAL VALUE:**
1 COIN COUNT AS 1 COIN

(e) **CREDIT MODE:** can not change
COMMON

(f) **COIN COUNTER:**
1 COUNTER

(g) **FREE PLAY:**
NO

SELECT : P1-LEFT or P1-RIGHT How to change the setting
EXIT : P1-START How to return to the test menu screen

- 2 Hit the P1 4-direction joystick up or down to select an item to change the setting out of (a) - (g) on the above figure. The selected item is highlighted in red.

NOTE ● Before changing the settings of (a) - (f), be sure to set OFF (g) "FREE PLAY". The settings of (a) - (f) cannot be changed if (g) is set ON.

- 3 Hit the P1 4-direction joystick right or left to change the setting.

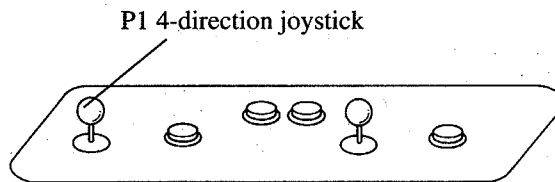

The details of the setting of each item are as follows. (The default setting out of factory is shown by the thick frame here.)

- (a) **START COST** (The number of coin(s) needed to play an initial game play)

1	2	3	4	5	6	7	8	9	COIN(S) TO START
---	---	---	---	---	---	---	---	---	------------------

- (b) **CONTINUE COST** (the number of coin(s) needed to play a continued play)

1	2	3	4	5	6	7	8	9	COIN(S) TO START
---	---	---	---	---	---	---	---	---	------------------

- (c) COIN CHUTE 1 MECHANICAL VALUE
 (The number of coin(s) to be added when the coin switch 1 activates once)
 1 COIN COUNT AS

1	2	3	4	5	6	7	8	9
---	---	---	---	---	---	---	---	---

 COIN
- (d) COIN CHUTE 2 MECHANICAL VALUE
 (The number of coin(s) to be added when the coin switch 2 activates once)
 1 COIN COUNT AS

1	2	3	4	5	6	7	8	9
---	---	---	---	---	---	---	---	---

 COIN
- (e) CREDIT MODE (Record of credit)
 Credit mode is fixed to set "COMMON" only and cannot be changed.
- (f) COIN COUNTER (Allocation of the coin counter)

1 COUNTER (Two coin switches uses one coin counter in common.)	2 COUNTERS (Each of two coin switches uses own coin counter.)
--	---

- Notes:
- The cabinet corresponding to the JAMMA VIDEO standard (JVS) with one coin counter is fixed to set "1 COUNTER" and cannot be changed to "2 COUNTERS".
 - When two cabinets corresponding to the JAMMA VIDEO standard (JVS) are linked to set networked play, it is fixed to set "2 COUNTERS" and cannot be changed to "1 COUNTER".

- (g) FREE PLAY (Setting of free play)

YES (coins needed)	NO (no coins)
--------------------	---------------

- 4** Press the P1 start switch to return to the test menu screen.

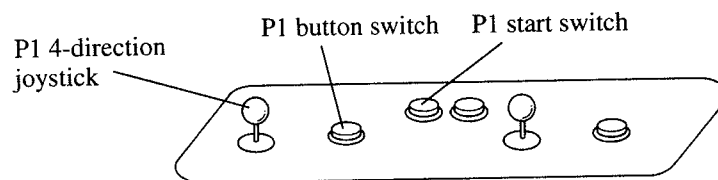

- 5** Perform "6-1-3 Finishing the Test Mode" (p.24) to exit the test mode.

6-7 A.D.S. (Checking the data on playing results in the past)

The data on playing results in the past such as the total playing time can be checked here.

- 1** Perform the procedure **1** - **4** of “6-1-2 Selecting the Adjusting Items” (p.22-23). Select “A.D.S.” in **3**.
- 2** Press the P1 start switch to return to the test menu screen.

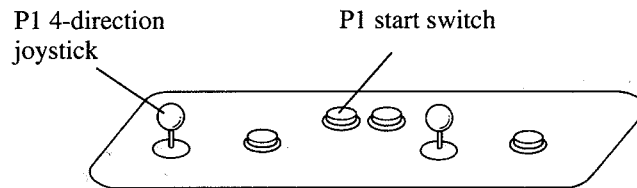

- 3** Perform “6-1-3 Finishing the Test Mode” (p.24) to exit the test mode.

6-8 DATA CLEAR (Clearing various data, initializing to default settings)

The data saved even after the power is turned off can be erased or initialized to the default value as factory-setting. This "DATA CLEAR" function is used to erase the data or initialize it.

- 1** Perform the procedure **1** - 4 of "6-1-2 Selecting the Adjusting Items" (p.22-23). Select "DATA CLEAR" in **3**.

The following screen is displayed.

DATA CLEAR

(a)	CANCEL	Return to the test menu screen
(b)	A.D.S DATA CLEAR	Clear the playing data only
(c)	RANKING CLEAR	Initialize the ranking data
(d)	SET DEFAULTS ALL OPTIONS	Set the value of all the options to default
(e)	ALL CLEAR	Clear all the data recorded

EXECUTE : BUTTON1
 EXIT : START

How to execute
 How to return to the test menu

- 2** Hit the P1 4-direction joystick up or down to select an item to erase or initialize the data out of (b) - (e) on the above figure. The selected item is highlighted in red.

P1 4-direction joystick

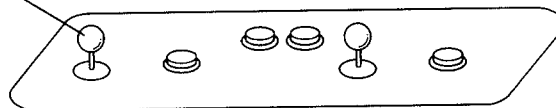

What to be executed	Item displayed on the screen
(1) Erase only the A.D.S. data (Ref. "6-7 A.D.S." on p.39)	A.D.S. CLEAR
(2) Initialize the ranking data, such as high score, to default value as factory-setting.	RANKING CLEAR
(3) Initialize the values of all the options set in the test mode (Ref. "6-2 DISPLAY TEST" on p.24 through "6-7 A.D.S." on p.39) to default values as factory-setting.	SET DEFAULTS ALL OPTIONS
(4) Execute all the (1) (2) and (3) together at the same time.	ALL CLEAR

- 3** Press the P1 button switch 1 to execute the selected item.
- 4** Do either one of the following procedure to return to the test menu screen.
 - Press the P1 start switch.
 - Hit the P1 4-direction joystick up or down to select “CANCEL” on the screen and then press the P1 button switch 1.

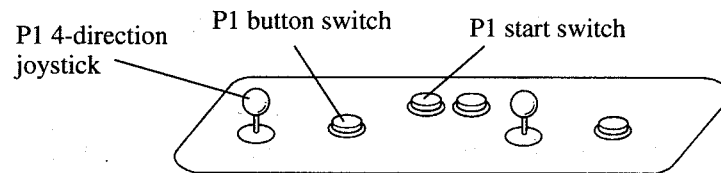

- 5** Perform “6-1-3 Finishing the Test Mode” (p.24) to exit the test mode.

7. OPERATION



WARNING :

- Should any off-flavor or noise occur, turn OFF the power switch of the cabinet immediately and stop operation. Then unplug the power cord from an electrical outlet and contact your distributor. If the machine is kept operating without solving the trouble, it may cause an electrical shock or fire.
- If you have to touch the PC board during operation, refer to “8. INSPECTION & CLEANING, TROUBLESHOOTING” on p.45.
- Make sure that installing and connecting were conducted in accordance with the instructions and the procedure specified in this operation manual (Ref. “5. Installing and Connecting” on p.9) before operation. Otherwise it may cause a fire, electrical shock or machine trouble.

7-1 Persons Not Recommended to Play



CAUTION :

- To ensure the safety of players, those who
 - are not feeling well;
 - are injured on the arms or hands;
 - are under the influence of alcohol;are not recommended to play this game.

7-2 Restrictions When Operated



WARNING :

- This product is designed for indoor use only. Do not operate this product outdoors. It may cause a fire or electrical shock.

◀ NOTES

- Observe the restrictions described under “2. SPECIFICATIONS” on p.6. Otherwise it may cause breakdown or malfunction.
- Do not operate this product in areas:
 - with direct water contact;
 - with high humidity;
 - with much dust;
 - near heating systems;
 - where a drastic change in temperature might cause dew condensation;
 - subject to vibration;
 - near inflammable or volatile substance;
 - near strong magnetism or radio source.

It may cause breakdown or malfunction.

7-3 How to Play

How to play the game and various techniques to be used are printed on A sticker, B sticker, and the title sheet.

8. INSPECTION & CLEANING, TROUBLESHOOTING

- To be serviced by a qualified service technician only -

8-1 Inspection & Cleaning



WARNING :

- Unplug the power cord of the cabinet from an electrical outlet before conducting inspection or cleaning. Otherwise an electrical shock may happen.
- Do not conduct any works with wet hands. It may cause an electrical shock.

Be sure to conduct a regular inspection and cleaning according to the following table so that the "Mr. DRILLER" game is played in good condition.

	Time	Description	Reference	Notes
Regular inspection	Every month	Check that the PC board is fixed and connected firmly. It might loosen due to the vibration during the game play, and the operation in such conditions may cause breakdown or malfunction.	5. INSTALLING AND CONNECTING (p.9)	To be serviced by a qualified service technician only.
		Check that the cabinet, harness, cables do not touch the PC board. If operated with such contact conditions, it may cause breakdown or malfunction.	5. INSTALLING AND CONNECTING (p.9)	To be serviced by a qualified service technician only.
	Every six months	Test the display, switches, and sound.	6-2 DISPLAY TEST (p.24) 6-3 SWITCH TEST (p.32) 6-4 SOUND TEST (p.33)	
		Clean the PC board. A foreign substance or dust on the PC board may cause breakdown or malfunction.		To be serviced by a qualified service technician only.

- NOTES**
- A service technician should not be charged electricity when touching the PC board. Static electricity may cause the product breakdown or damage.
 - Clean the product using a static-electricity-free cleaning equipment such as a brush for an OA equipment. The IC on the PC board may be damaged by static electricity and will not function correctly.
 - Do not clean the product using the liquid such as water or detergent. Otherwise it may cause the product breakdown or damage.
 - Do not attempt to perform conductivity test using a multi-meter. The IC of the PC board may be damaged even by the internal voltage of a multi-meter, and may not function correctly.
 - Do not replace the built-in batteries. Otherwise breakdown or damage of the product may happen.

8-2 Troubleshooting



WARNING :

- Always unplug the power cord of the cabinet from an electrical outlet before checking this product is installed and connected on the cabinet correctly. Otherwise an electrical shock may occur.
- Should any off-flavor or noise occur, turn OFF the power switch of the cabinet immediately and stop operation. Then unplug the power cord from an electrical outlet and contact your distributor. If the machine is kept operating without solving the trouble, it may cause an electrical shock or fire.

- ◀ NOTE** ● Do not replace the built-in batteries. Otherwise breakdown or damage of the product may happen.

When this product does not operate correctly or has any trouble, check it in the following procedure.

- 1** Turn OFF the power switch of the cabinet, and unplug the power cord from an electrical outlet.
- 2** Remove any foreign substance or dust on the PC board.

- ◀ NOTES** ● A service technician should not be charged electricity when touching the PC board. Static electricity may cause the product breakdown or damage.
- Clean the product using a static-electricity-free cleaning equipment such as a brush for an OA equipment. The IC on the PC board may be damaged by static electricity and will not function correctly.

- 3** Check again that this product is installed and connected correctly to the cabinet. (Refer to the operation manual of the cabinet and “5. INSTALLING AND CONNECTING” (p.9 - 19) on this operation manual.)

- ◀ NOTE** ● Do not attempt to perform conductivity test using a multi-meter. The IC of the PC board may be damaged even by the internal voltage of a multi-meter, and may not function correctly.

- 4** Plug the power cord into an electrical outlet, and turn ON the power switch of the cabinet.
- 5** Check again that adjustment is made correctly.
(Refer to “6. ADJUSTMENT FOR OPERATION” (p.20 - 41) on this manual.)

- 6** When the trouble is not solved even after performing the procedure from **1** through **5**, turn the power OFF, unplug the power cord from an electrical outlet, and contact your distributor.

9. Disassembling, Safekeeping, Transportation

9-1 Disassembling –To be serviced by a qualified service technician only –



WARNING :

- Be sure to unplug the power cord from the electrical outlet before conducting any works. Otherwise it may cause an electrical shock.

- ◀ NOTE** ● A service technician should not be charged electricity when touching the PC board. Static electricity may cause the product breakdown or damage.

Disassemble the PC board following the procedure below.

Prepare the operation manual of the cabinet at hand.

- 1** Turn the power of the cabinet OFF and unplug the power cord from an electric outlet.
- 2** Open the door of the storage of the PC board in accordance with the operation manual of the cabinet and take out the install board on which the PC board is installed.

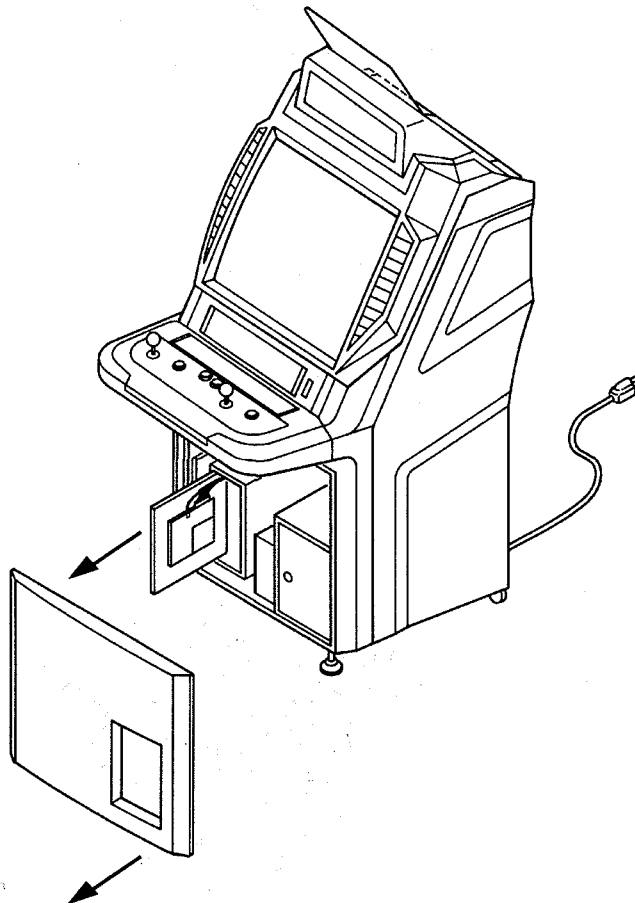

- 3** Disconnect the cables and harnesses connecting to the PC board.

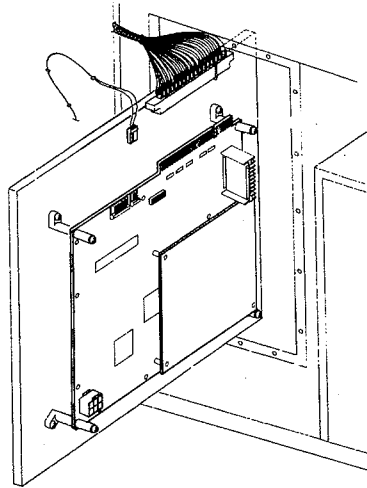

- 4** Remove the screws on the four corners of the PC board and disassemble the PC board from the install board.

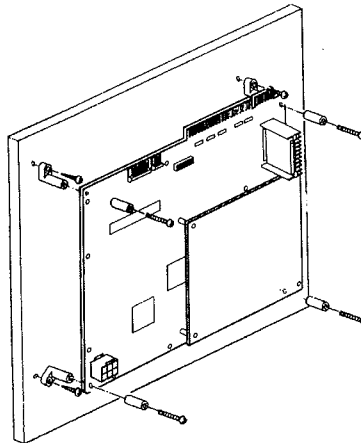

- 5** Put back the install board and close the door.

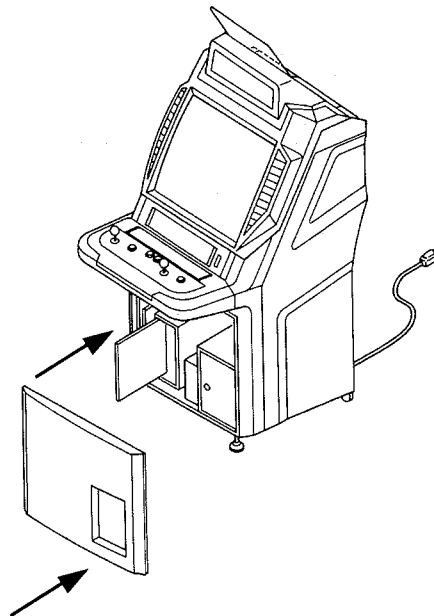

9-2 Safekeeping

After disassembled, pack this product with the packing materials attached to the product or conductive sponges and aircaps, and then keep it in a dry place with no dust. Do not put heavy stuff on it.

- NOTE** ● Do not keep this product in areas,
- where exposed to direct sunlight.
 - with direct water contact
 - with high humidity
 - with much dust
 - near heating systems
 - where a drastic change in temperature might cause dew condensation
 - with vibration
 - near inflammable substances or volatile substances.

Otherwise it may cause breakdown.

9-3 Transportation

When transporting this product for transfer, resale or repair, pack this product with the packing materials attached to the product, or conductive sponges or aircaps, and put it in a cardboard carton.

10. DISPOSAL



WARNING :

- Do not throw this product into a fire. Otherwise it may cause an explosion of lithium batteries used in the product and cause injury.
- When disposing this product, collect, transport and scrap it in accordance with law and orders.
- If entrusting others to collect, transport and scrap this product, hire specialists in each of such work.

11. REPLACEMENT PARTS LIST

The following parts are provided as replacement parts for this product.

Contact your distributor for inquiries on the replacement parts.

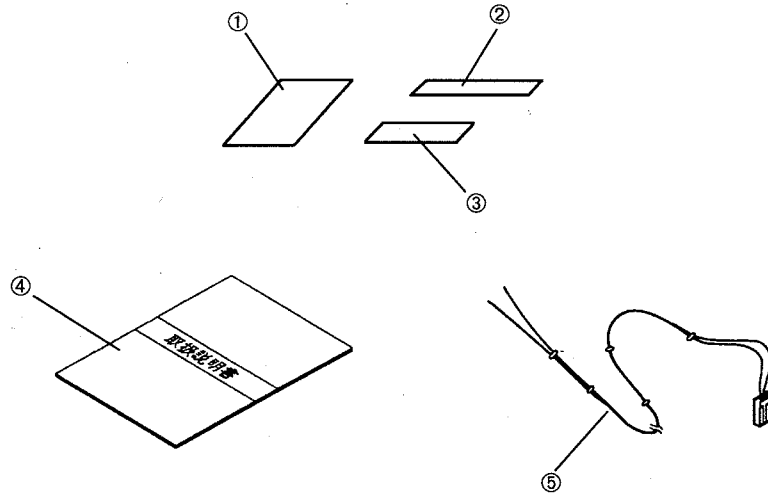

No.	Name	Quantity	Model number	Parts No.
①	Title sheet	1		499-153
②	A sticker	1		499-154
③	B sticker	1		499-155
④	Mr. DRILLER2 PC Board Operation Manual	1		499-152
⑤	Extended stereo sound connector (EI4P)	1		499-156

©NAMCO LIMITED

First edition is issued in July 2000