



**OPERATOR'S MANUAL**

**FABTEK®**

## **SAFETY**

The following topics should be carefully studied to ensure maximum reliability and safety for both serviceman and customer. Shock Hazard: The high voltage present on the monitor may be very dangerous. Extreme caution must be used when working with or around the monitors. Be certain that the grounding strap is attached to the monitor frame. The picture tube in the monitor is also a hazard and should be handled with care. Do not strike, scratch, or subject the tube to more than moderate pressure as it may implode causing serious injury from flying glass. Be certain that the control panel, power supply, monitor, and coin door are all properly grounded to the ground wire inside the line cord. Do not remove the ground prong off of the plug end.

### **FABTEK®**

16710 79<sup>th</sup> Avenue NE #104  
Redmond, WA 98052  
(425) 881-0990  
FAX (425) 881-6503

### **FOR SERVICE CONTACT:**

Your authorized Fabtek® Distributor

or

### **SUMMIT SERVICE**

2274 University Avenue  
St. Paul, MN 55114  
(612) 645-9077

## **WARRANTY REPAIRS**

Fabtek PCBs have a 90 day warranty from date of shipment. This includes all failures except those caused by the installer such as miswiring.

All PCBs must be returned by an authorized Fabtek distributor. A Return Material Authorization number must be obtained from Summit Service prior to returning material. A Purchase Order number must also be given to Summit Service at this time. The package must be clearly marked with the RMA number.

## \* CASSETTE REPLACEMENT \*

You are able to exchange the cassettes on this type of board. When replacing cassettes, please follow the procedure set out below:

1. Turn off the power.
2. Remove the cassette. When removing a cassette please pull it out straight.
3. Insert the new cassette. When inserting a new cassette, please place a magazine or the like under the mother-board to prevent it from being bent. Please pay attention to the direction of the cassette before attempting to insert it. (The cassette will not fit into the sockets if you try to place it in backwards.)

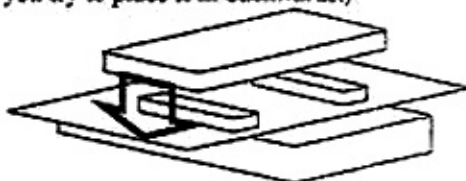

4. Please place JP1 into the position for replacing cassettes.
5. When the power is turned on, data transmission will start to occur, so please leave the board alone and wait for a while (it takes approximately 10 minutes). If an error message occurs, check such things as the connection to the 12V power source or the actual voltage of the power source. (Please use a stable 12V voltage power source.)
6. When the data transmission has completed, please turn the power off and return JP1 to its normal position.
7. Turning the power back on will start the game operating.

### NOTES OF CAUTION

1. Always make sure the power is turned off before installing or removing PC boards or their cassettes.
2. Removal of the serial number sticker affixed to this board, or alteration of the board without consent, will result in loss of subjectivity to warranty period.
3. Please use an edge connector that conforms to the JAMMA standard. Alterations such as scraping off the edge section of the PC board are a cause of malfunction, so please desist from such actions.
4. The circuits have a battery backed memory system. Please refrain from carrying out conductivity inspections with such tools as circuit testers as these can cause short circuits.
5. When transporting PC boards, please wrap them in sponge rubber or bubble wrap and place them in cardboard boxes. Take care to prevent exposure to strong shocks or jolts.
6. When replacing sub-boards, place a support such as a magazine or a book under the mother-board to prevent it from being bent.
7. Please use a stable 12V power source.
8. It is not unusual for there to be some noise in the sound at start-up.
9. Turning the volume up to maximum when set to stereo output may cause the sound to become strange, but this is not a malfunction. If this occurs, either turn down the volume or, change the 12V power source by increasing the current to about 2 AMPS. (i.e. change the power supplies current not the voltage.)

## \* TEST MODE \*

Turning the test-switch ON while the game's screen is being displayed will take you into test mode with the test menu being displayed on the screen instead. Please use the cabinet's test switch. (Refer to the table of connector's to see how to link the switch to this board.) Pushing up and down on 1P's 8-way lever allows you to move to an option, pushing button 1 will select that option and change to that option's test screen.

### TEST MODE SCREEN

#### TEST MODE

EXIT  
GAME SETTING  
INCOME  
I/O TEST  
MONITOR TEST  
ADJUST TIMER  
RESET SETTINGS

finishes test mode.

takes you to GAME SET UP menu screen.

takes you to the INCOME'S DATA screen (displays a week's income figures.)  
changes to a test screen for each switch.

turns to a screen for adjusting the monitor.

turns to a screen for adjusting the timer (It synchronize the PC board's clock).

takes you to the RESET SETTINGS screen.

### GAME SETTINGS SCREEN

#### GAME SET UP

1 CREDIT(S) / CONTINUE  
1 CREDITS(S) / SOLO START  
2 CREDIT(S) / DUAL START  
SHOOTER 1  
1 COIN (S) / 1 CREDIT(S)  
SHOOTER 2  
1 COIN (S) / 1 CREDIT(S)  
3 SHIP(S) / 1 PLAY  
DIFFICULTY (NORMAL)  
SCORE-KEEPING ON  
DEMO SOUND ON  
FREE PLAY OFF  
PLAYER SELECT  
RESTART FINAL MISSION

set the cost it takes to continue. # of credits (1-9) needed to continue

set the cost for one player start. # of credits (1-9) needed to start

set the cost for two player start. # of credits (1-9) needed to start

revise game's charges (coin slot 1).

# coins (1-9) needed per (1-9) credit (s)

revise game's charges (coin slot 2)

# coins (1-9) needed per (1-9) credits (s)

# of lives (1-6) per game

Game's difficulty level. (EASY, NORMAL, HARD, or VERY HARD)

high-score save function. (ON/OFF)

play sounds during demo. (ON/OFF)

free play mode. (ON/OFF)

CONTINUE (ON, OFF)

CONTINUE (ON, OFF)

### TIMER ADJUSTMENT SCREEN

#### ADJUST TIMER

CANCEL!  
YEAR 1995  
MONTH 6  
DAY 10  
HOUR 10  
MINUTE 10  
SET TO MEMORY!

There is an internal clock fitted on the PC board. When you adjust this clock to the right time, you can keep a proper record of the game's weekly income. Use the 8-way lever to choose the time unit you wish to adjust, push either button 1 or 2 to change that unit. When you have made all necessary adjustments, move the cursor to "SET TO MEMORY" and press button 1 to start the clock ticking. Or you can choose "CANCEL" to exit without implementing any changes.

### RESET SETTINGS SCREEN

#### RESET SETTING

EXIT  
DEFAULT GAME SETTING  
CLEAR INCOME DATA  
CLEAR SCORE RANKING

return to the TEST MODE screen

reinitialize GAME SETTINGS to the default settings.

deletes all income figures.

deletes the high-score table.



56 Pin edge-connector (JAMMA)

SOLDER SIDE	NO	NO	PARTS SIDE
GND	A	1	GND
GND	B	2	GND
+5V	C	3	+5V
+5V	D	4	+5V
	E	5	
+12V	F	6	+12V
	H	7	
COIN COUNTER 2	J	8	COIN COUNTER 1
	K	9	
SPEAKER (-)	L	10	SPEAKER (+)
	M	11	
VIDEO GREEN	N	12	VIDEO RED
VIDEO SYNC	P	13	VIDEO BLUE
SERVICE SW	R	14	VIDEO GND
	S	15	TEST SW
COIN 2	T	16	COIN 1
2P START	U	17	1P START
2P UP	V	18	1P UP
2P DOWN	W	19	1P DOWN
2P LEFT	X	20	1P LEFT
2P RIGHT	Y	21	1P RIGHT
2P PUSH 1 (Rapid Fire)	Z	22	1P PUSH 1 (Rapid Fire)
2P PUSH 2 (Bomb)	a	23	1P PUSH 2 (Bomb)
	b	24	
	c	25	
	d	26	
GND	e	27	GND
GND	f	28	GND

- JAMMA STANDARD
- VERTICAL SCREEN

8 Way Joystick

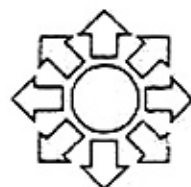

Fire  
PUSH 1



Bombs  
PUSH 2



Control Panel layout

- power source      +5V    5A  
                             +12V   1A

(Please use a power source that provides as stable a power supply as possible)

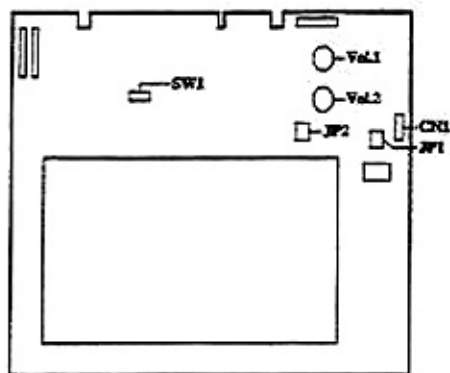

Control	Mode	Function
Vol. 1	MONAURAL STEREO	controls the volume controls the left-side volume
Vol. 2	MONAURAL STEREO	not used controls the right-side volume (The sound may become strange if you turn the volume to maximum in stereo mode.)

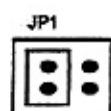

Normal

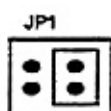

Change Cassette

**JP1** Only when replacing cassettes should the power be turned on with JP1 placed in the change cassette position. If you are replacing cassettes then, after following the messages displayed on the screen and turning off the power. *Please be sure to return JP1 to its normal position.*

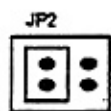

Stereo

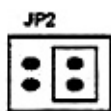

Monaural  
(Default Settings)

**JP2** Used to change between Stereo and Monaural sound modes.

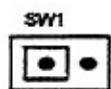

Normal  
(Default Settings)

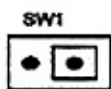

Reversed

**SW1** Reverses the screen's display

**CN1**

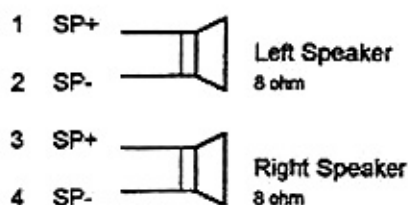

**CN1** 4 Pin connector for stereo sound output.  
(Connect each pin totally separate from the others.)

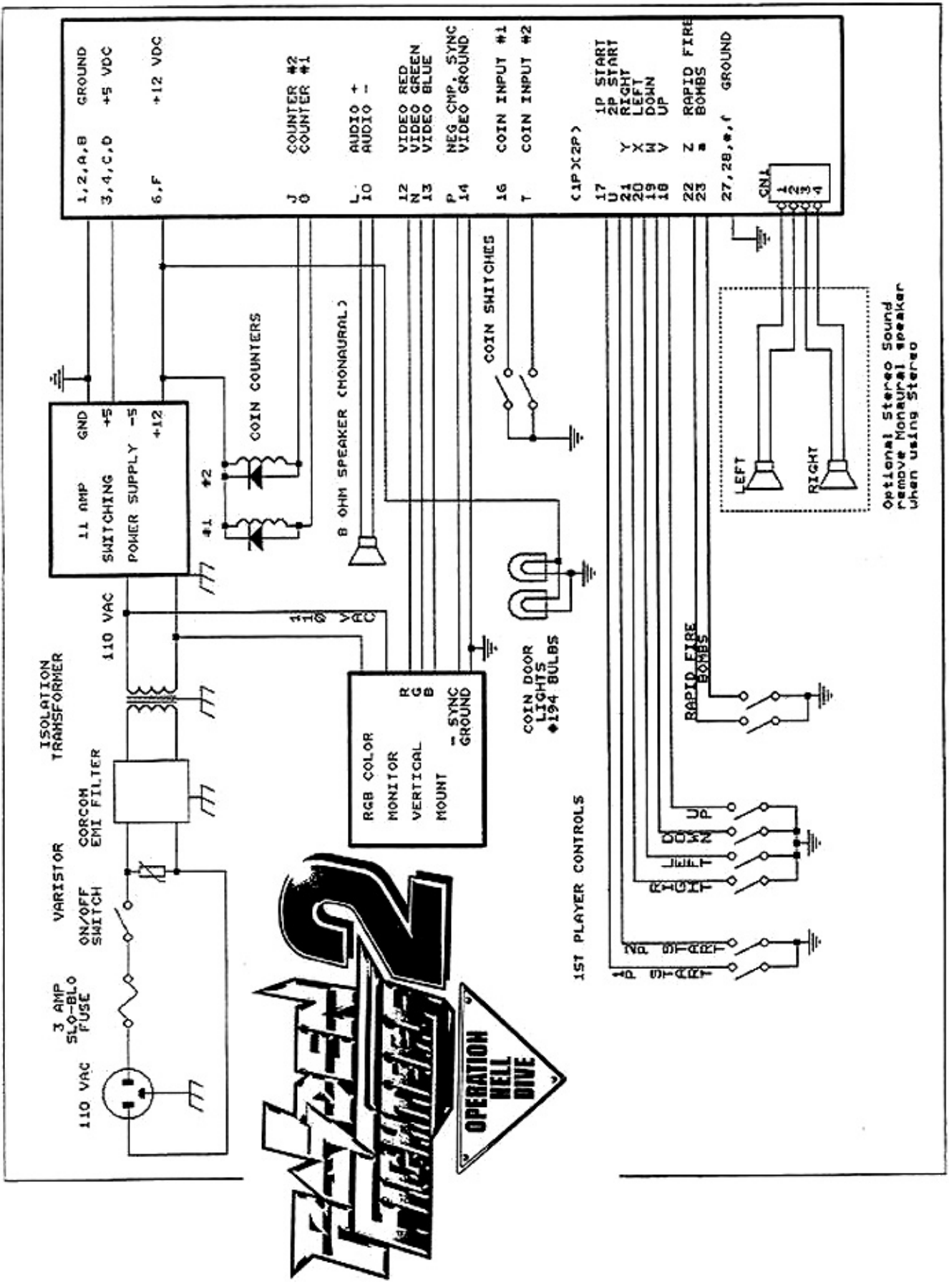

1,2,A,B GROUND  
 3,4,C,D +5 VDC  
 6,F +12 VDC

J  
0 COUNTER #2  
 COUNTER #1  
 L  
10 AUDIO +  
 AUDIO -  
 N  
12 VIDEO RED  
 13 VIDEO GREEN  
 VIDEO BLUE  
 P  
14 NEG CMP. SYNC  
 VIDEO GROUND  
 T  
16 COIN INPUT #1  
 COIN INPUT #2

C1P>C2P>  
 17 1P START  
 U 2P START  
 24 RIGHT  
 X LEFT  
 20 DOWN  
 19 UP  
 W  
 V  
 18  
 22 Z RAPID FIRE  
 23 B BOMBS  
 27,28,\*,† GROUND

GN1  
 1  
 2  
 3  
 4

ISOLATION TRANSFORMER

VARIATOR  
 ON/OFF SWITCH  
 CORCOM EMI FILTER

3 AMP SLO-BLO FUSE  
 110 VAC

11 AMP SWITCHING POWER SUPPLY  
 GND +5 -5 +12  
 #1 #2

COIN COUNTERS

8 OHM SPEAKER (MONAURAL)

RGB COLOR MONITOR  
 VERTICAL MOUNT  
 R G B  
 - SYNC GROUND

COIN SWITCHES

COIN DOOR LIGHTS  
 194 BULBS

1ST PLAYER CONTROLS

No. 1-4  
 UP  
 DOWN  
 LEFT  
 RIGHT

RAPID FIRE BOMBS

LEFT  
 RIGHT

Optional Stereo Sound  
 Remove Monaural speaker  
 when using Stereo

