



RIP CORD



MAY 1979

(C) 1979 EXIDY Inc.

CONTENTS

I. GENERAL	3
II. NORMAL OPERATION	
A. Attract Mode	4
B. Introduction Mode	4
C. Game Play	4
III. SELECTABLE OPTIONS	
A. Coinage	5
B. Jumps (Turns)	5
C. TOP THIS SCORE	5
IV. AUDIO ADJUSTMENTS	5
V. POWER SUPPLY ADJUSTMENTS	6
VI. MECHANICAL ASSEMBLIES	
A. Control Panel	7
B. To Service the D-Ring Control	8
C. To Remove the Monitor	9
D. To Remove the Logic Board	9
VII. TECHNICAL INFORMATION	
A. Logic Description and Operation	10
B. Audio Description and Operation	10
C. Diagrams, Pinout Table, and Schematics	13

ILLUSTRATIONS

Figure 1: Monitor Display	3
Figure 2: Audio Board Adjustments	5
Figure 3: Power Supply Adjustments	6
Figure 4: Control Panel	7
Figure 5: D-Ring Control	8
Figure 6: Major Internal Components	9
Figure 7: Logic Board Block Diagram	13
Figure 8: Audio Board Block Diagram	14
Figure 9: Harness Diagram	15

I. GENERAL

RIPCORD is a one or two player skill game in which each player launches a parachutist out of a plane, opens the parachute, and controls the parachutist's drift. The players score points by landing the parachutist on a scoring platform (see Figure 1).

The plane that the parachutist jumps from flies right to left across the top of the screen, at a random height. A number of helicopters fly about the screen at random. If the parachutist hits a helicopter or misses a scoring platform, he falls into the sea.

RIPCORD can be set for 3, 5, 7, or 9 jumps per game, but these jumps are not deducted until the player fails to score.

RIPCORD has three coinage options. Full instructions are displayed on screen after the player inserts his coins, and the day's high score is shown on screen. There is an optional "top this score" feature which gives a replay to the player who beats a random score.

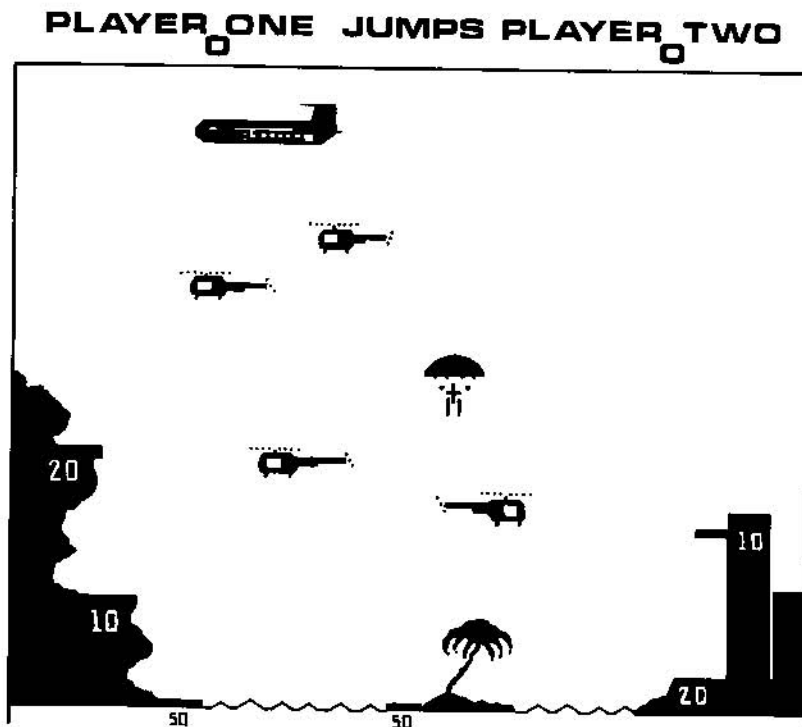

Figure 1: Monitor Display

II. NORMAL OPERATION

A. Attract Mode

When the game is first turned on, the words GAME OVER will flash on screen. Also on screen will be TODAY'S HIGH SCORE followed by a score which changes with each new higher score attained throughout the day. When the game is turned off, the high score is reset to zero.

Also displayed on screen, at the operator's selection, will be one of the following:

Two Player - 1 Coin
or
One Player - 1 Coin
Two Player - 2 Coin
or
One Player - 2 Coin
Two Player - 4 Coin

RIPCORD also has a credit counter so that a player can buy a number of games in advance.

While in the attract mode (no credits, no game in progress) the game plays automatically.

B. Introduction Mode

When a player deposits a coin, the following message comes on screen:

PUSH JUMP BUTTON
PULL D RING TO OPEN PARACHUTE
JUMP UNTIL TARGET IS MISSED
TARGETS INDICATE SCORE

CREDITS N

TOP THIS SCORE FOR CREDIT

M

Here, N is the number of games in the credit counter, and M is a random score used by the "top this score" feature. At the operator's

option, RIPCORD awards one extra game to any player who matches or exceeds the score M.

C. Game Play

When the START button is pressed (after coinage), a fanfare tune alerts the player that the game has begun, and the number of jumps (turns) per player is shown at the top center of the screen. This number is operator selectable to 3, 5, 7, or 9.

When the fanfare ends, the plane flies on screen. To launch the parachutist out of the plane, the player must push the JUMP button on the control panel. To open the parachute, he must pull the D-RING at the left of the video screen. After opening the chute, he can control the parachutist's drift with the DRIFT control knob on the control panel.

Each player tries to land the parachutist on one of the scoring platforms, using the DRIFT control. If successful, he continues jumping until he finally misses a platform. If he scores twice in a row, he is eligible for a BONUS SCORE: the next jumps score ten times the normal amount. This bonus remains in effect until he misses a platform.

If a player scores several times in a row, the helicopters become more active and interfere with the parachutist. This tests the player's skill, since it is difficult to build up high scores.

III. SELECTABLE OPTIONS

RIPCORD has three switch selectable options. These are controlled by a seven segment DIP switch located on the main logic board at position 14A (see Figure 4, item 8). This switch is accessible from the front of the game through the coin door.

Following are the options and the switch settings for their selection:

A. Coinage	switch 4	switch 5
2 Player - 1 Coin	ON	ON
1 Player - 1 Coin	ON	OFF
2 Player - 2 Coin		
1 Player - 2 Coin	OFF	ON
2 Player - 4 Coin		

B. Jumps (Turns)	switch 6	switch 7
3 Jumps	ON	ON
5 Jumps	ON	OFF
7 Jumps	OFF	ON
9 Jumps	OFF	OFF

C. TOP THIS SCORE	switch 3
Credit awarded for topping score	OFF
Credit <u>not</u> awarded for topping score	ON

IV. AUDIO ADJUSTMENTS (See Figure 2)

CHUTE OPEN -- 2 pots:
R60=low frequency
R39=high frequency

SPLASH -- 1 pot:
R29=volume

SCREAM -- 3 pots:
R47=frequency
R2 =modulation
R49=volume

WHISTLE -- 1 pot:
R16=volume

MUSIC -- 1 pot:
R63=volume

TONE -- 1 pot:
R65=tone control

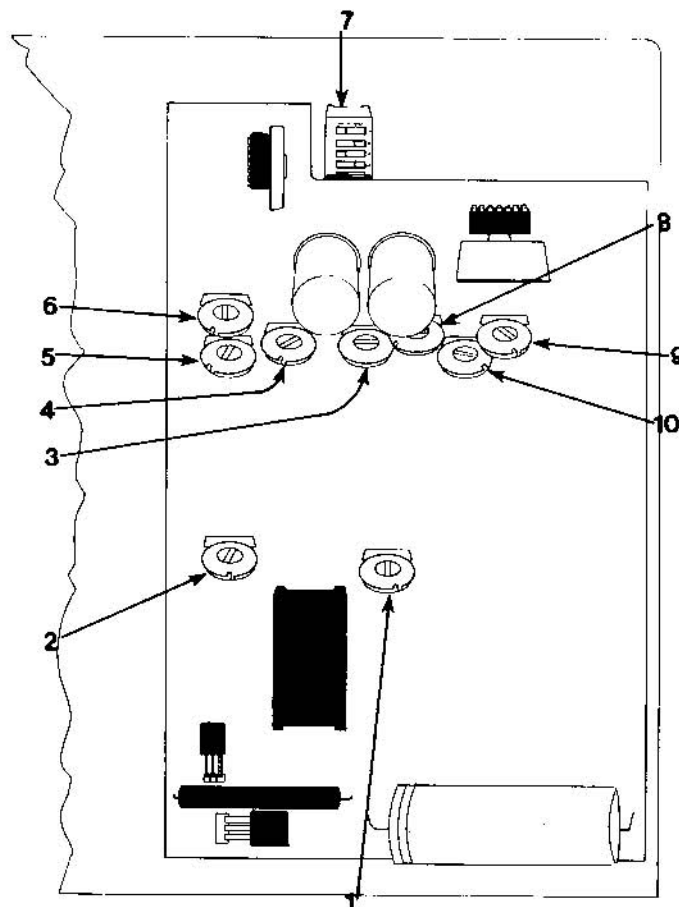

Figure 2: Audio Board Adjustments

- | | |
|------------------|---------------|
| 1 R16 WHISTLE | 6 R65 TONE |
| 2 R63 MUSIC | 7 DIP switch |
| 3 R39 CHUTE OPEN | 8 R49 SCREAM |
| 4 R29 SPLASH | 9 R2 SCREAM |
| 5 R60 CHUTE OPEN | 10 R47 SCREAM |

V. POWER SUPPLY ADJUSTMENTS

1. Connect a voltmeter to the +5 and ground traces on the logic board.
2. Adjust the power supply potentiometer for $+5.0 \pm .1$ VDC (see Figure 3).

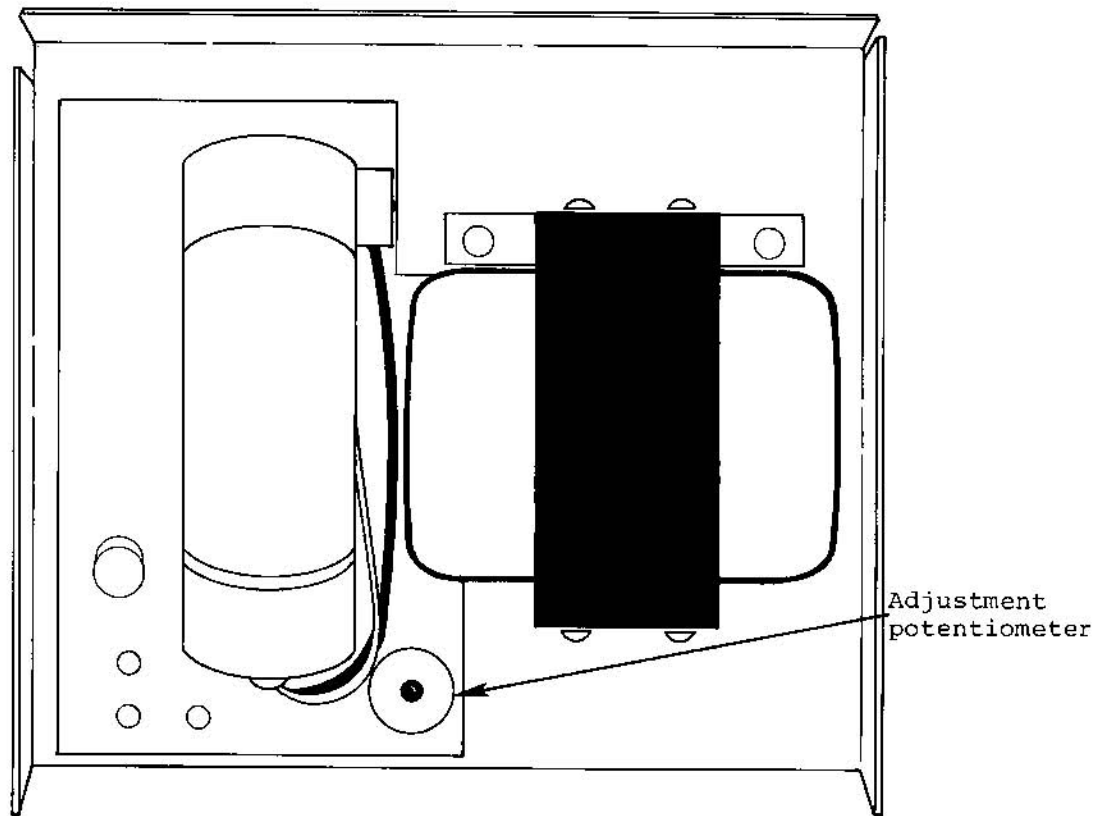

Figure 3: Power Supply Adjustments

VI. MECHANICAL ASSEMBLIES

A. RIPCORD Control Panel (see Figure 4)

The RIPCORD control panel is a single metal plate with four welded mounting studs. One potentiometer and three pushbutton switches are mounted on the panel and connected to the harness with fast-on terminals. The panel is finished with flat black enamel; if necessary, retouch with flat black spray paint.

To service the control panel:

1. Open the coindoor.
2. Reaching up through the coindoor, remove the wingnuts from the four welded corner studs that hold the control panel down.
3. Lift the control panel up from the cabinet and set it on edge, so that you can reach its underside.
4. Check all terminal connections to the pushbuttons and the potentiometer.

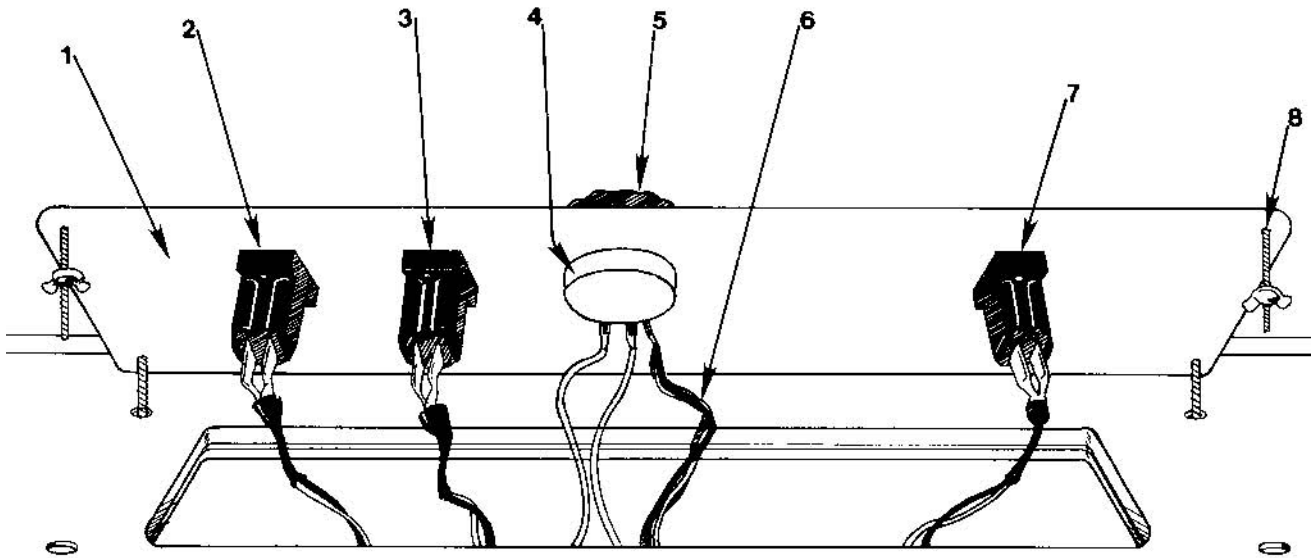

Figure 4: Control Panel

- | | | | |
|---|----------------|---|----------------------------------|
| 1 | Steel panel | 5 | Drift control knob |
| 2 | 1 player start | 6 | Harness |
| 3 | Jump button | 7 | 2 player start |
| 4 | Potentiometer | 8 | Welded corner stud with wing nut |

B. To Service the D-Ring Control

The microswitch and lever spring are easily accessible through the back of the cabinet. You should not have to remove the control for service, but if you do, follow these steps:

1. Unplug the power cord.
2. Open and remove the back door.
3. The triangular D-ring is held together by a grooved pin; the joint is covered with a length

of shrink tubing (see Figure 5). Slide the shrink tubing aside and drive out the grooved pin; then pull the D-ring open and remove it from the lever.

4. Remove the front plastic panel from the cabinet by popping it out of its moldings.
5. From the front of the cabinet, remove the two hex-head screws which hold the control in place.
6. From the back of the cabinet, remove the control.

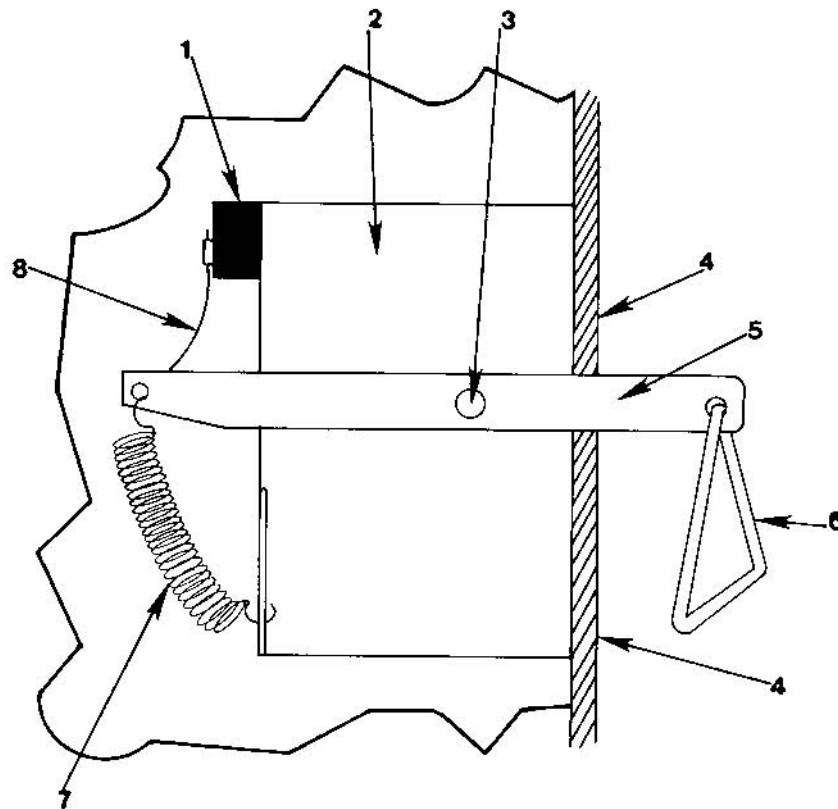

Figure 5: D-Ring Control

- | | |
|--------------------|----------------|
| 1 Microswitch | 5 Lever |
| 2 Mounting bracket | 6 D-ring |
| 3 Pivot bolt | 7 Lever spring |
| 4 Mounting screws | 8 Tripwire |

C. To Remove the Monitor

1. Unplug the power cord.
2. Open and remove the back door.
3. Unplug the harness connector from the monitor.
4. Remove the four bolts from the monitor chassis flange mounts.
5. Lift the monitor up and slide it out of the cabinet.

D. To Remove the Logic Board

1. Unplug the power cord.
2. Open and remove the back door.
3. Clip the plastic tie wraps which hold the board in its rack.
4. Disconnect the edge connector from the board.
5. Slide the board out of its rack.

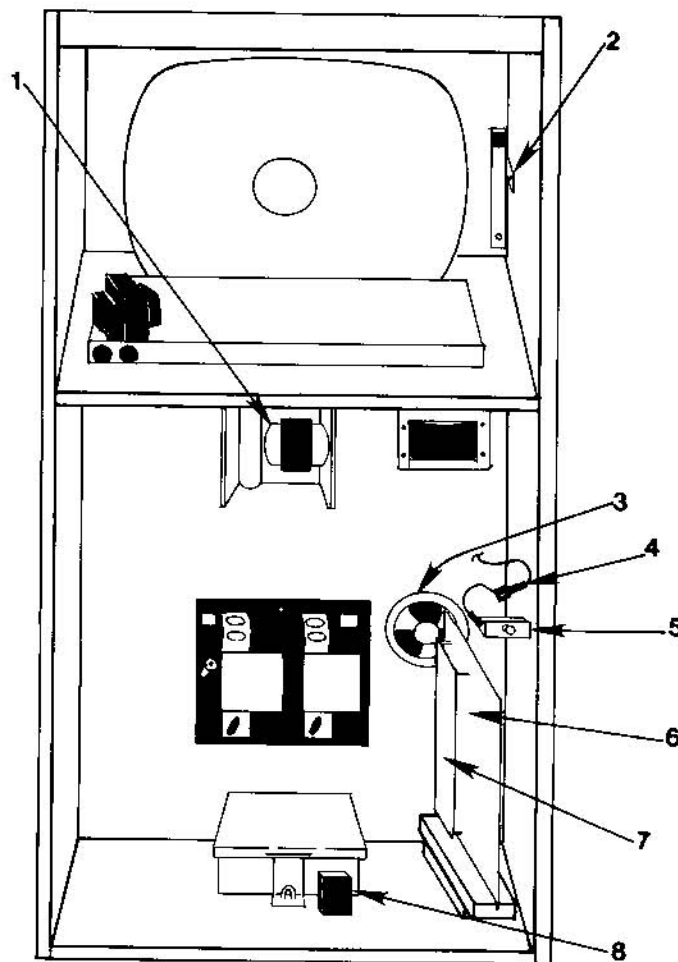

Figure 6: Major Internal Components

- | | |
|------------------------------------|--------------------|
| 1 Power supply
(see Figure 3) | 4 Fuse |
| 2 D-ring control
(see Figure 5) | 5 Interlock switch |
| 3 Speaker | 6 Logic PC board |
| | 7 Audio PC board |
| | 8 Coin counter |

VII. TECHNICAL INFORMATION

A. Logic Description and Operation

RIPCORD is a microcomputer game which uses the 6502 central processor unit. (For more information on this processor, refer to MOSTEK publication #6500-10A, MCS 6500 Microcomputer Family Hardware Manual.)

This processor is unique in that it does not have a separate input/output structure, but treats all I/O as if it were an area of memory. Memory is mapped as follows:

FFF8-FFFF	Interrupt and reset vectors
F000-FFF7	Program storage (PROM)
D000	Drift control and Interrupt reset
C000	Option switches (input)
A000	Control switches (input)
8000	Parachutist rotation and audio control bits (outputs)
4000-43FF	Screen RAM
3000	Parachutist horizontal position (controls)
2000	Parachutist vertical position (controls)
1000-1FFF	Program storage (PROM)
0100-01FF	Stack RAM
0000-00FF	Base page RAM

Base page RAM holds variables while the game program is running; the stack RAM holds return addresses and important data during subroutines. The program storage PROM holds the program which controls the operation of the game.

The screen RAM consists of 1024 bytes (8-bit words) of read/write memory. When not being addressed by the processor, this RAM is scanned by main timing, to display a 32 x 32 matrix of squares on the screen. The data stored in the screen RAM is then used to select one of 256 images from the screen ROM (each image is 8 elements wide and 8 lines tall). Note that the processor never addresses the screen ROM directly.

The 8 x 8 images selected from screen ROM fit together to form the display on screen. An alphanumeric character takes only one 8 x 8 image to display, while a helicopter, the plane, and the parachutist are each made up of several images.

Example:

To store the letter "X" in the upper left corner of the screen, the processor would write 29H in memory location 4000H.

The same circuitry that generates sync and scans the screen RAM also generates the horizontal and vertical lines which form the box around the screen display.

The parachutist is generated by two sets of counters (horizontal and vertical) which are used to position the figure on screen. The outputs of the counters, along with the rotation information in 8000H, are fed to the parachutist PROM to form the parachutist's image. The processor controls the parachutist by preloading the counters to the desired position during vertical sync.

The processor reads data from the switches by gating the data from the control or option switches onto the data bus when the appropriate address is selected.

The drift control is an analog to digital converter which the processor reads to determine the horizontal position of the parachutist.

B. Audio Description and Operation (see Figure 8)

The audio board is powered by +5 VDC from the video monitor and +15 VDC developed on the audio board itself. The AC power source for the +15 VDC comes from an external transformer which steps down the 115 VAC line voltage.

The audio board contains the following circuits:

- * +15 VDC power supply
- * audio amplifier
- * white noise generator
- * chute open sound generator
- * splash sound generator
- * scream sound generator
- * whistle sound generator
- * music input
- * video inversion driver

Following are brief descriptions of these circuits:

The +15 VDC Power Supply

The first stage of the +15 VDC supply is a full wave rectifier which converts the input 35 VAC (center-tapped) to approximately +25 VDC. This later DC voltage is not critical, however, and may vary from board to board or transformer to transformer.

The second stage is a self-contained 3-lead regulator chip (LM 340T or equivalent) which converts the +25 VDC to +15 VDC. This +15 VDC source feeds most audio circuits, and the base of transistor Q1. This source is a relatively low current supply, so pass transistor Q1 provides a higher current at +15 VDC for the audio amplifier chips (LM 380N or equivalent). Transistor Q1 is configured as an emitter follower, so the emitter voltage will equal the regulated +15 VDC minus approximately .7 VDC (the normal drop across the base-emitter junction for a silicon transistor at or near saturation).

The Chute Open Sound Generator

This sound is triggered by a negative-going TTL pulse from the logic board.

The circuit comprises two phase shift oscillators, one tuned at a lower frequency than the other. The transistors in these oscillators (Q7 and Q12) normally receive no base current, so the circuits do not oscillate.

Example:

The base of Q12 has no current path toward a positive voltage, since the anode of CR17 is pulled to ground by an open collector gate.

When signal 5 CHUTE OPEN drives the input of the gate low, the output is allowed to swing high, forward biasing diode CR17 and creating a current path through R62 to +5 VDC. This turns on the oscillator and charges capacitor C31. When signal 5 CHUTE OPEN disappears, diode CR17 once more is reverse biased, shutting off the current path. Since C31 is still charged, Q12 has base current for a period determined by the RC combination C31, R53.

Note that the input diodes (CR17 and CR10) for both oscillators have a common anode. Both circuits operate identically and simultaneously, but due to the fact that the RC combination for each oscillator is different, one (the low frequency oscillator) stays on longer than the other, after the input signal is removed.

Diodes CR11 and CR18 provide output isolation, while allowing the signals to pass on to the volume pots and then to the audio input bus.

The Splash Sound Generator

The Splash sound is triggered by a negative going TTL pulse from the logic board. The input structure is similar to the input of the Chute Open sound generator, in that transistor Q6 receives no base current until the incoming signal 5 SPLASH forward biases diode CR7, creating a base current path toward +15 VDC, and simultaneously charging capacitor C15. When the input signal is removed, diode CR7 is once more reverse biased,

leaving the charged C15 to keep the circuit on for a period determined by the RC combination C15, R24.

This circuit, however, does not oscillate. It merely amplifies the white noise previously generated. Thus, it is like an amplifying switch with a small turn-off delay. A diode in the collector of Q6 provides output isolation as in the Chute Open circuit.

The Scream Sound Generator

The scream sound is enabled by a TTL low level input from the logic board. This generator consists of a voltage controlled oscillator (used as a tone generator) and an amplitude modulator used to shape the sound volume.

When there is no input signal, transistor Q11 is saturated, thus holding U4 pin 5 (the input to the VC) relatively low and U5 pin 2 (the control input to the amplitude modulator) relatively high. This voltage at U5 pin 2 holds the output OFF.

Note that one end of a 68K resistor is tied to the base of Q11 and the other end is tied to the output of an open-collector gate. Given a TTL low level on the input of this gate, the output drives toward ground, thus making the 68K resistor effectively the bottom part of a resistor divider on the base of Q11.

This would immediately rob Q11 of most of its base current and cause the collector voltage to rise, if not for the 6.8 uF capacitor in the upper half of the divider. This capacitor takes time to discharge, and thus the collector voltage rises gradually. This changes the VCO frequency gradually from low to high.

Since the emitter voltage is the amplitude control input to U5, this also enables the output of the modulator U5 in the same manner (except that a descending voltage increases the output amplitude). U9 provides

additional modulation; R2 is the modulation control.

The duration of the input signal 5 SCREAM determines the duration of the scream sound directly. The output is fed directly to the audio input bus.

The Whistle Sound Generator

The Q4 - U10 circuit generates the whistle sound in much the same way that the Q11 - U4 circuit generates the scream sound. R16 is the volume control.

The Music Input

The music is generated entirely by the microprocessor on the logic board, out of software. The input on the audio board simply consists of an isolation and volume control network, prior to passing the signal to the audio bus.

The Video Inversion Driver

This circuit is used only in cocktail table models of RIPCORN, where the video display must be turned over in order for a player on either side of the table to see an upright picture when it is his turn to play. The circuit is a single D type flip-flop driving a transistor (MJE 182). When this transistor is turned on the collector drives toward ground, thus supplying the yoke relay with the ground it needs to energize and reverse the yoke leads in the video monitor.

The flip-flop U2 is set by a negative going TTL pulse from the logic board to U2 pin 2; this inverts the picture. U2 is reset by a negative going pulse from the logic board to pin 13.

C. Diagrams, Pinout Table, and Schematics

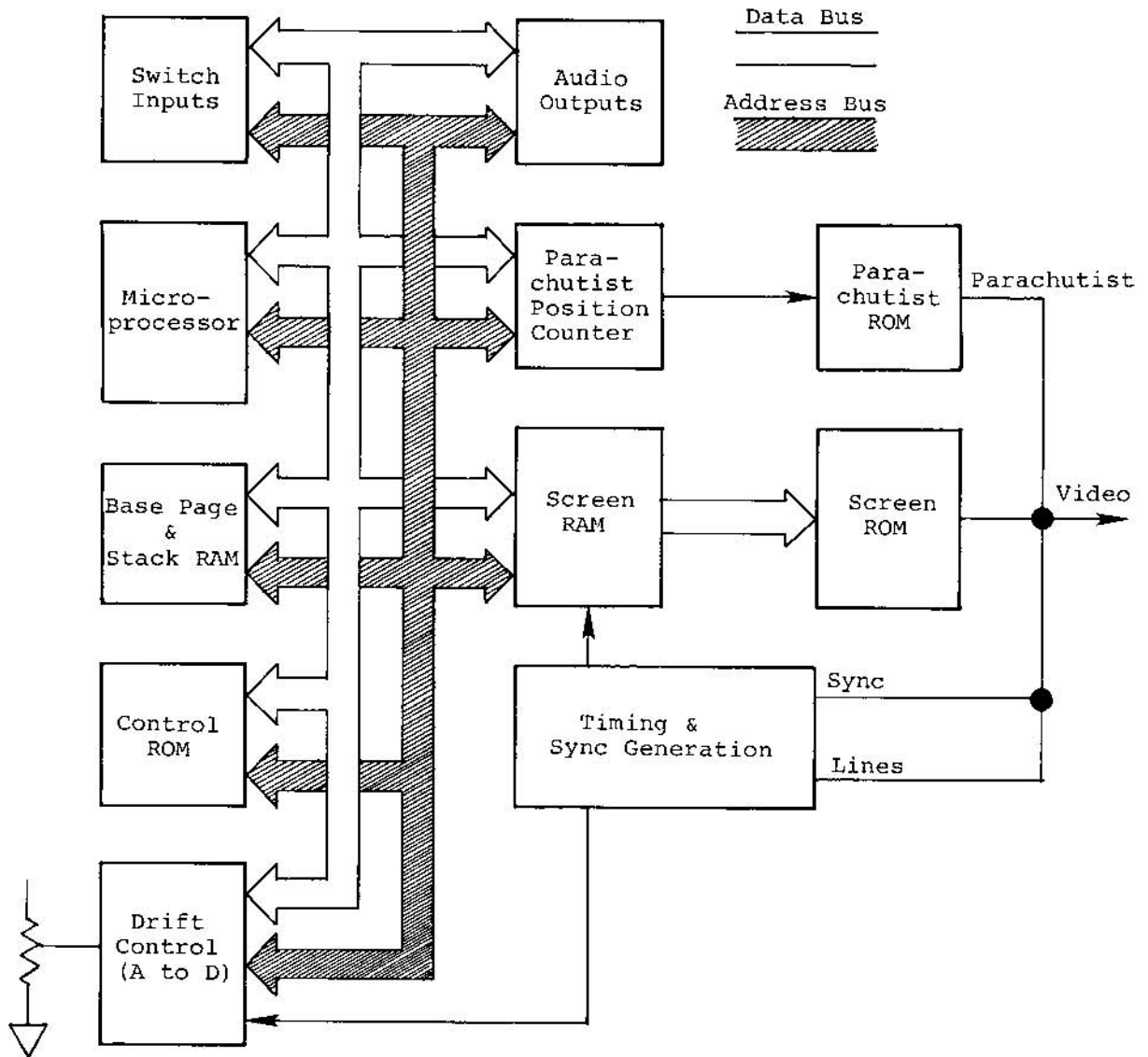

Figure 7: Logic Board Block Diagram

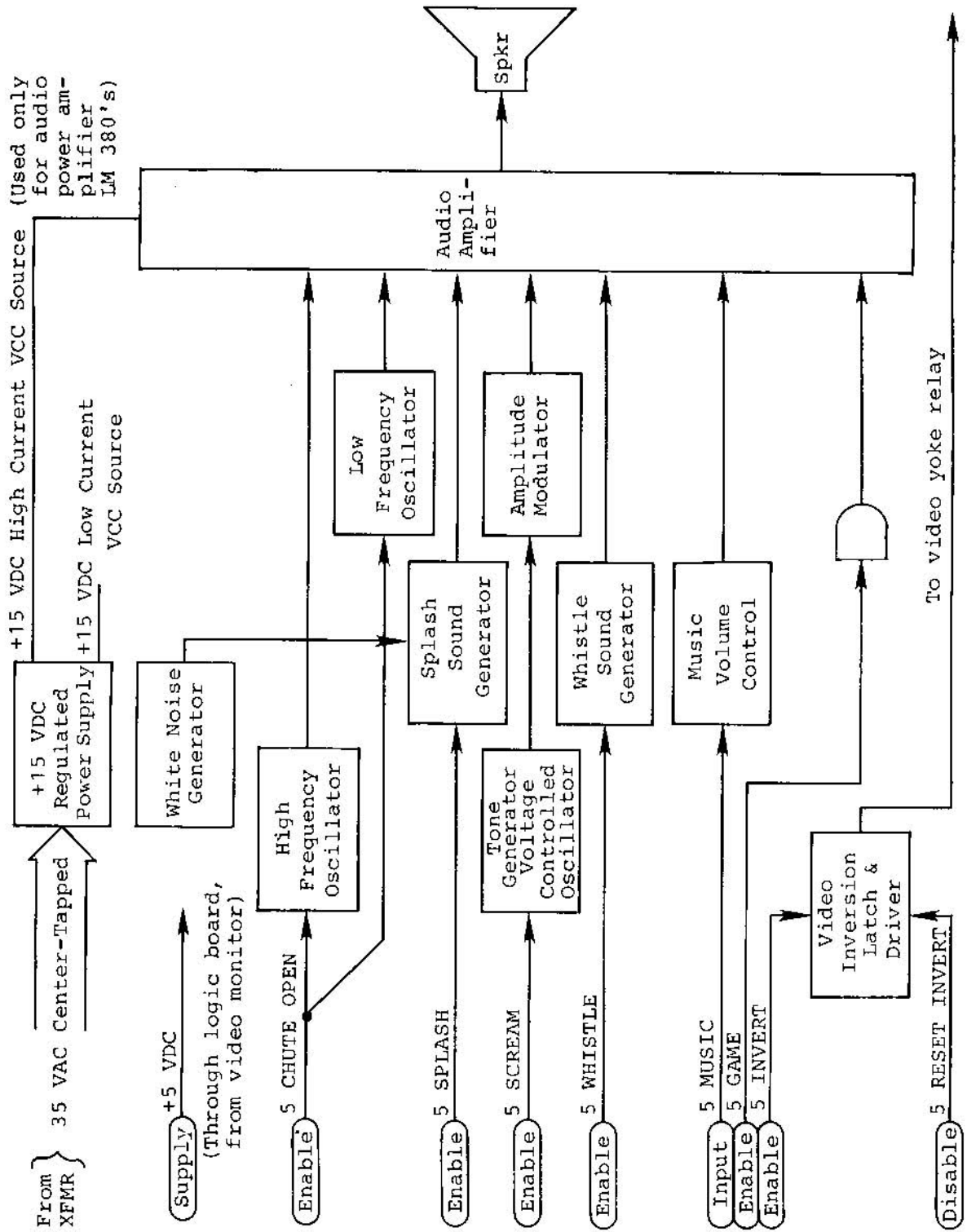

Figure 8: Audio Board Block Diagram

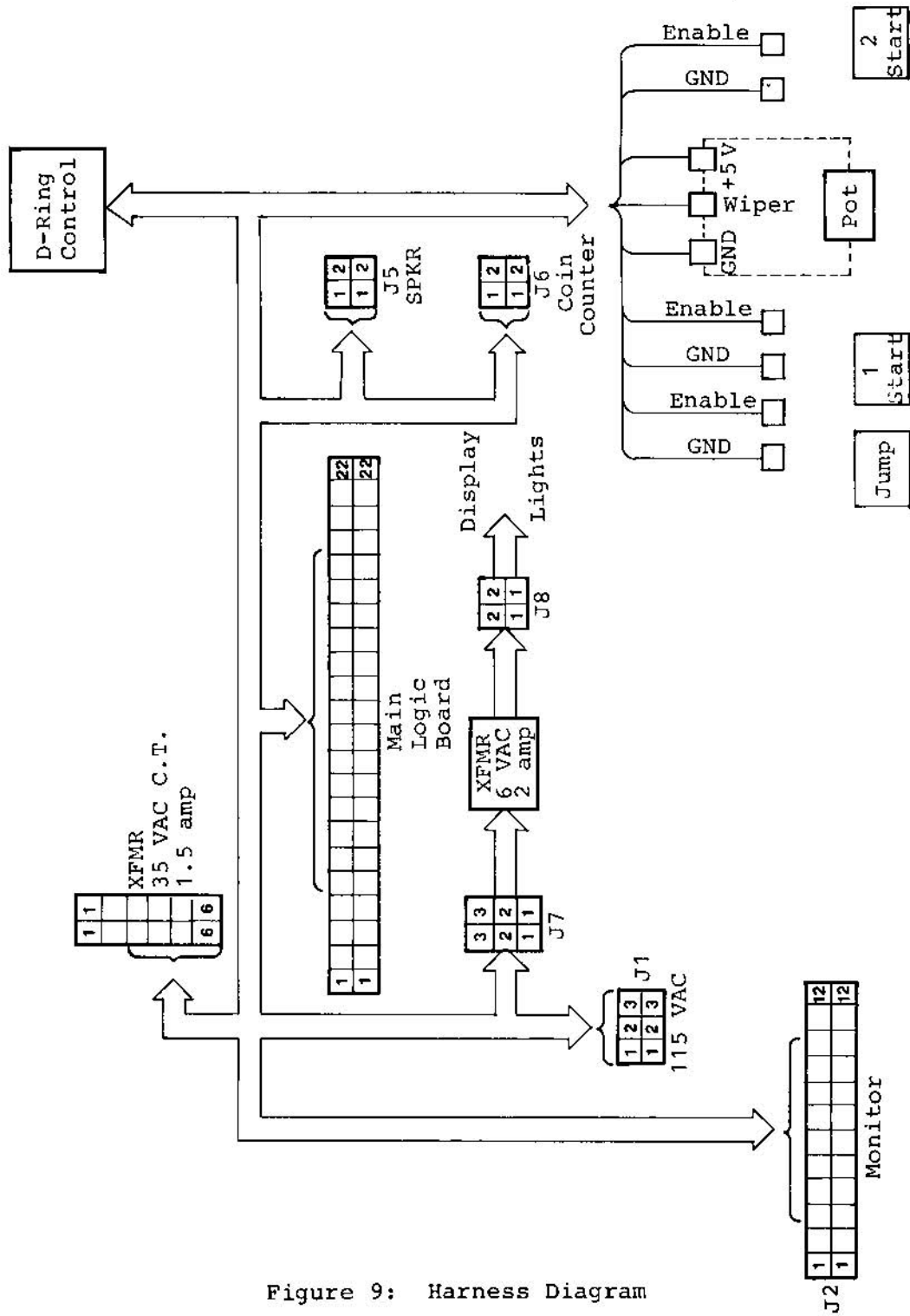
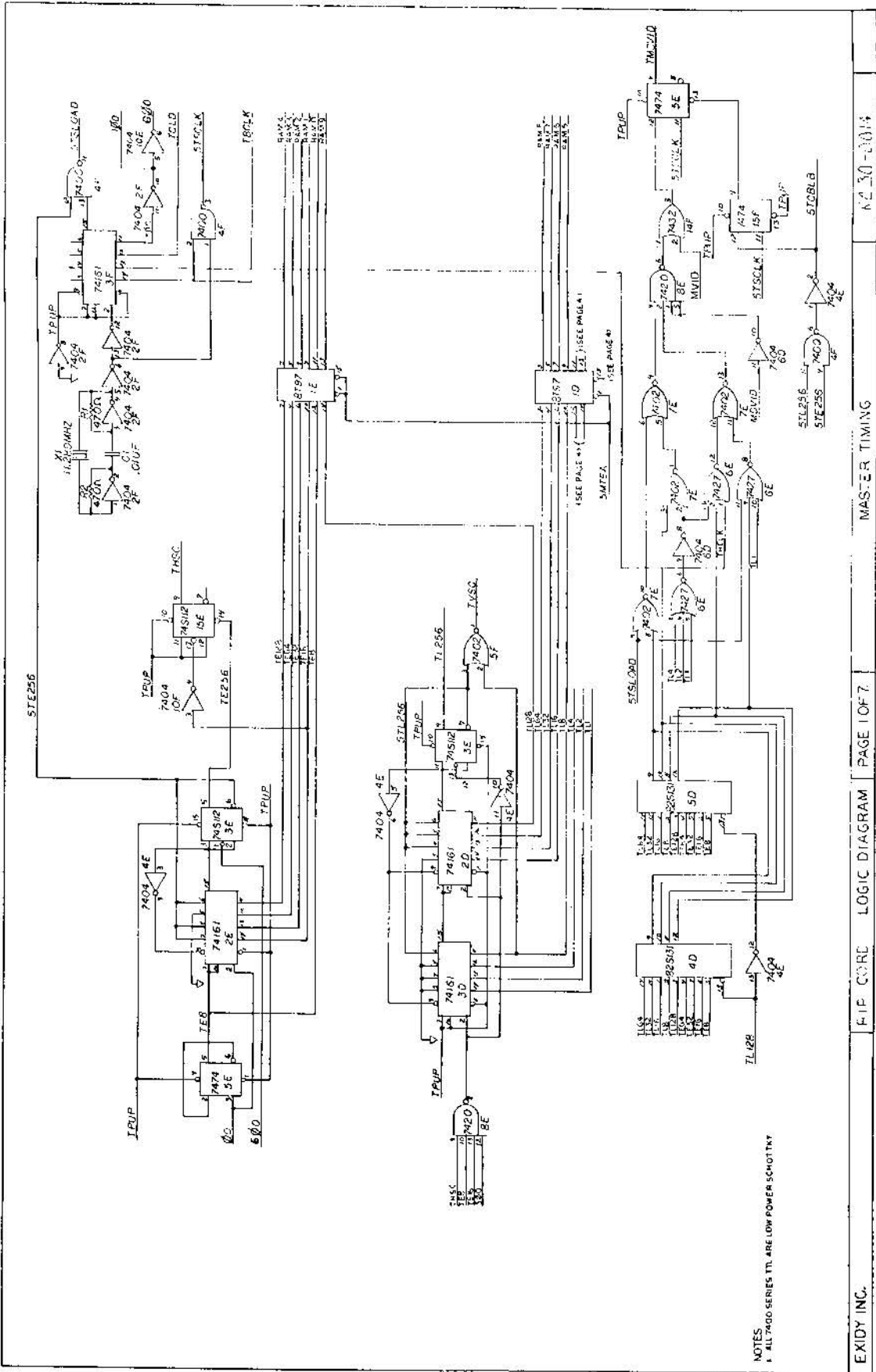

Figure 9: Harness Diagram

Table 1
Wiring Harness Pinouts

Pin	To	And	Signal	Pin	To	And	Signal
J1-1	J2-9	J3-1, J7-1	Switched power	J4-4	J2-1		Video
J1-2	J2-10	J3-2, J7-2	Power	J4-5			Player 1 start
J1-3	J2-7	J3-3	Power line ground	J4-6			Player 2 start
J2-1	J4-4		Video	J4-7			Jump
J2-2	J4-3		Video return	J4-8			Parachute open
J2-3	J4-2	J6-2	Power supply ground	J4-9			
J2-5			Monitor speaker	J4-10			
J2-6	J4-1	COINC	VCC	J4-11			
J2-7	J1-3		Power line ground	J4-12	J6-1	COINC	Coin drop switch
J2-8			Monitor speaker	J4-13			Static antenna*
J2-9	J1-1		Switched power	J4-14	J3-6		35 VAC C.T.
J2-9	J1-2		Power	J4-15	J3-5		35 VAC
J2-11				J4-16	J3-4		35 VAC
J2-12			10.8 VDC	J4-17			Relay -
J3-1	J1-1		Switched power	J4-18			Relay +
J3-2	J1-2		Power	J4-19			
J3-3	J1-3		Power supply ground	J4-20	J5-1		Speaker out
J3-4	J4-16		35 VAC	J4-21	J5-2		Speaker out
J3-5	J4-15		35 VAC	J4-22			Pot wiper
J3-6	J4-14		35 VAC C.T.	J5-1	J4-20		Speaker
J4-1	J2-6		VCC	J5-2	J4-21		Speaker
J4-2	J2-3		Ground	J6-1	J4-12	COINC	Coin drop switch
J4-3	J2-2		Video return	J6-2	J2-3	J7-8	Power supply ground
				COINC	J2-6		VCC
				COINC	J4-12		Coin drop switch

16 * The static antenna is a six foot long wire bundled in the harness.
One end is connected to J4-13; the other end is free.



NOTES
 1. ALL 7400 SERIES TTL ARE LOW POWER SCHOTTKY

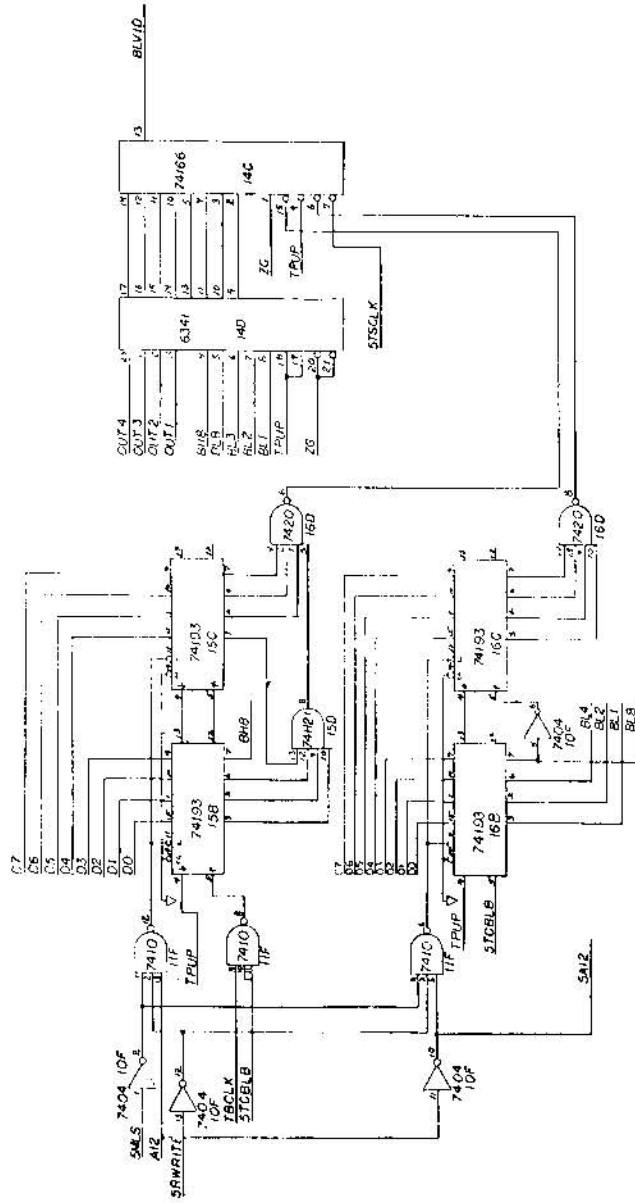

NOTES
 1. ALL 7400 SERIES ICs ARE LOW POWER SCHOTTKY

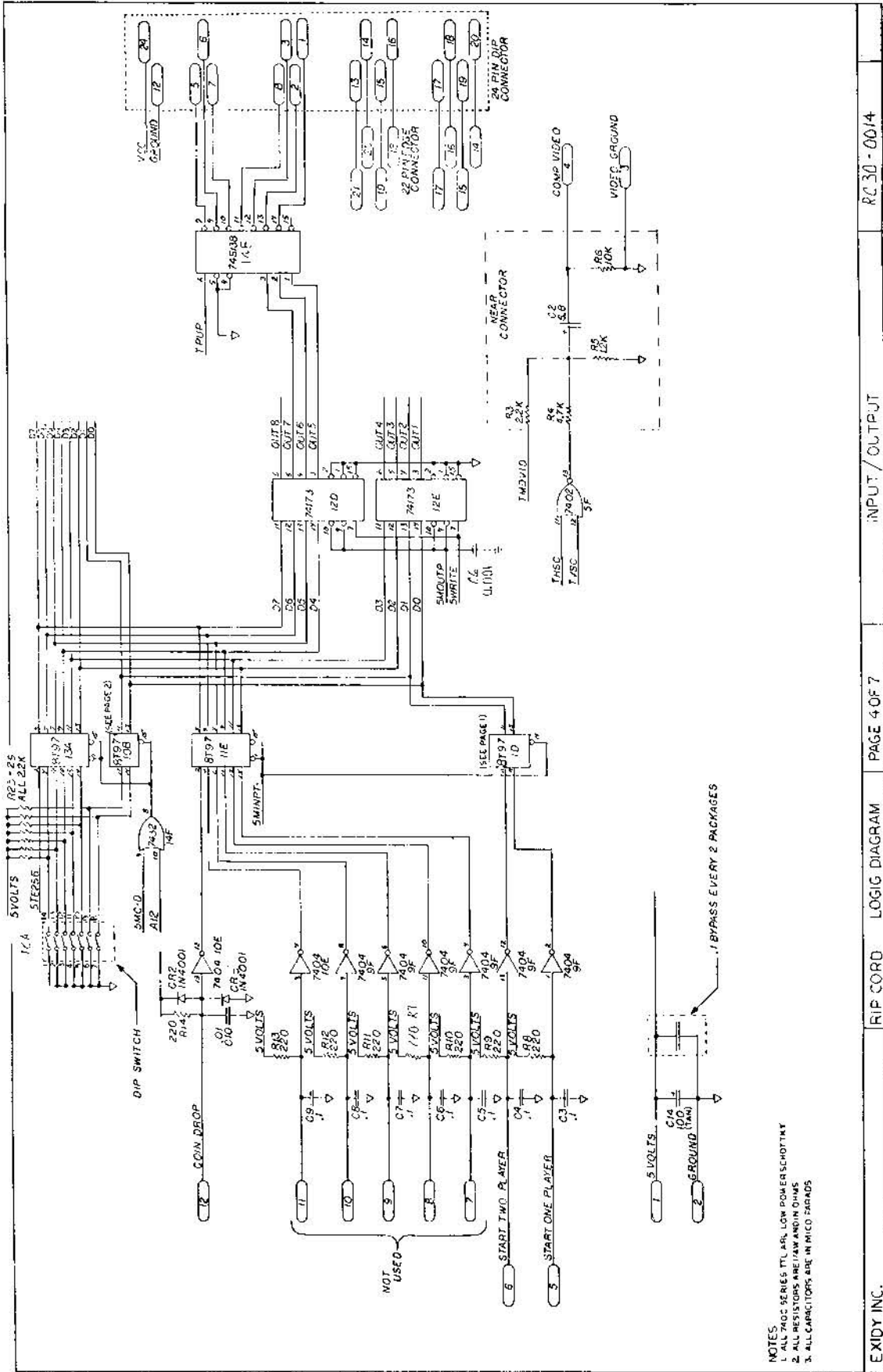

NOTES
 1. ALL 7400 SERIES TTL ARE LOW POWER SCHOTTKY
 2. ALL RESISTORS ARE 1/4W AND 5% OHMS
 3. ALL CAPACITORS ARE IN PICO FARADS

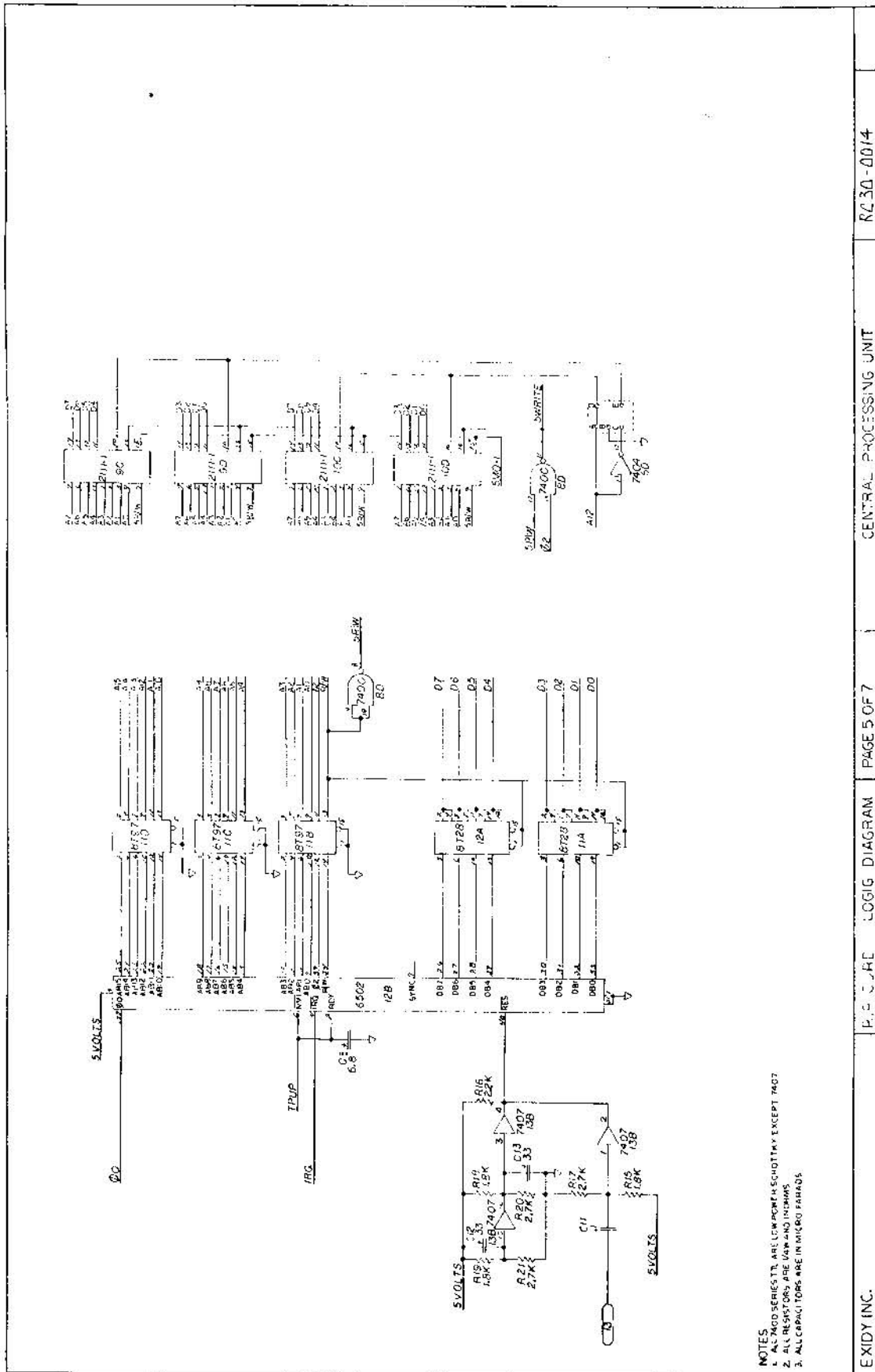

- NOTES
1. ALL 7400SERIES IC'S ARE LOW POWER SCHOTTKY EXCEPT 7407
 2. ALL RESISTORS ARE 1/4W AND 10% TOL
 3. ALL CAPACITORS ARE IN MICRO FARADS

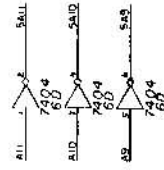
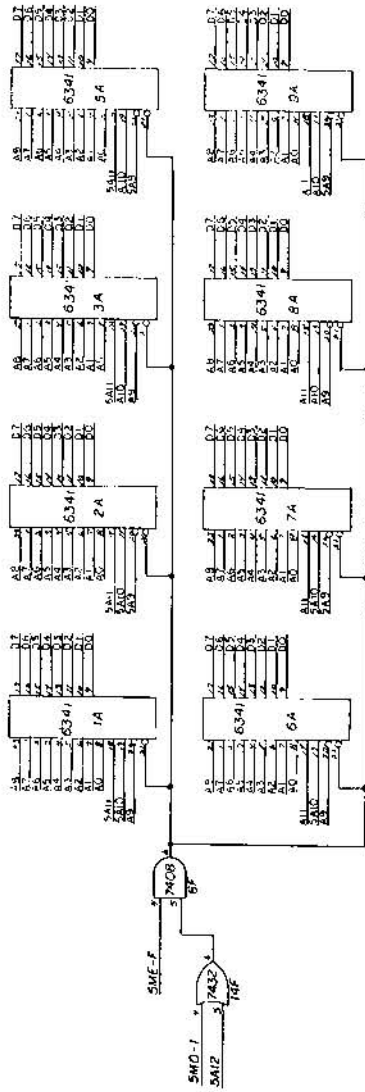

NOTES
 1. ALL 7400 SERIES TTL ARE LOW POWER SCHOTTKY

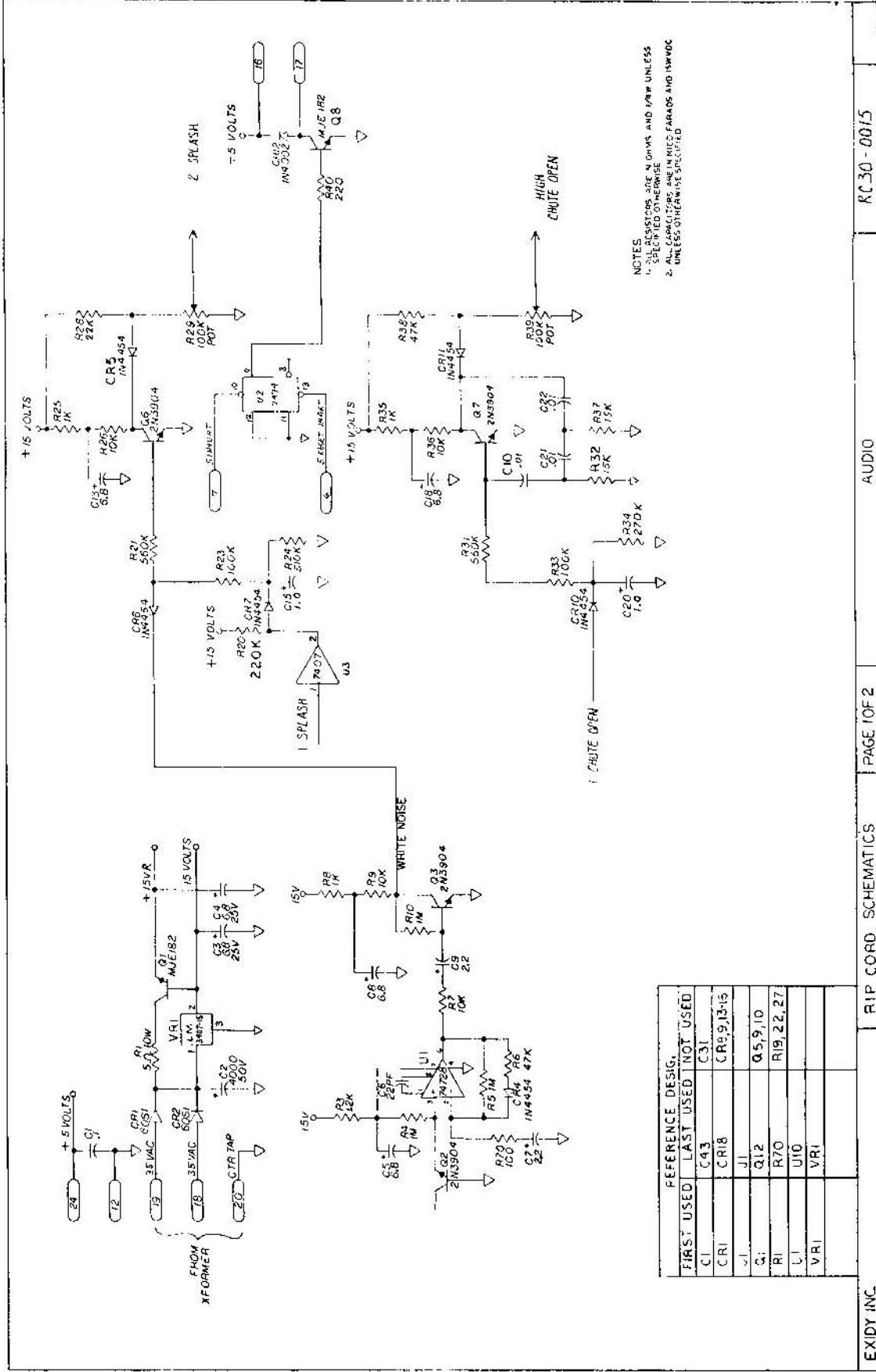

NOTES:
 1. RESISTORS ARE 1/4W AND 1% UNLESS SPECIFIED OTHERWISE
 2. ALL CAPACITORS ARE IN MICRO FARADS AND 15% UNLESS OTHERWISE SPECIFIED

REFERENCE DESIGN	
FIRST USED	LAST USED
C1	C43
CRI	CRI8
Q1	Q12
R1	R70
U1	U10
VR1	VR1

