

**service & operation
manual**

DE DATA EAST USA, INC.
470 Needles Drive
San Jose, CA 95112

780-0035-00

WARNING

This equipment generates and uses radio frequency energy and if not installed and used properly, i.e. in strict accordance with the instructions manual, may cause harmful interference to radio communications. It has been tested and found to comply with the limits for a Class A computing device pursuant to Subpart J of Part 15 of FCC Rules, which are designed to provide reasonable protection against such interference when operated in a commercial environment.

Operation of this equipment in a residential area is likely to cause interference in which case the user at his own expense will be required to take whatever measures may be required to correct the interference.

SPEED BUGGY OPERATION & SERVICE MANUAL

TABLE OF CONTENTS

1. IMPORTANT WARRANTY INFORMATION.....	2
2. GAME SET UP PROCEDURES	
A. Inspecting the game.....	3
B. Assembling your game.....	4
2. GENERAL INFORMATION	
A. Service panel operation.....	5
B. Option switches.....	6
C. Self-test procedures.....	8
D. Power switch & fuse information.....	9
E. Printed circuit board (PCB) service warning.....	9
3. REPLACEMENT PARTS BREAKDOWN.....	10
4. WIRING DIAGRAM.....	12

DATA EAST USA, INC.
470 NEEDLES DR.
SAN JOSE, CA. 95112

A. IMPORTANT WARRANTY INFORMATION

LIMITED WARRANTY

Data East USA, Inc. ("Seller"), warrants only to the initial purchaser of its products that the items listed below are free from defects in material and workmanship under normal use and service for the warranty periods specified:

1. Printed Circuit Boards (Game Logic) (90) days
2. Monitor PCBs and CRT (90) days

No other parts of Seller's products are warranted.

Warranty periods are effective from the initial date of shipment from Seller to its authorized distributors.

Seller's sole liability shall be, at its option, to repair or replace products which are returned to Seller during the warranty periods specified, provided:

1. Seller is notified promptly upon discovery by buyer that stated products are defective.
2. Such products are properly packaged and then returned, prepaid to Seller's plant.

This warranty does not apply to any parts damaged during shipping or handling, or due to improper installation or usage, or alteration. In no event shall the Seller be liable for any anticipated profits, loss of profits, loss of use, incidental or consequential damages or any other losses incurred by the customer in connection with the purchase of a Data East USA, Inc. product.

WARRANTY DISCLAIMER

EXCEPT AS SPECIFICALLY PROVIDED IN A WRITTEN CONTRACT BETWEEN SELLER AND PURCHASER, THERE ARE NO OTHER WARRANTIES, EXPRESSED OR IMPLIED, INCLUDING ANY IMPLIED WARRANTIES OF MERCHANTABILITY OR FITNESS FOR A PARTICULAR PURPOSE.

1. GAME SET UP PROCEDURES

Speed Buggy is shipped from the factory with the Steering Wheel removed from the Steering Shaft and must be installed during the set up procedures.

A. Inspecting the game

1. Carefully examine the exterior of the game cabinet for dents, scratches, chips, or broken parts.
2. Open the coin door with the proper key. Inside the coin door you will find the cashbox door and rear access door keys. Unlock and remove the rear access door. Inspect the following items:

- * Check that all plug-in connectors in the game harnessing are firmly plugged in. Replug any connectors found to be loose or unplugged.
- * Check the major subassemblies (power supply, coin door, and monitor) for secure mounting.
- * Remove the power cord from inside the main cabinet and slide the strain relief plate into the slot at the power cord access opening. Inspect the power cord for any cuts in the insulation or other damage.

NOTE: DO NOT PLUG IN YOUR SPEED BUGGY UNTIL YOU HAVE COMPLETED THE ASSEMBLY PROCEDURES.

- * Check the control panel assembly for any evidence of damage.
- * Check the hardware kit for the following materials:

o SCREW, M6 X 8 HEX CAP	3
o STEERING WHEEL	1
o DECAL, LOGO, STEERING HUB	1
o TUBE, SUPER GLUE	1

B. Assembling your game

1. Position the Steering Wheel on to the Steering Shaft and install the three (3) Hex Cap Screws supplied with your game.
2. Lightly sand the inner hub of the Steering Wheel to remove the glossy finish. This will enable the Logo Decal to adhere better to the Steering Wheel.
3. Apply two (2) drops of Super Glue to the center hub of the Steering Wheel (see figure 1) and spread it around the perimeter of the hub. Use care not to allow the glue to run on to the Hex Cap Screws retaining the Steering Wheel!
4. Carefully apply the Logo Decal to the center hub. Press down for a moment until the glue takes affect.

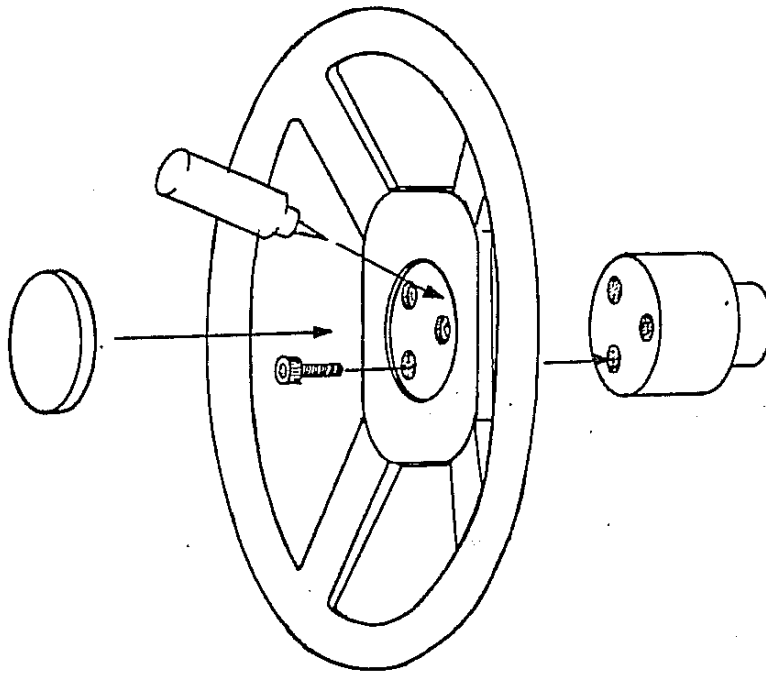

Figure 1

2. GENERAL INFORMATION

A. Service panel operation

The audio volume control, service switch, and self-test switch are all contained on the Service panel. This panel is located behind the coin mech door and mounted to the cashbox vault. See figure 2.

- * The volume control adjusts the overall loudness of the game.
- * The service switch allows for credits to be added to the game without incrementing the coin counter.
- * The Test switch activates the self-test mode to allow for testing and troubleshooting. See Self-test procedures for specific information.

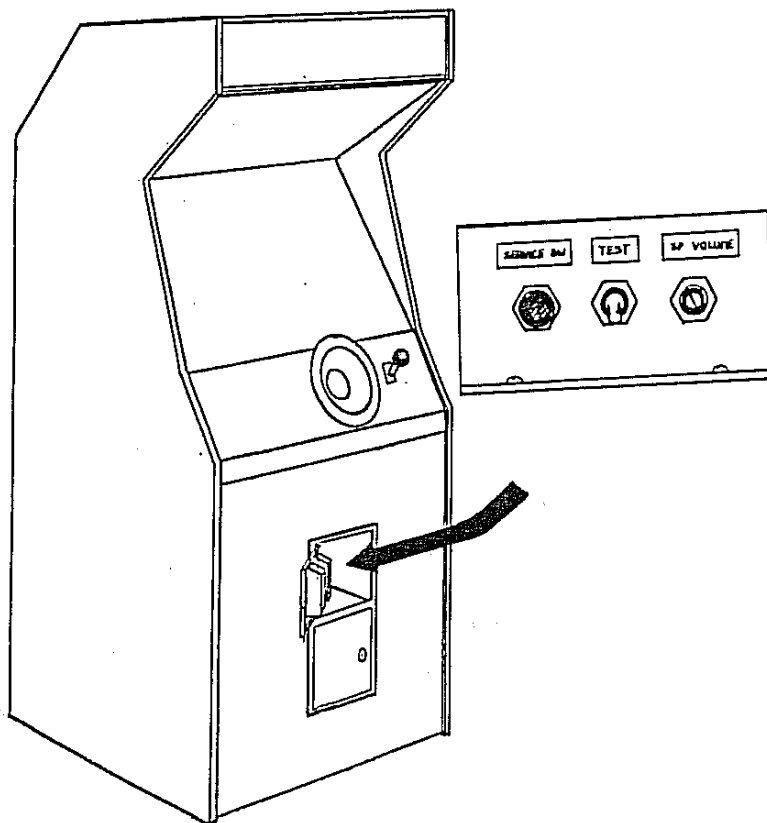

Figure 2

B. Option switches

Speed Buggy contains two dipswitch packages on the Main CPU PCB (see figure 3) which allow the operator to reconfigure the game options to suit the requirements of a particular location. These consist of different pricing, difficulty settings, and game time options. The tables on page 7 outline the available options.

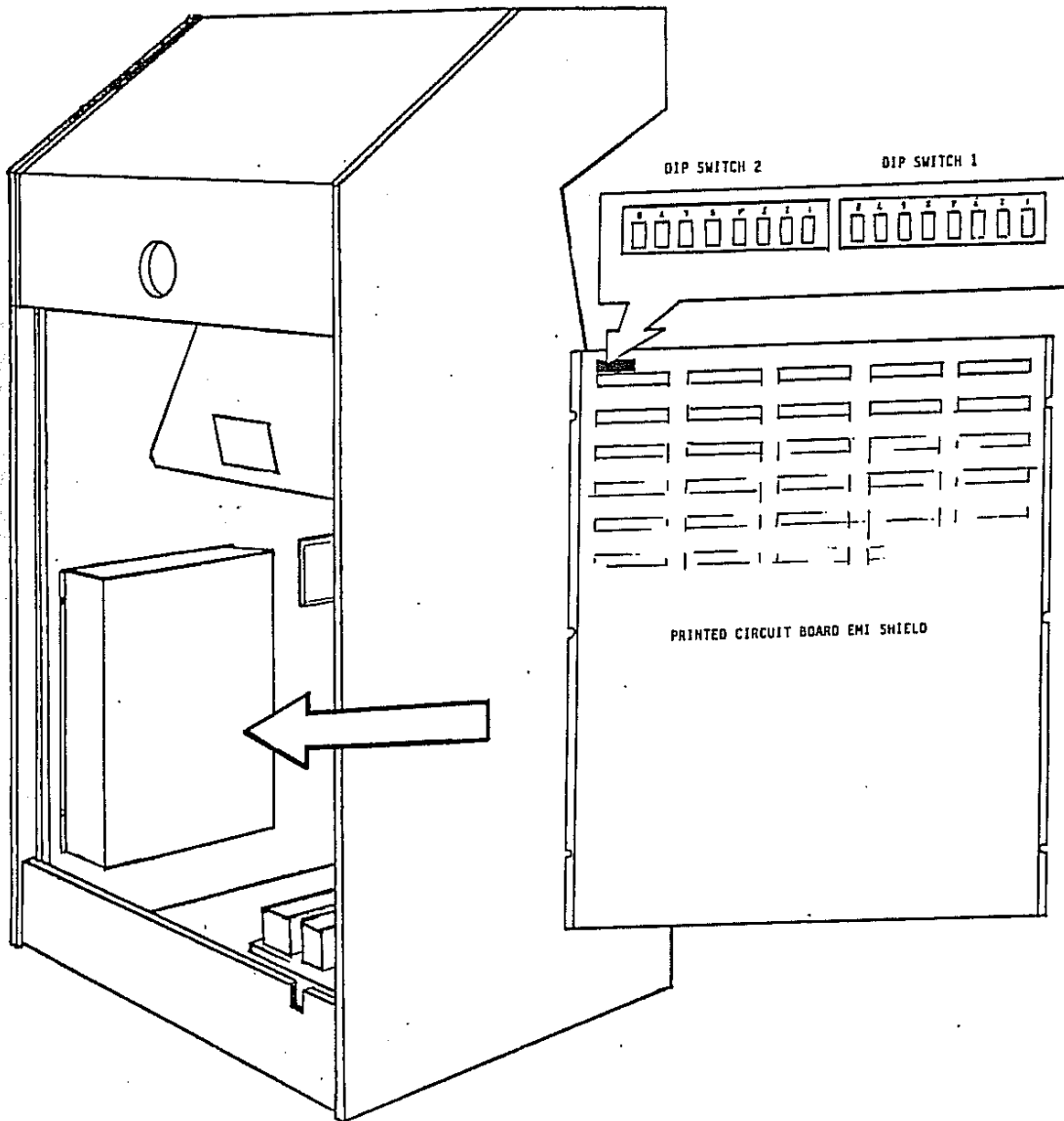

Figure 3

DIPSWITCH 1			1	2	3	4	5	6	7	8
COIN 1	1 COIN	1 CREDIT						ON	ON	ON
	2 COIN	1 CREDIT						OFF	ON	ON
	3 COIN	1 CREDIT						ON	OFF	ON
	1 COIN	2 CREDIT						OFF	OFF	ON
	1 COIN	5 CREDIT						ON	ON	OFF
	1 COIN	6 CREDIT						OFF	ON	OFF
	2 COIN	9 CREDIT						ON	OFF	OFF
	FREE PLAY							OFF	OFF	OFF
COIN 2	1 COIN	1 CREDIT				ON	ON			
	2 COIN	1 CREDIT				OFF	ON			
	1 COIN	2 CREDIT				ON	OFF			
	1 COIN	5 CREDIT				OFF	OFF			
DO NOT CHANGE			ON	ON	ON					

DIP SWITCH 2			1	2	3	4	5	6	7	8
DIFFICULTY LEVEL	EASY	A							ON	ON
		B							OFF	ON
		C							ON	OFF
	DIFFICULT	D							OFF	OFF
GAME TIME	SHORT	A					ON	ON		
		B					OFF	ON		
		C					ON	OFF		
	LONG	D					OFF	OFF		
DO NOT CHANGE						ON				
MESSAGE	ENGLISH				OFF					
	JAPANESE				ON					
DO NOT CHANGE			ON	ON						

C. Self-test procedures

The Speed Buggy game has a self-test mode that can be accessed by flipping on the test switch on the service panel. This test will automatically check out the game electronics and display an appropriate message as to the status. The self-test mode also allows you to check out all of the switches and player controls, activate the various sounds, reset the high score table, display current option settings, and display various test patterns for adjusting and testing the monitors.

Flip the test switch on the service panel up into the "on" position while the game is in the attract mode. The following information will be displayed on the monitor:

---SELF TEST---
HARDWARE GOOD

STEERING	0	SHIFT	LO
ACCEL	0	BRAKE	0
COIN 1	0	COIN 2	0
SERVICE	0	SOUND	0

--- GAME SPECIFICATION ---

COIN 1	2 COIN	2 CREDIT
COIN 2	2 COIN	2 CREDIT
SERV	1 SERV	1 CREDIT

GAME RANK B
TIME RANK B

STEERING: Turning the steering wheel clockwise will cause the indicator to increment from 0 to FF (hexidecimal). Turning the wheel counter-clockwise will cause the indicator to count backward.

ACCEL: Pressing the accelerator will cause the indicator to increment from 0 to F (hexidecimal). The 'F' indication will be displayed in yellow when the accelerator is fully depressed.

BRAKE: NOT USED

SHIFT: This indicates the current position of the shift lever, High or Low.

COIN 1: Activating the coin microswitch will increment the screen counter.
NOTE: Both the right and left coin switches are wired to the coin 1 input.

COIN 2: NOT USED

SERVICE: Activating the service pushbutton will increment the on-screen counter and also the Sound counter.

SOUND: Pressing the Service pushbutton will cause the Sound counter to increment and the game will emit a sound. Pressing the Service pushbutton subsequently allows you to step through and test each individual sound.

MONITOR TEST PATTERNS: The monitor test patterns can be accessed from the self-test mode by flipping the test switch off and then on again. Turning the steering wheel will select the various patterns. Flip the test switch to the off position to exit this test and return to the attract mode.

CLEAR HIGH SCORE TABLE: Speed Buggy stores the High Score tables in battery back-up memory. This allows the game to retain the current high scores when the power is removed. To clear the high score table, press the accelerator until it reads "F" on the indicator, and simultaneously press the service switch. The message: HIGH SCORE TABLE CLEARED will appear in the lower portion of the screen, indicating that the high score tables have been set to the original factory configuration.

D. Power switch & fuse information

This game features an on/off switch mounted on the Power Supply assembly. Be certain that the switch is in the OFF position before attempting to remove or repair any components in this game. There are also two fuses located next to the switch. They are labeled with their respective current ratings. These should only be replaced with FAST BLOW fuses of the same current rating.

* The 7 Amp fuse is on the 115 VAC line. In the event that it should blow, this will remove all power to the game. Check all wiring for proper connections and look for obvious damage to the Monitor, Power Supply, and Logic PCBs before replacing the fuse.

* The 1 Amp fuse is for the +12 VDC used for the coin door lamps. In the event that it should blow, the coin door lamps will not be illuminated. Check for damaged wires in the coin door before replacing the fuse.

E. Printed Circuit Board (PCB) Service Warning

WARNING! Due to the multi-layer PCB design incorporated into Speed Buggy, actual PCB repair should be done only by qualified service personnel. In the event of an actual PCB failure, the entire EMI cage with the PCBs secured inside should be returned to the factory for repair. Under no circumstances should repairs requiring desoldering of any components be undertaken by service personnel without the proper equipment and training in multi-layer board technology. These PCBs are very easily damaged by substandard rework and are not repairable once that damage is sustained.

NOTICE: IMPROPER REPAIRS WILL VOID WARRANTY!

This warning is for the Speed Buggy Main CPU PCB and the Graphics PCB and does not apply to monitor PCBs, power supply PCBs, and the small Optical Sensor PCBs.

REPLACEMENT PARTS BREAKDOWN

The following section lists the replacement parts available for the Speed Buggy game. Please refer to the Data East part numbers when ordering any parts from your distributor as this will aid in expediting your parts quickly and accurately.

FINAL ASSEMBLY

CABINET ASSEMBLY	365-0006-00
CONTROL PANEL ASSEMBLY	510-0058-00
COIN DOOR ASSEMBLY	510-0004-00
MONITOR ASSEMBLY, HORIZONTAL	510-0006-00
MONITOR BEZEL	380-0002-00
PEDAL UNIT, ACCELERATOR	510-0064-00
PCB ASSY, SOUND POWER AMP	510-0052-00
PCB SET W/EMI CAGE	510-0060-00
SWITCH PANEL ASSEMBLY, SVC, TEST, VOL.	515-0011-00
POWER SUPPLY ASSEMBLY	510-0059-00
SPEAKER, 6 X 9 OVAL	031-0001-00
SPEAKER GRILL	535-0028-00
MONITOR PLEX, CLEAR	660-0001-00
UNDERLAY CARD, BLACK	810-0011-00
LABEL, INSTRUCTION, SPEED BUGGY U/R	406-0021-00
DECAL, SIDE, SPEED BUGGY	820-0021-00
DECAL, SIDE, "5 TRACKS"	820-0027-00
DECAL, LOGO, "DATA EAST"	820-0016-00
PLEX, MARQUEE, SPEED BUGGY	830-0019-00
RETAINER, PLEX	535-0009-00

CONTROL PANEL ASSEMBLY

CONTROL PANEL, BLANK	535-0052-00
OVERLAY, CONTROL PANEL	800-0017-00
STEERING ASSEMBLY	515-0016-00
SHIFT LEVER ASSEMBLY	515-0014-00

STEERING ASSEMBLY

WHEEL, STEERING	530-0019-00
STEERING SUBASSEMBLY	515-0017-00
DECAL, LOGO, STEERING HUB	820-0026-00
PCB, OPTICAL SENSOR	520-0074-00
CHOPPER, OPTICAL, STEERING	535-0053-00
GEAR, STEERING	300-0002-00

SHIFT LEVER ASSEMBLY

KNOB, SHIFTER	350-0010-00
DECAL, LOW-HIGH	820-0025-00
MICROSWITCH, ROLLER ACTUATED	180-0016-00
SHIFT LEVER & ACTUATOR	515-0015-00

PEDAL UNIT, ACCELERATOR

ACCELERATOR SUB ASSY	515-0019-00
FOOT PEDAL SUB ASSY	515-0020-00
CHOPPER, OPTICAL	535-0031-00
PCB, OPICAL SENSOR	520-0060-00

POWER SUPPLY ASSEMBLY

SWITCHING REGULATOR, 12V @ 4.2A	510-0053-00
SWITCHING REGULATOR, 5V @ 20A	510-0054-00
TRANSFORMER, ISOLATION	010-0001-00
SWITCH/FUSE BRACKET ASSEMBLY	515-0007-00
NOISE FILTER, AC LINE	150-0001-00

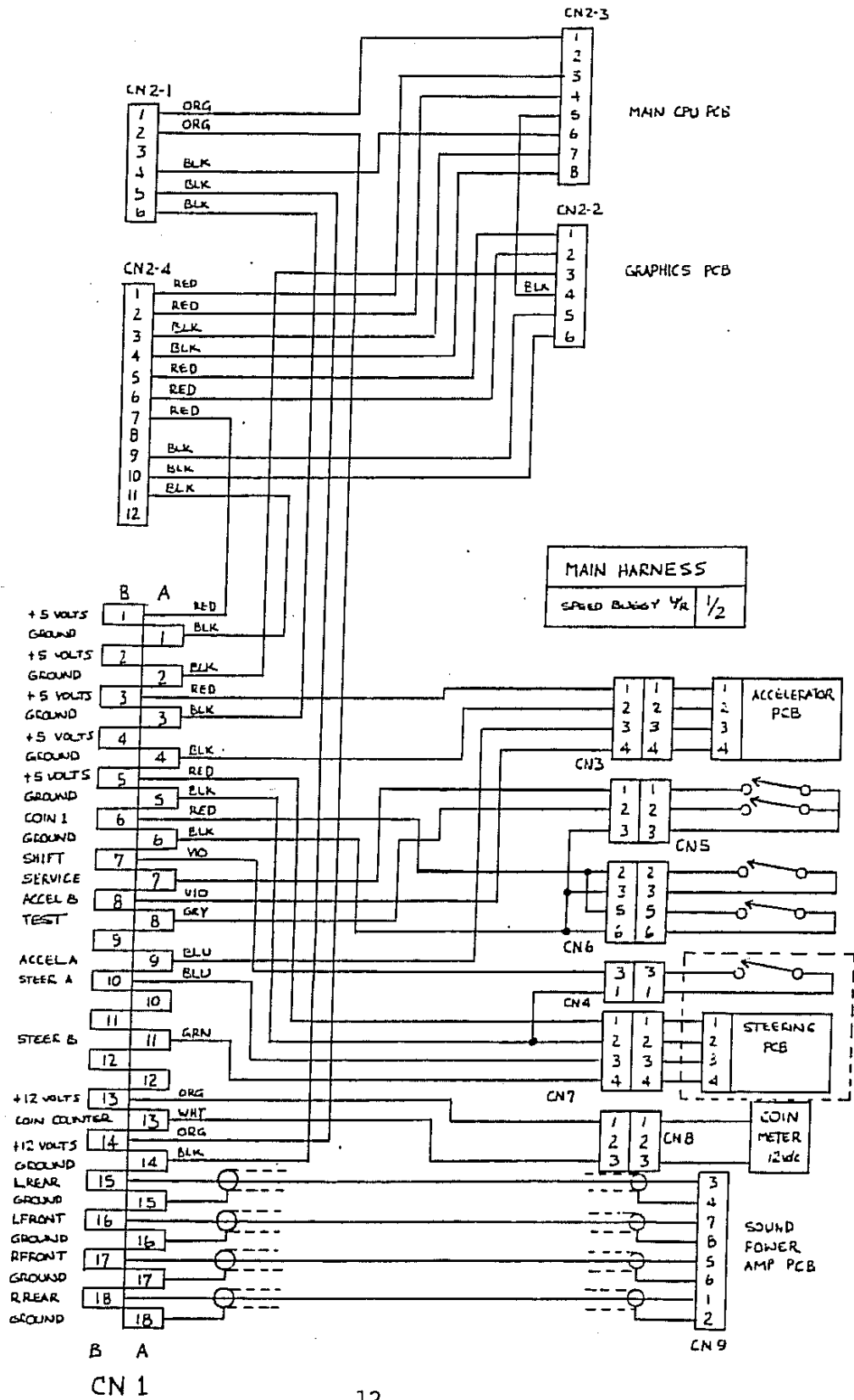

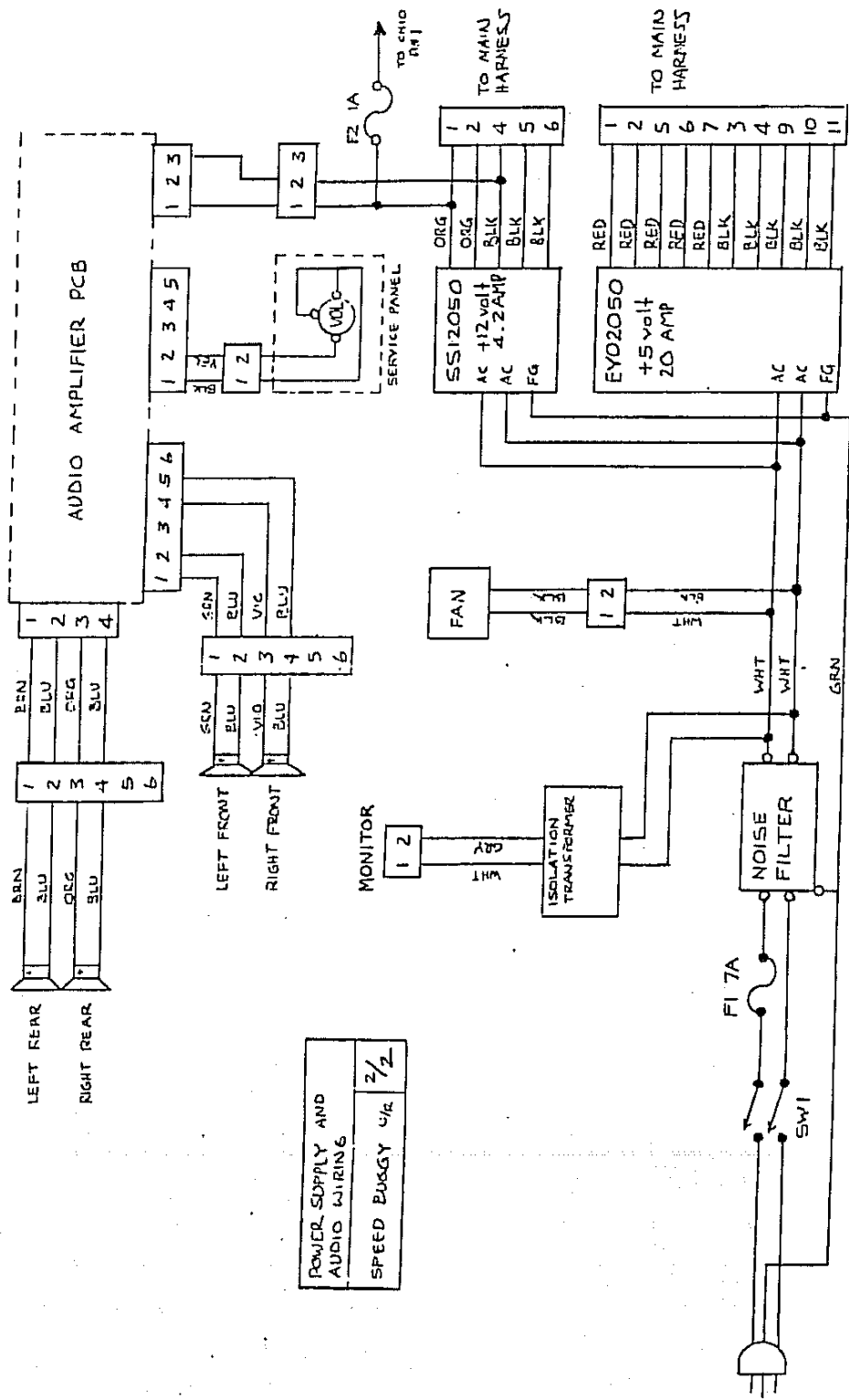

POWER SUPPLY AND
AUDIO WIRING
SPEED BUGGY 4/R 2/2

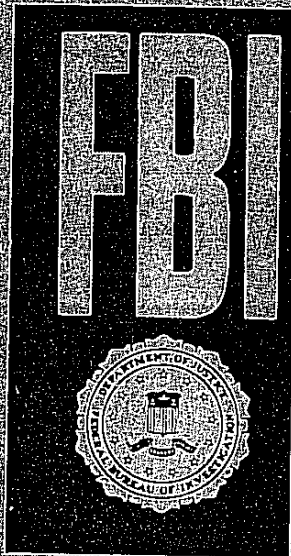

WARNING

Federal law provides severe civil and criminal penalties for the unauthorized reproduction, distribution, or exhibition of copyrighted audiovisual works and video games.

The Federal Bureau of Investigation investigates allegations of criminal copyright infringement.

