Owners Manual for Thief

Pacific Novelty Manufacturing
~~Customer Service Department~~
4094 Glencoe Avenue
Marina Del Rey, Ca. 90291
~~(213) 822-0399~~

(FL010382)

T h i e f C O P Y R I G H T (C) 1 9 8 1 P N M I N C . A L L R I G H T S R E S E R V E D

I N D E X

PART I	-	QUICK REFERENCE CHART OF SETTINGS
PART II	-	OPERATIONS MANUAL
PART III	-	DIAGNOSTICS
PART IV	-	NOTICES

QUICK REFERENCE CHART OF SETTINGS - SECTION I

TOP LEFT DIP SWITCH

1 2

0 0	10,000 POINTS / BONUS CAR	SOFTWARE VERSION:
1 0	20,000 POINTS / BONUS CAR	011082
0 1	30,000 POINTS / BONUS CAR	
1 1	40,000 POINTS / BONUS CAR	

SWITCH 3 - ON = AWARD ONLY SINGLE BONUS CAR AT SCORE SET BY SWITCHES 1 AND 2 DURING ENTIRE GAME.

OFF = AWARD A CAR AT INTERVALS LEVELS SET BY SWITCHES 1 AND 2 (MULTIPLE CARS).

SWITCH 4 - ON = BONUS CARS FOR SCORES ABOVE
OFF = NO BONUS CARS FOR ANY SCORE

- 5 6 7 8 ← SWITCH NUMBERS
- 0 0 0 1 - BURN-IN TEST (1ST 2 DIGITS IN CHECKSUM=SOCKET#)
 - ~~1 0 0 1 - COLOR BAR DISPLAY~~
 - 0 1 0 1 - CROSS HATCH GRID
 - 1 1 0 1 - CONTINUOUS COLOR MAP WRITES
 - ~~0 0 1 1 - VIDEO RAM ADDRESS SELECT WRITES~~
 - 1 0 1 1 - VIDEO BIT MOVE
 - 0 1 1 1 - IO BOARD DRIVER TEST
 - ~~1 1 1 0 - Display current options in effect~~
- *** Close SLAM switch or turn off/on same for new test ***
*** DON'T FORGET TO TURN OFF 5,6,7 & 8 WHEN DONE!!!!!! ***

Top right dip switch

1 2

0 0	25 CENTS/GAME
1 0	50 CENTS/GAME
0 1	2 games/25 cents
1 1	1 game/25 3 games/50

3 4

0 0	3 CARS/GAME
1 0	4 CARS/GAME
0 1	5 CARS/GAME
1 1	7 CARS/GAME

5 6 7 8

X X ^ X
if on then cocktail version
~~if off then upright version~~

SYMBOLS: X ← IGNORE ; 1 ← TURN ON (CLOSE) ; 0 ← TURN OFF (OPEN)

QUICK REFERENCE CHART OF SETTINGS - SECTION I

 TOP LEFT DIP SWITCH

1 2

0 0	10,000 POINTS / BONUS CAR	SOFTWARE VERSION:
1 0	20,000 POINTS / BONUS CAR	011032
0 1	30,000 POINTS / BONUS CAR	
1 1	40,000 POINTS / BONUS CAR	

SWITCH 3 - ON = AWARD ONLY SINGLE BONUS CAR AT SCORE SET BY SWITCHES 1 AND 2 DURING ENTIRE GAME.
 OFF = AWARD A CAR AT INTERVALS LEVELS SET BY SWITCHES 1 AND 2 (MULTIPLE CARS).

SWITCH 4 - ON = BONUS CARS FOR SCORES ABOVE
 OFF = NO BONUS CARS FOR ANY SCORE

5 6 7 8 <- SWITCH NUMBERS
 0 0 0 1 - BURN-IN TEST (1ST 2 DIGITS IN CHECKSUM=SOCKET#)
~~1 0 0 1 - COLOR BAR DISPLAY~~
 0 1 0 1 - CROSS HATCH GRID
 1 1 0 1 - CONTINUOUS COLOR MAP WRITES
~~0 0 1 1 - VIDEO RAM ADDRESS SELECT WRITES~~
 1 0 1 1 - VIDEO BIT MOVE
 0 1 1 1 - IO BOARD DRIVER TEST
~~1 1 1 0 - Display current options in effect~~
 *** Close SLAM switch or turn off/on game for new test ***
 *** DON'T FORGET TO TURN OFF 5,6,7 & 8 WHEN DONE!!!!!! ***

 Top right dip switch

~~1 2~~

0 0	25 CENTS/GAME
1 0	50 CENTS/GAME
0 1	2 games/25 cents
1 1	1 game/25 3 games/50

3 4

0 0	3 CARS/GAME
1 0	4 CARS/GAME
0 1	5 CARS/GAME
1 1	7 CARS/GAME

5 6 7 8

X X ^ X

if on then cocktail version
 if off then upright version

 SYMBOLS: X <-IGNORE ; 1 <-TURN ON (CLOSE) ; 0 <- TURN OFF (OPEN)

OPERATIONS MANUAL SECTION II

Your THIEF game incorporates a number of adjustments in order to control the time the Player can tie up the machine. You can control the following:

- ~~1. Number of cars per game 3, 4, 5 or 7 cars.
We suggest 3 cars per game~~
- ~~2. Bonus car feature at a selected score level
We suggest you turn this feature on~~
- ~~3. Single shot bonus or multiple bonus cars
We suggest Multiple bonus cars~~
- ~~4. Points needed for bonus car.
We suggest 10,000 dollars per bonus car
You can set it at 20,000 , 30,000 or 40,000 dollars.~~
- ~~5. Price per play.
We suggest you follow your location policy as to price.
you can select 25 or 50 cent play.~~

OPERATIONS MANUAL SECTION II

Controls used in the Game

The Player has the following controls:

Joystick - When moved in any of four directions, the Player's car will move in that direction. That is up, down, left, right. ~~The joystick contains four switches which are depressed by the movement of the control by the player.~~

One Player Start - Starts the single player game if an appropriate number of coins have been deposited.

Two Player Start - Starts the two player game if an appropriate number of coins have been deposited.

OPERATIONS MANUAL SECTION II

~~Helpful Hints about your Game~~

There are a number of areas you should pay attention to in order to maximize your earnings from this game.

~~Care of the Color Monitor-~~

The primary display device for this game is the Color Monitor. When you receive your game, or move it around, you may find that the game has acquired what appears to be a case of multi-colored blotchy color areas. These are caused by stray magnetic fields which magnetize the tube and surrounding metal. We suggest that you 'desauss' your game with a desaussing coil. The coil is a large round electromagnet which plugs into the 110 volt line. Since the power line is AC it has the property of demagnetizing the parts near and on the monitor. Your distributor most likely has such a coil and will be able to instruct you in its use (if you need it at all). All controls on the monitor have been preset at the factory. If you change any of the controls you better know what you are doing!

~~Care of Tape Unit-~~

This game incorporates an leaderless autoreverse cassette which produces the chatter between cars as well as the crashing sounds when the cars are hit. We suggest that you pay particular attention to the maintenance of this unit. With your game instruction manual you will find an instruction manual for the car stereo in your unit. Refer to this for any information as to the maintenance and care of this unit. If you find that the Stereo unit is functional (try playing a regular tape in it), yet the leaderless cassette doesn't play, you may have a damaged or worn out tape (under normal use (?) these tapes have a lifetime of over two(2) years). You may purchase from PNM, a replacement for your original tape.

OPERATIONS MANUAL SECTION II

Care of Player Controls-

~~The pushbutton parts used in the front panel of the game can be directly cross-referenced to WICO replacements. The leaf switches are gold plated and may be cleaned with an ordinary piece of paper rubbed between the two surfaces. An ordinary point adjusted may be used to set the spacings. The joystick should be aligned so that it is sensitive for deflection in 4 directions.~~

Coin Door -

~~The list of things that can be done to a coin door is unbelievable. If the mech fails to accept coins after months of service we suggest you clean it (Who's buried in Grant's Tomb?). The door incorporated a slam switch which is NORMALLY OPEN. To test the operation, kick the door and watch for a game reset. The slam switch erases ALL credits (sorry Charlie!).~~

~~Cabinet Levelers -~~

~~The cabinet is shipped with levelers used to make the game level (logical?). We strongly suggest that you install them to: A. Protect your floors from scratching; and B. To keep your players from waltzing your game across the floor.~~

TLC -

~~Treat you game with a lot of care and it will make bass and bass of quarters for you. Here at the factory we put a lot of care into the programming and building of the game to make the game a success. Keep the game working in top form and both you and the players will be happy cookies.~~

DIAGNOSTICS SECTION III

DIAGNOSTICS SECTION III

```
*****
*****
*****
***** * DIAGNOSTIC TEST * *****
*****
***** PACIFIC NOVELTY MANUFACTURING *****
*****
*****
*****
```

~~The Rom test set supplied allows the technician to test the electronics package in the Thief game.~~

- ~~1. DIAGNOSTICS ARE ENABLED WHEN SWITCH 8 IS ON - (THE BOTTOM MOST AND LEFT SWITCH).~~
- ~~2. CLOSE SLAM SWITCH TO SIGNAL CHANGE OF DIAGNOSTICS SWITCH~~

```
1 2 3 4 5 6 7 8 <- SWITCH NUMBERS
X X X X 0 0 0 1 - BURN-IN TEST(1ST 2 DIGITS IN CHECKSUM=SOCKET#)
X X X X 1 0 0 1 - COLOR BAR DISPLAY
X X X X 0 1 0 1 - CROSS HATCH GRID
X X X X 1 1 0 1 - CONTINUOUS COLOR MAP WRITES
X X X X 0 0 1 1 - VIDEO RAM ADDRESS SELECT WRITES
X X X X 1 0 1 1 - VIDEO BIT MOVE
X X X X 0 1 1 1 - IO BOARD DRIVER TEST
X X X X 1 1 1 1 - (RESERVED FOR FUTURE USE) (SETTINGS)
```

DIAGNOSTICS SECTION III

~~BURN-IN Test Rom instructions~~

~~The Burn in test supplied to you contains the following tests:~~

- ~~1: Checksum of all roms in the system
Reports the condition of all ROMS on board.~~
- ~~2: Harness/Control/IO board Test sequence
Displays the position of all switches in the system.~~
- ~~3: Dip Switch Display
Shows the switch positions of the two dip switches on the IO board.~~
- ~~4: 2114 RAM test - Test the condition of the on board RAM.~~
- ~~5: 4116 RAM test - Test the display RAM.~~
- ~~6: Coprocessor test - Test various section of coprocessor~~

DIAGNOSTICS SECTION III

* TYPICAL DISPLAY *

<Checksums>	<Controls>
00 <ok>	<Player 1>
02 <ok>	.
04 <ok> <- This is the Player 1
06 <ok>	. Control panel
08 <ok>	.
10 <ok>	<Player 2>
12 <ok>	.
14 <ok> <- This is the Player 2
	. Control panel
	. (Cocktail version)

 <- These are the Dip Switches
 <- . . . Open circuit -- Closed circuit

 2114 ERR <- Bad 2114
B4=<ok> 4116 ERR <- Bad 4116
F4=<ok>

Note that from time to time you may get a 4116 error message. Since the 4116 ic's are used in the video section, you can still have a very playable game with a small fraction of errors.

If you get any error messages in the lower left side of the screen, these are caused by problems with the Coprocessor board. Errors such as 'CNTXT ERR' or 'ADDR XLAT ERR' are Coprocessor generated. If you receive a large number of messages in the lower left hand side, you either have the power missing from the coprocessor or else the 50 pin flat cable has come loose.

All errors besides 4116 are of a very serious nature and should be corrected immediately as they impair the earnings of the game.

DIAGNOSTICS SECTION III

!!!!!!!!!!!!!!!!!!!!
!!!! CAUTIONS !!!!
!!!!!!!!!!!!!!!!!!!!

~~There are a number of dependences and limitations of this particular test rom.~~

~~1. The whole realm of tests depend on the existence of GOOD RAM in the lowest 1k segment of memory.~~

~~2. The tests used for the detection of errors and the 2114 and 4116 tests are very limited in their scope and the ability to trace down subtle problems in these areas.~~

CHECKSUMS

~~The first test (checksums) adds up the contents (numbers in ROM) and generates a checksum number. The Test Rom has a table of correct values and upon finding the correct value displays <ok> to indicate it found what it expected. In case it doesn't find the correct number it will display a four digit number (16 bit hexadecimal checksum found). In case you do get something other than the <ok> check you manual for any changes which may have been made to that rom since the production of the test rom.~~

DIP SWITCHES

~~The Dip switch display provides you with a method of determining the position of the dip switches located on the IO (small) board. What you are seeing on the screen is the internal representation (as the computer sees them) of the dip switches on the IO board. This test is useful in determining the most low level operation of the IO board.~~

DIAGNOSTICS SECTION III

PLAYER CONTROL DISPLAY

One thing that is most annoying is problems in the harness and the adjustment of switches. This test shows you the opening and closing of switches on the:

- A: Player 1 control panel
 - B: Player 2 control panel
 - C: Coin and slam switches
-

The dots (.) shown represent the identical switches and their correct positions on the front panel of the actual game. The only exception to this rule is on the Player 2 panel. In this case you will find that the positions used for the one and two Player start have been replaced with the COIN and SLAM switches. The symbols (.) and (*) represent the OPEN and CLOSED positions of the switches on the front panel.

Theory of Operation

Imbedded in the base of the ROM0 rom is code which detects the existence of a Rom14. If it does find a rom in this position it checks for the proper contents at the beginning of the ROM14 and if they are correct, the system begins execution at beginning of ROM14 + 6.

DIAGNOSTICS SECTION III

COLBAR - Color Bar display generator

THIS routine generates a color bar pattern to test the operation of the video section. The test itself erases a byte to zero then writes to the selected plane of display memory.

You will find this routine especially useful for testing the Wait line back to the CPU as well as the timing of writes.

The following must be running for this test to operate:

- 1 CPU and select logic to RAM/ROM
- 2 CPU RAM

DIAGNOSTICS SECTION III

VIDSEL - Video Ram select writes

~~In this test we cause each of the Video RAM select lines to be selected. Each Video RAM is read and written to in sequence. This test is designed to check that the Video section is actually connected to the CPU section.~~

~~Use this test to check for the existence of /MRD + /MWR + /WAIT as well as the address lines leading to the Video RAMS and the signals internal to the video circuit. Each address line going to the Video RAMS is exercised as well. In addition the data written is incremented after each pass through the test.~~

~~The test will try to reset the Video Controller chip and then begin to read and write data to each of the address boundary location points 1,2,4...last significant address. These are the only locations which will be written to.~~

~~Sync your scope to the /OUT 0 select as this signals the start a select sequence.~~

DIAGNOSTICS SECTION III

VIDBIT - Video bit Move

~~This routine generates a single bit write in each and every cell (byte) in the display memory. It is intended to detect stuck bits in individual planes.~~

~~In the normal operation of this routine, you will see thirty two lines across the screen. On each pass you will see the entire group move to the side one single cell. You will notice that the test repeats after every eight writes due to there being only eight bits to test per cell.~~

~~Since the memory is arranged to the processor as eight bit bytes and the internal representation is as 4 bit pixels. You may be able to isolate the problem to whether the problem is of a 4 or 8 bit error pattern. Internal to video or in the interface between the two.~~

~~This test requires that the CPU be functioning as well as the 2114 Ram section. Selects to these sections must of course be operating.~~

DIAGNOSTICS SECTION III

PSGTST - IO board driver test

Programmable sound generator and OUTPUT DRIVE
test

~~In the Pss test, each channel of the pss is, in
sequence frequency modulated at full volume.~~

~~After all the Pss's have been tested, the
relays and transistor drivers are sequenced in
order.~~

Sequence:

- ~~1 All units off~~
- ~~2 Tape power on
Talk track on
Coin meter power on~~
- ~~3 Explosion track relay on~~
- ~~4 Explosion track relay off
Coin meter off
Talking track relay off~~
- ~~5 Start at sequence number 1 again~~

~~While each of the above is going on, each of the 6 channels of
the PSG's (3 channels per PSG) is being frequency modulated.
This makes a sort of Whooop, Whooop, Whooop and pause sound. The
frequency modulated sequence is carried out on the total of 6
channels supplied by the two PSG's.~~

NOTICES IV

WARRANTY

Pacific Novelty Manufacturing (PNM) warrants that its circuit boards and parts are free from any ~~defects in workmanship and materials under normal use and service, for a period of thirty (30) days from date of shipment. PNM also warrants its television monitors (in games which use them) to be free from any defects in workmanship and materials under normal use and service, for a period of Thirty (30) days from date of shipment. No other of the Seller's products or parts therefor are warranted.~~

If the product described in this manual should fail to conform to this warranty, The seller's sole ~~liability shall be, at its option, to repair, replace, or credit Buyer's account for such products which are returned to the Seller during the said warranty period provided that:~~

~~A) The Seller is promptly notified IN WRITING upon discovery by the Buyer, that said products are defective.~~

~~B) Such products are returned to the Seller's plant; and~~

~~C) Seller's examination of the said products discloses to the Seller's satisfaction that such alleged defects existed and were not caused by alteration, improper repair, installation, accident, misuse, improper testing or accident.~~

~~In NO event shall Seller be liable for incidental or consequential damages such as loss of profits, loss of use or any other such losses.~~

~~Except for any express warranty set forth in written contract between Seller and Buyer which contract supersedes the terms of this order, this warranty is expressed in lieu of all other warranties expressed or implied, including the implied warranties of merchantability and fitness for particular purpose, and of all other obligations or liabilities on the Seller's part, and it neither assumes, nor authorizes any other person to assume for the Seller any other liabilities in connection with the sale of products under this order.~~

NOTICES IV

~~WARNING!~~

~~This equipment generates, uses and can radiate radio frequency energy. If not installed and used in accordance with the instruction manual - it's use may result in interference with radio communication services. As temporarily permitted by regulations, it (the same) has not been tested for compliance (with the limits for class A computing devices) pursuant to sub part J of part 15 of F.C.C. rules, which are designed to provide reasonable protection against such interference. Operation of this equipment in a residential area is may cause interference - in which case, the user, at his own expense, will be required to take whatever measures may be required to correct the interference.~~

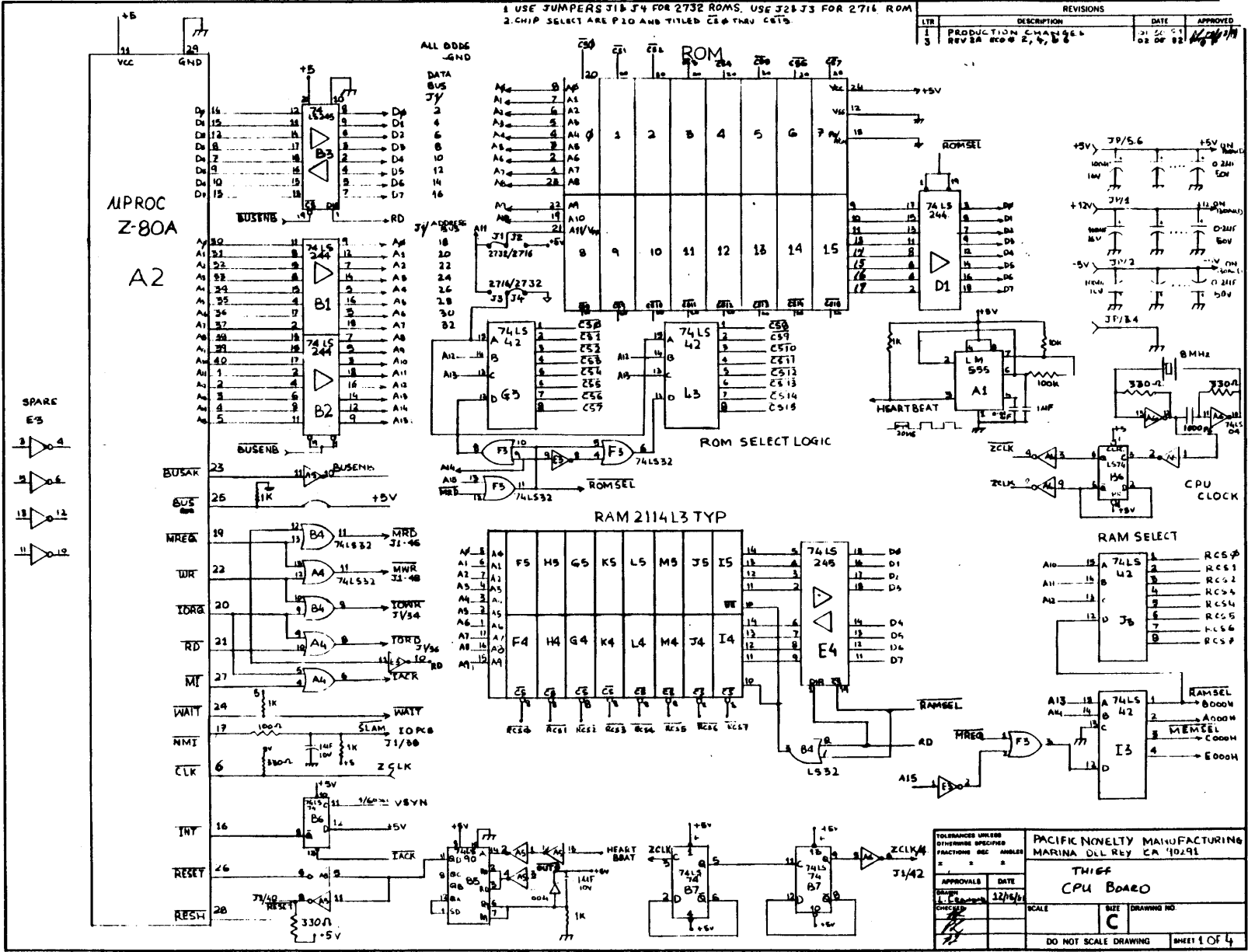

1 USE JUMPERS J1 & J4 FOR 2732 ROMS. USE J2 & J3 FOR 2714 ROM
 2. CHIP SELECT ARE P10 AND TITLED CS# THRU CS7.

REVISIONS			
LTR	DESCRIPTION	DATE	APPROVED
1	PRODUCTION CHANGE 1	21 26 81	
3	REV 3A REV 2, 3, 4, 5	02 02 82	

TOLERANCES UNLESS OTHERWISE SPECIFIED FRACTIONS DEC ANGLES		PACIFIC NONETY MANUFACTURING MARINA DEL REY CA 90291	
APPROVALS	DATE	THIEF	CPU BOARD
DESIGNER	12/16/81	SCALE	SIZE DRAWING NO.
CHECKED		C	
DO NOT SCALE DRAWING		SHEET 1 OF 4	

© 1981 PACIFIC NONETY MANUFACTURING MARINA DEL REY CA 90291

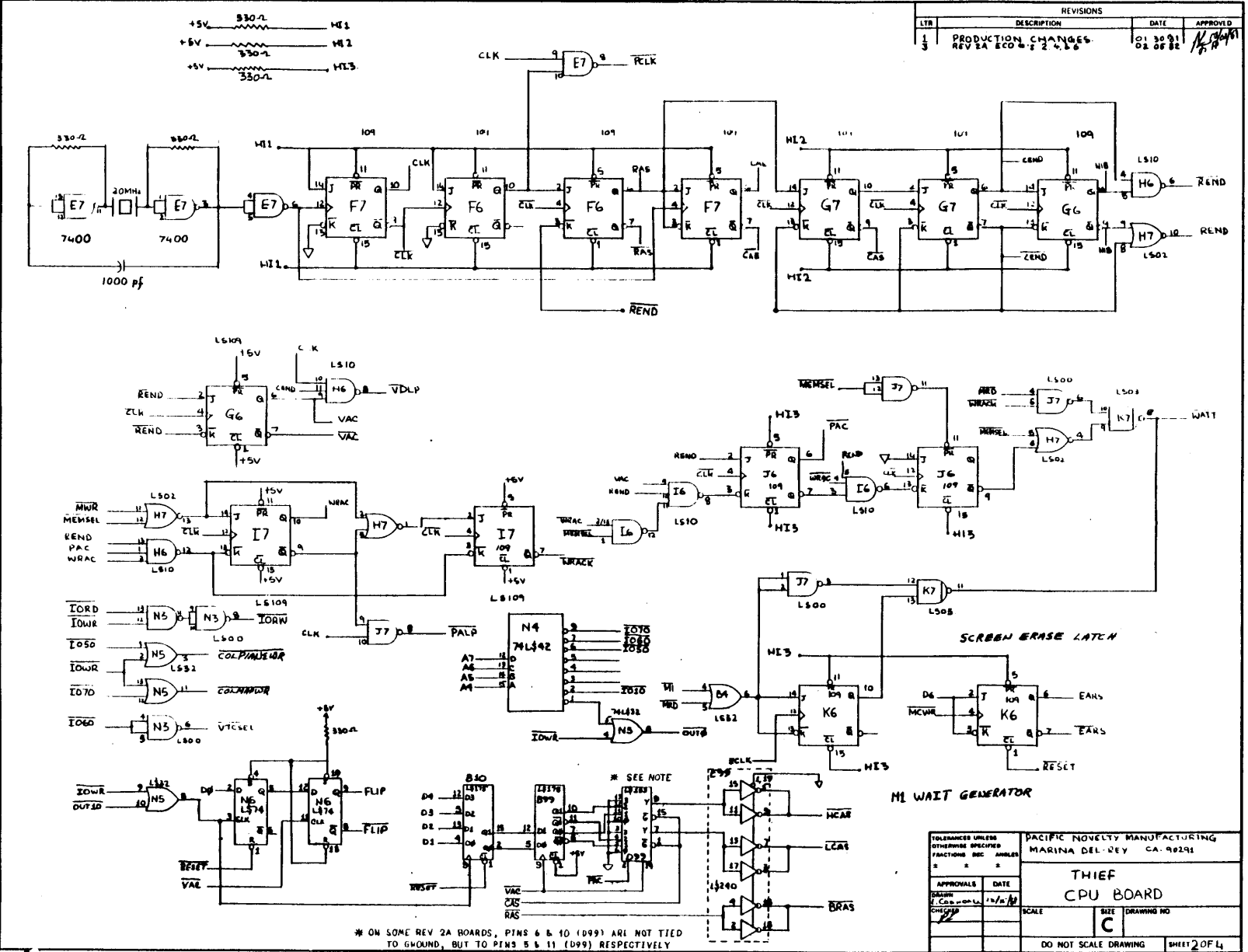

REVISIONS			
LTR	DESCRIPTION	DATE	APPROVED
1	PRODUCTION CHANGES REV 2A ECO # 2, 4, 5, 6	01 30 81 02 08 82	<i>[Signature]</i>

* ON SOME REV 2A BOARDS, PINS 6 & 10 (D99) ARE NOT TIED TO GROUND, BUT TO PINS 5 & 11 (D99) RESPECTIVELY

TOLERANCES UNLESS OTHERWISE SPECIFIED FRACTIONS DEC AMPLIES		PACIFIC NOVELTY MANUFACTURING MARINA DEL REY CA. 90291	
APPROVALS	DATE	THIEF CPU BOARD	
DESIGN I. C. S. - D. L.	11/16/80	SCALE	DRAWING NO
CHECKED		SIZE C	
		DO NOT SCALE DRAWING	SHEET 2 OF 4

REVISIONS			
LTN	DESCRIPTION	DATE	APPROVED
1	PRODUCTION CHANGES	01 30 81	
2	REV 2A ECO #1, 2, 4, 6	02 07 82	

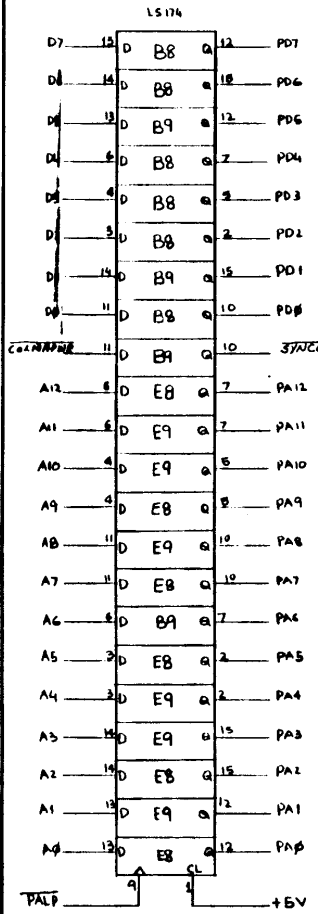

CPUI VIDEO PIPELINE REG

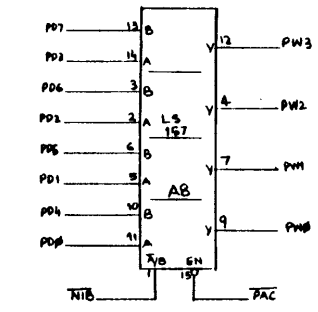

BYTE/NIBBLE DATA MUX

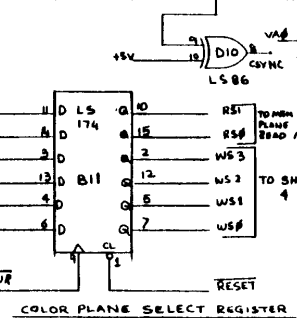
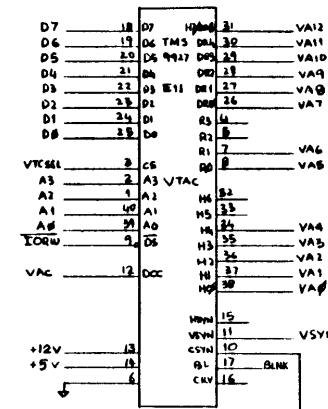

COLOR PLANE SELECT REGISTER

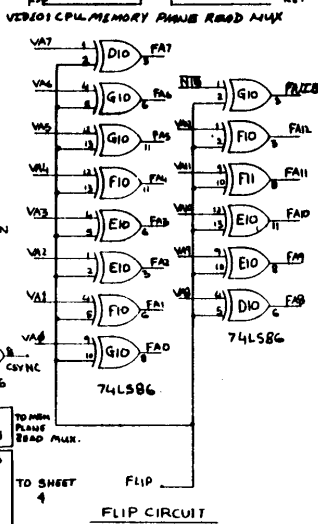
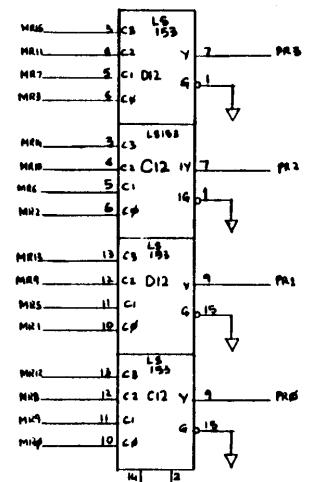

FLIP CIRCUIT

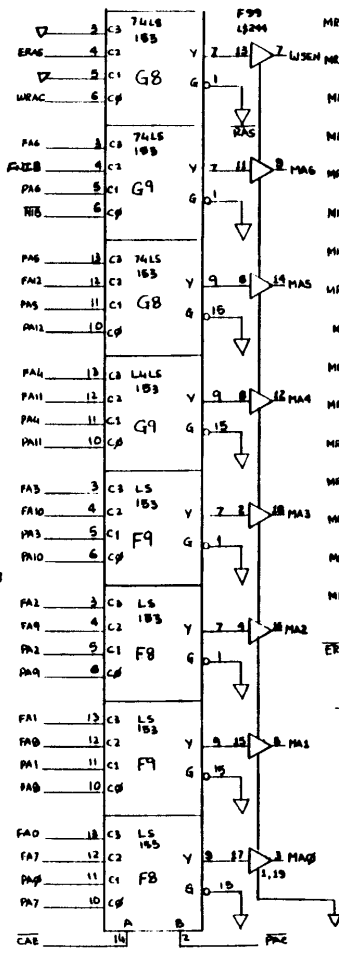

DYNAMIC ADDRESS MUX

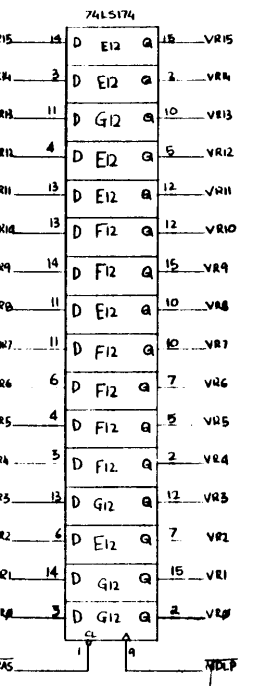

MEMORY READ PIPE LINE REGISTERS

TOLERANCES UNLESS OTHERWISE SPECIFIED		PACIFIC NOVELTY MANUFACTURING	
FRACTIONS DEC ANGLES		MARINA DEL REY CA 90241	
APPROVALS		THGF	
DATE		CPU BOARD	
DESIGN	12/14/81	SCALE	DRAWING NO.
CHECKED		SHEET	C
DO NOT SCALE DRAWING		SHEET 3 OF 4	

* PIN 15 IS CONNECTED TO EITHER HCAS OR LCAS.
SEE RAM MATRIX TABLE FOR PHYSICAL LOCATION
OF MEMORY CHIPS ON BOARD.

REVISIONS			
LTR	DESCRIPTION	DATE	APPROVED
3	PRODUCTION CHANGE REV EA ECO # 2, 4, 6	01 30 81 02 08 81	JFP

SYNCHRONIZER

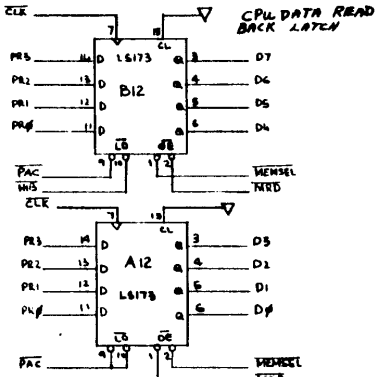
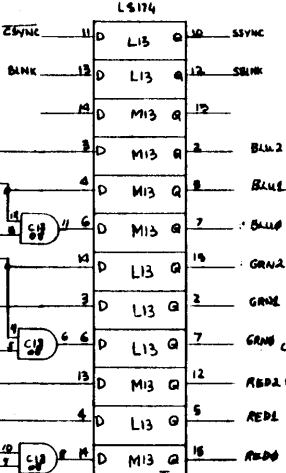
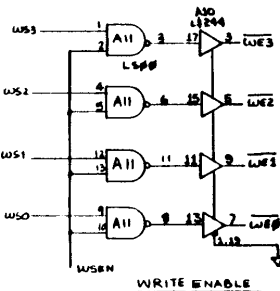
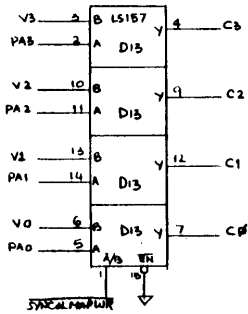
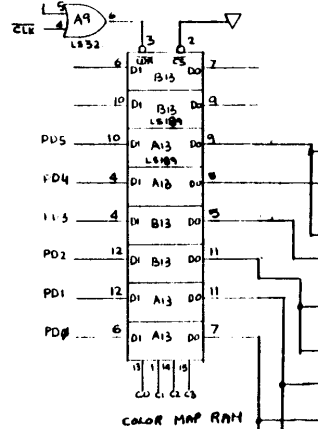

RAM MATRIX TABLE

CS	AS	CS	AS	CS	AS	CS	AS
1 HCAS	1 LCAS	1 LCAS	1 LCAS	2 HCAS	2 LCAS	2 LCAS	2 LCAS
2 HCAS	2 LCAS	2 LCAS	2 LCAS	3 HCAS	3 LCAS	3 LCAS	3 LCAS
3 HCAS	3 LCAS	3 LCAS	3 LCAS	4 HCAS	4 LCAS	4 LCAS	4 LCAS
4 HCAS	4 LCAS	4 LCAS	4 LCAS	5 HCAS	5 LCAS	5 LCAS	5 LCAS
5 HCAS	5 LCAS	5 LCAS	5 LCAS	6 HCAS	6 LCAS	6 LCAS	6 LCAS
6 HCAS	6 LCAS	6 LCAS	6 LCAS	7 HCAS	7 LCAS	7 LCAS	7 LCAS

NUMBERS ARE MR(DATA BITS).
TABLE IS SET UP FOR REFERENCE
WITH CPU POWER CABLE TO REAR.

VIDEO RAM

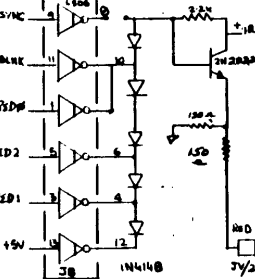
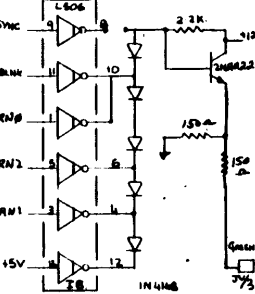
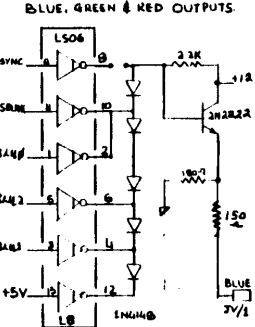
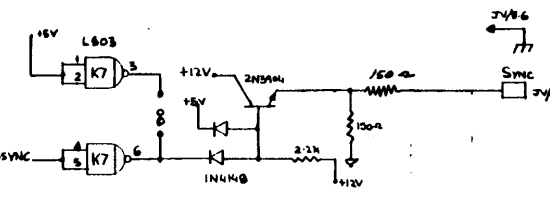
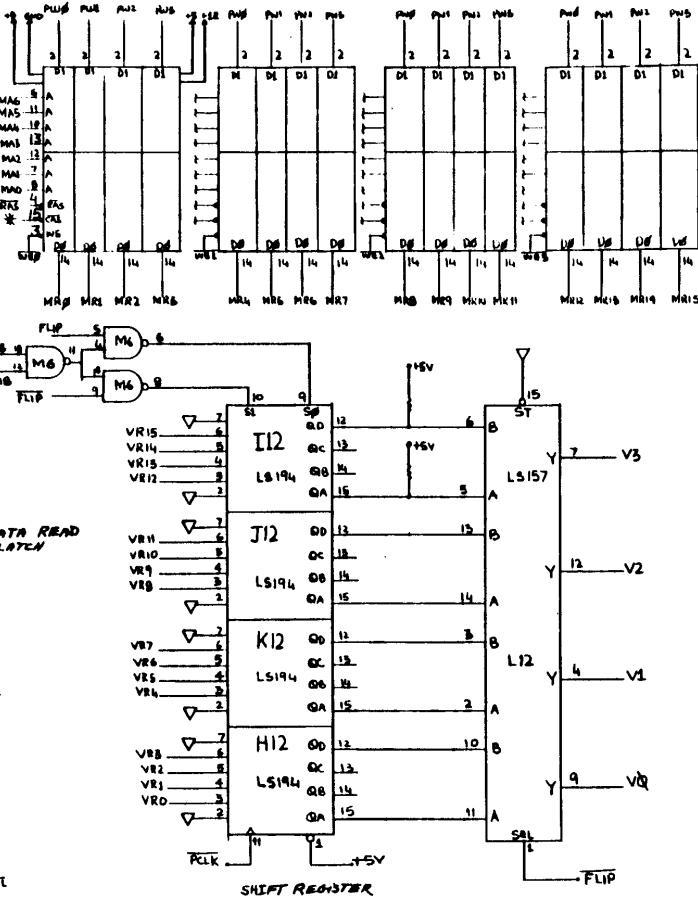

TOLERANCES UNLESS OTHERWISE SPECIFIED			
FRACTIONS	DEC	ANGLES	
2	2	2	
APPROVALS	DATE		
DESIGNER	DATE		
CHECKER	DATE		
SCALE	SIZE	DRAWING NO	
	C		
DO NOT SCALE DRAWING			SHEET 4 OF 4

PACIFIC NOVELTY MANUFACTURING
MARINA DEL REY CA. 90291

THIEF

CPU BOARD

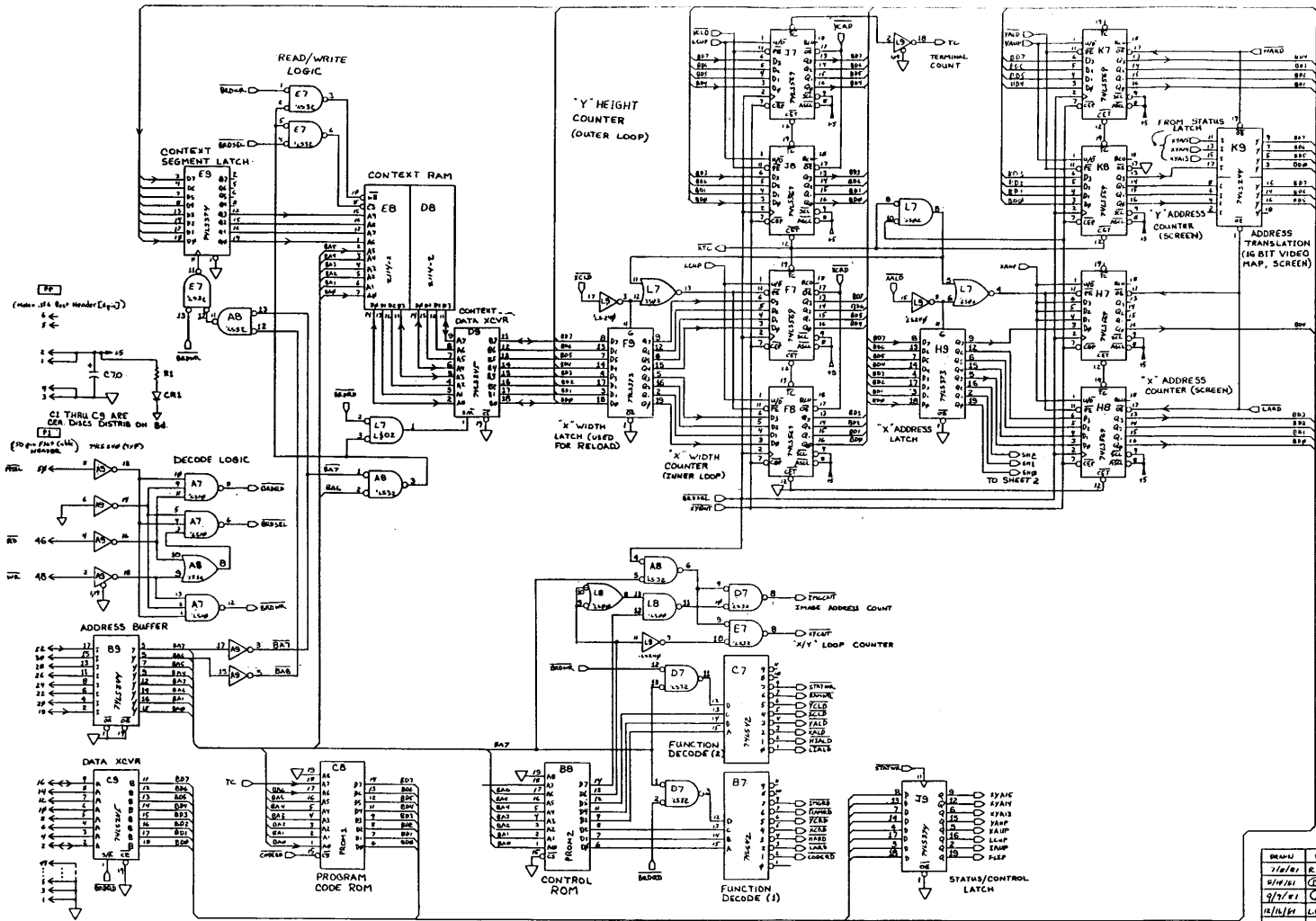

MNEMONICS TABLE

READ	7	BUFFERED ADDRESS 6 THEN 7
RWD	7	BUFFERED DATA 6 THEN 7
RDRD	7	BOARD READ
RDSL	7	BOARD SELECT
RDRW	7	BOARD WRITE
SLG	7	BUFFERED ADDRESS 6 NOT 7
SLT	7	BUFFERED ADDRESS 7 NOT 6
CODERD	7	CODE READ
CLIP	7	CLIP BOTH ENDS OF BARREL
HLRD	7	HIGH ADDRESS READ
HLALD	7	HIGH ADDRESS LOAD
SLUP	7	STATUS ADDRESS COUNT UP
SLMRD	7	STATUS READ
LARD	7	LOW ADDRESS READ
LALD	7	LOW ADDRESS LOAD
LRWR	7	RAM READ
LRWR	7	RAM WRITE
STATWR	7	STATUS WRITE
SLUP	7	"X" ADDRESS COUNT UP
XCLD	7	"X" COUNTER LOAD
XCRD	7	"X" COUNTER READ
XALD	7	"X" ADDRESS LOAD
XVAL	7	"X" ADDRESS 13
XVALA	7	"X" ADDRESS 14
XVALB	7	"X" ADDRESS 15
XVALC	7	"X" ADDRESS 16
XVALD	7	"X" ADDRESS 17
XVALE	7	"X" ADDRESS 18
XVALF	7	"X" ADDRESS 19
XVALG	7	"X" ADDRESS 20
XVALH	7	"X" ADDRESS 21
XVALI	7	"X" ADDRESS 22
XVALJ	7	"X" ADDRESS 23
XVALK	7	"X" ADDRESS 24
XVALL	7	"X" ADDRESS 25
XVALM	7	"X" ADDRESS 26
XVALN	7	"X" ADDRESS 27
XVALO	7	"X" ADDRESS 28
XVALP	7	"X" ADDRESS 29
XVALQ	7	"X" ADDRESS 30
XVALR	7	"X" ADDRESS 31
XVALS	7	"X" ADDRESS 32
XVALT	7	"X" ADDRESS 33
XVALU	7	"X" ADDRESS 34
XVALV	7	"X" ADDRESS 35
XVALW	7	"X" ADDRESS 36
XVALX	7	"X" ADDRESS 37
XVALY	7	"X" ADDRESS 38
XVALZ	7	"X" ADDRESS 39
XVALAA	7	"X" ADDRESS 40
XVALAB	7	"X" ADDRESS 41
XVALAC	7	"X" ADDRESS 42
XVALAD	7	"X" ADDRESS 43
XVALAE	7	"X" ADDRESS 44
XVALAF	7	"X" ADDRESS 45
XVALAG	7	"X" ADDRESS 46
XVALAH	7	"X" ADDRESS 47
XVALAI	7	"X" ADDRESS 48
XVALAJ	7	"X" ADDRESS 49
XVALAK	7	"X" ADDRESS 50
XVALAL	7	"X" ADDRESS 51
XVALAM	7	"X" ADDRESS 52
XVALAN	7	"X" ADDRESS 53
XVALAO	7	"X" ADDRESS 54
XVALAP	7	"X" ADDRESS 55
XVALAQ	7	"X" ADDRESS 56
XVALAR	7	"X" ADDRESS 57
XVALAS	7	"X" ADDRESS 58
XVALAT	7	"X" ADDRESS 59
XVALAU	7	"X" ADDRESS 60
XVALAV	7	"X" ADDRESS 61
XVALAW	7	"X" ADDRESS 62
XVALAX	7	"X" ADDRESS 63
XVALAY	7	"X" ADDRESS 64
XVALAZ	7	"X" ADDRESS 65
XVALAA	7	"X" ADDRESS 66
XVALAB	7	"X" ADDRESS 67
XVALAC	7	"X" ADDRESS 68
XVALAD	7	"X" ADDRESS 69
XVALAE	7	"X" ADDRESS 70
XVALAF	7	"X" ADDRESS 71
XVALAG	7	"X" ADDRESS 72
XVALAH	7	"X" ADDRESS 73
XVALAI	7	"X" ADDRESS 74
XVALAJ	7	"X" ADDRESS 75
XVALAK	7	"X" ADDRESS 76
XVALAL	7	"X" ADDRESS 77
XVALAM	7	"X" ADDRESS 78
XVALAN	7	"X" ADDRESS 79
XVALAO	7	"X" ADDRESS 80
XVALAP	7	"X" ADDRESS 81
XVALAQ	7	"X" ADDRESS 82
XVALAR	7	"X" ADDRESS 83
XVALAS	7	"X" ADDRESS 84
XVALAT	7	"X" ADDRESS 85
XVALAU	7	"X" ADDRESS 86
XVALAV	7	"X" ADDRESS 87
XVALAW	7	"X" ADDRESS 88
XVALAX	7	"X" ADDRESS 89
XVALAY	7	"X" ADDRESS 90
XVALAZ	7	"X" ADDRESS 91
XVALAA	7	"X" ADDRESS 92
XVALAB	7	"X" ADDRESS 93
XVALAC	7	"X" ADDRESS 94
XVALAD	7	"X" ADDRESS 95
XVALAE	7	"X" ADDRESS 96
XVALAF	7	"X" ADDRESS 97
XVALAG	7	"X" ADDRESS 98
XVALAH	7	"X" ADDRESS 99
XVALAI	7	"X" ADDRESS 100

DATE	BY	PROJECT NAME	MANUFACTURING
7/18/81	R. M. ...	PARALLEL DEL. BY CA. 1001	① 181
9/18/81	...	THIEF	
12/11/81	L. ...	CO-PROCESSOR	
			SHEET 1 OF 2

B08-7
TO SHEET 2

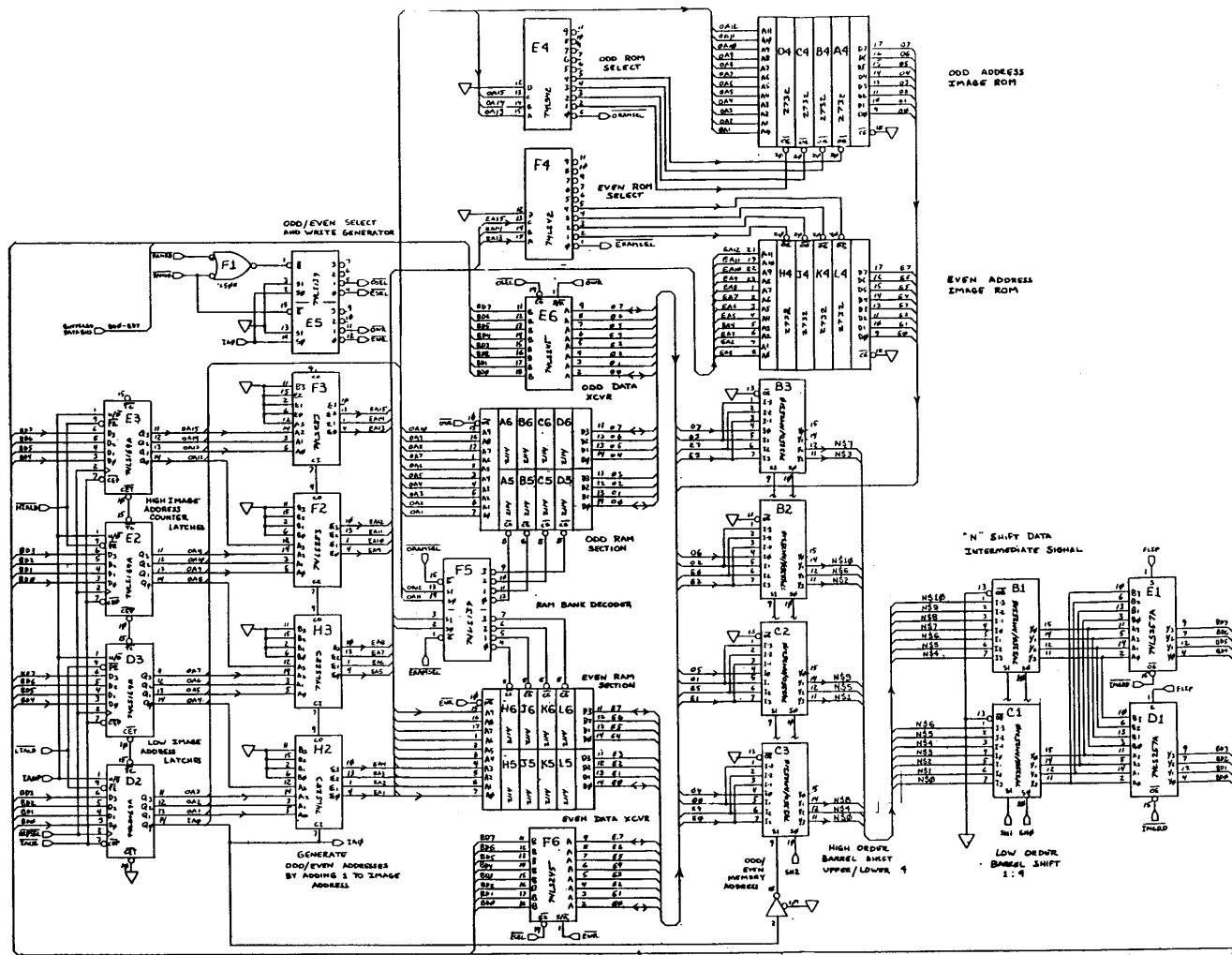

DRAWN	BY	PACIFIC NOVELTY MANUFACTURING
7/17/81	RPM	Menlo Park, CA 94025 ©1981
8/17/81	GA	THIEF
11/14/81	L. E. GARDNER	CU PROCESSOR
SHEET 2 OF 2		

PB0 TO PB8 ARE 49K TO 6N0
ONE PULL DOWN SWITCH ONLY

REVISIONS			
LTR	DESCRIPTION	DATE	APPROVED
1	PRODUCTION CHANGES	01.29.01	[Signature]

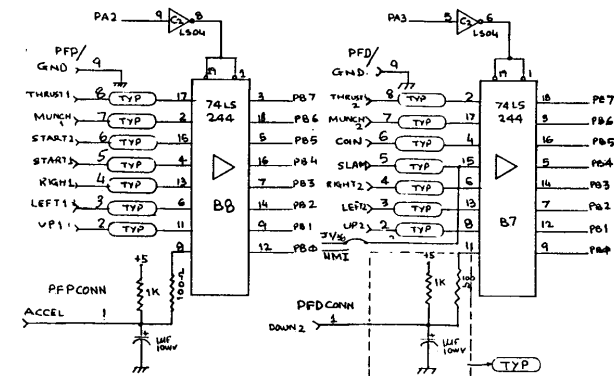
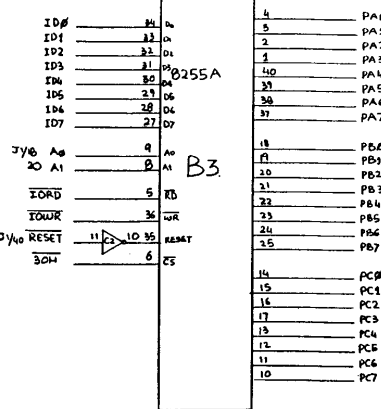
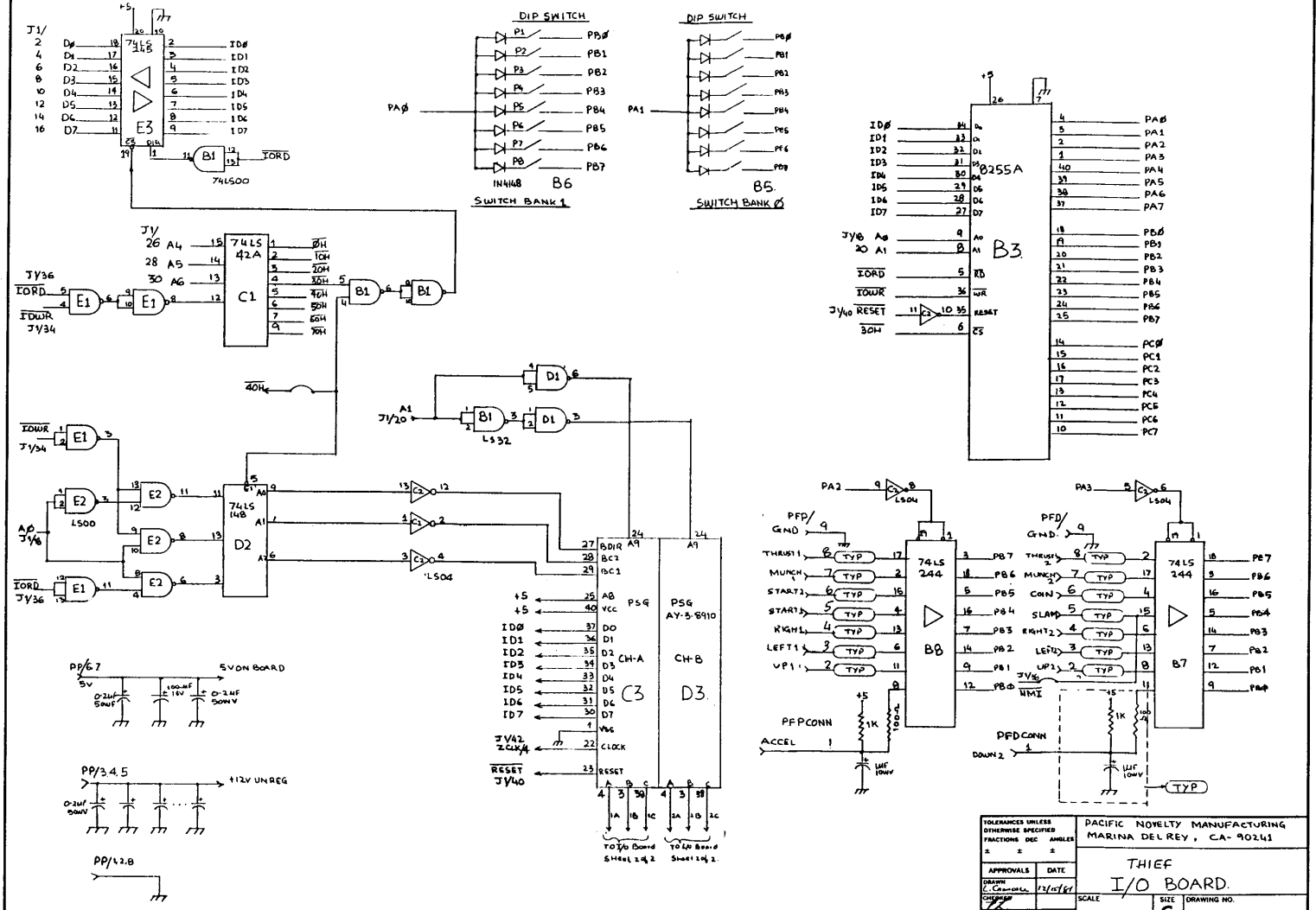

TOLERANCES UNLESS OTHERWISE SPECIFIED		PACIFIC NOVELTY MANUFACTURING	
FRACTIONS DEC ANGLES		MARINA DEL REY, CA-90241	
±	±	THIEF	
APPROVALS DATE		I/O BOARD	
DESIGN	DATE	SCALE	SHEET DRAWING NO.
C. C. C.	12/01/01		C
CHANGES			
DO NOT SCALE DRAWING		SHEET 1 OF 2	

© SHIP GRAPHICS, INC. REVISION NO. 0021

REVISIONS			
LTR	DESCRIPTION	DATE	APPROVED
1	PRODUCTION CHANGES	01 30 81	<i>[Signature]</i>

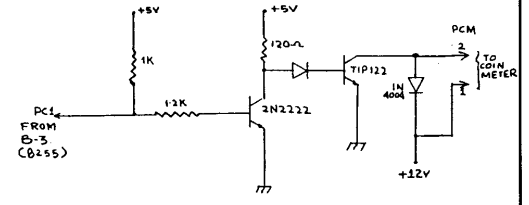
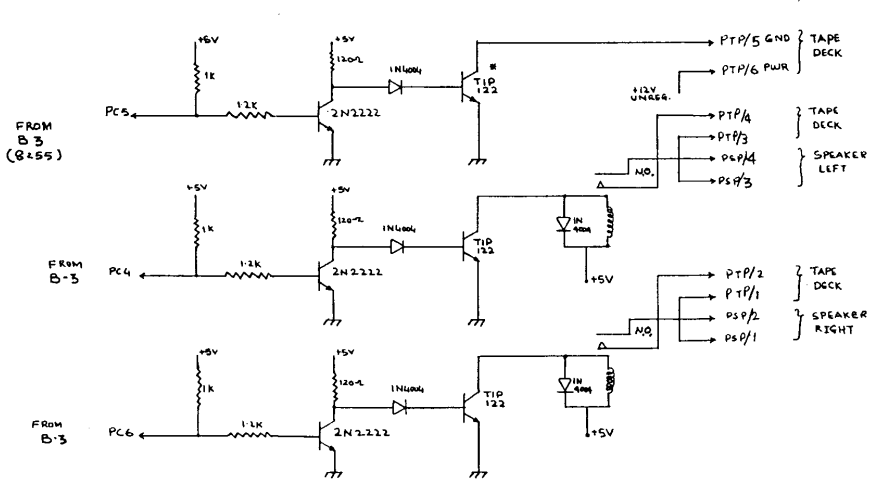
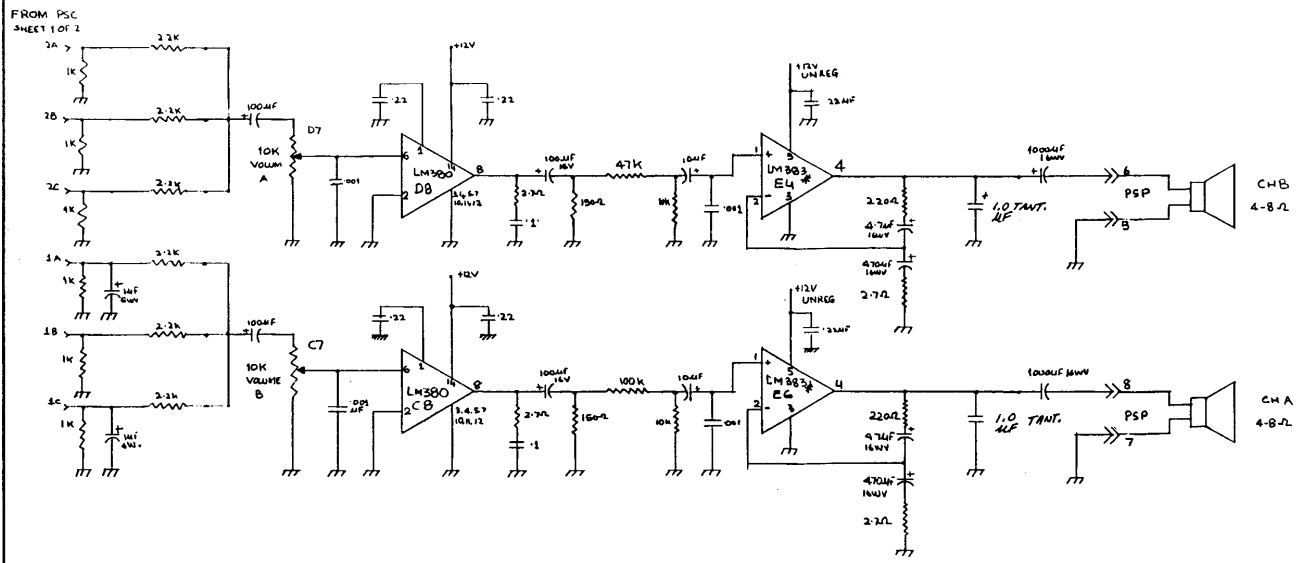

* HEAT SINK

TOLERANCES UNLESS OTHERWISE SPECIFIED		PACIFIC NOVELTY MANUFACTURING	
±	°	MARINA DEL REY, CA. 90191	
APPROVALS DATE		THIEF	
DRAWN	DATE	I/O BOARD	
<i>[Signature]</i>	12/18/81	SCALE	SERIAL DRAWING NO.
			C
DO NOT SCALE DRAWING		SHEET 2 OF 2	

© 1981 PACIFIC NOVELTY MANUFACTURING, INC. NUMBER NO. 2081

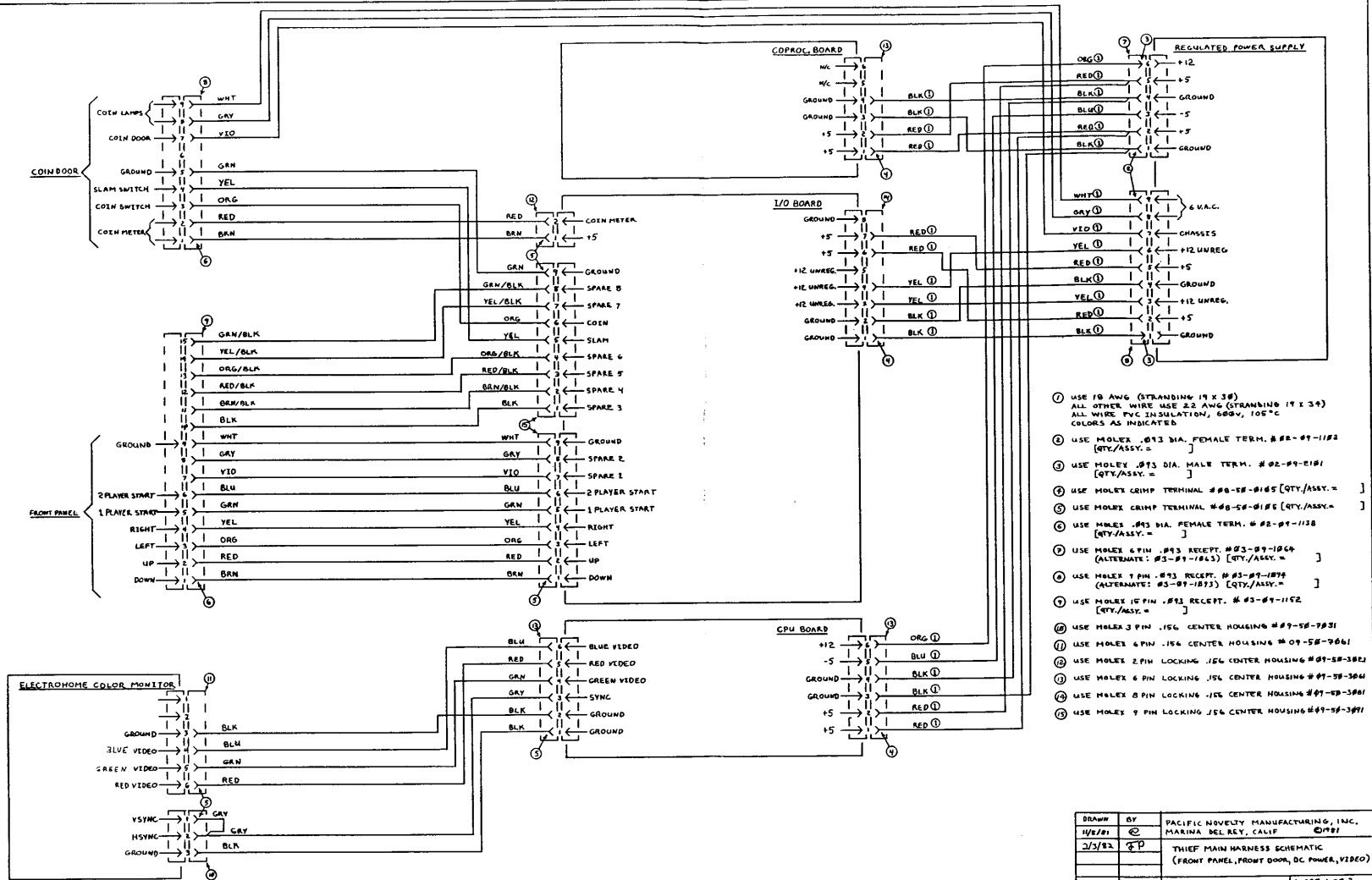

- ① USE 18 AWG (STRANDING 19 X 38)
ALL OTHER WIRE USE 22 AWG (STRANDING 19 X 34)
ALL WIRE PVC INSULATION, 600V, 105°C
COLORS AS INDICATED
- ② USE MOLEX .093 DIA. FEMALE TERM. # 02-09-1182 [QTY/ASSY. =]
- ③ USE MOLEX .093 DIA. MALE TERM. # 02-09-1181 [QTY/ASSY. =]
- ④ USE MOLEX CRIMP TERMINAL # 08-58-0185 [QTY/ASSY. =]
- ⑤ USE MOLEX CRIMP TERMINAL # 08-58-0186 [QTY/ASSY. =]
- ⑥ USE MOLEX .093 DIA. FEMALE TERM. # 02-09-1138 [QTY/ASSY. =]
- ⑦ USE MOLEX 6 PIN .093 RECEPT. # 03-09-1064 (ALTERNATE: # 03-09-1063) [QTY/ASSY. =]
- ⑧ USE MOLEX 4 PIN .093 RECEPT. # 03-09-1079 (ALTERNATE: # 03-09-1073) [QTY/ASSY. =]
- ⑨ USE MOLEX 10 PIN .093 RECEPT. # 03-09-1152 [QTY/ASSY. =]
- ⑩ USE MOLEX 3 PIN .156 CENTER HOUSING # 09-58-7031
- ⑪ USE MOLEX 6 PIN .156 CENTER HOUSING # 09-58-7061
- ⑫ USE MOLEX 2 PIN LOCKING .156 CENTER HOUSING # 09-58-38E2
- ⑬ USE MOLEX 6 PIN LOCKING .156 CENTER HOUSING # 09-58-38W1
- ⑭ USE MOLEX 8 PIN LOCKING .156 CENTER HOUSING # 09-58-38W1
- ⑮ USE MOLEX 9 PIN LOCKING .156 CENTER HOUSING # 09-58-38W1

DRAWN	BY	PACIFIC NOVELTY MANUFACTURING, INC.
1/6/81	©	MARINA DEL REY, CALIF
2/3/82	SP	©1981
THIEF MAIN HARNESS SCHEMATIC (FRONT PANEL, FRONT DOOR, DC POWER, VIDEO)		
SHEET 1 OF 2		

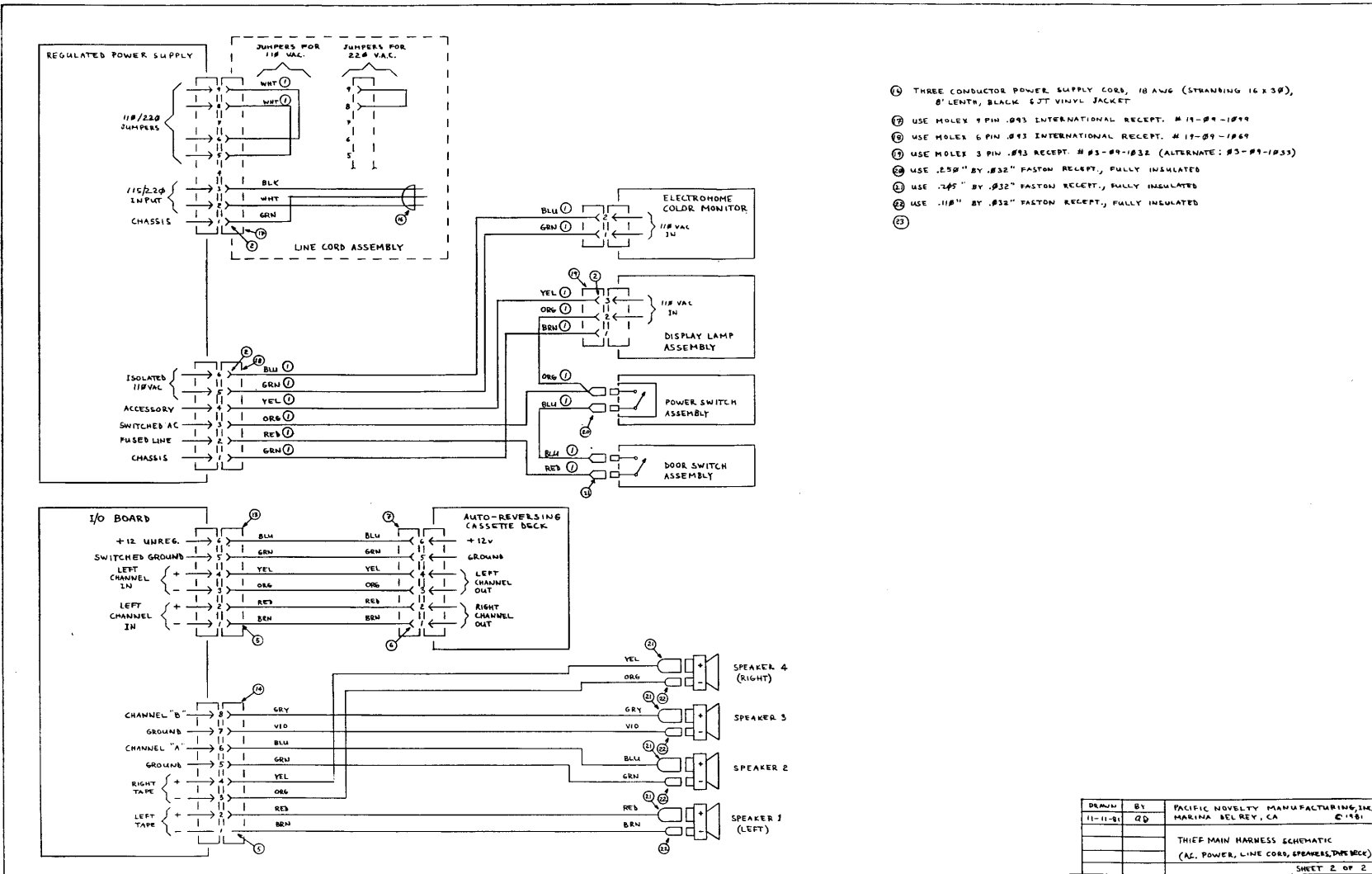

- ① USE .187 x .060 PASTOR RECEPT (10-24 AM), FULLY ENCAPULATED [QTY. PER ASSY. = 12.]
- ② USE MOLEX 03-09-2151 PLUG [QTY. PER ASSY. = 1]
- ③ USE MOLEX MALE .093 DIAM TERM. #C-09-2136 [QTY. PER ASSY. = 7]
- ④ ALL WIRE USE .32 AWG, STRANDING 19 x 34, PVC INSULATION, 600V, 105°C COLOR AS INDICATED

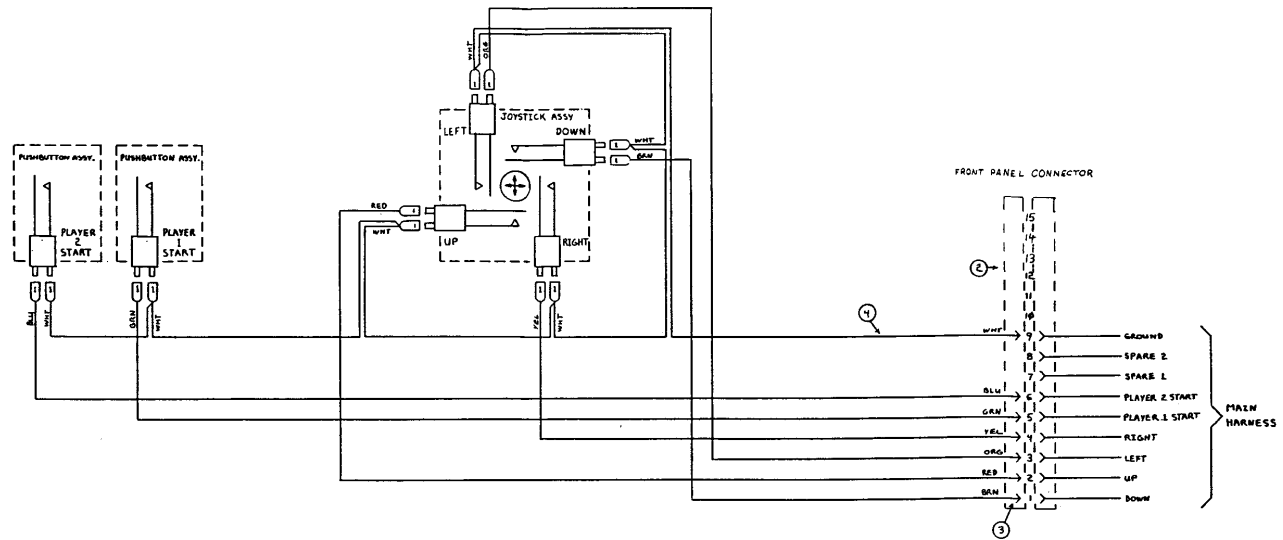

DRAWN	BY	PACIFIC NOVELTY MANUFACTURING, INC.
11/2/71	②	HARDEN BEL REY, CA. ©1971
2/1/82	SP	THELF FRONT PANEL HARNESS SCHEMATIC
		SHEET 1 OF 1

- ① USE .187" x .020" FASTON RECEPT. (20-24 AWG), FULLY INSULATED [QTY. PER ASSY. = 4]
- ② USE .205" x .032" FASTON RECEPT. (20-24 AWG), FULLY INSULATED [QTY. PER ASSY. = 4]
- ③ USE MOLEX #3-09-2092 PLUG [QTY. PER ASSY. = 1]
- ④ USE MOLEX #2-09-2136 MALE .093 DIAM. TERM. [QTY. PER ASSY. = 8]
- ⑤ USE MOLEX #3-09-1932 RECEPT. [QTY. PER ASSY. = 1]
- ⑥ USE MOLEX #2-09-1138 FEMALE .093 DIAM. TERM. [QTY. PER ASSY. = 2]
- ⑦ USE #8 STD. SIZE. RING TERMINAL.
- ⑧ ALL WIRE, USE 22 AWG (19-34 STRAN BNG), PVC INSULATION, 600V, 105°C. COLORS AS INDICATED.
- ⑨ USE .205" x .020" FASTON RECEPT. (20-24 AWG), FULLY INSULATED [QTY. PER ASSY. = 2]

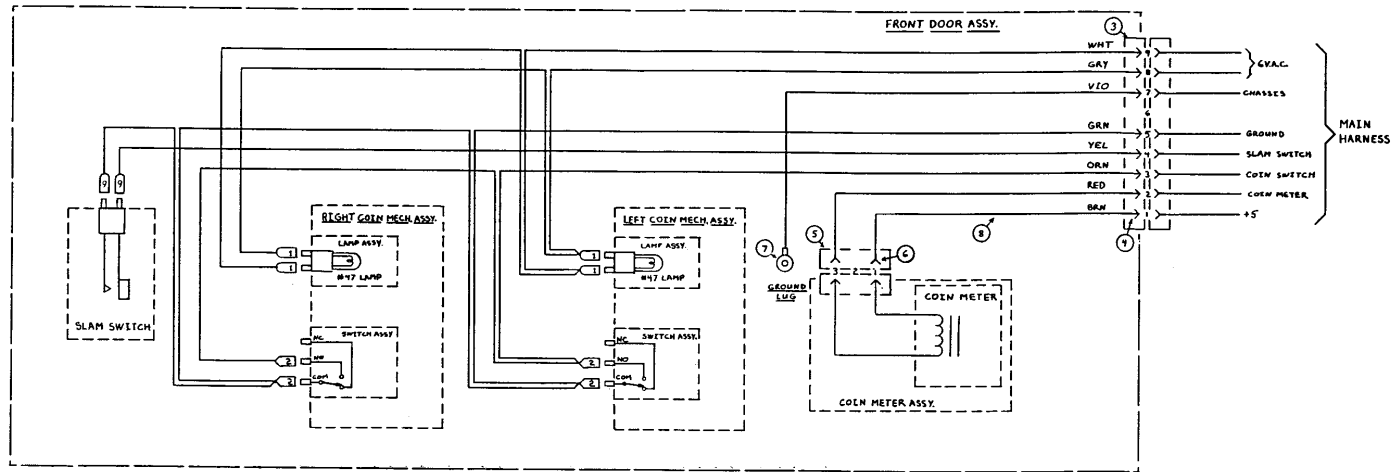

DRW	BY	PACIFIC NOVELTY MANUFACTURING, INC.
1/27/81	CS	MARION DEL REY, CA. ©1981
2/17/82	shp	THIEF COIN DOOR HARNESS SCHEMATIC
		SHEET 1 OF 1

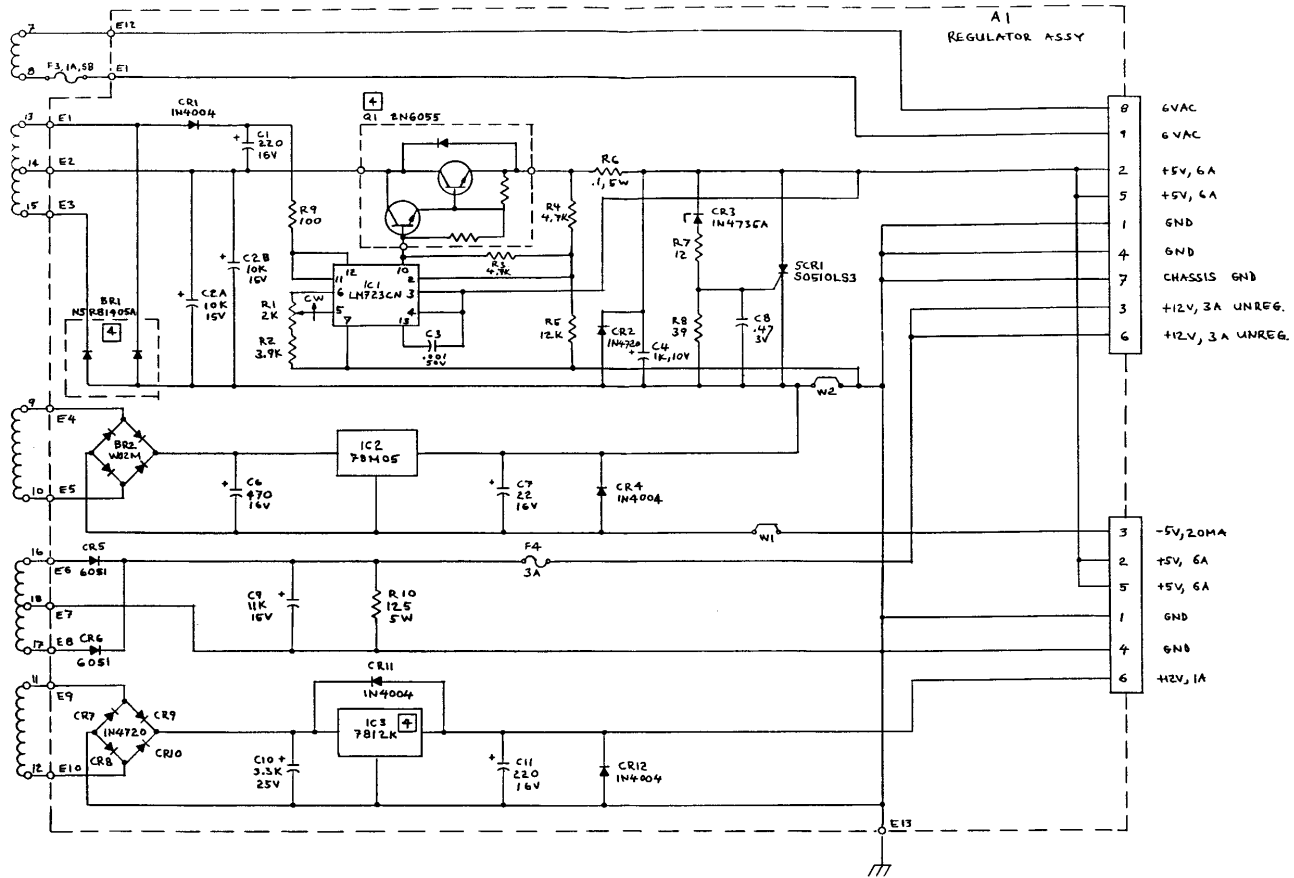

- 4 COMPONENT MOUNTED ON CHASSIS.
 1. ALL RESISTANCE VALUES IN OHMS $\pm 5\%$, $\frac{1}{2}W$.
 2. ALL CAPACITANCE VALUES IN MICROFARADS.

NOTES: UNLESS OTHERWISE SPECIFIED

		PACIFIC NOVELTY MANUFACTURING MARINA DEL REY, CA. 90405	
Drawn by	DATE	COMPUTER PORTRAIT REGULATOR SCHEMATIC	
CV	70-20		
		REV	5
SHEET 1 OF 1			

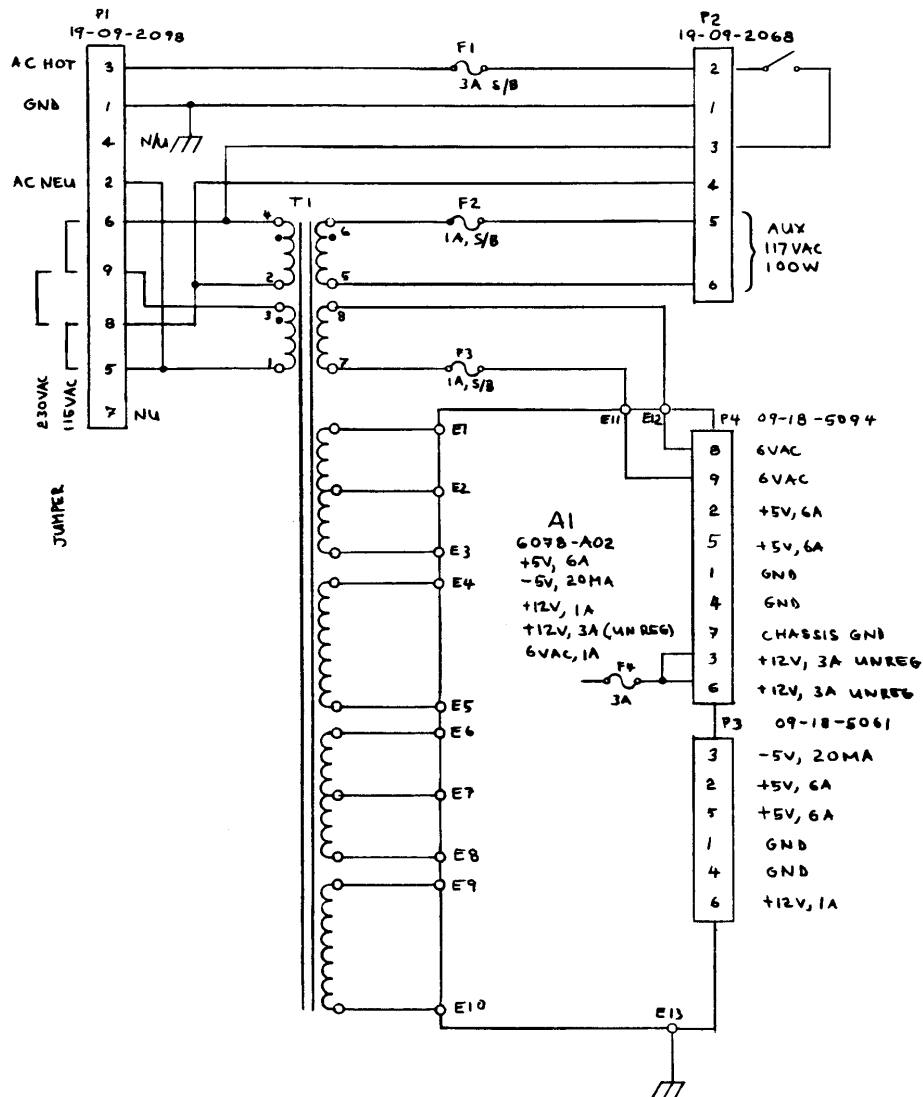

NOTES: UNLESS OTHERWISE SPECIFIED

DRAWN BY: DATE		PACIFIC NOVELTY MANUFACTURING MARIANA DEL REY CA. 90291	
68 70-2-01		TITLE COMPUTER PORTRAIT POWER SUPPLY SCHEMATIC	
		SIZE D	DWG. NO.
		SHEET 1 OF 1	