

WORLD KICKS

UPDATE 1

**MODIFICATION TO THE
KICKER ASSEMBLY**

Ensure that the game is working correctly, and rectify any problems (except kicker problems) before commencing this work.

Ensure that the game is switched OFF and the power is disconnected before removing any parts.

Separate the Kicker and Monitor Cabinets.

1. Remove 4 off hex head screws (M6x20), with spring washers.
2. Raise the level adjusters on the Kicker Cabinet and remove the adjustable feet holders before moving it away from the Monitor Cabinet. (Failure to raise the adjusters may cause the adjusters to be bent or damaged).
3. Take care when moving the Kicker Cabinet not to stretch the looms before disconnecting the connectors.

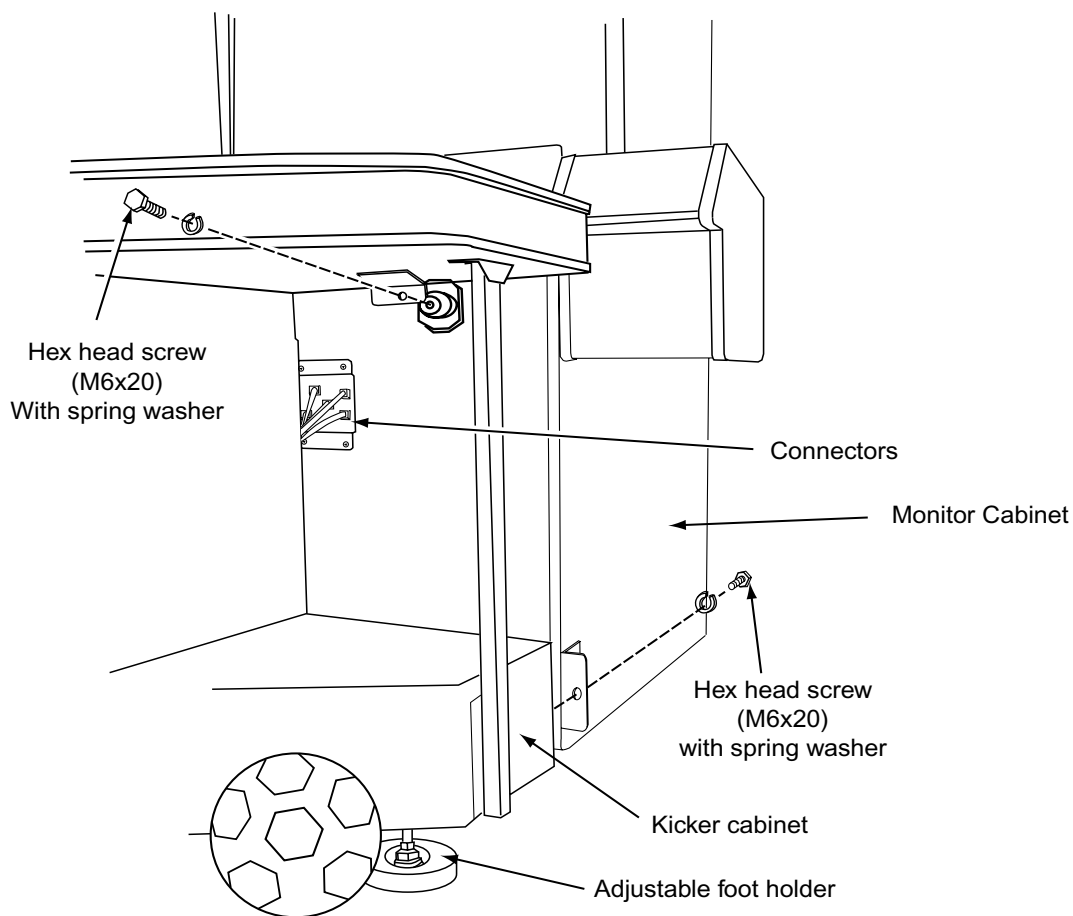

Remove the Kicker Assemblies.

1. Remove 2 off whizz nuts (M10) and remove the rear Fixing Bracket.

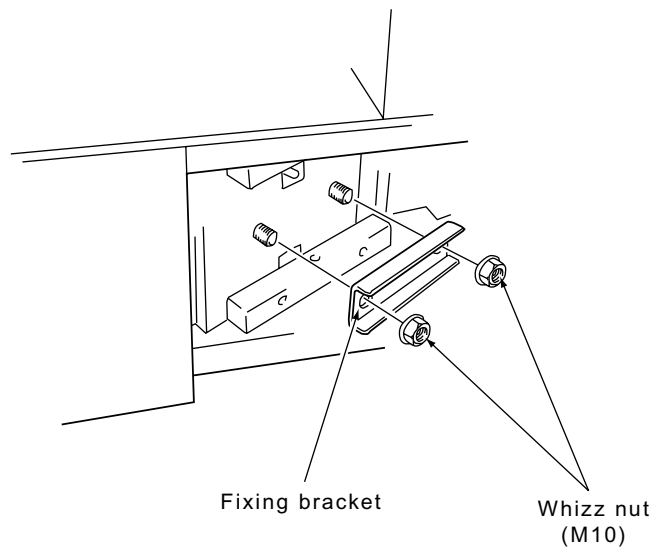

2. Remove 4 off torx security screw (M6x20), 4 off socket button head screw (M6x20) and remove the Front Protectors (left and right). Remove 2 off torx security screw (M6x20) and remove the Front Protector (centre).
3. Disconnect the connectors from the Kicker Assemblies.
4. Remove 2 off hex head screw (M10x30) from the front of each Kicker Assy.

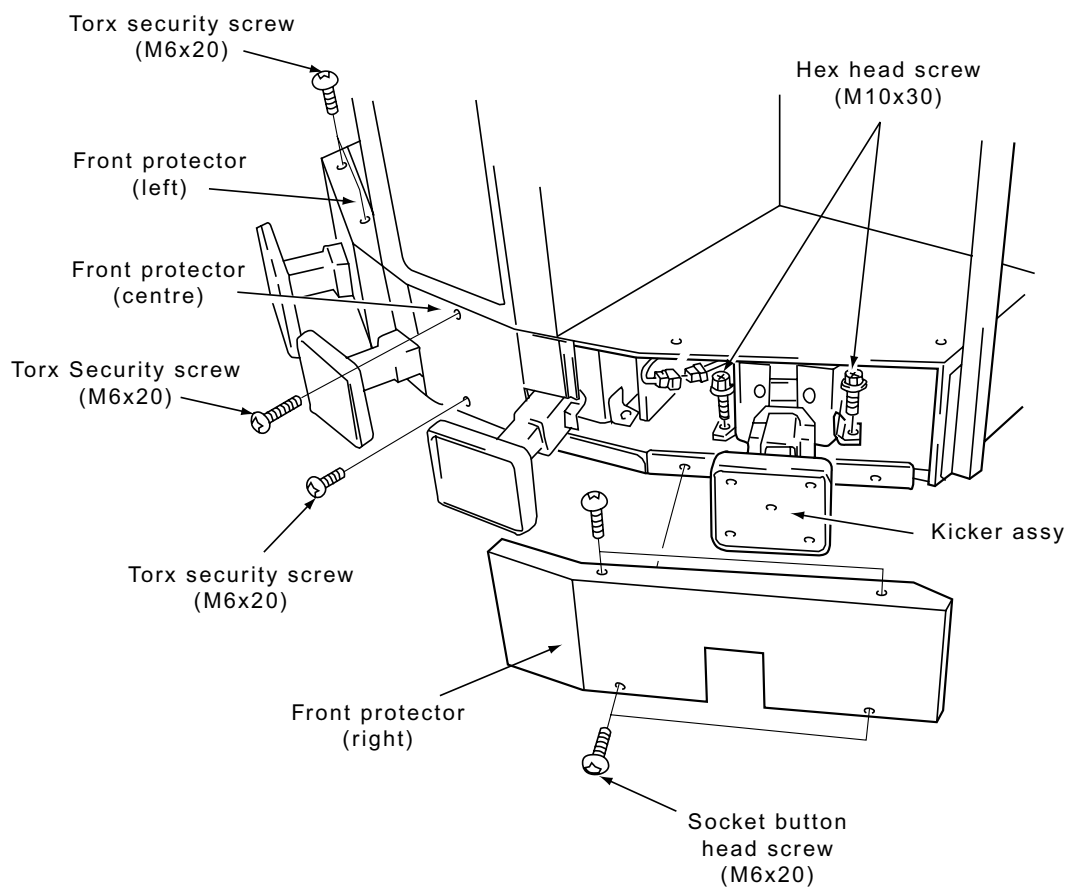

5. Withdraw the Kicker Assy from the front of the cabinet.

Fitting the New Nylon Washer

1. Remove 1 off Full nut (M6) and remove the Spring Shaft complete with Spring, and Spring Ends.

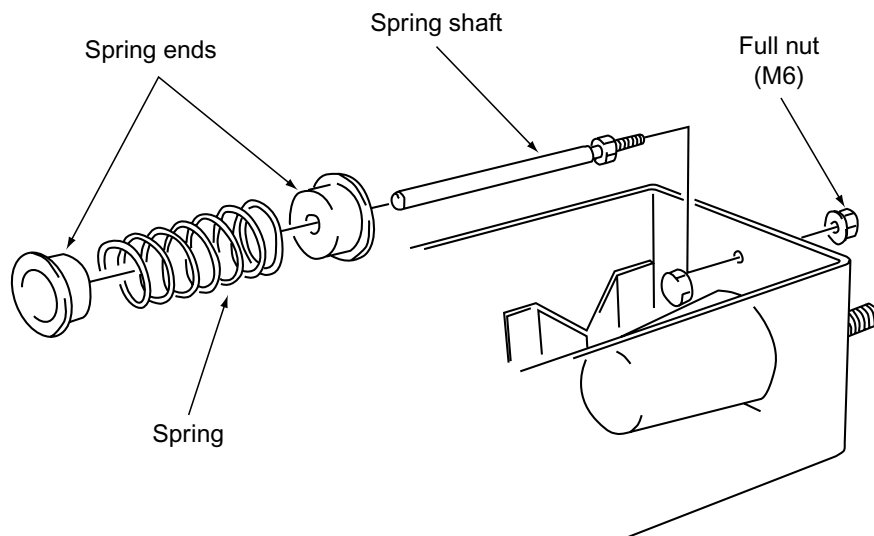

2. When reassembling the new Spring Shaft refit the spring ends in the opposite positions (front spring end refitted to the back and the back spring end refitted to the front).
3. Fit the new Nylon Washer on to the spring shaft in front of the front spring end and refit the Spring Shaft to the Kicker Assembly.
4. Refit the shaft to the Kicker Assembly using 1 off Whizz nut (M6) supplied and with Loctite 242 applied to the thread.

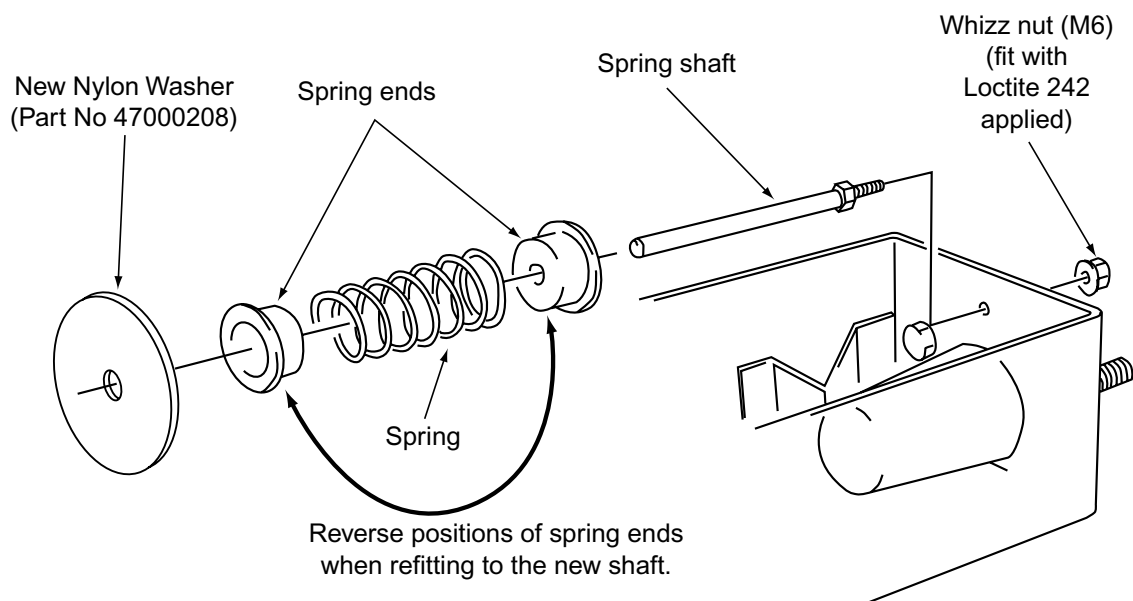

Note: When tightening the Whizz nut ensure that the nut welded to the shaft is retained with a spanner to ensure that the Whizz nut is fully tightened. Failure to tighten the Whizz nut fully may allow the shaft to come loose during game play causing damage to the shaft.

Re-assembly and Testing

1. Refit the Kicker Assemblies to the cabinet.
2. Refit the Front Protectors.
3. Rejoin the Kicker Cabinet to the Monitor Cabinet.
(Take care not to trap any wires when rejoining the cabinets).
4. Refit the Adjustable Feet Holders and lower the Level Adjusters.
5. Re-initialize the game.

The following operation must always be performed after replacing the NAOMI Game PCB, Joystick Potentiometers or initializing the backup data..

The game will not operate correctly if these adjustments are not made.

- a) Slide the TEST switch ON while pressing and holding the SERVICE switch. The following screen is displayed.
- b) Ensure that all joysticks are in their central position, then press the Service button to initialize the setting details.

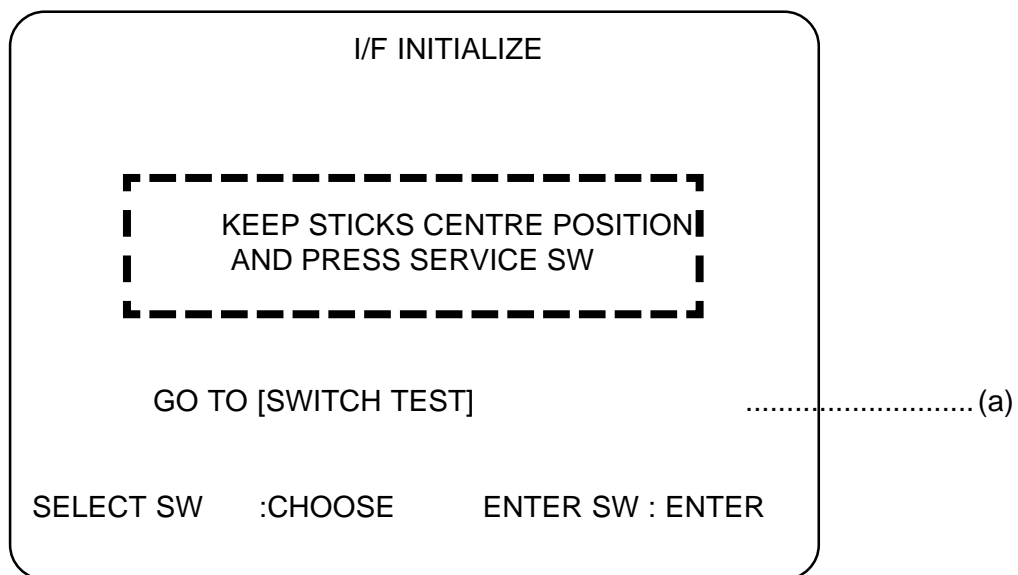

- c) Press the Enter button to go to the Switch Test and confirm correct joystick operation.
(see next page for test details)

Switch Test

When Switch Test is selected and entered from the I/F Initialize screen the following screen is displayed.

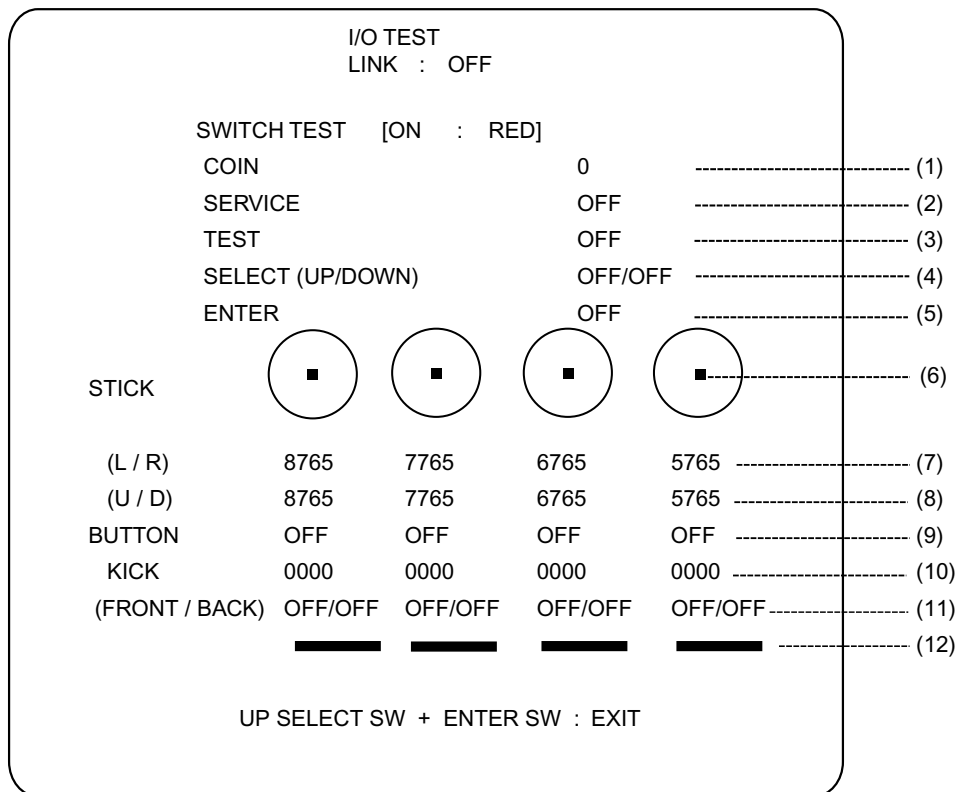

The SWITCH TEST screen displays the status of the switches.

The display changes when any of the switches are operated.

Press both Select Up switch and Enter Switch together to exit and return to the Menu.

- (1) The number increments each time a coin signal is received.
- (2) ~ (5) The display changes from OFF to ON each time the respective switch is operated.
- (6) A bar extends from the centre corresponding to the direction and deflection of the joystick.
- (7) & (8) The figure changes corresponding to the joystick angle when the joystick is tilted. The figure will change colour when the joystick is tilted to its maximum angle of deflection.
(7) is for the left/right direction, and (8) is for the forward/backward direction.
- (9) The display changes from OFF to ON when either of the start buttons are pressed.
- (10) Displays the input force of the ball assembly used during the game.
- (11) The left OFF changes to ON, (ON/OFF), when the ball is kicked gently and the right OFF changes to ON, (ON/ON), when the ball is kicked hard.
- (12) A red bar is displayed above the line when the ball is kicked. The bar length indicates the kick speed.