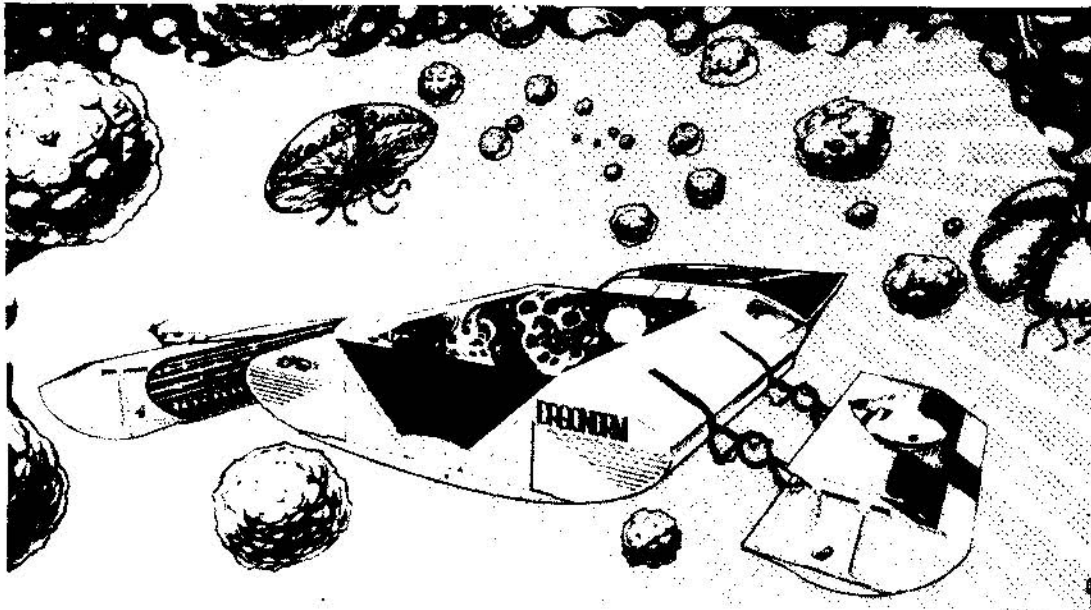


# COSMIC SERIES

# HEBER

Operation, Maintenance and Service Manual



**UNIVERSAL**

# CONTENTS

I. Features of this machine .....	1
II. How to handle and maintain this machine. ....	2
III. How to play .....	3
IV. Various optional settings. ....	4
A. Positions of dip switches .....	4
B. Setting the option (dip switches) .....	4
C. Volume controller knob .....	5
V. TV monitor .....	5
A. Adjustment of TV picture screen .....	5
VI. Upright type parts catalog .....	6
A. Component parts related to cabinet (outside) .....	6
B. Drawing of circuit board mounting positions .....	7
C. Fuses .....	7
D. Component parts related to cabinet (inside) .....	8
a) Operating panel assembly .....	8
b) Door assembly and parts list .....	9
c) Lever assembly and part list .....	10
E. Component parts related to switches and lamps in the cabinet .....	11
VII. Table type parts catalog .....	12
A. Component parts related to cabinet (outside) .....	12
B. Component parts related to cabinet (inside) .....	13
a) Inside cabinet .....	13
b) Fuses .....	14
c) Operating panel assembly .....	14
VIII. Circuit board .....	15
A. Circuit board IC location and parts list .....	15
a) Main circuit board IC location and parts list .....	15
b) Sub-circuit board IC location and parts list .....	16
c) Sound circuit board IC location and parts list .....	17
d) Sound sub-circuit board IC location and parts list .....	18
Wiring diagram (connector) .....	19
Sound block diagram .....	20
Power source block diagram .....	20
Block diagram .....	20
Schematic diagram (20" color) .....	21
Schematic diagram (14" color) .....	22
Main block diagram .....	23, 24
Postface .....	25

## REFERENCE DRAWING

Fig. 1	Positions of Dip Switches	4
Fig. 2	Positions of Volume Controller Knob	5
Fig. 3	Positions of TV Monitor Controller Knobs	5
Fig. 4	Component Parts Related to Cabinet (Outside)	6
Fig. 5	Circuit Board Mounting Positions	7
Fig. 6	Side View of Circuit Board Mounting Positions	7
Fig. 7	Position of Sound Sub-circuit Board	7
Fig. 8	Fuses	7
Fig. 9	Component Parts Related to Cabinet (Inside)	8
Fig. 10	Operating Panel Assembly	8
Fig. 11	Inside View of Door Assembly	9
Fig. 12	Lever Assembly	10
Fig. 13	Component Parts Related to Switches in the Cabinet	11
Fig. 14	Component Parts Related to Cabinet (Outside)	12
Fig. 15	Component Parts Related to Cabinet (Inside)	13
Fig. 16	Fuses in the Power Source Unit	14
Fig. 17	Fuses in the Power Circuit Board	14
Fig. 18	Operating Panel Assembly	14
Fig. 19	Main Circuit Board	15
Fig. 20	Sub-circuit Board	16
Fig. 21	Sound Circuit Board	17
Fig. 22	Sound Sub-circuit Board	18

### — WHEN ORDERING PARTS —

Since each component part is indicated by block, definitely specify both the corresponding Fig. No. and part No. within the Fig. when placing an order for it.

**UNIVERSAL**

---

## **I. FEATURES OF THIS MACHINE**

1. The game packs in excellent features capturing the hearts of players.
2. The lever control system is simple to handle.
3. At the flick of a dip switch, you can select among extended play, the number of tanks and time of appearance of an additional tank, etc.
4. High score for the day is always displayed on the screen.
5. Finely designed cabinet and fascinating acoustic effects.






## **II. HOW TO HANDLE AND MAINTAIN THIS MACHINE**

1. Since the UNIVERSAL's ZERO HOUR employs a color TV receiving set, be careful not to shake it during transit and when carrying it about.
2. Install it at a location which is not exposed to direct sunlight. In order to prevent the inside temperature rising, avoid as much as possible a location near a heater, etc.
3. Since the grounding terminal is visible, be sure to connect it to a grounding conductor.
4. Insert the power cord into the outlet and turn on the switch.
5. Even if the solid-state module seems to be out of order, do not check the circuit by means of a circuit tester, etc., since the internal voltage of the tester, etc. may sometimes break down the IC.
6. Make sure the machine is well ventiated. If the temperature of the IC and transistor is lower than 60°C, the function normally and may be considered reliable. If it exceeds 60°C, their performance cannot be guaranteed.
7. Make sure that the connector, etc. is not disconnected.
8. Whenever connecting the power cord of the solid-state module to, or disconnecting it from, the outlet, be sure to turn the power off.
9. Although the products of UNIVERSAL are manufactured with the utmost care, they may develop malfunctions when used for long periods. So, be sure to chek this machine daily.

### III. HOW TO PLAY

1. Spaceship "ZERO" can be manoeuvred in 8 directions by working the lever – destroy the meteorites by using the magazine space gun.
2. Shooting down a red meteorite awards a double score.
3. If you hit the enemy spaceship while dodging the flickering barrier, 3 enemy spaceships will counterattack launching missiles. After destroying all of them, the next barrier is removed and 3 other enemy spaceships will appear. Thus, a total of 9 enemy spaceships appear, attacking one after the another.
4. When you have shot down the 9 assaulting spaceships, a launching pad will appear below. So, carefully land your spaceship on the pad by working the lever. When pushing the FIRE button at this time, your spaceship can be raised. If you succeed in landing, you are awarded additional bonus points which are displayed on the screen.
5. The number of cleared screens is displayed by green star(s) on the lower right side. From the 10th screen on, the stars redden.

### SCORE

	Meteorite (large) .....	5 PTS
	Meteorite (middle) .....	10 PTS
	Meteorite (small) .....	15 PTS
	Enemy spaceship .....	20 PTS
	Enemy missile .....	3 PTS

## IV. VARIOUS OPTIONAL SETTINGS

### A. POSITIONS OF DIP SWITCHES

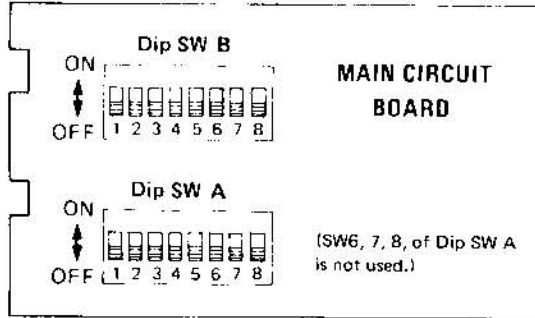


Fig. 1 Positions of Dip Switches

### B. SETTING THE OPTION (DIP SWITCHES)

[Dip Switches A]

- Setting the number of SPACESHIPS for game (SW1, 2)

Number of SPACESHIPS	SW1	SW2
2 Ships	ON	ON
3 Ships	OFF	OFF
4 Ships	OFF	ON
5 Ships	ON	OFF

- Setting the required score for an additional SPACESHIP (SW3, 4)

Score for Extra	SW3	SW4
Over 5,000 pts	OFF	OFF
Over 8,000 pts	OFF	ON
Over 10,000 pts	ON	OFF
No extra	ON	ON

- Change-over setting of the mode of game (SW5)

Style	SW5
Table	OFF
Upright	ON

- SW6, 7, 8, of SW A is not used.

[Dig Switches B]

- Setting the game charge (Coin & Credit)

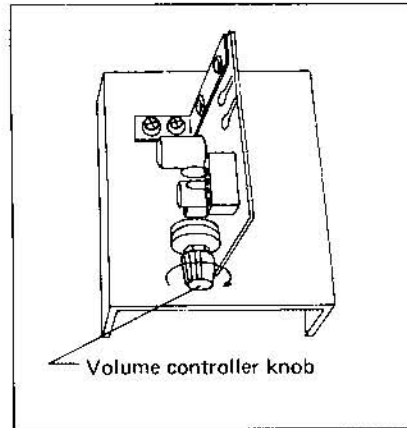
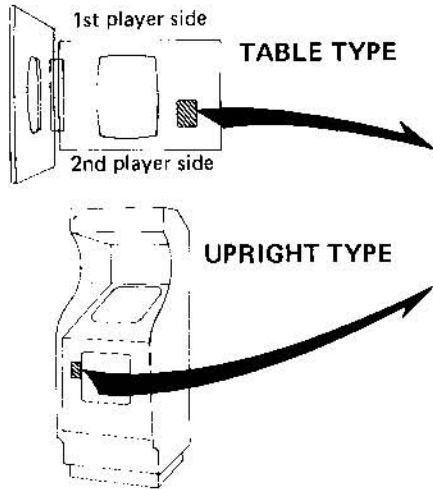
- Right chute (SW1, 2, 3, 4)

Coin	Credit	SW5	SW6	SW7	SW8
1	1	OFF	OFF	OFF	OFF
1	2	OFF	OFF	OFF	ON
1	3	OFF	OFF	ON	OFF
1	4	OFF	OFF	ON	ON
1	5	OFF	ON	OFF	OFF
2	1	OFF	ON	OFF	ON
2	3	OFF	ON	ON	OFF
3	1	OFF	ON	ON	ON
3	2	ON	OFF	OFF	OFF
4	1	ON	OFF	OFF	ON
1	1	ON	OFF	ON	OFF
1	1	ON	OFF	ON	ON
1	1	ON	ON	OFF	OFF
1	1	ON	ON	OFF	ON
1	1	ON	ON	ON	OFF
1	1	ON	ON	ON	ON

- Left chute (SW5, 6, 7, 8)

Coin	Credit	SW5	SW6	SW7	SW8
1	1	OFF	OFF	OFF	OFF
1	2	OFF	OFF	OFF	ON
1	3	OFF	OFF	ON	OFF
1	4	OFF	OFF	ON	ON
1	5	OFF	ON	OFF	OFF
2	1	OFF	ON	OFF	ON
2	3	OFF	ON	ON	OFF
3	1	OFF	ON	ON	ON
3	2	ON	OFF	OFF	OFF
4	1	ON	OFF	OFF	ON
1	1	ON	OFF	ON	OFF
1	1	ON	OFF	ON	ON
1	1	ON	ON	OFF	OFF
1	1	ON	ON	OFF	ON
1	1	ON	ON	ON	OFF
1	1	ON	ON	ON	ON

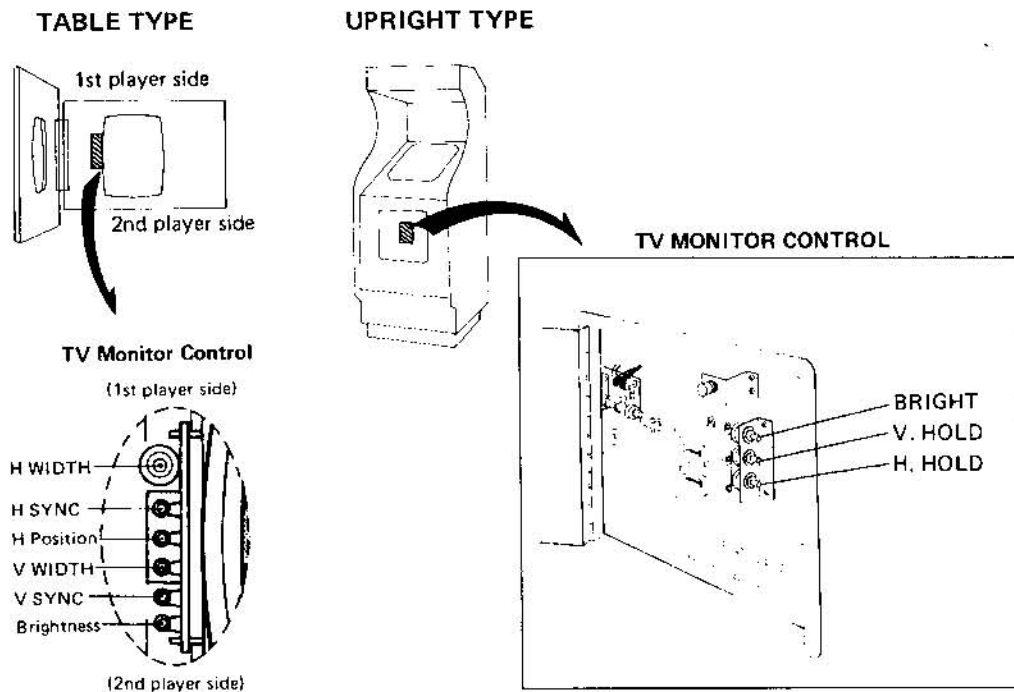
**C. VOLUME CONTROLLER KNOB**



**Fig. 2 Positions of Volume Controller Knob**

**V. TV MONITOR**

**A. ADJUSTMENT OF TV PICTURE SCREEN**



**Fig. 3 Positions of TV Monitor Controller Knobs**



# UPRIGHT TYPE



This documentation provides standard information.  
Universal reserves the right to change without notice.

# VI. UPRIGHT TYPE PARTS CATALOG

## A. COMPONENT PARTS RELATED TO CABINET (OUTSIDE)

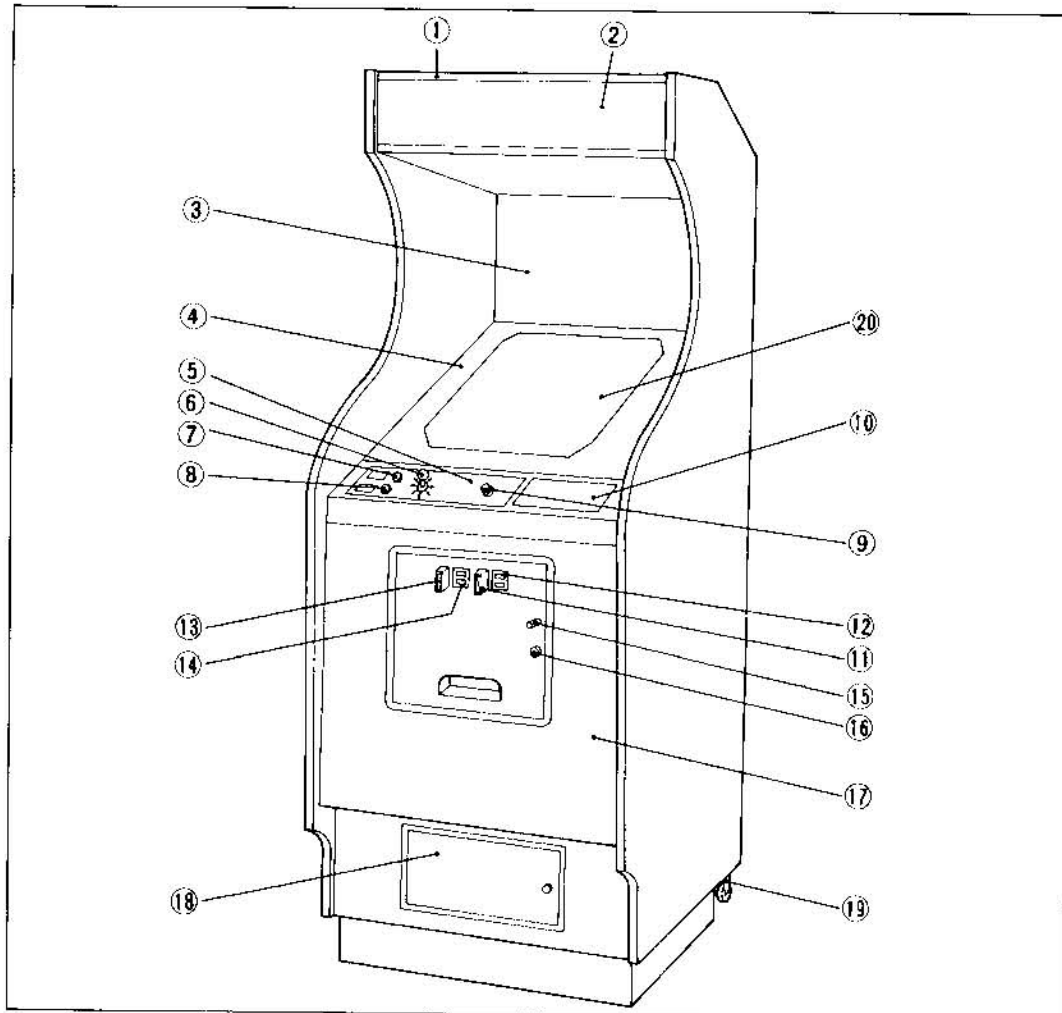
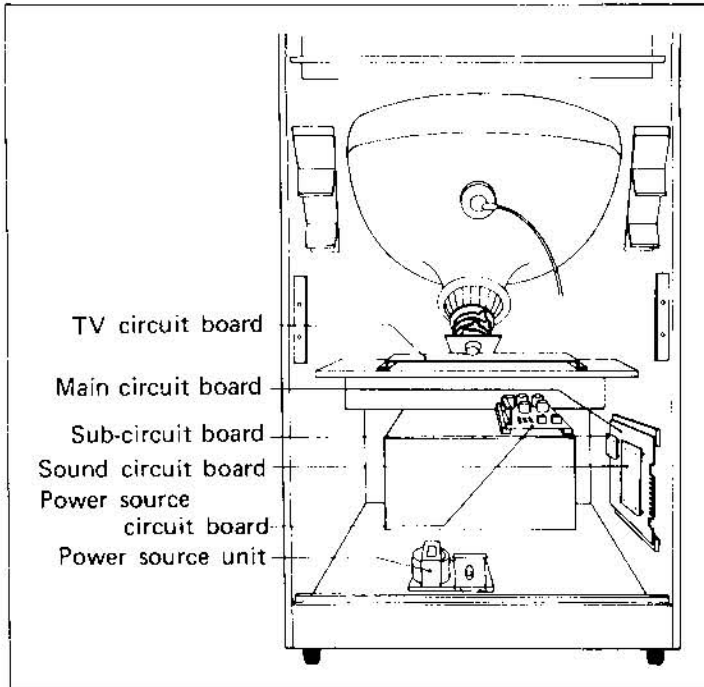


Fig. 4 Component Parts Related to Cabinet (Outside)

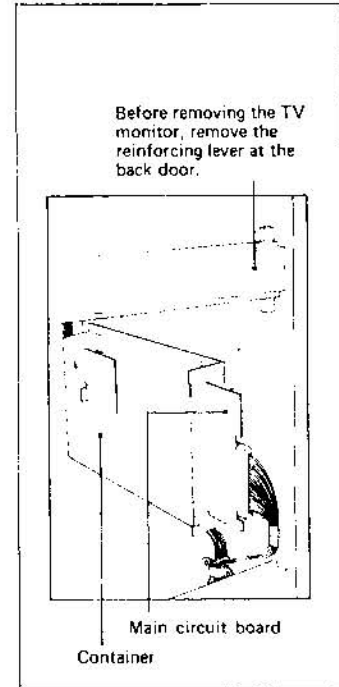
### OUTSIDE CABINET PARTS LIST

Ref. No.	Name	Ref. No.	Name
1	Title panel fixture	11	Coin slot (1)
2	Title panel	12	Coin indication panel (1)
3	Illustrated glass (B)	13	Coin slot (2)
4	Illustrated glass (A)	14	Coin indication panel (2)
5	Operating indication panel	15	Cancel button
6	Control lever (general name)	16	Door key
7	Push button (for 1 player)	17	Main door
8	Push button (for 2 players)	18	Cash box door
9	Push button (Fire)	19	Caster
10	Sticker for game rules	20	CRT (20" color)

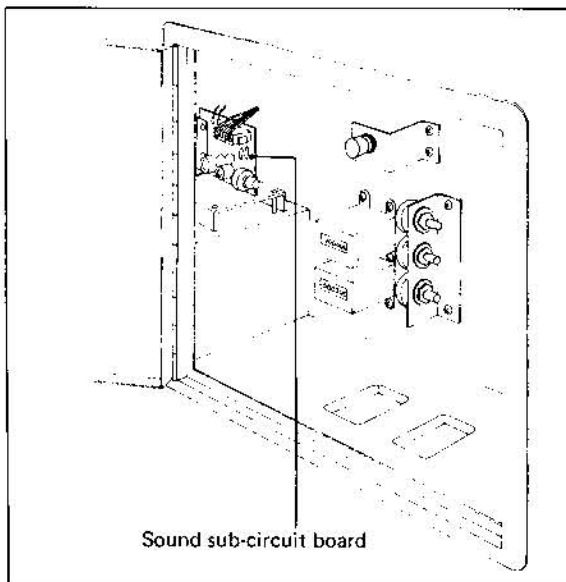
**B. DRAWING OF CIRCUIT BOARD MOUNTING POSITIONS**



**Fig. 5 Circuit Board Mounting Positions**

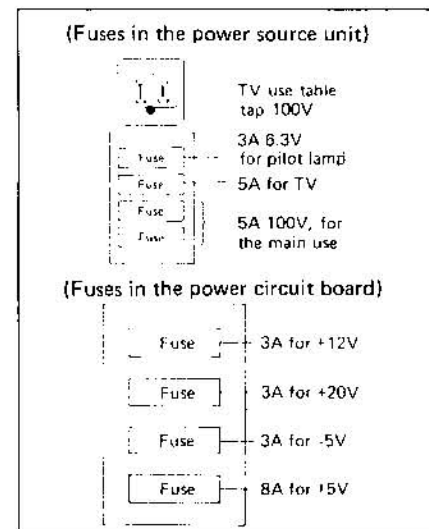


**Fig. 6 Side View of Circuit Board Mounting Positions**



**Fig. 7 Position of Sound Sub-circuit Board**

**C. FUSES**



**Fig. 8 Fuses**

D. COMPONENT PARTS RELATED TO CABINET (INSIDE)

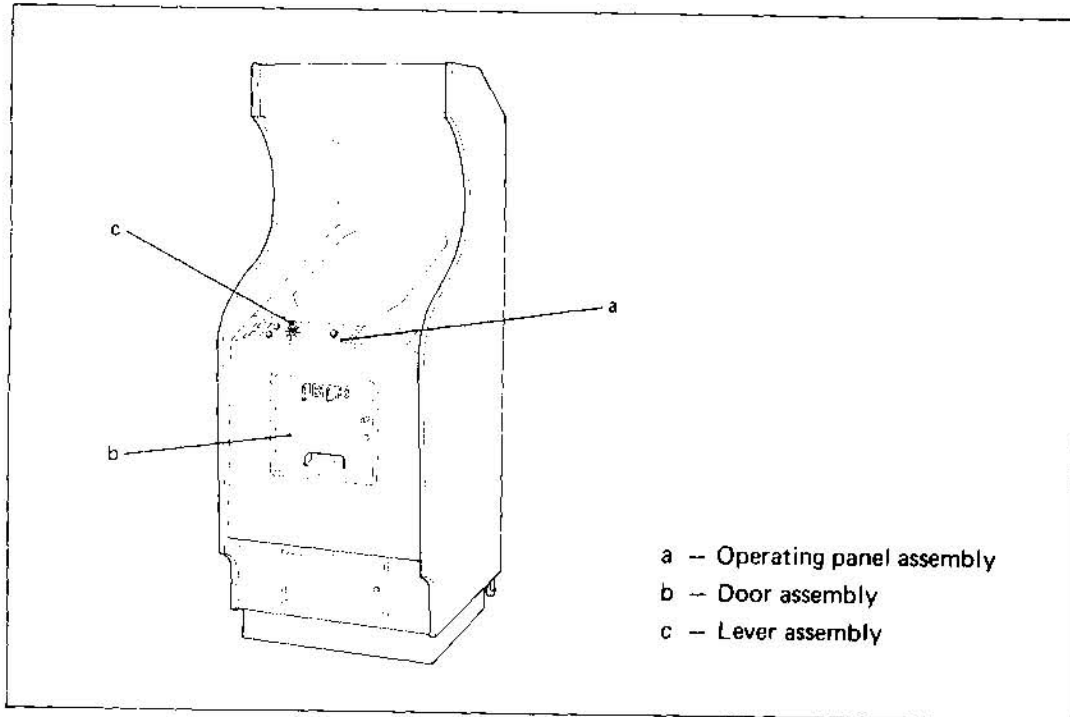


Fig. 9 Component Parts Related to Cabinet (Inside)

a) Operating panel assembly

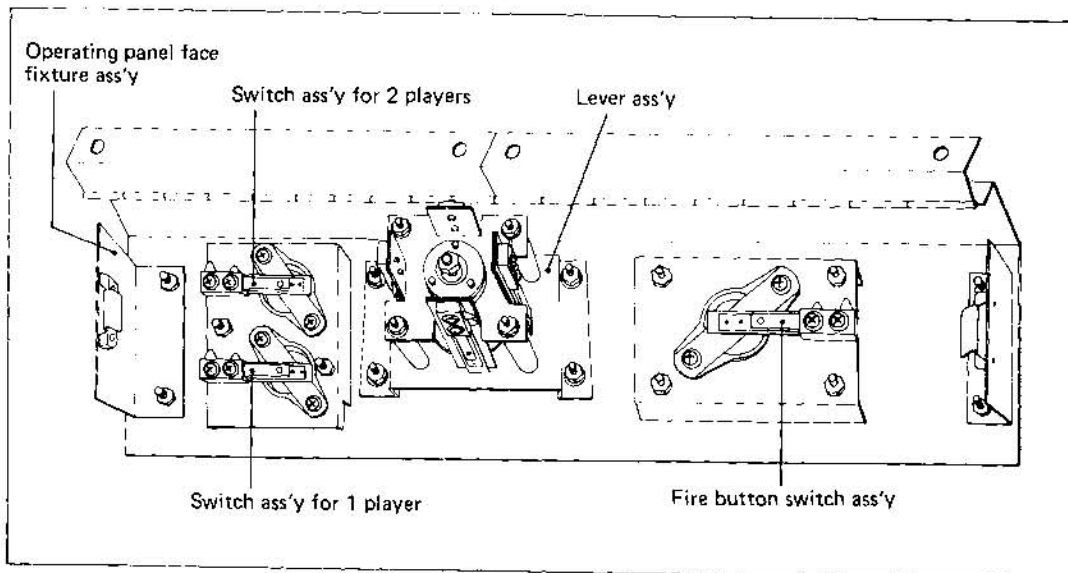
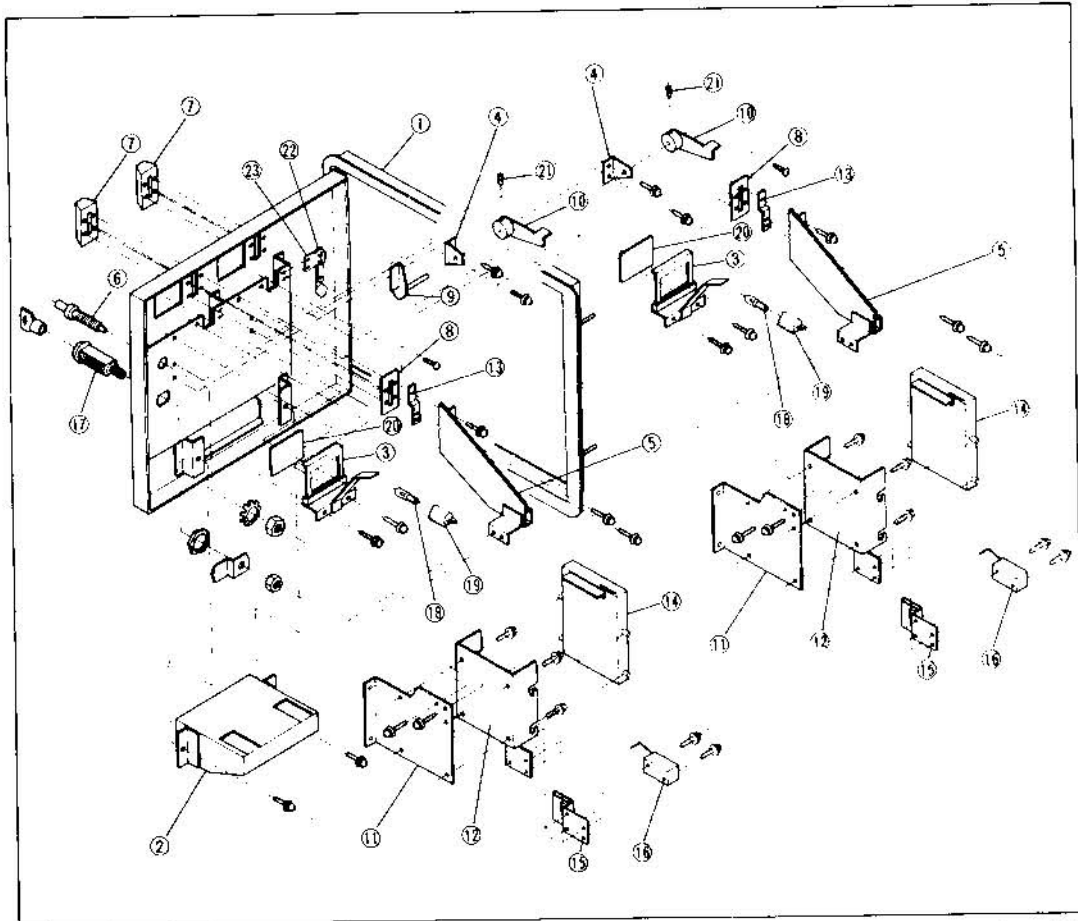


Fig. 10 Operating Panel Assembly

**b) Door assembly and parts list**



**Fig. 11 Inside View of Door Assembly**

**DOOR ASSEMBLY PARTS LIST**

Ref. No.	Name	Ref. No.	Name
1	Main door	13	Coin slot shute holder
2	Returning soucer	14	Rejector
3	Lamp & plastic plate bracket	15	Sensor slot
4	Rearing	16	Micro switch
5	Coin slot shute	17	Key sets
6	Returning button	18	Miniature lamp
7	Coin slot	19	Miniature lamp socket
8	Slot plate	20	Coin indication panel
9	Transmission shaft	21	Hexagon socket head screw
10	Rotary bracket	22	Slam switch
11	Rejector bracket	23	Slam switch holder
12	Rejector case		

c) Lever assembly and parts list

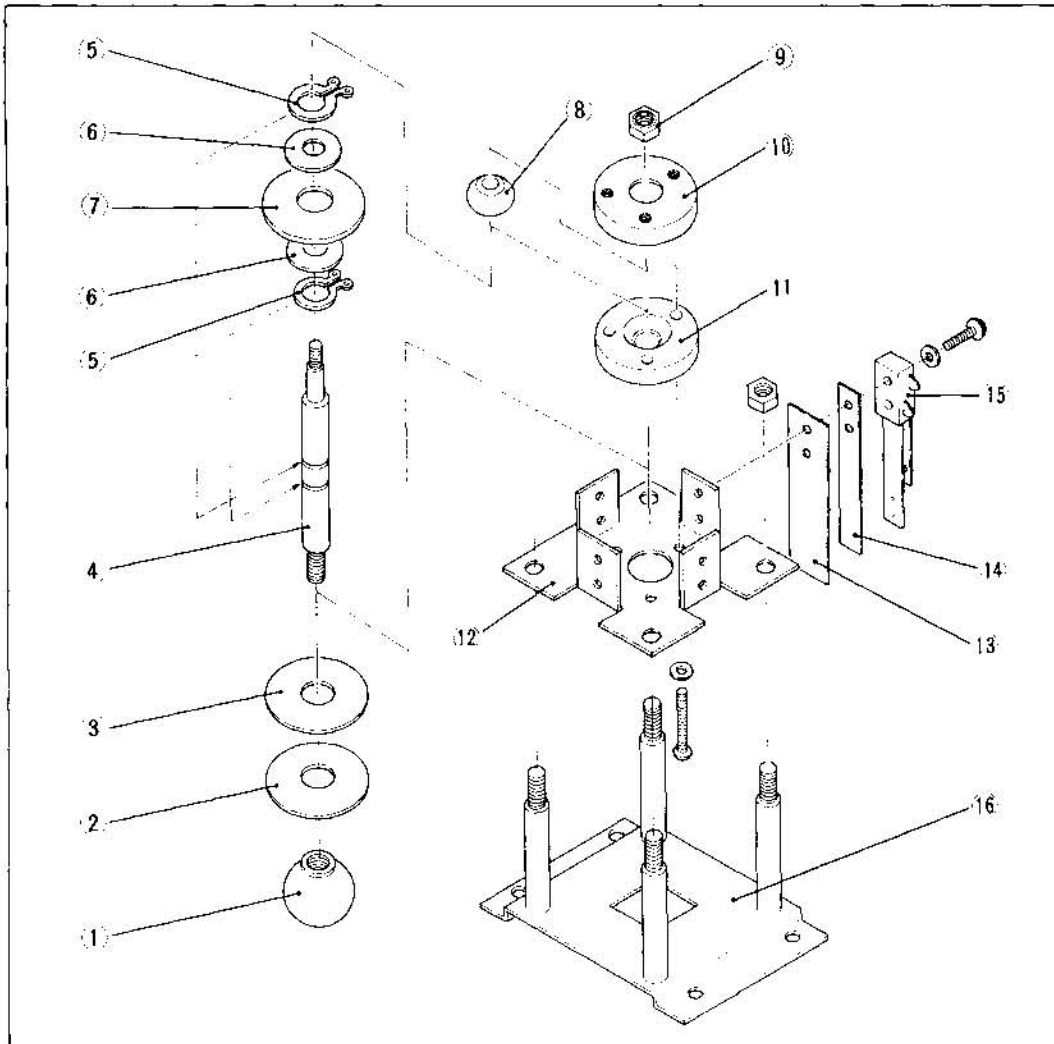
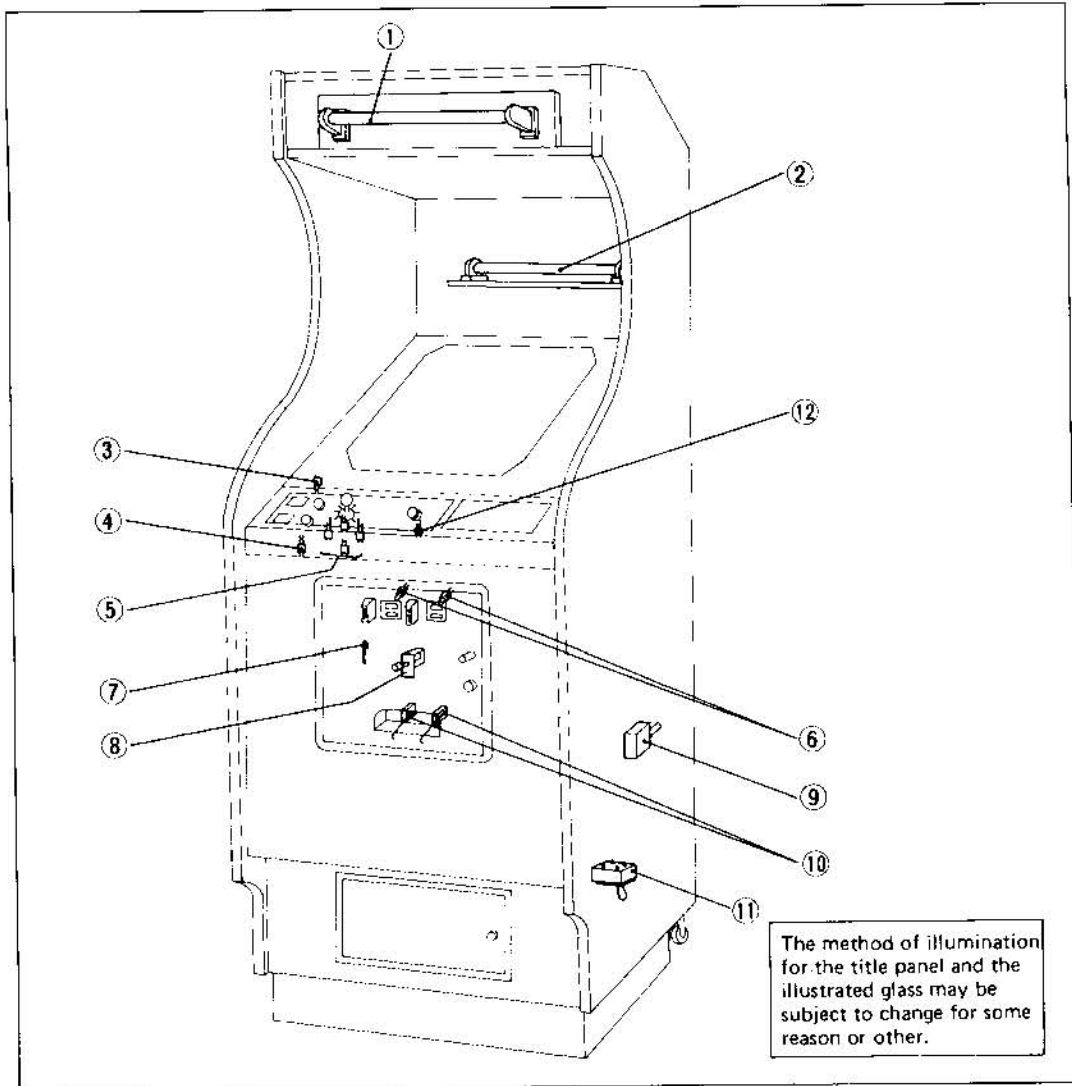


Fig. 12 Lever Assembly

LEVER ASSEMBLY PARTS LIST

Ref. No.	Name	Ref. No.	Name
1	Knob (upright 32Dim., Table 24Dim.)	9	Rock nut
2	Resin board (transparent)	10	Bracket (A)
3	Resin board (Black)	11	Bracket (B)
4	Lever shaft	12	Blades mounting plate
5	Returning rings (C type)	13	Plate spring
6	Flat washer	14	Insulating fiber
7	Detecting disc	15	Blades switch
8	Steel ball	16	Mounting base

**E. COMPONENT PARTS RELATED TO SWITCHES IN THE CABINET**

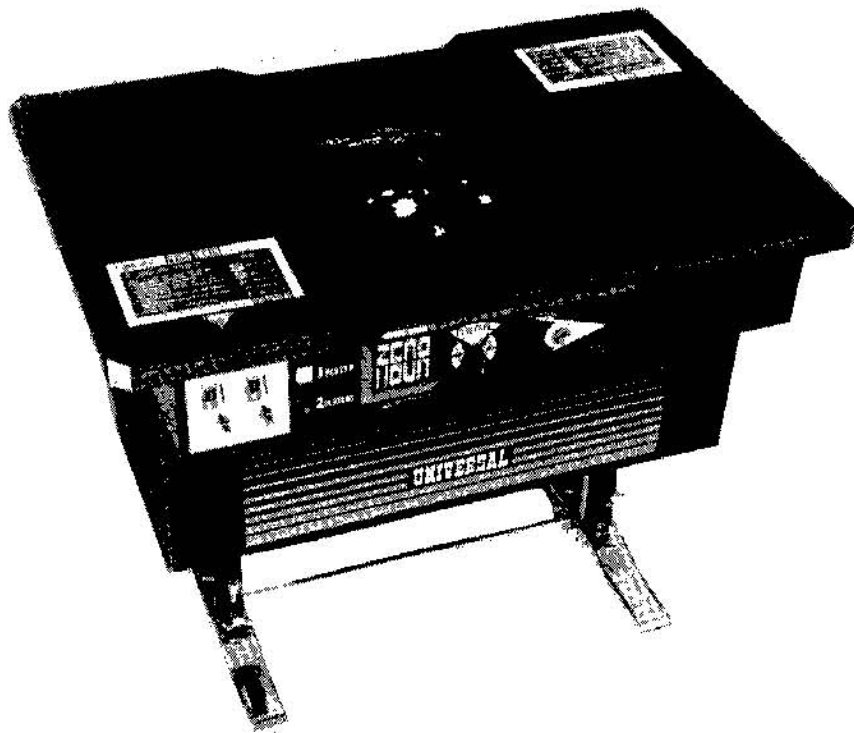


**Fig. 13 Component Parts Related to Switches in the Cabinet**

**INSIDE CABINET PARTS LIST**

Ref. No.	Name	Ref. No.	Name
1	Fluorescent lamp for title panel	7	Blades SW for tilt SW
2	Fluorescent lamp for illustrated glass	8	Micro SW for resetting
3	1-player select button blade SW	9	Door SW
4	2-players select button blade SW	10	Micro SW for rejector x 2
5	Control lever 8-directional use blades SW x 4	11	Toggle SW
6	Miniature lamp for money display x 2	12	Blade SW for Fire

# TABLE TYPE



This documentation provides standard information.  
Universal reserves the right to change without notice.



## VII. TABLE TYPE PARTS CATALOG

### A. COMPONENT PARTS RELATED TO CABINET (OUTSIDE)

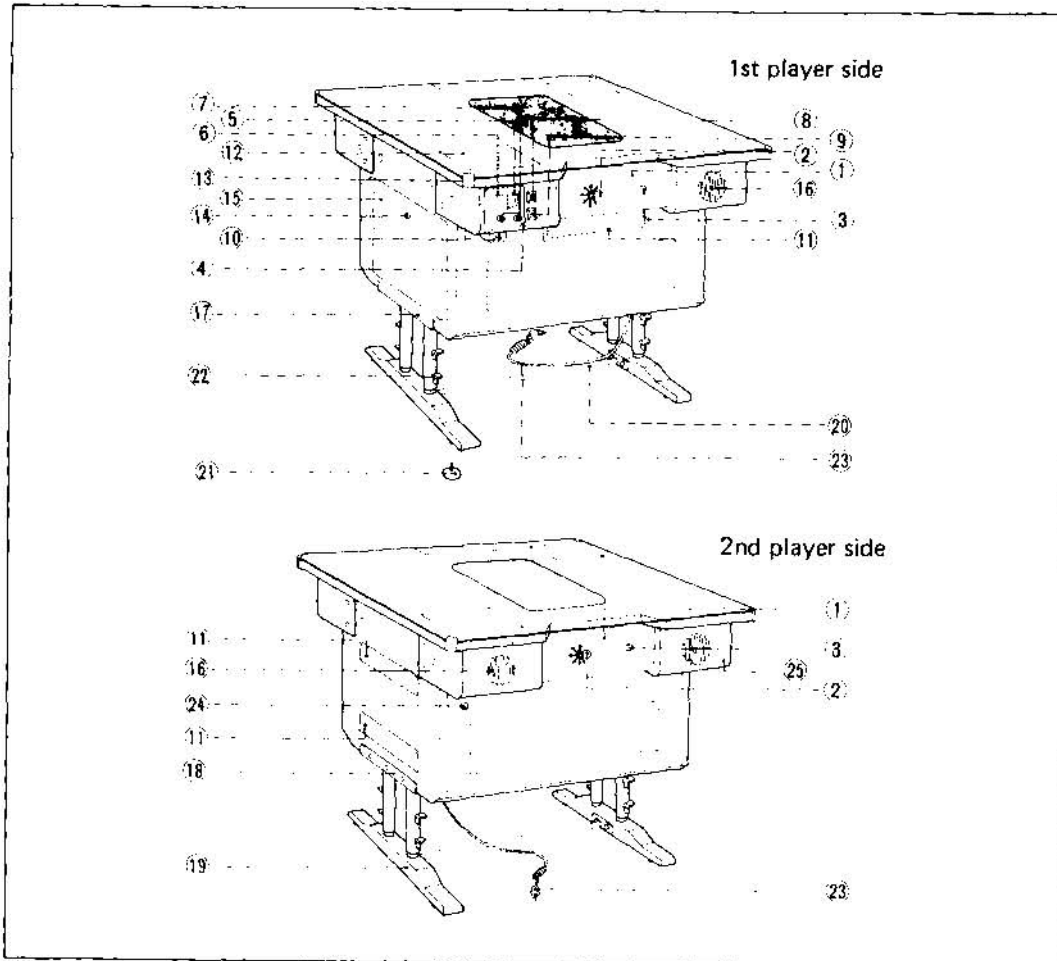


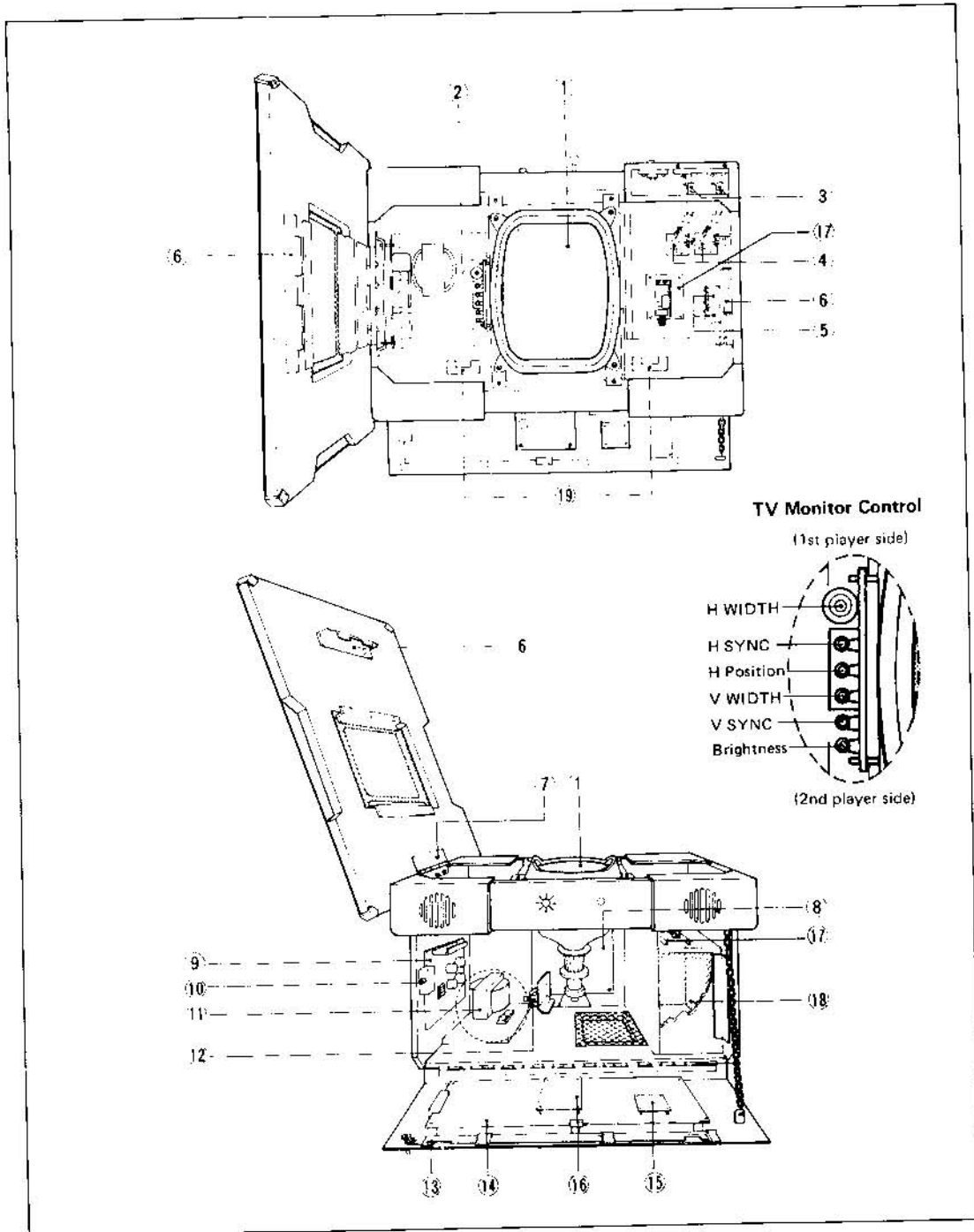
Fig. 14 Component Parts Related to Cabinet (Outside)

#### OUTSIDE CABINET PARTS LIST

Ref. No.	Name	Ref. No.	Name
1	Operating indication illustrated panel	14	Cash box door key
2	Control lever	15	Cash box door
3	FIRE button	16	Speaker (x2)
4	Coin slot frame	17	Leg (left)
5	Selector plate (1)	18	Leg (right)
6	Selector plate (2)	19	Foot
7	Cancel button	20	Foot support
8	Push button ass'y (for 1 player)	21	Leg adjuster
9	Push button ass'y (for 2 players)	22	Thumbscrew (x8)
10	Cancel coin receptacle	23	Power cord (AC)
11	Ventilating panel (x3)	24	Door key
12	Sticker for game rules (x2)	25	Cabinet corner box
13	Glass fittings		

**B. COMPONENT PARTS RELATED TO CABINET (INSIDE)**

**a) Inside cabinet**



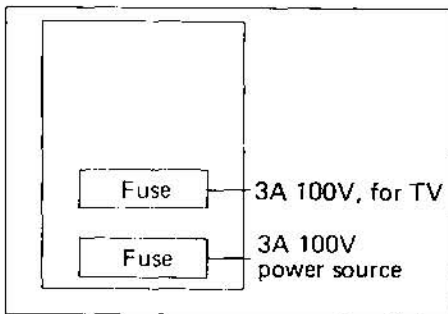
**Fig. 15 Component Parts Related to Cabinet (Inside)**

**INSIDE CABINET PARTS LIST**

Ref. No.	Name	Ref. No.	Name
1	CRT (14" color)	11	Power source unit
2	TV monitor control	12	Demagnetization switch
3	Rejector ass'y	13	Door lock ass'y
4	Coin micro switch	14	Main circuit board
5	Coin counter	15	Sub-circuit board
6	Table lock mechanism ass'y	16	Sound circuit board
7	Butterfly plate ass'y	17	Sound sub-circuit board
8	TV monitor circuit board	18	Cash box
9	Power source circuit board	19	Metal door fixture
10	Door switch		

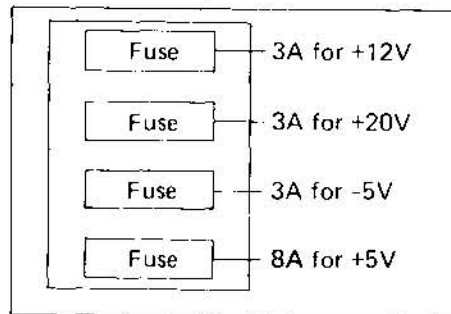
**b) Fuses**

Fuses in the power source unit



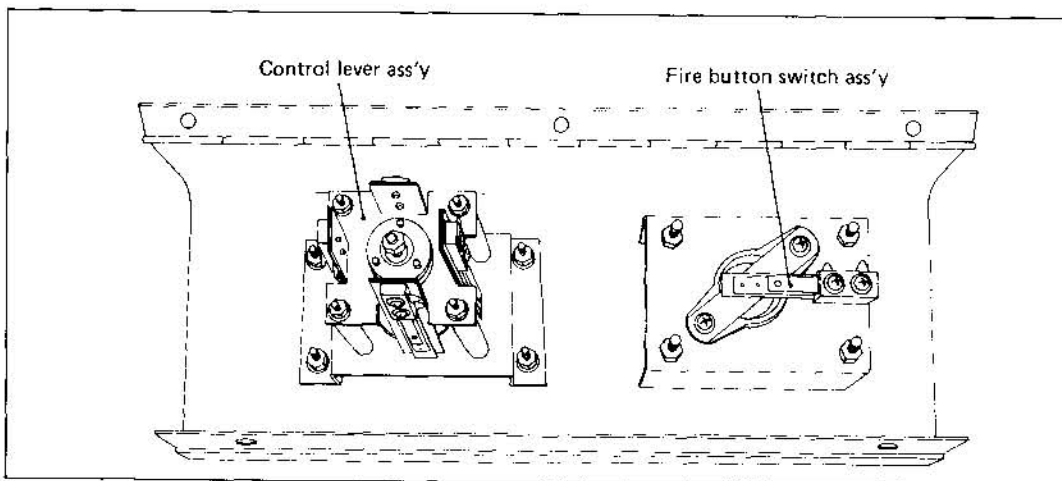
**Fig. 16 Fuses in the Power Source Unit**

Fuses in the power circuit board



**Fig. 17 Fuses in the Power Circuit Board**

**c) Operating panel assembly**



**Fig. 18 Operating Panel Assembly**

# VIII. CIRCUIT BOARD

## A. CIRCUIT BOARD IC LOCATION AND PARTS LIST

### a) Main circuit board IC location and parts list

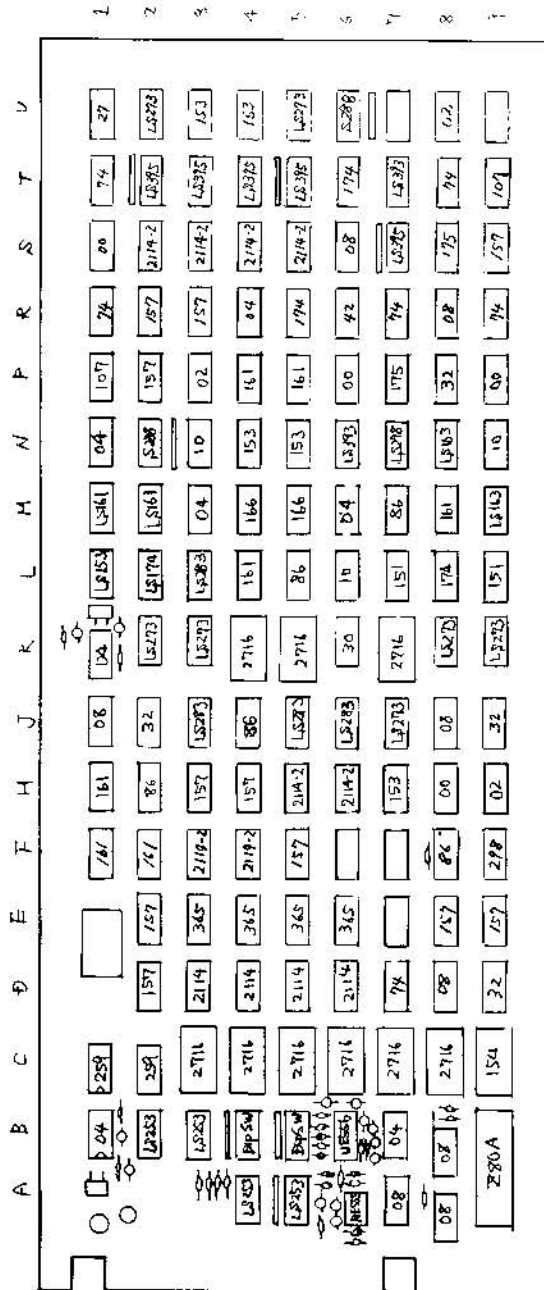


Fig. 19 Main Circuit Board

[1] Integrated Circuit

Item No.	Q'ty	Description
7400N	4	Transistor Logic
7402N	3	"
7404N	7	"
7408N	8	"
7410N	3	"
7427N	1	"
7430N	1	"
7432N	4	"
7442N	1	"
7474N	6	"
7486N	5	"
74107N	2	"
74151N	2	"
74153N	5	"
74154N	1	"
74157N	11	"
74161N	7	"
74166N	2	"
74174N	3	"
74175N	2	"
74259N	2	"
74298N	1	"
74365N	4	"
74LS153N	1	"
74LS161N	2	"
74LS163N	2	"
74LS174N	1	"
74LS253N	4	"
74LS273N	7	"
74LS298N	1	"
74LS393N	2	"
74LS395N	5	"
74S288	2	256 bits Bipolar ROM
Z80A	1	Nch MOS CPU
2716	9	Nch MOS 16K bits EP ROM

Item No.	Q'ty	Description
2114	4	Nch MOS 4K bits Static RAM
2114-2	8	Nch MOS 4K bits Static RAM
NE555	1	Transistor Logic
NE556	1	"

[2] Other Semiconductor Devices

Item No.	Q'ty	Description
1001	6	Diode

[3] Capacitors

Rating	Q'ty	Description
100PF/12V	2	Ceramic Capacitor
0.01µF/12V	5	"
0.1µF/12V	43	"
1µF/50V	2	Chemical Capacitor
4.7µF/16V	1	"
10µF/16V	1	"
100µF/16V	2	"

[4] Resistors

Rating	Q'ty	Description
47Ω 1/4W	4	Carbon Solid Resistors
330Ω "	1	"
510Ω "	4	"
1KΩ "	8	"
4.7KΩ "	1	"
47KΩ "	3	"
MS1028AM	6	1KΩ Resistors Array
MS1038AM	2	10KΩ "

[5] Misc

Name	Q'ty	Description
Dip SW	2	8 Elements Switch Array
X'tal	2	9.828MHz, 4.000MHz

b) Sub-circuit board IC location and parts list

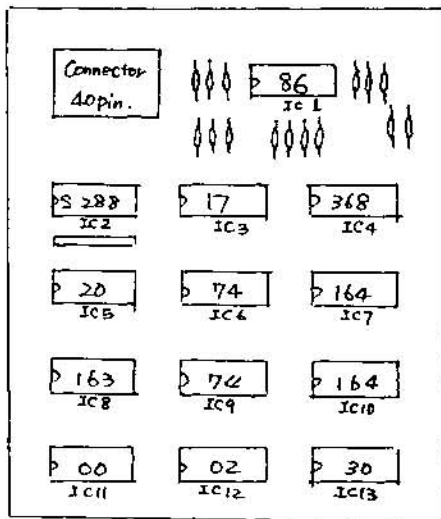


Fig. 20 Sub-circuit Board

[1] Integrated Circuit

Item No.	Q'ty	Description
7400N	1	Transistor Logic
7402N	1	"
7417N	1	"
7420N	1	"
7430N	1	"
7474N	2	"
7486N	1	"
74163N	1	"
74164N	2	"
74365N	1	"
74S288N	1	256 bits Bipolar ROM

[2] Capacitors

Rating	Q'ty	Description
0.1µF/12V	5	Ceramic Capacitor
100PF/12V	1	"

[3] Resistors

Rating	Q'ty	Description
10Ω 1/4W	3	Carbon Solid Resistor
100Ω "	3	"
150Ω "	3	"
220Ω "	3	"
270Ω "	3	"
MS1028AM	1	1KΩ Resistor Array

c) Sound circuit board IC location and parts list

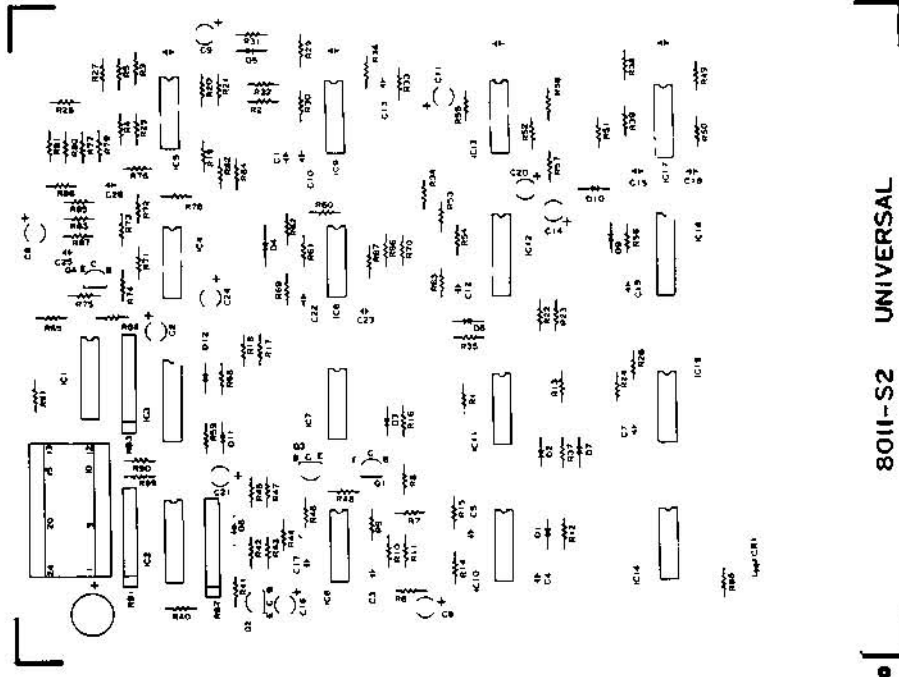


Fig. 21 Sound Circuit Board

Location	Rating	Description
R1	100K	Carbon Solid Resistor
2	100K	"
3	100K	"
4	470K	"
5	470K	"
6	1M	"
7	470K	"
8	51K	"
9	1M	"
10	470K	"
11	1M	"
12	100K	"
13	100K	"
14	100K	"
15	100K	"
16	150K	"
17	51K	"
18	100K	"
19	33K	"
20	10K	"
21	10K	"
22	100K	"
23	100K	"
24	100K	"
25	100K	"
26	200K	"
27	200K	"
28	200K	"
29	1K	"
30	100K	"

Location	Rating	Description
R31	2.2M	Carbon Solid Resistor
32	1K	"
33	10K	"
34	100K	"
35	10K	"
36	100K	"
37	1M	"
38	1K	"
39	100K	"
40	470Ω	"
41	10K	"
42	470K	"
43	1M	"
44	470K	"
45	51K	"
46	470K	"
47	1M	"
48	1M	"
49	1K	"
50	100K	"
51	100K	"
52	100K	"
53	10K	"
54	10K	"
55	10K	"
56	1M	"
57	1M	"
58	1M	"
59	470K	"
60	1K	"

Location	Rating	Description
R61	100K	Carbon Solid Resistor
62	1K	"
63	10K	"
64	33K	"
65	10K	"
66	1K	"
67	100K	"
68	1M	"
69	1K	"
70	10K	"
71	100K	"
72	1K	"
73	100K	"
74	100K	"
75	470Ω	"
76	Not used	"
77	22K	"
78	100K	"
79	51K	"
80	200K	"
81	200K	"
82	100K	"
83	200K	"
84	470K	"
85	200K	"
86	200K	"
87	100K	"
88	330Ω	"
89	10K	"
90	10K	"

Location	Rating	Description
R91	10K	Carbon Solid Resistor
C1	0.01 $\mu$ F	Mila
2	1 $\mu$ F	Chemical
3	220pF	Ceramic
4	1,000pF	Mila
5	1,000pF	"
6	22 $\mu$ F	Chemical
7	0.01 $\mu$ F	Mila
8	1 $\mu$ F	Chemical
9	1 $\mu$ F	"
10	2200pF	Mila
11	1 $\mu$ F	Chemical
12	0.01 $\mu$ F	Mila
13	0.01 $\mu$ F	"
14	1 $\mu$ F	Chemical
15	0.1 $\mu$ F	Ceramic
16	0.47 $\mu$ F	Tantalum
17	220pF	Ceramic
18	3300pF	Mila
19	0.01 $\mu$ F	"
20	1 $\mu$ F	Chemical
21	1 $\mu$ F	"
22	3300pF	Mila
23	3300pF	"
24	1 $\mu$ F	Chemical
25	0.1 $\mu$ F	Ceramic
26	0.1 $\mu$ F	"

Location	Item No.	Description
Q1	25C945	N-P-N Transistor
2	"	"
3	"	"
4	"	"

Location	Item No.	Description
D1	1S1588	Switching Diode
2	"	"
3	"	"
4	"	"
5	"	"
6	"	"
7	"	"
8	"	"
9	"	"
10	"	"
11	"	"
12	"	"

Location	Item No.	Description
RB1	MS1038AM	10K $\Omega$ Resistor Array
2	MS2228AM	2.2K $\Omega$ Resistor Array
3	"	"

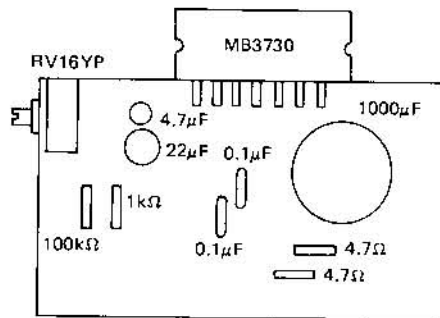
Location	Item No.	Description
CR1	TLR103	Light Energy Diode

Location	Item No.	Description
IC1	ULN2003AN	Darlington Transistor Array
2	ULN2003AN	"
3	CD4049CN	Hex Inverting Buffer
4	LM324N	Quadruple Operational Amplifier
5	LM324N	"
6	LM3900N	"
7	CD4013CN	Dual D Flip Flop
8	NE555N	Dual Timer
9	NE555N	"

Location	Item No.	Description
IC10	CD4070CN	Quad 2-Input E-OR Gate
11	CD4006CN	18-Stage Static Shift Register
12	CD4020N	14-Stage Binary Counters
13	LM324N	Quadruple Operational Amplifiers
14	CD4013CN	Dual D Flip Flop
15	CD4016CN	Quad Bilateral Switch
16	CD4050CN	Hex Non-Inverting Buffer
17	NE555N	Dual Timer

d) Sound Sub-circuit board IC location and parts list



Rating	Q'ty	Description
MB3730	1	Audio Amplifier
1000 $\mu$ F/25V	1	Chemical Capacitor
22 $\mu$ F/25V	1	"
4.7 $\mu$ F/25V	1	"
0.1 $\mu$ F/25V	2	Ceramic Capacitor
1k $\Omega$ 1/4W	1	Carbon Solid Resistor
100k $\Omega$ 1/4W	1	"
4.7 $\Omega$ 1/4W	2	"
RV16YP 1k $\Omega$	1	Carbon Variable Resistor

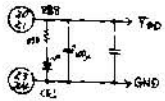
Fig. 22 Sound Sub-circuit Board



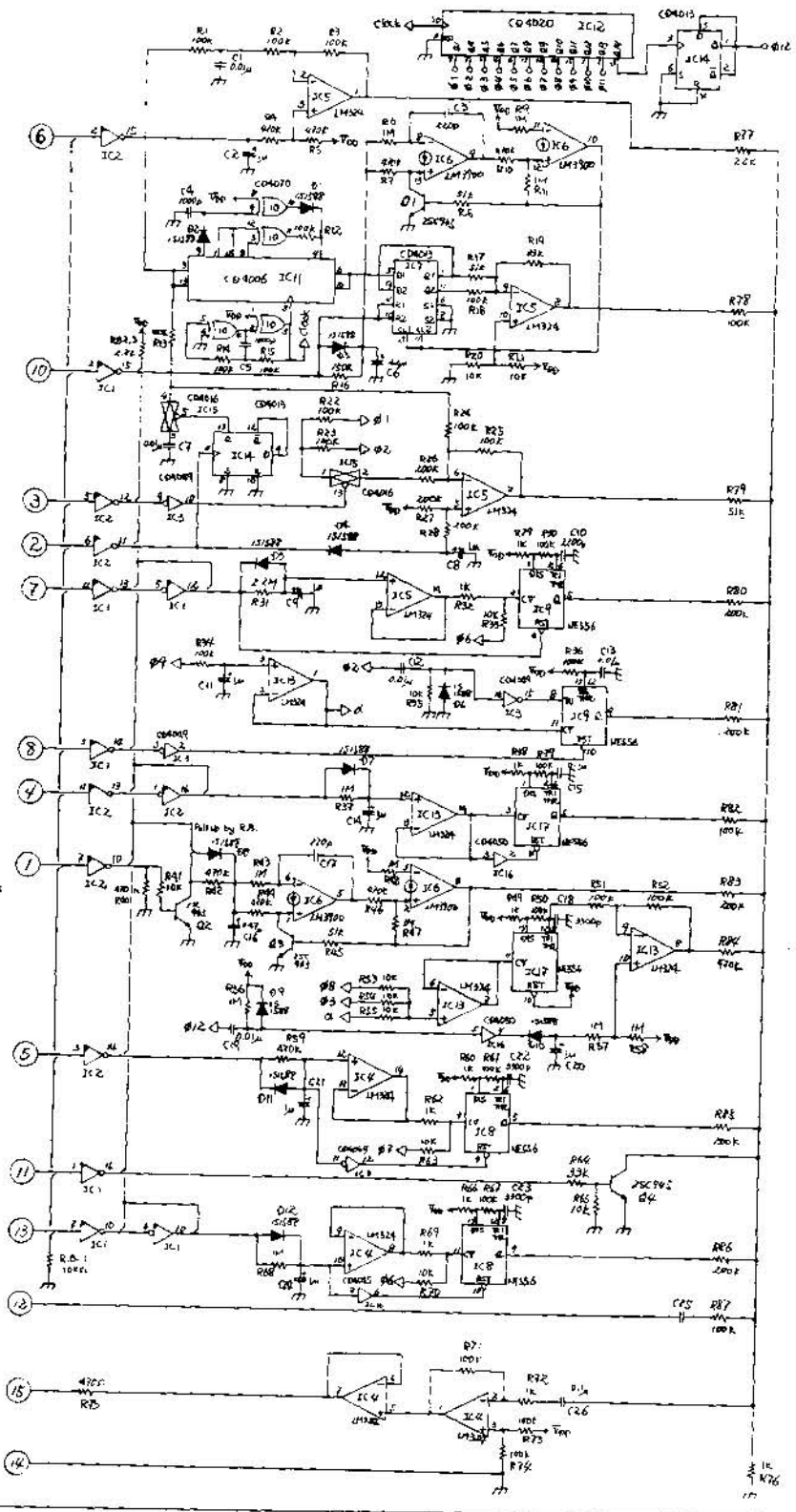


# SOUND BLOCK DIAGRAM

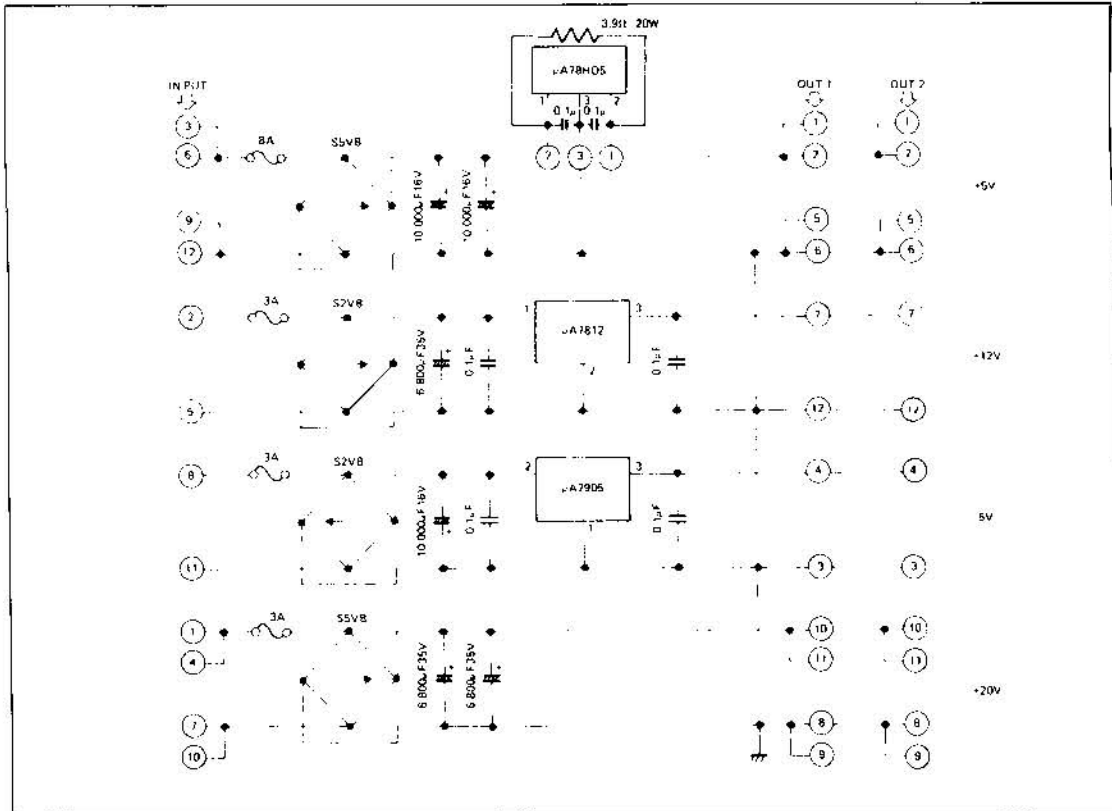
ZERO HOUR  
8011



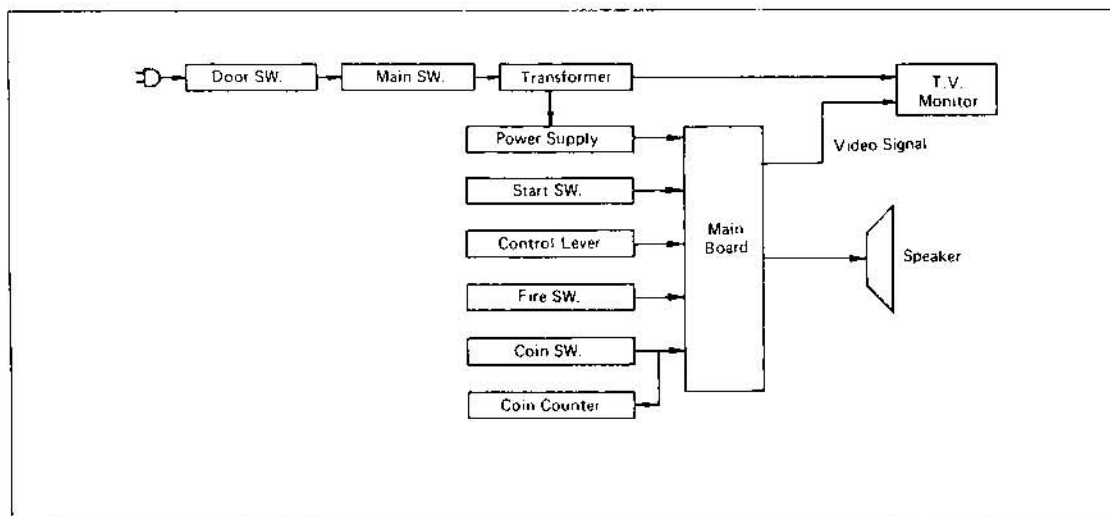
at R89-91 in Input and 4/5 Receivers



POWER SOURCE BLOCK DIAGRAM



BLOCK DIAGRAM

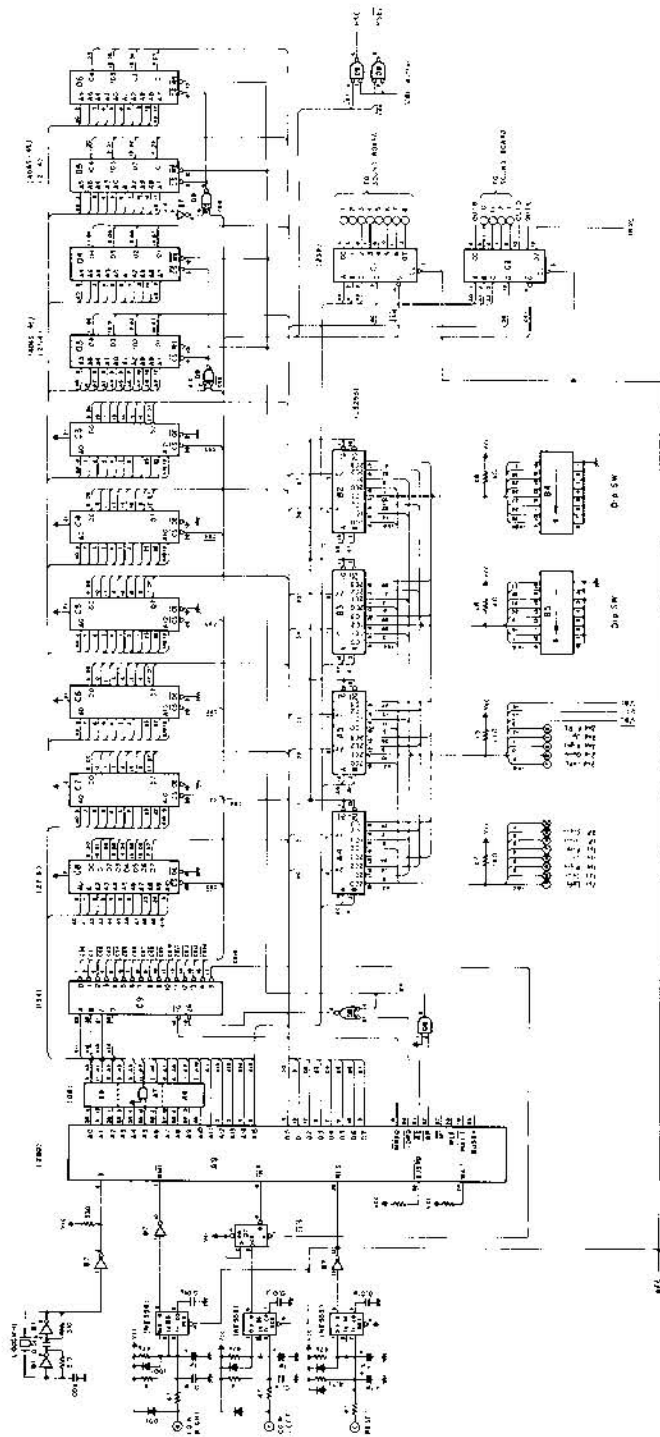


ZERO HOUR

8011

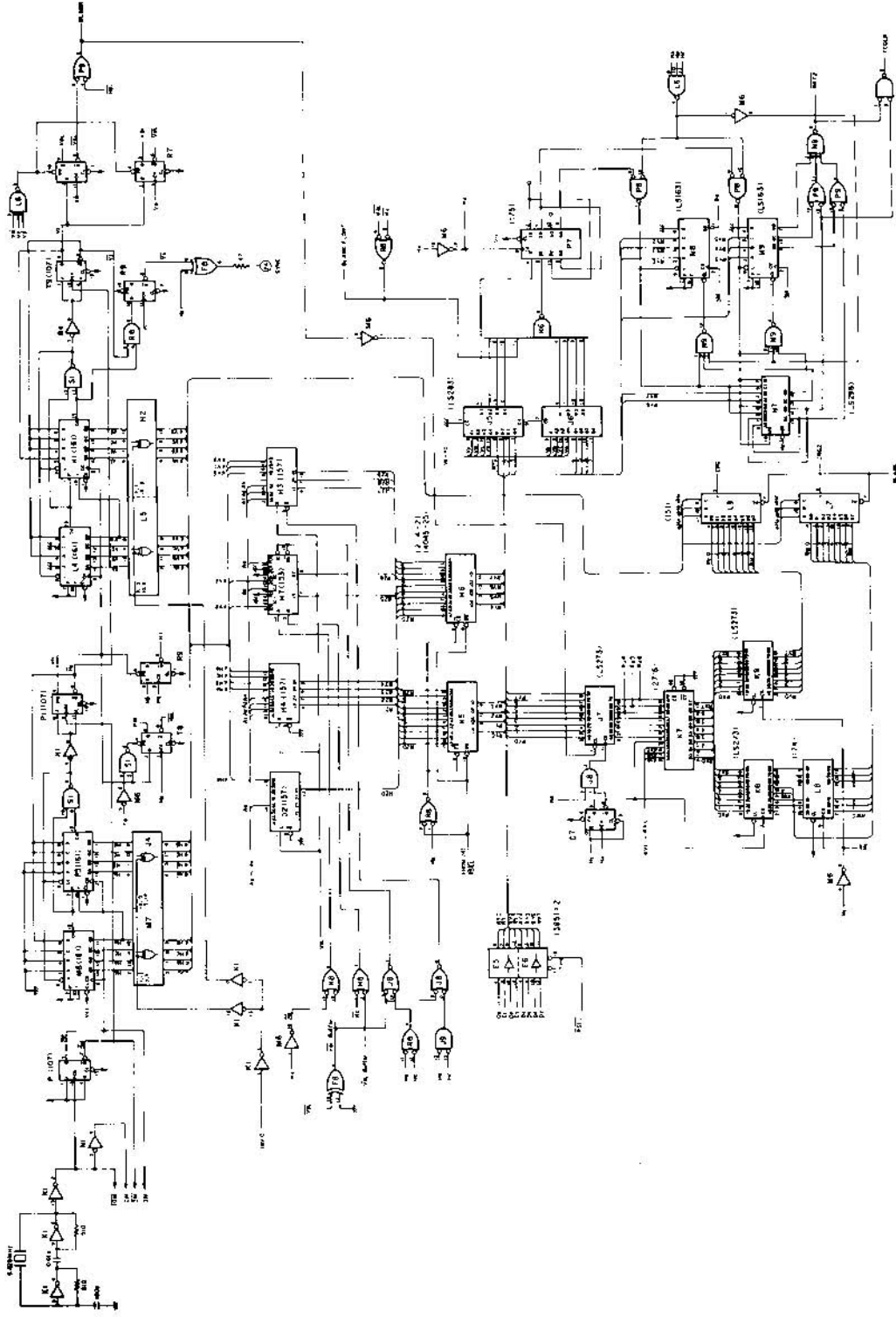
MAIN BLOCK DIAGRAM

No. 1



25V  
Generator

No. 2



ZERO HOUR  
8011

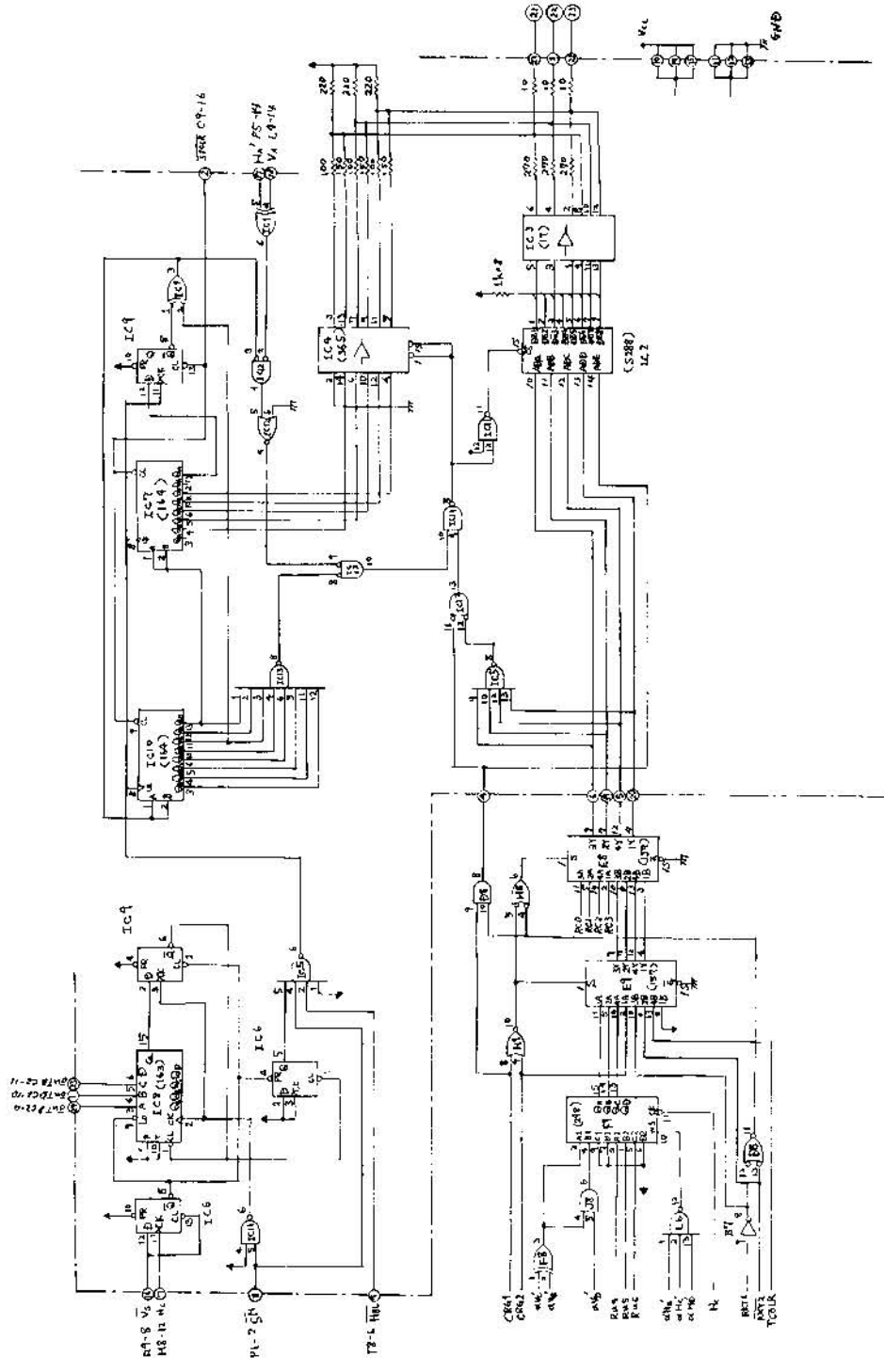
45V  
70 Pin Edge Connector



No. 4

Sub-circuit Board

ZERO HOUR  
8011



5V  
To Edge  
Connector