

# Find-It-In-Front: Dr. Pinball Section

The inside cover & the front 16 pages cover the basics:  
Fuses, Matrixes, Adjustments, Audits and more!

# Section 3 details the Service Menu!

Diagnostics, Audits, Adjustments, Utilities  
(Installs, USB, etc.) and Tournament information!

Find-It-In-Front Dr. Pinball Section	Section 1 After Set-Up	Section 2 Game Op. & Features	Section 3 Service Menu System	Section 4 (Pink) Parts ID. & Location	Section 4 (Blue) Drawings for Major...	Sec. 5 (Yellow) Schematics, Wiring ...	Appendixes A - J Historical Data
---	---------------------------	----------------------------------	----------------------------------	--	---	---	-------------------------------------



Disney's Pirates of the Caribbean © Disney // Music Credits: Yo Ho (A Pirate's Life for Me) Words by Xavier Atencio and Music by George Bruns © 1967 Walt Disney Music Company (ASCAP). Copyright renewed. All Rights Reserved.

## Your Parts Sales & Technical Support Team



**Joe Blackwell**  
DIRECTOR,  
Parts Sales &  
Technical Support



**Patrick Powers**  
Technical Support  
ENGINEER



**Chas Siddiqi**  
Technical Support  
ENGINEER



**Dorothy Brown**  
Parts Sales  
SUPERVISOR



**J. Alfer**  
Technical Support  
Documentation  
ADMINISTRATOR

## Pinball Service Game Manual

Please call, eMail or visit us online for technical support, questions or comments regarding this pinball game.

Go to [www.sternpinball.com](http://www.sternpinball.com) and click Tech. Support & Parts Sales



Once there, you will find Service Bulletins, GAME Code, Parts, Appendixes, Coin Cards, helpful information and much more!

• Toll-Free: 1-800-KICKERS (542-5377) or 1-708-345-7700 • eMail: [parts.service@sternpinball.com](mailto:parts.service@sternpinball.com) •

Stern® Pinball, Inc.  
All Rights Reserved.  
Printed in the U.S.A.  
August 2006

SPI Part Number  
**780-5092-00**

# HOW TO UPDATE YOUR GAME CODE FOR THE NEW S.A.M. SYSTEM

**USB Compatible Memory Stick** (aka Thumb, Flash or Jump Drives) required to copy game code into system.  
 S.A.M. System compatible, tested & SPI approved USB Memory Sticks 128MB+ available through your local distributor: Ask for **SPI Part Number 970-0128-00**

\* to get the Memory Stick with the latest **Game Code** copied to it, add "**the game title name**" to above part number.

STYLE, COLOR, SIZE AND MANUFACTURER SUBJECT TO CHANGE.

Game Code is subject to change. Update this game with the latest code downloaded from our website, from another game or order through your local distributor (use SPI PN + name above).

Upon power-up the display will describe the version of code installed in your game. When directed to do so (via Service Bulletin or website announcement) you will need to update your code ... with the **BOOT FLASH EPROM\*** installed, **here's how:**



● **Green Button**  
 Press to **Escape Back** (or **Exit**).

●● **Red Buttons**  
 Press to move **< Left , Right >**.  
 Press to **- Decrease** or **+ Increase** values or to change settings.

● **Black Button**  
 Press to **Enter Select** (or **'OK'**).

- STEP 1** Open the Back Box and locate the **8-Position Dip Switch (SW1 on the CPU/Sound Board)**.
- STEP 2** Switch Dip Switch #8 to 'ON'.  
 (\***BOOT FLASH EPROM** must be installed.)
- STEP 3** Press the **White Reset Button (S1 RESET on the CPU/Sound Board)** or Power Cycle the game **OFF/ON** (ON/OFF Switch is located on the outside of the cabinet bottom, front right).
- STEP 4** Using the **4-Button Service Switch Set** (inside the Coin Door):
  - 4A }** Press [**SELECT**] to begin.
  - 4B }** With the "UPDT" *Icon highlighted*, press [**SELECT**].
  - 4C }** Insert the Memory Stick [with latest file(s)] into the USB Port.
  - 4D }** If more than one file is present on the Memory Stick, press [**<**] or [**>**] to locate your file. Press [**SELECT**] to update.
  - 4E }** Follow on-screen prompts.

## CPU/Sound Board (S.A.M. System)

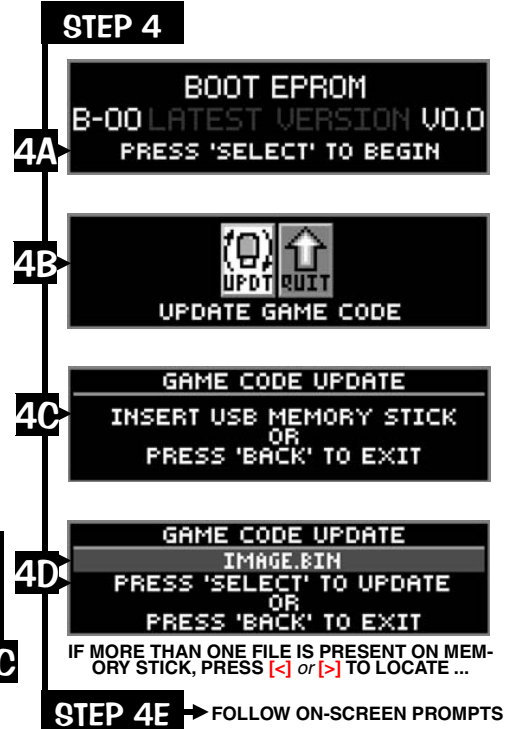
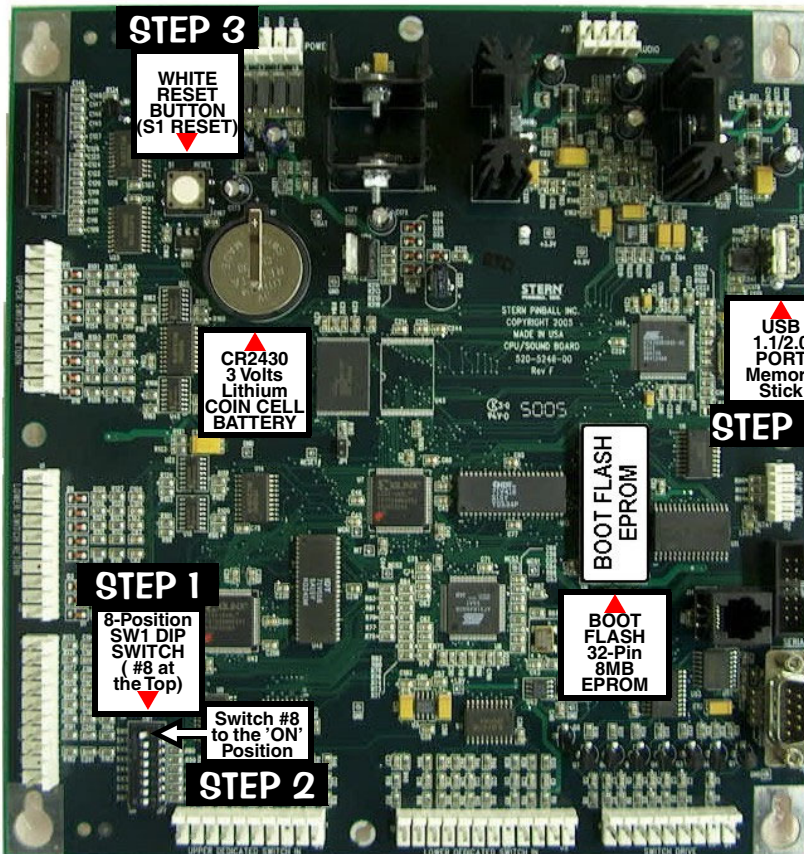

You can also retrieve your latest code from another game! From the **USB MENU** via the **UTILITIES MENU**, select the "BKUP" *Icon* instead and download to your Memory Stick. Review the end of Section 3, Chapter 5.



**! Quick Tip ~ Try backing up your current code prior to installing your new code, just in case your Memory Stick file was corrupted by a computer glitch while you were copying / downloading.**

Got confused? Comments? Questions? Call Technical Support at 800-542-5377 or 708-345-7700 (Option 1).

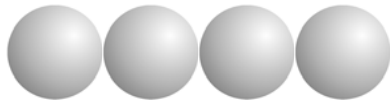

For Proper Operation of this Pinball Game, (4)  
Pinballs must be installed in the Ball Trough!



## Backbox Fuses\*, Cabinet Fuses, Playfield Fuses and Cabinet Switches

QUICK REFERENCE FUSE CHART	
3/4A S.B. 200-5000-17   3A S.B. 200-5000-08   4A S.B. 200-5000-06   5A S.B. 200-5000-01   7A S.B. 200-5000-03   8A S.B. 200-5000-05	
<b>BACKBOX FUSES</b>	
I/O POWER DRIVER BOARD	
<i>with RED LED STATUS INDICATORS (if any RED LED is OFF, check the fuse)</i>	
F1	5A S.B. 5.7VAC G.I. Lamps [BROWN-WHITE↔WHT-BRN]
F2	5A S.B. 5.7VAC G.I. Lamps [YELLOW↔WHITE-YEL Circuit]
F3	5A S.B. 5.7VAC G.I. Lamps [GREEN↔WHITE-GRN Circuit]
F4	5A S.B. 5.7VAC G.I. Lamps [VIOLET↔WHITE-VIO Circuit]
F5	7A S.B. 50VDC Coils / Flippers [48VAC feed to BRDG 1]
F6	3A S.B. 24vac Motor or Special Application
F7	4A S.B. 50VDC Magnet(s) or Special Application
F8	3A S.B. 50VDC Coils
F9	8A S.B. 18VDC Control Lamps [13VAC feed to BRDG 4]
F10	5A S.B. 20VDC Coils / Flashers [16VAC feed to BRDG 2]
F11	4A S.B. 5VDC Logic Power [8VAC feed to BRDG 5]
F12	5A S.B. 12VDC Audio [19VAC feed to BRDG 3]
F13	5A S.B. 12VDC Audio [19VAC feed to BRDG 3]
<b>DISPLAY POWER SUPPLY BOARD</b>	
F1	3/4A S.B. 90VDC High Voltage Dot Display Board
<b>CABINET FUSES</b>	
POWER (SERVICE OUTLET) BOX	
<i>(Access through Coin Door inside cabinet, front bottom.)</i>	
8A S.B.	110-120V Main Line US / Canada / Japan
5A S.B.	220-240V Main Line International
<b>PLAYFIELD FUSES</b>	
FLIPPER OR SPECIAL APPLICATION	
<i>(Coil Fuses are located under the playfield near assembly.)</i>	
3A S.B.	50VDC R. Flipper [BLU-YEL↔RED-YEL]
3A S.B.	50VDC L. Flipper [GRY-YEL↔RED-YEL]
3A S.B.	50VDC Additional Flipper Coil, if used.
3A S.B.	50VDC Spcl. Application Coil, if used.
<i>For location &amp; more details on fuses, see Sec. 5, Chp. 2.</i>	
<p>ALL FUSES ARE 250V S.B. (SLO-BLO) SEE FUSE OR TABLES FOR AMP RATING CAUTION: FOR CONTINUED PROTECTION AGAINST RISK OF FIRE, REPLACE ONLY WITH SAME TYPE FUSE WITH IDENTICAL ELECTRICAL RATING!</p>	
Stern Pinball®, Inc. ©2006 820-6384-00 Rev. A	

\*CPU/Sound Board does not have fuses.

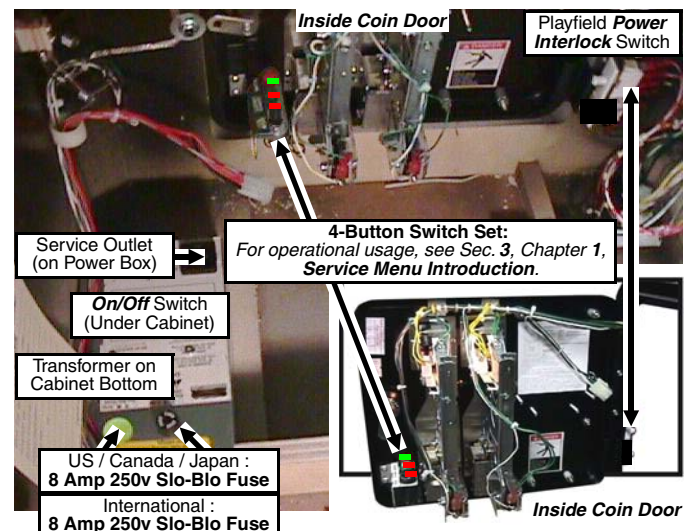

Find-It-In-Front:  
Dr. Pinball



# ////// FIND-IT-IN-FRONT: Dr. Pinball Section Explained ////

The key technical data from various parts of the manual were extracted and combined into the "Find- It-In-Front: Dr. Pinball Section." This front section ( Pages DR. 1 - 16) will assist the technician in locating important technical information needed to troubleshoot the Pinball Machine. To enter the **SERVICE MENU**, read below.

## ● ● ● ● Service Switch X4 Set Overview

The four buttons (inside Coin Door) have dual functions depending if you have entered the **Service Menu** or not.

### Functions in Game or Attract Mode

- **Green Button**  
Press for **Service Credit(s)**.
- **Red Buttons**  
Press for **Volume Adjustment** - for less (quieter), + for more (louder)
- **Black Button**  
Press for **Service Menu entry**.

### Functions in the Service Menu

- **Green Button**  
Press to **Escape Back** (or **Exit**).
- **Red Buttons**  
Press to move **< Left , Right >**. Press to - **Decrease** or + **Increase** values or to change settings.
- **Black Button**  
Press to **Enter Select** (or **'OK'**).

## OPEN THE COIN DOOR TO ACCESS THE SERVICE SWITCH X4 SET.

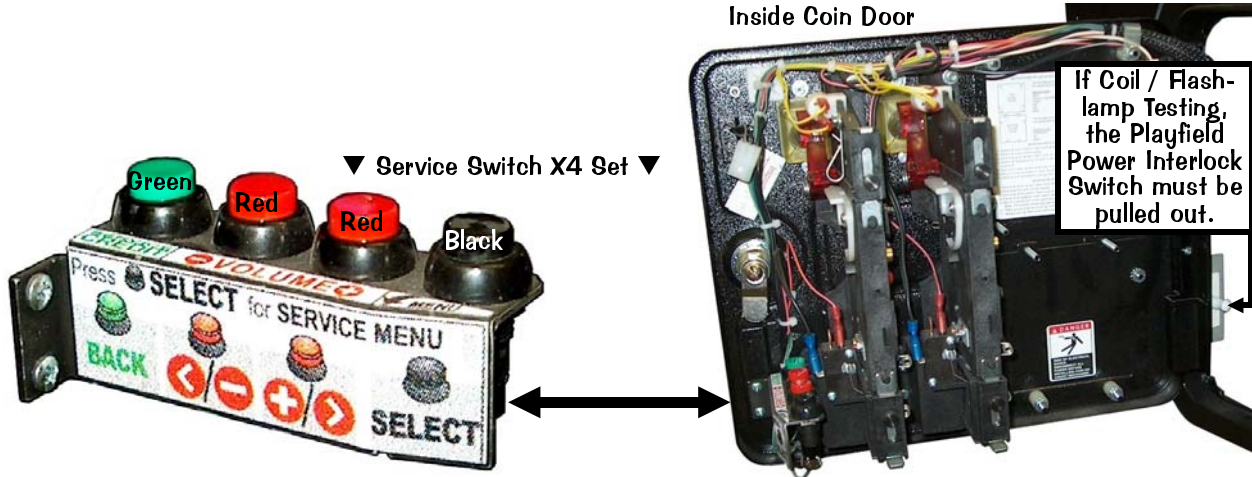

### EXAMPLE:

To enter the **SERVICE MENU**, then enter the **SWITCH TEST MENU** via the **DIAGNOSTIC MENU**, perform the below steps.

**Step 1** Press [ **SELECT** ].

**Step 2** With the "DIAG" Icon highlighted, press [ **SELECT** ].

**Step 3** With the "SW" Icon highlighted, press [ **SELECT** ].

**Step 4** With the "TEST" Icon highlighted, press [ **SELECT** ].

Press any switch. If wired correctly, the information in the display will match the information in the Switch Matrix (see DR. 4).

Press [ **<** ] or [ **>** ] to move left or right through the menus.

Press [ **BACK** ] to go back a menu, exit or escape at any time.

Continue through the other menus.

More details & information about the **SERVICE MENU** is covered in Section 3. *The Service Menu is subject to change. Update this game with the latest code downloaded from our website with a USB Memory Stick (64MB min., recommendation 128MB or higher). See the inside front cover for directions or in the Service Menu "Go To Utilities"*



# DIAGNOSTIC AIDS

**50V / 20V DISABLED**  
 CLOSE COIN DOOR  
 OR PULL INTERLOCK SWITCH  
 TO RESTORE POWER

This **audible / visual alert display** is shown when the **50V / 20V Power** is disabled (by opening the Coin Door). **PULL OUT THE INTERLOCK SWITCH ONLY WHILE IN THE SERVICE MENU FOR COIL, SWITCH OR PLAY TESTING WHEN THE COIN DOOR IS REQUIRED TO STAY OPEN FOR SERVICE BUTTON USE!** Pulling out the Power Interlock Switch or pressing the

'escape' **Green [ BACK ] Button** will remove the alert display. Initial display presentation is accompanied by 3 audible tones (the bright display warning will go dim after approximately 30 seconds).

**OPERATOR ALERT!**  
 AUTO PLUNGER  
 DEVICE MALFUNCTION

This **alert display** is shown momentarily during **Game Mode** or **Power-Up** to alert the operator of a device malfunction (device or mechanism doesn't energize or is energized repeatedly).

**OPERATOR ALERT!** works by monitoring any switch activated device that has the potential to trap a ball when disabled (e.g. in the Shooter Lane, Scoop or Eject Holes, etc.). This alert can also appear if a switch associated with a device (e.g. Ball Trough, Auto Plunger, etc.) is stuck closed (caused by a switch jam or stuck ball); the game will activate the device a predetermined number of times and if the problem is still detected, this device or switch will be noted in **Switch Alerts** (Page 14) and/or **Technician Alerts** (Page 18).

V0.00    GAME NAME    HDW. 0  
 SYS. 0.00  
**SERVICE MENU \***  
 USE -/+ TO VIEW TECH. ALERTS

Upon entering the **SERVICE MENU**, if an asterisk " \* " is displayed after the words "SERVICE MENU," the game has detected possible faulty devices, switches and/or missing pinballs. Press the either of the **Red Buttons** (short-cut to the **TECHNICIAN ALERTS MENU**) or continue into the **SERVICE MENU** (press the **Black Button** again), select the "DIAG" Icon and "TECH" Icon for the **Technician Alerts** information (Page 18).

## CPU DIP SWITCH SETTINGS

The 8-Pos. Dip Switch [SW1] is on the CPU/Sound Board (between Conn. J3 & J13, lower left corner)

CPU COUNTRY SETTING:	Pos:	1	2	3	4	5	6	7	8
<b>USA</b>	ON								
	OFF	▼	▼	▼	▼	▼	▼	▼	▼

CPU COUNTRY SETTING:	Pos:	1	2	3	4	5	6	7	8
<b>France</b>	ON	▲	▲						
	OFF	▼	▼	▼	▼	▼	▼	▼	▼

CPU COUNTRY SETTING:	Pos:	1	2	3	4	5	6	7	8
<b>Portugal</b>	ON	▲			▲				
	OFF	▼	▼	▼	▼	▼	▼	▼	▼

CPU COUNTRY SETTING:	Pos:	1	2	3	4	5	6	7	8
<b>Austria</b>	ON	▲							
	OFF	▼	▼	▼	▼	▼	▼	▼	▼

CPU COUNTRY SETTING:	Pos:	1	2	3	4	5	6	7	8
<b>Germany</b>	ON	▲	▲	▲					
	OFF	▼	▼	▼	▼	▼	▼	▼	▼

CPU COUNTRY SETTING:	Pos:	1	2	3	4	5	6	7	8
<b>Russia</b>	ON	▲		▲	▲				
	OFF	▼	▼	▼	▼	▼	▼	▼	▼

CPU COUNTRY SETTING:	Pos:	1	2	3	4	5	6	7	8
<b>Australia</b>	ON	▲		▲	▲				
	OFF	▼	▼	▼	▼	▼	▼	▼	▼

CPU COUNTRY SETTING:	Pos:	1	2	3	4	5	6	7	8
<b>Greece</b>	ON	▲	▲	▲	▲				
	OFF	▼	▼	▼	▼	▼	▼	▼	▼

CPU COUNTRY SETTING:	Pos:	1	2	3	4	5	6	7	8
<b>So. Africa</b>	ON			▲		▲			
	OFF	▼	▼	▼	▼	▼	▼	▼	▼

CPU COUNTRY SETTING:	Pos:	1	2	3	4	5	6	7	8
<b>Belgium</b>	ON	▲	▼						
	OFF	▼	▼	▼	▼	▼	▼	▼	▼

CPU COUNTRY SETTING:	Pos:	1	2	3	4	5	6	7	8
<b>Italy</b>	ON				▲				
	OFF	▼	▼	▼	▼	▼	▼	▼	▼

CPU COUNTRY SETTING:	Pos:	1	2	3	4	5	6	7	8
<b>Spain</b>	ON	▲	▼		▲				
	OFF	▼	▼	▼	▼	▼	▼	▼	▼

CPU COUNTRY SETTING:	Pos:	1	2	3	4	5	6	7	8
<b>Canada 1</b>	ON	▲	▲						
	OFF	▼	▼	▼	▼	▼	▼	▼	▼

CPU COUNTRY SETTING:	Pos:	1	2	3	4	5	6	7	8
<b>Japan</b>	ON	▲		▲	▲				
	OFF	▼	▼	▼	▼	▼	▼	▼	▼

CPU COUNTRY SETTING:	Pos:	1	2	3	4	5	6	7	8
<b>Sweden</b>	ON	▲	▲	▲					
	OFF	▼	▼	▼	▼	▼	▼	▼	▼

CPU COUNTRY SETTING:	Pos:	1	2	3	4	5	6	7	8
<b>Canada 2</b>	ON	▲	▲	▲	▲				
	OFF	▼	▼	▼	▼	▼	▼	▼	▼

CPU COUNTRY SETTING:	Pos:	1	2	3	4	5	6	7	8
<b>Middle East</b>	ON	▲	▲	▲	▲				
	OFF	▼	▼	▼	▼	▼	▼	▼	▼

CPU COUNTRY SETTING:	Pos:	1	2	3	4	5	6	7	8
<b>Switzerland</b>	ON	▲	▲	▲					
	OFF	▼	▼	▼	▼	▼	▼	▼	▼

CPU COUNTRY SETTING:	Pos:	1	2	3	4	5	6	7	8
<b>Croatia</b>	ON		▲	▲		▲			
	OFF	▼	▼	▼	▼	▼	▼	▼	▼

CPU COUNTRY SETTING:	Pos:	1	2	3	4	5	6	7	8
<b>Netherlands</b>	ON			▲					
	OFF	▼	▼	▼	▼	▼	▼	▼	▼

CPU COUNTRY SETTING:	Pos:	1	2	3	4	5	6	7	8
<b>Taiwan</b>	ON				▲	▲			
	OFF	▼	▼	▼	▼	▼	▼	▼	▼

CPU COUNTRY SETTING:	Pos:	1	2	3	4	5	6	7	8
<b>Denmark</b>	ON	▲			▲				
	OFF	▼	▼	▼	▼	▼	▼	▼	▼

CPU COUNTRY SETTING:	Pos:	1	2	3	4	5	6	7	8
<b>New Zealand</b>	ON					▲			
	OFF	▼	▼	▼	▼	▼	▼	▼	▼

CPU COUNTRY SETTING:	Pos:	1	2	3	4	5	6	7	8
<b>UK</b>	ON	▲	▲	▲					
	OFF	▼	▼	▼	▼	▼	▼	▼	▼

CPU COUNTRY SETTING:	Pos:	1	2	3	4	5	6	7	8
<b>Finland</b>	ON	▲		▲					
	OFF	▼	▼	▼	▼	▼	▼	▼	▼

CPU COUNTRY SETTING:	Pos:	1	2	3	4	5	6	7	8
<b>Norway</b>	ON		▲	▲					
	OFF	▼	▼	▼	▼	▼	▼	▼	▼

CPU/SND PCB SETTING:	Pos:	1	2	3	4	5	6	7	8
<b>UPDATE CODE</b>	ON								▲
	OFF	▼	▼	▼	▼	▼	▼	▼	▼

**Note:** Slide Dip Switch 8 to Position **ON** (with Dip Switches 1-7 in the **OFF** Position) only to reboot the game with the latest version **BOOT EPROM** installed at **U9** on the CPU/Sound Board (S.A.M. System only). Currently, this is also the procedure to update your game with the latest software code update file. For the latest version, visit our website. If you have questions about updating your game code, call Technical Support for assistance.



**Find-It-In-Front:**  
**Dr. Pinball**



**SWITCH MATRIX GRID (#1-#64) {Switch Locations on the next page}**

<b>01</b> <b>Q1</b> DRIVE GRN-BRN J1-P1	SW. # 1 LEFT LANE	500-6227-04 below playfield	SW. # 2 RIGHT LANE	500-6227-04 below playfield	SW. # 3 HIT CHEST	500-6775-00 above playfield	SW. # 4 PLUNDER EXIT	500-6775-00 above playfield	SW. # 5 NOT USED	180-5119-02 above playfield	SW. # 6 CHEST LOCK	180-5119-02 above playfield	SW. # 7 NOT USED	180-5087-00 above playfield	SW. # 8 LEFT ORBIT	180-5087-00 above playfield	SW. # 9 TOP CENTER VUK	180-5209-00 above playfield	SW. # 10 LEFT RAMP ENTER	180-5087-00 above playfield	SW. # 11 LEFT PLUNDER ENTER	500-6775-00 above playfield	SW. # 12 LEFT TOP LANE	180-5183-00 above playfield	SW. # 13 MIDDLE TOP LANE	180-5087-00 above playfield	SW. # 14 RIGHT TOP LANE	180-5183-00 above playfield	SW. # 15 TOURNAMENT START	180-5119-03 Front Molding	SW. # 16 START BUTTON	180-5174-00 In Cabinet	
<b>02</b> <b>Q2</b> DRIVE GRN-RED J1-P3	SW. # 17 NOT USED	(4-BALL) TROUGH #4 (L)	SW. # 18 NOT USED	(4-BALL) TROUGH #3	SW. # 19 NOT USED	(4-BALL) TROUGH #2	SW. # 20 NOT USED	(NUK OPTO) TROUGH #1 (R)	SW. # 21 NOT USED	(STACK OPTO) TROUGH JAM	SW. # 22 NOT USED	TRANS. / REC. Tx 515-0173-00 Rx 515-0174-00	SW. # 23 SHOOTER LANE	TRANS. / REC. Tx 515-0173-00 Rx 515-0174-00	SW. # 24 LEFT OUTLANE	500-6227-04 below playfield	SW. # 25 LEFT INLANE	500-6227-04 below playfield	SW. # 26 LEFT SLING	180-5054-00 2 per Asm.	SW. # 27 RIGHT SLING	180-5054-00 2 per Asm.	SW. # 28 RIGHT INLANE	500-6227-04 below playfield	SW. # 29 RIGHT OUTLANE	500-6227-04 below playfield	SW. # 30 LEFT BUMPER	180-5015-04 below playfield	SW. # 31 RIGHT BUMPER	180-5015-04 below playfield	SW. # 32 BOTTOM BUMPER	180-5015-04 below playfield	
<b>03</b> <b>Q3</b> DRIVE GRN-ORG J1-P4	SW. # 33 NOT USED	NOT USED	SW. # 34 NOT USED	NOT USED	SW. # 35 NOT USED	NOT USED	SW. # 36 NOT USED	L. BONUS TREA-SURE	SW. # 37 NOT USED	R. BONUS TREA-SURE	SW. # 38 NOT USED	SW. # 39 NOT USED	SW. # 40 NOT USED	SW. # 41 NOT USED	PLUNDER 1	180-5133-02 above playfield	SW. # 42 PLUNDER 2	180-5133-02 above playfield	SW. # 43 PLUNDER 3	180-5133-02 above playfield	SW. # 44 PLUNDER 4	180-5133-02 above playfield	SW. # 45 PLUNDER 5	180-5133-02 above playfield	SW. # 46 PLUNDER 6	180-5133-02 above playfield	SW. # 47 NOT USED	SW. # 48 NOT USED					
<b>04</b> <b>Q4</b> DRIVE GRN-YEL J1-P5	SW. # 49 NOT USED	PIRATE 1 (LEFT)	SW. # 50 PIRATE 2	PIRATE 2	SW. # 51 PIRATE 3	PIRATE 3	SW. # 52 PIRATE 4	PIRATE 4	SW. # 53 PIRATE 5	PIRATE 5	SW. # 54 PIRATE 6 (RIGHT)	GRN 1/2" SU 515-581-04 below playfield	SW. # 55 NOT USED	POP EJECT	180-5186-01 below playfield	SW. # 56 JACK SCOOP EXIT	180-5210-00 above playfield	SW. # 57 RIGHT ORBIT	180-5087-00 above playfield	SW. # 58 NOT USED	NOT USED	SW. # 59 NOT USED	NOT USED	SW. # 60 SKILL HOLE MADE	(OPTO PAIR) 500-6775-00 above playfield	SW. # 61 SHIP MADE	(OPTO PAIR) 500-6775-00 above playfield	SW. # 62 SHIP SUNK	180-5189-00 below playfield	SW. # 63 SHIP HOME	180-5189-00 below playfield	SW. # 64 NOT USED	NOT USED

Wire Color Abbreviations used:

BLK	BLU	BRN	GRY	GRN	LGN	ORG	PNK	RED	TAN	VIO	WHT	YEL
Black	Blue	Brown	Gray	Green	Light Gm.	Orange	Pink	Red	Tan	Violet	White	Yellow

**Dedicated Switches (D-1 – D-24) {Ded. Sw. Locations on the next page} // CPU/Snd. SW1 Dip Switches (1-8)**

<b>CPU/SND Board</b>	PNK-BRN J2-P2	PNK-RED J2-P3	PNK-ORG J2-P4	PNK-YEL J2-P6	PNK-BLU J2-P7	PNK-VIO J2-P9	PNK-GRY J3-P1	GRY-RED J3-P2	GRY-ORG J3-P4	GRY-YEL J3-P5	GRY-GRN J3-P6	GRY-BLU J3-P7	GRY-VIO J3-P8	GRY-BLK J3-P9		
<b>GROUND (BLK) J2-P1/1 &amp; J3-P10</b>	SW. D-1 LEFT COIN SLOT	SW. D-2 CENTER COIN SLOT/DBA	SW. D-3 RIGHT COIN SLOT	SW. D-4 FOURTH COIN SLOT	SW. D-5 FIFTH COIN SLOT	SW. D-6 NOT USED	SW. D-7 L. POST SAVE (UK ONLY)	SW. D-8 R. POST SAVE (UK ONLY)	SW. D-9 LEFT FLIPPER BUTTON	SW. D-10 LEFT FLIPPER E.O.S.	SW. D-11 R. FLIPPER BUTTON	SW. D-12 RIGHT FLIPPER E.O.S.	SW. D-13 NOT USED	SW. D-14 NOT USED	SW. D-15 NOT USED	SW. D-16 NOT USED
	180-5204-00 Coin Door	180-5204-00 Coin Door	180-5204-00 Coin Door	180-5204-00 Coin Door	180-5204-00 Coin Door	180-5160-01 Cabinet Side	180-5160-01 Cabinet Side	180-5149-00 Flipper Asm.	180-5160-01 Cabinet Side	180-5149-00 Flipper Asm.	180-5160-01 Cabinet Side	180-5149-00 Flipper Asm.	180-5149-00 Flipper Asm.	180-5149-00 Flipper Asm.	180-5149-00 Flipper Asm.	180-5149-00 Flipper Asm.

<b>CPU/SND Board</b>	LGN-BRN J13-P1	LGN-RED J13-P3	LGN-ORG J13-P4	LGN-YEL J13-P5	LGN-BLK J13-P6	LGN-BLU J13-P7	LGN-VIO J13-P8	LGN-GRY J13-P9	<b>CPU/SOUND BD. SW1 DIP SWITCH (located between Connectors J3/J13)</b>							
	SW. D-17	SW. D-18	SW. D-19	SW. D-20	SW. D-21	SW. D-22	SW. D-23	SW. D-24	SW. D-25	SW. D-26	SW. D-27	SW. D-28	SW. D-29	SW. D-30	SW. D-31	SW. D-32
	PENDULUM (PLUMB BOB)	SLAM	TICKET NOT USED	BACK (GREEN BUTTON)	MINUS (< / -) BUTTON	PLUS (> / +) RED BUTTON	SELECT (BLACK BUTTON)	DIP SWITCH POSITION #1	DIP SWITCH POSITION #2	DIP SWITCH POSITION #3	DIP SWITCH POSITION #4	DIP SWITCH POSITION #5	DIP SWITCH POSITION #6	DIP SWITCH POSITION #7	DIP SWITCH POSITION #8	

<b>GROUND (BLK) J13-P10</b>	TILT PENDULUM (PLUMB BOB)	SLAM	TICKET NOT USED	BACK (GREEN BUTTON)	MINUS (< / -) BUTTON	PLUS (> / +) RED BUTTON	SELECT (BLACK BUTTON)	DIP SWITCH POSITION #1	DIP SWITCH POSITION #2	DIP SWITCH POSITION #3	DIP SWITCH POSITION #4	DIP SWITCH POSITION #5	DIP SWITCH POSITION #6	DIP SWITCH POSITION #7	DIP SWITCH POSITION #8
	See Sec. 4, Cpp. 1, Pg. 47 for cab. parts	502-5032-00 Optional Kit	180-5119-02 Below Plf	180-5192-04 Coin Door	180-5192-02 Coin Door	180-5192-02 Coin Door	180-5192-02 Coin Door	ON / OFF	ON / OFF	ON / OFF	ON / OFF	ON / OFF	ON / OFF	ON / OFF	ON / OFF



Find-It-In-Front: Dr. Pinball



GO TO DIAGNOSTICS MENU

GO TO SWITCH MENU

SWITCH TEST

SWITCH MENU: SWITCH, ACTIVE, SINGLE & SERVICE

## SWITCH LOCATIONS {Switch Matrix Grid (01-64) on the previous page}

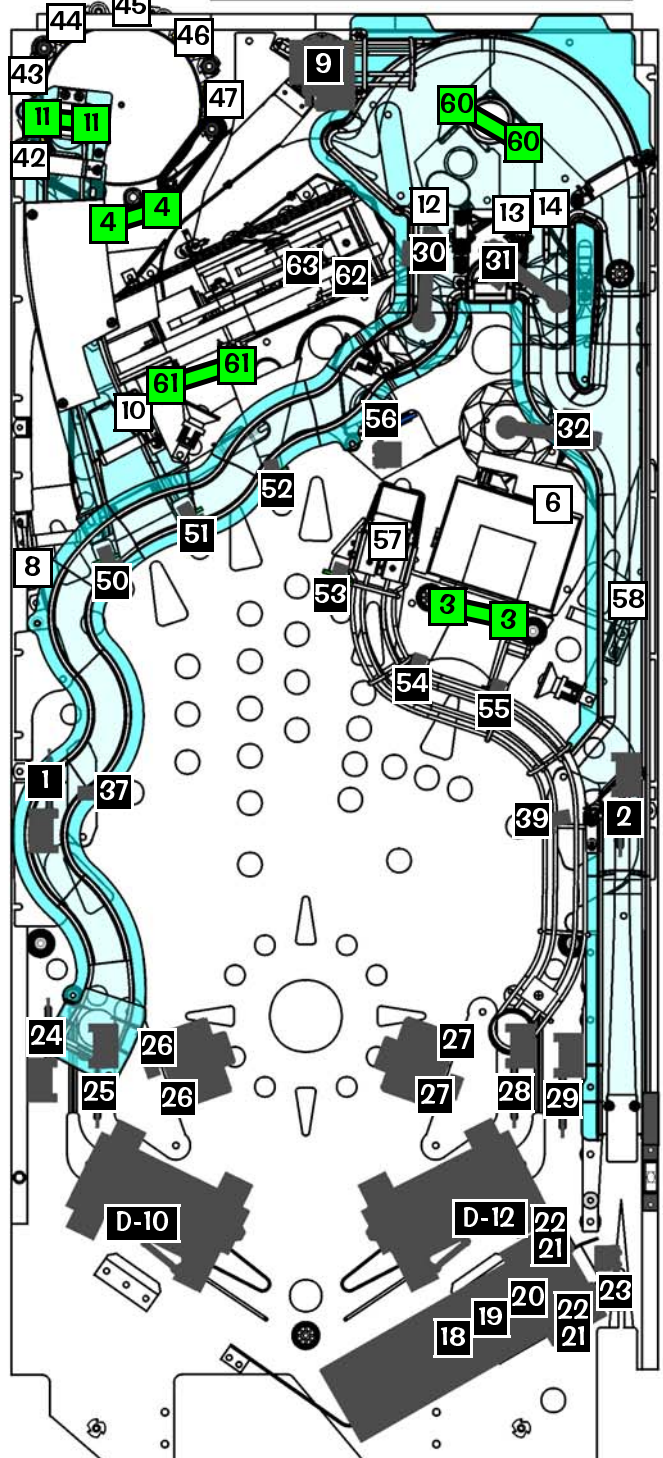
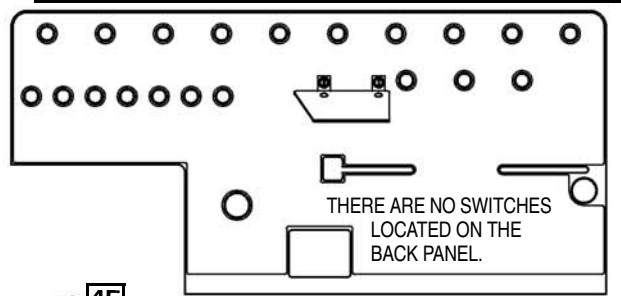

### Typical Switch Wiring & Schematic

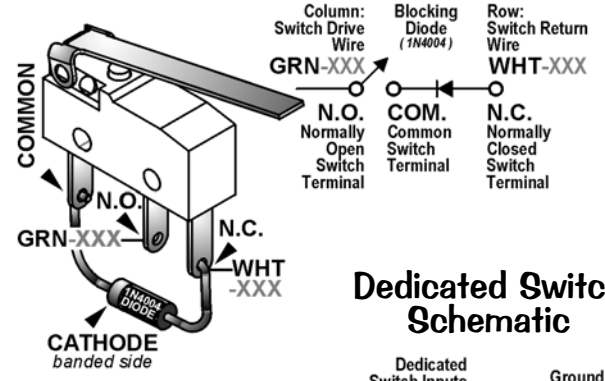

### Dedicated Switch Schematic

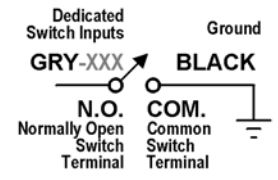

-XXX = Varying Wire Color. See Matrix Grid for color.

- = Switches above Playfield.
- = Switches below Playfield.
- = OPTO Switch Pairs above.

**Switch Part Notes:** ¥ Yen Coin Switch is 180-5091-00. Part Numbers which start with 515- or 500- include the bracket, target, and/or housing.

**Sw. D-17 Part Note:** The Switch is comprised of a Hanger Bracket (535-5319-00) and Contact Wire (535-7563-01) located in the Cabinet. Some Switch Diodes may be located under the playfield, in the Cabinet or Backbox on Terminal Strips or Diode Boards and not on the assemblies.

**DOTS:** D iode n terminal S trip, see Sec. 5, Chp.2, Playfield Wiring.

Find-It-In-Front:  
Dr. Pinball



## LAMP MATRIX GRID (01-80) {Lamp Locations on the next page}

I/O	01	02	03	04	05	06	07	08
Power Driver Board	IC-U17 18VDC YEL-BRN J13-P9	IC-U16 18VDC YEL-RED J13-P8	IC-U15 18VDC YEL-ORG J13-P7	IC-U14 18VDC YEL-BLK J13-P6	IC-U13 18VDC YEL-GRN J13-P5	IC-U12 18VDC YEL-BLU J13-P4	IC-U11 18VDC YEL-VIO J13-P3	IC-U10 18VDC YEL-GRY J13-P1
01 Q33 GROUND RED-BRN J12-P1	#555 Clear LP. #1 START BUTTON 165-5002-00	#CM86 Cir. LP. #2 TOURNAMENT START BUTTON 165-5103-00	#555 Clear LP. #3 SHOOT AGAIN 165-5002-00	#555 Clear LP. #4 LEFT OUTLANE 165-5002-00	#555 Clear LP. #5 LEFT INLANE 165-5002-00	#555 Clear LP. #6 RIGHT INLANE 165-5002-00	#555 Clear LP. #7 RIGHT OUTLANE 165-5002-00	#555 Clear LP. #8 FOUR WINDS (X2) 165-5002-00
02 Q34 GROUND RED-BLK J12-P2	#555 Clear LP. #9 COMPASS - NORTH 165-5002-00	#555 Clear LP. #10 COMPASS - SWORD FIGHT 165-5002-00	#555 Clear LP. #11 COMPASS - DAVY JONES 165-5002-00	#555 Clear LP. #12 COMPASS - EAST 165-5002-00	#555 Clear LP. #13 COMPASS - HEART SJP 165-5002-00	#555 Clear LP. #14 COMPASS - ALL PIRATES 165-5002-00	#555 Clear LP. #15 COMPASS - SOUTH 165-5002-00	#555 Clear LP. #16 COMPASS - PORT ROYAL 165-5002-00
03 Q35 GROUND RED-ORG J12-P3	#555 Clear LP. #17 COMPASS - KRAKEN 165-5002-00	#555 Clear LP. #18 COMPASS - WEST 165-5002-00	#555 Clear LP. #19 COMPASS - JACK/MONKEY 165-5002-00	#555 Clear LP. #20 COMPASS - SHIP SUNK 165-5002-00	#555 Clear LP. #21 RIGHT BONUS TREASURE 165-5002-00	#555 Clear LP. #22 LEFT SIDE LANE ARROW 165-5002-00	#555 Clear LP. #23 SHIP JACKPOT 165-5002-00	LED on PCB LP. #24 (H) EART 520-5258-00
04 Q36 GROUND RED-YEL J12-P4	#555 Clear LP. #25 DAVY JONES 165-5002-00	#555 Clear LP. #26 TIMED BALL LOCK 165-5002-00	#555 LED LP. #27 POP BUMP- ER (X3) 112-5024-08	#555 Clear LP. #28 LEFT ORBIT ARROW 165-5002-00	#555 Clear LP. #29 LEFT ORBIT JACKPOT 165-5002-00	#555 Clear LP. #30 RIGHT ORBIT JACKPOT 165-5002-00	#555 Clear LP. #31 RIGHT SPECIAL 165-5002-00	LED on PCB LP. #32 H (E) ART 520-5258-00
05 Q37 GROUND RED-GRN J12-P5	#44 Red LP. #33 BACKPANEL #1 (L) 165-5053-02-HF	#44 Red LP. #34 BACKPANEL #2 165-5053-02-HF	#44 Red LP. #35 BACKPANEL #3 165-5053-02-HF	#44 Red LP. #36 BACKPANEL #4 165-5053-02-HF	#44 Red LP. #37 BACKPANEL #5 165-5053-02-HF	#44 Red LP. #38 BACKPANEL #6 165-5053-02-HF	#44 Red LP. #39 BACKPANEL #7 (R) 165-5053-02-HF	LED on PCB LP. #40 HE (A) RT 520-5258-00
06 Q38 GROUND RED-BLU J12-P6	#555 Clear LP. #41 PIRATE 6 165-5002-00	#555 Clear LP. #42 LEFT SPECIAL 165-5002-00	#555 Clear LP. #43 LEFT BONUS TREASURE 165-5002-00	#555 Clear LP. #44 CHEST ARROW 165-5002-00	#555 Clear LP. #45 LEFT RAMP ARROW 165-5002-00	#555 Clear LP. #46 PORT ROYAL 165-5002-00	#555 Clear LP. #47 TORTUGA 165-5002-00	LED on PCB LP. #48 HEA (R) T 520-5258-00
07 Q39 GROUND RED-VIO J12-P8	#555 Clear LP. #49 PIRATE 1 165-5002-00	#555 Clear LP. #50 PIRATE 2 165-5002-00	#555 Clear LP. #51 PIRATE 3 165-5002-00	#555 Clear LP. #52 PIRATE 4 165-5002-00	#555 Clear LP. #53 PIRATE 5 165-5002-00	#555 Clear LP. #54 HEART MULTIBALL 165-5002-00	#555 Clear LP. #55 KE (Y) 165-5002-00	LED on PCB LP. #56 LED on PCB LP. #56 520-5258-00
08 Q40 GROUND RED-GRY J12-P9	#555 Clear LP. #57 SCOOP ARROW 165-5002-00	#555 Clear LP. #58 (J) ACK 165-5002-00	#555 Clear LP. #59 J (A) CK 165-5002-00	#555 Clear LP. #60 JA (C) K 165-5002-00	#555 Clear LP. #61 JAC (K) 165-5002-00	Lamp Note 1 LP. #62 (K) EY 112-5024-08	#555 Clear LP. #63 K (E) Y 165-5002-00	LEDs / PCB LP. #64 HEART 1(double-dot) 520-5258-00
09 Q41 GROUND RED-WHT J12-P10	#555 Clear LP. #65 SHIP ARROW 165-5002-00	#555 Clear LP. #66 INTERCEPTOR 165-5002-00	#44 Blue LP. #67 DAUNTLESS 165-5053-05-HF	#44 Blue LP. #68 EDINBURGH TRADER 165-5053-05-HF	#555 Clear LP. #69 TERPSICHORE 165-5002-00	Lamp Note 1 LP. #70 AWARD COMPASS 112-5024-08	#555 Clear LP. #71 RIGHT ORBIT ARROW 165-5002-00	LEDs / PCB LP. #72 LEDS / PCB LP. #72 HEART 2(double-dot) 520-5258-00
10 Q42 GROUND RED J12-P11	#44 Red LP. #73 KRAKEN MOUTH 165-5053-02-HF	#555 Clear LP. #74 CENTER ARROW 165-5002-00	#44 Blue LP. #75 CENTER JACKPOT 165-5053-05-HF	#44 Blue LP. #76 EXTRA BALL 165-5053-05-HF	#555 Clear LP. #77 LIARS DICE 165-5053-05-HF	#44 Green LP. #78 LEFT TOP LANE 165-5053-04-HF	#44 Green LP. #79 MIDDLE TOP LANE 165-5053-04-HF	#44 Green LP. #80 RIGHT TOP LANE 165-5053-04-HF



Find-It-In-Front:  
Dr. Pinball



Wire Color Abbreviations used:

BLK	BLU	BRN	GRY	GRN	ORG	RED	VIO	WHT	YEL
Black	Blue	Brown	Gray	Green	Orange	Red	Violet	White	Yellow

Lamp Note 1 = White LED Module (Wedge Base #555 Style) 112-5024-08  
Bulbs in Sockets using beige/white plastic brackets, are #555  
In Metal Sockets are #44, Lamps 33-39 and 78-80, see Page 91.



GO TO DIAGNOSTICS MENU

GO TO LAMP MENU

SINGLE LAMP TEST

LAMP MENU: ONE, ALL, ROW, COLUMN & ORDERED

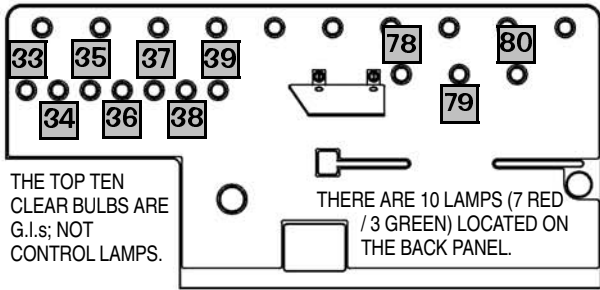

## LAMP LOCATIONS

{Lamp Matrix Grid (01-80) on the previous page}

### Typical Lamp Schematic & Wiring

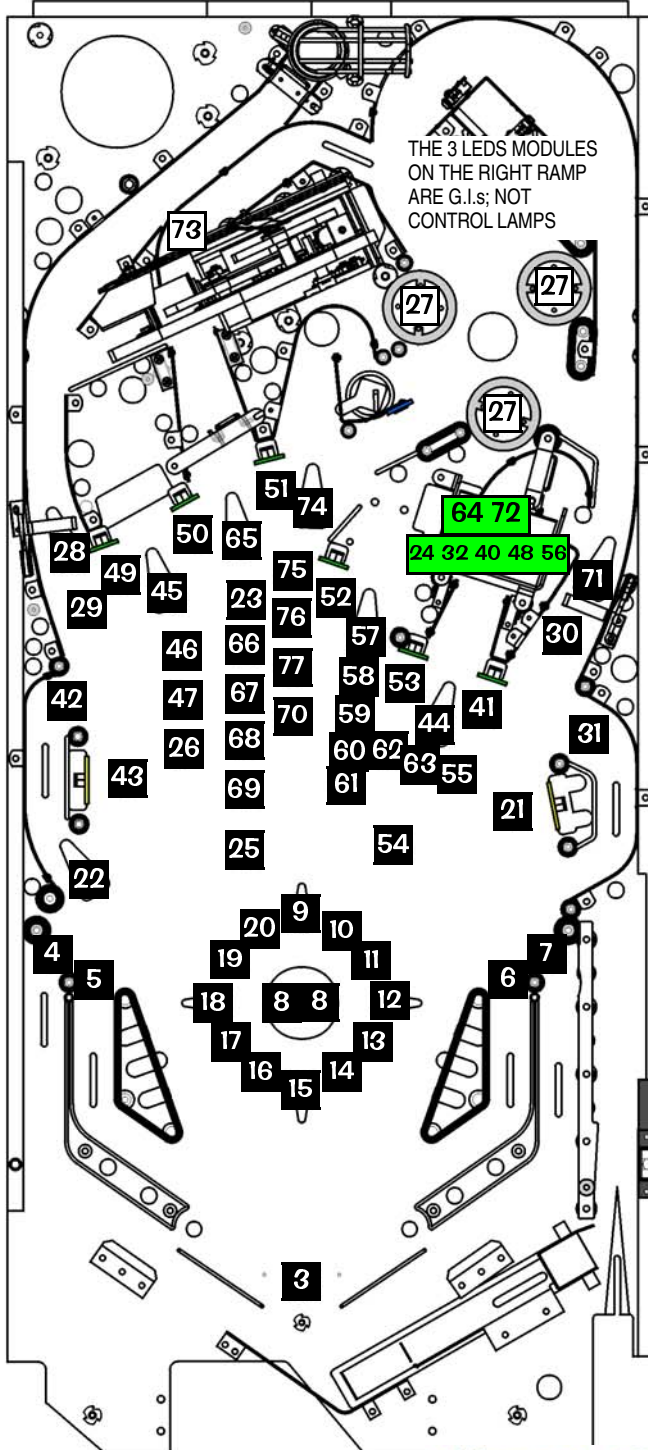
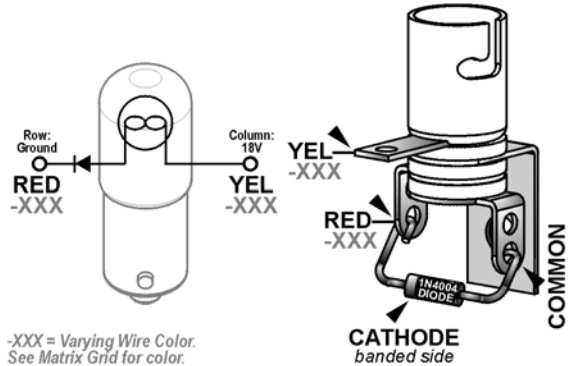

- = Lamps above Playfield.
- = Lamps below Playfield.
- = Lamps on Back Panel.  = LEDs on PCB.

**Lamp Part Notes:** #555 Wedge Base (W.B.) Bulb Clear = 165-5002-00.  
#44 Bayonet Bulb (Heavy Filament) Clear = 165-5000-44-HF.

See Section 4, Chapter 1, **Parts Identification & Location**, Pages 62-64 for more details on bulbs and corresponding sockets. **Some Lamp Diodes may be located under the playfield, in the Cabinet or Backbox on Terminal Strips and not on or with the Lamp Socket.**

**DOTS:** Diode On Terminal Strip, see Sec. 5, Chp. 2, **Playfield Wiring**.

# COILS DETAILED CHART TABLE

High Current Coils Group 1		Drive Transistor	Driver Output Board	Power Line Color	Power Line Connection	Power Voltage	Drive Transistor Control Line Color	D.T. Control Line Connect	Coil GA-Turn or Bulb Type
#1	TROUGH UP-KICKER	Q1	▲ I/O Power Driver ▼	YEL-VIO	J10-P9/10	50v DC	BRN-BLK	J8-P1	26-1200 ∪ 090-5044-00-ND
#2	AUTO LAUNCH	Q2		YEL-VIO	J10-P9/10	50v DC	BRN-RED	J8-P3	23-800 ∪ 090-5001-00-ND
#3	TOP CENTER VUK	Q3		YEL-VIO	J10-P9/10	50v DC	BRN-ORG	J8-P4	26-1200 ∪ 090-5044-00-ND
#4	CHEST LID	Q4		YEL-VIO	J10-P9/10	50v DC	BRN-YEL	J8-P5	27-1400 ∪ 511-5031-00
#5	RAISE SAILS	Q5		YEL-VIO	J10-P9/10	50v DC	BRN-GRN	J8-P6	26-1200 ∪ 500-7051-00
#6	PLUNDER DISK MOTOR	Q6		BROWN	J10-P9/10	20v DC	BRN-BLU	J8-P7	Motor 12V 511-5024-04
#7	NOT USED	Q7			J10-P9/10		BRN-VIO	J8-P8	
#8	NOT USED	Q8			J10-P9/10		BRN-GRY	J8-P9	

High Current Coils Group 2		Drive Transistor	Driver Output Board	Power Line Color	Power Line Connection	Power Voltage	Drive Transistor Control Line Color	D.T. Control Line Connect	Coil GA-Turn or Bulb Type
#9	LEFT BUMPER	Q9	▲ I/O Power Driver ▼	YEL-VIO	J10-P9/10	50v DC	BLU-BRN	J9-P1	26-1200 ∪ 090-5044-00-ND
#10	RIGHT BUMPER	Q10		YEL-VIO	J10-P9/10	50v DC	BLU-RED	J9-P2	26-1200 ∪ 090-5044-00-ND
#11	BOTTOM BUMPER	Q11		YEL-VIO	J10-P9/10	50v DC	BLU-ORG	J9-P4	26-1200 ∪ 090-5044-00-ND
#12	NOT USED	Q12			J10-P9/10		BLU-YEL	J9-P5	
#13	NOT USED	Q13			J10-P9/10		BLU-GRN	J9-P6	
#14	NOT USED	Q14			J10-P6/7		BLU-BLK	J9-P7	
#15	LEFT FLIPPER (50v RED/YEL)	Q15		GRY-YEL-3A Fuse-RED-YEL	J10-P6/7	50v DC	ORG-GRY	J9-P8	23-1100 ∪ 090-5030-00-ND
#16	RIGHT FLIPPER (50v RED/YEL)	Q16		BLU-YEL-3A Fuse-RED-YEL	J10-P6/7	50v DC	ORG-VIO	J9-P9	23-1100 ∪ 090-5030-00-ND

Low Current Coils Group 1		Drive Transistor	Driver Output Board	Power Line Color	Power Line Connection	Power Voltage	Drive Transistor Control Line Color	D.T. Control Line Connect	Coil GA-Turn or Bulb Type
#17	NOT USED	Q17	▲ I/O Power Driver ▼		J7-P1		VIO-BRN	J7-P2	
#18	POP BUMPER EJECT	Q18		BROWN	J7-P1	20v DC	VIO-RED	J7-P3	26-1200 ∪ 090-5044-00-ND
#19	CHEST KICKER	Q19		BROWN	J7-P1	20v DC	VIO-ORG	J7-P4	26-1200 ∪ 090-5044-00-ND
#20	FLASH: CHEST	Q20		ORANGE	J7-P1	20v DC	VIO-WHT	J7-P6	#89 Bulb 165-5000-89
#21	SHIP MOTOR	Q21		BROWN	J7-P1	20v DC	VIO-GRN	J7-P7	Motor 24V 041-5101-00
#22	FLASH: REAR CENTER (X2)	Q22		ORANGE	J7-P1	20v DC	VIO-BLU	J7-P8	#89 Bulb 165-5000-89
#23	PLUNDER PIN	Q23		BROWN	J7-P1	20v DC	VIO-BLK	J7-P9	22-900 ∪ 090-5020-20-ND
#24	OPTIONAL COIL	Q24		RED	J16-P4>8	5v DC	VIO-GRY	J7-P10	Opt. 5v

Diode On Terminal Strip (if noted)

Low Current Coils Group 2		Drive Transistor	Driver Output Board	Power Line Color	Power Line Connection	Power Voltage	Drive Transistor Control Line Color	D.T. Control Line Connect	Coil GA-Turn or Bulb Type
#25	LEFT SLINGSHOT	Q25	▲ I/O Power Driver ▼	BROWN	J6-P10	20v DC	BLK-BRN	J6-P1	23-800 ∪ 090-5001-00-ND
#26	RIGHT SLINGSHOT	Q26		BROWN	J6-P10	20v DC	BLK-RED	J6-P2	23-800 ∪ 090-5001-00-ND
#27	SHIP MOTOR RELAY	Q27		BROWN	J6-P10	20v DC	BLK-ORG	J6-P3	Relay PCB 511-5024-03
#28	LOWER SAILS LATCH	Q28		BROWN	J6-P10	20v DC	BLK-YEL	J6-P4	29-1400 ∪ 500-7052-00
#29	SHIP PIN [UP POST]	Q29		BROWN	J6-P10	20v DC	BLK-GRN	J6-P5	26-1200 ∪ 090-5044-00-ND
#30	FLASH: BACK RIGHT [X3]	Q30		ORANGE	J6-P10	20v DC	BLK-BLU	J6-P6	#89 Bulb 165-5000-89
#31	FLASH: BACK LEFT	Q31		ORANGE	J6-P10	20v DC	BLK-VIO	J6-P7	#89 Bulb 165-5000-89
#32	FLASH: SHIP	Q32		ORANGE	J6-P10	20v DC	BLK-GRY	J6-P8	#89 Bulb 165-5000-89

Note: In Test Flash Lamps Menu ("Flash" Icon), Flashers tested are all Flash Lamps located between Q1-Q32 (This Game: Q20, Q22, Q30, Q31 & Q32)

∪ Coil Note: ∪ -ND means 'No Diode'. -00B or -00T can be used for coil replacements, but the diode must be removed. Call for more info.



GO TO DIAGNOSTICS MENU

GO TO COIL MENU

SINGLE COIL TEST

COIL MENU: SINGLE COIL & CYCLING COIL

## COIL & FLASH LAMP LOCATIONS

{Coils Detailed Chart Table on the previous page}

### Typical Coil Wiring & Schematic

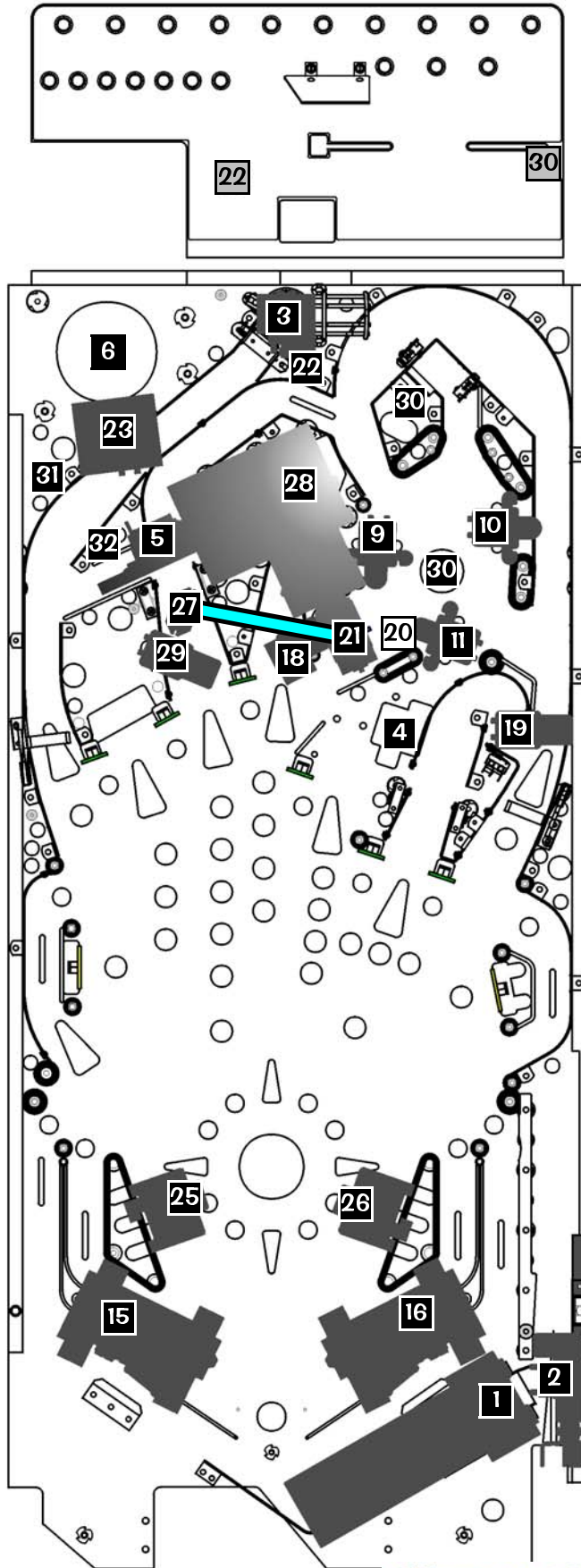
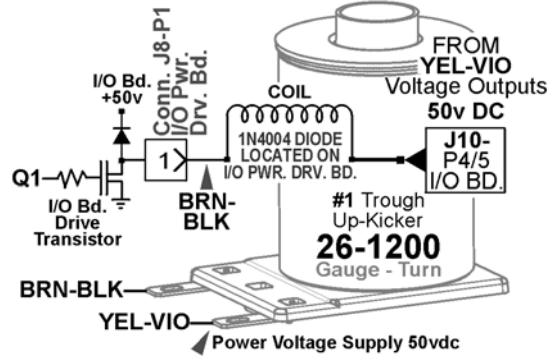

- = Coils / Flash Lamps above Playfield.
- = Coils / Flash Lamps below Playfield.
- = Coils / Flash Lamps on Back Panel.
- Color = Color of Mini-Mars or Flash Lamp Bulb.

*Coil Q24 is Optional. If either a Coin Meter, Token Dispenser or Knocker (all optional equipment) is required, call Technical Support for more information, 1-800-542-5377 or 1-708-345-7700.*

*DOTS:  $\square$  iode  $\square$  n  $\square$  terminal  $\square$  trip, see Sec. 5, Chp. 2, Playfield Wiring.*



STANDARD ADJUSTMENT #1

## GO TO ADJUSTMENTS MENU: STANDARD ADJUSTMENTS [ #1 – #63 ]

Perform the below steps to review the adjustments. Enter the **SERVICE MENU**, then enter the **STANDARD ADJUSTMENTS MENU**. For adjustment definitions or summary, review Section 3, Chapter 4, **GO TO ADJUSTMENTS MENU**. See Section 3, Chapter 5, **GO TO INSTALLS MENU** (via the **UTILITIES MENU**), to easily change all adjustments required depending on the Install Type (Easy, Hard, 5-Ball, Home Play, etc.) desired.

**Step 1** Press [ **SELECT** ]. Press [ **BACK** ] to exit or escape at any time.

**Step 2** Press [ **>** ]. Go to the "ADJ" Icon. Press [ **SELECT** ].

**Step 3** ... "S.P.I." Icon. Press [ **SELECT** ].



**Step 4** **STANDARD ADJUSTMENT #1** appears with the Adjustment Name [ **REPLAY TYPE** ] flashing. With the Adjustment Name flashing, press [ **<** ] [ **>** ] to move between adjustments.

**Step 5:** To change the Adjustment Setting, press [ **SELECT** ]. With the Adjustment Setting flashing, press [ **<** ] [ **>** ] repeatedly until the desired setting appears. Press the [ **SELECT** ] to "install" the change. The Adjustment Comment (bottom text line) will indicate [ **INSTALLED/FACTORY DEFAULT** ], if the Factory Default Setting is selected or [ **INSTALLED** ] if the change is not the Factory Default Setting.

## STANDARD ADJUSTMENTS [ #1 – #63 ] ▼

Nr.	STANDARD ADJUSTMENT NAME	USA DEFAULT	YOUR SETTING
1	REPLAY TYPE	AUTO	
2	‡ REPLAY PERCENTAGE	10%	
3	‡ REPLAY AWARD	CREDIT	
4	‡ REPLAY LEVELS	1	
5	‡ AUTO REPLAY START	20,000,000	
6	‡ DYNAMIC REPLAY START	60,000,000	
7	‡ REPLAY LEVEL #1	15,000,000	
8	‡ REPLAY LEVEL #2	30,000,000	
9	‡ REPLAY LEVEL #3	45,000,000	
10	‡ REPLAY LEVEL #4	60,000,000	
11	‡ REPLAY BOOST	YES	
12	SPECIAL LIMIT	1	
13	‡ SPECIAL PERCENTAGE	10%	
14	SPECIAL AWARD	CREDIT	
15	FREE GAME LIMIT	5	
16	EXTRA BALL LIMIT	5	
17	‡ EXTRA BALL PERCENTAGE	25%	
18	GAME PRICING	USA 5	
19	MATCH PERCENTAGE	9%	
20	MATCH AWARD	CREDIT	
21	BALLS PER GAME	3	
22	TILT WARNINGS	2	
23	CREDIT LIMIT	30	
24	ALLOW HIGH SCORES	YES	
25	HIGH SCORE AWARD	CREDIT	
26	GRAND CHAMPION AWARDS	1	
27	HIGH SCORE #1 AWARDS	1	
28	HIGH SCORE #2 AWARDS	0	
29	HIGH SCORE #3 AWARDS	0	
30	HIGH SCORE #4 AWARDS	0	
31	GRAND CHAMPION SCORE	75,000,000	

Nr.	STANDARD ADJUSTMENT NAME	USA DEFAULT	YOUR SETTING
32	HIGH SCORE #1	55,000,000	
33	HIGH SCORE #2	40,000,000	
34	HIGH SCORE #3	30,000,000	
35	HIGH SCORE #4	25,000,000	
36	HSTD INITIALS	3 INITIALS	
37	HSTD RESET COUNT	2000	
38	FREE PLAY	NO	
39	LANGUAGE	ENGLISH	
40	PLAYER LANGUAGE SELECT	YES	
41	CUSTOM MESSAGE	ON	
42	FLASH LAMP POWER	NORMAL	
43	COIL PULSE POWER	NORMAL	
44	KNOCKER VOLUME	NORMAL	
45	GAME RESTART	YES	
46	BILL VALIDATOR	NO	
47	MUSIC VOLUME	1	
48	BALL SAVE TIME	0:05	
49	TIMED PLUNGER	OFF	
50	FLIPPER BALL LAUNCH	OFF	
51	COINDOOR BALL SAVER	NO	
52	COMPETITION MODE	NO	
53	CONSOLATION BALL	YES	
54	FAST BOOT	YES	
55	Q24 OPTION	COIN METER	
56	TICKET DISPENSER	NO	
57	PLAYER COMPETITION	YES	
58	TEAM SCORES	NO	
59	LOCATION ID	0	
60	GAME ID	0	
61	TIME FORMAT	12-HOUR	
62	COIN INPUT DELAY	30	
63	LOST BALL RECOVERY	YES	

*Factory Defaults Settings are subject to change during production (especially Standard Adjustments 2, 4, 5, 13, 16-17, 19, 31-35 & 47).*

*‡ Not all Standard Adjustments are shown. Depending on the setting (whether Factory Default or if changed by the operator), associated adjustments do not appear, if not required. Note: If Game Dip Switch other than USA is installed, different Defaults will appear.*





## GO TO ADJUSTMENTS MENU: FEATURE ADJUSTMENTS [ #1 – #14 ]

Perform the below steps to review the adjustments. Enter the **SERVICE MENU**, then enter the **FEATURE ADJUSTMENTS MENU**. For adjustment definitions or summary, review Section 3, Chapter 4, **GO TO ADJUSTMENTS MENU**. See Section 3, Chapter 5, **GO TO INSTALLS MENU** (via the **UTILITIES MENU**), to easily change all adjustments required depending on the Install Type (Easy, Hard, 5-Ball, Home Play, etc.) desired.

**Step 1** Press [ **SELECT** ]. Press [ **BACK** ] to exit or escape at any time.

**Step 2** Press [ **>** ]. Go to the "ADJ" Icon. Press [ **SELECT** ].

**Step 3** Press [ **>** ]. Go to the "GAME" Icon. Press [ **SELECT** ].



**Step 4** **FEATURE ADJUSTMENT #1** appears with the Adjustment Name [ **FEATURE ADJUST. NAME** ] flashing. With the Adjustment Name flashing, press [ **<** ] [ **>** ] to move between adjustments.

**Step 5:** To change the Adjustment Setting, press [ **SELECT** ]. With the Adjustment Setting flashing, press [ **<** ] [ **>** ] repeatedly until the desired setting appears. Press the [ **SELECT** ] to "install" the change. The Adjustment Comment (bottom text line) will indicate [ **INSTALLED/FACTORY DEFAULT** ], if the Factory Default Setting is selected or [ **INSTALLED** ] if the change is not the Factory Default Setting.

## FEATURE ADJUSTMENTS [ #1 – #14 ] ▼

Nr.	FEATURE ADJUSTMENT NAME	USA DEFAULT	YOUR SETTING
1	SINK SHIP DIFFICULTY	MEDIUM	
2	KRAKEN DIFFICULTY	MEDIUM	
3	PORT ROYAL DIFFICULTY	MEDIUM	
4	DAVY JONES DIFFICULTY	MEDIUM	
5	1ST EXTRA BALL FROM TREASURE	25	
6	TREASURES TO NEXT EXTRA BALL	50	
7	CHEST DIFFICULTY	MEDIUM	

Nr.	FEATURE ADJUSTMENT NAME	USA DEFAULT	YOUR SETTING
8	PARLAY DIFFICULTY	MEDIUM	
9	BROADSIDE DIFFICULTY	MEDIUM	
10	HEART MULTIBALL DIFFICULTY	MEDIUM	
11	PIRATE KING	25	
12	GAUNTLET CHAMPION 1	15	
13	GAUNTLET CHAMPION 2	10	
14	GAUNTLET CHAMPION 3	05	

**Factory Defaults Settings are subject to change during production**  
**Note:** If Game Dip Switch other than USA is installed, different Defaults will appear.



Find-It-In-Front:  
Dr. Pinball





CHOOSE EARNINGS or STANDARD AUDITS

## GO TO AUDITS MENU: EARNINGS AUDITS [ #1 – #13 ] / STANDARD AUDITS [ #1 – #59 ]

Perform the below steps to review the audits. Enter the **SERVICE MENU**, then enter the **EARNINGS AUDITS** or **STANDARD AUDITS** MENUS. For audit definitions or summary, review Section 3, Chapter 3, **GO TO AUDITS MENU**. **Coming Soon!** Audits / pertinent game data can be downloaded from the **USB MENU** (via the **UTILITIES MENU**), select the "DUMP" Icon. See Section 3, Chp. 5, **GO TO UTILITIES MENU**, for more information.

**Step 1** Press [ **SELECT** ].  
Press [ **BACK** ] to exit or escape at any time.



**Step 2** Press [ **>** ]. Go to the "AUD" Icon.  
Press [ **SELECT** ].

### EARNINGS AUDITS [ #1 – #13 ] ▼

**Step 3** Press [ **>** ]. Go to the "EARN" or "S.P.I." Icon.  
Press [ **SELECT** ].

Nr.	EARNINGS AUDIT NAME	YOUR RESULT
1	TOTAL PAID CREDITS	
2	FREE GAME PERCENTAGE	
3	AVERAGE BALL TIME	
4	AVERAGE GAME TIME	
5	COINS THROUGH LEFT SLOT	
6	COINS THROUGH RIGHT SLOT	
7	COINS THROUGH CENTER SLOT	

Nr.	EARNINGS AUDIT NAME	YOUR RESULT
8	COINS THROUGH FOURTH SLOT	
9	COINS THROUGH FIFTH SLOT	
10	TOTAL COINS	
11	TOTAL EARNINGS	
12	METER CLICKS	
13	SOFTWARE METER	

**Step 4** Press [ **<** ] [ **>** ] to move between audits.

### STANDARD AUDITS [ #1 – #59 ] ▼

Nr.	STANDARD AUDIT NAME	YOUR RESULT
1	TOTAL BALLS PLAYED	
2	TOTAL EXTRA BALLS	
3	EXTRA BALL PERCENTAGE	
4	REPLAY 1 AWARDS	
5	REPLAY 2 AWARDS	
6	REPLAY 3 AWARDS	
7	REPLAY 4 AWARDS	
8	TOTAL REPLAYS	
9	REPLAY PERCENTAGE	
10	TOTAL SPECIALS	
11	SPECIAL PERCENTAGE	
12	TOTAL MATCHES	
13	HIGH SCORE AWARDS	
14	HIGH SCORE PERCENT	
15	TOTAL FREE PLAYS	
16	TOTAL PLAYS	
17	0.0M – 1.99M SCORES	
18	2.0M – 3.99M SCORES	
19	4.0M – 5.99M SCORES	
20	6.0M – 7.99M SCORES	

Nr.	STANDARD AUDIT NAME	YOUR RESULT
21	8.0M – 9.99M SCORES	
22	10.0M – 12.49M SCORES	
23	12.5M – 14.99M SCORES	
24	15.0M – 17.49M SCORES	
25	17.5M – 19.99M SCORES	
26	20.0M – 24.99M SCORES	
27	25.0M – 29.99M SCORES	
28	30.0M – 39.99M SCORES	
29	40.0M – 49.99M SCORES	
30	50.0M – 74.99M SCORES	
31	75.0M – 99.99M SCORES	
32	100.0M – 149.99M SCORES	
33	150.0M+ SCORES	
34	AVERAGE SCORES	
35	SERVICE CREDITS	
36	BALL SEARCH STARTED	
37	LOST BALL FEEDS	
38	LOST BALL GAME STARTS	
39	LEFT DRAINS	
40	CENTER DRAINS	

Nr.	STANDARD AUDIT NAME	YOUR RESULT
41	RIGHT DRAINS	
42	TILTS	
43	TOTAL BALLS SAVED	
44	LEFT FLIPPER USED	
45	RIGHT FLIPPER USED	
46	0 – 1 MINUTE GAMES	
47	1 – 1.5 MINUTE GAMES	
48	1.5 – 2 MINUTE GAMES	
49	2 – 2.5 MINUTE GAMES	
50	2.5 – 3 MINUTE GAMES	
51	3 – 3.5 MINUTE GAMES	
52	3.5 – 4 MINUTE GAMES	
53	4 – 5 MINUTE GAMES	
54	5 – 6 MINUTE GAMES	
55	6 – 8 MINUTE GAMES	
56	8 – 10 MINUTE GAMES	
57	10 – 15 MINUTE GAMES	
58	15+ MINUTE GAMES	
59	RECENT REPLAY PERCENT	

Note: Audits are subject to change (with or without notice).





FEATURE AUDIT 1

## GO TO AUDITS MENU: FEATURE AUDITS [ #1 – #40 ]

Perform the below steps to review the audits. Enter the **SERVICE MENU**, then enter the **FEATURE AUDITS MENU**. For Tournament Audit definitions and table, review Section 3, Chapter 6, **GO TO TOURNAMENTS MENU**.

**Step 1** Press [ **SELECT** ]. Press [ **BACK** ] to exit or escape at any time.

**Step 2** Press [ **>** ]. Go to the "AUD" icon.  
Press [ **SELECT** ].

**Step 3** Press [ **>** ]. Go to the "GAME" icon. Press [ **SELECT** ].

**Step 4** Press [ **<** ] [ **>** ] to move between audits.

Audit Number  
Audit Name  
Audit Result



## FEATURE AUDITS [ #1 – #40 ] ▼

Nr.	FEATURE AUDIT NAME	YOUR RESULT
1	MADE PARLAY LANE	
2	LEFT TOP LANE	
3	RIGHT TOP LANE	
4	RIGHT TOP LANE	
5	ALL TOP LANES	
6	MADE LEFT ORBIT	
7	ENTER LEFT RAMP	
8	MADE LEFT RAMP	
9	DISK TARGETS	
10	LEFT SIDE LANE	
11	RIGHT SIDE LANE	
12	MADE JACK SCOOP	
13	MADE CHEST	

Nr.	FEATURE AUDIT NAME	YOUR RESULT
14	HIT SHIP	
15	DESTROY SAILS	
16	SINK SHIP	
17	KRAKEN JACKPOT	
18	DESTROY KRAKEN	
19	HEART MULTIBALL	
20	HEART JACKPOTS	
21	HEART SUPER JP (JACKPOTS)	
22	EXTRA BALLS	
23	LIARS DICE	
24	LD (LIARS DICE) BIG POINTS AWARD	
25	LD MULTIPLIERS HELD AWARDS	
26	LD BONUS MULTIPLIERS AWARDS	

Nr.	FEATURE AUDIT NAME	YOUR RESULT
27	LD LIGHT CHEST AWARDS	
28	LD LIGHT LOCK AWARDS	
29	LD LIGHT PARLAY AWARDS	
30	LD LIGHT SPECIAL AWARDS	
31	LD LIGHT EXTRA BALL AWARDS	
32	LD DROP SAILS AWARDS	
33	LD LITTLE POINTS AWARDS	
34	COMPASS NORTH	
35	COMPASS SOUTH	
36	COMPASS EAST	
37	COMPASS WEST	
38	LIT FOUR WINDS	
39	FOUR WINDS	
40	COMPLETED FOUR WINDS	

Note: Audits are subject to change (with or without notice).



Find-It-In-Front:  
Dr. Pinball



## Domestic Pinball & Redemption Distributors Map

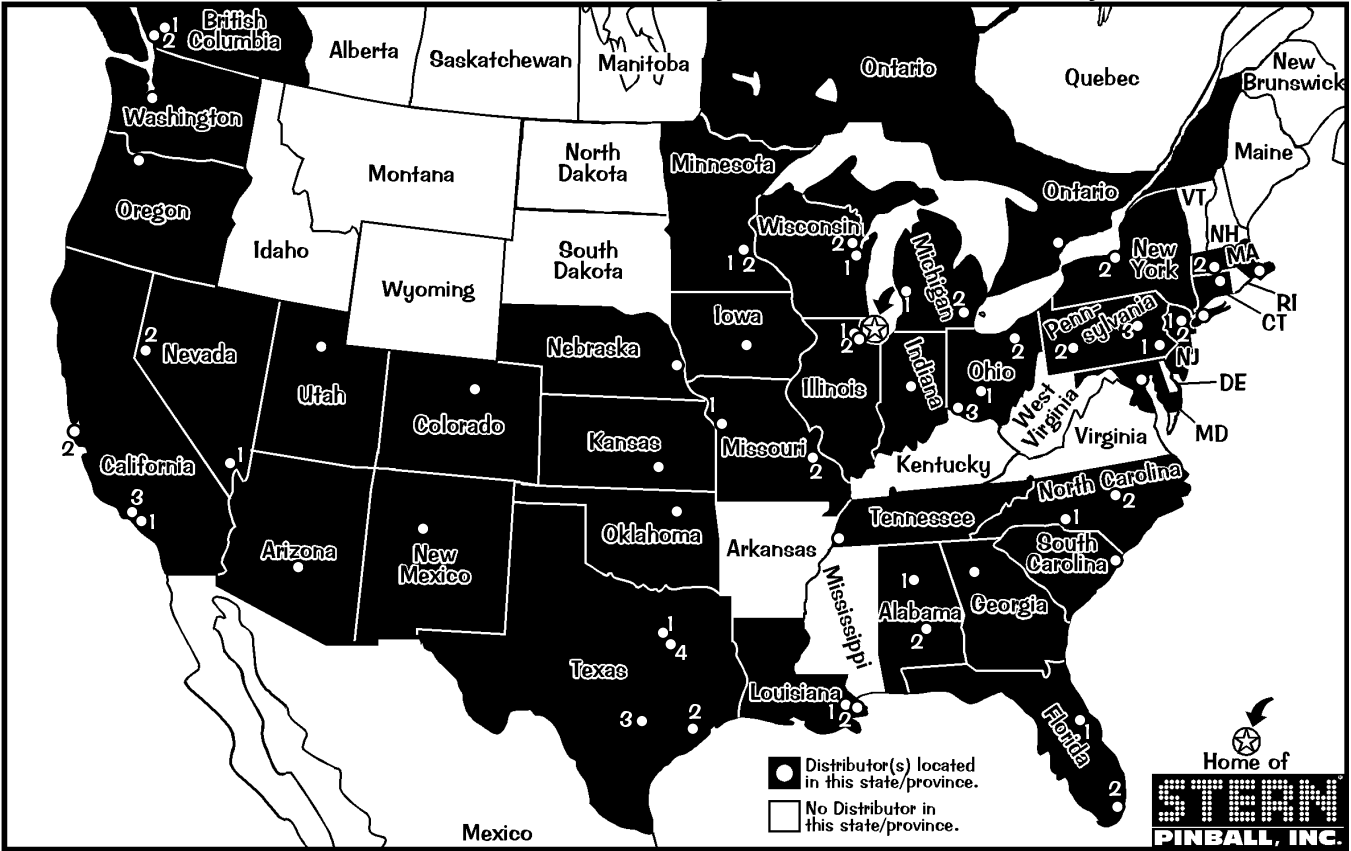

## International Distributors Map

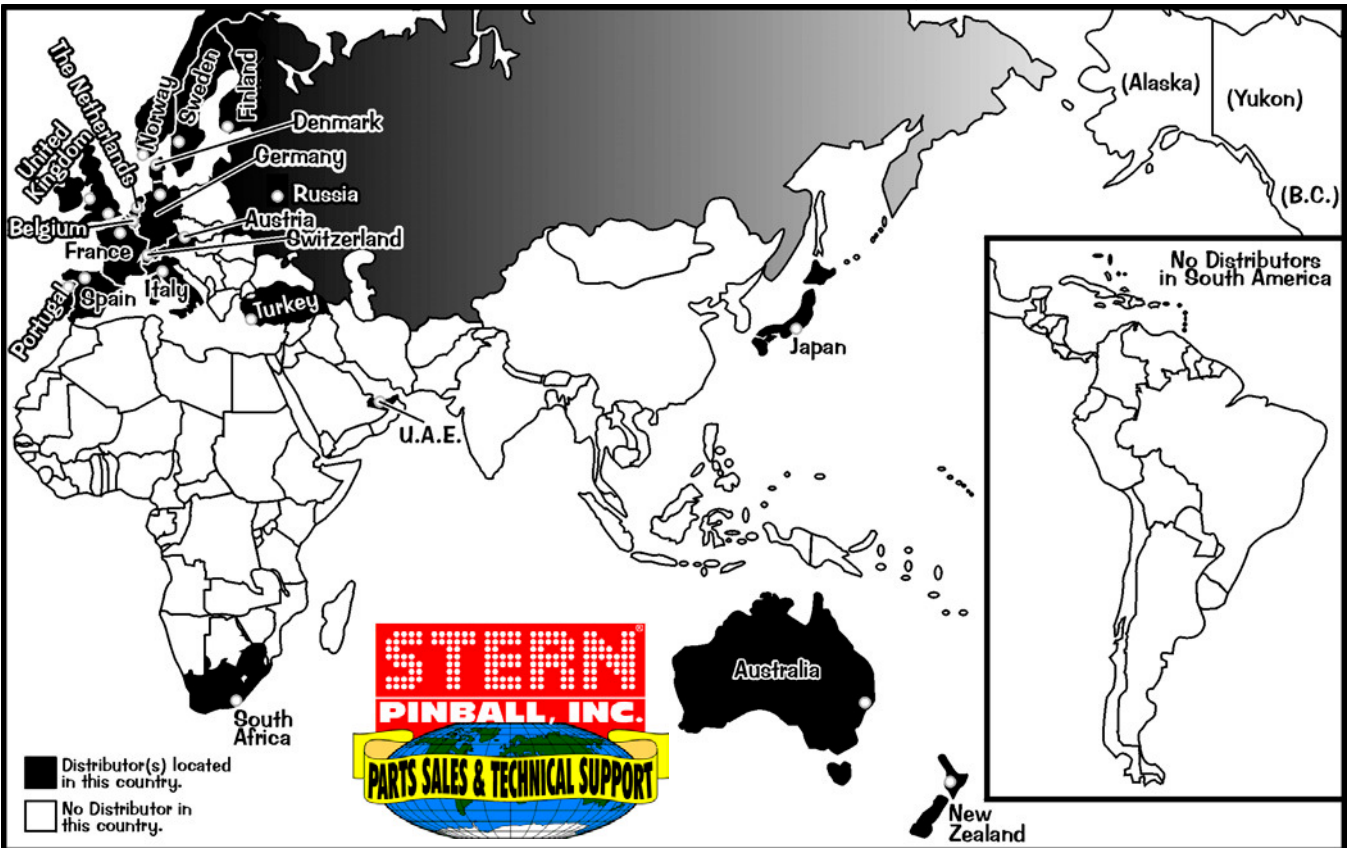

For *Parts & Service*, call your nearest Distributor. View the above maps & the directories on the next page to locate your closest Distributor in your state, province, or country. Distributors and phone numbers are subject to change. Call **Stern® Pinball, Inc. (Parts Sales & Technical Support)** with any questions or if your Distributor cannot help you: 1-800-542-5377 (in USA or Canada) or 1-708-786-5466. Visit us at [www.SternPinball.com](http://www.SternPinball.com) for current Distributor Information & other pinball needs.





# Domestic Pinball & Redemption Distributors Directory

<p><b>ALABAMA</b> Birmingham Vending Birmingham (1) 205-324-7526</p> <p><b>Franco Distributing</b> Montgomery (2) 334-834-3455</p> <p><b>ARIZONA</b> Betson West Phoenix 480-380-8857</p> <p><b>Mountain Coin</b> Phoenix 602-269-7596</p> <p><b>CALIFORNIA</b> Betson West Buena Park (1) 714-228-7500 So. San Francisco (2) 650-952-4220</p> <p><b>C.A. Robinson</b> Los Angeles (3) 323-735-3001</p> <p><b>COLORADO</b> Game Exchange of CO Denver 303-288-6500 (sales) 303-288-4300 (main)</p> <p><b>Mountain Coin</b> Denver 303-427-2133</p> <p><b>CONNECTICUT</b> TDM Distributing Williamantic 860-423-1403</p> <p><b>FLORIDA</b> Birmingham Vending Orlando (1) 407-425-1505</p> <p><b>Brady Distributing</b> Miami [Miramar] (2) 954-874-1100 Orlando (1) 407-872-1666</p> <p><b>GEORGIA</b> Greater Southern Dist. Smyrna 770-803-3040</p> <p><b>ILLINOIS</b> American Vending Sales Elk Grove Village (1) 847-439-9400</p> <p><b>Betson Midwest</b> Bensenville (2) 630-238-9400</p>	<p><b>INDIANA</b> Shaffer Distributing Indianapolis 317-899-2530</p> <p><b>IOWA</b> Greater America Dist. Johnston 515-278-4455</p> <p><b>Moss Distributing</b> Des Moines 515-266-6422</p> <p><b>KANSAS</b> United Dist., Inc. Wichita 316-263-6181</p> <p><b>LOUISIANA</b> AMA Distributors, Inc. Metairie (1) 504-835-3232</p> <p><b>New Orleans Novelty</b> New Orleans (2) 504-888-3500</p> <p><b>MARYLAND</b> Betson Enterprises Baltimore 410-646-4100</p> <p><b>Parts &amp; Service Only:</b> Weiner Distributing Baltimore 410-525-2600</p> <p><b>MASSACHUSETTS</b> Betson Ent. (NECO) Norwood (1) 781-769-9760</p> <p><b>Gekay Sales</b> Ludlow (2) 413-583-7700</p> <p><b>MICHIGAN</b> Shaffer Distributing Livonia (2) 734-432-1040</p> <p><b>MINNESOTA</b> Lieberman Companies Minneapolis (1) 800-879-0321 or 952-887-5299</p> <p><b>Moss Distributing</b> Bloomington (2) 952-881-8770</p>	<p><b>MISSOURI</b> Greater America Dist. Kansas City (1) 816-531-4300</p> <p><b>Moss Distributing</b> Kansas City (1) 816-231-6600</p> <p><b>Shaffer Distributing</b> St. Louis (2) 314-645-3393</p> <p><b>NEBRASKA</b> Central Distributing Omaha 402-493-5600</p> <p><b>Greater America Dist.</b> Omaha 402-553-2812</p> <p><b>NEVADA</b> Mountain Coin Las Vegas (1) 702-798-0900</p> <p><b>Reno Game Sales</b> Reno (2) 775-829-2080</p> <p><b>NEW JERSEY</b> Betson Enterprises Carlstadt (1) 201-438-1300</p> <p><b>Jack Guarnieri</b> Service Co., Inc. (Pinballsales.com) Lakewood (2) 800-473-5225 or 732-364-9900</p> <p><b>NEW MEXICO</b> Mountain Coin Albuquerque 505-345-7706</p> <p><b>NEW YORK</b> Betson Enterprises New Hyde Park (2) 516-354-4647 Syracuse (3) 315-437-2400</p> <p><b>Parts &amp; Service Only:</b> Bay Coin Richmond Hill (1) 718-291-5757</p>	<p><b>NORTH CAROLINA</b> Brady Distributing Charlotte (1) 704-357-6284</p> <p><b>Parts &amp; Service Only:</b> Operators Distributing Archdale (2) 336-884-5714</p> <p><b>OHIO</b> Shaffer Distributing Cincinnati (3) 800-282-0194 Columbus (1) 614-421-6800 Valley View (2) 216-447-1749</p> <p><b>OKLAHOMA</b> Galaxy Distributing Tulsa 918-835-1166</p> <p><b>OREGON</b> Mountain Coin Portland 503-234-5491</p> <p><b>Specialty Coin Products</b> Portland 800-987-4946 or 503-786-9200</p> <p><b>PENNSYLVANIA</b> Betson Enterprises King Of Prussia (1) 610-265-1155 Pittsburgh (2) 412-331-8703</p> <p><b>Superior Amusements</b> Wilkes-Barre (3) 570-824-9994</p> <p><b>SOUTH CAROLINA</b> Parts &amp; Service Only: Green Coin Myrtle Beach 843-626-1900</p> <p><b>TENNESSEE</b> Brady Distributing Memphis 901-345-7811</p> <p><b>Parts &amp; Service Only:</b> Green G.A.M.E.S. Memphis 901-353-1000</p>	<p><b>TEXAS</b> Amusement Distributors San Antonio (3) 210-225-3844</p> <p><b>Betson Texas</b> Dallas (1) 214-638-4900</p> <p><b>Commercial Music</b> Dallas (1) 214-741-6381</p> <p><b>Discount Arcade Games</b> Crowley (1) 817-297-0440</p> <p><b>H.A. Franz, &amp; Co.</b> Houston (2) 713-523-7366 San Antonio (3) 210-226-6322</p> <p><b>Master Sales</b> Corsicana (4) 903-874-4740</p> <p><b>UTAH</b> Mountain Coin Salt Lake City 801-262-5494</p> <p><b>Struve Distributing</b> Salt Lake City 801-328-1636</p> <p><b>WASHINGTON</b> Mountain Coin Auburn (Seattle) 253-736-6073</p> <p><b>WISCONSIN</b> Pioneer Sales &amp; Svc. Menomonee Falls (2) 262-781-1420</p> <p><b>Lieberman Companies</b> Menomonee Falls (2) 800-236-1880 or 262-703-4168</p>	<p style="text-align: center;"><b>CANADA</b></p> <p><b>ONTARIO</b> Starburst Coin Mach. Toronto 416-251-2122</p> <p><b>BRITISH COLUMBIA</b> Parts &amp; Service Only: Can. Coin Machine Burnaby (1) 604-420-4008</p> <p><b>Parts &amp; Service Only:</b> Pacific Vending Vancouver (2) 604-324-2164</p>
--	---	--	--	---	---

*Note: For states and Canadian Provinces which do not have Distributors, call the neighboring state or province with the city closest to you (indicated with a white dot). States or Provinces with more than 1 city containing a distributor are numbered. View the map on the previous page.*

*Note: From inside the US, use prefix 1-.*

**Note: Distributors are subject to change. Visit us at [www.SternPinball.com](http://www.SternPinball.com) for current Distributor Information.**

# International Distributors Directory

<p><b>AUSTRALIA</b> Amusement Mach. Dist. Alexandria +61 (2) 9700 9600</p> <p><b>AUSTRIA</b> Parts &amp; Service Only: R. Rupp Leibnitz +43 3452 86105</p> <p><b>BELGIUM</b> NAMUSCO Bruxelles +32 (0) 2 414 4596</p> <p><b>DENMARK</b> JK Automater A/S Thisted +45 97 92 09 25</p> <p><b>ENGLAND</b> see UNITED KINGDOM</p> <p><b>FINLAND</b> Pelika net Oy Vantaa +358 (0) 9 290 450</p>	<p><b>FRANCE</b> Avranches Automatic Ducey +33 23 389 6162</p> <p><b>SFA</b> Paris +33 15 326 8080</p> <p><b>GERMANY</b> ADP Gauselmann Espelkamp +49 5741 27 33 84 Bergmann Int'l Gaming Rellingen +49 4101 3 02 40 Witten +49 2302 28 25 40 Merkur Gaming GmbH Luebbecke +49 5772 4 94 22</p> <p><b>HOLLAND</b> see THE NETHERLANDS</p>	<p><b>ITALY (RSM)</b> Tecnoplay S.A. San Marino +39 549 901 508</p> <p><b>JAPAN</b> HIC, Inc. Chiba-Ken +04 7176 4040</p> <p><b>THE NETHERLANDS</b> JVH Gaming Products Tilburg +31 13 595 3200</p> <p><b>NEW ZEALAND</b> Coin Cascade Ltd. Christchurch +643 338 1411</p> <p><b>Parts &amp; Service Only:</b> Amco Machine Supplies Auckland +64 9846 7606</p>	<p><b>NORWAY</b> Parts for Pinballs Sandefjord +47 9242 1402</p> <p><b>Vendomatic AS</b> Oslo +47 2 291 8383</p> <p><b>PORTUGAL</b> Jacinto &amp; Martins, S.A. Belas +35 1214 3256 24 or +35 1214 3256 38</p> <p><b>RUSSIA</b> Kalmancor Enterprise Ltd Moscow +0 95 124 5601 or +0 95 124 5613</p> <p><b>O.D.A. Game Machines</b> Moscow +0 95 219 2949 or +0 95 219 8917</p>	<p><b>SOUTH AFRICA</b> K &amp; W Amusements Port Elizabeth +27 41 484 3344 or +27 41 484 2940</p> <p><b>SPAIN</b> Comercial Cocomatic Coslada (Madrid) +34 91 671 6980</p> <p><b>SWEDEN</b> Bjuvia Fritid AB Bjuv +46 4238 6900</p> <p><b>SWITZERLAND</b> Novomat, A.G. Harkingon +41 62 388 8961</p> <p><b>TAIWAN, R.O.C.</b> SEC Taichung +886 4 229 10646</p>	<p><b>TURKEY</b> Balo Marmaris +0 252 413 83 35</p> <p><b>UNITED ARAB EMIRATES</b> Warehouse of Games Dubai +971 4 883 5880</p> <p><b>UNITED KINGDOM</b> Electrocoin London, England +44 208 965 2055</p> <p><b>Parts &amp; Service Only:</b> Electrocoin Aftersales Cardiff, S. Glamorgan +44 292 045 0345</p> <p><i>Note: From inside the US, use prefix 011-.</i></p>
---	---	---	---	--	--



**Find-It-In-Front:  
Dr. Pinball**



# POWER REQUIREMENTS



This game **must be connected to a properly grounded outlet to reduce shock hazard** & insure proper game operation. See *Sec. 5, Schematics & Troubleshooting, Chp. 3, Cabinet Wiring (Transformer Power Wiring)*, for transformer connections required for **Normal, High, and Low Line** conditions.



Normal Line:		110v AC - 125v AC @ 60Hz	
<b>Domestic</b> use an 8AMP 250v Slo-Blo Fuse.	<b>AVG OPERATION</b>	CURRENT: <b>2.8AMP</b> WATTAGE: <b>329w</b>	<b>MAX OPERATION</b> CURRENT: <b>8AMP</b> WATTAGE: <b>940w</b>
	<b>High Line:</b> use 2x 5AMP 250v Slo-Blo Fuses. (*England & Hong Kong use an 8AMP 250v S/B Fuse.)		218v AC - 240v AC @ 50Hz <b>AVG OPERATION</b> CURRENT: <b>1.8AMP</b> WATTAGE: <b>412w</b>
<b>Export</b> use 2x 5AMP 250v Slo-Blo Fuses. (*England & Hong Kong use an 8AMP 250v S/B Fuse.)	<b>AVG OPERATION</b>	CURRENT: <b>1.8AMP</b> WATTAGE: <b>412w</b>	<b>MAX OPERATION</b> CURRENT: <b>5AMP</b>   <b>8AMP*</b> WATTAGE: <b>1145w</b>   <b>1832w*</b>
	<b>Low Line:</b> use an 8AMP 250v Slo-Blo Fuse.		95v AC - 108v AC @ 50Hz / 60Hz <b>AVG OPERATION</b> CURRENT: <b>2.6AMP</b> WATTAGE: <b>264w</b>

England & Hong Kong use an 8A Fuse.

## TRANSPORTATION

## GAME DIMENSIONS

### BEFORE TRANSPORTING



To reduce the possibility of damage, observe **ALL** precautions whenever transporting the game.

**Read & follow Section 1, Chapter 1, Pinball Game Set-Up Procedures, and How to Secure the Backbox for Transporting.** Remove the legs and secure the game within the transporting vehicle.

**SAVE AND RETAIN ALL PRINTED INFORMATION INSIDE THE CABINET!**

**Shipping Box Dimensions**

Height 56" Width 31"  
 Depth 31"  
 Approx. Unboxed Weight: 270lbs. (+/- 10)  
 Boxed Weight: Wt. 290lbs. (+/- 5)

**CAUTION**

At least 2 people are required to move and maneuver this game. Use proper moving equipment & extreme care while handling!

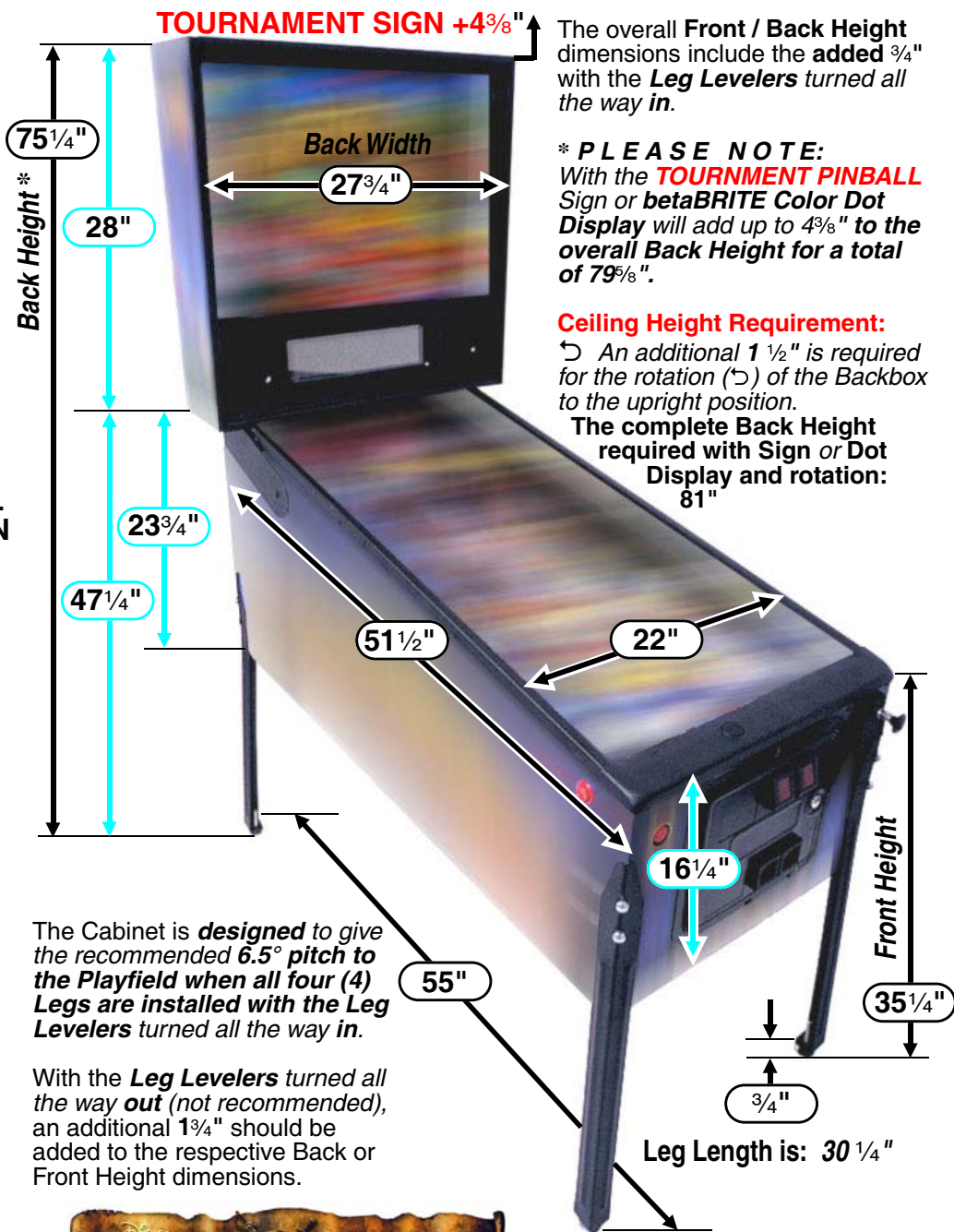

Find-It-In-Front:  
 Dr. Pinball

# Disney PIRATES of the CARIBBEAN Pinball

**How To Update Your Game Code for the New S.A.M. System ..... Inside Front**

**Find-It-In-Front: Dr. Pinball ..... DR. 1 – 16**

- ▶ For Proper Operation of this Pinball Game, (4) Pinballs must be installed in the Ball Trough! // Backbox Fuses, Cabinet Fuses, Playfield Fuses and Cabinet Switches .....DR. 1
- ▶ Find-It-In-Front: Dr. Pinball Section Explained .....DR. 2
  - ▷ Service Switch X4 Set Overview ▷ Functions in Game or Attract Mode ▷ Functions in the Service Menu
- ▶ Diagnostic Aids .....DR. 3
- ▶ CPU Dip Switch Settings .....DR. 3
- ▶ Switch Matrix Grid (#1 – #64) and Dedicated Switches (D-1 – D-32).....DR. 4
- ▶ Switch Locations .....DR. 5
- ▶ Lamp Matrix Grid (#1 – #80) .....DR. 6
- ▶ Lamp Locations .....DR. 7
- ▶ Coils Detailed Chart Table .....DR. 8
- ▶ Coil & Flash Lamp Locations .....DR. 9
- ▶ Go To Adjustments Menu: Standard Adjustments [ #1 – #63 ].....DR. 10
- ▶ Go To Adjustments Menu: Feature Adjustments [ #1 – #14 ] .....DR. 11
- ▶ Go To Audits Menu: Earnings Audits [ #1 – #13 ] / Standard Audits [ #1 – #59 ] .....DR. 12
- ▶ Go To Audits Menu: Feature Audits [ #1 – #34 ] .....DR. 13
- ▶ Domestic Pinball & Redemption Distributors Map // International Distributors Map.....DR. 14
- ▶ Domestic Pinball & Redemption Distributors Directory // International Distributors Directory.....DR. 15
- ▶ Power Requirements // Transportation // Game Dimensions .....DR. 16

**Sections 1-5, General Table of Contents .....i – ii**

**Section 1, Chapter 1 of 1, After Set-Up .....1 – 4**

- ▶ Pinball Game Set-Up Procedures .....1
  - ▷ Backbox (backglass removed): ▷ Playfield (glass removed): ▷ With the Coin Door Open:
- ▶ Pinball Game Set-Up Future Reference..... 1-3
- ▶ How to Secure the Backbox ... // Leg Leveler Adjustment // Easy Access Service System - 2 Positions.....4

**Section 2, Chapter 1 of 1, Game Operation & Features .....5 – 6**

- ▶ Start of Game Features .....5
  - ▷ Starting a Normal Game ▷ Starting Team Play (Doubles!) ▷ Starting Tournament Play
- ▶ During Game Features .....5
  - ▷ Feature Mode & Combination Shots ▷ Multiball ▷ Replay Feature
- ▶ End of Game Features .....5
  - ▷ Game Endings ▷ Match Feature ▷ Entering Initials/Name
- ▶ Auto Percentaging .....6
- ▶ Instruction Card.....6

**Section 3, Chapter 1 of 6, Service Menu System ..... 7 – 12**

- ▶ Table of Contents for Section 3.....7

**Section 3, Chapter 2 of 6, Go To Diagnostics Menu .....13 – 20**

**Section 3, Chapter 3 of 6, Go To Audits Menu .....21 – 24**

**Section 3, Chapter 4 of 6, Go To Adjustments Menu .....25 – 34**

**Section 3, Chapter 5 of 6, Go To Utilities Menu .....35 – 40**

**Section 3, Chapter 6 of 6, Go To Tournament Menu.....41 – 42**

**Section 4, Chapter 1 of 2, Parts Identification & Location (The Pink Pages) .....43 – 64**

- ▶ Table of Contents for Section 4, Chapter 1 .....43

**Section 4, Chapter 2 of 2, Drawings for Major Assemblies & Ramps (The Blue Pages) .....65 – 94**

- ▶ Table of Contents for Section 4, Chapter 2 .....65

**Section 5, Chapter 1 of 4, Backbox Wiring.....95 – 98**

- ▶ Table of Contents for Section 5.....95

**Section 5, Chapter 2 of 4, Playfield Wiring.....99 – 104**

**Section 5, Chapter 3 of 4, Cabinet and Coin Door Wiring .....105 – 108**

**Section 5, Chapter 4 of 4, Printed Circuit Boards (PCBs) ..... 109 – 138**

**Appendixes A - J, Table of Contents ..... End of Manual**

- ▶ Stern Pinball, Inc. Limited Warranty // Cautions, Warnings & Notices ..... last page





# GLOSSARY OF TERMS

- A** Followed after a number means "Amp." or Ampage in an expression relating to an electrical object. (e.g. **8A**).
- AC** (Acronym) **Alternating Current**.
- Adj.** (Abbreviation) Adjustment(s).
- Assy.** (Abbreviation) Assembly.
- Au.** (Abbreviation) Audit(s).
- Bd.** (Abbreviation) Board.
- BOT** (Abbreviation) Bottom.
- Brkt.** (Abbreviation) Bracket.
- Bridge Rectifier** A configuration of a diode that allows current to flow in one direction producing both positive and negative pulsating DC Voltages.
- Color Coding** See Appendix H or I, Plastic Part Color Chart or Section 4, Chapter 1, Playfield - Plastic Posts & Spacers.
- Combination (Combo) [Shot]** Any variable pinball shot(s) made successively.
- Conn.** (Abbreviation) Connector.
- CMOS** Short for COSMOS (Complementary Symmetry M.O.S.); Complementary Metal-Oxide Semi-Conductor.
- CN** (Abbreviation) Connector (e.g. **CN5-P3**).
- CT** (Abbreviation) Center.
- DC** (Abbreviation) Direct Current.
- DT** (Abbreviation) Drop Target(s).
- DOTS** (Acronym) **Diode On Terminal Strip**.
- EB** (Abbreviation) Extra Ball.
- Eject** Playfield surface device to kick ball back into play; Saucer.
- EPROM** (Acronym) **Erasable Programmable Read Only Memory**. Can be erased using UV Light and re-programmed.
- e.g.** (Abbreviation) Latin- Exempla gratia. For Example.
- EOS** (Acronym) **End-Of-Stroke** (i.e. Switch for flipper).
- F** (Abbreviation) Fuse (i.e. **F23**).
- GA-Turn** Gauge & Turn describing the windings on a coil (e.g. **23-800**, **23** is the gauge of wire and **800** is the amount of windings).
- G.I.** (Abbreviation) General Illumination (Lamps).
- HWH** (Abbreviation) Hex Washer Head.
- IC** (Acronym) **Integrated Circuit** (As in after 24-Pin IC).
- ID or I.D.** (Acronym) **Inside Dimension**.
- i.e.** (Abbreviation) Latin- Id est. That is.
- IO or I/O** (Abbreviation) Input / Output (e.g. I/O Power Driver Bd.)
- LT, Lt. or L.** (Abbreviation) Left.
- Laser Kick** A coil/plunger used above the playfield to kick pinball back into play.
- LED** (Acronym) **Light Emitting Diode**.
- Loop [Shot]** Continuously up a ramp and back to the flipper.
- Lwr.** (Abbreviation) Lower.
- Orbit [Shot]** From the left or right flipper around the back rail of the playfield back to the flipper.
- MB** (Abbreviation) Magnet Board.
- M-BALL or MBALL** (Abbreviation) Multiball™ More than 1 ball in game play.
- MID** (Abbreviation) Middle
- Non-Reflexive** See Reflexive.
- No. or N° or #** (Abbreviation) Number
- NPF** (Acronym) **No Problem Found**.
- N.C. or NC** (Abbreviation) Normally Closed.
- N.O. or NO** (Abbreviation) Normally Open.
- NS** (Abbreviation) Not Stuffed. (Use in Part Listings, Sec. 5)
- OD or O.D.** (Abbreviation) Outside Dimension.
- P** (Abbreviation) Pin (e.g. **CN5-P3**).
- PCB** (Acronym) **Printed Circuit Board**
- P/F** (Abbreviation) Playfield.
- PIA LED** (Acronym) **Peripheral Interface Adapter Light Emitting Diode**. This is a diagnostic LED on the CPU; it should not be lit during normal operation of a pinball game.
- Plumb Bob Tilt** Weight on Tilt Assembly.
- PPH** (Abbreviation) Phillips Pan Head.
- Pop(s)** Another term for Turbo Bumper(s).
- PPB** (Acronym) Playfield Power Board ("Popcorn-Popping Bd.").
- PREV** (Abbreviation) Previous.
- PSB** (Abbreviation) Power Supply Board
- RAM** (Acronym) **Random Access Memory**. **RAM can** store input instructions and supply output information.
- Reflexive/Non-Reflexive Reflexive**—Solenoid Drive Transistor is enabled directly by a switch closure on the (Relating to CPU Boards) solenoid assembly (Ver. 1/2).
- Non-Reflexive**—Solenoid Drive Transistor is enabled by the CPU after reading a switch closure in the Switch Matrix (Ver. 3). Also note: All CPU Boards are backwards compatible (e.g. Jurassic Park/Ver. 3 to Time Machine/ Ver. 2). Swapping a Ver. 2 Board to a Ver. 3 is not possible due to the special solenoids section (i.e. Slingshots, Turbo Bumpers, etc.) changing from **REFLEXIVE** to **NON-REFLEXIVE** on Ver. 3 Boards.
- Relay** An automatic switch operated by current in a coil.
- ROM** (Acronym) **Read Only Memory**. **ROM cannot** store input instructions but can supply output information. **ROM can be programmed only once**.
- RMA** (Abbreviation) Return Merchandise Authorization Number
- RT, Rt. or R.** (Abbreviation) Right; ("**R**" at the end of Target Assy. Part N° signifies Target Insert is Reversed.)
- RO** (Abbreviation) Rollover (switches).
- Saucer** See Eject.
- Scoop** A hole into the playfield. A metal scoop is in place to guide the ball into the kick-back under the playfield.
- Slam Tilt** A switch which closes when the game is slammed into or the Coin Door is slammed shut. Depending on adjustable settings, will cancel game in play when the number of closures required is achieved.
- SMB** (Abbreviation) Shaker Motor Board.
- Solenoid** A coil used for Electro Magnetic devices such as relays, flippers, slingshots, etc.
- SSFB** (Abbreviation) Solid State Flipper Board.
- STEP** Refers to the service switches on the coin door.
- Sub-Assy.** (Abbreviation) Sub-Assembly.
- S-U or S/U** (Abbreviation) Stand-Up ( targets).
- TM** (Abbreviation) Trademark
- Transfer [Shot]** Maneuvering the ball in play from one flipper to the other. With flipper in the up position and the ball cradled by that flipper one would activate the flipper button in a quick repetitive manner to bounce the ball to the other side. Skilled players can rebound the ball off the slingshot.
- Tri-Ball** Three balls in play.
- TTL** (Abbreviation) Transistor-Transistor Logic
- Upr.** (Abbreviation) Upper.
- V or v** (Abbreviation) Volt(s).
- Ver.** (Abbreviation) Version.
- VUK** (Acronym) **Vertical Up-Kicker** (Super or Standard).
- X** (Abbreviation) "Times" A multiplier; also used in dimensions.
- X-Ball** An undetermined number of ball(s) during game play.
- Zener Diode** A semi-conductor diode used for voltage regulation. Application depends on reverse break-down voltage.
- "-00B"** "B" at the end of Coil Part Numbers signifies that the diode is attached to the bottom of the lug.
- "-00T"** "T" at the end of Coil Part Numbers signifies that the diode is attached to the top of the lug (the side nearest the coil-winding).

# STERN® PINBALL, INC. LIMITED WARRANTY

STERN® PINBALL, INC., ("SELLER") WARRANTS ONLY TO THE INITIAL PURCHASER OF ITS PRODUCTS THAT THE ITEMS LISTED BELOW ARE FREE FROM DEFECTS IN MATERIAL AND WORKMANSHIP UNDER NORMAL USE AND SERVICE FOR THE **WARRANTY PERIOD SPECIFIED**:

**PRINTED CIRCUIT BOARDS (GAME LOGIC): 2 MONTHS**  
**DOT MATRIX DISPLAY BOARDS: 9 MONTHS**

NO OTHER PARTS OF SELLER'S PRODUCT ARE WARRANTED.

WARRANTY PERIODS ARE EFFECTIVE FROM THE INITIAL DATE OF SHIPMENT FROM SELLER TO ITS AUTHORIZED DISTRIBUTORS.

SELLER'S SOLE LIABILITY SHALL BE, AT ITS OPTION, TO REPAIR OR REPLACE PRODUCTS WHICH ARE RETURNED TO SELLER DURING THE WARRANTY PERIODS SPECIFIED, PROVIDED:

1. SELLER IS NOTIFIED PROMPTLY UPON DISCOVERY BY PURCHASER THAT STATED PRODUCTS ARE DEFECTIVE.
2. SUCH PRODUCTS ARE PROPERLY PACKAGED AND THEN RETURNED FREIGHT PREPAID, TO SELLER'S PLANT.

THIS WARRANTY DOES NOT APPLY TO ANY PARTS DAMAGED DURING SHIPMENT AND/OR DUE TO IMPROPER HANDLING, OR DUE TO IMPROPER INSTALLATION OR USAGE, OR ALTERATION. IN NO EVENT SHALL THE SELLER BE LIABLE FOR ANY ANTICIPATED PROFITS, LOSS OF PROFITS, LOSS OF USE, ACCIDENTAL OR CONSEQUENTIAL DAMAGES OR ANY OTHER LOSSES INCURRED BY THE CUSTOMER IN CONNECTION WITH THE PURCHASE OF A STERN® PINBALL, INC. PRODUCT.

## WARRANTY DISCLAIMER

EXCEPT AS SPECIFICALLY PROVIDED IN A WRITTEN CONTRACT BETWEEN SELLER AND PURCHASER, THERE ARE NO OTHER WARRANTIES, EXPRESS OR IMPLIED, INCLUDING ANY IMPLIED WARRANTIES OF MERCHANTABILITY OR FITNESS FOR A PARTICULAR PURPOSE.

## CAUTIONS, WARNINGS & NOTICES

### Caution

 FOR SAFETY AND RELIABILITY, SUBSTITUTE PARTS AND EQUIPMENT MODIFICATIONS ARE NOT RECOMMENDED (AND MAY VOID ANY WARRANTIES). USE OF NON-STERN® PINBALL INC. PARTS OR MODIFICATIONS OF GAME CIRCUITRY, MAY ADVERSELY AFFECT GAME PLAY, OR MAY CAUSE INJURIES. TRANSPORT PINBALL GAMES WITH HINGED BACKBOX IN THE DOWN POSITION ONLY! ALWAYS TAKE GREAT CARE WHEN SERVICING ANY GAME. ALWAYS READ THE SERVICE MANUAL BEFORE REPLACING OR SERVICING COMPONENTS. **SUBSTITUTIONS OF PARTS OR EQUIPMENT MODIFICATIONS** MAY VOID FCC TYPE ACCEPTANCE.



**Always Disconnect The Line Voltage Before Servicing. Some Parts May Still Hold Current When Unplugged.**

### Warning

 THIS EQUIPMENT GENERATES, USES, AND CAN RADIATE RADIO FREQUENCY ENERGY, AND IF NOT INSTALLED AND USED IN ACCORDANCE WITH THE INSTRUCTIONS MANUAL, MAY CAUSE INTERFERENCE TO RADIO COMMUNICATIONS. IT HAS BEEN TESTED AND FOUND TO COMPLY WITH THE LIMITS FOR A CLASS A COMPUTING DEVICE PURSUANT TO SUBPART J OF PART 15 OF FCC RULES, WHICH ARE DESIGNED TO PROVIDE REASONABLE PROTECTION AGAINST SUCH INTERFERENCE WHEN OPERATED IN A COMMERCIAL ENVIRONMENT. OPERATION OF THIS EQUIPMENT IN A RESIDENTIAL AREA IS LIKELY TO CAUSE INTERFERENCE IN WHICH CASE THE USER AT HIS OWN EXPENSE WILL BE REQUIRED TO TAKE WHATEVER MEASURES MAY BE REQUIRED TO CORRECT THE INTERFERENCE.

RF INTERFERENCE NOTICE, CABLE HARNESS PLACEMENTS AND GROUND STRAP ROUTING ON THIS GAME HAVE BEEN DESIGNED TO KEEP RF RADIATION AND CONDUCTION WITHIN LEVELS ACCEPTED BY THE FCC RULES. TO MAINTAIN THESE LEVELS, REPOSITION HARNESSES AND RECONNECT GROUND STRAPS TO THEIR ORIGINAL PLACEMENTS, IF THEY BECOME DISCONNECTED DURING MAINTENANCE.

### Notices

THIS DOCUMENT AND THE DATA DISCLOSED HEREIN OR HERewith IS NOT TO BE REPRODUCED (EXCEPT WHERE NOTED), USED OR OTHERWISE DISCLOSED IN WHOLE OR IN PART TO ANYONE WITHOUT WRITTEN CONSENT OF STERN® PINBALL, INC. **WARNING:** PRODUCTS IN THIS MANUAL, THE COMPANY NAME AND DEVICES AND THE DESIGN OF THE MANUAL ITSELF, ARE PROTECTED BY FEDERAL PATENTS (AND PATENTS PENDING), DESIGN REGISTRATIONS, TRADEMARKS AND COPYRIGHTS. ACTION WILL BE TAKEN IN THE EVENT OF INFRINGEMENT OR IMITATION. THE RIGHT IS RESERVED TO CHANGE SPECIFICATIONS WITHOUT PRIOR NOTICE.

© 2006 Manufactured by Stern® Pinball, Inc.  
Icon Designs, ToPS™ Logo, Bump N' Win™ Logo & all  
related indicia are trademarks of Stern® Pinball, Inc.  
All Rights Reserved. Made in the USA.

"Multiball" is a registered trademark of Williams Electronics  
Games, Inc. Used by permission.

PCB Schematics (Section 5, Chapter 4) by CES  
(Creative Electronics & Software, Inc.) © 1995.



Disney's Pirates of the Caribbean © Disney // Music Credits: Yo Ho (A Pirate's Life for Me) Words by Xavier Atencio and  
Music by George Bruns © 1967 Walt Disney Music Company (ASCAP). Copyright renewed. All Rights Reserved.



Copyright © 1998 BETA-BRITE and logo  
are trademarks of Adaptive Micro Systems,  
Inc. registered in the United States Patent  
and Trademark Office. All Rights Reserved.



TORTUGA  
PORT ROYAL

PARLAYS

50¢ = [ball icon] x1  
SUPER VALUE  
\$2.00 = [ball icon] x5

Play like guidelines  
MULTIBALL  
Hit the ship several times to sink it. This starts Parlay with the  
Prize. When the Kraken several times to hit a  
EXTRA BALL  
Collect 5 coins and Light Four Ball  
Defeat the Kraken and collect the JACK Award  
Then collect Light Four Ball from the Compass  
SPECIAL  
Defeat Davy Jones and collect the Super Jackpot from Heart  
Multiball! Then collect Light Special from the Compass!

THUNDER  
START

▼ U.S. ▼  
Customary  
Inch Ruler

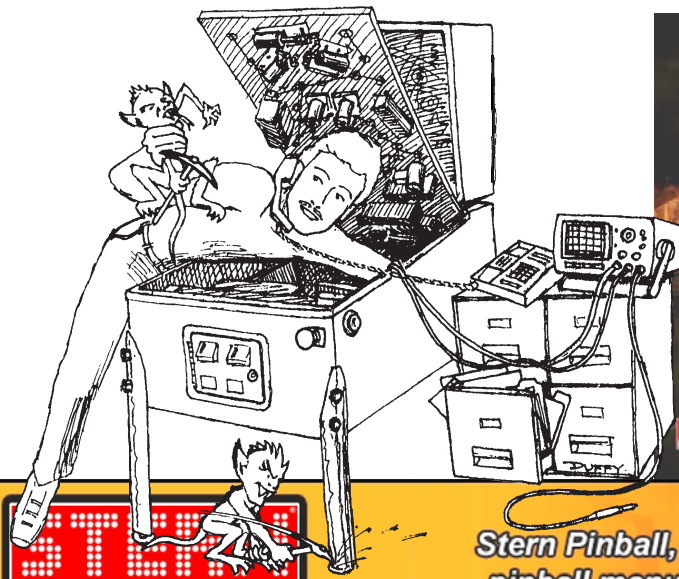

**Stern Pinball, Inc. is the only coin-op  
pinball manufacturer on the planet!**

2020 Janice Avenue  
Melrose Park, IL 60160  
phone: 708.345.7700  
fax: 708.345.7813  
info@sternpinball.com

Tech. Support  
& Parts Sales

Distributors

Pinball Links

Stern Info

Tournaments

Tour

Game Archive

Contact Us

Home

### Technical Support & Parts Sales

[2002, 2003](#) (2-Disc Set) [2004](#) (2-Disc Set) & [2005](#) (2-Disc Set) CD-GAMES are now available!  
Click year for more info!

We at STERN Pinball continuously strive to provide our distributors, operators, and game owners with the best technical support possible. We, therefore, have provided you with the service options listed below. If your game requires parts and/or service, please contact your nearest STERN Pinball distributor (See our [Distribution List](#)). For any additional assistance, contact our technical service staff at 800-KICKERS (800-542-5377) or by e-mail at [parts.service@sternpinball.com](mailto:parts.service@sternpinball.com).

If your STERN Pinball is in need of repair, please contact your nearest [STERN Distributor](#).

#### Pinball Game Parts

- Offering Service Game Manual excerpts: Parts Identification & Location (**The Pink Pages**), Drawings for Major Assemblies & Ramps (**The Blue Pages**) and Appendixes A-J (*updated with each game*)

#### Service Bulletins

- Detailing Technical Information, Tips, FYIs, Notices and Updates

#### GAME Code Library

- Offering game code for all Data East®, Sega™ and STERN® Pinballs (*EPROM Programmer required*)

#### Schematics, Theory of Operation and Troubleshooting Tips

- Drawings on the White Star Board System™

#### Coinage Cards

- Offering a range of Coinage Cards for download
- Country Setting, Pricing Scheme, Dip Switch Setting (*opens a pop-up window*)
- [Custom Pricing Demonstration](#) (for S.A.M. System)

#### Tricks & Tips

- Pinball Machine Foam Cushion Packing
- 1st Time Pinball Set-Up & Preventative Maintenance
- Pinball Location Maintenance
- How to Update Your Game Code (S.A.M. System)

#### Track Your Order Via UPS

#### NTE Semi-Conductor Cross Reference

#### Radio Shack Component Catalogue



### Metric Conversion

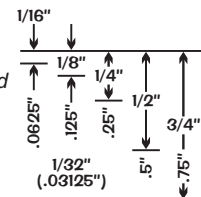

1" = 2.54 cm or 25.4 mm  
1 cm = .3937"  
1 mm = .03937"

For metric, multiply the inch value by the metric value:

example: 5" X 2.54 cm = 12.7 cm or 127 mm

For US, multiply the metric value by the inch value:

example: 13 cm X .3937" = 5.1181"

# 1 - 800 - 5 KICKERS

Visit our website [www.sternpinball.com](http://www.sternpinball.com) for Pinball & Redemption game information!

Click  to view, print or download all of the above!

**HELP US, HELP YOU!** If you have any suggestions, questions, need technical advice, find errors or have comments, contact us through our website or call!

This Game Service Manual and all other documents relating to this product, playfield components, features, rules, programming and operation are subject to change without notice (Service Bulletins, if applicable, available through our website).

 Games shipped factory direct to Europe from Stern Pinball, Inc. are CE approved and will have an "E" prefix attached to the Serial Number.





# After Set-Up

## Pinball Game Set-Up Procedures

...after reading the Pinball Game Set-Up Instruction Sheet (SPI Part N<sup>o</sup> 755-5310-00) included with your New Pinball Game, continue with the below procedures:

### Backbox (backglass removed):

1. Check all connectors for loose wire terminations. Reseat any loose wire by pushing in on the terminal. **Push on all** plugged in connectors for the CPU/Sound, I/O Power Driver and the Display Power Supply Boards (check that they are properly seated). Ensure the Fluorescent Light Tube is seated correctly. Check that all fuses are seated properly (fuses on the I/O Bd. have **Red LED** Status indicators). Reinstall backglass, lock the Backbox and secure its' keys back inside the Coin Door.

### Playfield (glass removed):

2. Remove all shipping tie downs, shipping blocks, packing foam, etc., if present. **READ ALL PRINTED INFORMATION!** Shipping Instructions and/or Decals describe warnings, cautions, and/or important information specific to the game. **SAVE ALL IN CABINET!**

If pinballs were already installed into the Ball Trough (under the arch), remove them before performing the following step. **\*\*\*Pinballs can fall out and away from the playfield\*\*\***

3. Raise the playfield and rest it against the Backbox. See the illustration "Easy Access Service System - 2 Positions" on Page 4.

4. Visually inspect all cabinet cables and connector terminations; ensure no wires or cables are pinched and that cable harnesses are not pulled tight.

5. Make sure the proper amount of pinballs are installed (decals on the lock down assembly and the inside manual cover describe how many pinballs are needed).

6. Lower the playfield and ensure game is **level side-to-side** by adjusting Leg Levelers, if required. See the illustration "Leg Leveler Adjustment" on Page 4. Start with the Leg Levelers turned all the way in (1.25" from floor to bottom of leg), depending on the condition of the floor, adjust the Leg Levelers as required until the **game pitch is 6.5°**, determined by the Bubble Level.

**USE THE BUBBLE LEVEL ON THE WOOD RAIL (LOWER RIGHT) TO DETERMINE IF LEVEL IS ACHIEVED. BUBBLE SHOULD APPEAR BETWEEN THE 2 BLACK LINES. SEE PAGE 4 FOR AN ILLUSTRATION.**

The playfield incline affects difficulty of play. Use the recommended incline; Game difficulty is best varied using game adjustments.

### With the Coin Door Open:

7. If desired, perform any self tests at this time (see Section 3, Chapter 1, **Service Menu Introduction**, and Chapter 2, **GO TO DIAGNOSTICS MENU**, for information on how to enter "Begin Play Test" and "Game Name Test" Menus, if any, to test components on the game).

8. If desired, adjust **Game Pricing, Standard and/or Custom** (see Section 3, Chapter 4, **GO TO ADJUSTMENTS MENU** and Section 3, Chapter 5, **GO TO INSTALLS MENU** to adjust **Game Difficulty, 3- or 5-Ball Play, Competition or Home Settings, Novelty, Add-A-Ball, etc.**)

### PINBALL GAME SET-UP

CAUTION: At least 2 people are required to move and maneuver game. Use proper moving equipment & extreme care while handling. Pinball game is 200lbs (+/- 10). Refer to Game Manual for Future Game Set-Up Procedures (Sec. 1, Chap. 1) and other important information!

TOOLS REQUIRED: 5/8" Socket Wrench & Utility Knife

NOTE: KEYS are tied to the Shooter Rod\* (if equipped) or tied to the Playfield Glass if equipped with Auto Plunger Button. Remove keys. One (1) set of keys resides in the Coin Door; the other set is used to unlock the Back Glass to gain access to the White Star Board System.

ALWAYS STORE THE MANUAL & INFORMATION SHEETS INSIDE THE CABINET WHEN NOT USING.

SPI Part N<sup>o</sup> 755-5310-00

Per CE: "The appliance has to be placed in a horizontal position." This appliance is not to be cleaned by a Water Jet.



After Set-Up



# Pinball Game Set-Up Future Reference

Open up the Printable Version in both 8-1/2 X 11 & 11 X 17.

**CAUTION:** At least 2 people are required to move and maneuver game.

Use proper moving equipment & extreme care while handling. Pinball game is 260lbs (+/- 10).

Refer to Game Manual for further Game Set-Up Procedures (Sec. 1, Chp. 1) and other important information!

**TOOLS REQUIRED:** 5/8" Socket Wrench & Utility Knife

Sec. 1: After Set-Up



1. Before unpacking box, lay the box flat on its side with "TRUCK THIS SIDE ONLY" facing the floor.



2. Slide game out using the **Black Nylon Strapping** as a handle.

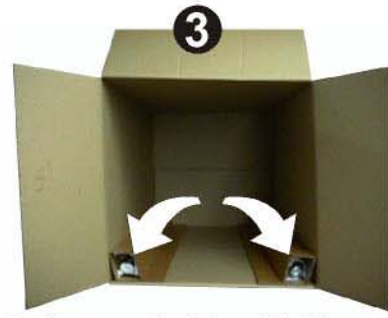

3. Remove the **Four (4) Identical Legs with Levelers** from the carton and set aside. (**SAVE!** all packing materials and information sheets related to this pinball until Set-Up is complete.)

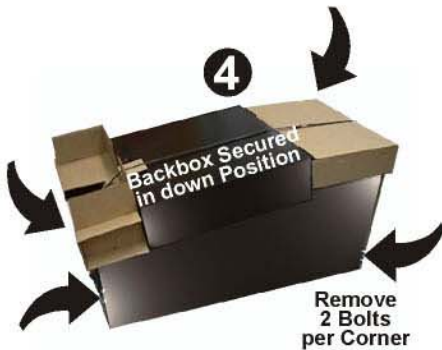

4. At this point **DO NOT CUT STRAPPING** (You want to keep the Backbox secured in the down position). Loosen and remove the 8 Leg Bolts (use 5/8" Socket Wrench) and set aside.



5. Lift game into an **UPRIGHT POSITION** (Coin Door Facing Up).



6. Install **FRONT LEGS** using the bolts removed from **Step 4**. Secure tightly. **Take care not to scratch the Black Finish on any of the Legs.**



7. Carefully set the game down on the **FRONT LEGS**. Care should be taken...Game is heavy, two (2) people are recommended for this and the following step.



8. Using supports or two (2) people, prop the rear of the cabinet up and install **REAR LEGS**. Secure tightly.



9. Cut **BLACK NYLON STRAPPING**. **CAUTION:** Strapping will **SNAP**, protect your eyes! Use extreme care when using a utility knife or scissors.

# Pinball Game Set-Up Future Reference Continued

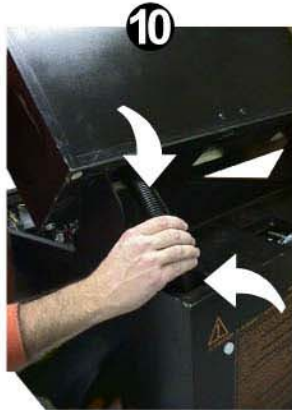

10. Lift the Backbox into the **UPRIGHT POSITION** (Ensure the cables do not get pinched).



11. After the **BACKBOX** is in the **UPRIGHT POSITION**, locate the **5/16" HEX KEY**. While inserted, rotate **KEY** with a **3/4** turn until latched & locked.



12. The next step you will remove the **PLAYFIELD GLASS & BACK GLASS** to access the inside of the cabinet & Backbox.

**NOTE:** KEYS are tied to the Shooter Rod\* (if equipped) or taped to the Playfield Glass (if equipped with Auto Plunger Button). Remove keys. One (1) set of keys opens the Coin Door, the other set is used to unlock the Back Glass to gain access to the White Star Board System.

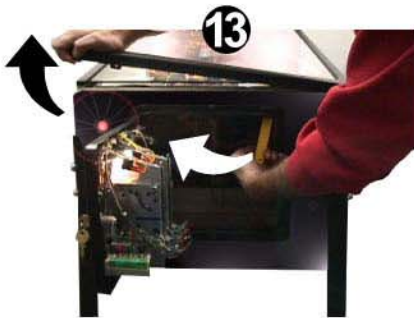

13. Open the Coin Door and pull the **YELLOW HANDLE** to the **LEFT** and at the same time pull up on the **FRONT TOP MOLDING** and remove. The **GLASS** can now be pulled out towards you and removed. **TAKE CARE** while moving; set glass on a safe surface.



14. Through the open **Coin Door**, remove the **RETAINING RING** at the rear of the **CASH BOX** and open. Remove the **PINBALLS** & the **PLUMB BOB** from the **SPARE PARTS BAG**. (Save the other spare parts in cabinet). Install the **PINBALLS** by placing them on the playfield so they can roll into the **Outhole Ball Trough**.

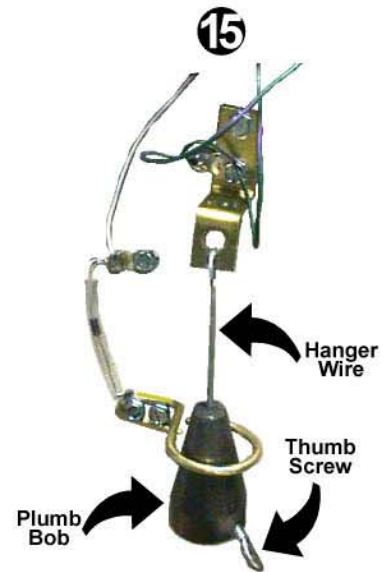

15. Install the **PLUMB BOB** on the **Hanger Wire** & tighten the **Thumb Screw**. Loosening the **Thumb Screw** & lowering or raising the **PLUMB BOB** makes the **Games Tilt Function** more or less sensitive.



**STERN**  
**PINBALL, INC.**  
**1-800-542-5377**

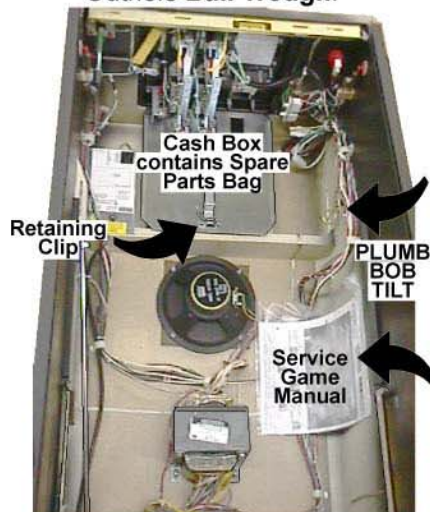

Remove the **PINBALL GAME MANUAL** (stapled to side of the left wall of the cabinet). Review **Section 1, Chapter 1**, which describes how to lift the playfield to access the **Plumb Bob Tilt Assembly**. The manual gives you all the important information you need to prepare for final set-up and other important information (such as Parts, Diagnostics, Schematics and more...).

**ALWAYS STORE THE MANUAL & INFORMATION SHEETS INSIDE THE CABINET WHEN NOT USING.**



# How to Secure the Backbox for Transporting

Sec. 1: After Set-Up

For more Backbox details & part numbers, see Section 4, Chapter 1, Parts Id. & Location, Backbox Assembly.

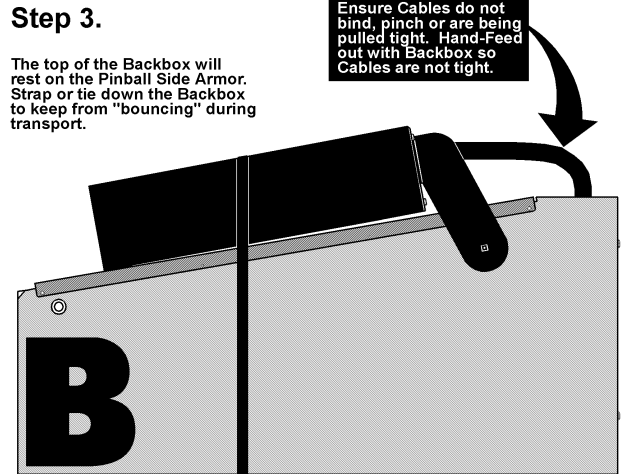
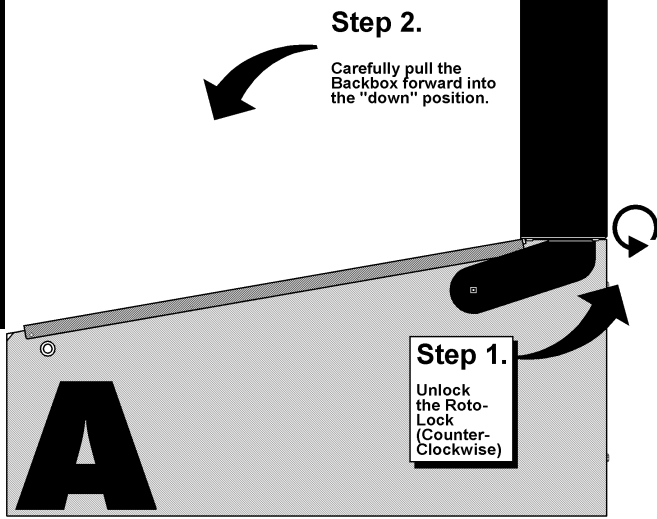

## Leg Leveler Adjustment

Attach the four (4) Leg Assemblies to cabinet corners with the eight (8) leg bolts provided .

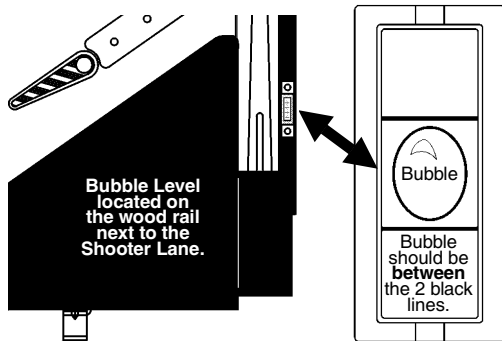

Start adjustment with the leg levelers *turned all the way in*.

View the *bubble* in the level provided on the right side wood rail.

Adjust the front or rear levelers as necessary to cause the bubble to float between the two (2) black lines.

Use a pinball to roll down the center of the playfield for side-to-side leveling.

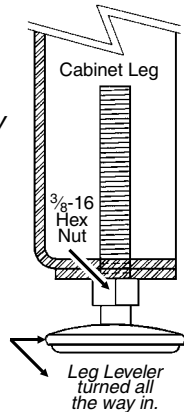

**YOUR PLAYFIELD PITCH IS NOW AT 6.5° AS REQUIRED FOR PROPER GAME PLAY!**

*Note: For custom adjustment greater than >6.5° can be achieved by turning out the rear leg leveler(s), however, it is not recommended.*

## Easy Access Service System - 2 Positions

With the front molding & glass removed, carefully lift the playfield (*take care when using the Bottom Arch to hoist*).

### Position 1

When lifted high enough, the **Playfield Support Slide Brackets** (Fig. 1A) can be seen and can clear the cabinet front (Fig. 1B). At this time, pull the playfield toward the front of the cabinet, checking that the mechanical components clear the cabinet front, then rest the playfield on the **Playfield Support Slide Brackets** at the front channel of cabinet (Fig. 1C);

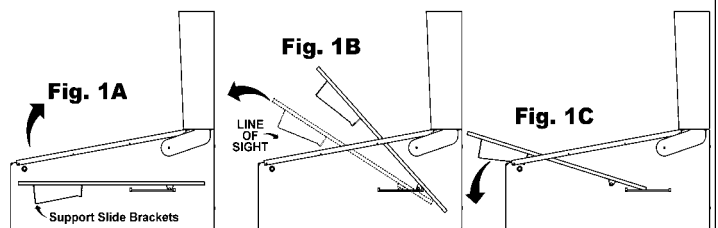

### Position 2

With the playfield at rest, hold the sides & pull toward the front of the cabinet (*approx. 6" to 8"*), until resistance is felt from **Edge Slide Brackets** stopping against the **Slide & Pivot Support Brackets** located on either side of the cabinet (Fig. 2A). At this time, swivel the playfield toward the Backbox, then rest on the top edge (Fig. 2B & 2C).

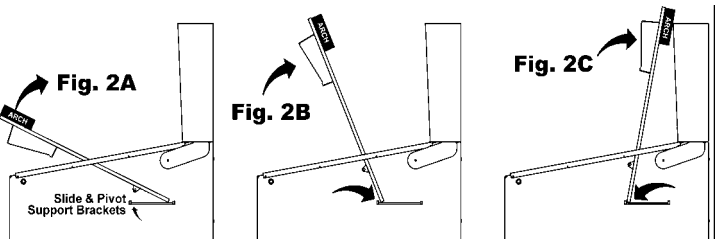

## Game Operation & Features

### Start of Game Features

#### Starting a Normal Game

Insert coin(s). The game generates a sound for the first coin & for each subsequent coin with the display indicating the number of credits posted. Press the **Start Button** and a start-up sound is produced, and the posted credits are reduced by one. Subsequent players can be added (**up to 4 can play!**) by pressing the **Start Button** before the end of ball 1 (*with sufficient credit in the game*).

The display now indicates the player or # of players selected from the total depressions of the **Start Button**. The display indicates the ball in play, and a ball is served to the *Shooter Lane*. An introduction is shown followed by Skill Shot Graphics and/or instructions. Pressing the **Start Button** after ball 1 of any player will start a new game (*if credits are available*), **but only** if the **Start Button** is depressed for 2-3 seconds. This delay is to avoid accidental "re-starts" of a game. **Note:** *Any partial credit remaining during game play after the end of ball 1, or power down, will be eliminated.*

#### Starting Team Play (Doubles!)

This option is adjustable with **Standard Adjustment (Adj.) 58, Team Scores** (Default = **NO**). If **Standard Adj. 58, Team Scores** is changed to **YES**, then Team Play will be made available. **Team Play only works in a 4-Player Game**. The totals for Players 1/ 3 (Team 1) & Players 2 / 4 (Team 2) are then displayed individually **as well as** the combined score for **BOTH TEAMS**.

#### Starting Tournament Play

This Pinball Game is **Tournament Ready**. **Optional Tournament betaBRITE Color Dot Display & hardware (sold separately) is available**. *Review Section 3, Chapter 6, GO TO TOURNAMENT MENU, for more info!*

Unlike a "Normal Game", the Tournament Game is started by depressing the **Tournament Start Button** (*located on the Front Molding, if installed*). If adequate credit(s) are posted **and a Tournament is started (set-up properly)** via the **Service Menu** (*select the "TOUR" Icon in the Main Menu*), the **Tournament Start Button** will flash. *Any adjustments or installs changed will not be in affect. Starting a Tournament Game defaults to preprogrammed Tournament Rules (e.g. No Extra Balls, Specials or Bonus Credits are awarded); however, starting a Normal Game after a Tournament Game will then revert back to any unique adjustments or installs performed previously.* **During** and **End of Game Features** operate in the same manner (*differences in adjustment defaults are present*).

### During Game Features

#### Feature Mode & Combination Shots

Features are lit on the playfield and started by completing *certain shots (e.g. completion of Target Banks, Orbit(s), Ramp(s) and/or any combination of the shots)*.

#### Multiball

Multiball is started after completion of certain features (*amount of balls used depends on game rules*).

#### Replay Feature

Replay awards are given as the player exceeds a High Score Level during game play. This can be adjusted with **Standard Adj. 3, Replay Award** (Default = **CREDIT**). Players exceeding the High Score Levels can receive: **CREDIT**, **EXTRA BALL**, or **SPECIAL**. Adjust to **NONE** if a replay award is not desired.

### End of Game Features

#### Game Endings

When all player(s) have played all balls (including any Extra Balls), the game ends. If power is interrupted during the course of a game, it will end that game (**see Starting a Normal Game**). Closure of the Plumb Bob Tilt Switch according to the number of tilts set, **Standard Adj. 22, Tilt Warnings** (Default = **2**) or prolonged closure, will end the current Ball-In-Play. Closure of the Slam Tilt Switch on the Coin Door ends the current game(s).

#### Match Feature

At the end of each ball, earned bonuses are collected. At the end of the last ball of a game (including any extra balls, if applicable), earned bonuses are collected, then the system produces a random 2-digit number (a multiple of 10; 00 to 90). Matching the last 2 digits of the player's score with this number awards a credit. In **Std. Adj. 19, Match Percentage** (Default = **9%**) can be changed from 0-10%. Changing the percentage to **0% displays** the "Match Animation" at the end of the game, however, will never match nor award anything. Changing this adjustment to **OFF** will **not display** the "Match Animation" nor award anything.

#### Entering Initials/Name

If player achieved a new *High Score* in a game or achieved a *Special Feature (if given)* the player may enter 3 Initials. In **Std. Adj. 36, HSTD (High Score To Date) Initials** (Default = **3 Initials**) can also be changed to **10-Letter Name**. Use the **Flipper Buttons** to choose a letter or character as seen on the Dot Display. Hitting the **Start Button** locks in the letter or character and proceeds to the next letter. The game then proceeds into the **Game-Over Mode** and then to the **Attract Mode**.

**Note:** **Standard Adj. 41, Custom Message** (Default = **ON**) can be displayed during the Attract Mode; enter letters in the same fashion. For more details on [Adjustments, see Section 3, Chapter 4](#).

*Continued Next Page.*



# Auto Percentaging

This game is equipped with Auto Percentaging, **Standard Adjustment (Adj.) 1, Replay Type** (Default = **AUTO**, adjustable). The *Replay Percent* is automatically adjusted, **Standard Adj. 2, Replay Percentage**, or you can set a *Fixed Replay Score*. Four levels may be selected. Adjustments allow awarding of a "CREDIT" (or your setting) as each level is exceeded. This can be adjusted with, **Standard Adj. 3, Replay Award** (Default = **CREDIT**). With the **Autopercentage Feature**, if the actual replay percentage is higher or lower than that desired, the game will automatically adjust for the new recommended percentage score(s). You may choose to make a different "score-to-beat" adjustment; this is done by utilizing **Standard Adj. 4, Replay Levels**. For more details with **Adjustments**, see Section 3, Chapter 4, **GO TO ADJUSTMENTS MENU**; also, see see Section 3, Chapter 5, **GO TO INSTALLS MENU** (via the **UTILITIES MENU**) for further customization of your Pinball Game.

Sec. 2: Game Op.

## Instruction Card

Below is a **COPY** of the Game Instruction Card (SPI Nr.: 755-5192-00-Y USA). For a replacement Game Instruction Card on Astrobright Solar Yellow Card Stock, add **-Y** to the end of the Part Number above. If your card is lost or damaged, simply **COPY** this page and **cut out** the card as a temporary replacement until a new card is ordered.

(Hint: **COPY & CUT** along the dotted line and fold in the center to keep the "COPY" sturdy.)

COPY & CUT



To download the Game Instruction Card, visit our website @ [www.SternPinball.com](http://www.SternPinball.com) and click on the "Pirates ... Pinball" or "Game Archive" Pop Bumper Link, then click "Instruction Card, ... (Multi-Language)"

FOLD HERE

Click on card to open the Instruction Card for printing.

*more like guidelines*

~~RULES:~~

**MULTIBALL**  
Hit the ship several times to sink it. This starts *Battle with the Kraken*. Shoot the Kraken several times to destroy it.

**EXTRA BALL**  
Collect treasure to *Light Extra Ball*.  
or  
Destroy the Kraken and collect the *Jack The Monkey Award*. Then collect *Light Extra Ball* from the Compass.

**SPECIAL**  
Defeat Davy Jones and collect the *Super Jackpot* from *Heart Multiball*. Then collect *Light Special* from the Compass.

Disney's Pirates of the Caribbean © Disney // Music Credits: Yo Ho (A Pirate's Life for Me) Words by Xavier Atencio and Music by George Bruns © 1967 Walt Disney Music Company (ASCAP). Copyright renewed. All Rights Reserved.

755-5192-00-Y USA



Table of Contents  
for Section 3

# SERVICE MENU

- Chapter 1, Service Menu Introduction .....8 – 12**
  - ▶ Table of Contents for Section 3.....7
  - ▶ **Service Switch X4 Set Acces & Use** .....8
    - ▷ Function 1: SERVICE CREDITS MENU ▷ Function 2: VOLUME MENU ▷ Function 3: SERVICE MENU
  - ▶ **Service Menu Introduction** .....9
    - ▷ How to Use This Section
  - ▶ **Disney PIRATES of the CARIBBEAN Pinball Service Menu Icon Tree** .....10-11
  - ▶ **Exit Service Menu**.....12
    - ▷ Problem / Solution Table
- Chapter 2, GO TO DIAGNOSTICS MENU .....13 – 20**
  - ▶ **Go To Switch Menu** .....14
    - ▷ Switch Test ▷ Active Switch Test ▷ Switch Alerts
  - ▶ **Go To Coil Menu** .....15
    - ▷ Single Coil Test ▷ Cycling Coil Test
  - ▶ **Go To Flash Lamps Menu** .....15
    - ▷ Single Flash Lamp Test ▷ Cycling Flash Lamp Test
  - ▶ **Go To Lamp Menu** .....16
    - ▷ Single Lamp Test ▷ All Lamps Test ▷ Row Lamps Test ▷ Column Lamps Test ▷ Ordered Lamps Test
  - ▶ **Ship Test** .....17
  - ▶ **Ball Trough Test** .....17
  - ▶ **Technician Alerts** .....18
  - ▶ **Knocker Test ▶ Sound / Speaker Test ▶ Begin Burn-In** .....19
  - ▶ **Dot Matrix Test**.....20
- Chapter 3, GO TO AUDITS MENU .....21 – 24**
  - ▶ **Earnings Audits [ #1 – #13 Definitions ]** .....21
  - ▶ **Standard Audits [ #1 – #59 Definitions ]** .....22-23
  - ▶ **Feature Audits [ #1 – #40 ]** .....24
  - ▶ **Tournament Audits [ #1 – #14 ]**.....24
- Chapter 4, GO TO ADJUSTMENTS MENU .....25 – 34**
  - ▶ **Standard Adjustments [ #1 – #63 ]**.....25-32
  - ▶ **Feature Adjustments [ #1 – #14 ]** .....33-34
- Chapter 5, GO TO UTILITIES MENU .....35 – 40**
  - ▶ **Go To Installs Menu**.....35-38
    - ▷ Install Extra Easy ▷ Install Easy ▷ Install Medium ▷ Install Hard ▷ Install Extra Hard ▷ Install 3-Ball ▷ Install 5-Ball
    - ▷ Install Competition ▷ Install Directors Cut ▷ Install Home Play ▷ Install Novelty ▷ Install Add-A-Ball ▷ Install Factory
  - ▶ **Enter Custom Message**.....39
  - ▶ **Set Custom Pricing** .....39
  - ▶ **Set Date / Time**.....40
  - ▶ **Go To Resets Menu** .....40
    - ▷ Reset Coin Audits ▷ Reset Game Audits ▷ Reset Grand Champion (Score) ▷ Reset High Scores ▷ Reset Credits
    - ▷ Reset Factory Settings
  - ▶ **Go To USB Menu** .....40
    - ▷ Dump to USB Memory Stick ▷ Update Game Code ▷ Backup to USB Memory Stick
- Chapter 6, GO TO TOURNAMENT MENU .....41 – 42**
  - ▶ **Start Tournament**.....41
  - ▶ **Stop Tournament**.....42
  - ▶ **View Tournament Data** .....42
  - ▶ **Tournament Audits**.....42
  - ▶ **Sign Messages A-B** .....42

Sec. 3: ...Menu Intro.



# Service Switch X4 Set Access & Use

The 4-Button Service Switch Set provides access for **three (3) functions** available for your use: 1: **SERVICE CREDIT**, 2: **VOLUME [-] / [+]** and 3: **SERVICE MENU**.

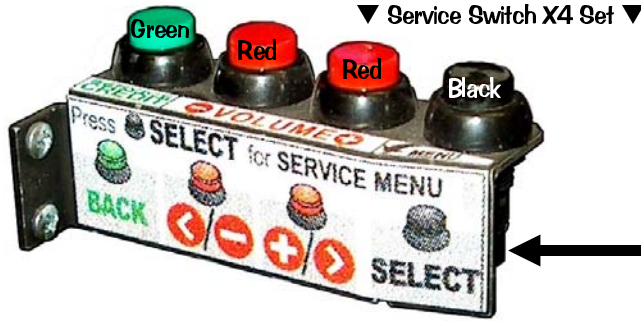

Inside Coin Door

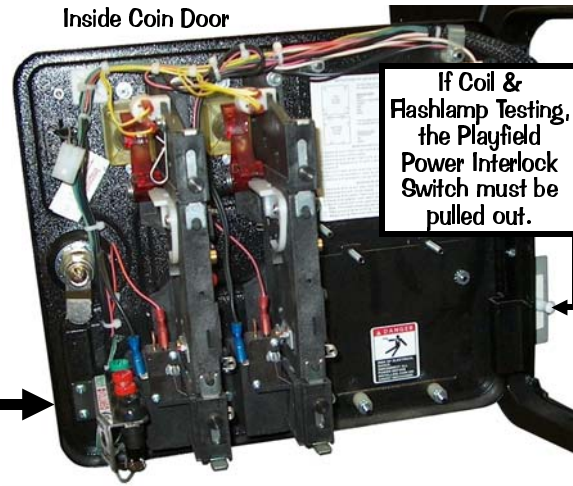

To access any of these **three (3) functions** you must first open the **Coin Door** (see pictorial above) with the Game in the **Attract Mode** (not already in any Function or Menu stated below) and then follow below.

Pushing the **GREEN** BUTTON first.



## ◀ Function 1: SERVICE CREDITS MENU

Pushing the **Green [ SERVICE CREDIT ] Button** first, adds a **Service Credit** per push (will not affect your audits as "paid" credits). This is useful for the technician to test games in regular play without affecting the game audits. Each depression adds **1 credit**; up to **50 credits** can be applied. **Standard Adjustment 23, Credit Limit**, determines this, however, it can be changed from 04-50; for details see **Chapter 4** of this **Section 3**.

**Note:** Once your credits are added, this menu will **automatically exit** a few seconds after the last button depression or when the **Green [ BACK ]** or **Black [ SELECT ] Button** is pushed. This function is disabled if **Standard Adjustment**

**38, Free Play**, is set to **YES**. The Service Credits are limited to the Credit Limit in addition to any paid credits present in the game (e.g. If the Credit Limit is 30, with 8 paid credits present, only 22 Credits can be applied.)

Pushing either **RED** BUTTON first.



Pushing either **RED** BUTTON first.

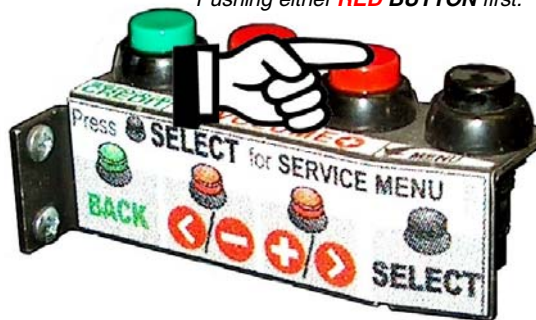

## ▲ Function 2: VOLUME MENU ▲

Pushing either of the **Red [ VOLUME ] Buttons** first, enters the **VOLUME MENU**. While in this Mode, to **DECREASE** the volume, hold down or depress the **1st Red [ </- ] Button** until desired the volume is achieved; to **INCREASE** the volume, hold down or depress the **2nd Red [ +/ > ] Button** until the desired volume is achieved.

**Note:** The volume can be set between **0-63**; Once your adjustments are made, this menu will **automatically exit** a few seconds after the last button depression or when the **Green [ BACK ]** or **Black [ SELECT ] Button** is pushed.

Pushing the **BLACK** BUTTON first.



## ◀ Function 3: SERVICE MENU

Pushing the **Black [ SELECT ] Button** first, enters the **SERVICE MENU**. Once in, navigate through all menus by depressing the **Service Menu Buttons**. Use the **Red [ </- ]** or **[ +/ > ] Buttons** to move **LEFT / RIGHT, NEXT/PREVIOUS (audits/adjustments)** or to **INCREASE / DECREASE** an adjustment (setting). Use the **Black [ SELECT ] Button** to select a highlighted **Icon**, move to the next line of text or to answer **"OK"** where applicable. Use the **Green [ BACK ] Button** to exit or escape back.

**Please read** Section 3, Chapters 2-6, for explanation on all **Icons and Menus**. **Read! Read! Read!**

Sec. 3: ...Menu Intro.





# Service Menu Introduction

**Important:** The **Switch Bracket** holds the **Playfield Power Interlock**. It is located just inside the **Coin Door** frame (see pictorial of the **Coin Door** on the previous page). The **Button Switch** for the **Playfield Power Interlock Switch** must be pulled out for electro-mechanical device testing or diagnostic purposes (this is required). If this button is pushed in, the **Playfield Power** is disabled while the **Coin Door** is **OPEN**.

## How to Use This Section

This section will cover all functions available in the **SERVICE MENU** in a *Step-By-Step* process. This section is divided into **chapters** which coincide with the **MAIN MENU** (will also provide more detailed information). The previous and following pages in this Chapter will instruct the operator on how to move through the Menus. *It's simple, easy and fun to use!*

To get into the **SERVICE MENU MODE** review "**Function 3: SERVICE MENU**" on the previous page. After Power-Up, push down the **Black [SELECT] Button** to begin. Looking at the display you will momentarily see "**SERVICE MENU**" followed by the **MAIN MENU**:



Use the **Red [ </- ] / [ + / > ] Buttons** to move the selected **Icon** left or right, and the **Black [ SELECT ] Button** to activate the selected **Icon**.

The **MAIN MENU** now appears with the "**DIAG**" **Icon** (**GO TO DIAGNOSTICS MENU**) highlighted:



As the operator views the Menu Screen(s), the **MORE MORE** symbols indicates that there are more **Icons** to select in each direction. The **Icon** selected will blink. Pushing the **Black [ SELECT ] Button** will select the **Icon** and the Menu Screen will change to the menu selected. Select the **Green [ BACK ] Button** to move backwards through the menu levels. Press the **Green [ BACK ] Button** repeatedly or select the "**QUIT**" **Icon** to completely exit the **SERVICE MENU Mode**.

View the **SERVICE MENU Icon Tree** on the next pages for a complete overview of all menus used in this system. The "**HELP**" **Icon** provides an explanation of **ICON** usage or any other information in the Menu where the "**HELP**" **Icon** was selected (when available).

**DIAG:** GO TO DIAGNOSTICS MENU | **AUD:** GO TO AUDITS MENU | **ADJ:** GO TO ADJUSTMENTS MENU  
**UTIL:** GO TO UTILITIES MENU (INSTALLS, CUSTOM MSG., CUSTOM PRICING, SET TIME, RESET & USB)  
**TOUR:** GO TO TOURNAMENT MENU (START TOURNAMENT, VIEW TOURNAMENT DATA, SIGN MESSAGES)

**>> TO UPDATE THE GAME CODE, REVIEW THE STEPS ON THE INSIDE FRONT COVER OF THIS MANUAL.**

Use both the manual and the display to help customize, troubleshoot and/or diagnose faults, if any.

Sec. 3: ...Menu Intro.

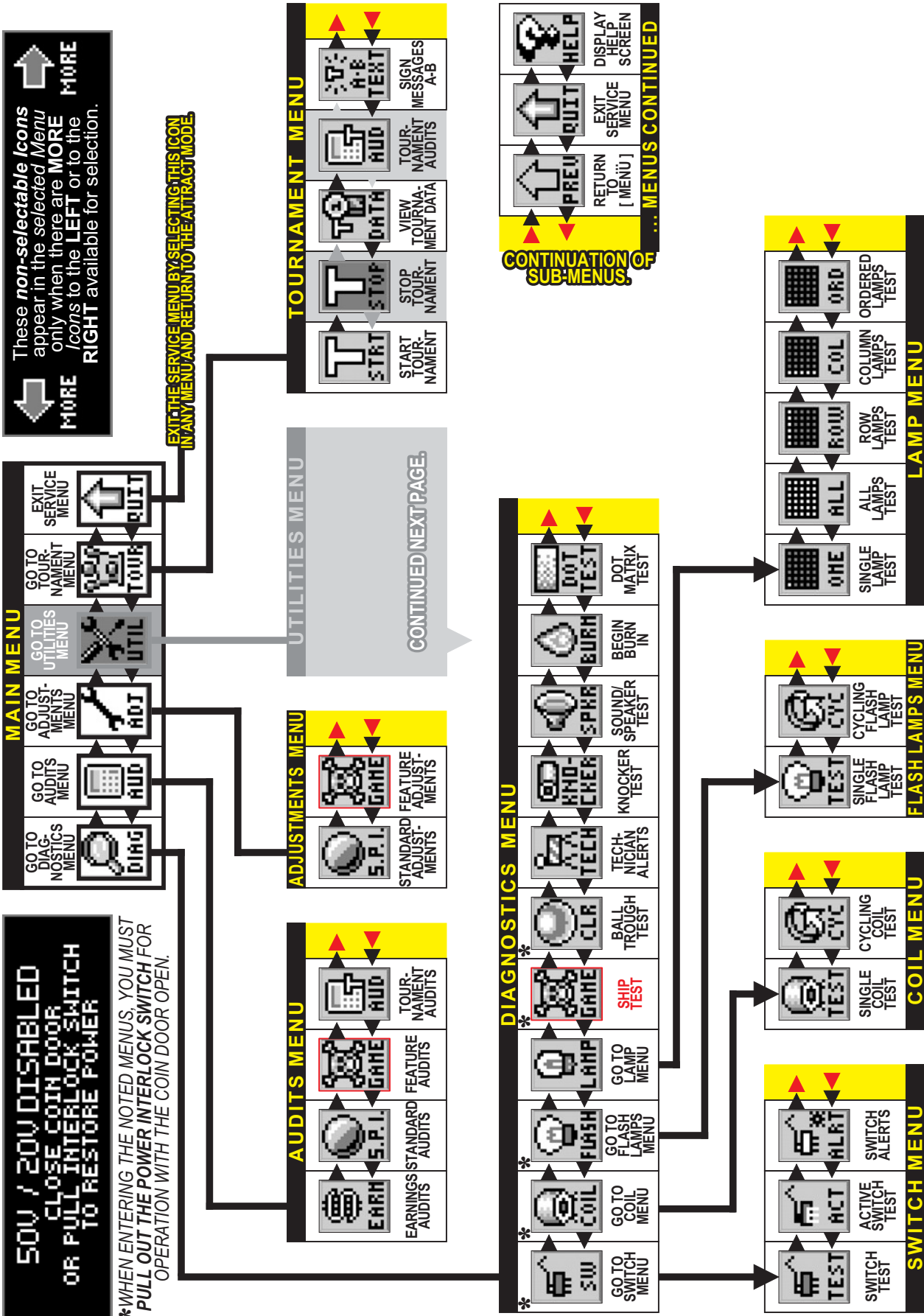

These non-selectable icons appear in the selected Menu only when there are MORE icons to the LEFT or to the RIGHT available for selection.

50V / 20V DISABLED  
CLOSE COIN DOOR  
OR FULL INTERLOCK SWITCH  
TO RESTORE POWER

\*WHEN ENTERING THE NOTED MENUS, YOU MUST  
PULL OUT THE POWER INTERLOCK SWITCH FOR  
OPERATION WITH THE COIN DOOR OPEN.

EXIT THE SERVICE MENU BY SELECTING THIS ICON  
IN ANY MENU AND RETURN TO THE ATTRACT MODE.

CONTINUATION OF SUB-MENUS.

... MENUS CONTINUED



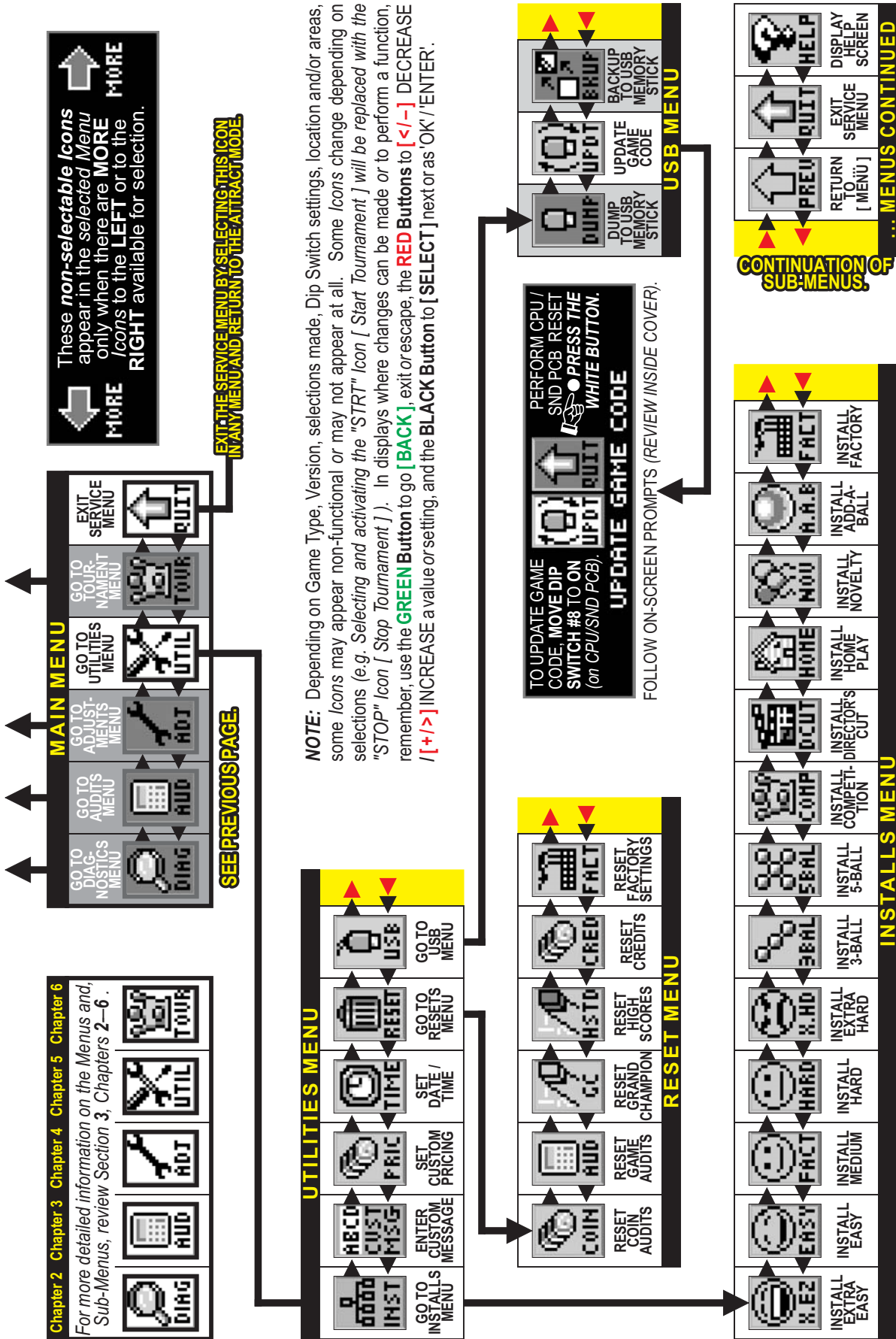



## Exit Service Menu

In the **MAIN MENU** and in all **SUB-MENUS** (where the "QUIT" Icon is present), if the "QUIT" Icon is selected and *activated*, or the **Green [BACK] Button** is selected repeatedly (depending on which sub-menu you're in...), the **SERVICE MENU Session** will be exited and returned to the **Attract Mode**.

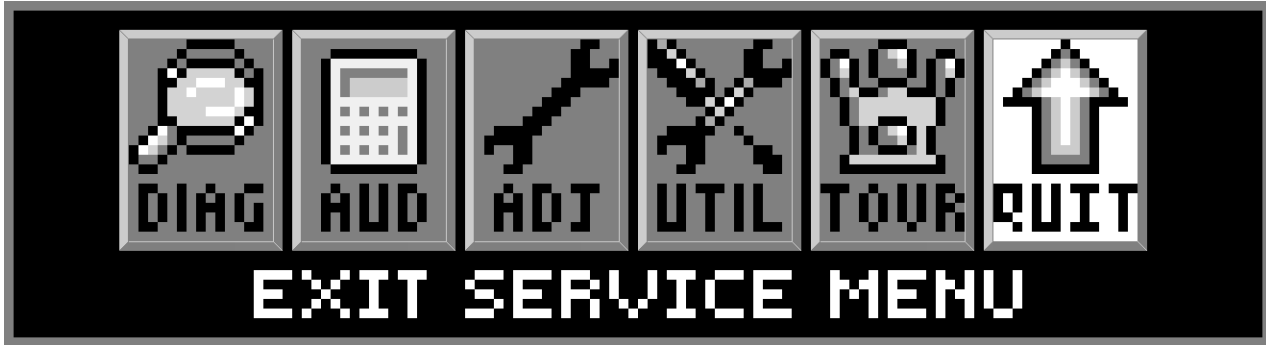

Turning the game on/off will start the *Power-Up Routine*. Upon **Power-Up**, the **DISPLAY** will indicate the **COUNTRY, FILE VERSION** and **LANGUAGE(S)** installed. **LANGUAGE/COUNTRY**: change via Dip Switch.



The below **Problem / Solution Table** was designed to answer some common problems frequently asked.

### Problem / Solution Table

PROBLEM	SOLUTION
Will not enter the <b>SERVICE MENU</b> after depressing the <b>Black [SELECT] Button</b> .	<ul style="list-style-type: none"> <li>• Check the Service Switches [ <b>GREEN, RED (x2) &amp; BLACK Buttons</b> ] for loose connections or bad ground.</li> <li>• Check the associated wiring harness to/from the CPU/Sound Board, Connector <b>J13</b>.</li> <li>• Check CPU/Sound Board for possible failure.</li> </ul>
All <b>Service Buttons</b> [ <b>••••</b> Buttons ] appear nonfunctional.	<ul style="list-style-type: none"> <li>• Check the Service Switches wiring harness for poor or no connection and/or broken wires.</li> </ul>
The <b>Green Button</b> in the Attract Mode will not enter the <b>SERVICE CREDITS MENU</b> to add Service Credits.	<ul style="list-style-type: none"> <li>• Check to make sure the Game is not in "<b>Free Play</b>." <i>If the game is set to Free Play, adding Service Credits is not required.</i></li> <li>• Check the Service Switches wiring harness for poor or no connection and/or broken wires.</li> </ul>
The <b>Display</b> "blanks out."	<ul style="list-style-type: none"> <li>• Check the Dot Matrix Display for loose wiring harness for poor or no connection and/or broken wires.</li> <li>• Check <b>F1 (3/4A Fuse)</b> on the Display Power Supply Board. Refer to Section 5, <b>SCHEMATICS &amp; TROUBLESHOOTING</b>.</li> </ul>
Icons "scroll" along continuously in the <b>MAIN MENU</b> .	<ul style="list-style-type: none"> <li>• Check for a stuck switch on either of the <b>Red Buttons</b>.</li> </ul>
The <b>Start</b> and <b>Flipper Buttons</b> do not select or activate <b>Icons</b> in the <b>SWITCH TEST MENU</b> .	<ul style="list-style-type: none"> <li>• This is normal. These switches are deactivated, as they are a part of the Switch Test. Refer to Section 3, Chapter 2, <b>GO TO DIAGNOSTICS MENU, Switch Test</b>.</li> </ul>
Can't move selection of <b>Icon</b> with the <b>Left</b> and/or <b>Right Flipper Buttons</b> .	<ul style="list-style-type: none"> <li>• Check the <b>Flipper Buttons</b> for loose connections or bad Ground and refer to Section 5, Chapter 2, <b>Playfield Wiring, #-Flipper Circuit Wiring Diagram</b>.</li> <li>• This is normal <b>only</b> in <b>Diagnostic's Switch &amp; Active Switch Tests</b> (see previous Problem).</li> </ul>
Some <b>Icons</b> appear non-functional in the <b>MENU</b> or missing.	<ul style="list-style-type: none"> <li>• Some functionality of the Service Menu may not have been completed during development. If exists, it should only be a non-critical function, such as the "HELP" <b>Icon</b>, which will explain the usage of icons. When completed, a software update will correct the problem. Software updates are announced via Service Bulletins (if critical) and on our website <a href="http://www.sternpinball.com/GAME-code.shtml">http://www.sternpinball.com/GAME-code.shtml</a>; view the Game Code Library Message Board Marquee or click <b>Previous Messages</b> for past announcements.</li> </ul>
In <b>COIL TEST MENU</b> , the coils and flashlamps <b>do not</b> fire after pressing the <b>Black [SELECT] Button</b> .	<ul style="list-style-type: none"> <li>• Ensure the <b>POWER INTERLOCK SWITCH is pulled out</b> (see the start of this Chapter).</li> </ul>
In the <b>SERVICE MENU</b> , the volume cannot be adjusted with either of the <b>Red Buttons</b> .	<ul style="list-style-type: none"> <li>• The Volume adjustment can only be made when in the <b>Attract Mode</b> (see the start of this Chapter).</li> </ul>
In the <b>SERVICE MENU</b> , the display seems to lock up, or the Help Display appears to be non-functional.	<ul style="list-style-type: none"> <li>• If you cannot clear the situation by exiting back one Menu, exit completely out of the <b>SERVICE MENU</b>, and re-enter. If the problem persists, call Technical Support for additional help.</li> </ul>

Sec. 3: ...Menu Intro.

**IF YOU NOTE ANY OTHER PROBLEMS or HAVE ANY SYMPTOMS NOT DESCRIBED ABOVE, PLEASE CALL TECHNICAL SUPPORT 800-542-5377 (708-345-7700 OPTION #1), SO WE MAY ASSIST YOU.**





To initiate, from the **MAIN MENU**, select the "DIAG" *Icon*. The **DIAGNOSTICS MENU** provides tests for switches, coils, flash lamps, lamps, sounds and dots in the Dot Matrix Display. Each feature may be tested manually or automatically after entering the **SERVICE MENU** (see Section 3, Chapter 1, Service Menu Introduction). The [ **CYCLING COIL TEST** ] / [ **FLASH LAMP TEST** ] may be used for a quick verification of automatic test functions. The [ **SWITCH TEST** ] / [ **SINGLE COIL TEST** ] / [ **SINGLE LAMP TEST** ] / [ **ALL LAMPS TEST** ] / [ **ROW LAMPS TEST** ] / [ **COLUMN LAMPS TEST** ] / [ **FLASH LAMP TEST** ] may be used for troubleshooting.

All **DIAGNOSTICS MENU** *Icons* and there usages are explained throughout this chapter in the same order as seen in the Dot Matrix Display. **NOTE:** Depending on Game Type, Version, selections made, Dip Switch settings, location and/or areas, some *Icons* may appear non-functional or may not appear at all. Some *Icons* change depending on selections (e.g. Selecting and activating the "STRT" *Icon* [ Start Tournament ] will be replaced with the "STOP" *Icon* [ Stop Tournament ] ). **Icons and/or functions, order and operation are subject to change.**

In displays where changes can be made or to perform a function, use the **GREEN Button** to go [ **BACK** ], exit or escape, the **RED Buttons** to [ **</-** ] MOVE BACK / LEFT / DECREASE / [ **+/>** ] MOVE FORWARD / RIGHT / INCREASE a value or setting, and the **BLACK Button** to [ **SELECT** ] next or as "OK / ENTER / ENERGIZE."

**Important:** Upon **Power-Up** (Game CPU Reset) or opening the **Coin Door** watch the **Display** for any **Alerts**.\*



This **audible / visual alert display** is shown when the **50V / 20V Power** is disabled (by opening the **Coin Door**). **PULL OUT THE INTERLOCK SWITCH ONLY WHILE IN THE SERVICE MENU FOR COIL OR SWITCH TESTING & BURN-IN WHEN THE COIN DOOR IS REQUIRED TO STAY OPEN FOR SERVICE BUTTON USE!** Pulling out the Power Interlock Switch or

pressing the 'escape' **Green [ BACK ] Button** will remove the alert display. Initial display presentation is accompanied by 3 audible tones (the bright display warning will go dim after approximately 30 seconds).



This **alert display** is shown momentarily during **Game Mode** or **Power-Up** to alert the operator of a device malfunction (device or mechanism doesn't energize or is energized repeatedly).

**OPERATOR ALERT!** works by monitoring any *switch activated device* that has the potential to trap a ball when disabled (e.g. in the *Shooter Lane, Scoop or Eject Holes, etc.*). This alert can

also appear if a switch associated with a device (e.g. *Ball Trough, Auto Plunger, etc.*) is stuck closed (caused by a *switch jam or stuck ball*); the game will activate the device a predetermined number of times and if the problem is still detected, this device or switch will be noted in **Switch Alerts** (next page) and/or **Technician Alerts** (Page 18).



Upon entering the **SERVICE MENU**, if an asterisk " \* " is displayed after the words "SERVICE MENU," the game has detected possible faulty devices, switches and/or missing pinballs. Press the either of the **Red Buttons** (short-cut to the **TECHNICIAN ALERTS MENU**) or continue into the **SERVICE MENU** (press the **Black Button** again), select the "DIAG" *Icon* and "TECH" *Icon* for the **Technician Alerts** information (Page 18).

**CAUTION!** Remove all pinballs from the Ball Trough prior to lifting the playfield to it's full upright position for servicing. **PULL OUT** the **Power Interlock Switch** for operation. To eject pinballs, select the "DIAG" *Icon* from the **MAIN MENU** to enter the **DIAGNOSTICS MENU**. Select the "CLR" *Icon* to enter the **BALL TROUGH TEST MENU**. Press the **Black [ SELECT ] Button**. To return to the **DIAGNOSTICS MENU**, press the **Green [ BACK ] Button**. This feature also useful to retrieve a pinball for game testing in **Switch** or **Coil Tests**.



## Go To Switch Menu

To initiate, from the **DIAGNOSTICS MENU**, select the "SW" *Icon*. Switches are configured in an 4 X 16 Matrix of Rows [ Switch Drives ] and Columns [ Sw. Returns ] with up to **64** possible switches. Dedicated Switches are configured in a 2 X 16 Matrix of Rows [ Dedicated Sw. Drives / Ground ] and Column [ Ded. Switch Returns ] with up to **32** possible dedicated switches (*includes the 8 dip switch positions*). The **SWITCH TEST MENU** consists of three (3) parts: **Switch & Active Switch Tests** and **Switch Alerts** to test *all* switches.

**Reminder:** The **Flipper & Start Buttons** (part of Switch Tests) are temporarily disabled as **Service Menu Navigation Buttons** during these test(s) so they can be tested and shown on-screen. Pressing the **Green [ BACK ] Button** (Dedicated Switch D-21), Light Green-Black / Black (GND), will exit **Switch Test** or **Active Switch Test**.



## Switch Test

To initiate, from the **SWITCH MENU**, select the "TEST" *Icon*. Ensure the **Power Interlock Switch** is pulled out if testing with the Coin Door open and the activation of coils is required. Upon entering **Switch Test**, you will notice that some switches are already indicated as closed. In the examples, the 4-Ball Trough Switches **#18, #19, #20 & #21** are shown closed (*pinballs at rest in the ball trough*), along with the Flipper E.O.S. Dedicated Switches **D-10 & D-12** (End-of-Stroke Switches are 'normally closed'). If the game has more flippers with E.O.S. Dedicated Switches, CPU Dip Switch Setting *other than 1-8 OFF* or switches stuck closed, more dots will be indicated (*enter Active Switch Test to reveal the names*).

In **Switch Test**, close each switch and observe the display (*switch closure is accompanied by a short audible tone*). In the example, the **Black [ SELECT ] Button** Dedicated Switch **D-24** is pressed. The Dot Matrix Display will light up (*highlight*) the corresponding dot in the on-screen matrix, display the *switch name, switch number and the Switch Drive / Return wire colors*. When not closing a switch, the display indicates **NONE** and the last switch number closure. For the Switch Matrix Grid and Dedicated Switch Grid, see **Find-It-In-Front: Dr. Pinball, DR. 4** or escape out of this test and enter **Active Switch Test** (*described below*) to view the names of the switches closed. **Note:** Pressing the **Green [ BACK ] Button** (Ded. Switch D-21), Lt. Green-Black / Black (GND), will exit the **Switch Test**.

**CAUTION! COIL MECHANISMS WHEN ACTIVATED HAVE FAST MOVING PARTS!** While performing **Switch Test** with the Coin Door closed or open (*with the Power Interlock Switch is pulled out*), **DO NOT USE YOUR FINGER** to test switches which are associated with a coil mechanism such as a Vertical Up-Kicker (*hole with a switch*), Slingshots, Bumpers, etc..



## Active Switch Test

To initiate, from the **SWITCH MENU**, select the "ACT" *Icon*. In **Active Switch Test**, if any switches are stuck closed (*or normally closed from the presence of pinball(s) as in the Ball Trough*), the display will flash the corresponding dot(s) in the on-screen matrix, display the *name and the Switch Drive / Return wire colors*. If more than one switch is closed, the switch information will change with each switch. This cycle continues until all switches are cleared or until **Active Switch Test** is exited. In the example, the **Black [ SELECT ] Button** Dedicated Switch **D-24** is pressed and held down. The display will cycle and flash each dot, naming each switch which is closed. To determine the *switch number*, compare the highlighted dot to the same position in the Switch Matrix Grid, see **Find-It-In-Front: Dr. Pinball, DR. 4**.



## Switch Alerts

To initiate, from the **SWITCH MENU**, select the "ALRT" *Icon*. In **Switch Alerts Menu**, possible inoperable switches are marked with an "X" (**OUT OF SERVICE**). Mark switches **IN** or **OUT OF SERVICE** by pressing the **Black Button** while the intended switch is highlighted and change with either of the **Red Buttons**. Switches which are determined as "OUT OF SERVICE" by the game or manually, will be automatically marked as "IN SERVICE" as soon as the game determines a valid switch closure (*after adjusting, fixing or replacing the switch, then testing/actuating the switch*). **Note:** A **Factory Reset** will also put the switch back "IN SERVICE" in which the game will need to redetermine if the switch should be marked **OUT OF SERVICE**.

Upon entering **Switch Test**, you will notice that some switches are already indicated as 'closed'.



D-24 position is highlighted and accompanied by a short audible tone when pressed.



After pressing the switch (to make it close), the display will indicate the last switch number.



## Typical Switch Wiring & Schematic

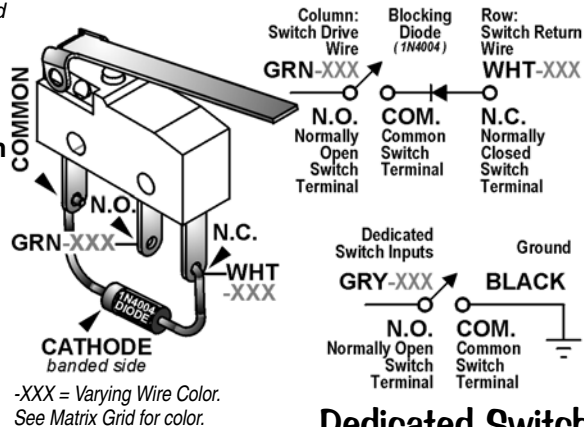

## Dedicated Switch Schematic

... D-24 is held down. The display will cycle and flash each dot, naming each switch ... closed.





## Go To Coil Menu

To initiate, from the **DIAGNOSTICS MENU**, select the "COIL" *Icon*. Coils **#01 – #16** are typically High Current Coils (*although Low Current Coils may be used in these positions & will be noted*). Coils **#17 – #32** are typically Low Current Coils. Flash Lamps are typically used in positions **#25 – #32** (*although Flash Lamps may be used in any position and will be noted*). Auxiliary Coils may be used in positions **#33 – #35**.

Remember, use the **GREEN Button** to go [ **BACK** ], exit or escape, the **RED Buttons** to [ **</-** ] GO BACK [ **+ / >** ] GO FORWARD, and the **BLACK Button** to [ **SELECT** ] ENERGIZE the coil (*solenoid*) or flash lamp.



## Single Coil Test

To initiate, from the **COIL MENU**, select the "TEST" *Icon*. Ensure the **Power Interlock Switch** is pulled out if testing with the Coin Door open. Upon entering

**Single Coil Test**, you will notice the #1 coil is shown. The Dot Matrix Display will indicate the *coil or flash lamp name, coil (solenoid) or flash lamp number and the Coil or Flash Lamp Power Line / Drive Transistor Control Line wire colors*. To determine the "Pin-Outs" from the I/O Power Driver Board, the Coil Voltage Gauge-Turns (*e.g. 23-800*) or lamp type (*e.g. #89 or #906 Bulb*), view the Coils Detailed Chart Table, see **Find-It-In-Front: Dr. Pinball, DR. ③** or for more on troubleshooting and diagnosing, see Section 5.



## Cycling Coil Test

To initiate, from the **COIL MENU**, select the "CYC" *Icon*. Ensure the **Power Interlock Switch** is pulled out if testing with the Coin Door open. The test pulses each regular coil or flash lamp sequentially (*cycling*) on the Playfield and in the Backbox (*if coils or flash lamps are used*). The Dot Matrix Display indicates the same information you will find in **Single Coil Test**.



## Typical Coil Wiring & Schematic

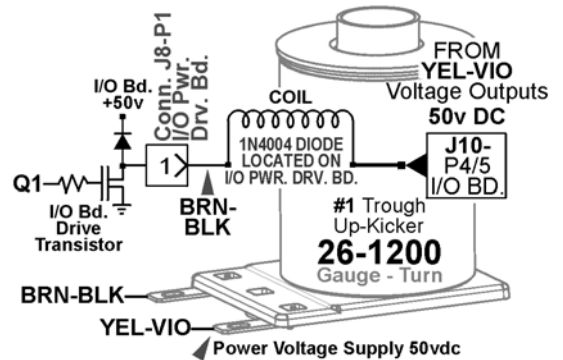

## Go To Flash Lamps Menu

To initiate, from the **DIAGNOSTICS MENU**, select the "FLASH" *Icon*. The two tests allows the technician to easily spot any burned-out flash lamps and replace them. Unlike **Single Coil Test**, which tests *all* coil (*solenoids*), including flash lamps, **Single** and **Cycling Flash Lamp Tests**, test only the flash lamps used in the game. Flash Lamps are typically used in positions **#25 – #32** (*although Flash Lamps may be used in any position and will be noted*).

Remember, use the **GREEN Button** to go [ **BACK** ], exit or escape, the **RED Buttons** to [ **</-** ] GO BACK / [ **+ / >** ] GO FORWARD, and the **BLACK Button** to [ **SELECT** ] ENERGIZE the flash lamp.



## Single Flash Lamp Test

To initiate, from the **FLASH LAMPS MENU**, select the "TEST" *Icon*. Ensure the **Power Interlock Switch** is pulled out if testing with the Coin Door open. Upon entering **Single Flash Lamp Test**, you will notice the first Flash Lamp is shown. The Dot Matrix Display will indicate the *flash lamp name, flash lamp number and the Flash Lamp Power Line / Drive Transistor Control Line wire colors*. To determine the "Pin-Outs" from the I/O Power Driver Board or lamp type (*e.g. #89 or #906 Bulb*), view the Coils Detailed Chart Table, see **Find-It-In-Front: Dr. Pinball, DR. ③** or for more on troubleshooting and diagnosing, see Section 5.



## Cycling Flash Lamp Test

To initiate, from the **FLASH LAMPS MENU**, select the "CYC" *Icon*. Ensure the **Power Interlock Switch** is pulled out if testing with the Coin Door open. The test pulses each flash lamp sequentially (*cycling*) on the Playfield and in the Backbox (*if flash lamps are used*). The Dot Matrix Display indicates the same information you will find in **Single Flash Lamp Test**.



## Bulb Types used for Flash Lamps

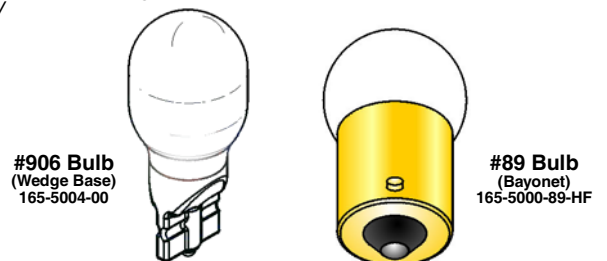



## Go To Lamp Menu

To initiate, from the **DIAGNOSTICS MENU**, select the "LAMP" *Icon*. Controlled lamps are configured in and 8 X 10 Matrix of Rows [ Lamp Returns / Ground ] and Columns [ Lamp Drives / 18VDC ] with up to 80 lamps possible. The **LAMP TEST MENU** consists of five (5) parts: **Single Lamp Test**, **Test All Lamps**, **Row Lamps Test**, **Column Lamps Test** and **Ordered Lamps Test\*** to test *all* lamps.

Remember, use the **GREEN Button** to go [ **BACK** ], exit or escape, the **RED Buttons** to [ **</->** ] GO BACK / LEFT / [ **+/>** ] GO FORWARD / RIGHT, and the **BLACK Button** to [ **SELECT** ] next or as "OK / ENTER."

Upon entering **Single Lamp Test**, ... the #1 lamp is shown. .... Display will light up ... the dot ... ▶



### Single Lamp Test

To initiate, from the **LAMP MENU**, select the "ONE" *Icon*. As each lamp is selected, the lamp will light at it's location on the playfield as well as the Dot Matrix

Display. Upon entering **Single Lamp Test**, you will notice the #1 lamp is shown. The Dot Matrix Display will light up (*highlight*) the corresponding *dot* in the on-screen matrix, display the *lamp name*, *lamp number* and the *Lamp Return / Drive wire colors*. For the Lamp Matrix Grid, see **Find-it-in-Front: Dr. Pinball, DR. Ⓞ**, at the beginning section of this Service Game Manual.



Upon entering **All Lamps Test**, ... the Dot Matrix Display is flashing "ALL LAMPS ON" ... ▶



### All Lamps Test

To initiate, from the **LAMP MENU**, select the "ALL" *Icon*. Upon entering **All Lamps Test**, you will notice the Dot Matrix Display is flashing **ALL LAMPS ON** and the

lamps on the playfield will be lit, alternating between the rows in the Lamp Matrix Grid. The Dot Matrix Display will light up (*highlight*) all of the *dots* in the on-screen matrix.



Upon entering **Row Lamps Test**, you will notice the #1 lamp row is shown. ▶



### Row Lamps Test

To initiate, from the **LAMP MENU**, select the "ROW" *Icon*. As each lamp row is selected, the lamps in the row will light on the playfield as well as the Dot Matrix

Display. Upon entering **Row Lamps Test**, you will notice the #1 lamp row is shown. The Dot Matrix Display will light up (*highlight*) the corresponding row of *dots* in the on-screen matrix, display the *lamp row number*, the *Lamp Return wire colors*, the *I/O PCB Connector* and *transistor number*.



Upon entering **Column Lamps Test**, you will notice the #1 lamp column is shown. ▶



### Column Lamps Test

To initiate, from the **LAMP MENU**, select the "COL" *Icon*. As each lamp column is selected, the lamps in the column will light on the playfield as well as the Dot

Matrix Display. Upon entering **Column Lamps Test**, you will notice the #1 lamp column is shown. The Dot Matrix Display will light up (*highlight*) the corresponding row of *dots* in the on-screen matrix, display the *lamp column number*, the *Lamp Drive (18VDC) wire colors*, the *I/O PCB Connector* and *IC number*.



Sec. 3: ... Diagnostics

## Bulb Types used for Control Lamps

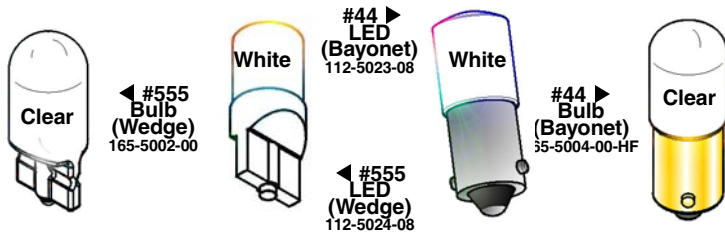

\* If not required in this game, *Icon* will not be shown.



### Ordered Lamps Test

To initiate, from the **LAMP MENU**, select the "ORD" *Icon*. If required, this *Icon* will appear in the **LAMP MENU**. Identical to **Single Lamp Test**, however, the lamps lit are not in the Lamp Matrix numeric order, but ordered or arranged in separate localized grouping(s) for easier lamp checking.

## Typical Lamp Schematic & Wiring

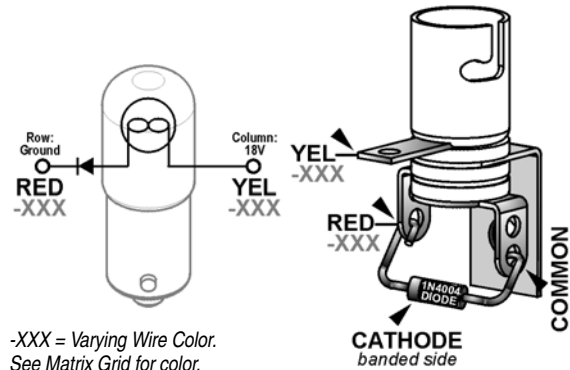

-XXX = Varying Wire Color. See Matrix Grid for color.







## Ship Test

To initiate, from the **DIAGNOSTICS MENU**, select the "GAME" *Icon*. Ensure the Power Interlock Switch is pulled out when testing with the Coin Door open. This Menu is provided to allow the technician a simple method of testing coils: **Q5** [ RAISE SAILS ], **Q28** [ LOWER SAILS LATCH ], **Q21** [ SHIP MOTOR ], **Q27** [ SHIP MOTOR RELAY ], SWITCH **63** [ SHIP HOME ] & SWITCH **62** [ SHIP FULLY SUNK ].  
**Assembly Removal:** Use this test to **DROP THE SAILS & SHIP** into the playfield for easy assembly removal (see the **BLUE** Pages, Pirate Ship Removal / Disassembly Procedure, Page 83).

**OPERATION NOTE :** If upon entering this test, the **Black Button** was pushed to **SINK THE SHIP** with the Power Interlock Switch still pushed in, then the Power Interlock Switch was pulled out (required to run the test), the motor will cycle the ship down (sink ship) **without dropping the sails**. The ship will "get stuck" with the motor running then will stop. The motor has a clutch which will keep the motor from burning out. Press the **Black Button** again to raise the ship so the sails can be lowered properly. Now, when the **Black Button** is pressed for the 3rd time, the Sails will be lowered and ship can continue all the way down.

- Upon entering the **SHIP TEST MENU**, Switch **63** [ SHIP HOME ] is indicated as closed. Press the **Black Button** to energize momentarily **Q5** [ RAISE SAILS ], then to pulse **Q28** [ LOWER SAILS LATCH ] and to energize **Q21** [ SHIP MOTOR ] + **Q27** [ SHIP MOTOR RELAY ] until the ship is "sunk" or fully down into the hole (if a switch detection is not made, the test will time-out stopping the motor).

- While the ship is "sinking," neither Switch **63** or Switch **62** is indicated as closed (they're in the open state).

- When the ship is "sunk" (fully down with lowered sails), Switch **62** [ SHIP SUNK ] is indicated as closed. Press the **Black Button** to energize **Q21** [ SHIP MOTOR ] + **Q27** [ SHIP MOTOR RELAY ] to raise the ship. **Q5** [ RAISE SAILS ] will be energized when the game detects Switch **63** [ SHIP HOME ] as closed.

- While the ship is "raising," neither Switch **63** or Switch **62** is indicated as closed (they're in the open state).

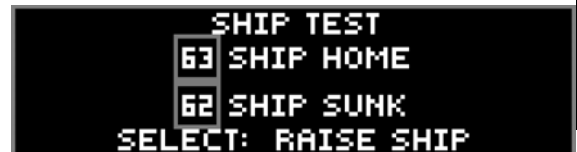
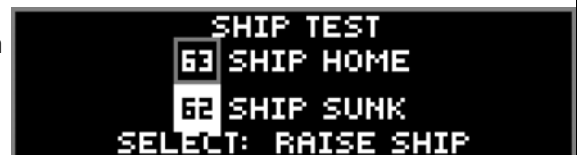
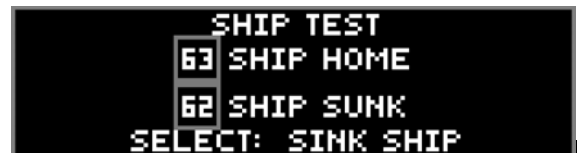
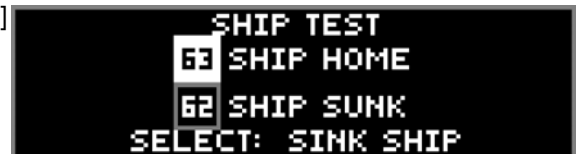

## Ball Trough Test

To initiate, from the **DIAGNOSTICS MENU**, select the "CLR" *Icon*. Ensure the **Power Interlock Switch** is pulled out if testing with the Coin Door open. This Menu is provided to allow the technician a simple method of removing the balls from the trough and also, to test functionality of the trough, ensuring proper trough operation. Upon entering **Ball Trough Test**, you will notice that four switches are already indicated as closed. In the example, the 4-Ball Trough Switches **#18**, **#19**, **#20** & **#21** are shown closed (pinballs at rest in the ball trough). To return to the **DIAGNOSTICS MENU**, press the **Green** [ BACK ] Button.



Press the **Black** [ SELECT ] Button to eject the ball in the first position Switch **#21** (VUK OPTO Trough #1 (R)). Simultaneously, the Dot Matrix Display and the playfield will eject the ball to the Trough Up-Kicker, eject from the Trough Up-Kicker into the Shooter Lane, momentarily closing Switch **#23** (Shooter Lane), and is ejected onto the playfield where the technician can easily

retrieve the pinball or allow the ball(s) to re-enter the trough to continue **Ball Trough Test**. The Dot Matrix Display indicates Switch **#18** (4-Ball Trough #4 (L)) as open as the remaining three (3) pinballs shift over one (1) position to the right. If the technician allows the ejected pinball to reenter the ball trough, the Dot Matrix Display will indicate Switch **#18** as closed. **REMINDER:** Switch **#22** is the stacking OPTO switch; If more than five (5) pinballs are used, the additional switches will be noted. In this game, **four (4)** pinballs are used and required for proper operation.



**CAUTION!** Continuous use off the above test may overheat the Trough Up-Kicker Coil.





## Technician Alerts

To initiate, from the **DIAGNOSTICS MENU**, select the "TECH" *Icon*. This Menu is provided to show any switch problems and/or missing pinballs. If this *Icon* is not blinking, there are NO TECHNICIAN ALERTS. If upon entering the **SERVICE MENU** the display indicated an asterisk ( \* ) and "USE -/+ TO VIEW TECH. ALERTS", alerts are present (*the above "TECH" Icon will also blink*).



After selecting this *Icon*, the display will indicate the alert(s). If there are 2 alerts present, the display will indicate (1/2) with the 1st alert on the display. Press the **Red [ + / > ] Button** to view the second alert (2/2). The second number in the parenthesis ( ) after the slash ( / ) indicates how many alerts are present. Refer to the start of this chapter (*bottom of Page 13*) regarding "Upon entering the **SERVICE MENU \***" indication and to **SWITCH ALERTS** (*Page 14*). To return to the **DIAGNOSTICS MENU**, press the **Green [ BACK ] Button**.

**NOTE ON SWITCH DETECTION :** During game play, activation of switches are continuously monitored. For a switch to be determined as inoperable *or* **OUT OF SERVICE**, up to twenty games *or* so must be played for a switch to be automatically marked as **OUT OF SERVICE**. In programming, if a switch is determined to be faulty, game play is compensated. Switches noted as **OUT OF SERVICE** are determined to be stuck closed *or* open depending on switch usage. Free up the switch actuator, adjust *or* replace, if necessary. Performing a valid switch closure will put the switch back "IN SERVICE."

Determination of switch usage can be checked in **Audits** (*review Sec. 3, Chp. 3, GO TO AUDITS MENU*). Find the associated Audit with the switch in question and check usage; compare the numbers to commonly used switches. After any switch is checked and repaired *or* replaced, it's suggested to test the switch in the **Switch Test** *or* **Single Coil Test** (*reviewed earlier in this chapter, Pages 14-15*) where the associated coil to the switch can be tested as well. After correcting the problem, the switch will marked "IN SERVICE" and the switch is again monitored as specified above. *Only you can determine if a switch marked OUT OF SERVICE is actually inoperable, or if it is just not getting actuated during game play.*

**NOTE ON PINBALL DETECTION :** While in **TECHNICIAN ALERTS MENU**, if the following is displayed, the game has detected one (1) *or* more pinball(s) missing and has compensated for the lost pinball(s) to provide normal game play.



During game play, a pinball can get trapped *or* stuck. If after approximately 15 seconds of inactivity *or* "no scoring," **Ball Search** is started. **Note:** *If the pinball is in the Plunger Lane or "held" on the flipper, no Ball Search will be performed.* The game will perform one **Ball Search** in an attempt to "find" *or* free-up the pinball.

If the game does not see a switch closure (*indicating the pinball has not been found*), the Dot Matrix Display may indicate [ **LOCATING PINBALLS PLEASE WAIT ...** ], during which **Ball Search** will continue until the timer runs out (*this feature will not happen if the game is in Competition Mode; Ball Search will continue until the pinball is found, unstuck and/or replaced manually*). The display will momentarily acknowledge the missing pinball(s). The game will provide another pinball into play and will compensate for the lost pinball. Game play will appear normal.

**Note:** *This detection and compensation will happen with every pinball, if each suffers the same fate of a ball trap. If all balls get trapped, the game cannot be played or started until the situation is rectified.*

**Important:** *Determine where the pinball is!* **Do not add pinball(s)** until it is determined the pinball(s) are indeed missing and not just stuck. The most common places for a pinball to be stuck is in device holes (*ejects and VUKs*) *or* ball troughs. Determine that all devices are functionally properly. Check around plastic pieces and ramps to see if the pinball got jammed *or* stuck.

When the found pinball *or* a replacement pinball is added to the Ball Trough, the **Technician Alert** will immediately clear and will then indicate any remaining alerts (*if present*) *or* **NO TECHNICIAN ALERTS**.

Enter the **BALL TROUGH TEST** (*review the previous page*) to cycle the pinballs and to check proper switch and coil operation. *If a pinball was added, and the originally stuck pinball has freed itself at a later time, the game will not operate correctly.*

**NOTE ON DEVICE MALFUNCTION :** While in **TECHNICIAN ALERTS MENU**, if the following is displayed, the game has detected a "device malfunction." Check the device indicated (coil and/or switch).





## Knocker Test

To initiate, from the **DIAGNOSTICS MENU**, select the "KNO-CKER" *Icon*. The digitally mastered "Knocker" is sounded. The *knocker sound* is used to alert the player if he/she has received a special, replay or a credit from the Match Award feature. Press the **Black [ SELECT ] Button** to activate the knocker. To return to the **DIAGNOSTICS MENU**, press the **Green [ BACK ] Button**.

**FACTOID:** The knocker got it's name from the 'original knocker' (20th century pinball games), which used a coil and when energized (fired), the plunger would strike a wood panel inside the cabinet.



## Sound / Speaker Test

To initiate, from the **DIAGNOSTICS MENU**, select the "SPKR" *Icon*. This system produces true digital stereo sound from Backbox & Cabinet Speakers or "Mono" on the Cabinet Speaker (when used by itself). This Menu is provided to allow the technician a simple method of testing the speakers if rewired or replaced.

Upon entering **Sound / Speaker Test**, you will notice the Dot Matrix Display indicating the first option of *available* music and/or sound(s) in this test. Press the **Red [ + / > ] Button** to cycle through the *available* music and/or sounds, and press the **Black [ SELECT ] Button** to play the option shown in the Dot Matrix Display. Press the **Green [ BACK ] Button** to exit.

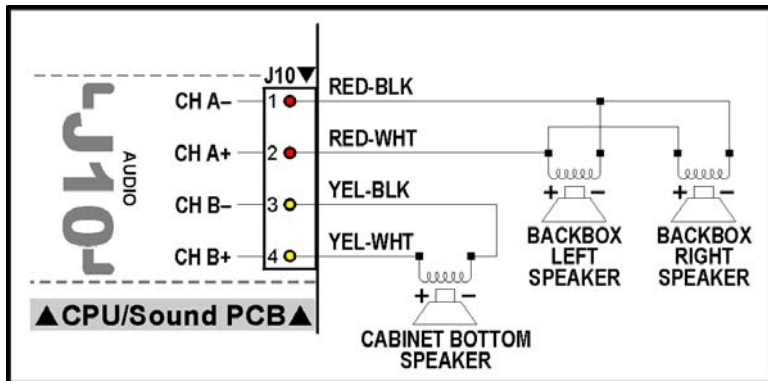

## Speaker Phase Testing

Connections to each of speakers are polarized and each must be connected appropriately for the best quality sound. If one speaker has the positive and negative connections reversed with respect to the other one, bass frequencies will not be produced properly and the overall sound quality will be poor. To test for proper speaker phasing, use the **Sound / Speaker Test** to cycle through the available music and sound. If the sound is not balanced or doesn't sound correct, check the speaker wiring.

1. Check each speaker for polarity markings. If the speakers have polarity markings, verify that the Backbox Speaker's **RED-BLK** Wires and the Cabinet Speaker **YEL-BLK** Wire(s) are connected to the negative (-) terminal.
2. Disconnect the speaker output **Connector J10 (AUDIO)** from the CPU / Sound PCB (in the Backbox) and connect a 1.5-volt battery across each speaker pair one at a time while observing the speakers.
3. Make sure the positive (+) battery terminal is connected to the positive lead [ J10, Pin-2, **CH A+** ] (**RED-WHT**) or [ J10, Pin-4, **CH B+** ] (**YEL-WHT**) each time. As the connection is made, check speaker cone movement; proper connections are indicated by outward movement.



## Begin Burn-In

To initiate, from the **DIAGNOSTICS MENU**, select the "BURN" *Icon*. After selecting this *Icon*, the **Burn-In Test** will start. Ensure the **Power Interlock Switch** is pulled out if testing with the Coin Door open (required for coil function). Upon entering **Burn-In Test**, the game will exercise all CPU I/O Functions: **Dot Matrix Display Test**, **Coil Cycling Testing**, **All Lamps Test** and **Sound / Speaker Test**. Press the **Green [ BACK ] Button**, to pause and to view the cumulative Burn-In minutes. Press the **Green [ BACK ] Button** again to return to the **DIAGNOSTICS MENU**.

**Note:** To reset Burn-In minutes back to **0:00**, see Section 3, Chapter 5, **GO TO RESET MENU** (via the **UTILITIES MENU**), **Reset Factory Settings**. **CAUTION:** Performing a **FACTORY RESET** will reset all other information as well (read Section 3, Chapter 5, **GO TO UTILITIES MENU**, for more information).





# Dot Matrix Test

To initiate, from the **DIAGNOSTICS MENU**, select the "DOT TEST" *Icon*. After selecting this *Icon* the **Dot Matrix Test** immediately begins. The Dot Matrix Display will immediately and continuously illuminate and cycle each of the **5 Tests for 1 pass each**. To return to the **DIAGNOSTICS MENU**, press the **Green [ BACK ] Button**.

### Test 1

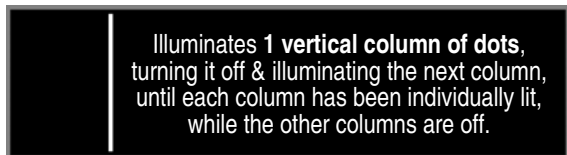

Illuminates **1 vertical column of dots**, turning it off & illuminating the next column, until each column has been individually lit, while the other columns are off.

### Test 2

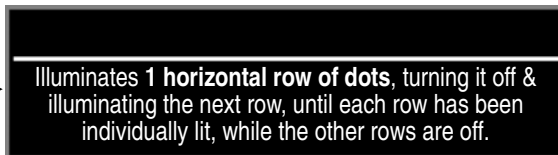

Illuminates **1 horizontal row of dots**, turning it off & illuminating the next row, until each row has been individually lit, while the other rows are off.

### Test 3

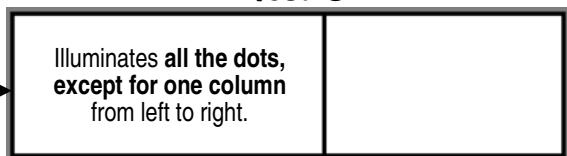

Illuminates **all the dots, except for one column** from left to right.

### Test 4

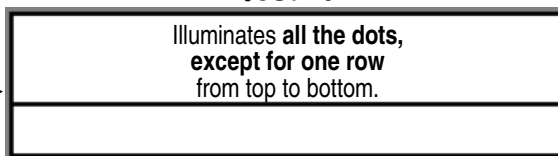

Illuminates **all the dots, except for one row** from top to bottom.

### Test 5



Illuminates **all the dots alternating even & odd**, in both the *rows and columns*.

### Test 1

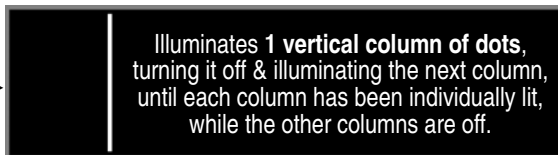

Illuminates **1 vertical column of dots**, turning it off & illuminating the next column, until each column has been individually lit, while the other columns are off.

Sec. 3: ... Diagnostics





To initiate, from the **MAIN MENU**, select the "AUD" *Icon*. The **AUDITS MENU** provides **112** Audits for accounting purposes and for evaluation of *Game Programming*. The Audits are divided into 4 groups: • **Earnings Audits [ #1 – #13 ]**, • **Standard Audits [ #1 – #59 ]**, • **Feature Audits (Programming Use Only) [ #1 – #40 ]** and • **Tournament Audits [ #1 – #14 ]**, "T AUD" *Icon* provided as an alternate to access Tournament Audits. For more information on the **TOURNAMENT MENU**, review **Section 3, Chapter 6, GO TO TOURNAMENT MENU**). **Coming Soon!** Audits / pertinent game data can be downloaded from the **USB MENU** (via the **UTILITIES MENU**), select the "DUMP" *Icon*. See **Section 3, Chapter 5, GO TO UTILITIES MENU**, for more information.

Audits which are named **Proprietary** are also for **Future Expansion** or **Programming**. Game code may get upgraded during production; compare all Audits in the Dot Matrix Display with the manual and make any corrections, as necessary. Audits are subject to change (*with or without notice*).

All **AUDITS MENU** *Icons* and their usages are explained throughout this chapter in the same order as seen in the Dot Matrix Display. **NOTE:** Depending on Game Type, Version, selections made, Dip Switch settings, location and/or areas, some *Icons* may appear non-functional or may not appear at all. **Icons and/or functions, order and operation are subject to change.**

In displays where changes can be made or to perform a function, use the **GREEN Button** to go [ **BACK** ], exit or escape, the **RED Buttons** to [ **</-** ] MOVE BACK / LEFT / [ **+ / >** ] MOVE FORWARD / RIGHT to view the next audit in the group, and the **BLACK Button** to [ **SELECT** ] the sub-menus.



### Earnings Audits [ #1 – #13 ]

To initiate, from the **AUDITS MENU**, select the "EARN" *Icon*. The Dot Matrix Display will indicate the *audit number (in this group)*, *audit name* and the *audit total or value*. The current audit will remain on the display until the next audit is viewed or when this sub-menu is exited.

- #1 **TOTAL PAID CREDITS [ 0 ]**: Total number of *Paid Credits*.
- #2 **FREE GAME PERCENTAGE [ 0% ]**: Percentage value is 'Total Free Plays' (Standard Audit 15) divided by 'Total Plays' (Standard Audit 16).
- #3 **AVERAGE BALL TIME [ 0:00 ]**: In seconds, the average ball time is derived from the total play time divided by Standard Audit 1, Total Balls Played.
- #4 **AVERAGE GAME TIME [ 0:00 ]**: The average game time is expressed in minutes and seconds.
- #5 **COINS THROUGH LEFT SLOT [ 0 ]**: Total 'Left Coin Slot' Dedicated Switch (**D-1**) closures.
- #6 **COINS THROUGH RIGHT SLOT [ 0 ]**: Total 'Right Coin Slot' Dedicated Switch (**D-3**) closures.
- #7 **COINS THROUGH CENTER SLOT [ 0 ]**: Total 'Center Coin Slot' Dedicated Switch (**D-2**) closures.
- #8 **COINS THROUGH FOURTH SLOT**: Total '4th Coin Slot' Dedicated Switch (**D-4**) closures.
- #9 **COINS THROUGH FIFTH SLOT**: Total '5th Coin Slot' Dedicated Switch (**D-5**) closures.
- #10 **TOTAL COINS [ 0 ]**: Total amount of coins registered through all the *Coin Slots*.
- #11 **TOTAL EARNINGS [ USD 0.00 ]**: Total cash value accumulated since the last Factory Reset occurred (review **Section 3, Chapter 5, GO TO RESET MENU** (via the **UTILITIES MENU**), **Reset Coin Audits**).
- #12 **METER CLICKS [ 0 ]**: Total number of money clicks accumulated.  
*Based on the country's lowest coin denomination used for the game credit.*
- #13 **SOFTWARE METER [ 0 ]**: Continuing total of Meter Clicks.  
*This audit cannot be reset; the display shows the constant addition of Meter Clicks.*



## Standard Audits [ #1 – #59 ]

To initiate, from the **AUDITS MENU**, select the "S.P.I." *Icon*. The Dot Matrix Display will indicate the *audit number (in this group)*, *audit name* and the *audit total or value*. The current audit will remain on the display until the next audit is viewed or when this sub-menu is exited.

- #1 **TOTAL BALLS PLAYED [ 0 ]**: Total number of *Regular* and *Extra Balls*.
- #2 **TOTAL EXTRA BALLS [ 0 ]**: Total number of *Extra Balls* awarded.
- #3 **EXTRA BALLS PERCENTAGE [ 0% ]**: Percentage value is 'Total Extra Balls' (Standard Audit 2) divided by 'Total Plays' (Standard Audit 16).
- #4 **REPLAY 1 AWARDS [ 0 ]**: Total Awards (*Credits, Extra Balls or Scores*) for Level 1.
- #5 **REPLAY 2 AWARDS [ 0 ]**: Total Awards (*Credits, Extra Balls or Scores*) for Level 2.
- #6 **REPLAY 3 AWARDS [ 0 ]**: Total Awards (*Credits, Extra Balls or Scores*) for Level 3.
- #7 **REPLAY 4 AWARDS [ 0 ]**: Total Awards (*Credits, Extra Balls or Scores*) for Level 4.
- #8 **TOTAL REPLAYS [ 0 ]**: Total Awards (*Credits, Extra Balls or Scores*) for exceeding *Replay Score Levels*.
- #9 **REPLAY PERCENTAGE [ 0% ]**: Percentage value is 'Total Replays' (Standard Audit 8) divided by 'Total Plays' (Standard Audit 16). *The percentage reflects replay total awards for exceeding replay score levels.*
- #10 **TOTAL SPECIALS [ 0 ]**: Total Awards (*Credits, Extra Balls, or Scores*) for making *Specials*.
- #11 **SPECIAL PERCENTAGE [ 0% ]**: Percentage value is 'Total Specials' (Standard Audit 10) divided by 'Total Plays' (Standard Audit 16).
- #12 **TOTAL MATCHES [ 0 ]**: Total *Credits* awarded for matching the last two digits of the score with the *System-Generated Match Number* at the end of the game. Percentage of *Match Credits* is adjustable from 0% to 10% or OFF by Standard Adjustment 19, *Match Percentage, if enabled (review Section 3, Chapter 4, GO TO ADJUSTMENTS MENU, Standard Adjustments)*.
- #13 **HIGH SCORE AWARDS [ 0 ]**: Total Awards (*Credits, Extra Balls, or Scores*) for exceeding the High-Score-To-Date scores.
- #14 **HIGH SCORE PERCENT [ 0% ]**: Percentage value is 'High Score Awards' (Standard Audit 13) divided by 'Total Plays' (Standard Audit 16).
- #15 **TOTAL FREE PLAYS [ 0 ]**: Total *Free Credits* for *Replays, High-Score-To-Date, Specials and Match*.
- #16 **TOTAL PLAYS [ 0 ]**: This total is derived by adding the sum of 'Total Paid Credits' (*Earnings Audit 1*) and 'Total Free Plays' (Standard Audit 13). *Note: Free credits are not recorded in the Audit until actually used.*
- #17 **0.0M–1.99M SCORES [ 00 ]**: Total number of games the Player's final score was between 0 and 1,999,990 points.
- #18 **2.0M–3.99M SCORES [ 00 ]**: Total number of games the Player's final score was between 2,000,000 and 3,999,990 points.
- #19 **4.0M–5.99M SCORES [ 00 ]**: Total number of games the Player's final score was between 4,000,000 and 5,999,990 points.
- #20 **6.0M–7.99M SCORES [ 00 ]**: Total number of games the Player's final score was between 6,000,000 and 7,999,990 points.
- #21 **8.0M–9.99M SCORES [ 00 ]**: Total number of games the Player's final score was between 8,000,000 and 9,999,990 points.
- #22 **10.0M–12.49M SCORES [ 00 ]**: Total number of games the Player's final score was between 10,000,000 and 12,499,990 points.
- #23 **12.5M–14.99M SCORES [ 00 ]**: Total number of games the Player's final score was between 12,500,000 and 14,499,990 points.
- #24 **15.0M–17.49M SCORES [ 00 ]**: Total number of games the Player's final score was between 15,000,000 and 17,499,990 points.
- #25 **17.50M–19.99M SCORES [ 00 ]**: Total number of games the Player's final score was between 17,500,000 and 19,999,990 points.
- #26 **20.0M–24.99M SCORES [ 00 ]**: Total number of games the Player's final score was between 20,000,000 and 24,499,990 points.
- #27 **25.0M–29.99M SCORES [ 00 ]**: Total number of games the Player's final score was between 25,000,000 and 29,999,990 points.

*Standard Audits 28-59 continued on the next page.*





## Standard Audits Continued

- #28 **30.0M–39.99M SCORES [ 00 ]** : Total number of games the Player's final score was between **30,000,000** and **39,999,990** points.
- #29 **40.0M–49.99M SCORES [ 00 ]** : Total number of games the Player's final score was between **40,000,000** and **49,999,990** points.
- #30 **50.0M–74.99M SCORES [ 00 ]** : Total number of games the Player's final score was between **50,000,000** and **74,999,990** points.
- #31 **75.0M–99.99M SCORES [ 00 ]** : Total number of games the Player's final score was between **75,000,000** and **99,999,990** points.
- #32 **100.0M–149.99M SCORES [ 00 ]** : Total number of games the Player's final score was between **100,000,000** and **149,999,990** points.
- #33 **150.0+M SCORES**: Total number of games the Player's final score was **150,000,000** points and over.
- #34 **AVERAGE SCORES [ 00 ]** : This total is derived by adding the Final Score of each game to a table and dividing this sum by 'Total Plays' (Standard Audit 16).
- #35 **SERVICE CREDITS [ 0 ]** : Total 'Green [ SERVICE CREDIT ] Button' Dedicated Switch (**D-21**) closures in **Attract Mode** (not while in the **SERVICE MENU**). See Section 3, Chapter 1, **Service Switch X4 Set Access & Use**, for how to receive Service Credits. See Section 3, Chapter 5, **GO TO RESET MENU** (via **GO TO UTILITIES MENU**), **Reset Credits**, for how to delete credits.
- #36 **BALL SEARCH STARTED [ 0 ]** : Total number of times the game performed a *Ball Search*.
- #37 **LOST BALL FEEDS [ 0 ]** : Total number of times the game added a pinball to play when it could not find a pinball after *Ball Search* (review Section 3, Chapter 2, **GO TO DIAGNOSTICS MENU, Technicians Alert [ Pinball Detection ]**).
- #38 **LOST BALL GAME STARTS [ 0 ]** : Total number of times the game started with a pinball missing from the ball trough at the start of a game (review Section 3, Chapter 2, **GO TO DIAGNOSTICS MENU, Technicians Alert [ Pinball Detection ]**).
- #39 **LEFT DRAINS [ 0 ]** : Total 'Left Outlane' Switch (**24**) closures.
- #40 **CENTER DRAINS [ 0 ]** : Total number of times the pinball had drained when the last switch closed was not the 'Left Outlane' (**24**) or the 'Right Outlane' Switch (**29**).
- #41 **RIGHT DRAINS [ 0 ]** : Total 'Right Outlane' Switch (**29**) closures.
- #42 **TILTS [ 0 ]** : Total 'Tilt Pendulum' Dedicated Switch (**D-17**) closures.
- #43 **TOTAL BALLS SAVED [ 0 ]** : Total number of times this feature was used. This feature is adjustable from **0:01–0:15, AUTO** or **NO BALL SAVES** (review Section 3, Chapter 4, **GO TO ADJUSTMENTS MENU, Standard Adjustment 48, Ball Save Time**). This feature is enabled at the start of each pinball and is disabled as soon as a predetermined number of switches are "closed" or the allocated time has expired.
- #44 **LEFT FLIPPER USED [ 0 ]** : Total 'Left Flipper Button' Dedicated Switch (**D-9**) closures in **Game Mode**.
- #45 **RIGHT FLIPPER USED [ 0 ]** : Total 'Right Flipper Button' Dedicated Switch (**D-11**) closures in **Game Mode**.
- #46 **0 - 1 MINUTE GAMES [ 0 ]** : Total games in which the total game time was between **0:00** and **1:00** minute.
- #47 **1 – 1.5 MINUTE GAMES [ 0 ]** : Total games where play time was between **1:00** and **1:30** minutes.
- #48 **1.5 – 2 MINUTE GAMES [ 0 ]** : Total games where play time was between **1:30** and **2:00** minutes.
- #49 **2 – 2.5 MINUTE GAMES [ 0 ]** : Total games where play time was between **2:00** and **2:30** minutes.
- #50 **2.5 – 3 MINUTE GAMES [ 0 ]** : Total games where play time was between **2:30** and **3:00** minutes.
- #51 **3 – 3.5 MINUTE GAMES [ 0 ]** : Total games where play time was between **3:00** and **3:30** minutes.
- #52 **3.5 – 4 MINUTE GAMES [ 0 ]** : Total games where play time was between **3:30** and **4:00** minutes.
- #53 **4 – 5 MINUTE GAMES [ 0 ]** : Total games where play time was between **4:00** and **5:00** minutes.
- #54 **5 – 6 MINUTE GAMES [ 0 ]** : Total games where play time was between **5:00** and **6:00** minutes.
- #55 **6 – 8 MINUTE GAMES [ 0 ]** : Total games where play time was between **6:00** and **8:00** minutes.
- #56 **8 – 10 MINUTE GAMES [ 0 ]** : Total games where play time was between **8:00** and **10:00** minutes.
- #57 **10 – 15 MINUTE GAMES [ 0 ]** : Total games where play time was between **10:00** and **15:00** minutes.
- #58 **15+ MINUTE GAMES**: Total games in which the total game time was **15:00** minutes and over.
- #59 **RECENT REPLAY PERCENT**: Percent figured with programming thresholds for a determined number of games. The % reflects replay total awards for exceeding replay score levels.





## Feature Audits [ #1 – #40 ]

To initiate, from the **AUDITS MENU**, select the "GAME" *Icon*. The Dot Matrix Display will indicate the *audit number (in this group)*, *audit name* and the *audit total or value*. The current audit will remain on the display until the next audit is viewed or when this sub-menu is exited.

**Feature Audits Definition: Programming Use Only.** *The proprietary information Total number of times a feature was started, awarded, lit, played and/or completed (awarded); also, the total number of Switch Closures during certain modes or features are tracked (a predetermined single/multiple variations of switch closures are used to determine the lighting and/or completion of the feature stated).*

- #1 MADE PARLAY HOLE
- #2 LEFT TOP LANE
- #3 CENTER TOP LANE
- #4 RIGHT TOP LANE
- #5 ALL TOP LANES
- #6 MADE LEFT ORBIT
- #7 ENTER LEFT RAMP
- #8 MADE LEFT RAMP
- #9 DISK TARGETS
- #10 LEFT SIDE LANE
- #11 RIGHT SIDE LANE
- #12 MADE JACK SCOOP
- #13 MADE CHEST
- #14 HIT SHIP
- #15 DESTROY SAILS
- #16 SINK SHIP
- #17 KRAKEN JACKPOT
- #18 DESTROY KRAKEN
- #19 HEART MULTIBALL
- #20 HEART JACKPOTS
- #21 HEART SUPER JP (JACKPOTS)
- #22 EXTRA BALLS
- #23 LIARS DICE
- #24 LD (LIARS DICE) BIG POINTS AWARD
- #25 LD MULTIPLIERS HELD AWARDS
- #26 LD BONUS MULTIPLIERS AWARDS
- #27 LD LIGHT CHEST AWARDS
- #28 LD LIGHT LOCK AWARDS
- #29 LD LIGHT PARLAY AWARDS
- #30 LD LIGHT SPECIAL AWARDS
- #31 LD LIGHT EXTRA BALL AWARDS
- #32 LD DROP SAILS AWARDS
- #33 LD LITTLE POINTS AWARDS
- #34 COMPASS NORTH
- #35 COMPASS SOUTH
- #36 COMPASS EAST
- #37 COMPASS WEST
- #38 LIT FOUR WINDS
- #39 FOUR WINDS
- #40 COMPLETED FOUR WINDS

Sec. 3: Go To Audits



## Tournament Audits [ #1 – #14 ] subject to change

This menu provides an alternate to access Tournament Audits which can be accessed from the **TOURNAMENT MENU** (review Section 3, Chapter 6, **GO TO TOURNAMENT MENU** for more information).







To initiate, from the **MAIN MENU**, select the "ADJ" *Icon*. The **ADJUSTMENTS MENU** provides **77** Adjustments to vary Game Functions to customize for your particular needs. The Adjustments are divided into 2 groups:

• **Standard Adjustments [ #1 – #63 ]** and • **Feature Adjustments (Programming Use Only) [ #1 – #14 ]**. For quick and easy customization of *Game Play Difficulty or Game Play Type* or how to **RESET ONLY** the Adjustments, review Section 3, Chapter 5, **GO TO INSTALLS MENU** (via the **UTILITIES MENU**). **Shortcut: Enter Custom Message** (Standard Adj. 41) and **Set Custom Pricing** (via Standard Adjustment 18, Game Pricing) can be quickly accessed via the **UTILITIES MENU**, see Section 3, Chapter 5, **GO TO UTILITIES MENU**.

Adjustments which are named **Proprietary** are also for **Future Expansion** or **Programming**. Game code may get upgraded during production; compare all Adjustments in the Dot Matrix Display with the manual and make any corrections, as necessary. Adjustments are subject to change (*with or without notice*).

All **ADJUSTMENTS MENU** *Icons* and there usages are explained throughout this chapter in the same order as seen in the Dot Matrix Display. **NOTE:** Depending on Game Type, Version, selections made, Dip Switch settings, location and/or areas, some *Adjustments* may appear non-functional or may not appear at all. **Adjustments and/or functions, order and operation are subject to change. If in doubt use the Factory Default Settings.**

In displays where changes can be made or to perform a function, use the **GREEN Button** to go [ **BACK** ], exit or escape, the **RED Buttons** to [ **</-** ] SELECT PREVIOUS [ **+ / >** ] SELECT NEXT when the adjustment name or setting is flashing and the **BLACK Button** to [ **SELECT** ] toggle between the ADJUSTMENT and SETTING.



## Standard Adjustments [ #1 – #63 ]

To initiate, from the **ADJUSTMENTS MENU**, select the "S.P.I." *Icon*. The Dot Matrix Display will indicate the *adjustment number (in this group), adjust. name, adjust. setting and comment line*. The current adjustment will remain on the display until the next adjustment is viewed or when this sub-menu is exited.

- #1 **REPLAY TYPE:** Set to **AUTO**, **NONE**, **FIXED** or **DYNAMIC**. Factory Default = **AUTO**. **AUTO** & **DYNAMIC** are based on the **Replay Percentage** (Standard Adjustment 2). • Select **FIXED** to give the player a **Replay Award** (Standard Adjustment 3) as the **Replay Levels** (Standard Adjustments 7-10) are reached. The **Replay Level(s)** (Standard Adjustments 7-10) will not adjust up or down. • Select **AUTO** to give the player a **Replay Award** (Standard Adjustment 3) as the **Auto Replay Start** (Standard Adjustment 5) score level is reached. This *score threshold* will automatically adjust up or down based on the **Replay Percentage** chosen (Standard Adjustment 2). The game periodically adjusts based upon the Player Base Skill Level. • Select **DYNAMIC** to give the player a **Replay Award** (Standard Adjustment 3) as the **Dynamic Replay Start** (Standard Adjustment 6) score level is reached. This *score threshold* will go down every game based on the **Replay Percentage** (Standard Adjustment 2) selected. • Select **NONE** to turn off Standard Adjustments 2-11.
- #2 **REPLAY PERCENTAGE:** Set between **01% – 50%**. Factory Default = **10%**. Adjustable only if **AUTO** or **DYNAMIC** is installed in Replay Type, Standard Adjustment 1. For [ **DYNAMIC** ] example, if the *score threshold* is 50,000,00 and the **Replay Percentage** selected is **10%**, every game a player does not reach the *score threshold*, the score to reach will drop by 5,000,000 (10% of 50M). This will continue every game until the *threshold score* is reached. Thus, if the score then drops to 15,000,000 after 7 games and is then achieved, the **Replay Award** (Standard Adjustment 3) is given. The original *score threshold* is added to 15,000,000 and is now 65,000,000. It will then take the same player 10 games to reach 15,000,000. *This adjustment is shown only if AUTO or DYNAMIC is installed in Replay Type* (Standard Adjustment 1).

Standard Adjustments 3-18 continued on the next page.



## Standard Adjustments continued.

- #3 **REPLAY AWARD:** Set to **CREDIT**, **TICKET\***, **TOKEN\*** or **EXTRA BALL**. Factory Default = **CREDIT**. Set the type of award to be given to the player when the appropriate Replay Score threshold or level is achieved. If awarding a **CREDIT**, **TICKET** or **TOKEN** is prohibited in your area, select **EXTRA BALL**. *This adjustment is not shown if NONE is installed in Replay Type (Standard Adjustment 1).*
- \*Note: If TICKET or TOKEN is selected, the game will require an optional Ticket or Token Dispenser and then Q24 Option (Standard Adj. 55) must be changed accordingly.*
- #4 **REPLAY LEVELS:** Set between 1 – 4 for the number of Replay Levels to be active. Factory Default = 1. *This adjustment is not shown if NONE is installed in Replay Type (Standard Adjustment 1).*
- #5 **AUTO REPLAY START:** Set between 5,000,000 – 150,000,000 (increments of 1,000,000) for the Auto Replay Start threshold. Factory Default = 20,000,000. *This adjustment is shown only if AUTO is installed in Replay Type (Standard Adjustment 1).*
- #6 **DYNAMIC REPLAY START:** Set between 5,000,000 – 150,000,000 (increments of 1,000,000) for the Dynamic Replay Start threshold. Factory Default = 60,000,000. *This adjustment is shown only if DYNAMIC is installed in Replay Type (Standard Adjustment 1).*
- #7 **REPLAY LEVEL #1:** Set between 5,000,000 – 150,000,000 (increments of 1,000,000). Factory Default = 15,000,000. Set the first or only Replay Level. *This adjustment is shown only if FIXED is installed in Replay Type (Standard Adjustment 1).*
- #8 **REPLAY LEVEL #2:** Set between 5,000,000 – 150,000,000 (increments of 1,000,000). Factory Default = 30,000,000. Set the second Replay Level. *This adjustment is shown only if FIXED is installed in Replay Type (Standard Adjustment 1) and 2 is installed in Replay Levels (Standard Adjustment 4).*
- #9 **REPLAY LEVEL #3:** Set between 5,000,000 – 150,000,000 (increments of 1,000,000). Factory Default = 45,000,000. Set the third Replay Level. *This adjustment is shown only if FIXED is installed in Replay Type (Standard Adjustment 1) and 3 is installed in Replay Levels (Standard Adjustment 4).*
- #10 **REPLAY LEVEL #4:** Set between 5,000,000 – 150,000,000 (increments of 1,000,000). Factory Default = 60,000,000. Set the fourth Replay Level. *This adjustment is shown only if FIXED is installed in Replay Type (Standard Adjustment 1) and 4 is installed in Replay Levels (Standard Adjustment 4).*
- #11 **REPLAY BOOST:** Set to **YES** or **NO**. Factory Default = **YES**. When set to **YES**, while **FIXED** or **AUTO** maintains the Replay Levels, Replay Boost works as follows: If the Replay Level is 7,000,000 (regardless of the Replay Percentage), and the Player scores 20M, and receives the Replay Award, the next game the Current Replay Level is added to this base. Thus the next game, the Replay Level is 14,000,000. The Player again scores 20M. The next game the Player will need to achieve 21,000,000 to earn the Replay Award. If the Player does not achieve 21,000,000, the next game reverts back to the original 7,000,000 or the new adjusted level maintained by the Fixed or Autopercentageing Feature. *This adjustment is shown only if AUTO or FIXED is installed in Replay Type (Standard Adjustment 1).*
- #12 **SPECIAL LIMIT:** Set between 1 – 5, **UNLIMITED** or **NO SPECIALS**. Factory Default = 1. Set the maximum number of *Specials* that may be accumulated per game.
- #13 **SPECIAL PERCENTAGE:** Set between 1% – 50%. Factory Default = 10%. This adjustment allows the operator to adjust how frequently the **Special Feature** is made available to the player. *This adjustment is not shown if NO SPECIALS is installed in Special Limit (Standard Adjustment 12).*
- #14 **SPECIAL AWARD:** Set to **CREDIT**, **TICKET\***, **TOKEN\***, **POINTS** or **EXTRA BALL**. Factory Default = **CREDIT**. Select **EX. BALL** or **POINTS** if awarding a **CREDIT** or **TICKET / TOKEN** is prohibited in your area. *This adjustment is not shown if NO SPECIALS is installed in Special Limit (Standard Adjustment 12).*
- \*Note: If TICKET or TOKEN is selected, the game will require an optional Ticket or Token Dispenser and then Q24 Option (Standard Adj. 55) must be changed accordingly.*
- #15 **FREE GAME LIMIT:** Set between 1 – 9, **UNLIMITED** or **NO FREE GAMES**. Factory Default = 5. Set the maximum number of *Free Games* that may be accumulated per game.
- #16 **EXTRA BALL LIMIT:** Set between 1 – 9, **UNLIMITED** or **NO EXTRA BALLS**. Factory Default = 5. Set the number of *Extra Balls* that may be accumulated per game.
- #17 **EXTRA BALL PERCENTAGE:** Set between 1% – 50%. Factory Default = 25%. This adjustment allows the operator to adjust how frequently the **Extra Ball Feature** is made available to the player. *This adjustment is not shown if NO EXTRA BALLS is installed in Extra Ball Limit (Standard Adjustment 16).*
- #18 **GAME PRICING:** There are two (2) methods available for *Coin Switch Programming*: **Standard & Custom**. Set between **AUSTRALIA 1 – UK 6** or **CUSTOM**. Factory Default = **USA 5**. **Shortcut: Set Custom Pricing and instructions, review Section 3, Chapter 5, GO TO UTILITIES MENU, Set Custom Pricing.** The appropriate Dip Switch Setting (Dip Sw. 1-8 location CPU/Sound PCB SW1) in relationship to the Pricing Scheme selected is important (*view the tables on the following pages for more information*).

Standard Adjustment 18, Game Pricing, continued on the next page.





# Standard Adjustment 18, Game Pricing, continued.

## USA Standard Pricing Select Table

CPU/SOUND PCB DIP SWITCH SW1 SETTING		COUNTRY SETTING OPTION(S)	COIN MECHANISMS (SWITCHES) COINS THRU ... SLOT:				PRICING SCHEME Number of Plays (Credits) for Price Amount Shown See "Appendix J" for Coin Cards Examples & Info!	Requires SPI Coin Card(s) Part Number
Pos.	1 2 3 4 5 6 7 8	Default Highlighted	LEFT	CENTER	RIGHT	4TH		
ON		USA 1	0.25	1.00	0.25		USD // UNITED STATES DOLLAR // [ \$ ]	
OFF	▼▼▼▼▼▼▼▼	USA 2						
		USA 3						
		USA 4						
		<b>USA 5</b>						
		USA 6						
		USA 7						
		USA 8						
		USA 9						
		USA 10						
							1 / \$ .25	
							1 / \$ .50    2 / \$ .75    3 / \$ 1.00	
							1 / \$ .50 <i>For USA 6 and USA 7 use:</i>	
							1 / \$ .50    5 / \$ 2.00    755-5400-02-Y	
							1 / \$ .50    2 / 4 X 25c <sup>t</sup> 3 / \$ 1.00 Bill	
							1 / \$ .50    4 / \$ 1.50    6 / \$ 2.00	
							1 / \$ .50    3 / \$ 1.00	
							1 / \$ 1.00 <i>USA 6 Note: If player uses x4 25c quarters = 2 plays. \$ bill = 3!</i>	
							1 / \$ .75    3 / \$ 2.00	

## International (non-Euro) Standard Pricing Select Table

CPU/SOUND PCB DIP SWITCH SW1 SETTING		COUNTRY SETTING OPTION(S)	COIN MECHANISMS (SWITCHES) COINS THRU ... SLOT:				PRICING SCHEME Number of Plays (Credits) for Price Amount Shown See "Appendix J" for Coin Cards Examples & Info!	Requires SPI Coin Card(s) Part Number
Pos.	1 2 3 4 5 6 7 8	Default Highlighted	LEFT	CENTER	RIGHT	4TH		
ON	▲▲▲▲	<b>AUSTRALIA 1</b>	0.20	1.00	2.00		AUD // AUSTRALIAN DOLLARS // [ \$ ]	
OFF	▼▼▼▼▼▼▼▼	AUSTRALIA 2						
ON	▲▲▲▲	<b>CANADA 1</b> [ 25c door ]	0.25	0.25	1.00	2.00	CAD // CANADIAN DOLLARS // [ \$ ]	
OFF	▼▼▼▼▼▼▼▼	CANADA 2 [ dollar door ]						
ON	▲▲▲▲	<b>CANADA 2</b> [ dollar door ]	1.00		2.00		1 / \$ .50    2 / \$ .75    3 / \$ 1.00	
OFF	▼▼▼▼▼▼▼▼							
ON	▲▲▲▲	<b>CROATIA</b>	1	2	5		HRK // CROATIAN KUNA // [ kuna ]	
OFF	▼▼▼▼▼▼▼▼							
ON	▲▲▲▲	<b>DENMARK 1</b>	1	5	10	20	DKK // DANISH KRONER // [ Kr ]	
OFF	▼▼▼▼▼▼▼▼	DENMARK 2						
ON	▲▲▲▲	<b>JAPAN 1</b>	100		100		JPY // JAPANESE YEN // ¥	
OFF	▼▼▼▼▼▼▼▼	JAPAN 2						
ON	▲▲▲▲	<b>MIDDLE EAST</b>	token		token		TOKEN // ME currency used to buy token //	
OFF	▼▼▼▼▼▼▼▼							
ON	▲▲▲▲	<b>NEW ZEALAND 1</b>	1.00		2.00		NZD // NEW ZEALAND DOLLAR // [ \$ ]	
OFF	▼▼▼▼▼▼▼▼	NEW ZEALAND 2						
ON	▲▲▲▲	<b>NORWAY 1</b>	10	5	20		NOK // NORWEGIAN KRONE // [ Kr ]	
OFF	▼▼▼▼▼▼▼▼	NORWAY 2						
ON	▲▲▲▲	<b>RUSSIA</b>	10	5	1		RUB // RUSSIAN RUBLE //	
OFF	▼▼▼▼▼▼▼▼							
ON	▲▲▲▲	<b>SO. AFRICA 1</b>	0.50	1.00	1.00	1.00	ZAR // SOUTH AFRICAN RAND // [ R ]	
OFF	▼▼▼▼▼▼▼▼	SO. AFRICA 2						
ON	▲▲▲▲	<b>SWEDEN 1</b>	1	5	10		SEK // SWEDISH KRONOR // [ kr ]	
OFF	▼▼▼▼▼▼▼▼	SWEDEN 2						
ON	▲▲▲▲	<b>SWITZERLAND 1</b>	1	2	5		CHF // SWISS FRANCS // [ Sf ]	
OFF	▼▼▼▼▼▼▼▼	SWITZERLAND 2						
ON	▲▲▲▲	<b>TAIWAN</b>	10		10		TWD // TAIWANESE DOLLAR //	
OFF	▼▼▼▼▼▼▼▼							
ON	▲▲▲▲	<b>UK 1</b>	0.10	0.50	1.00	0.20	GPB // UNITED KINGDOM POUNDS // [ £ ]	
OFF	▼▼▼▼▼▼▼▼	UK 2						
		UK 3						
		UK 4						
		<b>UK 5</b>						
		UK 6						
							3 / £ 1.00    7 / £ 2.00	
							4 / £ 1.00	
							1 / £ .50    5 / £ 2.00	
							1 / £ .30    4 / £ 1.00	
							1 / £ 1.00    3 / £ 2.00	
							3 / £ 2.00	

HIGHLIGHTED = Factory Default

Standard Adjustment 18, Game Pricing, continued on the next page.



Sec. 3: Go To Adjust.



# Standard Adjustment 18, Game Pricing, continued.

## Euro 1-12 Summary & International (Euro) Standard Pricing Select Table

CPU/SOUND PCB DIP SWITCH SW1 SETTING		COUNTRY SETTING OPTION(S)	COIN MECHANISMS (SWITCHES)				PRICING SCHEME			Requires SPI Coin Card(s) Part Number		
			COINS THRU ... SLOT:				Number of Plays (Credits) for Price Amount Shown See "Appendix J" for Coin Cards Examples & Info!					
Pos.	1 2 3 4 5 6 7 8		LEFT	CENTER	RIGHT	4TH	EUR // EUROPEAN UNION EUROS // [ € ]					
ON	SEEBELOW	Euro 1	0.50	1.00	2.00	0.20	1 /€ .50			755-5401-01-Y		
OFF	SETTINGS	Euro 2					1 /€ .50	5 /€ 2.00				755-5401-02-Y
		Euro 3					1 /€ .50	3 /€ 1.00				755-5401-03-Y
		Euro 4					1 /€ .50	6 /€ 2.00				755-5401-04-Y
		Euro 5					1 /€ .50	3 /€ 1.00	7 /€ 2.00			755-5401-05-Y
		Euro 6					2 /€ .50					755-5401-06-Y
		Euro 7					1 /€ 1.00	5 /€ 4.00				755-5401-07-Y
		Euro 8					1 /€ 1.00	3 /€ 2.00				755-5401-08-Y
		Euro 9					1 /€ 1.00	2 /€ 1.50	3 /€ 2.00			755-5401-09-Y
		Euro 10					1 /€ 1.00	3 /€ 2.00	7 /€ 3.00			755-5401-10-Y
		Euro 11					1 /€ 1.00	4 /€ 2.00				755-5401-11-Y
		Euro 12					2 /€ 1.00	9 /€ 4.00				755-5401-12-Y

For a different Euro Pricing Scheme (other than Factory Default listed below), scroll through Standard Adjustment 18: Euro 1-12 or CUSTOM\* for new setting (reference above Euro 1-12 Summary). Keep the Country Dip Switch Setting the same as listed below.

Pos.	1 2 3 4 5 6 7 8	Default Highlighted										
ON	▲	AUSTRIA Euro 9	0.50	1.00	2.00		1 /€ 1.00	2 /€ 1.50	3 /€ 2.00	755-5401-09-Y		
OFF	▼											
Pos.	1 2 3 4 5 6 7 8	Default Highlighted										
ON	▲	BELGIUM Euro 1	0.50	1.00	2.00		1 /€ .50			755-5401-01-Y		
OFF	▼											
Pos.	1 2 3 4 5 6 7 8	Default Highlighted										
ON	▲	FINLAND Euro 8	0.50	1.00	2.00		1 /€ 1.00	3 /€ 2.00		755-5401-08-Y		
OFF	▼											
Pos.	1 2 3 4 5 6 7 8	Default Highlighted										
ON	▲	FRANCE Euro 10	0.50	1.00	2.00		1 /€ 1.00	3 /€ 2.00	7 /€ 3.00	755-5401-10-Y		
OFF	▼											
Pos.	1 2 3 4 5 6 7 8	Default Highlighted										
ON	▲	GERMANY 1	0.50	1.00	2.00		1 /€ .50			755-5401-01-Y		
OFF	▼	GERMANY 2					1 /€ .50	5 /€ 2.00				755-5401-02-Y
		GERMANY 3					1 /€ .50	6 /€ 2.00				755-5401-04-Y
Pos.	1 2 3 4 5 6 7 8	Default Highlighted										
ON	▲	GREECE Euro 6	0.50	1.00	2.00		2 /€ .50			755-5401-06-Y		
OFF	▼											
Pos.	1 2 3 4 5 6 7 8	Default Highlighted										
ON	▲	ITALY 1	0.50		0.50		1 /€ .50			755-5401-01-Y		
OFF	▼	ITALY 2					1 /€ 1.00	3 /€ 2.00		755-5401-08-Y		
Pos.	1 2 3 4 5 6 7 8	Default Highlighted										
ON	▲	NETHERLANDS Euro 3	0.50	1.00	2.00		1 /€ .50	3 /€ 1.00		755-5401-03-Y		
OFF	▼											
Pos.	1 2 3 4 5 6 7 8	Default Highlighted										
ON	▲	PORTUGAL	0.50		0.50		1 /€ .50			755-5401-01-Y		
OFF	▼											
Pos.	1 2 3 4 5 6 7 8	Default Highlighted										
ON	▲	SPAIN Euro 3	0.50	1.00	2.00		1 /€ .50	3 /€ 1.00		755-5401-03-Y		
OFF	▼											

**HIGHLIGHTED** = Factory Default

For the associated Coinage Card required if the Factory Default Setting was changed, view on-line at:

<http://www.sternpinball.com/coinagecards.shtml>

You can download and print the replacement card. Adobe® Reader 5.0 or higher required (links on site). Use Yellow Card Stock: ASTROBRIGHTS® SOLAR YELLOW #65 FROM WAUSAU PAPER PRODUCTS (Stock #22731)

#19 **MATCH PERCENTAGE:** Set between 0% – 10% or OFF. Factory Default = 9%. At 0% the Match Animation Feature occurs at the end of the game but never awards the Match Award (Standard Adjustment 20). Set to OFF, no Match Animation Feature is shown.

#20 **MATCH AWARD:** Set to CREDIT, TICKET\* or TOKEN\*. Factory Default = CREDIT. This adjustment is not shown if OFF is installed in Match Percentage (Standard Adjustment 19).

\*Note: If TICKET or TOKEN is selected, the game will require an optional Ticket or Token Dispenser and then Q24 Option (Standard Adj. 55) must be changed accordingly.

#21 **BALLS PER GAME:** Set between 1 – 10. Factory Default = 3. Set the number of balls per game.

Standard Adjustments 22-36 continued on the next page.





## Standard Adjustments continued.

- #22 **TILT WARNINGS:** Set between **0 – 3**. Factory Default = **2**. Set the number of Plumb Bob Tilt Switch closures before the ball in play is tilted. *Each closure generates an audible alert and/or display alert.*
- #23 **CREDIT LIMIT:** Set between **4 – 50**. Factory Default = **30**. Set the maximum credits allowed.
- #24 **ALLOW HIGH SCORES:** Set to **YES** or **NO**. Factory Default = **YES**. When set to **YES**, if a player exceeds the Default Grand Champion or 1-4 High Scores, the player may receive a **High Score Award** (Standard Adjustment 25) and enter their **3 Initials** or **10-Letter Name** (Standard Adjustment 36). Set to **NO** to disable this feature. *The following Standard Adjustments 25-37 are not shown if **NO** is installed.*
- #25 **HIGH SCORE AWARD:** Set to **CREDIT**, **TICKET\*** or **TOKEN\***. Factory Default = **CREDIT**. Set the type of award to be given to the player when the appropriate **Grand Champion Score** or **High Score #1-#4** threshold or level is achieved. If awarding a **CREDIT**, **TICKET** or **TOKEN** is prohibited in your area, install **NO** in **Allow High Scores** (Standard Adjustment 24). *This adjustment is not shown if **NO** is installed in **Allow High Scores** (Standard Adjustment 24).*
- \*Note: If **TICKET** or **TOKEN** is selected, the game will require an optional Ticket or Token Dispenser and then **Q24 Option** (Standard Adj. 55) must be changed accordingly.*
- #26 **GRAND CHAMPION AWARDS:** Set between **0 – 5**. Factory Default = **1**. Set the number of **High Score Award(s)** (Std. Adj. 25), awarded for exceeding the Grand Champion Score (Standard Adjustment 31). *This adjustment is not shown if **NO** is installed in **Allow High Scores** (Standard Adjustment 24).*
- #27 **HIGH SCORE #1 AWARDS:** Set between **0 – 3**. Factory Default = **1**. Set the number of **High Score Award(s)** (Std. Adj. 25), awarded for exceeding the High Score #1 (Standard Adjustment 32). *This adjustment is not shown if **NO** is installed in **Allow High Scores** (Standard Adjustment 24).*
- #28 **HIGH SCORE #2 AWARDS:** Set between **0 – 2**. Factory Default = **0**. Set the number of **High Score Award(s)** (Std. Adj. 25), awarded for exceeding the High Score #2 (Standard Adjustment 33). *This adjustment is not shown if **NO** is installed in **Allow High Scores** (Standard Adjustment 24).*
- #29 **HIGH SCORE #3 AWARDS:** Set between **0 – 1**. Factory Default = **0**. Set the number of **High Score Award(s)** (Std. Adj. 25), awarded for exceeding the High Score #3 (Standard Adjustment 34). *This adjustment is not shown if **NO** is installed in **Allow High Scores** (Standard Adjustment 24).*
- #30 **HIGH SCORE #4 AWARDS:** Set between **0 – 1**. Factory Default = **0**. Set the number of **High Score Award(s)** (Std. Adj. 25), awarded for exceeding the High Score #4 (Standard Adjustment 35). *This adjustment is not shown if **NO** is installed in **Allow High Scores** (Standard Adjustment 24).*
- #31 **GRAND CHAMPION SCORE:** Set between **1,000,000 – 1,000,000,000** (increments of 1,000,000). Factory Default = **75,000,000**. Set the desired **Grand Champion Score** level a player needs to exceed to earn the **High Score Award** (Standard Adjustment 25). A score higher than the default, cannot be reset by Standard Adjustment 37, **HSTD Reset Count**. *The Grand Champion Score will revert to the Factory Default Score **ONLY** if a **Reset Grand Champion** is performed in the **RESET MENU** (via the **UTILITIES MENU**, see Section 3, Chapter 5) or if the game is without power for more than 12 hours after the CPU/Sound PCB Coin Cell Battery is expired or removed. This adjustment is not shown if **NO** is installed in **Allow High Scores** (Standard Adjustment 24).*
- #32 **HIGH SCORE #1:** Set between **1,000,000 – 1,000,000,000**. Factory Default = **55,000,000**. Set the desired **High Score #1** level a player needs to exceed to earn the **High Score Award** (Standard Adjustment 25). A score higher than the default, will be reset by Standard Adjustment 37, **HSTD Reset Count**. *The High Score will revert to the Factory Default Score **ONLY** if a **Reset High Scores** is performed in the **RESET MENU** (via the **UTILITIES MENU**, see Section 3, Chapter 5) or if the game is without power for more than 12 hours after the CPU/Sound PCB Coin Cell Battery is expired or removed. This adjustment is not shown if **NO** is installed in **Allow High Scores** (Standard Adjustment 24).*
- #33 **HIGH SCORE #2:** Set between **1,000,000 – 1,000,000,000**. Factory Default = **40,000,000**. Set the desired **High Score #2** level a player needs to exceed ... (continued in Standard Adjustment 32 definition above).
- #34 **HIGH SCORE #3:** Set between **1,000,000 – 1,000,000,000**. Factory Default = **30,000,000**. Set the desired **High Score #3** level a player needs to exceed ... (continued in Standard Adjustment 32 definition above).
- #35 **HIGH SCORE #4:** Set between **1,000,000 – 1,000,000,000**. Factory Default = **25,000,000**. Set the desired **High Score #4** level a player needs to exceed ... (continued in Standard Adjustment 32 definition above).
- #36 **HSTD (HIGH SCORE TO DATE) INITIALS:** Set to **3 INITIALS** or **10 LETTER NAME**. Factory Default = **3 INITIALS**. When set to **3 INITIALS**, the player is allowed only 3 initials to input. When set to **10 LETTER NAME**, the player is allowed to enter 10 initials to input. *This adjustment is not shown if **NO** is installed in **Allow High Scores** (Standard Adjustment 24).*

Standard Adjustments 37-49 continued on the next page.





## Standard Adjustments continued.

- #37 **HSTD (HIGH SCORE TO DATE) RESET COUNT:** Set between **100 – 9900** or **OFF** (*increments of 100*). Factory Default = **2000**. Set the number of games between "automatic resets" of High Scores back to the Factory Defaults for **ONLY** Standard Adj. **32 – 35, High Score #1 – #4**. *The High Score will revert to the Factory Default Scores when the number of games stated is reached. Reset High Scores can be performed in the RESET MENU (via the UTILITIES MENU, see Sec. 3, Chp. 5) anytime or if the game is without power for more than 12 hours after the CPU/Sound PCB Coin Cell Battery is expired or removed. This adjustment is not shown if NO is installed in Allow High Scores (Standard Adj. 24).*
- #38 **FREE PLAY:** Set to **YES** or **NO**. Factory Default = **NO**. When set to **YES**, no coins are required for Game Play.
- #39 **LANGUAGE:** Set to **ENGLISH, GERMAN, FRENCH, SPANISH** or **ITALIAN**. Factory Default = **ENGLISH**. Set the language for the game. Language of game is also shown in the Dot Display (*along with the Game Title and code version*) at the start-up routine which follows a game reset or power-up.
- #40 **PLAYER LANGUAGE SELECT:** Set to **YES** or **NO**. Factory Default = **YES**. When set to **YES**, after the player presses the **Start Button** (*to start a game with adequate credit*), the player has the option to choose a language by pressing either **Flipper Button** before game start (*options of languages installed are shown on the Dot Display*). **Note:** *If set to NO or if only one language is installed and the setting is set to YES, the game will start immediately after the Start Button press. Language(s) available are dependent on game destination from the factory. Other languages may be available on-line for download and installed on your game. With the proper dip switch installed, the language option(s) can be changed. For more information or help, call Technical Support at 800-542-5377 (708-345-7700).*
- #41 **CUSTOM MESSAGE:** Set to **ON, CHANGE** or **OFF**. Factory Default = **ON**. *Shortcut: Enter Custom Message and instructions, review Sec. 3, Chp. 5, GO TO UTILITIES MENU, Enter Custom Message.*
- #42 **FLASH LAMP POWER:** Set to **NORMAL, OFF** or **DIM**. Factory Default = **NORMAL**. When set to **DIM**, the Flash Lamps impulse power is reduced by **25%** and when set to **OFF** the Flash Lamps will not flash. For Flash Lamps used in this game, **Go To Flash Lamps Menu** via the **DIAGNOSTICS MENU** (*see Section 3, Chapter 2, GO TO DIAGNOSTICS MENU, Page 15*).
- #43 **COIL PULSE POWER:** Set to **NORMAL, HARD** or **SOFT**. Factory Default = **NORMAL**. When set to **HARD**, the coil pulse power is **increased** by **12.5%** of the normal pulse rate. When set to **SOFT** the coil pulse power is **decreased** by **12.5%** of the normal pulse rate. This adjustment is provided to compensate for *Low Line* or *High Line* voltage conditions where the solenoids (coils) appear to *kicking too weak* or *too hard*. Adjust as required.
- #44 **KNOCKER VOLUME:** Set to **NORMAL, OFF** or **LOW**. Factory Default = **NORMAL**. When set to **LOW**, the volume is decreased **50%**. When set to **OFF**, no sound is heard when the "knocker" is sounded. Test the knocker sound in the **Fire Knocker Test** via the **DIAGNOSTICS MENU** (*see Section 3, Chapter 2, GO TO DIAGNOSTICS MENU, Page 19*).
- #45 **GAME RESTART:** Set to **YES** or **NO**. Factory Default = **YES**. When set to **YES**, a new game may be started during any ball after the first ball is completed (*if credits allow*). Pressing the Start Button during the first ball will add additional players (*up to 4, if credits allow*). When set to **NO**, the game disables the Start Button after the first ball until the final ball is in play.
- #46 **BILL VALIDATOR:** Set to **YES** or **NO**. Factory Default = **NO**. *When set to YES, in Game Attract Mode an "Insert Bill Animation" is shown in the display (or just the absense of the Coin Animation). When set to NO, an "Insert Coin Animation" is shown. Not yet implemented.*
- #47 **MUSIC VOLUME:** Set between **1 – 15**. Factory Default = **1**. After volume is set via Service Buttons this adjustment can be utilized to adjust the background music (*1 all the way on, 15 all the way off*) while keeping the Special Sound Effects at the same level.
- #48 **BALL SAVE TIME:** Set between **0:01 – 0:15, AUTO** or **NO BALL SAVES**. Factory Default = **0:05**. When set to **NO BALL SAVES** this feature is unavailable. Set between **0:01** through **0:15** (*single increments*) for the ball to be sent back into play if the time set is not met (*per ball*). Set to **AUTO** to automatically adjust the Ball Save Timer based on the average ball time.
- #49 **TIMED PLUNGER:** Set to **OFF** or **0:01 – 1:00**. Factory Default = **OFF**. The plunger will "Autoplunge" the ball (*at the time set*) when the ball is at the beginning of play, waiting for the player.

Sec. 3: Go To Adjust.

Standard Adjustments 50-63 continued on the next page.





## Standard Adjustments continued.

- #50 **FLIPPER BALL LAUNCH:** Set to **OFF**, **LEFT FLIPPER**, **RIGHT FLIPPER**, **EITHER FLIPPER** or **BOTH FLIPPERS**. Default is **OFF**. This feature allows the player to operate the Auto Ball Launch with the Flipper Button(s) depending on which setting is chosen.
- #51 **COINDOOR BALL SAVER:** Set to **YES** or **NO**. Factory Default = **NO**. When set to **NO**, this feature is not available. When set to **YES**, this feature allows the Coin Door to be opened during game play; the ball will drain but the game will be placed "on hold". When the Coin Door is closed, the pinball will return to the Shooter Lane, and the game will resume. *Useful at locations where technicians change the cash box regularly at exact times of the day where players can be on the game.*
- #52 **COMPETITION MODE:** Set to **YES** or **NO**. Factory Default = **NO**. When set to **NO**, this feature is not available. Set to **YES**, this feature will equalize random game features and global score values during multi-player games by predetermined competition rules set by programming. If an **Install Competition** was made via the **INSTALLS MENU** (which automatically changes this setting to **YES**), and this setting was changed back to **NO**, the **Competition Mode** will be turned **OFF** (cancelled).
- #53 **CONSOLATION BALL:** Set to **YES** or **NO**. Factory Default = **NO**. When set to **YES**, the **EXTRA BALL** (Playfield Light Insert, location varies) will be lit on the last ball in play, if certain programming criteria is met.
- #54 **FAST BOOT:** Set to **YES** or **NO**. Factory Default = **YES**. When set to **NO** or if you hold both **Flipper Buttons** during Power-Up, this feature is not available and will display all normal Power-Up screens. When set to **YES**, the game will not display the normal informative Power-Up screens, specifically the CPU Version screen and the Location/Game ID screen. Regardless of the setting, normal Power-Up safety checks are still performed. **Not yet implemented.**
- #55 **Q24 OPTION:** Set to **COIN METER**, **TOKEN DISPENSER** or **KNOCKER**. Factory Default = **COIN METER**. This Coil (Solenoid) Location is left "open" at the Factory to allow for these optional Mechanisms to be added to the game. If selecting **TOKEN DISPENSER**, Standard Adjustments 3, 14, 20 & 25 should be changed to **TOKEN**. Call Technical Support at 1-800-542-5377 if more information is required on this option.
- #56 **TICKET DISPENSER:** Set to **YES** or **NO**. Factory Default = **NO**. This adjustment is required only for games which have an optional Deltronics (DL-1275-2 PCB Style, SPI Part Nr. 515-7275-00) Ticket Dispenser installed. Unique CPU Sound Bd. Dip Switch Setting required, changes the Default to **YES**.
- #57 **PLAYER COMPETITION:** Set to **YES** or **NO**. Factory Default = **YES**. **Competition Mode** unrandomizes feature events, and standardizes game play and rule sets (varies from game to game) for fair competitions. With adequate credit, to enter **Competition Mode**, hold both **Flipper Buttons** and watch the **Dot Display** for instructions before pressing the **Start Button**. General rules are covered in the Instruction Card. Other **Hints and/or Rules** can be made known on this game either visually (the **Dot Display** or **Flashing Light Inserts**) or can be audible. **Not yet implemented.**
- #58 **TEAM SCORES:** Set to **YES** or **NO**. Factory Default = **NO**. Set to **YES**, then Team Play will be made available. **Team Play only works in a 4-Player Game**. The totals for Players 1 / 3 (Team 1) & Players 2 / 4 (Team 2) are then displayed individually **as well as** the combined score for **BOTH TEAMS** to enable **Team Play (Doubles)**. See Section 2, Chapter 1, **Game Operation & Features**, for non-adjustable Features.
- #59 **LOCATION ID:** Set between **0** to **9999**. Factory Default = **0**. This adjustment allows the operator to assign a location identification number to the audit print-out sheet. (Will not be affected by a Factory Reset.)
- #60 **GAME ID:** Set between **0** to **9999**. Factory Default = **0**. This adjustment allows the operator to assign a game identification number to the audit print-out sheet. (Will not be affected by a Factory Reset.)
- #61 **TIME FORMAT:** Set to **12-HOUR** or **24-HOUR**. Factory Default = **12-HOUR**. This adjustments determines how the time is displayed. Time used in Tournament Functions and Data Dumps where a time stamp is required.
- #62 **COIN INPUT DELAY:** Set between **30** to **60** or **OFF**. Factory Default = **30**. This adjustment creates a short time delay between the moment the coin is inserted into the **Coin Slot** to the moment the CPU/Sound PCB registers the coin (30 = approximately 1/2 second).
- #63 **LOST BALL RECOVERY:** Set to **YES** or **NO**. Factory Default = **NO**. Set to **YES**, at the start of the 5th consecutive ball search (with no scoring between searches), the game will consider any balls in play to be permanently lost and will attempt to recover from this situation by serving a new ball into play from the ball trough. Set to **NO** (to suppress this adjustment behavior) for the game to perform the "ball search" indefinitely until the lost balls are found or replaced.



# STANDARD ADJUSTMENTS [ #1 – #63 ] ▼

Nr.	STANDARD ADJUSTMENT NAME	USA DEFAULT	YOUR SETTING
1	REPLAY TYPE	AUTO	
2	‡ REPLAY PERCENTAGE	10%	
3	‡ REPLAY AWARD	CREDIT	
4	‡ REPLAY LEVELS	1	
5	‡ AUTO REPLAY START	20,000,000	
6	‡ DYNAMIC REPLAY START	60,000,000	
7	‡ REPLAY LEVEL #1	15,000,000	
8	‡ REPLAY LEVEL #2	30,000,000	
9	‡ REPLAY LEVEL #3	45,000,000	
10	‡ REPLAY LEVEL #4	60,000,000	
11	‡ REPLAY BOOST	YES	
12	SPECIAL LIMIT	1	
13	‡ SPECIAL PERCENTAGE	10%	
14	SPECIAL AWARD	CREDIT	
15	FREE GAME LIMIT	5	
16	EXTRA BALL LIMIT	5	
17	‡ EXTRA BALL PERCENTAGE	25%	
18	GAME PRICING	USA 5	
19	MATCH PERCENTAGE	9%	
20	MATCH AWARD	CREDIT	
21	BALLS PER GAME	3	
22	TILT WARNINGS	2	
23	CREDIT LIMIT	30	
24	ALLOW HIGH SCORES	YES	
25	HIGH SCORE AWARD	CREDIT	
26	GRAND CHAMPION AWARDS	1	
27	HIGH SCORE #1 AWARDS	1	
28	HIGH SCORE #2 AWARDS	0	
29	HIGH SCORE #3 AWARDS	0	
30	HIGH SCORE #4 AWARDS	0	
31	GRAND CHAMPION SCORE	75,000,000	

Nr.	STANDARD ADJUSTMENT NAME	USA DEFAULT	YOUR SETTING
32	HIGH SCORE #1	55,000,000	
33	HIGH SCORE #2	40,000,000	
34	HIGH SCORE #3	30,000,000	
35	HIGH SCORE #4	25,000,000	
36	HSTD INITIALS	3 INITIALS	
37	HSTD RESET COUNT	2000	
38	FREE PLAY	NO	
39	LANGUAGE	ENGLISH	
40	PLAYER LANGUAGE SELECT	YES	
41	CUSTOM MESSAGE	ON	
42	FLASH LAMP POWER	NORMAL	
43	COIL PULSE POWER	NORMAL	
44	KNOCKER VOLUME	NORMAL	
45	GAME RESTART	YES	
46	BILL VALIDATOR	NO	
47	MUSIC VOLUME	1	
48	BALL SAVE TIME	0:05	
49	TIMED PLUNGER	OFF	
50	FLIPPER BALL LAUNCH	OFF	
51	COINDOOR BALL SAVER	NO	
52	COMPETITION MODE	NO	
53	CONSOLATION BALL	YES	
54	FAST BOOT	YES	
55	Q24 OPTION	COIN METER	
56	TICKET DISPENSER	NO	
57	PLAYER COMPETITION	YES	
58	TEAM SCORES	NO	
59	LOCATION ID	0	
60	GAME ID	0	
61	TIME FORMAT	12-HOUR	
62	COIN INPUT DELAY	30	
63	LOST BALL RECOVERY	YES	

Sec. 3: Go To Adjust.

**Factory Defaults Settings are subject to change during production (especially Standard Adjustments 2, 4, 5, 13, 16-17, 19, 31-35 & 47).**  
 ‡ Not all Standard Adjustments are shown. Depending on the setting (whether Factory Default or if changed by the operator), associated adjustments do not appear, if not required. **Note:** If Game Dip Switch other than USA is installed, different Defaults will appear.







## Feature Adjustments [ #1 – #14 ]

To initiate, from the **ADJUSTMENTS MENU**, select the "GAME" *Icon*. The Dot Matrix Display will indicate the *adjustment number (in this group), adjust. name, adjust. setting and comment line*. The current adjustment will remain on the display until the next adjustment is viewed or when this sub-menu is exited.

- #1 **SINK SHIP DIFFICULTY:** Set to **EXTRA EASY, EASY, MEDIUM, HARD** or **EXTRA HARD**.  
Factory Default = **MEDIUM**. Controls the number of shots required to sink the pirate ship.
- #2 **KRAKEN DIFFICULTY:** Set to **EXTRA EASY, EASY, MEDIUM, HARD** or **EXTRA HARD**.  
Factory Default = **MEDIUM**. Controls how fast the Kraken (monster squid) regenerates.
- #3 **PORT ROYAL DIFFICULTY:** Set to **EASY, MEDIUM** or **HARD**.  
Factory Default = **MEDIUM**. Controls how hard it is to destroy Port Royal.
- #4 **DAVY JONES DIFFICULTY:** Set to **EASY, MEDIUM** or **HARD**.  
Factory Default = **MEDIUM**. Controls how fast Davy Jones regenerates.
- #5 **1ST EXTRA BALL FROM TREASURE:** Set to **15, 20, 25, 30, 35, 40, 45** or **50**.  
Factory Default = **25**. Set the number of treasure hits required for the 1st Extra Ball to be lit.
- #6 **TREASURES TO NEXT EXTRA BALL:** Set to **30, 35, 40, 45, 50, 55, 60, 65, 70, 75** or **80**.  
Factory Default = **50**. Set the number of subsequent treasure hits required for the next Extra Ball to be lit.
- #7 **CHEST DIFFICULTY:** Set to **EASY, MEDIUM** or **HARD**.  
Factory Default = **MEDIUM**. Controls how hard it is to complete the Key Feature.
- #8 **PARLAY DIFFICULTY:** Set to **EASY, MEDIUM** or **HARD**.  
Factory Default = **MEDIUM**. Controls how many times and duration Parlay is lit [to collect by player].
- #9 **BROADSIDE DIFFICULTY:** Set to **EXTRA EASY, EASY, MEDIUM, HARD** or **EXTRA HARD**.  
Factory Default = **MEDIUM**. Controls how much time the player has to destroy the pirate ship.
- #10 **HEART MULTIBALL DIFFICULTY:** Set to **EASY, MEDIUM** or **HARD**.  
Factory Default = **MEDIUM**. Controls how which H-E-A-R-T letters [lamps lit] are spotted to the player at game start to achieve Heart Multiball faster. **EXTRA EASY** = H-E; **EASY** = H; **MEDIUM** = [none lit]
- #11 **PIRATE KING:** Set between **05 – 25**.  
Factory Default = **25**. Set the number of points to be collected by the player in one game to become the Pirate King (*High Score Feature : The player will be able to enter their initials / name\* if the player achieves this threshold*). \***3-initials** vs. **10-letter** name depends on Standard Adjustment **36** setting.
- #12 **GAUNTLET CHAMPION 1:** Set between **05 – 25**.  
Factory Default = **15**. Set the number of points to be collected by the player in one game to become the Gauntlet Champion 1 (*High Score Feature : The player will be able to enter their initials / name\* if the player achieves this threshold*). \***3-initials** vs. **10-letter** name depends on Standard Adj. **36** setting.
- #13 **GAUNTLET CHAMPION 2:** Set between **05 – 25**.  
Factory Default = **10**. Set the number of points to be collected by the player in one game to become the Gauntlet Champion 2 (*High Score Feature : The player will be able to enter their initials / name\* if the player achieves this threshold*). \***3-initials** vs. **10-letter** name depends on Standard Adj. **36** setting.
- #14 **GAUNTLET CHAMPION 3:** Set between **05 – 25**.  
Factory Default = **05**. Set the number of points to be collected by the player in one game to become the Gauntlet Champion 3 (*High Score Feature : The player will be able to enter their initials / name\* if the player achieves this threshold*). \***3-initials** vs. **10-letter** name depends on Standard Adj. **36** setting.



## FEATURE ADJUSTMENTS [ #1 – #14 ] ▼

Nr.	FEATURE ADJUSTMENT NAME	USA DEFAULT	YOUR SETTING
1	SINK SHIP DIFFICULTY	MEDIUM	
2	KRAKEN DIFFICULTY	MEDIUM	
3	PORT ROYAL DIFFICULTY	MEDIUM	
4	DAVY JONES DIFFICULTY	MEDIUM	
5	1ST EXTRA BALL FROM TREASURE	25	
6	TREASURES TO NEXT EXTRA BALL	50	
7	CHEST DIFFICULTY	MEDIUM	

Nr.	FEATURE ADJUSTMENT NAME	USA DEFAULT	YOUR SETTING
8	PARLAY DIFFICULTY	MEDIUM	
9	BROADSIDE DIFFICULTY	MEDIUM	
10	HEART MULTIBALL DIFFICULTY	MEDIUM	
11	PIRATE KING	25	
12	GAUNTLET CHAMPION 1	15	
13	GAUNTLET CHAMPION 2	10	
14	GAUNTLET CHAMPION 3	05	

*Factory Defaults Settings are subject to change during production*

*Note: If Game Dip Switch other than USA is installed, different Defaults will appear.*

**Sec. 3: Go To Adjust.**





To initiate, from the **MAIN MENU**, select the "UTIL" *Icon*. The **UTILITIES MENU** provides ways to quickly and easily customize your game with **Installs** (*pre-sets for game Standard & Feature Adjustments*), set-up a **Custom Message** (*short-cut to Standard Adjustment 41, Custom Message*), set-up **Custom Pricing** (*short-cut to Standard Adjustment 18, to the Custom Pricing Sub-Menu*), set-up the **Date and Time** (*required if the date and time is needed to be accurate for data dumps and for tournaments*), reset certain particular game data or perform a complete **Factory Reset** and to download game data, update or backup game code in the **USB MENU**.

All **UTILITIES, INSTALLS, RESETS MENU** and **USB MENU** *Icons* and there usages are explained throughout this chapter in the same order as seen in the Dot Matrix Display. **NOTE:** Depending on Game Type, Version, selections made, Dip Switch settings, location and/or areas, some *Icons* may appear non-functional or may not appear at all. **Installs (Adjustments), Icons and/or functions, order and operation are subject to change. If in doubt use the Factory Default Settings** (*review Install Factory on the next page*).

In displays where changes can be made or to perform a function, use the **GREEN Button** to go [ **BACK** ], exit or escape, the **RED Buttons** to [ **</-** ] MOVE BACK / LEFT / [ **+ / >** ] MOVE FORWARD / RIGHT to view the next audit in the group, and the **BLACK Button** to [ **SELECT** ] the sub-menus.



## Go To Installs Menu

To initiate, from the **UTILITIES MENU**, select the "INST" *Icon*. The **INSTALLS MENU** provides **13** **Installs** to vary **Game Play Difficulty** (*set with Feature Adjustments*) or **Game Play Type** and **Install Factory** (*restores all adjustments to Factory Defaults*).

For **detailed customization** or to check current **Adjustments Defaults** (*either changed by YOU in the Adjustments Menu or by this INSTALLS MENU or for Factory Default Settings*), see **Section 3, Chapter 4, GO TO ADJUSTMENTS MENU**. After completing one or more of the **Installs** in this chapter, go back to the **ADJUSTMENTS MENU** to see which **Standard and/or Feature Adjustments** have changed (*Feature Adjustments and/or settings are subject to change during production, and may differ than what is described in the tables at the end of this chapter*). The *Dot Display* will indicate if a setting is a *Factory Default* or not. If the settings are not to your liking, perform **one** of the following:

- 1.: **Manually** change the **Standard & Feature Adjustments** Settings (*perform this task in the ADJUSTMENTS MENU, see Section 3, Chapter 4, GO TO ADJUSTMENTS MENU*).
- 2.: **Install Factory** (*see the last install*) on how to reset all of the **Standard & Feature Adjustments** back to the *Factory Default Settings*.

Multiple **Installs can be set** to vary game play; however, for **Installs** that have *one or more* Adjustments in common, the **last** "Install" selected & *activated*, will **supersede** any previously changed Adjustment(s) from any prior **Installs**. Any adjustments which you changed and are not affected by the Install will remain as set.

For example, if you want a **5-BALL Game** set to **EXTRA EASY**: Select and *activate* the "5BAL" *Icon first* (which will typically change any **Feature** Difficulty Adjustments to **HARD**), *then* select & *activate* the "X.EZ" *Icon* to **change back** the Difficulty Adjustments to **EXTRA EASY**. However, if the "X.EZ" *Icon* was selected & *activated* first, *then* the "5BAL" *Icon* was selected & *activated*, the game will be set to a **5-BALL Game** set to **HARD**.

Remember, use the **GREEN Button** to go [ **BACK** ], exit or escape and the **BLACK Button** to [ **SELECT** ] to **INSTALL** your new setting(s).

**INSTALLS MENU** continued on the next page.

## INSTALLS MENU Continued.



Install Extra Easy, Easy, Medium (**Normal or Factory Settings**), Hard or Extra Hard

To initiate, from the **INSTALLS MENU**, select one of the "X.EZ," "EASY," "FACT," "HARD," or "X.HD" *Icons*. The Dot Matrix Display

will indicate the **INSTALL EXTRA EASY, EASY, MEDIUM, HARD or EXTRA HARD** depending on choice. Follow the on-screen prompts to perform the **Install**. Set the **Game Play Difficulty** level.



### Install 3-Ball

To initiate, from the **INSTALLS MENU**, select the "3BAL" *Icon*. The Dot Matrix Display will indicate the **INSTALL 3-BALL**. Follow the on-screen prompts to perform the **Install**.

Set the **Game Play Type** to 3 Balls per game (*Factory Default is 3 Balls per game, not including extra's...*).



### Install 5-Ball

To initiate, from the **INSTALLS MENU**, select the "5BAL" *Icon*. The Dot Matrix Display will indicate the **INSTALL 5-BALL**. Follow the on-screen prompts to perform the **Install**.

Set the **Game Play Type** to 5 Balls per game (*not including extra balls earned by the player, if any*).



### Install Competition

To initiate, from the **INSTALLS MENU**, select the "COMP" *Icon*. The Dot Matrix Display will indicate the **INSTALL COMPETITION**. Follow the on-screen prompts to perform the **Install**.

Set the **Game Play Type** to "Tournament" Rules. *Programming varies and is subject to change.*



### Install Director's Cut

To initiate, from the **INSTALLS MENU**, select the "DCUT" *Icon*. The Dot Matrix Display will indicate the **INSTALL DIRECTOR'S CUT**. Follow the on-screen prompts to perform the **Install**.

Set the **Game Play Type** to programmer's choice. *Programming varies and is subject to change.*



### Install Home Play

To initiate, from the **INSTALLS MENU**, select the "HOME" *Icon*. The Dot Matrix Display will indicate the **INSTALL HOME PLAY**. Follow the on-screen prompts to perform the **Install**.

Set the **Game Play Type** to "Home" Rules. *Programming varies and is subject to change.*



### Install Novelty

To initiate, from the **INSTALLS MENU**, select the "NOV" *Icon*. The Dot Matrix Display will indicate the **INSTALL NOVELTY**. Follow the on-screen prompts to perform the **Install**.

\*\*\*\*\* This setting is recommended where local laws restrict certain game features. \*\*\*\*\*

Set the **Game Play Type** to "Restricted" Rules. *Programming varies and is subject to change.*



### Install Add-A-Ball

To initiate, from the **INSTALLS MENU**, select the "A.A.B." *Icon*. The Dot Matrix Display will indicate the **INSTALL ADD-A-BALL**. Follow the on-screen prompts to perform the **Install**.

\*\*\*\*\* This setting is recommended where local laws restrict certain game features. \*\*\*\*\*

Set the **Game Play Type** to "Restricted" Rules. *Programming varies and is subject to change.*

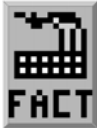

### Install Factory

To initiate, from the **INSTALLS MENU**, select the "FACT" *Icon*. The Dot Matrix Display will indicate the **INSTALL FACTORY**. Follow the on-screen prompts to perform the **Install**. **CAUTION!** All **Standard and Feature Adjustments** which were changed in the **INSTALLS MENU** or **ADJUSTMENTS MENU** are returned to the **Factory Defaults** (as indicated in the Dot Display in the **ADJUSTMENTS MENU**). *Note: To perform a complete **Factory Reset**, GO TO THE RESETS MENU. Escape back to the UTILITIES MENU, select the "RESET" Icon, then select the "FACT" Icon in the RESETS MENU (review the end of this chapter, Page 40, Reset Factory Settings).*

**INSTALLS MENU** continued on the next page.



# Overview of Factory Defaults which change with a Particular Install

## STANDARD ADJUSTMENTS (ADJUSTMENTS NOT AFFECTED ARE NOT SHOWN) ▼

Nr.	STANDARD ADJUSTMENT NAME	INSTALL FACTORY	INSTALL MEDIUM *	INSTALL 3-BALL	INSTALL 5-BALL	INSTALL COMPETITION	INSTALL DIRECTOR'S CUT *	INSTALL HOME PLAY *	INSTALL NOVELTY	INSTALL ADD-A-BALL
1	REPLAY TYPE	AUTO		AUTO	AUTO	AUTO			NONE	AUTO
2	REPLAY PERCENTAGE	10%		10%	10%	10%				10%
3	REPLAY AWARD	CREDIT		CREDIT	CREDIT	CREDIT				EX. BALL
4	REPLAY LEVELS	1		1	1	1				1
5	AUTO REPLAY START	20,000,000		20,000,000	20,000,000	20,000,000				20,000,000
6	DYNAMIC REPLAY START	60,000,000								
7	REPLAY LEVEL #1	15,000,000								
8	REPLAY LEVEL #2	30,000,000								
9	REPLAY LEVEL #3	45,000,000								
10	REPLAY LEVEL #4	60,000,000								
11	REPLAY BOOST	YES		YES	YES	YES				YES
12	SPECIAL LIMIT	1		1	1	1			1	1
13	SPECIAL PERCENTAGE	10%		10%	10%	10%			10%	10%
14	SPECIAL AWARD	CREDIT		CREDIT	CREDIT	CREDIT			POINTS	EX. BALL
15	FREE GAME LIMIT	5		5	5	5			NO FREE...	NO FREE...
16	EXTRA BALL LIMIT	5		5	5	5			NO EXTRA	9
17	EX. BALL PERCENTAGE	25%		25%	25%	25%			25%	25%
18	GAME PRICING	USA 5		USA 5	USA 5	USA 5			USA 5	USA 5
19	MATCH PERCENTAGE	9%		9%	9%	9%			OFF	OFF
20	MATCH AWARD	CREDIT		CREDIT	CREDIT	CREDIT			CREDIT	CREDIT
21	BALLS PER GAME	3		3	5	3			3	3
22	TILT WARNINGS	2		2	2	2			2	2
23	CREDIT LIMIT	30		30	30	30			30	30
24	ALLOW HIGH SCORES	YES		YES	YES	YES			YES	YES
25	HIGH SCORE AWARD	CREDIT		CREDIT	CREDIT	CREDIT			CREDIT	CREDIT
26	GRND CHMPN AWARDS	1		1	1	1			0	0
27	HIGH SCORE #1 AWARDS	1		1	1	1			0	0
28	HIGH SCORE #2 AWARDS	0		0	0	0			0	0
29	HIGH SCORE #3 AWARDS	0		0	0	0			0	0
30	HIGH SCORE #4 AWARDS	0		0	0	0			0	0
31	GRND CHMPN SCORE	75,000,000		75,000,000	75,000,000	75,000,000			75,000,000	75,000,000
32	HIGH SCORE #1	55,000,000		55,000,000	55,000,000	55,000,000			55,000,000	55,000,000
33	HIGH SCORE #2	40,000,000		40,000,000	40,000,000	40,000,000			40,000,000	40,000,000
34	HIGH SCORE #3	30,000,000		30,000,000	30,000,000	30,000,000			30,000,000	30,000,000
35	HIGH SCORE #4	25,000,000		25,000,000	25,000,000	25,000,000			25,000,000	25,000,000
36	HSTD INITIALS	3 INITIALS		3 INITIALS	3 INITIALS	3 INITIALS			3 INITIALS	3 INITIALS
37	HSTD RESET COUNT	2000		2000	2000	2000			2000	2000
38	FREE PLAY	NO		NO	NO	YES			NO	NO
40	PLAYER LANG. SELECT	YES		YES	YES	NO			YES	YES
45	GAME RESTART	YES		YES	YES	NO			YES	YES
48	BALL SAVE TIME	0:05		0:05	0:05	0:05			0:05	0:05
49	TIMED PLUNGER	OFF		OFF	OFF	OFF			OFF	OFF
50	FLIPPER BALL LAUNCH	OFF		OFF	OFF	OFF			OFF	OFF
51	COINDOOR BALL SAVER	NO		NO	NO	YES			NO	NO
52	COMPETITION MODE	NO		NO	NO	YES			NO	NO
53	CONSOLATION BALL	YES		YES	YES	YES			YES	YES
57	PLAYER COMPETITION	YES		YES	YES	YES			YES	YES
58	TEAM SCORES	NO		NO	NO	NO			NO	NO
63	LOST BALL RECOVERY	YES		YES	YES	NO			YES	YES

\* Note: Currently, no Standard Adjustments are changed if Install EXTRA EASY, ... EASY, MEDIUM, HARD, EXTRA HARD, Install HOME PLAY or Install DIRECTOR'S CUT is performed.

SOME INSTALLS MAY CHANGE ADJUSTMENTS NOT NOTED ABOVE WITH FUTURE UPGRADES. YOU CAN ALSO REVIEW OR CHANGE ANY ADJUSTMENT IN THE ADJUSTMENTS MENU (SEE SECTION 3, CHAPTER 4). ADJUSTMENTS WHICH WERE CHANGED ARE NOT NOTED WITH FACTORY DEFAULT ON THE BOTTOM LINE OF THE DOT DISPLAY. THE SETTINGS HIGHLIGHTED ABOVE WILL OVERRIDE ANY MANUAL CHANGES MADE IN THE ADJUSTMENTS MENU.

STANDARD ADJUSTMENTS NOT LISTED ABOVE WHICH NEVER CHANGE WITH ANY INSTALL : 39, 41-44, 46-47, 54-56 & 59-62  
**INSTALLS MENU continued on the next page.**



# Overview of Factory Defaults which change with a Particular Install

## FEATURE ADJUSTMENTS (ADJUSTMENTS NOT AFFECTED ARE NOT SHOWN) ▼

Nr.	FEATURE ADJUSTMENT NAME	INSTALL FACTORY	INSTALL EXTRA EASY	INSTALL EASY	INSTALL MEDIUM or 3-BALL	INSTALL HARD	INSTALL EXTRA HARD	INSTALL 5-BALL	INSTALL COMPETITION	INSTALL DIRECTOR'S CUT	INSTALL HOME PLAY *
1	SINK SHIP DIFFICULTY	MEDIUM	EXTRA EASY	EASY	MEDIUM	HARD	EXTRA HARD	HARD	SEE INSTALL HARD ▲ ▼	MEDIUM	SEE INSTALL MEDIUM ▲ ▼
2	KRAKEN DIFFICULTY	MEDIUM	EXTRA EASY	EASY	MEDIUM	HARD	EXTRA HARD	HARD		MEDIUM	
3	PORT ROYAL DIFFICULTY	MEDIUM	EASY	EASY	MEDIUM	HARD	HARD	HARD		MEDIUM	
4	DAVY JONES DIFFICULTY	MEDIUM	EASY	EASY	MEDIUM	HARD	HARD	HARD		MEDIUM	
5	1ST EXTRA BALL FROM TREASURE	25	15	20	25	40	50	40		20	
6	TREASURES TO NEXT EXTRA BALL	50	30	40	50	70	80	70		40	
7	CHEST DIFFICULTY	MEDIUM	EASY	EASY	MEDIUM	HARD	HARD	HARD		MEDIUM	
8	PARLAY DIFFICULTY	MEDIUM	EASY	EASY	MEDIUM	HARD	HARD	HARD		MEDIUM	
9	BROADSIDE DIFFICULTY	MEDIUM	EXTRA EASY	EASY	MEDIUM	HARD	EXTRA HARD	HARD		MEDIUM	
10	HEART MULTIBALL DIFFICULTY	MEDIUM	EXTRA EASY	EASY	MEDIUM	MEDIUM	MEDIUM	MEDIUM		MEDIUM	
11	PIRATE KING	25			25						
12	GAUNTLET CHAMPION 1	15			15						
13	GAUNTLET CHAMPION 2	10			10						
14	GAUNTLET CHAMPION 3	05			05						

\* Note: Currently, no Feature Adjustments are changed if Install **COMPETITION**, Install **HOME PLAY**, Install **NOVELTY** or Install **ADD-A-BALL** is performed.

SOME INSTALLS MAY CHANGE ADJUSTMENTS NOT NOTED ABOVE WITH FUTURE UPGRADES. YOU CAN ALSO REVIEW OR CHANGE ANY ADJUSTMENT IN THE **ADJUSTMENTS MENU** (SEE SECTION 3, CHAPTER 4). ADJUSTMENTS WHICH WERE CHANGED **ARE NOT NOTED** WITH **FACTORY DEFAULT** ON THE BOTTOM LINE OF THE DOT DISPLAY. THE SETTINGS HIGHLIGHTED ABOVE WILL OVERRIDE ANY MANUAL CHANGES MADE IN THE ADJUSTMENTS MENU.

FEATURE ADJUSTMENTS LISTED ABOVE WHICH NEVER CHANGE WITH ANY INSTALL : **11 – 14**

**Sec. 3: Go To Utilities**





## Enter Custom Message

To initiate, from the **UTILITIES MENU**, select the "ABCD CUST MSG" *Icon*. The **SET CUSTOM MESSAGE** (a short-cut for Standard Adjustment **41, Custom Message**) provides an opportunity to have a text message appear in the the **Attract Mode**. Follow the on-screen prompts to complete [ END ].

Remember, use the **GREEN Button** to go [ **BACK** ], exit or escape, the **RED Buttons** to [ **</-** ] MOVE LEFT / CHOOSE NEXT [ **+/>** ] MOVE RIGHT / CHOOSE PREVIOUS, and the **BLACK Button** to [ **SELECT** ] as 'OK'.



## Set Custom Pricing

To initiate, from the **UTILITIES MENU**, select the "PRIC" *Icon*. The **CUSTOM PRICING MENU** (a short-cut for Standard Adjustment **18, Game Pricing**, and setting selected is **CUSTOM**) provides an opportunity to set **Custom Pricing**.

**Note ! MONETARY AMOUNT MUST BE SELECTED FIRST!** Press [ **BACK** ] to - DECREASE or [ **SELECT** ] to + INCREASE the [ **< \$ >** ] monetary amount (e.g. look at the right side of the display from **\$0.25** to **\$0.50** ). Press [ **</-** ] to - DECREASE or [ **+/>** ] to + INCREASE the **credit quantity** (e.g. look at the left side of the display from **0 CREDITS AT:** to **1 CREDIT AT:**).

**IF EXAMPLE CUSTOM PRICING SETTING DESIRED IS :**

1 Play for \$0.50, 3 Plays for \$1.00 and 7 Plays for \$2.00

**THEN YOU WILL NEED TO PERFORM THE FOLLOWING :**

### REMINDER

In these menus:

Press [ **BACK** ] to - DECREASE [ **< \$** ]

Press [ **SELECT** ] to + INCREASE [ **\$ >** ]

**Step 1** The starting display appears as below if no prior **Custom Pricing** was installed.



**Step 2** Press [ **SELECT** ] to + INCREASE to **\$0.50**. Press [ **+/>** ] to + INCREASE to 1 CREDIT AT:

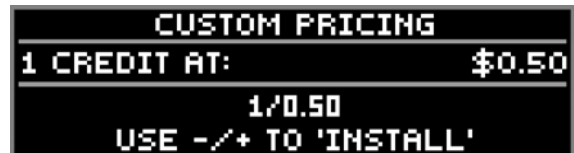

**Step 3** Press [ **SELECT** ] to + INCREASE to **\$1.00**. Press [ **+/>** ] to + INCREASE to 2 CREDITS AT:



**Step 4** Press [ **SELECT** ] to + INCREASE to **\$2.00**. Press [ **+/>** ] to + INCREASE to 4 CREDITS AT:

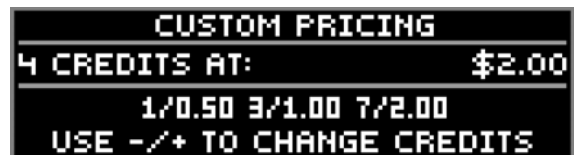

**Step 5** Press [ **SELECT** ] to + INCREASE the amount once (example = \$2.25). Press [ **</-** ] once ...

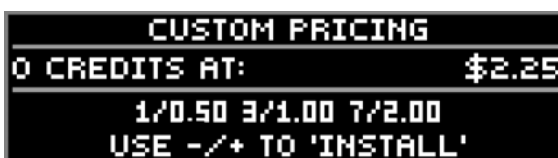

**Step 6** Press [ **SELECT** ] to **INSTALL**. Press [ **</-** ]/[ **+/>** ] or [ **BACK** ] to edit.



... or press [ **+/>** ] eleven times until **INSTALL** appears.

**Step 7** Press [ **SELECT** ], press [ **BACK** ] twice to exit the **SERVICE MENU** with your **Custom Pricing** installed.



To correct or make new changes, reenter, which brings you to **Step 6**. Press [ **BACK** ] repeatedly until the monetary amount shown is the desired amount and then continue following the above steps with your new or corrected settings. *If you are still having difficulty or if you have any questions, please call Technical Support 800-542-5377 or 708-345-7700, option 1.*





## Set Date / Time

To initiate, from the **UTILITIES MENU**, select the "TIME" *Icon*. The **SET TIME MENU** appears with the **MONTH** flashing. Setting the date and time is required for 'Data Dumps' and Tournament Start and End Dates. If the setting of Standard Adjustment **61, Time Format**, is set to **12-HOUR** (*Factory Default*) the time will be expressed in the **AM / PM format**. If Standard Adjustment **61, Time Format**, is set to **24-HOUR** the time will be expressed in the **24-hour format**.



## Go To Resets Menu

To initiate, from the **UTILITIES MENU**, select the "RESET" *Icon*. The **RESETS MENU** provides six (6) functions to reset *only the Coin Audits*, reset *only the Game Audits*, reset *only the Grand Champion Score*, reset *only the High Score(s)*, reset *only the paid Credits (includes Service Credits)* or to reset **ALL DATA** back to the **Factory Default Settings**.



### Reset Coin Audits

To initiate, from the **RESET MENU**, select the "COIN" *Icon*. **⚠ ONLY the Coin Audits** [ Earnings Audits **5-12** ], will be reset to zero (0), *Factory Default Settings*. Follow the on-screen prompts to perform the **Reset**.



### Reset Game Audits

To initiate, from the **RESET MENU**, select the "AUD" *Icon*. **⚠ ONLY the Game Audits** [ Earnings Audits **1-4**, Standard Audits **1-59** and Feature Audits **1-XX\*** ], will be reset to zero (0), *Factory Default Settings*. Follow the on-screen prompts to perform the **Reset**. \*varies per game title.



### Reset Grand Champion (Score)

To initiate, from the **RESET MENU**, select the "GC" *Icon*. **⚠ ONLY the Grand Champion Score** [ adjustable via Standard Adjustment **31** ], will be reset to *Factory Default Setting*. Follow the on-screen prompts to perform the **Reset**.



### Reset High Scores

To initiate, from the **RESET MENU**, select the "HSTD" *Icon*. **⚠ ONLY the High Score(s)** [adjustable via Standard Adjustments **32-35** ], will be reset to *Factory Default Setting(s)*. Follow the on-screen prompts to perform the **Reset**. **Note:** *High Scores (but not Grand Champion Score) are reset automatically every 2,000 games (Factory Default Setting) [adjustable via Standard Adjustment **37, HSTD Reset Count** ]*.



### Reset Credits

To initiate, from the **RESET MENU**, select the "CRED" *Icon*. **⚠ ONLY the Credits (includes Service Credits)** [ adjustable via Standard Adjustment **23, Credit Limit** ], will be reset to zero (0), *Factory Default Settings*. Follow the on-screen prompts to perform the **Reset**.



### Reset Factory Settings

To initiate, from the **RESET MENU**, select the "FACT" *Icon*. **⚠ ALL GAME DATA IS RESET!** (*with the exception of Earnings Audit **13**, Software Meter*). **NOTE: IF YOU HAD SET-UP CUSTOM PRICING OR HAD CHANGED ANY ADJUSTMENTS OR PERFORMED INSTALLS, IT IS SUGGESTED TO WRITE DOWN YOUR CHANGES PRIOR TO THE FACTORY RESET.** Follow the on-screen prompts to perform the **Reset**.



## Go To USB Menu

To initiate, from the **UTILITIES MENU**, select the "USB" *Icon*. The **USB MENU** provides three (3) functions to download game data, update your game code or backup your code onto a USB Memory Stick. *Review the inside cover for information on how to update your game code.*



### Dump to USB Memory Stick

To initiate, from the **USB MENU**, select the "DUMP" *Icon*. Follow the on-screen prompts to perform a **Data Dump** (download).



### Update Game Code

To initiate, from the **USB MENU**, select the "UPDT" *Icon*. Follow the on-screen prompts *or review the inside cover for more information.*



### Backup to USB Memory Stick

To initiate, from the **USB MENU**, select the "BKUP" *Icon*. Follow the on-screen prompts to perform a **Backup** (game code only). This backup feature does not retain adjustments and/or settings changes made.







To initiate, from the **MAIN MENU**, select the "TOUR" *Icon*. The **TOURNAMENT MENU** provides ways to quickly and easily start and stop a tournament. Also, tournament data can be viewed (*audits, prize info, etc.*).

All **TOURNAMENT MENU** *Icons* and their usages are explained throughout this chapter in the same order as seen in the Dot Matrix Display. **NOTE:** Depending on Game Type, Version, selections made, Dip Switch settings, location and/or areas, some *Icons* may appear non-functional or may not appear at all. *Icons and/or functions, order and operation are subject to change.*

In displays where changes can be made or to perform a function, use the **GREEN Button** to go [ **BACK** ], exit or escape, the **RED Buttons** to [ **</-** ] HIGHLIGHT PREVIOUS or DECREASE / [ **+ / >** ] HIGHLIGHT NEXT or INCREASE to highlight the desired option, and the **BLACK Button** to [ **SELECT** ] it or activate.



## Start Tournament

To initiate, from the **TOURNAMENT MENU**, select the "STRT" *Icon*. The **START TOURNAMENT MENU** allows the operator to start a tournament. Select **QUICK START** or **CUSTOM** Tournament Start. For the first time Tournament Set-Up, it is recommended to select **CUSTOM**. Follow the on-screen prompts.

After completion of all options in **QUICK START** or **CUSTOM**, the Tournament is started, the **START TOURNAMENT MENU** is exited and returns to the **TOURNAMENT MENU**.

### QUICK START :

Increase or decrease the: • **DAYS, HOURS and MINUTES** • **PRIZE POOL \$ (DOLLAR) and ¢ (CENT) AMOUNT**  
• **INCREMENT THE PRIZE POOL PER PLAY INCREASES \$ and ¢ AMOUNT**

### CUSTOM START :

- Confirm the current date and time (*if it was not set previous via the UTILITIES MENU it can be set-up in this display as well*). Enter the **MONTH, DAY, YEAR** and **TIME**
- Choose the Tournament **Start Date: MONTH, DAY, YEAR** and **TIME**
- Choose the Tournament **End Date: MONTH, DAY, YEAR** and **TIME**
- Choose the **CREDITS** per play desired (01-10). Set the maximum number of *Credits* that may be accumulated per game. **Note:** *The current pricing is displayed; to change pricing GO TO THE ADJUSTMENTS MENU.*

Increase or decrease the: • **PRIZE POOL \$ (DOLLAR) and ¢ (CENT) AMOUNT**  
• **INCREMENT THE PRIZE POOL PER PLAY INCREASES \$ and ¢ AMOUNT**  
• **MAXIMUM (CAP) PRIZE POOL \$ and ¢ AMOUNT.**

- Increase or decrease the number of **PRIZES** (01-05 **HIGH SCORE**; 02-05 **B'N'W**). Set the maximum # of *Prize Positions* to be awarded during a Tournament. **Selections are as follows** (*% distribution cannot be changed*):

		HIGH SCORE:		BUMP N' WIN :	
Set to 01	1 Winner	100%	(1) Prize Pool	Cannot set to 01. Minimum of 2 winners required.	
Set to 02	2 Winners	65%	(1) 35% (2)	Set to 02	2 Winners 65% (1) 35% (2)
Set to 03	3 Winners	50%	(1) 30% (2) 20% (3)	Set to 03	3 Winners 50% (1) 25% (2) 25% (3)
Set to 04	4 Winners	50%	(1) 25% (2) 15% (3) 10% (4)	Set to 04	4 Winners 40% (1) 20% (2) 20% (3) 20% (4)
Set to 05	5 Winners	50%	(1) 20% (2) 15% (3) 10% (4) 5% (5)	Set to 05	5 Winners 40% (1) 15% (2) 15% (3) 15% (4) 15% (5)

- Select the **AWARD TYPE** (**CASH, POINTS, PRIZE, TICKETS** or **NONE**). Select **CASH** for the displays to represent the Prize Pool amount (*based on Jackpot Base and Max.*) in **\$Dollars**. Select **POINTS** for the display to represent the Prize Pool amount in **Points**. Select **PRIZE**, if applicable. Select **TICKET** for the display to represent the Prize Pool amount in **Tickets**. Select **NONE NOTTO** represent anything.

*Custom Start continued on the next page.*



## CUSTOM START Continued.

The following option is available only if **CASH** was selected as the **AWARD TYPE**.

- Select the option to **SHOW PLAYER CASH** (YES or NO). Select **YES** for the display to represent the >>> **previous** <<< Tournament Winners & Cash amount (or Points, Prizes, etc.) will show in the **Attract Mode**.
- Select the kind of **TOURNAMENT** desired (BUMP 'N' WIN or HIGH SCORE).

The following options are available only if **BUMP 'N' WIN** was selected as the **TOURNAMENT TYPE**.

- Select or confirm the **BASE POINT AMOUNT** (00 or 1,000,000 – 4,294,967,295 increments of 1,000,000).
- Select or confirm the **RANGE AMOUNT** (00 or 1,000,000 – 4,294,967,295 increments of 1,000,000).
- Select the **BALLS** per game (1 – 10).



## STOP TOURNAMENT

To initiate, from the **TOURNAMENT MENU**, select the "STOP" *Icon*. The **STOP TOURNAMENT MENU** allows the operator to stop a tournament. **Note:** This *Icon* only appears if a Tournament was set-up and is running (in place of the Start *Icon*).

### STOP TOURNAMENT ARE YOU SURE?

- Use the **BLACK Button** to [ **SELECT** ] to confirm. Press the **BLACK Button** again to continue.

The **STOP TOURNAMENT MENU** is exited and returns to the **TOURNAMENT MENU**.



## VIEW TOURNAMENT DATA

To initiate, from the **TOURNAMENT MENU**, select the "DATA" *Icon*. If no data is available, the display will indicate NO PREVIOUS DATA. Press the **GREEN Button** to escape [ **BACK** ] to the **TOURNAMENT MENU**.



## TOURNAMENT AUDITS [ #1 – #14 ]

To initiate, from the **TOURNAMENT MENU**, select the "AUD" *Icon*. The Dot Matrix Display will indicate the *audit number (in this group)*, *audit name* and the *audit total or value*. The current audit will remain on the display until the next audit is viewed or when this sub-menu is exited.

- |    |   |
|----|---|
| 01 | <b>TOTAL PLAYS</b> : Total number of <i>Regular</i> and <i>Tournament Games</i> played while a <i>Tournament</i> is in progress. This total is derived by adding the below <i>Tournament Audit 02</i> with <b>Regular Plays</b> . |
| 02 | <b>TOURNAMENT PLAYS</b> : Total number of <i>Tournament Games</i> played while a <i>Tournament</i> is in progress.  |
| 03 | <b>TOTAL QUALIFYING PLAYS</b> : Total number of times a player qualified ( <i>invited to enter name</i> ).  |
| 04 | <b>TOTAL GAME EARNINGS</b> : Total Gross Earnings <i>accepted</i> , while a <i>Tournament</i> is active ( <i>in progress</i> ).   |
| 05 | <b>TOTAL TOUR. EARNINGS</b> : <i>Tournament Earnings (Audit 04 less Reg. Game Earnings)</i> while a <i>Tournament</i> is in progress.   |
| 06 | <b>JACKPOT (PRIZE POOL TOTAL)</b> : Total Prize Pool ( <i>Jackpot</i> ) Amount to be paid out while a <i>Tournament</i> is in progress.   |
| 07 | <b>NET EARNINGS</b> : Provides the total Net Earnings ( <i>Gross Earnings less Prize Pool</i> ) while a <i>Tournament</i> is active ( <i>in progress</i> ).   |
| 08 | <b>ACCUM. TOTAL PLAYS</b> : Accumulative total amount of <i>Regular &amp; Tour. Games</i> played since the first <i>Tournament</i> was played.  |
| 09 | <b>ACCUM. TOUR. PLAYS</b> : Accumulative total amount of <i>Tournament Games</i> played since the first <i>Tournament</i> was played.   |
| 10 | <b>ACCUM. QUALIFYING PLAYS</b> : Accumulative total number of times a player qualified ( <i>invited to enter name</i> ).  |
| 11 | <b>ACCUM. EARNINGS</b> : Total Gross Earnings <i>accepted</i> , since the first <i>Tournament</i> was played.   |
| 12 | <b>ACCUM. TOUR EARNINGS</b> : Accumulative total <i>Tournament Game Earnings</i> since the first <i>Tournament</i> was played.  |
| 13 | <b>ACCUM. JACKPOT</b> : Accumulative total of Prize Pool ( <i>Jackpot</i> ) Amounts paid out since the 1st <i>Tourn.</i> was played.  |
| 14 | <b># TOURNAMENTS</b> : Number of <i>Tournaments (not individual Tournament Games)</i> since the first <i>Tournament</i> was played.   |



## SIGN MESSAGES A-B

To initiate, from the **TOURNAMENT MENU**, select the "A-B TEXT" *Icon*. *At time of print, menu non-functional. If made available in future code updates, this menu will allow the operator to display "Location" and "Prize" Messages.* Follow the on-screen prompts to complete [ **END** ].

Remember, use the **GREEN Button** to go [ **BACK** ], exit or escape, the **RED Buttons** to [ **< / -** ] MOVE LEFT / CHOOSE NEXT [ **+ / >** ] MOVE RIGHT / CHOOSE PREVIOUS, and the **BLACK Button** to [ **SELECT** ] as 'OK'.



# Parts Identification & Location (The Pink Pages)

## Table of Contents for Section 4, Chapter 1 of 2

<b>Table of Contents for Section 4, Chapter 1</b> .....	<b>43</b>
<b>Backbox [ S.A.M. System ] - Parts</b> □ .....	<b>44 – 45</b>
▷ Backbox & Tournament Header Sign Front Views ▷ Backbox Parts Table ▷ Backglass Parts Table	
<b>Speaker Panel [ S.A.M. System ] - Parts</b> □ .....	<b>45</b>
▷ Speaker Panel Side View ▷ Speaker Panel Parts Table	
<b>Cabinet - Parts</b> ■ <b>&amp; Switches</b> □ .....	<b>46 – 47</b>
▷ Cabinet Inside Views ▷ Cabinet Parts & Switches Table	
<b>Playfield Top - Miscellaneous Parts</b> □ <b>&amp; Brackets</b> ■ .....	<b>48</b>
▷ Playfield Location & Bottom Arch Drawings ▷ Misc. Parts (Above) Table ▷ Misc. Brackets (Above) Table	
<b>Playfield Bottom - Miscellaneous Parts</b> ■ <b>&amp; Brackets</b> ■ .....	<b>49</b>
▷ Playfield & Back Panel Location Drawings ▷ Misc. Parts (Below) Table ▷ Misc. Brackets (Below) Table	
<b>Playfield Top - Switches (Above)</b> □ .....	<b>50</b>
▷ Playfield Location Drawing	
<b>Playfield Top - Switches (Below)</b> ■ .....	<b>51</b>
▷ Playfield Location Drawing	
<b>Playfield Top - Flat Rails</b> □, <b>Wood Rails</b> ■, <b>Ball Guides</b> ■ <b>&amp; Wire Forms</b> ■ .....	<b>52</b>
▷ Playfield Location Drawing ▷ Flat Rails Table ▷ Wood Rails Table ▷ Ball Guides Table ▷ Wire Forms Table	
<b>Playfield Top - Plastics (Screened &amp; Clear) Kit, Decals &amp; Mylar Kits</b> .....	<b>53</b>
▷ Plastic Shape & Decal Art Drawings	
<b>Playfield Top &amp; Bottom - Metal Posts</b> □ <b>&amp; Fin Shank Screws</b> ■ (Actual Size) .....	<b>54 – 55</b>
▷ Metal Posts & Fin Shank Screw Drawings ▷ Metal Posts Table ▷ Fin Shank Screws Table ▷ Playfield Location Drawing	
<b>Playfield Top &amp; Bottom - Nylon Stop, KEPS, Hex, T-, Flange, Pal &amp; Wing Nuts (Actual Size) .....</b>	<b>55</b>
▷ Nylon Stop Nuts Table ▷ Keps Nuts Table ▷ Hex Nuts Table ▷ T-Nuts Table ▷ Flange Nuts Table ▷ Pal Nuts Table	
▷ Wing Nuts Table	
<b>Playfield Top - Hex Spacers</b> □ (Actual Size) .....	<b>56 – 57</b>
▷ Hex Spacers Drawings ▷ Hex Spacers Table ▷ Playfield Location Drawing	
<b>Playfield Top - Plastic Posts &amp; Spacers</b> □ <b>&amp; Metal Spacers</b> ■ .....	<b>58 – 59</b>
▷ Plastic Posts & Spacers Drawings ▷ Plastic Posts & Spacers Table ▷ Playfield Location Drawings	
<b>Playfield Top &amp; Bottom - Rubber Parts</b> ■ <b>&amp; Blue</b> ■ (Rings Actual Size) .....	<b>60 – 61</b>
▷ Rubber Parts Drawings ▷ Rubber Bumper Pads Table ▷ Rubber Bumper Post Sleeves Table ▷ Rubber Rings Table	
▷ Playfield Location Drawings	
<b>Playfield Top &amp; Bottom - Small Bayonet Sockets &amp; Bulbs</b> ■ (Actual Size) .....	<b>62 – 63</b>
▷ Bulbs & Socket Drawings ▷ Bulbs (#44 / LED & #455) Table ▷ Small Bayonet Sockets Table	
<b>Playfield Bottom - Large Bayonet Sockets &amp; Bulbs</b> ■ (Actual Size) .....	<b>63</b>
▷ Bulbs & Socket Drawings ▷ Bulbs (#89) Table ▷ Large Bayonet Sockets Table	
<b>Playfield Top &amp; Bottom - Wedge Base Sockets &amp; Bulbs</b> ■ (Actual Size) .....	<b>64</b>
▷ Bulbs & Socket Drawings ▷ Bulbs (#555 & LED / #906) Table ▷ Wedge Base Sockets Table	



# Backbox [ S.A.M. System ] - Parts

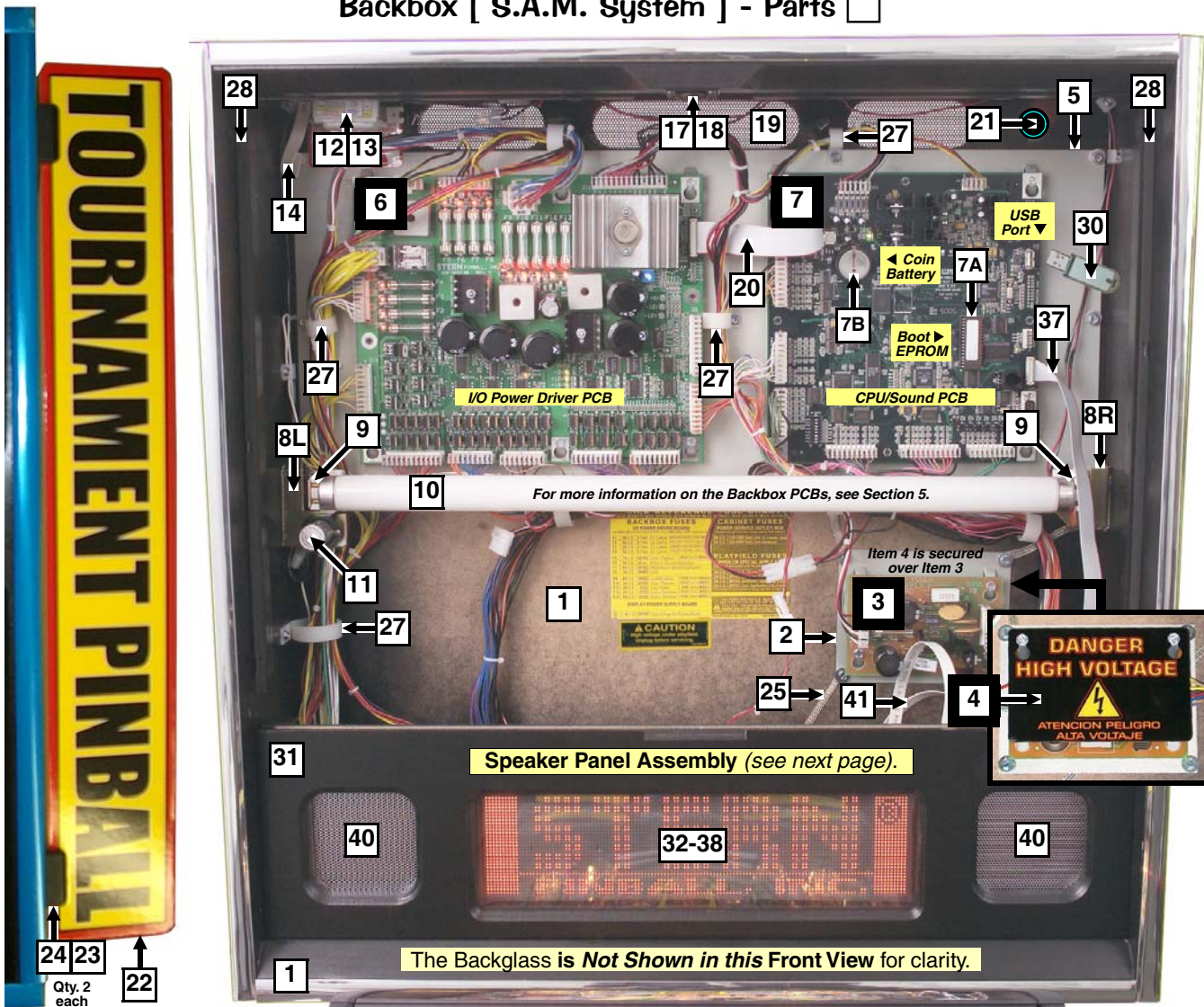

Sec. 4: Parts Id. ...

Nr.	BACKBOX PARTS	QTY.	SPI PART Nr.	Nr.	BACKBOX PARTS	QTY.	SPI PART Nr.
1	Backbox <b>POTC®</b> (No Parts)	1	<b>525-5631-18-92</b>	11	Starter - Fluorescent (FS2 Light)	1	165-5011-01
<i>Item 1 Note: Gold + Black T-Molding is installed and cannot be ordered separately. Fuse Description (820-6384-00) and High Voltage Caution (UL) (820-6082-01) Decals.</i>				11	Starter Base (with leads) [on Item 8L]	1	077-5213-00
2	PCB Metal Mounting Plate [Display]	1	535-9769-00	Item 11 is secured to Item 8L by: #4-40 X 1/2" PPH MS (Sems) Zc. (Qty. 2) (237-5813-00)			
3	Display Power Supply PCB	1	<b>520-5138-00</b>	12	Ballast Mounting Plate	1	535-8657-00
Item 3 is secured to @ bottom by: #8-32 X 3/8" SHWH Swg. (Zinc) (Qty. 2) (237-5975-00)				13	Ballast CU452-W 1/2" Core 120v 60 Hz 13W	1	010-5015-00
4	Plastic Cover [DANGER HIGH VOLTAGE]	1	830-6053-00	Items 12 & 13 are secured to Item 1 by: #6 X 5/8" SHWH AB (Zc) (Qty. 2) (234-5102-04) >>> CAUTION - VERY HOT" Decal (820-6266-00) EU / UK Only : Ballast, 5/8" Core 50/60 Hz (010-5015-01)			
Items 3 & 4 are secured to @ top by: 1-1/4" X 3/8" Plastic Spacer Gray (Qty. 2) (254-5000-05) and #8-32 X 1-3/4" SHWH Ser. (Zinc) (Qty. 2) (237-5975-28)				14	Ground Strap (5")	1	600-5006-05
5	PCB Metal Mounting Plate [I/O+CPU]	1	535-9664-00	15*	Roto Lock Male (on Cabinet)	1	355-5006-01
Items 2 & 5 are secured to Item 1 by: #8 X 1/2" SHWH AB (Zinc) (Qty. 1/hole) (234-5101-00) and #10 Washer 7/32" I.D. X .5" O.D. X 1/16" Thick (Qty. 1/hole) (242-5003-00) Note: Where a Wire Clamp (Item 27) is mounted, a #10 Washer is not required.				16	Roto Lock Female (R2-0002-02)	1	355-5006-02
6	I/O Power Driver PCB [S.A.M. Sys.]	1	<b>520-5249-00</b>	Item 16 is secured by: #10-24 X 1-3/4" CBSN (231-5022-00), #10-24 Keps Nut (Qty. 2) (240-5207-00), #10-24 X 2" CBSN (231-5045-00), #10-24 Keps Nut (240-5207-00) and #10 Washer 7/32" I.D. X .5" O.D. X 1/16" (Qty. 5) (242-5003-00); See opposite next page.			
7	CPU/Sound PCB [S.A.M. System]	1	<b>520-5246-00</b>	17	Lock Mounting Plate	1	535-8128-01
7A: 8MB EPROM #M27C801-100F1 (960-5016-00) Ordering Note: Programmed EPROM (965-BOOT-SAM) 7B: Coin Cell Battery (CR2430 3V) (000-0644-01) For USB Memory Stick Information, see Item 30 on the next page.				18	Lock 5/8" Barrel, 3/4"ø, 1.5" Flat Cam	1	355-5055-00
Items 6 & 7 are secured to Item 5 by: #8-32 X 3/8" HWH MS (Qty. 10) (237-5903-00) and 1/4" Sft. Rtn. Plastic Spacer White (Qty. 5 [I/O] / Qty. 4 [CPU]) (254-5007-05)				Items 17 & 18 are secured by: #8 X 1/2" TP Torx T20 Black (Qty. 4) (237-6173-05)			
8L	Fluorescent Light Bracket (Left Style)	1	535-7739-00	19	Back Vent Grill 2-1/2" X 18"	1	545-5072-02
8R	Fluorescent Light Brckt. (Right Style)	1	535-7739-01	20	Ribbon Cable, 20-Pin (3.5")	1	036-5000-350
Items 8L & 8R are secured to Item 1 by: #10-24 X 1-1/4" Carriage Bolt Square Neck (Qty. 2/per) (231-5012-00), #10-24 Keps Nut (Qty. 2/per) (240-5207-00) and 3/4" X 3" Reinforced Strapping Tape (Qty. 1, sold in 12" length only) (626-5040-00)				Item 20 connects the I/O Pwr. Dvr. PCB to the CPU/Sound PCB; For 14-Pin see next page.			
9	Fluorescent Lamp Holder (Socket)	2	077-5214-01	21	Button Hole Plug (Blk) (Happ #52-6214-00)	1	500-6566-00
Item 9 is secured to Items 8L and 8R by: #6-32 X 5/8" PPH MS (Sems) Zinc (Qty. 1/per) (232-5203-00) Lock-In Fluor. Bulb with Yellow Socket Clip (Qty. 1/per) (545-6271-00)				22	Header Sign TOURNAMENT PINBALL	1	545-6133-00
10	Fluorescent Tube 24" (F20T9CW)	1	165-5061-00	23	Friction Hinge (Black) behind ▲▼	2	390-5053-00
				24	Block / Sign & Hinge Stop (Black)	2	545-6174-00
				Item 22 is sandwiched between Items 23 & 24 through 2 holes on each side. Item 23 is secured to Item 1 by: #8-32 X 3/8" PPH MS Ext. Sems (Zinc) (Qty. 2/per) (232-5301-00) and Item 24 to Items 22-23 by: #8 X 5/8" PPH AB Black (Qty. 2/per) (232-5101-01)			

PARTS TABLE & VIEWS CONTINUED ON THE NEXT PAGE. ▶



## Backbox [ S.A.M. System ] - Parts

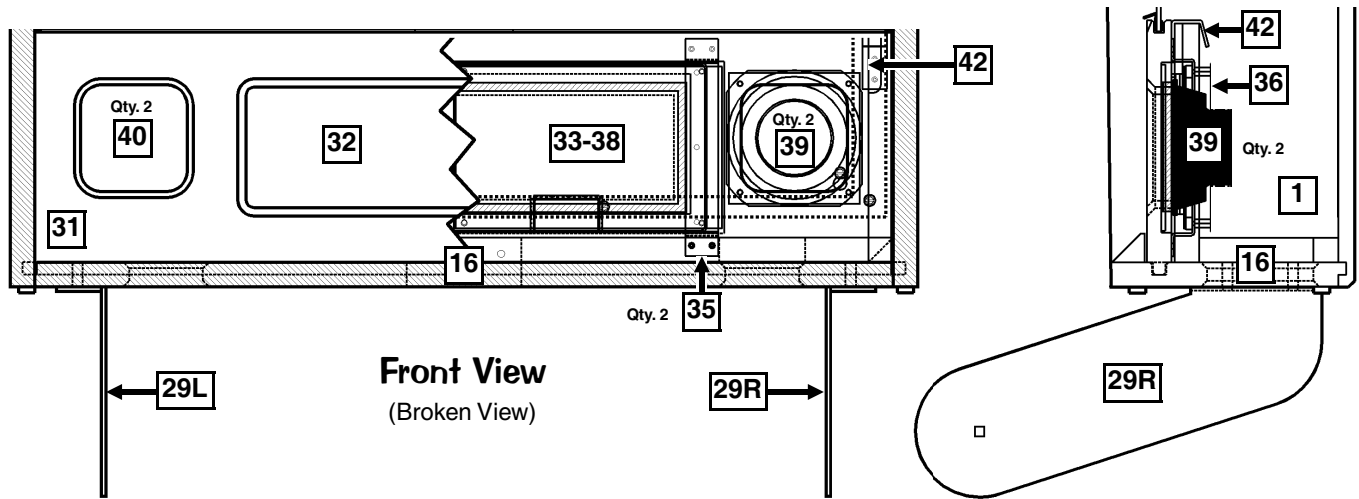

## Speaker Panel [ S.A.M. System ] - Parts

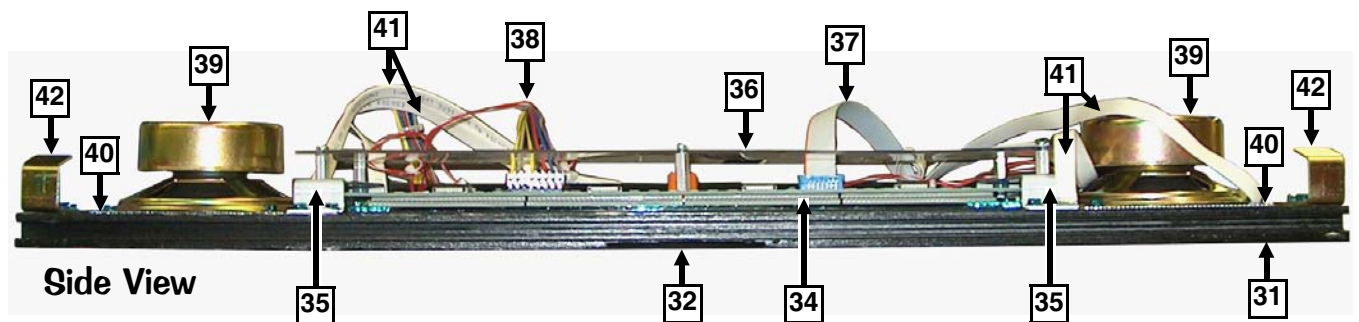

Nr.	BACKBOX PARTS	QTY.	SPI PART Nr.	Nr.	SPEAKER PANEL PARTS	QTY.	SPI PART Nr.
<p>← PARTS TABLE &amp; VIEWS CONTINUED FROM THE PREVIOUS PAGE.</p>							
25	Braided Wire (1-1/2 Feet)	1	600-5001-00	31	Speaker Panel (Black Wood)	1	525-5515-00
Item 25 is secured by: Staple 5/16" (Qty. 23) (631-5000-00)				32	Plastic Shield (Display Front Cover)	1	545-5884-00
26*	Zip Cable Tie (Screw Down Style)	2	040-5005-00	Item 33 is secured to inside Item 31 by: #6 X 3/8" SHWH AB (Zinc) (Qty. 8) (234-5000-00)			
Item 26 is secured @ inside bot. by: #8 X 7/8" PPH AB (Zinc) (Qty. 1/per) (232-5103-00)				33*	Foam 3/16" Thick X 1/4" Wide X 12"	3	626-5026-00
Item 33 is self-adhesive. Located between Items 32-34. Sold in 12" Lengths only.				34	128 X 32 Dot Matrix Display PCB	1	<b>520-5052-00</b>
27	Clamps [Multiple Sizes]	15	040-5000-XX	<p>/// EURO ONLY RoHS /// 128 X 32 DM Pin-LED PCB <b>520-5052-04</b></p> <p>/// EURO ONLY RoHS /// Dot Matrix Pin-LED Bezel <b>545-6281-00</b></p>			
Item 27 secured by: #8 X 1/2" SHWH AB (Zinc) (Qty. 1/per) (234-5101-00)				Item 34 is secured to Item 35 by (at corners): 3/16" X 3/8" Spacer Gray (Qty. 4) (254-5000-18) and #6-32 X 1/2" SHWH Swage (Serr) Zinc (Qty. 4) (237-5976-03)			
For following sizes, replace -XX with: 1/4" Double = -23 (Qty. 5); 1/2" Single = -06 (Qty. 1); 3/4" Single = -08 (Qty. 3); 1" Single = -09 (Qty. 1); 1-1/4" Double = -30 (Qty. 2)				35	Dot Matrix Display Mounting Bracket	2	535-8368-01
28	Foam 3/16" Thick X 1/4" Wide X 12"	3	626-5026-00	Item 35 is secured to Item 31 by: #8 X 5/8" SHWH AB (Green) (Qty. 4/per) (234-5102-04)			
Above Item 28 is self-adhesive. 17.5" strip on each side. Sold in 12" Lengths only.				36	Plastic Shield (Display Back Cover)	1	830-6040-00
29L	Pivot Hinge Left	1	535-7999-00	Item 36 is secured to Item 34 by: 1/2" X 1/4" Hex Spacer #6-32 Tap (Qty. 4) (254-5008-03), 3/4" X 1/4" Hex Spacer #6-32 Tap (Qty. 2) (254-5008-04), #6-32 X 1/4" PPH MS (Sems) Zinc (Qty. 2) (232-5200-00) and #6-32 X 3/8" PPH (Qty. 6) (232-5201-00)			
29R	Pivot Hinge Right	1	535-7999-01	37	Ribbon Cable, 14-Pin (32")	1	036-5260-32
Items 29L-29R are sec'd by: 1/4"-20 X 1-1/4" C.B. Sq. Neck (Qty. 4) (231-5003-00), 1/4"-20 Flange Nut (Qty. 4) (240-5300-00) and Fend Washer 1/4" I.D. X 1" O.D. (Qty. 1) (242-5009-00)				/// EURO ONLY RoHS /// LED Ribbon Cable Filter PCB <b>520-5259-00</b>			
Items 29L-29R are secured to Cabinet by: Spacer Hex Nut 1/2" O.D. - 1/4-20 X 1/2" TD (Black) (Qty. 1/per) (254-5042-00), Nylon Spacer (Black) (Qty. 1/per) (242-5084-00), 1/4-20 X 1/2" Carriage Bolt Sq. Neck (Black) (Qty. 1/per) (231-5072-00), Fend Washer 1/4" I.D. X 1" O.D. (Qty. 1/per) (242-5009-00) and 1/4"-20 Flange Nut (Qty. 1/per) (240-5300-00)				Item 37 (14-Pin) connects the 128 X 32 Dot Matrix Display PCB to the CPU/Sound PCB.			
30*	Memory Stick USB 1.1 [Generic] 128MB	1	970-0128-00	38	Display Cable (Wiring Harness)	1	036-5454-01
Item 30 was not included with your game. Read the inside cover or go on-line for more info. To order with the latest game code copied onto it, add -92 to the Part Nr. (970-0128-00-92). File(s) can be downloaded from our website (Files are 25MB or larger, DSL or Fast Modem recommended). Not all manufacturers of Memory Sticks are compatible with our system. Test it out, if it doesn't work properly, return your purchase and order the memory stick through you local pinball distributor (Stern Pinball Memory Sticks guaranteed compatible). (ASM. REF. 505-6002-92-92, Items 1-42 Only, [29-30 not included in assembly])				/// EURO ONLY RoHS /// LED Display Adapter Harness <b>036-5520-00</b>			
<b>Take Note:</b>				39	Speaker (Shld.) 4" 8Ω #4060CESH-1	2	031-5004-01
* An asterisk ( * ) indicates item(s) are not noted in the pictorials.				Items 39-40 are secured by: #8 X 5/8" SHWH AB (Green) (Qty. 4/per) (234-5102-04)			
				40	Speaker Grill (Brass w/no Artwork)	2	535-8081-03
				41	Ground Strap (25") [ 2 per : Items 35 & 39 ]	4	600-5006-25
				42	Speaker Panel Hook Bracket	2	535-7009-02
				Item 42 is secured by: #8 X 5/8" SHWH AB (Green) (Qty. 2/per) (234-5102-04)			
				(ASM. REF. 515-6888-06, Items 31-42 Only [includes wiring])			

Nr.	BACKGLASS PARTS	QTY.	SPI PART Nr.	Nr.	BACKGLASS PARTS	QTY.	SPI PART Nr.
i*	Clear Backglass 25.906" X 19.187"	1	660-5038-02	iv*	Bottom Plastic Lift Channel - 26-1/16"	1	545-5021-01
ii*	Pirates / Caribbean ® Film Art (#92)	1	830-5292-00	v*	Plastic Edging (Left/Right) - 18-1/8"	2	545-5018-14
iii*	Top Plastic Channel - 26"	1	545-5018-15	Items i-v are secured to Item i by: Taple (Double-Sided), 12" (Qty. 1) (626-5005-00)			
				Note: Only 6" required, sold in 12" lengths only.			
				(ASM. REF. 515-5450-00-92, Items i-v)			



# Cabinet - Parts & Switches

For Backbox Parts see the previous two pages.

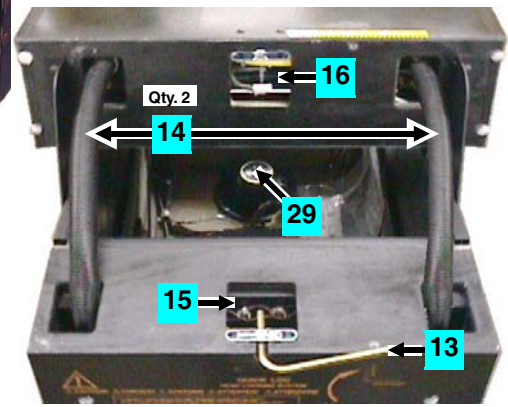

### Take Note:

\* An asterisk (\*) indicates item(s) are not noted in the pictorials.

Legend Note: Items noted with a cyan square are Cabinet Parts. Items noted with a white square are Switches.

Sec. 4: Parts Id. ...

Nr.	CAB. PARTS & SWITCHES	QTY.	SPI PART Nr.	Nr.	CAB. PARTS & SWITCHES	QTY.	SPI PART Nr.
1	Screened Cabinet <b>POTC®</b> (No Parts)		525-5395-15P-92	9L	Side Armor (Left) with Button Guard	1	535-9596-00
2	Black Leg with Leveler Asm.	4	500-5921-50	9R	Side Armor (Right) with Button Guard	1	535-9596-01
Item 2 is secured by: Leg Bolt Back Plate (535-5703-00) and Leg Bolt 3/8" X 16 X 2-1/2" Hex 5/8" Hd. (2/per) (231-5001-01). Leg Leveler ONLY (3/8"-16 X 3") (500-5017-00).				Items 9L & 9R are secured @ front & side by: Pem Stud 1/4 X 1" Flange Head Black (Qty. 1/per) (237-6116-01), 1/4-20 Flange Nut (Qty. 1/per) (240-5300-00) and #8 X 1/2" T20 Tamper Proof Black (Qty. 5/per) (237-6173-05); @ rear (backbox) by: #10-24 X 1" Sq. Neck Carrg. Bolt Black (Qty. 1/per) (231-5021-00) and #10-24 Hex Nut (Qty. 1/per) (240-5202-00)			
3	Start Button (Red Rnd.), Switch + Lamp Asm.	1	500-6388-02	10B*	Front Molding (Black) <u>includes</u> Item 11B	1	500-6882-00-00
Item 3 includes the Switch & Lamp (No Wiring; desolder old wiring where required). Assembly Parts Included : Microswitch (180-5174-00); #555 Wedge Base Clear Bulb (165-5002-00); Note: 1N4004 Diodes (112-5003-00) are used in all Diode applications. Switch Diode required on Switch; Lamp Diode on Terminal Strip; see Sec. 5, Chp. 3, Cabinet Wiring ..., for more information. Diode Terminal Strip 2-Lug (810) Isolated (055-5203-00).				Item 10B includes: Self-Adhesive Foam Rubber 3/8" X 3/16" X 20-3/8" (3") (626-5001-00) Items 10B works with Item 22 (next page) ONLY. *10B to include 11T use 500-6882-01-02			
4	Ball Shooter (Plunger) Assembly	1	500-6146-00-04	11T	Tournament Button (Yellow Square) + Wiring	1	500-6884-00-TK
FOR A BREAKDOWN OF PARTS SEE: Sec. 4, Chp. 2, Drawings for ... Assemblies...				Item 11T includes Switch, Lamp & Wiring (036-5477-99-01). To order separately use: Microswitch No Actuator (180-5119-03); CM86 / C86 6.3V Mini-Wedge Base Clear Bulb (165-5002-01); Read the " Note: " below Item 3, Start Button, regarding diodes.			
5	Flipper Button (Red) Asm. (No Switch)	2	500-5026-32	11B*	Button Plug (Black) for Square Hole	0	500-6883-00
Item 5 is secured by: Pal Nut for Flipper Button (Metal) (Qty. 2/per) (240-5003-01) and is fitted with: O-Ring 11/32" X 7/32" X 1/16" (Qty. 1/per) (545-5850-00)				Item 11B is secured by: #10-24 X 1-3/4" Carr. Bolt Sq. Neck (Qty. 2) (231-5022-00), #10-24 NSN (Qty. 2) (240-5206-00) and #10 Washer 7/32" X 1/2" X 1/16" (Qty. 2) (242-5003-00)			
6S	Flipper Switch Single Assembly	2	500-6889-01	14	Corrugated Tubing Black 1"ø X 2.6' Lg.	1	605-5008-03
Assembly Parts Included : Flipper Switch Stack Single (Paliney Contact) (180-5160-01) and Capacitor - Ceramic .05 Mfd 25 volt (130-5001-00) Item 6S/6D are secured to Cab. by: #6 X 1-1/4 SHWH AB (Zinc) (Qty. 2/per) (237-5959-00)				Above Item 14 covers the Cable Wiring Harnesses going into the Backbox from the Cabinet.			
6D	Flipper Switch Double Assembly [NOT USED]	0	500-6890-01	15	Roto Lock Male (R2-0055-02)	1	355-5006-01
Assembly Parts Included : Flipper Switch Stack Double (Paliney Contact) (180-5164-01) and Capacitor - Ceramic .05 Mfd 25 volt (130-5001-00) Item 6S/6D are secured to Cab. by: #6 X 1-1/4 SHWH AB (Zinc) (Qty. 2/per) (237-5959-00)				Item 15 is secured by: #10-24 X 1-3/4" Carr. Bolt Sq. Neck (Qty. 2) (231-5022-00), #10-24 NSN (Qty. 2) (240-5206-00) and #10 Washer 7/32" X 1/2" X 1/16" (Qty. 2) (242-5003-00)			
7	Rear Glass Channel 20-3/8" Length	1	545-5038-00	16	Roto Lock Female (on Backbox)	1	355-5006-02
8	Plastic Channel 42-5/8" Lg. (Left/Rt.)	2	545-5017-00	PARTS TABLE & VIEWS CONTINUED ON THE NEXT PAGE. ▶			



# Cabinet - Parts & Switches Continued

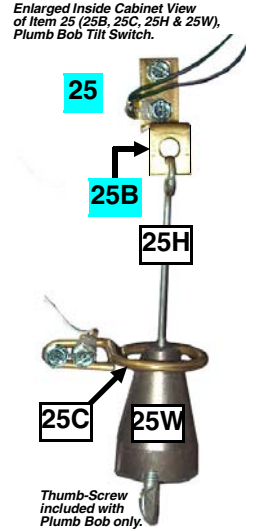
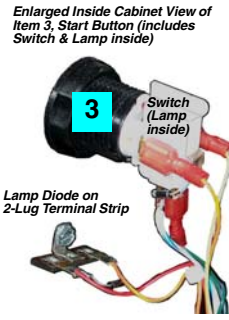
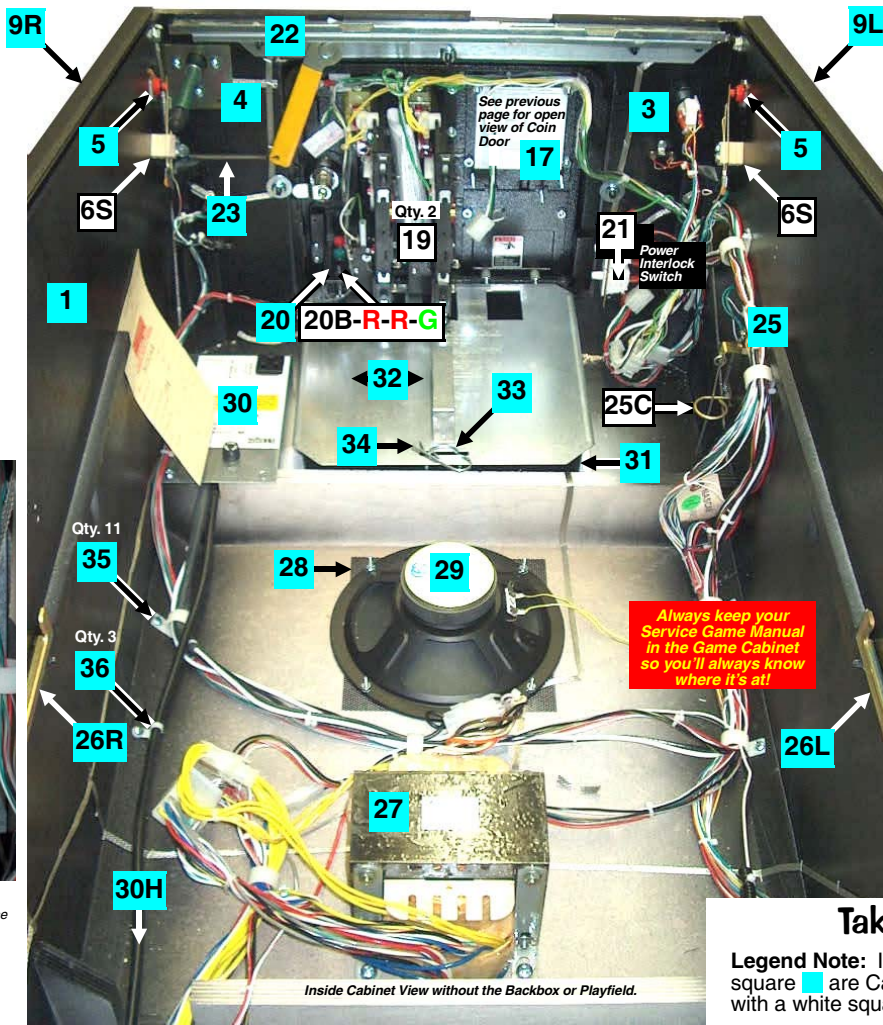
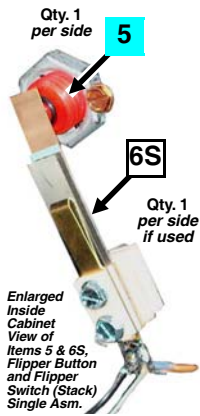

## Take Note:

**Legend Note:** Items noted with a cyan square ■ are Cabinet Parts. Items noted with a white square □ are Switches.

Nr.	CAB. PARTS & SWITCHES	QTY.	SPI PART Nr.	Nr.	CAB. PARTS & SWITCHES	QTY.	SPI PART Nr.
◀ PARTS TABLE & VIEWS CONTINUED FROM THE PREVIOUS PAGE.							
17	Coin Door 2-Cht \$V Up-Stk. 4-Button Bracket	1	501-5018-172	27	Transformer 5.7VAC (with Ballast Winding)	1	010-5012-01
Item 17 is secured by: 1/4"-20 X 1-1/4" Carriage Bolt Square Neck (Qty. 4) (231-5003-00) 1/4"-20 Flange Nut (Qty. 4) (240-5300-00) and Fend Washer 1/4" I.D. X 1" O.D. (Qty. 3) (242-5009-00) Note: For Coin Door other than USA call Technical Support for SPI Part Nr.				Item 27 is secured by: 1/4"-20 X 5/8" PPH MS (Zinc) (Qty. 4) (237-5854-00) and 1/4" Split Lock Washer (Qty. 4) (244-5000-00)			
18	Lock 7/8" Barrel, 435X, Offset Cam	1	355-5021-03K	28	Speaker Grill 7" X 7"	1	545-5072-03
Coin Door Switch (USA) (Happ)				29	Speaker 8" ø Round 8010 4Ω	1	031-5007-00
19	ALT. SW.: 19C: Coin Door Switch (USA) (Coin Control) (180-5024-00) ALT. SW.: 19J: Coin Door Switch (¥ Japan) (180-5091-00)	2	180-5024-01	Items 28 & 29 are secured by: #6-32 X 1-1/4" Fin Shank Screw (Qty. 4) (237-5883-00) and #6-32 Keps Nut (Qty. 4) (240-5008-00)			
20	4-Button Bracket (for Service Menu Buttons)	1	535-6860-04	Power Input Box Assembly			
SWITCH: 20B: Push-Button Service Switch (Black) (180-5192-00) SWITCH: 20R: Push-Button Service Switch (Red) (Qty. 2) (180-5192-02) SWITCH: 20G: Push-Button Service Switch (Green) (180-5192-04)				30A: Power Box (No Parts) Mounting Frame (535-5932-00) 30B*: Line Filter (150-5000-00) 30C*: Varistor* TNR159211KM (Domestic) (150-5001-00) 30D*: Varistor TRM15G431KM (Euro) (150-5002-00) SWITCH: 30E: On/Off Rocker Switch + Bracket Assembly (515-7085-00) 30E incl.: Switch, APEM R2101C5NBB (180-5001-03) + Bracket (535-8318-00) 30F*: Power Box Decal (820-6123-03) 30G: Service Outlet (3-Prong / US) (180-5008-01) 30H: Line Cord 10' ROJ 3" + Ring Terminal Assembly (515-6566-00) 30H incl.: Line Cord 10' ROJ 3" (034-5000-10) + Ring Terminal (055-5031-10) 30I: Recessed (Black) Cup (rear of Cabinet) (545-5122-00) 30J*: Snap Bushing 9/16" (White) (280-5001-01) 30K: Fuse 8 Amp 250V Slo-Blo (Domestic) (200-5000-05) 30K Int'l*: Fuse 5 Amp 250V Slo-Blo (International) (Qty. 2) (200-5003-00) 30L: Fuse Holder (205-5001-00)			
<b>Ordering Note:</b> Securing hardware for switches included. Decal in kit sold separately.				31			
21	Power Interlock-Memory Protect Switch Asm.	1	500-5808-05	31 Cash Box Plastic Bottom			
Assembly Parts Included: Mounting Bracket (535-9794-00), Power Interlock (Playfield) Switch (180-5136-00) and secured by: #8 X 1/2" SHWH AB (Zinc) (Qty. 2) (234-5101-00)				32			
22	Front Molding Lockdown Asm.	1	500-6881-00	32 Cash Box Cover (Validator)			
Item 22 is secured by: #10-24 X 1-1/4" Carr. Bolt (Qty. 2) (231-5012-00), #10-24 Keps Nut (Qty. 2) (240-5207-00), #8 X 1/2" SHWH AB Zinc (Qty. 1) (234-5101-00) and #10 Washer 7/32" I.D. X 1/2" O.D. X 1/16" (Qty. 1) (242-5003-00)				33			
23	Lockdown Spring (connected to handle)	1	265-5008-00	33 Cash Box Lock Bracket (U-Wire)			
24	Grills 2-1/2" X 18" (on Back & Bottom)	2	545-5072-02	Item 33 is secured by: #8 X 3/4 PFH (Zinc) (Qty. 2) (237-5822-00)			
Plumb Bob Tilt Switch Individual Parts Only Ind. Parts Only				34			
25	SWITCH: 25B: Bracket for Hanger Wire (535-5221-00) 25C: Contact Wire Form (535-7563-01) 25H: Hanger Wire (535-5319-02) 25W: Plumb Bob Weight (535-5029-00) (includes Thumb-Screw)			34 Large Hair-Pin Clip			
Item 25B is secured to Cabinet by: #8 X 1/2" SHWH AB (Zinc) (Qty. 4) (234-5101-00)				35			
26L	Slide & Pivot Support Bracket (Left)	1	535-5989-00	35 Clamps [Multiple Sizes]			
26R	Slide & Pivot Support Bracket (Right)	1	535-5990-00	Item 35 is secured to Item 1 by: #8 X 1/2" SHWH AB (Zinc) (Qty. 1/per) (234-5101-00) For following sizes, replace -XX with: 3/4" Single = -08 (Qty. 8); 1-1/2" Single = -10 (Qty. 3)			
Items 26L & 26R are secured by: #10-24 X 1-1/4" Carriage Bolt Square Neck Black (3/per) (231-5012-00) and #10-24 KEPS Nut (3/per) (240-5207-00)				36			
				36 Zip Cable Tie (Screw Down Style)			
				Item 36 is secured by: #8 X 7/8" PPH AB (Zinc) (Qty. 1/per) (232-5103-00)			
				37†			
				37† Meter +12VDC with Bracket Optional			
				0 G-0053-013-102			
† Meters (Diode included) are optional and were not included in this Pinball Machine. Order without the bracket use G-0053-013-102A. More information or Qs? Call Technical Support.							

Sec. 4: Parts Id. ...



# Playfield Top - Miscellaneous Parts and Brackets

Nr.	THE PLAYFIELD	QTY.	SPI PART Nr.
PF	P/F Screened w/ Inserts & NO Parts	1	830-5100-92
	P/F Complete w/ Inserts & ALL Parts	1	505-6004-92-2

Nr.	MISC. PARTS (ABOVE)	QTY.	SPI PART Nr.
1	Arch (Black Metal) [no Forks]	1	535-8392-01
<p><b>Item 1 is secured to Item 9 below by:</b> #10-32 X 5/16" PFH U/C MS (Zinc) (Qty. 2) (237-6013-00) <b>Usage Note:</b> When replacing the Arch, order new replacement Nelson Protect Strips 7-5/8" (not included) (Qty. 2) (545-5212-04; use .02 for 8-9/16" size) For Decals, see <i>Playfield Top - Plastics Kit, Decals &amp; Mylar Kits</i>.</p>			
2	Instruction Card [English/Spanish] POTC®	1	755-5192-12-Y
<p><b>Note:</b> Visit <a href="http://www.sternpinball.com">www.sternpinball.com</a> for a PDF copy of the Game Instruction Card which will also have any translated Instruction Cards made for this game. Find Game Link or Archives. Spanish 755-5192-02-Y; German 755-5192-03-Y; Italian 755-5192-04-Y; French 755-5192-05-Y.</p>			
3A	Coin Card (2-Sided) Yellow Stock	1	755-5400-08-Y
3B	Coin Card (2-Sided) Yellow Stock	1	755-5400-04-Y
<p>For Coin Card views, see below or <b>online</b> : <a href="http://www.sternpinball.com/coinagecards.shtml">http://www.sternpinball.com/coinagecards.shtml</a>  <b>Ordering Note:</b> If this is a non-US Game, Coin Card(s) Part Numbers provided will differ.</p>			

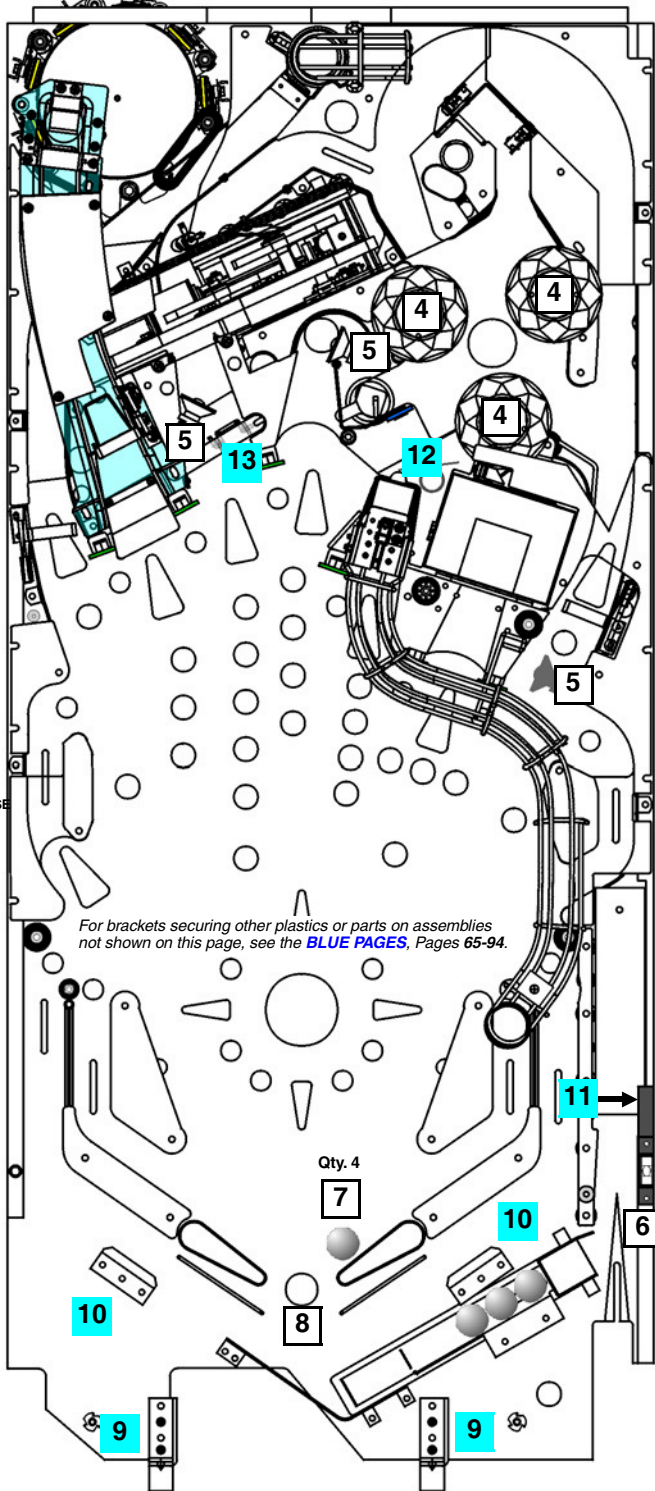
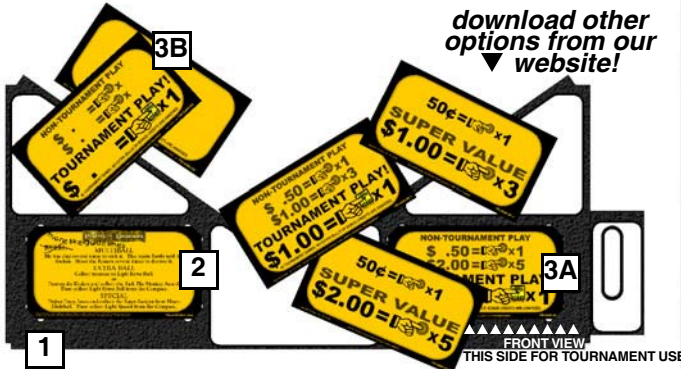

4	Bumper [Pop] Cap (Red)	3	550-5057-02
<p><b>Item 4 is secured by:</b> #4 X 3/4" PRH (Zinc) T-25 (Qty. 2/per) (237-5873-00)</p>			
5	Light Reflector (Silver)	3	545-5409-01
<p><b>Ordering Note:</b> #555 Wedge Base Bulb (165-5002-00) (Qty. 1/per); Wedge Base Socket (Laydown) (077-5026-01) (Qty. 1/per) (views on Page 64)  <b>If mounted on Plastic Spacers (Lights facing the Pirate Ship):</b>                      1/4" X 3/8" Plastic Spacer (254-5000-02) (view on Page 58)  <b>If mounted on Hex Spacer (Light facing the Treasure Chest):</b>                      2" X 1/2" #6-32 Tap (254-5008-07) (view on Page 56)</p>			
6	Bubble Level Assembly	1	500-6815-00
<p><b>Assembly Parts Included:</b> Level .8mm Empire #0224 (545-6001-01) or Level Mount (545-6068-00). <b>Flange secured by:</b> #6-32 X 1/4" PPH MS (no Sems) Zinc (237-5500-00) and #6-32 Keps Nut (240-5008-00) <b>Item 6 is secured to the wood rail by:</b> #6 X 1/2" HWH AB Zinc Red (Qty. 2) (234-5001-02)</p>			
7	Pinball (Steel) 1 1/8" ø	4	260-5000-00
8*	Plug-Cap (3/16") Black Plastic	0	545-5232-01
<p><b>Note:</b> Item 8 should plug hole if a Center Post (@ Drain) is used, then removed.</p>			

For brackets securing other plastics or parts on assemblies not shown on this page, see the **BLUE PAGES**, Pages 65-94.

Nr.	MISC. BRACKETS (ABOVE)	QTY.	SPI PART Nr.
9	Bracket, Playfield Hanger	2	535-8385-00
<p><b>Item 9 is secured to the P/F by:</b> #8-32 X 7/8" HWH MS Zinc (Qty. 2/per) (237-5890-00)</p>			
10	Bracket, Arch Retaining (Hold-Down)	2	535-8394-00
<p><b>Item 10 is secured to the P/F by:</b> #8 X 1/2" SHWH AB (Zinc) (Qty. 3/per) (234-5101-00)</p>			
11	Bracket, Right Ramp Hold-Down	1	535-9960-00
<p><b>Item 11 is secured under Item 6 by:</b> #6 X 1/2" HWH AB Zinc Red (Qty. 2) (234-5001-02)</p>			
12	Bracket, 135° Degree Bend	2	535-8941-06
<p><b>Item 12 is secured by:</b> Rivet, 1/8" ø X 3/16" (Qty. 1/per) (249-5001-00); Where 1/4" is required use: Rivet, 1/8" ø X 1/4" (Qty. 1/per) (249-5003-00)</p>			
13	Bracket, 1-Way Gate 3.5" (See Note)	1	535-9938-00
<p><b>Wire Form for</b> ▲ .719" ID X 1.5" OD X 1" Ht. 1 535-9939-00  <b>Item 13 is secured by:</b> #6-32 X 5/8" PPH MS Ext. Sems (Zinc) (Qty. 2) (232-5203-00) and #6 Washer (Qty. 2) (242-5001-00) <b>Note:</b> Bracket with .944" Space for Wire Form</p>			

## Take Note:

**Legend Note:**  
 Items noted with a white square  are Misc. Parts (Above).  
 Items noted with a cyan square  are Misc. Brackets (Above).

Optional Kits available through your Distributor:

Optional Kits available through your Distributor:

**Pinball Location Maintenance Standard Kit: 502-6002-92**

**Pinball Location Maintenance Deluxe Kit: 502-6003-92**

**Kit includes:** 8 oz. Novus Wax #2 Fine (Red) (675-0003-01), Cloth, Rubber Rings (used above playfield), Bulbs (Bulb quantities vary and is limited to 25 per type), Fuses (5/per type) and 4 Pinballs. **Note:** Quantities, sizes and contents subject to change without notice.

**Deluxe Kit includes:** Pinball Location Maintenance Standard Kit as described plus a quantity of Flipper Rebuild Kits. **Note:** Quantity varies which equals the same quantity of flippers used in this game. **◀ THIS GAME KIT INCLUDES (2) FLIPPER REBUILD KITS ▶**





# Playfield Bottom - Miscellaneous Parts and Brackets

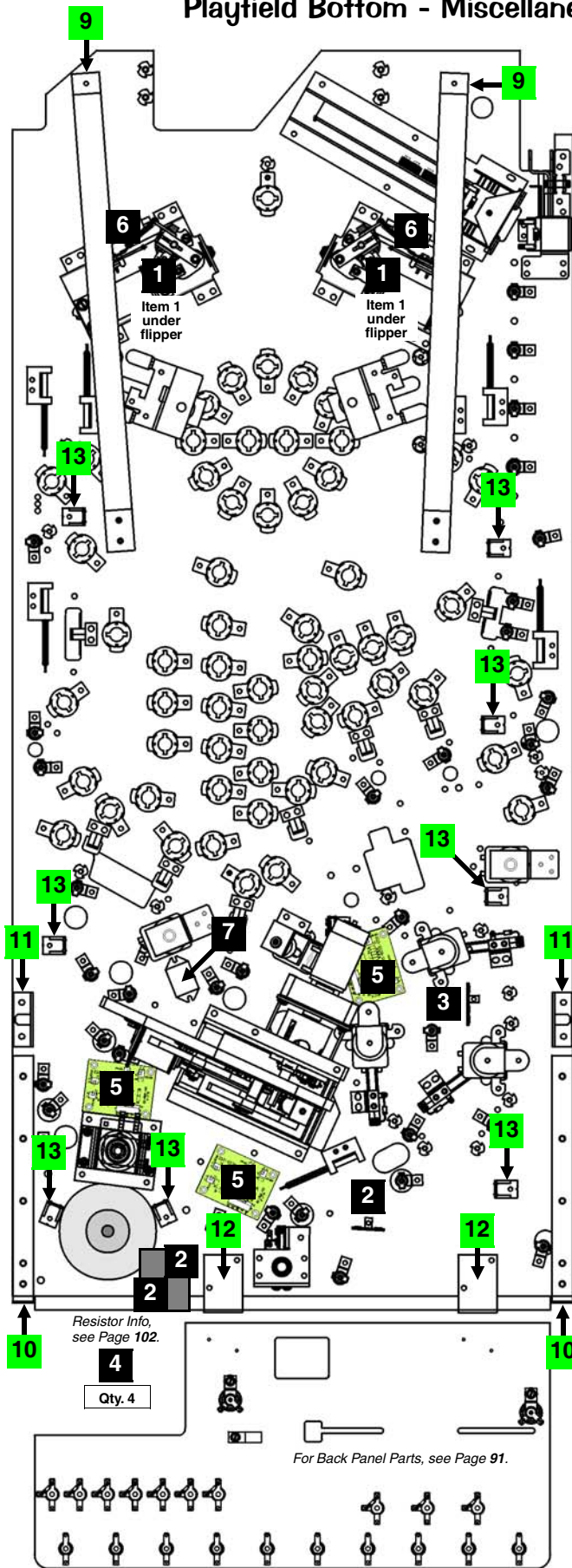

Nr.	THE PLAYFIELD	QTY.	SPI PART Nr.
PF	P/F Screened w/ Inserts & NO Parts	1	830-5100-92
	P/F Complete w/ Inserts & ALL Parts	1	505-6004-92-92

Nr.	MISC. PARTS (BELOW)	QTY.	SPI PART Nr.
1	Insulation Fiche Paper (under Lower Flippers)	2	545-5721-00
2	Diode Terminal Strip 2-Lug (810) Isolated	3	055-5203-00
3	Diode Terminal Strip 3-Lug (813) Isolated	1	055-5204-03
Items 2-3 are secured by: #6 X 3/8 HWH AB Zinc (Qty. 1-2/per) (234-5000-00) Note: 1N4004 Diodes (112-5003-00) are used in all Diode applications. 1N4001 Diodes can be used for Switches and/or Lamps.			
4	Resistor, 10W 5Ω RJ X4 RCD K5-451	4	121-5000-00
Item 4 are soldered to Item 2 (Qty. 2). For more details on Item 4, see Section 5, Chp. 1, Backbox Wiring, Page 97 and Section 5, Chapter 2, Playfield Wiring, Page 102.			
5	PCB, OPTO Amplifier	3	520-5239-01
For more details on Item 5, see Sec. 5, Chapter 4, Printed Circuit Boards, Pages 136-138.			
6	3A 250v Slo-Blo Fuse	2	200-5000-08
	Fuse Clip Holder (Socket)	2	205-5000-01
Item 6 is secured by: #6 X 1/2" PPH AB (Qty. 1/per) (237-5805-00) Note: Item 6, Fuse Clip Holder (Socket) 205-5000-01 is part of a set of 12 (205-5000-12). You can order them as individuals (...-01) or a set of 12 (...-12).			
7	Relay Picker IC + Wiring & Connector	1	511-5024-03
Item 7 is secured by: #6 X 1/2 HWH AB Zinc Red (Qty. 2) (234-5001-02) Item 7 >no wiring< use 190-5004-00; Item 7 >Wiring & Connector only< use 036-5517-10-92. Item 7 is required for use with the Bi-Directional Motor; For more details on Item 7, see Section 5, Chapter 1, Backbox Wiring, Page 97.			
8*	Diode Terminal Strip/Fuse Decals A-C	1	820-6221-92
Note: For Decal Descriptions & Locations, see Playfield Terminal Strips, Fuses & Misc. Wiring Descriptions & Locations, Section 5, Chapter 2, Playfield Wiring.			

Nr.	MISC. BRACKETS (BELOW)	QTY.	SPI PART Nr.
9	Bracket, Playfield Support Slide	2	535-6862-05
Item 9 is secured by: #10 X 1/2" HWH A (Zinc) (Qty. 2/per) (237-5817-00), #8-32 X 5/8" SHWH Swage (Zinc) Wax (Qty. 1/per) (237-5975-03) and #8-32 T-Nut (Qty. 1/per) (240-5101-00)			
10	Bracket, Edge Slide (Extended)	2	535-5988-01
Item 10 is secured by: #4 X 1/2" PFH (Zinc) (Qty. 5/per) (237-5840-00)			
11	Bracket, Pivot Pin Welded Assembly	2	500-5329-03
Item 11 is secured by: #8-32 X 5/8" SHWH Swage (Zinc) Wax (Qty. 2/per) (237-5975-03)			
12	Bracket, Back Panel Mounting	2	535-8964-00
Item 12 is secured by: #8 X 1/2" SHWH AB (Zinc) (Qty. 2/per) (234-5101-00)			
13	Tie Post (White Nylon)	8	545-5253-01
Item 13 is secured by: #8 X 5/8" SHWH AB Green (Qty. 1/per) (234-5102-04)			

Sec. .4: Parts Id. ...

## Take Note:

\* An asterisk ( \* ) indicates item(s) are not noted in the pictorials.

### Legend Note:

Items noted with a black square ■ are Miscellaneous Parts (Below).  
Items noted with a green square ■ are Misc. Brackets (Below).



# Playfield Top - Switches (Above)

Nr.	SWITCHES	QTY.	SPI PART Nr.
	Roll-Under Switch Gate	3	<b>Ind. Parts Only</b>
<b>A-#</b>	<i>Individual Parts Only</i> : Switch (180-5087-00), Sw. Gate Bracket (Qty. 1/per) (535-7756-01), Wire Form on Bracket (535-7755-01), Switch Body Protect Plate (Qty. 1/per) (535-6539-00), Diode 1N4004 (Qty. 1/per) (112-5003-00) and #2-56 X 1/2" Unslotted Serr. HWH #4 Head TR3 Black (Qty. 2/per) (237-5937-02)		
	Switch (for Playfield Wire Gates)	4	180-5087-00

Also see Section 4, Chapter 2, (Blue Pages): Left Ramp Assembly, Page 86, Right Plastic Ramp Assembly (Middle Lane), Page 89 and Left Orbit Flat Rail #1, Page 92.  
Switch Matrix Numbers 8, 10, 13 & 58.

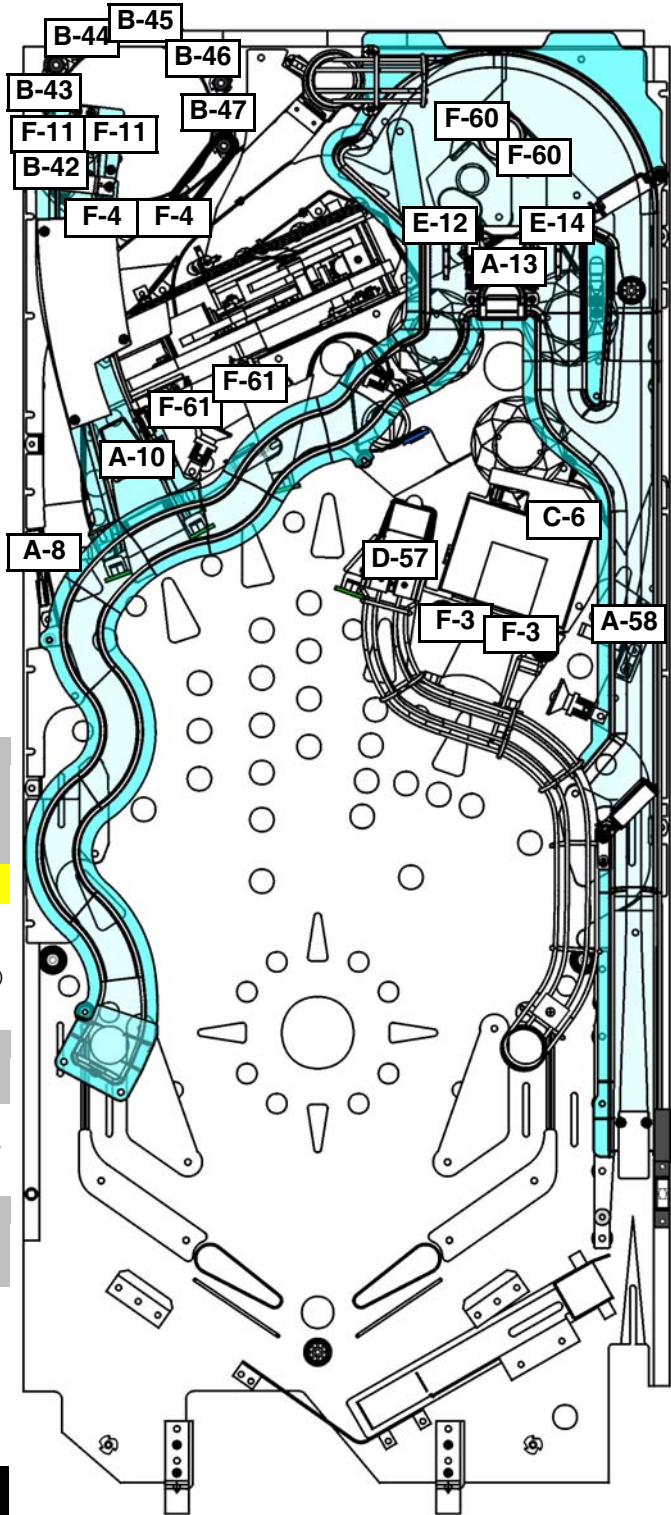
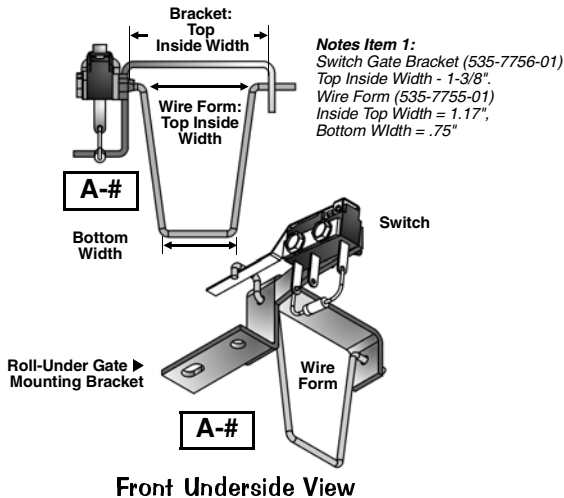

**B-#** Switch & Target Asm. 1" Sq. Lugs Rt. (Yellow) 6 515-7497-06-01  
**Assembly Parts Included** : Stack Sw. Radius End Lugs Right (180-5133-02), Square Target White (545-5470-08), Rivet 1/8"  $\phi$  X 3/16" (249-5001-00) and Washer 9/64" I.D. X 5/16" O.D. X .048" Thick (Zinc) (242-5017-00)  
Also see Section 4, Chapter 2, (Blue Pages): Spinning Disk Assembly (Targets), Page 84.  
Switch Matrix Numbers 42, 43, 44, 45, 46 & 47

**Note** : B Plastic Targets are riveted with : Rivet 1/8"  $\phi$  X 3/16" (Qty. 1/per) (249-5001-00) and Washer 9/64" I.D. X 5/16" O.D. X .048" Thick (Zinc) (Qty. 1/per) (242-5017-00)

**C-6** Switch (Roller Actuator, Lite-Force) 1 180-5119-02  
**Associated Parts Not Included** : Heat Shrink Tubing 1/8"  $\phi$  PUI-24 (Qty. 1" per) (605-5006-00) and Diode 1N4004 (Qty. 1/per) (112-5003-00)  
**Item C-6 is secured by** : #2-56 X 1/2" Unslotted HWH #4 Hex TR3 Blk (Qty. 2/per) (237-5937-02)  
Also see Section 4, Chapter 2, (Blue Pages): Flat Rail #14, Page 92.  
Switch Matrix Number 6

**D-57** Switch (Cherry #63) 1 180-5210-00  
Also see Section 4, Chapter 2, (Blue Pages): Reverse-O-Matic (Scoop) Assembly, Page 87.  
Switch Matrix Number 57

**E-#** Switch (Happ #95-1128-00) 2 180-5183-00  
Also see Section 4, Chapter 2, (Blue Pages): Right Plastic Ramp Asm. (Left & Right Lanes), Page 89.  
Switch Matrix Numbers 12 & 14

**F-#** Transceiver OPTO PCB Assembly 5/pair 500-6775-00  
Also see Section 4, Chapter 2, (Blue Pages): Treasure Chest Enter, Page 77, Spinning Disk Cover, Page 85, Left Plastic Ramp Asm., Page 86 and Flat Rails #5, #7 & #9, Page 93.  
Switch Matrix Numbers 3, 4, 11, 60 & 61 **Switch Note**: Pairs required per switch.

### example:

"A-#" means, it is Item Number A-# in the Part Table. The "-#" indicates more than 1 switch is present. So it is replaced with the Switch's "Switch Matrix Number" (e.g. A-8, Item A Switch and one of the Switches referenced is from Switch Matrix Number 8).

If only 1 switch type for the item exists, the Switch Number will be listed with the Item Number (e.g. C-6, Item C Switch and the Switch Matrix Number is 6).

Sec. 4: Parts Id. ...

# Playfield Bottom - Switches (Below)

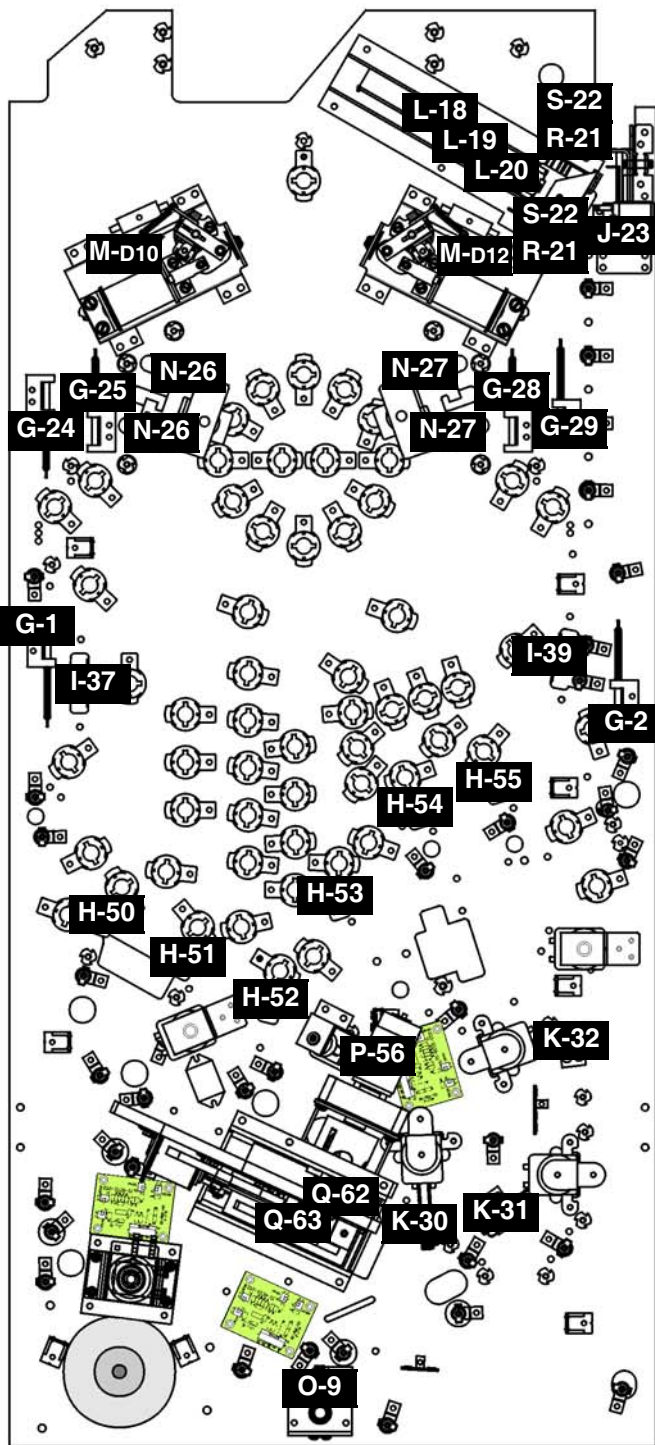

Nr.	SWITCHES	QTY.	SPI PART Nr.
<b>G-#</b>	Sw., Roll-Over Lite Force ( <i>Right Mount Style</i> )	6	500-6227-04
Bracket secured to Playfield by: #6 X 1/2" SHWH AB (Zinc) (Qty. 2/per) (234-5001-02)			
Switch Matrix Numbers 1, 2, 24, 25, 28 & 29			
<b>H-#</b>	Switch & Target Riv. Asm. 1/2" (Green) Anti-Loft	6	515-7581-04
<b>Assembly Parts Included</b> : Stack Sw. (180-5208-00) and 1/2" Target Green (545-5145-06)			
<b>Not Included, order separately</b> : Switch Mounting Bracket (535-6896-00), Switch Back Plate (535-9823-01), Foam (Thicker) Pad (626-5069-00) and #6-32 X 3/4" HWH Swage (Zinc) (Qty. 2) (237-5976-05)			
Switch Matrix Numbers 50, 51, 52, 53, 54 & 55			
<b>i-#</b>	Switch & Target Riveted Asm. 1-1/2" (Yellow)	2	515-6027-06
<b>Asm. Parts Included</b> : Stack Switch (180-5183-00) and 1-1/2" Target Yellow (545-5145-06)			
<b>Not Included, order separately</b> : Switch Mounting Bracket (535-6896-00), Switch Back Plate (535-6452-00), Foam Pad (626-5029-00) and #6-32 X 3/4" HWH Swage (Zinc) (Qty. 2) (237-5976-05)			
Switch Matrix Numbers 37 & 39			
<b>Note</b> : H-i Plastic Targets are rivted with : Rivet 1/8" ø X 3/16" (Qty. 1/per) (249-5001-00) and Washer 9/64" I.D. X 5/16" O.D. X .048" Thick (Zinc) (Qty. 1/per) (242-5017-00)			
H & i Brackets secured to P/F by: #8 X 1/2" SHWH AB (Zinc) (Qty. 2/per) (234-5101-00)			
<b>J-23</b>	Switch ( <i>for Shooter Lane</i> )	1	180-5157-00
<b>Associated Part Not Included</b> : Switch Mounting Bracket (535-6173-00)			
Bracket secured to Playfield by: #6 X 1/2" SHWH AB (Zinc) (Qty. 2) (234-5001-02)			
Also see Section 4, Chapter 2, ( <a href="#">Blue Pages</a> ): Shooter Lane Switch Assembly, Page 66.			
<b>K-#</b>	Switch Asm., Stack (Blade) ( <i>for Pops</i> )	3	515-6459-09
<b>Assembly Parts Included</b> : Switch (180-5015-04), Sw. Mounting Bracket (535-7342-00), Spoon Actuator (545-5610-02), Switch Body Protect Plate (535-7344-00), Diode 1N4004 (Qty. 1/per) (112-5003-00) and #6-32 X 3/4" HWH Zc (Qty. 2/per) (237-5976-05)			
Bracket secured to Playfield by: #8 X 1/2" SHWH AB (Z) (Qty. 2) (234-5101-00)			
Also see Section 4, Chapter 2, ( <a href="#">Blue Pages</a> ): Bumper Switch Individual Parts ..., Page 71.			
Switch Matrix Numbers 30, 31 & 32			
<b>L-#</b>	Switch ( <i>Roller Actuator, Lite-Force</i> )	3	180-5119-02
<b>Associated Parts Not Included</b> : Heat Shrink Tubing 1/8" ø PUI-24 (Qty. 1" per) (605-5006-00) and Diode 1N4004 (Qty. 1/per) (112-5003-00)			
Item L-# is secured by: #2-56 X 1/2" Unslt HWH #4 Hex TR3 Blk (Qty. 2/per) (237-5937-02)			
Also see Section 4, Chapter 2, ( <a href="#">Blue Pages</a> ): 4-Ball Trough Assembly, Page 67.			
Switch Matrix Numbers 18, 19 & 20			
<b>M-#</b>	Switch (End-of-Stroke), Stack (Blade)	2	180-5149-00
Item M-# is secured by: #6-32 X 5/8" HWH Sw (Sr) Zc (Qty. 2/per) (237-5976-04)			
Also see Section 4, Chapter 2, ( <a href="#">Blue Pages</a> ): ... Flipper Assemblies, Pages 68-69.			
Dedicated Switch Numbers D10 & D12			
<b>N-#</b>	Switch, Stack (Blade)	4	180-5054-00
<b>Associated Parts Not Included</b> : Switch Body Protect Plate (Qty. 1/per) (535-5045-00) and Diode 1N4004 (Qty. 1 for every 2 connected together) (112-5003-00)			
Item N-# is secured by: #6-32 X 5/8" HWH Swage (Ser.) Zinc (Qty. 2/per) (237-5976-04)			
Also see Section 4, Chapter 2, ( <a href="#">Blue Pages</a> ): Slingshot Assemblies, Page 70.			
Switch Matrix Numbers 26 & 27 (Dual Switches = Slingshots)			
<b>O-9</b>	Switch ( <i>Sim. Roller Actuator</i> ) VUKs	1	180-5209-00
Also see Section 4, Chapter 2, ( <a href="#">Blue Pages</a> ): Vertical Up-Kicker Assembly, Page 72.			
<b>P-56</b>	Switch (used in conjunction with 30° Ejects)	1	180-5186-01
Also see Section 4, Chapter 2, ( <a href="#">Blue Pages</a> ): Used in conj. with 30° Eject Asm., Page 75.			
<b>Q-#</b>	Switch	2	180-5189-00
Also see Section 4, Chapter 2, ( <a href="#">Blue Pages</a> ): Pirate Ship Assembly, Page 81.			
Switch Matrix Numbers 62 & 63			
<b>R-21</b>	Dual OPTO TRANS PC Board Asm.	1	515-0173-00
<b>Assembly Parts Included</b> : Dual OPTO Trans. PCB (Qty. 1) (520-5173-00), OPTO PCB Tube Spacer (Brass) (Qty. 3) (530-5308-02) and Rubber Grommet (Qty. 3) (545-5518-00)			
<b>S-22</b>	Dual OPTO REC PCB Assembly	1	515-0174-00
<b>Assembly Parts Included</b> : Dual OPTO Rec. PCB (Qty. 1) (520-5174-00), OPTO PCB Tube Spacer (Brass) (Qty. 3) (530-5308-02) and Rubber Grommet (Qty. 3) (545-5518-00)			
Items R-#-S-# are secured by: #6-32 X 5/8" HWH Sw. (Ser.) Zc. (Qty. 3/per) (237-5976-04)			
Switch Matrix Numbers 21 & 22 <b>Switch Note</b> : Both R & S PCBs required per switch.			

Sec. 4: Parts Id. ...

**example:**

"G-#" means, it is Item Number A-# in the Part Table. The "-#" indicates more than 1 switch is present. So it is replaced with the Switch's "Switch Matrix Number" (e.g. G-1, Item G Switch and one of the Switches referenced is from Switch Matrix Number 1).

If only 1 switch type for the item exists, the Switch Number will be listed with the Item Number (e.g. J-23, Item J Switch and the Switch Matrix Number is 23).



# Playfield Top - Flat Rails , Wood Rails , Ball Guides & Wire Forms

VUK Tube, see Item 12, Pages 88-89.

Nr.	FLAT RAILS	QTY.	SPI PART Nr.
FR0	Flat Rail #0	1	535-9802-00
Item FR0 is secured by: <span style="background-color: red; font-size: 0.8em;">❖</span> (Qty. 2) and <span style="background-color: red; font-size: 0.8em;">◆</span> (Qty. 2)			
FR1	Flat Rail #1 (Left Orbit)	1	515-7620-01
Item FR1 is secured by: <span style="background-color: red; font-size: 0.8em;">■</span> (Qty. 1/ab) and <span style="font-size: 0.8em;">⌘</span> (Qty. 1)			
FR2	Flat Rail #2	1	535-9802-02
Item FR2 is secured by: <span style="background-color: red; font-size: 0.8em;">■</span> (Qty. 2), <span style="background-color: red; font-size: 0.8em;">◆</span> (Qty. 1) and <span style="background-color: red; font-size: 0.8em;">❖</span> (Qty. 1)			
FR3	Flat Rail #3	1	535-9802-03
Item FR3 is secured by: <span style="background-color: red; font-size: 0.8em;">■</span> (Qty. 1), <span style="background-color: red; font-size: 0.8em;">❖</span> (Qty. 1), <span style="background-color: red; font-size: 0.8em;">◆</span> (Qty. 1) and <span style="border: 1px solid black; display: inline-block; width: 5px; height: 5px;"></span> (Qty. 1)			
FR4	Flat Rail #4	1	535-9802-04
Item FR4 is secured by: <span style="background-color: red; font-size: 0.8em;">■</span> (Qty. 2)			
FR5	Flat Rail #5 (under ship left side)	1	535-9802-05
Item FR5 is secured by: <span style="background-color: red; font-size: 0.8em;">❖</span> (Qty. 2) and <span style="background-color: red; font-size: 0.8em;">◆</span> (Qty. 2); (REF. ONLY 511-5019-05)			
FR6	Flat Rail #6	1	535-9802-06
Item FR6 is secured by: <span style="background-color: red; font-size: 0.8em;">❖</span> (Qty. 3) and <span style="background-color: red; font-size: 0.8em;">◆</span> (Qty. 3)			
FR7	Flat Rail #7 (under ship right side)	1	535-9802-07
Item FR7 is secured by: <span style="background-color: red; font-size: 0.8em;">❖</span> (Qty. 2) and <span style="background-color: red; font-size: 0.8em;">◆</span> (Qty. 2); (REF. ONLY 511-5019-07)			
FR8	Flat Rail #8	1	535-9802-08
Item FR8 is secured by: <span style="background-color: red; font-size: 0.8em;">■</span> (Qty. 4), <span style="background-color: red; font-size: 0.8em;">❖</span> (Qty. 1), <span style="background-color: red; font-size: 0.8em;">◆</span> (Qty. 1) and <span style="font-size: 0.8em;">⌘</span> (Qty. 2)			
FR9	Flat Rail #9	1	535-9802-09
Item FR9 is secured by: <span style="background-color: red; font-size: 0.8em;">■</span> (Qty. 1/per); (REF. ONLY 511-5019-09)			
FR10	Flat Rail #10	1	535-9802-10
Item FR10 is secured by: <span style="background-color: red; font-size: 0.8em;">■</span> (Qty. 2)			
FR11	Flat Rail #11	1	535-9802-
Item FR11 is secured by: <span style="background-color: red; font-size: 0.8em;">❖</span> (Qty. 2) and <span style="background-color: red; font-size: 0.8em;">◆</span> (Qty. 2)			
FR12	Flat Rail #12 (by Bumper Eject Hole)	1	535-9802-12
Item FR12 is secured by: <span style="background-color: red; font-size: 0.8em;">❖</span> (Qty. 1) and <span style="background-color: red; font-size: 0.8em;">◆</span> (Qty. 1); (REF. ONLY 511-5019-12)			
<b>Attached to Item FR12 is:</b> Bumper Bracket (535-9648-00) and Rubber Bumper <span style="color: blue;">Blue</span> (626-5067-00) and is secured by: #4-40 X 1/4" PFH MS Black (Qty. 2) (237-5983-02)			
FR13	Flat Rail #13 & Gate Riveted Asm.	1	510-5020-13
Item FR13 is secured by: <span style="background-color: red; font-size: 0.8em;">■</span> (Qty. 1), <span style="background-color: red; font-size: 0.8em;">❖</span> (Qty. 1) and <span style="background-color: red; font-size: 0.8em;">◆</span> (Qty. 1)			
FR14	Flat Rail #14	1	535-9802-14
Item FR14 is secured by: <span style="background-color: red; font-size: 0.8em;">❖</span> (Qty. 4) and <span style="background-color: red; font-size: 0.8em;">◆</span> (Qty. 4); (REF. ONLY 511-5019-14)			
FR15	Flat Rail #15	1	535-9802-15
Item FR15 is secured by: <span style="background-color: red; font-size: 0.8em;">■</span> (Qty. 1) and <span style="border: 1px solid black; display: inline-block; width: 5px; height: 5px;"></span> (Qty. 1)			
FR16	Flat Rail #16 (use -22)	1	535-9802-22
Item FR16 is secured by: <span style="background-color: red; font-size: 0.8em;">■</span> (Qty. 2)			
FR17	Flat Rail (Bottom Arch Drain)	1	535-8393-00
Item FR17 is secured by: <span style="background-color: red; font-size: 0.8em;">■</span> (Qty. 4)			
FR18	Flat Rail Cover (Shooter Lane, GI)	1	535-9839-00
Item FR18 is secured by: #6-32 X 1-1/2" PPH MS (Zinc) (Qty. 5) (237-5510-00) into #6-32 T-Nut (Qty. 5) (240-5002-00) and 5/8" X 3/8" Plastic Spacer (Qty. 5) (254-5000-14)			
<b>Note:</b> For a 3D view of Items <b>FR1, FR5, FR7, FR9, FR12, FR13 &amp; FR14</b> , see Section 4, Chapter 2, Drawings for Major Assemblies & Ramps (Blue Pages), Pages 92-93.			

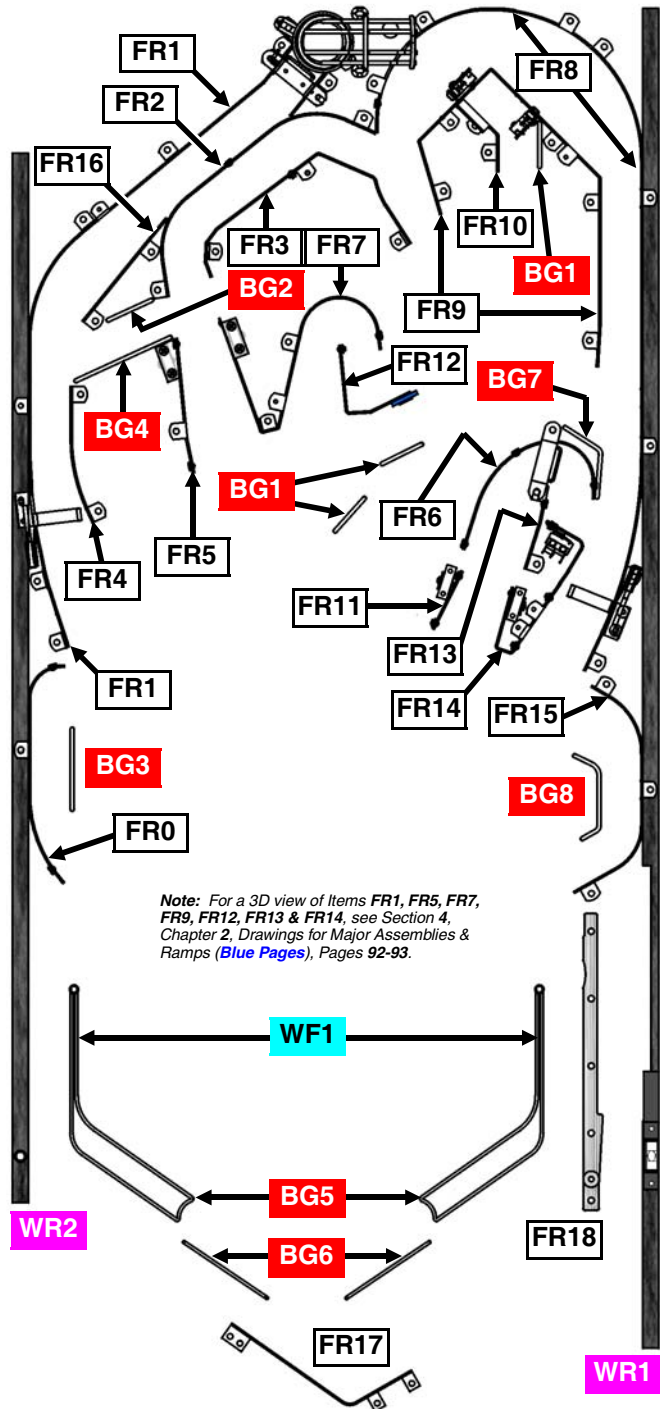

Sec. 4: Parts Id. ...

Nr.	WOOD RAILS	QTY.	SPI PART Nr.
WR1	Wood Rail, 42.00" X 1.13" (7" Notch)	1	525-5661-00
WR2	Wood Rail, 32.88" X 1.13" (1.25" Notch)	1	525-5661-01
Items WR1-WR2 are secured by: #6 X 1-1/4" PFH A (Zinc) (WR1 Qty. 6 // WR2 Qty. 5) (237-5804-00)			

Nr.	BALL GUIDES	QTY.	SPI PART Nr.
BG1	Ball Guide, 1.375" X .12" ø	3	535-5356-23
BG2	Ball Guide, 1.5" X .12" ø	1	535-5356-20
BG3	Ball Guide, 2.5" X .12" ø	1	535-5356-09
BG4	Ball Guide, 3.25" X .12" ø	1	535-5356-08
BG5	Ball Guide, Plastic (Long, Clear)	2	550-5037-01
Item BG5 is secured by: #6-32 X 2" PPH MS (Zinc) (Qty. 4/per) (237-5513-00) and #6-32 T-Nut (Qty. 4/per) (240-5002-00)			
BG6	Ball Guide (Snubber), 3.125"	2	535-5373-01
BG7	Ball Guide, .12" ø (single-bend)	1	535-9945-00
<b>Location Note:</b> Item <b>BG7</b> is located behind the Treasure Chest Assembly, under plastic.			
BG8	Ball Guide, .12" ø (double-bend)	1	535-5642-00
<b>Location Note:</b> Item <b>BG8</b> is located behind the Right Yellow Rectangle Target, under plastic.			

Nr.	WIRE FORMS	QTY.	SPI PART Nr.
WF1	Wire Form (on Item BG5 Ball Guide)	1/per	535-5642-00
For Wire Forms on Roll-Under Switch Gates or 1-Way Gates, see Previous Page 50 or Section 4, Chapter 2, Drawings for Major Assemblies & Ramps (Blue Pages), Pages 86-93.			

**Take Note:**

**Legend Note:**  
 Items noted with a white square  are Flat Rails.  
 Items noted with a magenta square  are Wood Rails.  
 Items noted with a red square  are Ball Guides (Snubber Wires)  
 Items noted with a cyan square  are Wire Forms.

- #8 X 1/2" SHWH AB (Zinc) (234-5101-00)
- ❖ #8-32 Nylon Stop Nut (240-5102-00)
- ◆ #8 Washer (242-5005-00)
- ☒ #6-32 X 7/8" Fin Shank Screw (237-5921-04)
- ⌘ #6-32 X 1/2" PTH A (Zinc) (237-5809-00) into Wood Rail.



# Playfield Top - Plastics (Screened & Clear) Kit, Decals\* & Mylar\* Kits ‡

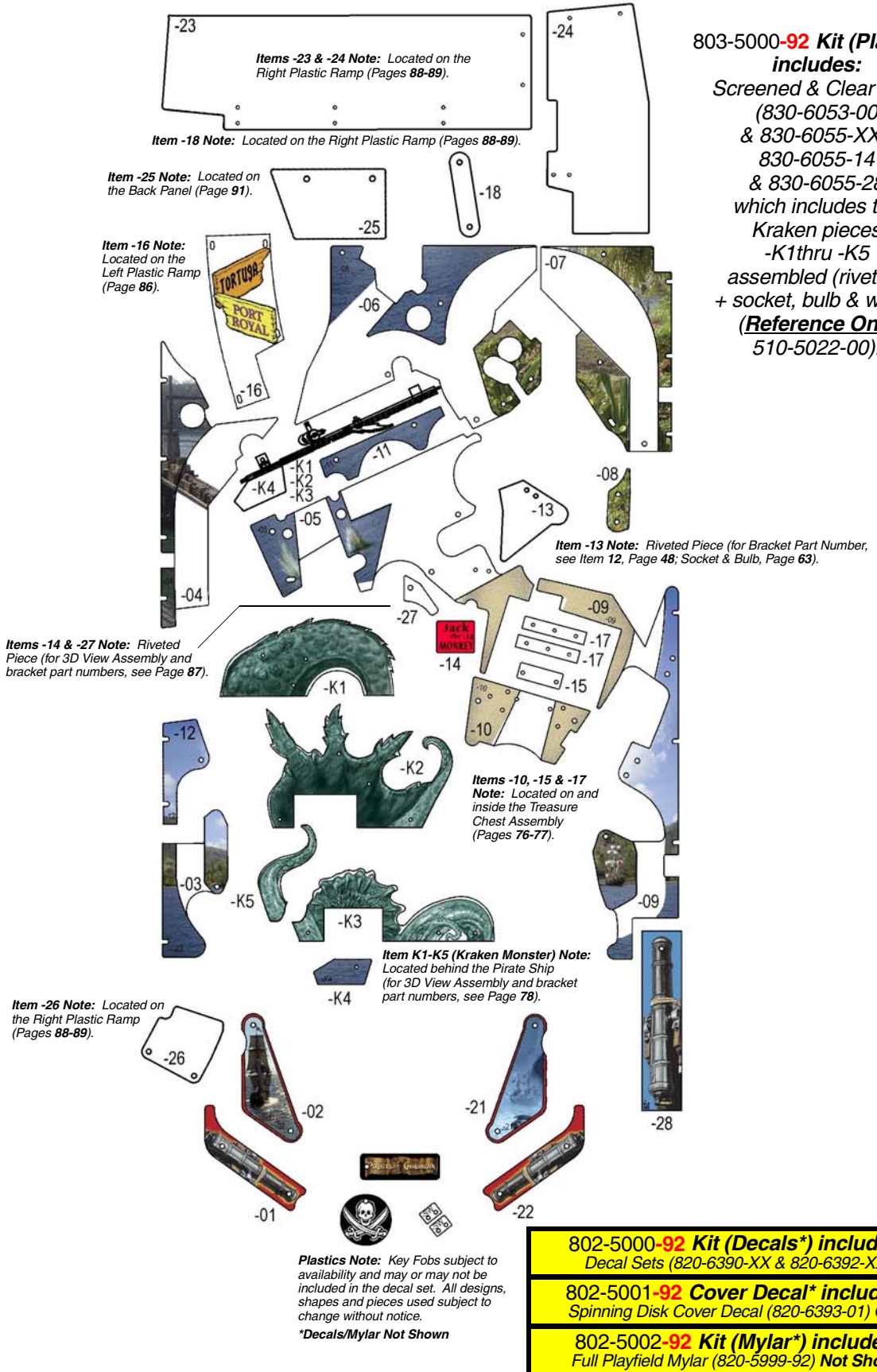

803-5000-92 Kit (Plastics) includes:  
 Screened & Clear Sets  
 (830-6053-00 & 830-6055-XX)  
 830-6055-14 & 830-6055-28  
 which includes the Kraken pieces  
 -K1 thru -K5 assembled (riveted)  
 + socket, bulb & wiring  
 (Reference Only 510-5022-00).

Sec. .4: Parts Id. ...

‡ **Attention:** No individual Plastic or Decal can be ordered separately, unless noted otherwise.  
 Plastics & Decals are subject to change without notice during and / or after production. Shapes and / or Screening may change.  
 Pieces can be added or subtracted. Service Bulletin(s) will announce any critical changes, if warranted.



# Playfield Top & Bottom - Metal Posts & Fin Shank Screws (Actual Size) †

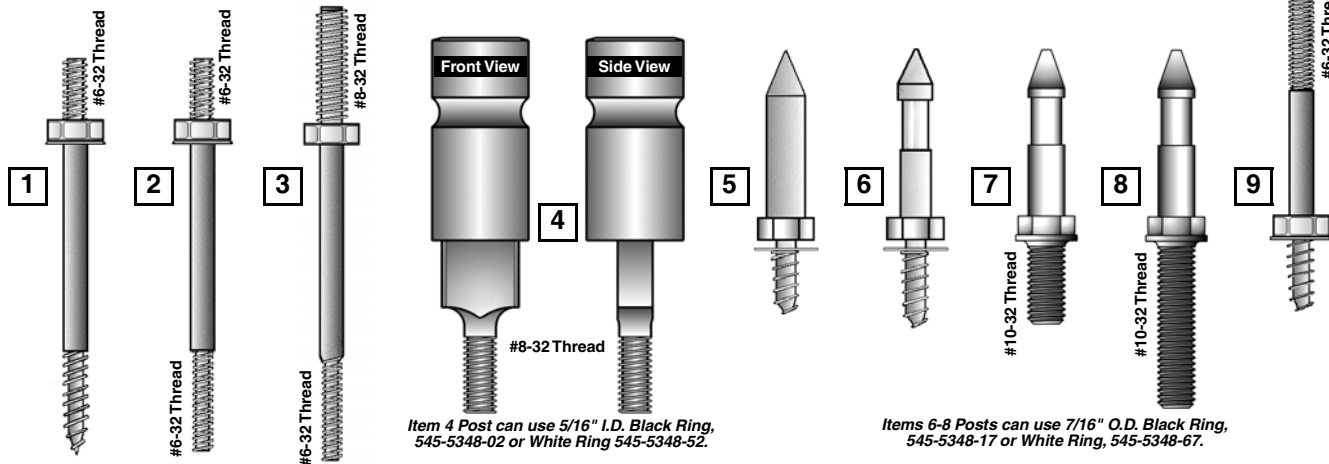

Item 4 Post can use 5/16" I.D. Black Ring, 545-5348-02 or White Ring 545-5348-52.

Items 6-8 Posts can use 7/16" O.D. Black Ring, 545-5348-17 or White Ring, 545-5348-67.

## Take Note:

**Legend Note:**  
Items noted with a white square  are Metal Posts. Items noted with a black square  are Fin Shank Screws.

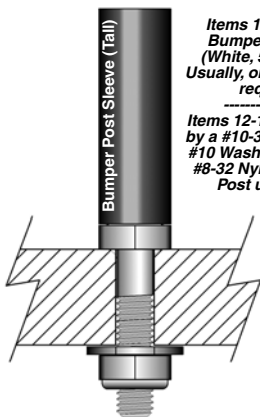

Items 11-16 & 18 Posts can use a Black Bumper Post Sleeve (Tall), 545-5308-00 (White, 545-5308-08 or Red, 545-5308-22) Usually, only Posts which are in the ball path require a Bumper Post Sleeve.

Items 12-15 & 18 Posts are typically secured by a #10-32 Nylon Stop Nut, 240-5203-00 and #10 Washer, 242-5003-00 (Item 11 Post use a #8-32 Nylon Stop Nut, 240-5102-00; Item 16 Post use a #8-32 T-Nut, 240-5101-00).

**A & B**

**C**

**D**

**A - D**

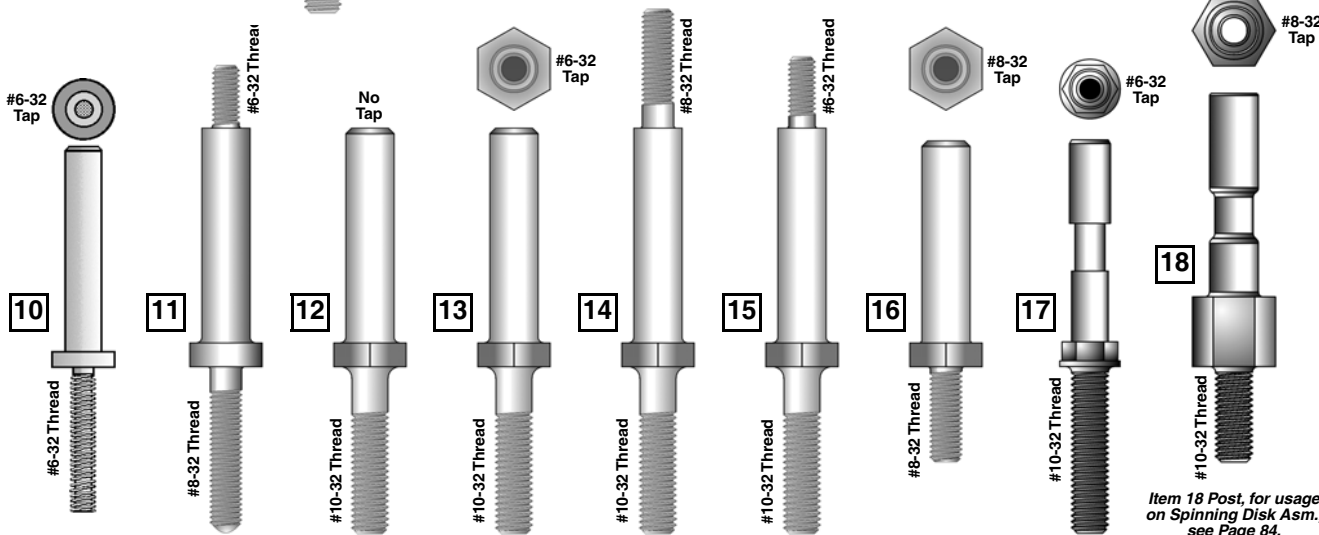
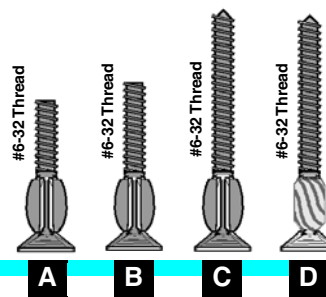

Item 18 Post, for usage on Spinning Disk Asm., see Page 84.

Sec. 4: Parts Id. ...

Nr.	METAL POSTS	QTY.	SPI PART Nr.	Nr.	METAL POSTS	QTY.	SPI PART Nr.
1	Post [Fasten] #6-32 Thread // Wood Scr.	3	530-5010-02	13	Post [Hex Bs.] #6-32 TAP // #10-32 Thread		530-5332-01
2	Post [Fasten] #6-32 Thread // #6-32 Thread	4	530-5012-02	14	Post [Hex Bs.] #8-32 Thread // #10-32 Thread		530-5332-02
3	Post [Fasten] #8-32 Thread // #6-32 Thread		530-5008-00	15	Post [Hex Bs.] #6-32 Thread // #10-32 Thread	1	530-5332-03
4	Post Brass [Adjustable, Sliding] #8-32 Thread		530-5621-00	16	Post [Hex Bs.] #8-32 TAP // #8-32 Thread	1	530-5332-04
5	Mini-Post Wood Screw (no cut-away)	4	530-5004-01	17	Post [Hex Bs.+Groove] #6-32 TAP // #10-32 Thr.	17	530-5679-00
6	Mini-Post Wood Screw		530-5004-00	18	Post [Hex Bs.+Groove] #8-32 TAP // #10-32 Thr.	9	530-5753-00
7	Mini-Post MS // #10-32 .4" Thread		530-5005-01				
8	Mini-Post MS // #10-32 .875" Thread	1	530-5005-00	<b>Nr.</b>	<b>FIN SHANK SCREWS</b>	<b>QTY.</b>	<b>SPI PART Nr.</b>
9	Post [Fasten] #6-32 Thread // Wood Screw		530-5263-01	A	#6-32 X 3/4" Fin Shank Screw		237-5921-02
10	Post #6-32 Tap // #6-32 Thread		530-5127-00	B	#6-32 X 7/8" Fin Shank Screw	1	237-5921-04
11	Post [Fasten] #6-32 Thread // #8-32 Thread		530-5007-00	C	#6-32 X 1 1/4" Fin Shank Screw	(4)	237-5883-00
12	Post [Hex Base] NO TAP // #10-32 Thread		530-5332-00	D	#6-32 X 1 3/16" Spiral Fin Shank Screw	9	237-5957-00

† The item type (size / description), the quantity and/or location used, are subject to change without notice. Service Bulletins will announce any changes, if warranted.



# Playfield Top & Bottom - Metal Posts & Fin Shank Screws Continued

† The item type (size / description), the quantity and/or location used, are subject to change without notice. Service Bulletins will announce any changes, if warranted.

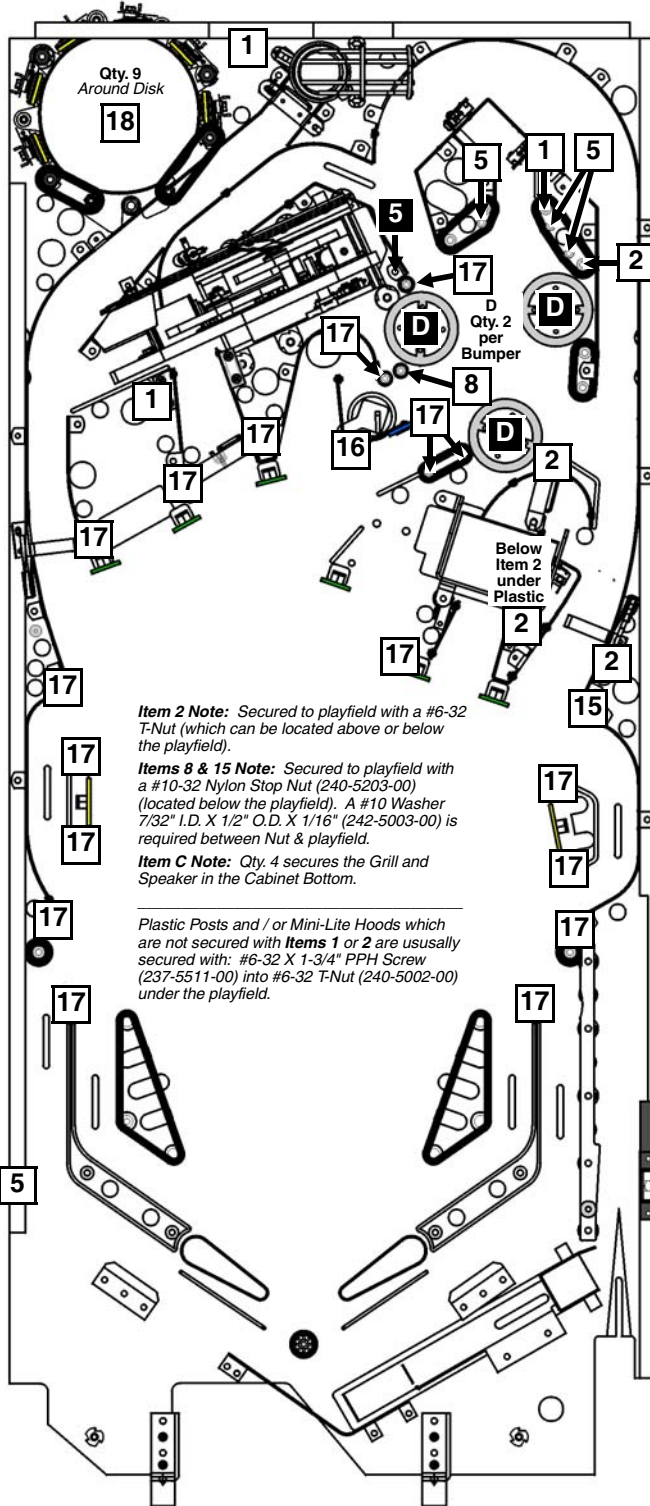

**Item 2 Note:** Secured to playfield with a #6-32 T-Nut (which can be located above or below the playfield).

**Items 8 & 15 Note:** Secured to playfield with a #10-32 Nylon Stop Nut (240-5203-00) (located below the playfield). A #10 Washer 7/32" I.D. X 1/2" O.D. X 1/16" (242-5003-00) is required between Nut & playfield.

**Item C Note:** Qty. 4 secures the Grill and Speaker in the Cabinet Bottom.

Plastic Posts and / or Mini-Lite Hoods which are not secured with **Items 1** or **2** are usually secured with: #6-32 X 1-3/4" PPH Screw (237-5511-00) into #6-32 T-Nut (240-5002-00) under the playfield.

## Take Note:

**Legend Note:**  
Items noted with a white square  are Metal Posts.  
Items noted with a black square  are Fin Shank Screws.

# Playfield Top & Bottom - Nylon Stop, KEPS, Hex, T-, Flange, Pal & Wing Nuts\* (Actual Size) †

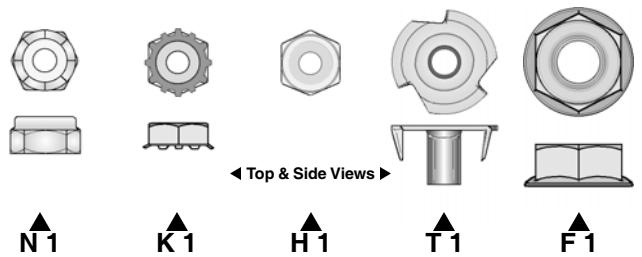

Nr.	NYLON STOP NUTS*	QTY.	SPI PART Nr.
N1	#6-32 Nylon Stop Nut	68	240-5005-00
N2	#6-32 N.S. Nut (with 1/4" Hex Body)		240-5010-00
N3	#8-32 Nylon Stop Nut	29	240-5102-00
N4	#10-32 Nylon Stop Nut	23	240-5203-00
N5	#10-24 Nylon Stop Nut	2	240-5206-00
<i>Item N5 used with #10-24 X 1-3/4" Carriage Bolt Square Neck Black (231-5022-00) located in the Cabinet for the Roto Lock (Male) (355-5006-01).</i>			
N6	#4-40 Nylon Stop Nut		240-5303-00
N7	#4-40 (18/8 Stainless) Nylon Stop Nut		240-5303-01
N8	5/16"-18 Nylon Stop Nut		240-5316-00
Nr.	KEPS NUTS*	QTY.	SPI PART Nr.
K1	#6-32 Keps Nut (with Star Washer)	6	240-5008-00
K2	#6-32 Keps Nut (with 1/4" Hex Body)		240-5011-00
K3	#8-32 Keps Nut		240-5104-00
K4	#10-32 Keps Nut	1	240-5208-00
K5	#10-24 Keps Nut	14	240-5207-00
K6	#4-40 Keps Nut		240-5318-00
Nr.	HEX NUTS*	QTY.	SPI PART Nr.
H1	#6-32 Hex Nut (No Star Washer)	4	240-5004-00
H2	#8-32 Hex Nut		240-5103-00
H3	#10-32 Hex Nut		240-5201-00
H4	#10-24 Hex Nut	2	240-5202-00
<i>Item H4 used with #10-24 X 1" Carriage Bolt Square Neck Black (231-5021-00) located in the Cabinet for the Side Armor Rear (towards Backbox).</i>			
H5	#10-32 X 3/8" Hex Nut		240-5209-00
H6	3/4"-16 Hex Nut		240-5315-00
H7	#2-56 Hex Nut	12	240-5301-00
H8	7/8"-14 Hex Nut		240-5317-00
Nr.	T-NUTS*	QTY.	SPI PART Nr.
T1	#6-32 T-Nut	26	240-5002-00
T2	#6-32 T-Nut (with Side Cut Off)		240-5002-01
T3	#8-32 T-Nut	10	240-5101-00
T4	#10-32 (Black Oxide) T-Nut	10	240-5007-00
T5	#10-32 T-Nut (with Side Cut Off)		240-5205-00
T6	#10-32 X 5/16" T-Nut		240-5204-00
T7	#10-24 T-Nut		240-5200-00
Nr.	FLANGE NUT*	QTY.	SPI PART Nr.
F1	1/4" X 20 Flange Nut	10	240-5300-00
<i>Item F1 used with 1/4-20 X 1-1/4 Sq. Neck Carriage Bolt Black (231-5003-00) located in the Cabinet for the Slide Armor (Front) and Pivot Hinges.</i>			
Nr.	PAL NUTS*	QTY.	SPI PART Nr.
P1	Plastic Pal Nut (on Flipper Buttons)		240-5003-00
P2	Metal Pal Nut (on Flipper Buttons)	2	240-5003-01
Nr.	WING NUTS*	QTY.	SPI PART Nr.
W1	#6-32 Wing Nut		240-5001-00
W2	#8-32 Wing Nut		240-5100-00
W3	#10-24 Wing Nut		240-5211-00
W4	1/4"-20 Wing Nut		240-5302-00
W5	1/4"-20 Toggle Wing		240-5324-00
<b>* Not Shown:</b> Items N2-N8, K2-K6, H2-H8, T2-T7, P1-P2 & W1-W5			

Sec. 4: Parts Id. ...



# Playfield Top - Hex Spacers   (Actual Size) †

Hex Spacers:  
#6-32  
Tap

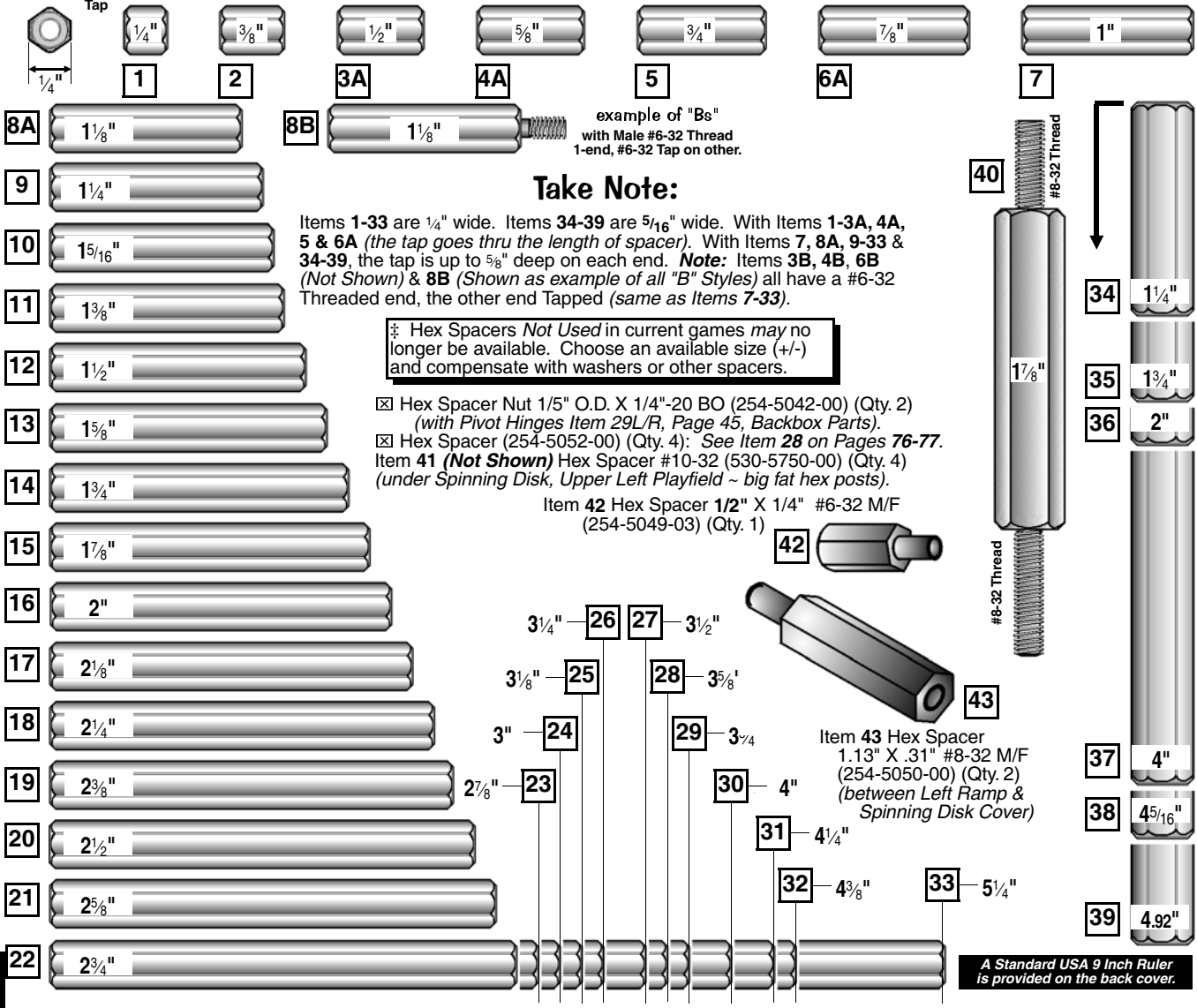

## Take Note:

Items 1-33 are 1/4" wide. Items 34-39 are 5/16" wide. With Items 1-3A, 4A, 5 & 6A (the tap goes thru the length of spacer). With Items 7, 8A, 9-33 & 34-39, the tap is up to 5/8" deep on each end. **Note:** Items 3B, 4B, 6B (Not Shown) & 8B (Shown as example of all "B" Styles) all have a #6-32 Threaded end, the other end Tapped (same as Items 7-33).

‡ Hex Spacers Not Used in current games may no longer be available. Choose an available size (+/-) and compensate with washers or other spacers.

- ☒ Hex Spacer Nut 1/5" O.D. X 1/4"-20 BO (254-5042-00) (Qty. 2) (with Pivot Hinges Item 29L/R, Page 45, Backbox Parts).
- ☒ Hex Spacer (254-5052-00) (Qty. 4): See Item 28 on Pages 76-77.
- Item 41 (Not Shown) Hex Spacer #10-32 (530-5750-00) (Qty. 4) (under Spinning Disk, Upper Left Playfield ~ big fat hex posts).
- Item 42 Hex Spacer 1/2" X 1/4" #6-32 M/F (254-5049-03) (Qty. 1)

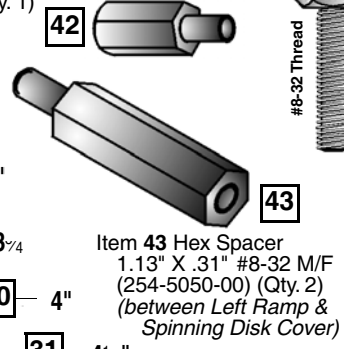

Item 43 Hex Spacer  
1.13" X .31" #8-32 M/F  
(254-5050-00) (Qty. 2)  
(between Left Ramp & Spinning Disk Cover)

Sec. 4: Parts Id. ...

Nr.	HEX SPACERS	QTY.	SPI PART Nr.	Nr.	HEX SPACERS	QTY.	SPI PART Nr.
1	1/4" X 1/4" : #6-32 Tap (both ends)		254-5008-00	19	2 3/8" X 1/4" : #6-32 Tap (both ends)		254-5008-28
2	3/8" X 1/4" : #6-32 Tap (both ends)		254-5008-12	20	2 1/2" X 1/4" : #6-32 Tap (both ends)	1	254-5008-16
3A	1/2" X 1/4" : #6-32 Tap (both ends)	1	254-5008-03	21	2 5/8" X 1/4" : #6-32 Tap (both ends)		254-5008-08
3B*	Identical to 3A with #6-32 Thread end		254-5024-03	22	2 3/4" X 1/4" : #6-32 Tap (both ends)		254-5008-15
4A	5/8" X 1/4" : #6-32 Tap (both ends)	2	254-5008-02	23	2 7/8" X 1/4" : #6-32 Tap (both ends)		254-5008-31
4B*	Identical to 4A with #6-32 Thread end		254-5024-02	24	3" X 1/4" : #6-32 Tap (both ends)		254-5008-14
5	3/4" X 1/4" : #6-32 Tap (both ends)		254-5008-04	25	3 1/8" X 1/4" : #6-32 Tap (both ends)		254-5008-19
6A	7/8" X 1/4" : #6-32 Tap (both ends)		254-5008-05	26	3 1/4" X 1/4" : #6-32 Tap (both ends)		254-5008-26
6B*	Identical to 6A with #6-32 Thread end		254-5024-05	27	3 1/2" X 1/4" : #6-32 Tap (both ends)		254-5008-27
7	1" X 1/4" : #6-32 Tap (both ends)		254-5008-06	28	3 5/8" X 1/4" : #6-32 Tap (both ends)	1	254-5008-25
8A	1 1/8" X 1/4" : #6-32 Tap (both ends)		254-5008-17	29	3 3/4" X 1/4" : #6-32 Tap (both ends)		254-5008-36
8B	Identical to 8A with #6-32 Thread end		254-5024-17	30	4" X 1/4" : #6-32 Tap (both ends)		254-5008-21
9	1 1/4" X 1/4" : #6-32 Tap (both ends)		254-5008-11	31	4 1/4" X 1/4" : #6-32 Tap (both ends)		254-5008-30
10	1 5/16" X 1/4" : #6-32 Tap (both ends)		254-5008-34	32	4 3/8" X 1/4" : #6-32 Tap (both ends)		254-5008-29
11 ‡	1 3/8" X 1/4" : #6-32 Tap (both ends)		254-5008-33	33	5 1/4" X 1/4" : #6-32 Tap (both ends)		254-5008-35
12 ‡	1 1/2" X 1/4" : #6-32 Tap (both ends)		254-5008-09	34	1 1/4" X 5/16" : #6-32 Tap (both ends)		254-5018-09
13 ‡	1 5/8" X 1/4" : #6-32 Tap (both ends)		254-5008-13	35	1 3/4" X 5/16" : #6-32 Tap (both ends)		254-5018-06
14 ‡	1 3/4" X 1/4" : #6-32 Tap (both ends)		254-5008-10	36	2" X 5/16" : #6-32 Tap (both ends)		254-5018-07
15 ‡	1 7/8" X 1/4" : #6-32 Tap (both ends)		254-5008-20	37	4" X 5/16" : #6-32 Tap (both ends)		254-5018-03
16	2" X 1/4" : #6-32 Tap (both ends)	1	254-5008-07	38	4 5/16" X 5/16" : #6-32 Tap (both ends)		254-5018-00
17	2 1/8" X 1/4" : #6-32 Tap (both ends)		254-5008-32	39	4.92" X 5/16" : #6-32 Tap (both ends)		254-5018-04
18	2 1/4" X 1/4" : #6-32 Tap (both ends)		254-5008-18	40	1 7/8" X 3/8" : #8-32 Thread (both ends)		530-5285-00

† The item type (size / description), the quantity and/or location used, are subject to change without notice. Service Bulletins will announce any changes, if warranted.





† The item type (size / description), the quantity and/or location used, are subject to change without notice. Service Bulletins will announce any changes, if warranted.

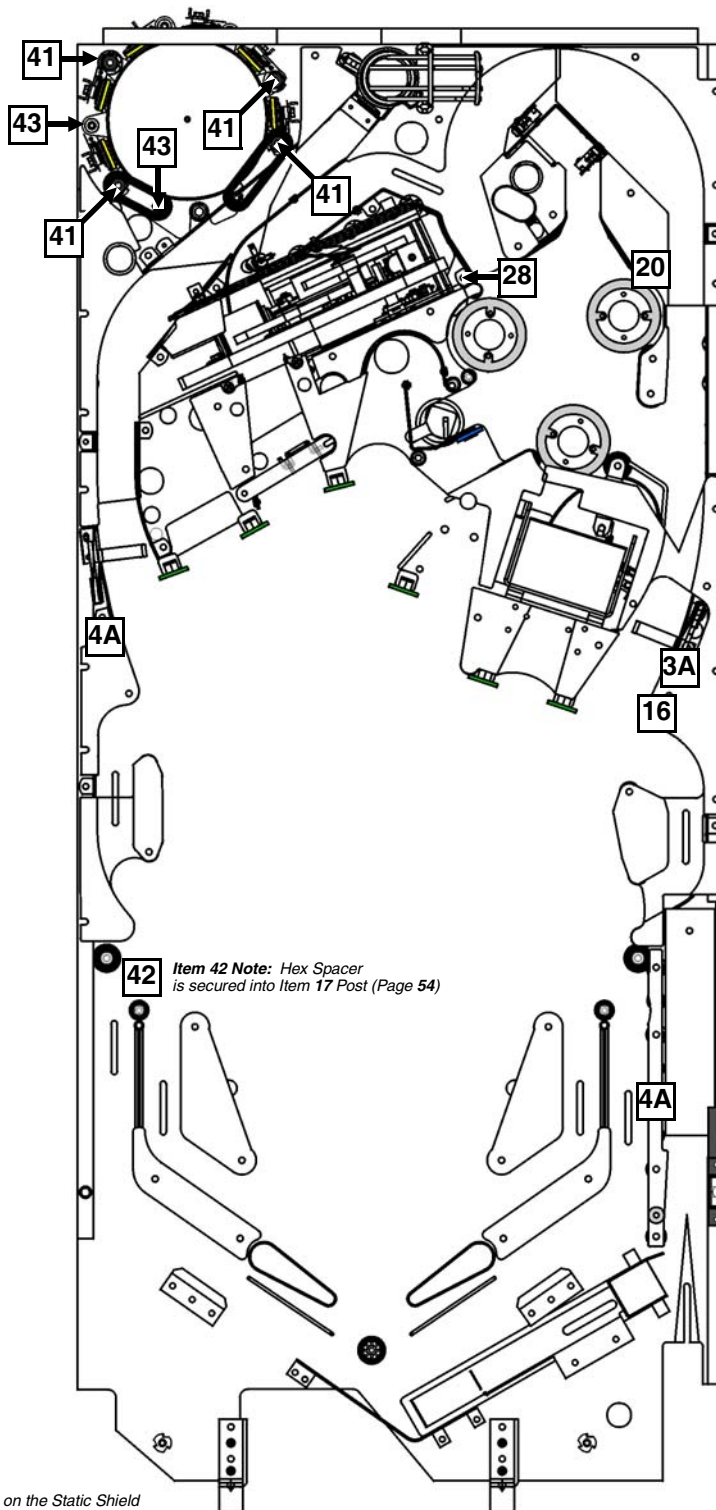

- 3A** *Item 3A Note: Quantity 4 on the Static Shield located on the Speaker Panel; Quantity 1 on the Display Controller PCB (both in Backbox).*
- 5** *Item 5 Note: Quantity 1 on the Dot Matrix Display (in Backbox).*

**Take Note:**

**Legend Note:**  
Items noted with a white square  are Hex Spacers.

**Sec. 4: Parts Id. ...**



# Playfield Top - Plastic Posts & Spacers & Metal Spacers (Actual Size) †

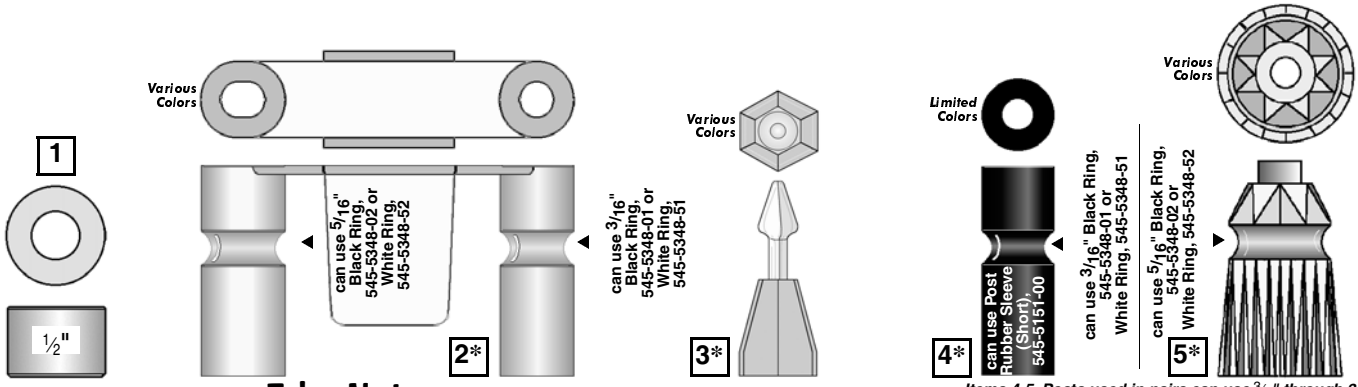

**Take Note:**

## PLASTIC PART COLOR CHART

Nr.	Color	Nr.	Color	Nr.	Color
-00	Black	-06	Yellow	-12	Fluor. Blue
-01	Clear	-07	Orange	-13	Teal Green
-02	Red	-08	White	-14	Gray
-03	Amber	-09	Purple	-15	Luminescent
-04	Green	-10	Fluor. Orange	-16	Gold
-05	Blue	-11	Fluor. Green		

\* Items 2 - 5 come in various colors (may not be available in every color). Item 4 is currently only available in the color(s) stated in this game manual (other colors used in prior games may no longer be available). The "-XX" or last 2-Digits in Part N<sup>o</sup>s which come in various colors, should be replaced with the desired 2-Digit N<sup>o</sup> from the above Color Chart. Some colors may no longer be available for desired item.

- ♦ Spacer .39" I.D. X .5" O.D. X .35" Lg. (254-5048-00): See Item 8, Page 79.
- ❖ Spacer .26" I.D. X .38" O.D. X .47" Lg. (254-5047-00): See Sail Linkage Exploded View, Page 82.

**Take Note:**

If any one of Items 11-23 Plastic Spacers is not available in the size required, order the smaller sized spacers together to stack sizes together until appropriate size is achieved (e.g. If 1 1/8" is needed but unavailable, order a 1/2" + 5/8" & stack to = 1 1/8").

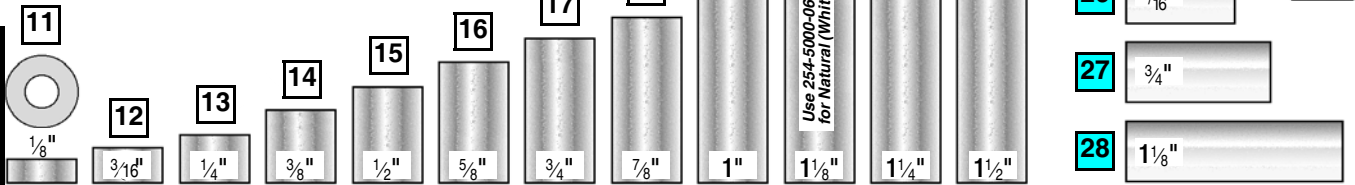

Nr.	PLASTIC POSTS & SPACERS	QTY.	SPI PART Nr.	Nr.	PLASTIC POSTS & SPACERS	QTY.	SPI PART Nr.
1	3/8" X 1/2" Metal Spacer		530-5099-00	14	3/8" X 3/8" Plastic Spacer Gray	2	254-5000-12
2**	Top Lane Plastic Mini-Lite Hood (Blue)	2	550-5061-05	15	1/2" X 3/8" Plastic Spacer Gray	2	254-5000-01
Item 2 typically secured by: #6-32 X 1-3/4" PPH MS (Zinc) (Qty. 2/per) (237-5511-00) and Washer 9/64" X 5/16" OD X 1/32" (Qty. 2/per) (242-5017-00), if used.				16	5/8" X 3/8" Plastic Spacer Gray	5	254-5000-14
3**	Mini-Jewel Plastic Post (Clear)	4	550-5052-01	17	3/4" X 3/8" Plastic Spacer Gray		254-5000-07
Item 3 typically secured by: #6 X 3/8" HWH AB (Zinc) (Qty. 1/per) (234-5000-00)				18	7/8" X 3/8" Plastic Spacer Gray		254-5000-11
4**	1 1/16" 1-Groove Plastic Post (Black)		550-5059-00	19	1" X 3/8" Plastic Spacer Gray or Black		254-5000-04
	1 1/16" 1-Groove Plastic Post (Clear)	25	550-5059-01	20	1 1/8" X 3/8" Plastic Spacer Gray		254-5000-06
5**	1-Groove Jewel Plastic Post (Clear)	2	550-5034-01		1 1/8" X 3/8" Plastic Spacer Natural		254-5000-06N
Items 4 & 5 typically secured by: Post Fastening Screw #6-32 Top / #6-32 Bottom (Qty. 1/per) (530-5012-02, Item 6 Page 69).				21	1 1/4" X 3/8" Plastic Spacer Gray	2	254-5000-05
6 ‡	1/4" Slf. Rtn. Plastic Spacer White		254-5007-02	22	1 1/2" X 3/8" Plastic Spacer Gray	2	254-5000-08
7 ‡	3/8" Slf. Rtn. Plastic Spacer White		254-5007-01	23	1 5/16" X 3/8" Plastic Spacer Gray		254-5000-15
8 ‡	5/8" Slf. Rtn. Plastic Spacer White		254-5007-00	24	1/4" X 5/16" X .144" I.D. Metal Spacer		254-5014-03
9 ‡	3/4" Slf. Rtn. Plastic Spacer White		254-5007-03	25	1/2" X 5/16" X .144" I.D. Metal Spacer		254-5014-00
10	1/2" X 1/4" Plastic Spacer White (Narrow)		254-5000-03	26	9/16" X 5/16" X .144" I.D. Metal Spacer		254-5014-04
11	1/8" X 3/8" Plastic Spacer Gray		254-5000-19	27	3/4" X 5/16" X .144" I.D. Metal Spacer		254-5014-01
12	3/16" X 3/8" Plastic Spacer Gray	2	254-5000-18	28	1 1/8" X 5/16" X .144" I.D. Metal Spacer		254-5014-02
13	1/4" X 3/8" Plastic Spacer Gray	7	254-5000-02	29	1" X 5/16" X .144" I.D. Metal Spacer		254-5001-00
				30 ‡	7/8" Plastic Spacer Support (Dual-Locking)		254-5039-14

† The item type (size / description), the quantity and/or location used, are subject to change without notice. Service Bulletins will announce any changes, if warranted.

Sec. 4: Parts Id. ...



The item type (size / description), the quantity and/or location used, are subject to change without notice. Service Bulletins will announce any changes, if warranted.

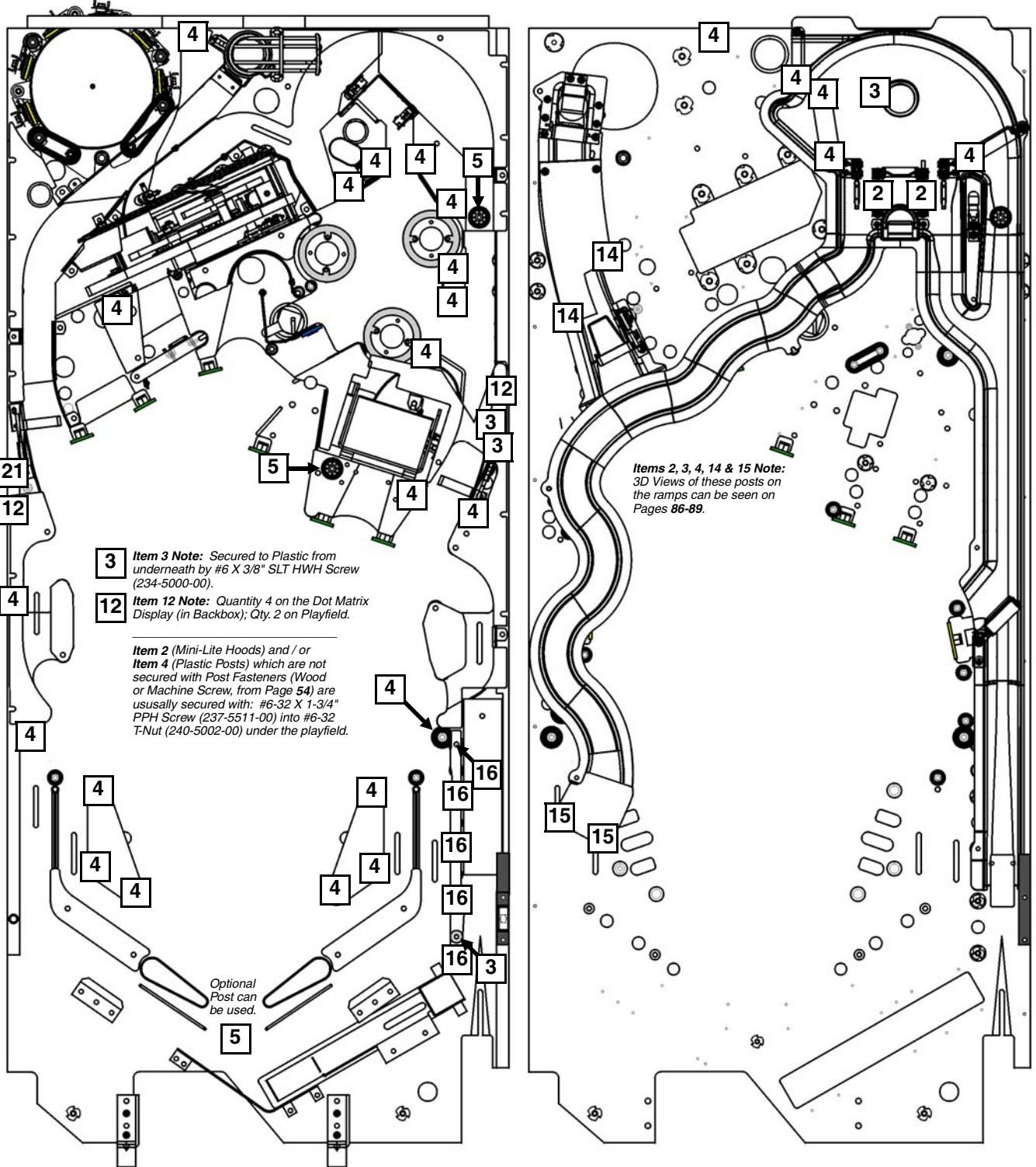

- 3 **Item 3 Note:** Secured to Plastic from underneath by #6 X 3/8" SLT HWH Screw (234-5000-00).
- 12 **Item 12 Note:** Quantity 4 on the Dot Matrix Display (in Backbox); Qty. 2 on Playfield.

**Item 2 (Mini-Lite Hoods) and / or Item 4 (Plastic Posts)** which are not secured with Post Fasteners (Wood or Machine Screw, from Page 54) are usually secured with: #6-32 X 1-3/4" PPH Screw (237-5511-00) into #6-32 T-Nut (240-5002-00) under the playfield.

Optional Post can be used.

**Take Note:**

**Legend Note:**  
 Items noted with a white square  are Plastic Posts & Spacers.  
 Items noted with a cyan square  are Metal Spacers.

Sec. 4: Parts Id. ...



# Playfield Top & Bottom - Rubber Parts Black & Blue (Rings Actual Size) †

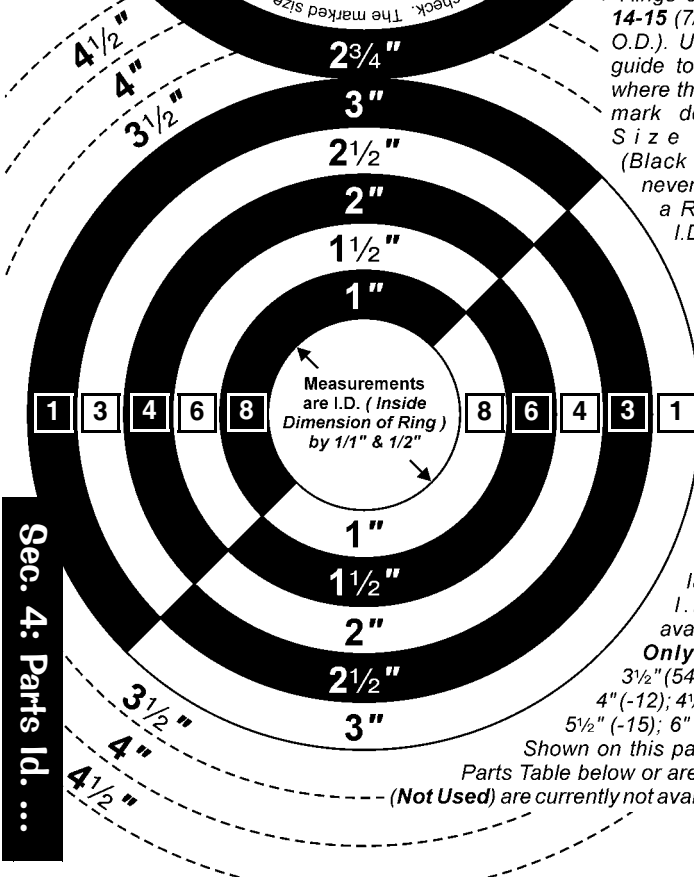
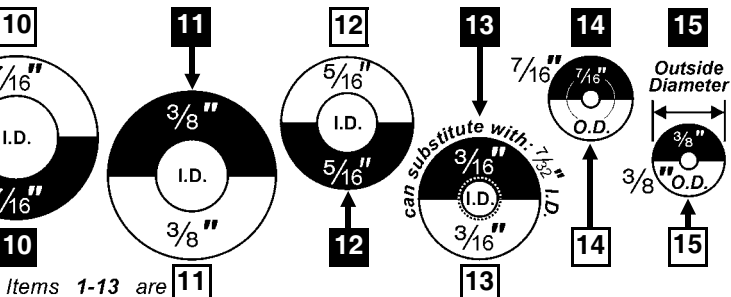
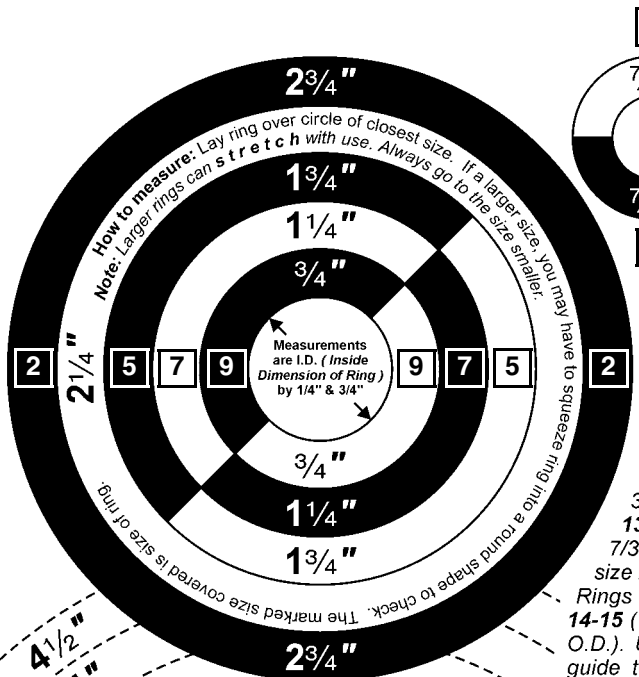

Items 1-13 are measured by the Inside Diameter (I.D.). Items 1-9 and 11 are approximately 1/4" thick. Items 10, 12-15 are approximately 3/16" thick. Item 13 can also be a 7/32" I.D. Ring. The size is imprinted on all Rings except for Items 14-15 (7/16" O.D. & 3/8" O.D.). Use this page as a guide to measure rings where the size imprint or mark does not exist. Size 2 1/4" I.D. (Black or White) was never used. Choose a Ring Size +/- 1/4" I.D. if required.

Note: Sizes larger than 3" I.D. currently available in Black Only (Not Used): 3 1/2" (545-5348-11); 4" (-12); 4 1/2" (-13); 5" (-14); 5 1/2" (-15); 6" (-16). Sizes Not Shown on this page, listed in the Parts Table below or are noted with N/U (Not Used) are currently not available.

Nr.	RUBBER RINGS	QTY.	SPI PART Nr.
1	3" I.D. Rubber Ring BLACK		545-5348-10
	3" I.D. Rubber Ring WHITE		545-5348-60
2	2 3/4" I.D. Rubber Ring BLK		545-5348-20
	2 3/4" I.D. Rubber Ring WHT	N/U	545-5348-70
3	2 1/2" I.D. Rubber Ring BLK	2	545-5348-09
	2 1/2" I.D. Rubber Ring WHT		545-5348-59
4	2" I.D. Rubber Ring BLACK		545-5348-08
	2" I.D. Rubber Ring WHITE		545-5348-58
5	1 3/4" I.D. Rubber Ring BLK	1	545-5348-21
	1 3/4" I.D. Rubber Ring WHT	N/U	545-5348-71
6	1 1/2" I.D. Rubber Ring BLK		545-5348-07
	1 1/2" I.D. Rubber Ring WHT		545-5348-57
7	1 1/4" I.D. Rubber Ring BLK	1	545-5348-06
	1 1/4" I.D. Rubber Ring WHT		545-5348-56
8	1" I.D. Rubber Ring BLACK	3	545-5348-05
	1" I.D. Rubber Ring WHITE		545-5348-55
9	3/4" I.D. Rubber Ring BLACK	6	545-5348-04
	3/4" I.D. Rubber Ring WHITE		545-5348-54
10	7/16" I.D. Rubber Ring BLK		545-5348-18
	7/16" I.D. Rubber Ring WHT		545-5348-68
11	3/8" I.D. Rubber Ring BLACK		545-5348-03
	3/8" I.D. Rubber Ring WHITE	N/U	545-5348-53
12	5/16" I.D. Rubber Ring BLK	4	545-5348-02
	5/16" I.D. Rubber Ring WHT		545-5348-52
13	3/16" I.D. Rubber Ring BLK	6	545-5348-01
	3/16" I.D. Rubber Ring WHT		545-5348-51
14	7/16" O.D. Rubber Ring BLK	56	545-5348-17
	7/16" O.D. Rubber Ring WHT		545-5348-67
	Note: Item 14, 7/16" O.D. Black Rings (Qty. 41 of 56) are used to cushion the Bayonet Sockets under the playfield (between bracket & playfield).		
15	3/8" O.D. Rubber Ring BLK		545-5348-19
	3/8" O.D. Rubber Ring WHT		545-5348-69
16	Small Flipper BLACK Ring (Soft Duro)		545-5207-00
	Small Flipper RED Ring (Soft Duro)		545-5207-22
	Large Flipper BLACK Ring (50 Duro)	2	545-5277-00
	Large Flipper YELLOW Ring (50 Duro) (use -06 40 Duro)		545-5277-04
17	Large Flipper WHITE Ring (50 Duro)		545-5277-08
	Large Flipper RED Ring (Soft Duro)		545-5277-22
18	O-Ring 11/32" I.D. X 7/32" O.D. X 1/16"	2	545-5850-00
	(Located inside Cabinet with each Flipper Button Assembly)		

Sec. 4: Parts Id. ...

† The item type (size / description), the quantity and/or location used, are subject to change without notice. Service Bulletins will announce any changes, if warranted.

Nr.	RUBBER BUMPER PADS	QTY.	SPI PART Nr.
A*	Bumper BLK Pad (Lg. w/ grommet)	2	545-5428-00
	Item B are located on Flipper Assemblies. See next page for location.		
B*	Bumper BLK Pad (Sm. w/ grommet)	5	545-5105-00
	Item B are located on multiple assemblies. See next page for location.		
C*	Bmpr. BLUE Pad (.88" Top / .7" Bot. 1" Ht.)	1	626-5067-00
	Item C : For view of how it is used, see the Flat Rail #12 on Page 93.		
Nr.	RBR. BUMPER POST SLVS.	QTY.	SPI PART Nr.
D*	Bumper BLACK Post Sleeve (Tall)	9	545-5308-00
	Item D in RED use 545-5308-22; Item D in WHITE use 545-5308-08.		
E*	Bumper Post Sleeve (Short)		545-5151-00

### Take Note:

\* An asterisk (\*) indicates view of item on the Assembly Drawing only (for location see next page). For better view(s), see Drawings for Major Assemblies... (The Blue Pages), Section 4, Chapter 2, (Page 65), (view Table of Contents for exact page).

Legend Note:  
 Items noted with a black square ■ are Black Rubber Parts.  
 Items noted with a white square □ are White Rubber Parts.  
 Items noted with a blue square ■ are Blue Rubber Parts.



† The item type (size / description), the quantity and/or location used, are subject to change without notice. Service Bulletins will announce any changes, if warranted.

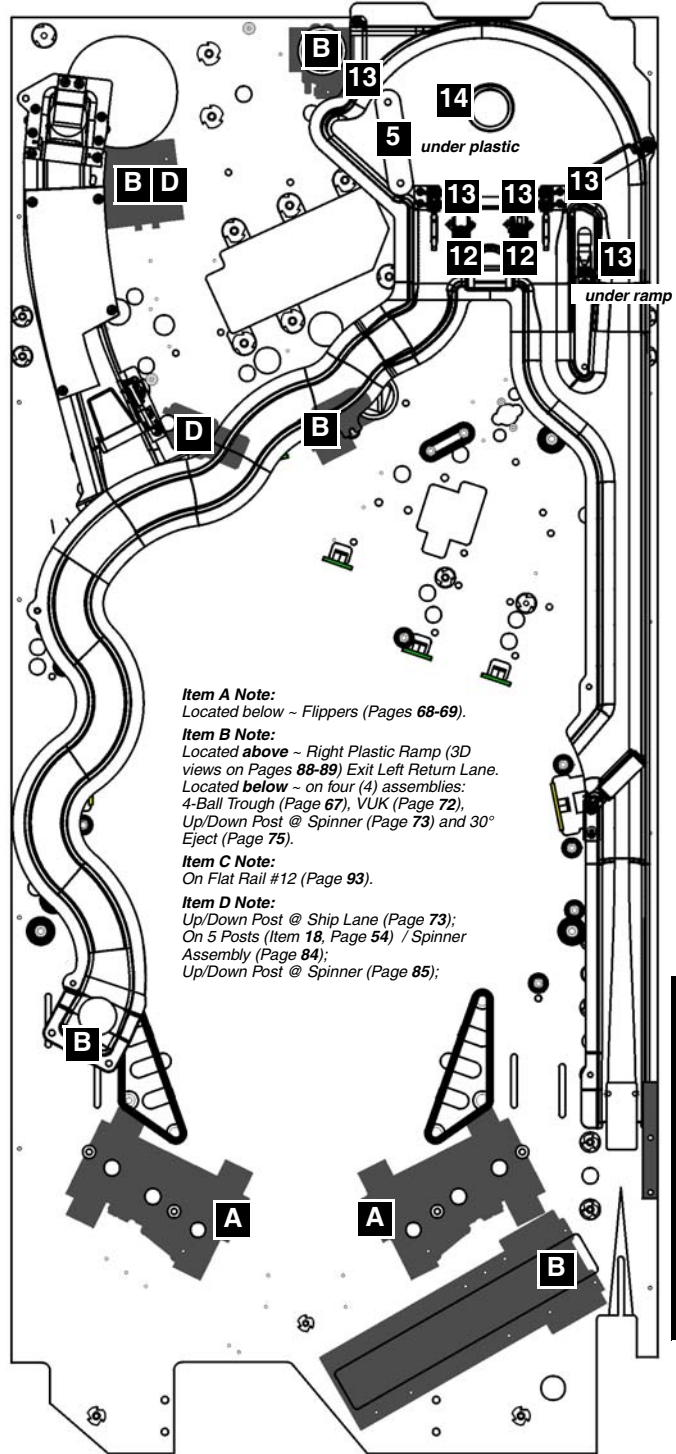
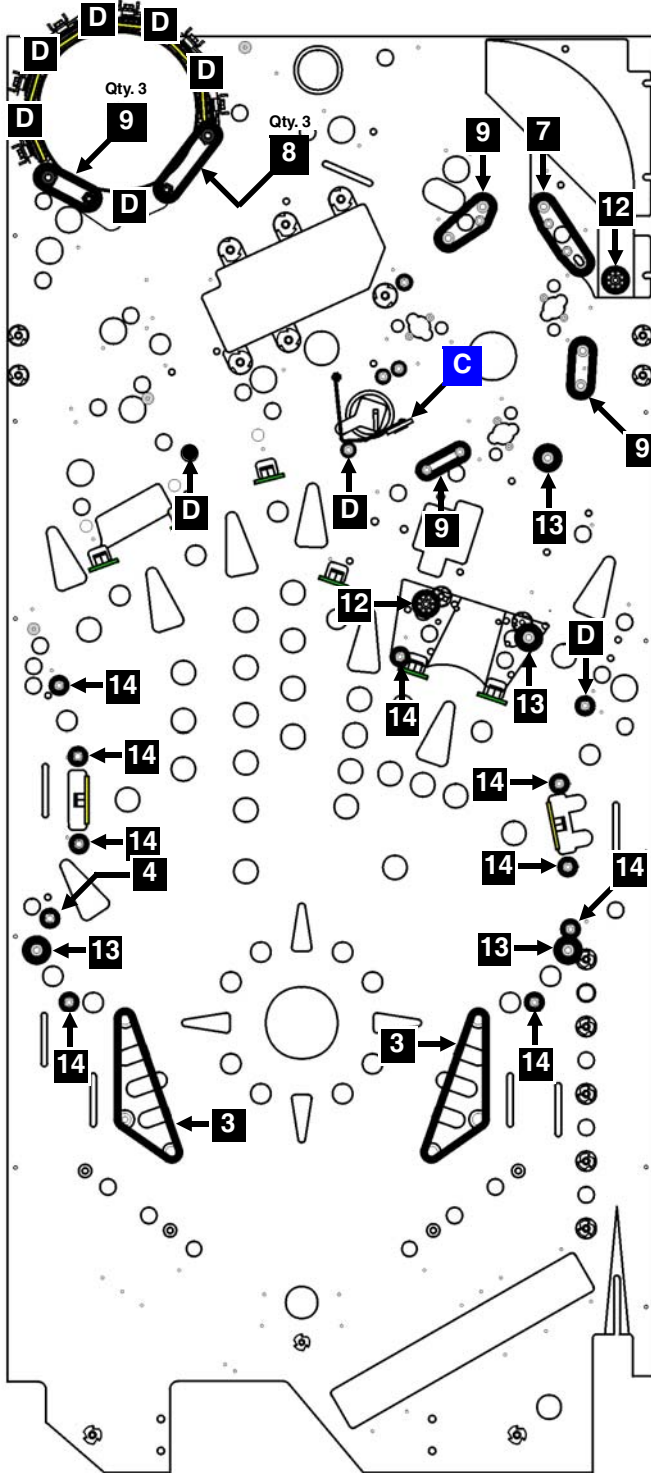

- Item A Note:**  
Located below ~ Flippers (Pages 68-69).
- Item B Note:**  
Located above ~ Right Plastic Ramp (3D views on Pages 88-89) Exit Left Return Lane.  
Located below ~ on four (4) assemblies:  
4-Ball Trough (Page 67), VUK (Page 72),  
Up/Down Post @ Spinner (Page 73) and 30°  
Eject (Page 75).
- Item C Note:**  
On Flat Rail #12 (Page 93).
- Item D Note:**  
Up/Down Post @ Ship Lane (Page 73);  
On 5 Posts (Item 18, Page 54) / Spinner  
Assembly (Page 84);  
Up/Down Post @ Spinner (Page 85);

**Take Note:**

**Legend Note:**  
Items noted with a black square ■ are Black Rubber Parts.  
Items noted with a white square □ are White Rubber Parts.  
Items noted with a blue square ■ are Blue Rubber Parts.

Sec. 4: Parts Id. ...



# Playfield Top & Bottom - Small Bayonet Sockets & Bulbs ■ (Actual Size) †

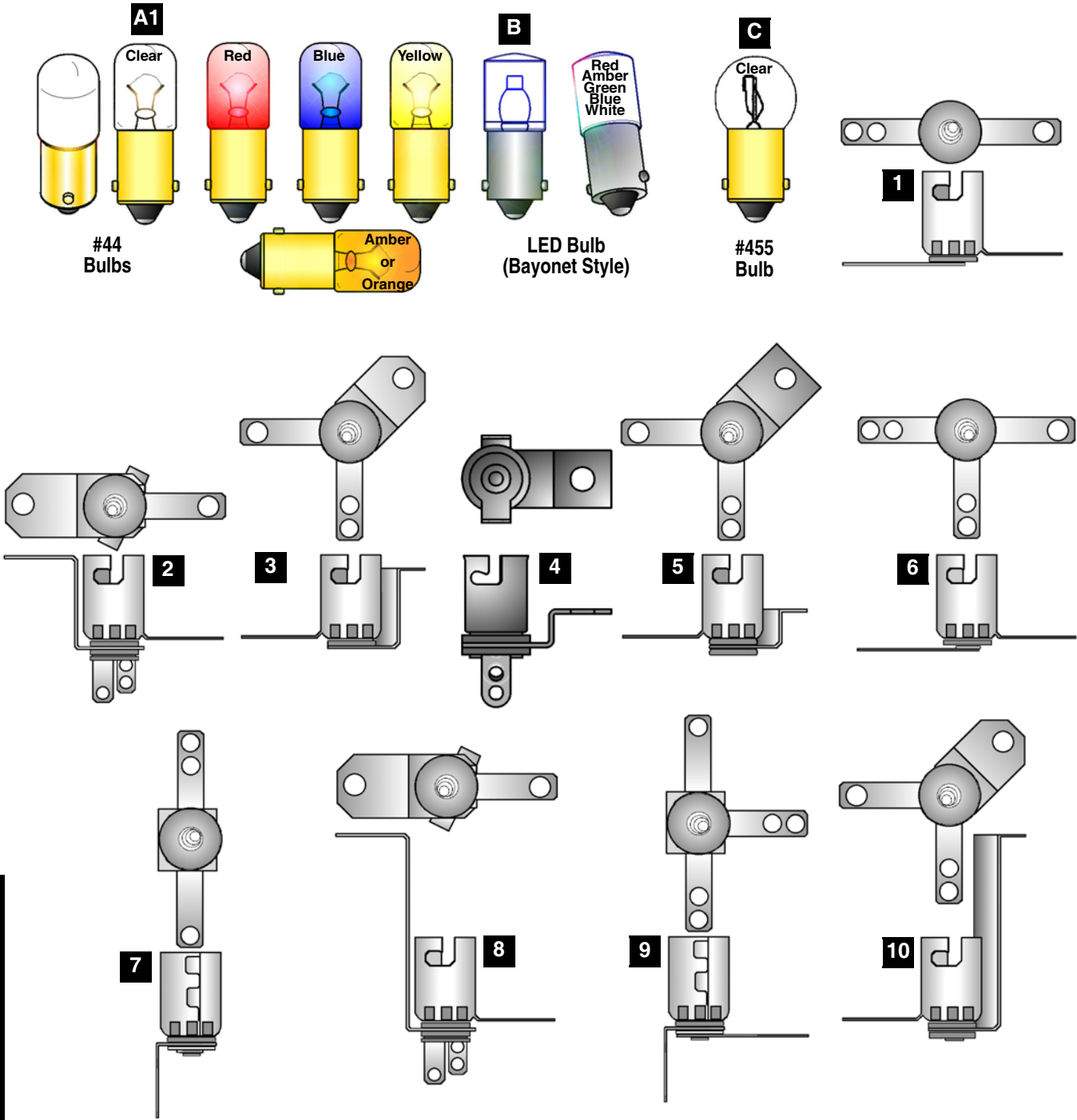

Sec. 4: Parts Id. ...

† The item type (size / description), the quantity and/or location used, are subject to change without notice. Service Bulletins will announce any changes, if warranted.

Nr.	BULBS (#44)	QTY.	SPI PART Nr.	Nr.	BULBS (LED & #455)	QTY.	SPI PART Nr.
A	#44 Bulb (Clear) Heavy Filament	52	165-5000-44-HF	B	LED Module (WHT) (12.8v 20-25mA) Bynt.		112-5023-08
	#44 Bulb (Red use -02; Green use -04)	10	165-5053-XX-HF	<i>Item B Note: Different Colors available (not used in this game) ~ Red (112-5023-02); Amber (112-5023-03); Green (112-5023-04); Blue (112-5023-05);</i>			
<i>Item A Note: Different Colors available ~ Red (165-5053-02-HF); Amber (165-5053-03-HF); Blue (165-5053-05-HF); Orange (165-5053-07-HF)</i>				C	#455 Twinkle Bulb		165-5003-00

  

Nr.	SMALL BAYONET SOCKETS	QTY.	SPI PART Nr.	Nr.	SMALL BAYONET SOCKETS	QTY.	SPI PART Nr.
1	2-Lug Staple Down Socket	14	077-5000-00	9	3-Lug Laydown Socket (3 Lugs Flat)		077-5006-00
2	3-Lug Stand-Up Socket (Med. Brkt.)		077-5008-00	10	2-Lug Stand-Up Socket (Tall Bracket)		077-5005-00
3	2-Lug Stand-Up Socket (Med. Brkt.)	2	077-5002-00	11	3-Lug Stand-Up Long Shell Socket		077-5013-00
4	2-Lug Stand-Up Socket (Short Brkt.)	1	077-5223-00	12	2-Lug Stand-Up Lg. Shell Socket (Gls)	2	077-5031-00
5	2-Lug Stand-Up Sckt. (Short Bracket)		077-5002-31	13	1-Lug S-U Lg. Shell Sckt. (Med. Brkt.)		077-5012-00
6	3-Lug Staple Down Socket	10	077-5001-00	14	3-Lug S-U Lg. Shell Sckt. (45° Brkt.)		077-5035-00
7	2-Lug Laydown Socket	1	077-5003-00	15	3-Lug Laydown Socket (2 Lugs Bent)	1	077-5032-00
8	3-Lug Stand-Up Socket (Tall Bracket)		077-5009-00				



Playfield Top & Bot. - Small Bayonet Sockets & Bulbs ■ (Actual Size) † Continued

† The item type (size / description), the quantity and/or location used, are subject to change without notice. Service Bulletins will announce any changes, if warranted.

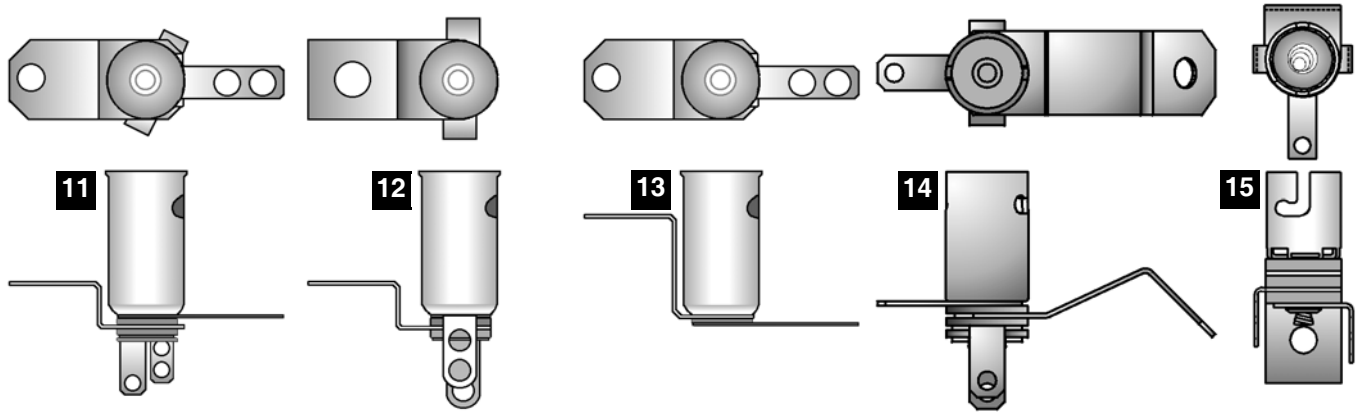

Playfield Bottom - Large Bayonet Sockets & Bulbs ■ (Actual Size) †

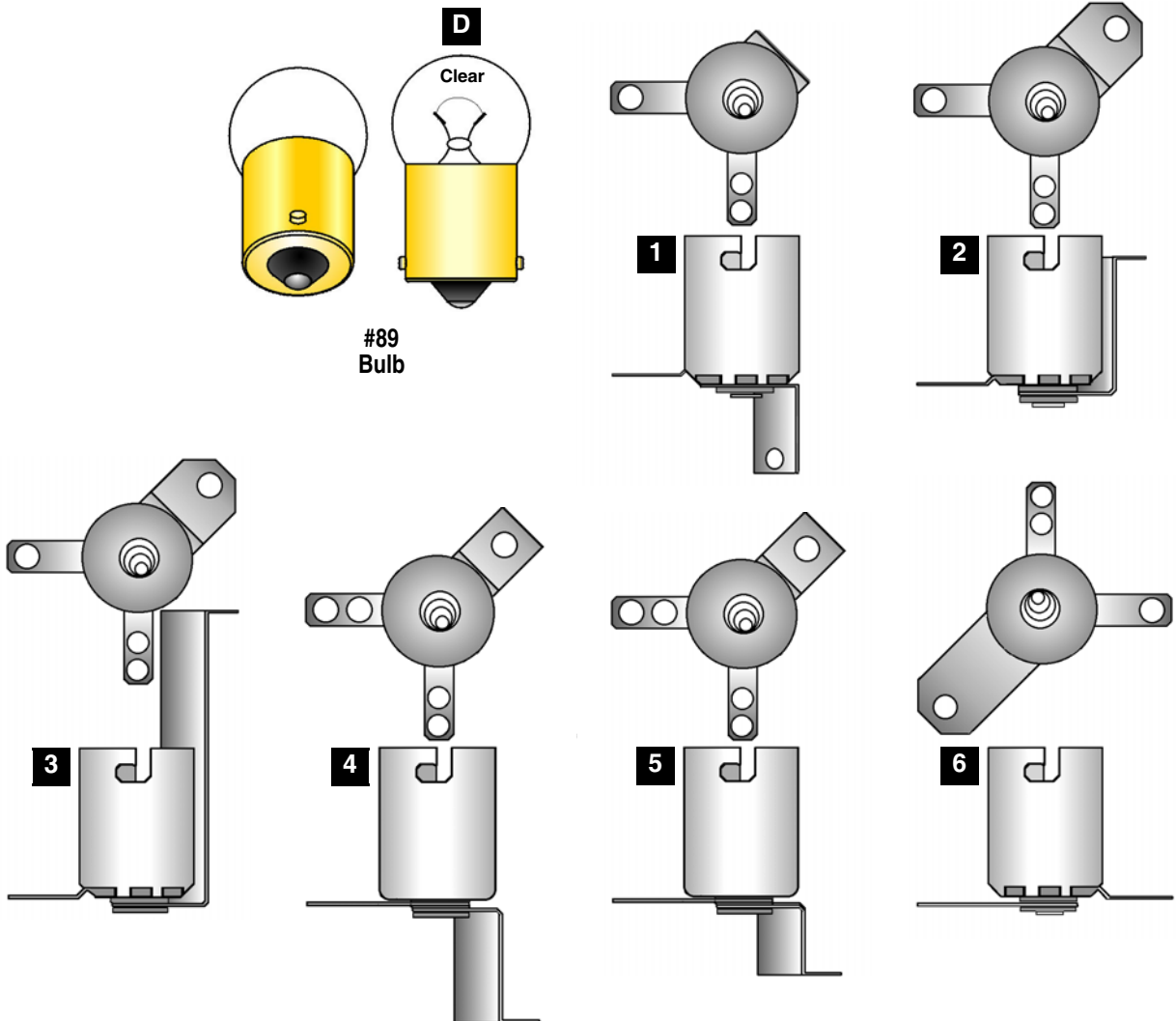

Nr.	BULBS (#89)	QTY.	SPI PART Nr.
D	#89 Bulb Heavy Filament	9	165-5000-89-HF

Nr.	LARGE BAYONET SOCKETS	QTY.	SPI PART Nr.	Nr.	LARGE BAYONET SOCKETS	QTY.	SPI PART Nr.
1	2-Lug Laydown Standard Socket	1	077-5100-00	4	2-Lug Stand-Up Rev. Mount Socket		077-5103-00
2	2-Lug Stand-Up Short Socket	6	077-5101-00	5	2-Lug Stand-Up Rv. Mnt. Short Socket		077-5106-00
3	2-Lug Stand-Up Long Socket	1	077-5102-00	6	2-Lug Straight Leg Socket		077-5107-00

Sec. 4: Parts Id. ...



# Playfield Top & Bottom - Wedge Base Sockets & Bulbs (Actual Size) †

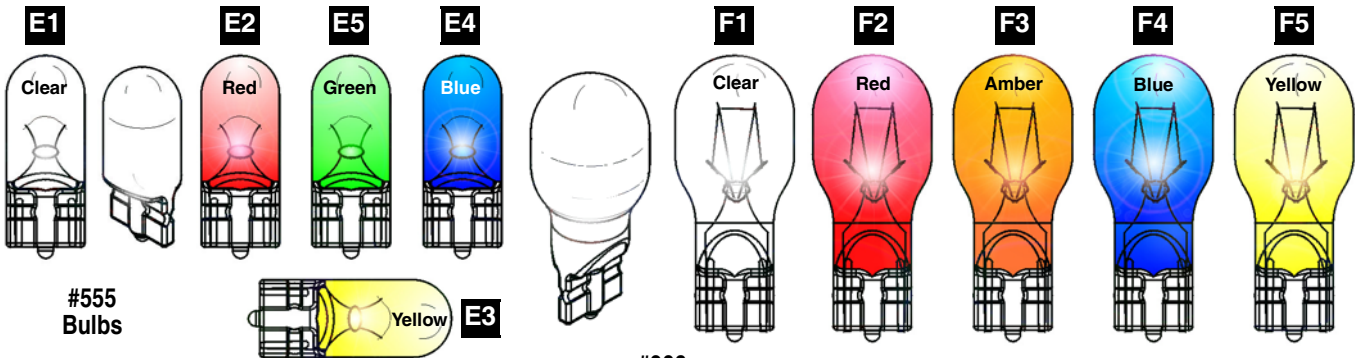

Note: Always replace with same type bulb in original application.

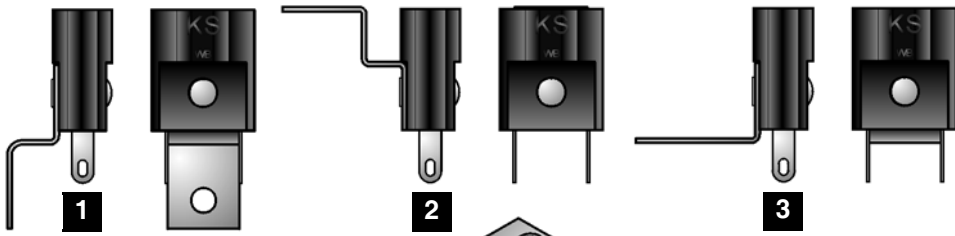

LED Bulb (Wedge Base)

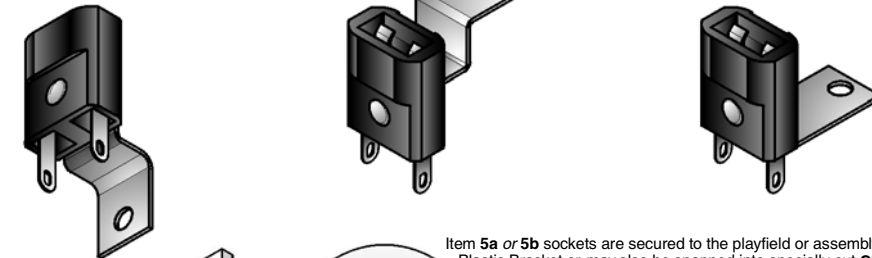

Item 5a or 5b sockets are secured to the playfield or assembly by Item 5c Plastic Bracket or may also be snapped into specially cut Clear and / or Screened Plastic Pieces or Metal Brackets (used for multiple mounting of sockets when positioned closely together or in tight areas). If Plastic Pieces or Metal Brackets are used to mount Item 5a or 5b Sockets, it will be noted on Playfield Bottom - Miscellaneous Parts and Brackets, page earlier in this Chapter.

Item 5a is a solderless IDC (Insulation Displacement Connection) Socket with a built-in Diode, 1N4003 (112-5003-00) (can be replaced with 1N4001 Diode, 112-5001-00). Item 5b Socket (Yellow) is identical to 5a (Socket) except it does NOT REQUIRE a diode (Flash Lamp usage).

Item 4 Socket does not require brackets. Old stock may include "L" style brackets (each side); do not secure to assembly. Black Wires (Qty. 2) are 12" each.

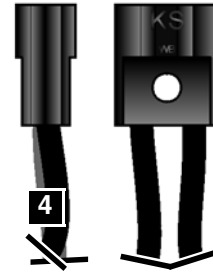

4

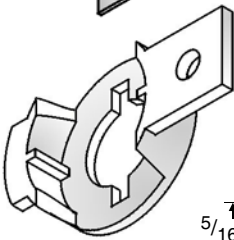

5/16"

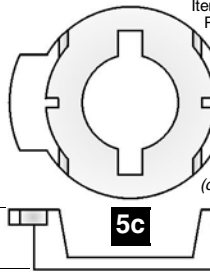

5c

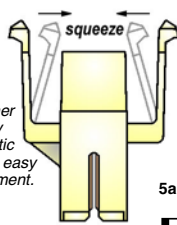

Just squeeze the "side arms" of the socket together and pull away from the plastic or bracket for easy Bulb replacement.

5a

5a only

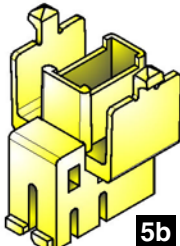
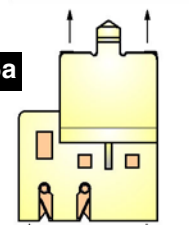

5b is Yellow with No Diode

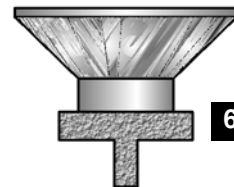

6

Sec. 4: Parts Id. ...

Nr.	BULBS (#555 & LED)	QTY.	SPI PART Nr.	Nr.	BULBS (#906)	QTY.	SPI PART Nr.
E1	#555 Wedge Base Bulb (Clear)	63	165-5002-00	F	#906 Wedge Base Bulb (Clear)		165-5004-00
E2-E5	#555 Wedge Base Bulb (Multi-Color)		165-5054-XX	Item F Note: Different Colors available (not used in this game) - Red (165-5004-02); Amber (165-5004-03); Blue (165-5004-05); Yellow (165-5004-06) Ordering Note: C86 / CM86 / #86 6.3V Mini-Wedge Base Bulb (Clear) used inside the Tournament Button (as described in Section 4, Chapter 1, (The Pink Pages) Parts Identification & Location, Cabinet - Parts & Switches, Item 11T), use Part Number 165-5002-01. Neon Bulb (Spike Suppression / Connector for Motors) NE-2 (A1A), use PN 165-5021-00.			
E6	LED Module (WHT) (5v - 6.3v) Wedge Base	3	112-5024-08	Item E6 Bulb Note: Typically used with Item 4 Socket in Pop Bumpers.			

Nr.	WEDGE BASE SOCKETS	QTY.	SPI PART Nr.	Nr.	WEDGE BASE SOCKETS	QTY.	SPI PART Nr.
1	Wedge Base Socket (Laydown)	1	077-5026-01	5a	IDC Snap-On Socket (Biege)	60	077-5216-00
2	Wedge Base Socket (Offset)		077-5029-00	5b	IDC Snap-On Socket <b>No Diode</b> (Yel.)		077-5216-01
3	Wedge Base Socket (Laydown GI)		077-5030-00	5c	5/16" Ht. Bracket (White)		545-5760-18
4	W.B. Socket (Bumpers/Special App.)	3	077-5206-00	6	Light Reflector (Silver Plastic)		545-5409-01

Note Item 6: Typically used with Item 1 (but will fit on any similar Wedge Base Socket).

† The item type (size / description), the quantity and/or location used, are subject to change without notice. Service Bulletins will announce any changes, if warranted.





**Drawings for Major Assemblies & Ramps (The Blue Pages)**

**Table of Contents  
for Section 4, Chapter 2 of 2**

**Table of Contents for Section 4, Chapter 2 ..... 65**

**Ball Shooter (Plunger) Assembly, 500-6146-00-04..... (Top) 66**  
 ▶ Assembly View ▶ Ball Shooter Parts Table

**Autoplunger Arm Weld Assembly, 500-6091-00 Autoplunger Coil Assembly, 500-6092-03-ND  
 and Shooter Lane Switch Assembly, 500-6096-00 ..... (Bot) 66**

**4-Ball Trough Assembly, 500-6318-14-ND ..... 67**  
 ▶ Associated Parts: Ball Trough Enter/Exit Scoop, 535-7329-01; Steel Balls (1-1/16" ø), 260-5000-00

**Flipper (Left) Assembly, 500-6543-14-ND ..... 68**  
 ▶ Associated Parts: WHITE Flipper Bat & Shaft Asm., 515-5133-08-06; Large Flipper BLACK Rubber Ring, 545-5277-00

**Flipper (Right) Assembly, 500-6543-04-ND ..... 69**  
 ▶ Associated Parts: WHITE Flipper Bat & Shaft Asm., 515-5133-08-06; Large Flipper BLACK Rubber Ring, 545-5277-00

**Slingshot (Left & Right) Assemblies, 500-5849-00-ND (Qty. 2) ..... 70**

**Bumper Top, Bumper Bottom & Bumper Switch Individual Parts Only ..... 71**  
 ▶ Associated Part: Bumper [Pop] Cap (Red), 550-5057-02 (Qty. 3)

**VUK (at top edge of playfield) Assembly, 500-6867-01 ..... 72**

**Ball Deflector (Ship Pin Lane Lock/Up Post) Assembly, 500-6657-00-ND ..... 73**

**Up/Down Post (Treasure Chest Ball Lock) Assembly, 500-5867-12-ND ..... 74**

**Bumper Eject (30°) Assembly, 500-6511-01-ND ..... 75**  
 ▶ Associated Part: Switch (Eject) Assembly, 500-6520-01)

**Treasure Chest Assembly, Individual Parts Only ..... 76-76**

**Kraken Plastic Assembly included in Plastic Kit, 803-5000-92 (assembled as shown) ..... 78**

**Pirate Ship Mechanical Assembly, Individual Parts Only ..... 79-83**

**Motor & Frame Assembly, Individual Parts Only ..... 80-81**

**Pirate Ship Removal / Dissassembly Procedure ..... 83**

**Spinning Disk Assembly, Individual Parts Only ..... 84**

**Spinning Disk Up/Down Post Assembly & Cover, Individual Parts Only ..... 85**

**Left Plastic Ramp, Individual Parts Only ..... 86**

**Reverse-O-Matic (Scoop) Assembly, Individual Parts Only & Right Wire Ramp ..... 87**

**Right Plastic Ramp Assembly, Individual Parts Only ..... 88-89**

**Right Plastic Ramp & VUK Tube Wire Ramp Removal Overview ..... 90**

**Back Panel Assembly, Individual Parts Only ..... 91**

**Left Orbit, Under/Inside Chest 1-Way Gate and Under/Inside Chest Switch Flat Rails ..... 92**

**Under Right Ramp Top, Under Ship Left Side, ... Shit Rt. Side and ... Eject Hole Flat Rails ..... 93**

**[ Blank Page ] ..... 94**

**Sec. 4: Drawings ...**



# Ball Shooter (Plunger) Assembly, 500-6146-00-04 (Items 1-8)

Nr.	BALL SHOOTER PARTS	QTY.	SPI PART Nr.	Nr.	BALL SHOOTER PARTS	QTY.	SPI PART Nr.
1	Housing (Shooter Assembly)	1	535-5067-02	3	Comp. Spring (GREEN, .035" ø)	1	266-5001-04
Item 1 is secured to the Cabinet (not included with Item 1 or the Assembly) by: Support Plate (Qty. 1) (535-5027-00), #10-32 X 1/2" PPH (Sems) Zinc TF (Qty. 3) (237-6033-00), #10 Split Lock Washer (Qty. 3) (244-5003-00) and #6 X 1/2" HWH AB (Zinc) Red (Qty. 2) (234-5001-02)				4	Compression Spring (Short Plunger)	1	266-5010-00
2	Rod Assembly (with Black Knob)	1	515-6557-00	5	Bushing, 3/8" I.D. (Oilite)	2	280-5010-00
				6	Washer, 3/8" I.D. X 5/8" O.D. X 1/16"	3	242-5014-00

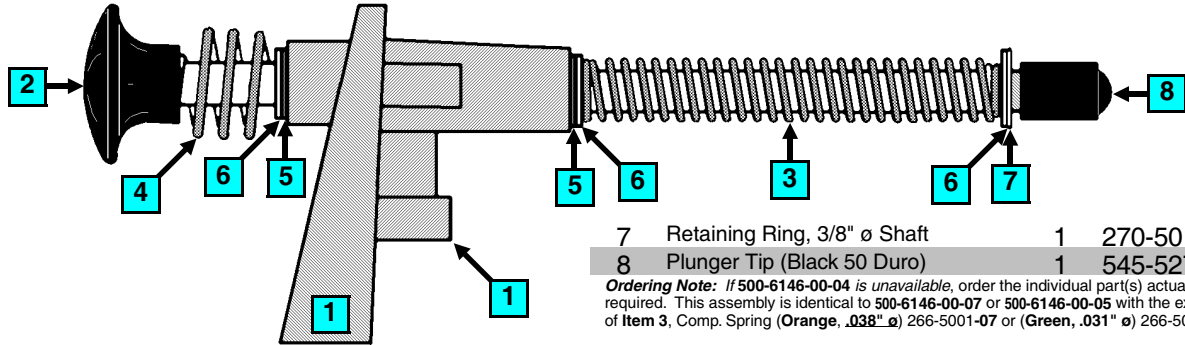

7	Retaining Ring, 3/8" ø Shaft	1	270-5012-00
8	Plunger Tip (Black 50 Duro)	1	545-5276-00

**Ordering Note:** If 500-6146-00-04 is unavailable, order the individual part(s) actually required. This assembly is identical to 500-6146-00-07 or 500-6146-00-05 with the exception of Item 3, Comp. Spring (Orange, .038" ø) 266-5001-07 or (Green, .031" ø) 266-5001-05.

## Autoplunger Arm Weld Assembly, 500-6091-00 (Items 1-5) and Autoplunger Coil Assembly, 500-6092-03-ND (Items 6-9) Shooter Lane Switch Assembly, 500-6096-00 (Items 10-12)

Nr.	AUTOPL. ARM WELD PARTS	QTY.	SPI PART Nr.	Nr.	AUTOPLNGR. COIL PARTS	QTY.	SPI PART Nr.
1	Arm Weld Assembly	1	515-6526-00	6	Autoplunger Coil Bracket Assembly	1	515-6527-00
Item 1 is secured to Item 2 by: Retaining Ring, 1/4" ø Shaft (Qty. 1) (270-5002-00)				Items 1 & 6 are secured below the P/F by: #8 X 1/2" SHWH AB (Zc.) (Qty. 9) (234-5101-00)			
2	Autoplunger Fulcrum	1	535-7697-00	7	Coil Retainer Bracket	1	535-5203-03
3	Nyliner, 1/4" (Thomson #411-FF)	2	545-5423-00	Item 7 is secured to Item 6 by: #8-32 X 1/4" PPH MS (Sems) Zinc (Qty. 2) (232-5300-00)			
4	Plunger & Link Assembly	1	515-5338-00	8	Coil, 23-800 [ NO DIODE ]	1	090-5001-ND
Item 4 is secured to Item 1 by: Retaining Ring, 1/4" ø Shaft (Qty. 1) (270-5002-00)				COIL DOES NOT REQUIRE A DIODE. SEE ⚡ COIL NOTE BELOW FOR DETAILS.			
For Individual Items use: Plunger 2" Lg. (530-5025-01), Plunger Link (545-5293-00) and Roll Pin 1/8" ø x 5/8" Lg. (251-5008-00)				9	Coil Sleeve	1	545-5031-00
5	Compression (Return) Spring	1	266-5020-00	(ASM. REF. 500-6092-03-ND, Items 6-9)			
(ASM. REF. 500-6091-00, Items 1-5)							

Nr.	SWITCH PARTS	QTY.	SPI PART Nr.
10	Switch (for Shooter Lane)	1	180-5157-00
Switch has a Diode (1N4004) (112-5003-00). Can be replaced with (1N4001) (112-5001-00).			
11	Switch Mounting Bracket	1	535-6173-00
Item 11 is secured to Playfield by: #6 X 1/2" SLT HWH AB (Zinc) (Qty. 2) (234-5001-02)			
12	Switch Body Protect Plate	1	535-6539-00
Item 12 is secured to Items 10-11 by: #2-56 X 1/2" Unslotted Ser. HWH #4 Head TR3 Black (Qty. 2) (237-5937-02) and #2-56 Hex Nut (Qty. 2) (240-5301-0)			
(ASM. REF. 500-6096-00, Items 10-12)			

Sec. 4: Drawings ...

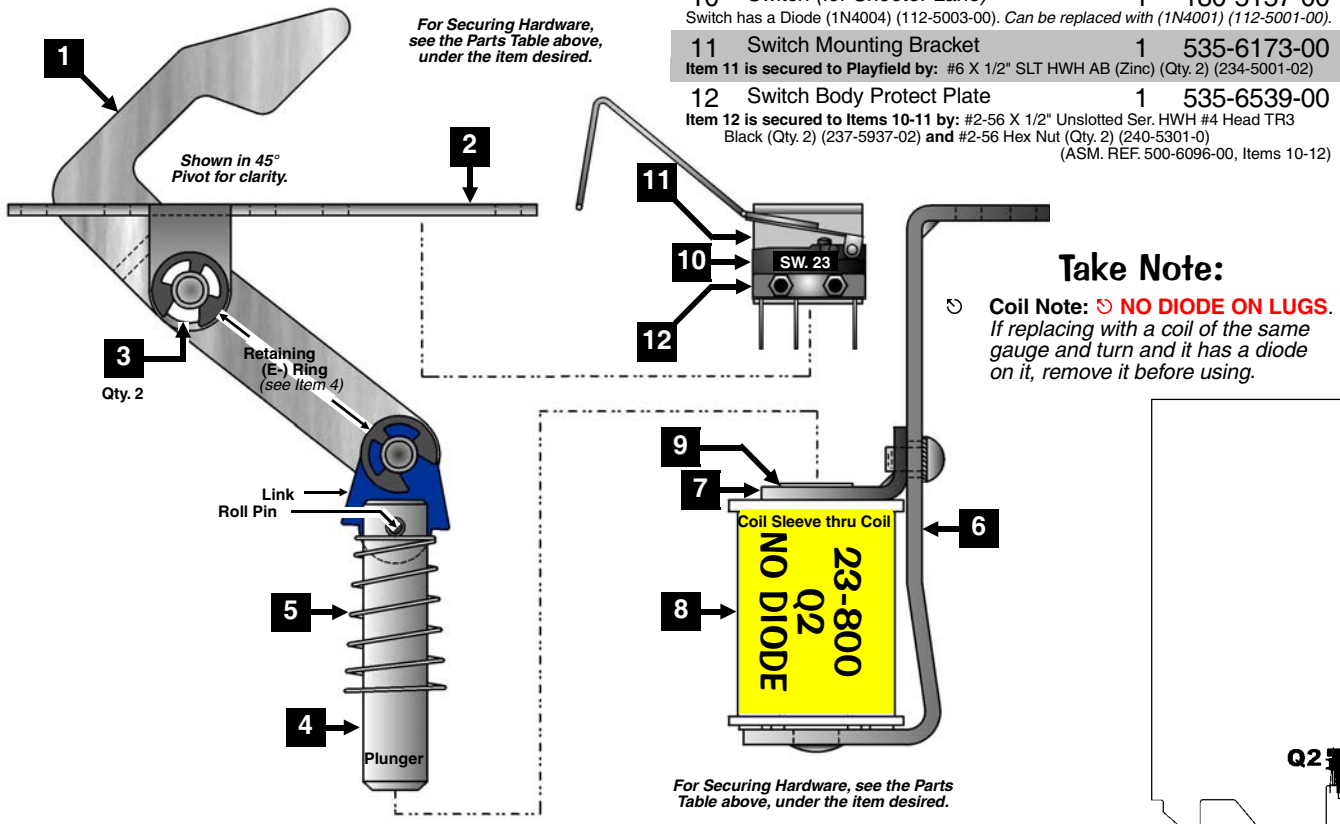

**Take Note:**  
⚡ **Coil Note:** ⚡ **NO DIODE ON LUGS.**  
If replacing with a coil of the same gauge and turn and it has a diode on it, remove it before using.

For Securing Hardware, see the Parts Table above, under the item desired.



# 4-Ball Trough Assembly, 500-6318-14-ND (Items 1-13) and Associated Parts: See Parts Table Below.

**Ordering Note: Identical to 500-6318-24 with exceptions, see note below Item 13 (Parts Table).**

Nr.	4-BALL TROUGH PARTS	QTY.	SPI PART Nr.	Nr.	4-BALL TROUGH PARTS	QTY.	SPI PART Nr.
1	Ball Trough Outhole Mounting Bracket	1	515-6580-01	11	Trough Ball Guide Plate	0	535-7801-00
<small>Item 1 is secured below the playfield by: #8 X 1/2" SHWH AB (Zc.) (Qty. 4) (234-5101-00)</small>							
2	Coil Mounting Bracket	1	535-7330-01	12	Dual OPTO TRANS Board Assembly	1	515-0173-00
<small>Item 2 is secured to Item 1 by: #8-32 X 3/8" HWH Swage (Sr.) Zinc (Qty. 4) (237-5975-00)</small>							
3	Coil Retaining Bracket	1	535-5203-03	13	Dual OPTO REC Board Assembly	1	515-0174-00
<small>Item 3 is secured to Item 2 by: #8-32 X 1/4" SHWH (Serr) Zinc (Qty. 2) (237-5975-04)</small>							
4	Coil, 26-1200 [ NO DIODE ]	1	090-5044-ND	<small>Items 12 &amp; 13 are secured by: #6-32 X 5/8" HWH Swg (Ser) Zc (Qty. 3/per) (237-5976-04)</small>			
<small>COIL DOES NOT REQUIRE A DIODE. SEE ☺ COIL NOTE BELOW FOR DETAILS.</small>							
5	Coil Sleeve (Short) (Formost #10-7077)	1	545-5076-01	<small>For Individual Items use : Dual OPTO Transmitter Board (Qty. 1) (520-5173-00), Dual OPTO Receiver Board (Qty. 1) (520-5174-00), OPTO PCB Tube Spacer (Brass) (Qty. 3/per) (530-5308-02) and OPTO PCB Rubber Grommet (Qty. 3/per) (545-5518-00)</small>			
6	Steel & Nylon Plunger Assembly	1	515-5941-01	<small>Ordering Note: If 500-6318-14-ND is unavailable, order the individual part(s) actually required. This assembly is identical to 500-6318-24-ND, -15 or -25 except for the quantity of Items 9 &amp; 10 (Qty. 4/per on 5-Ball Trough) and Item 11, required when a Magnet Mech. is used in the game (this game not required). -ND means no diode on Item 4, Coil, 26-1200.</small>			
7	Compression (Return) Spring	1	266-5020-00	<small>ASSOCIATED PARTS ARE NOT INCLUDED WITH THE ABOVE ASSEMBLY.</small>			
8	Rubber Bumper (Grommet)	1	545-5105-00	Nr.	ASSOCIATED PART(S)	QTY.	SPI PART Nr.
9	Micro Switch (Roller Actuator, Lite-Force)	3	180-5119-02	AP-A	Ball Trough Enter/Exit Scoop	1	535-7329-01
<small>Item 9 requires: Heat Shrink Tubing 1/8" ø PUI-24 (Qty. 1"/per) (605-5006-00)</small>							
<small>Switch has a Diode (1N4004) (112-5003-00). Can be replaced with (1N4001) (112-5001-00).</small>							
10	Switch Body Protect Plate	3	535-6539-00	AP-B	* Steel Balls (1-1/16" ø)	4	260-5000-00

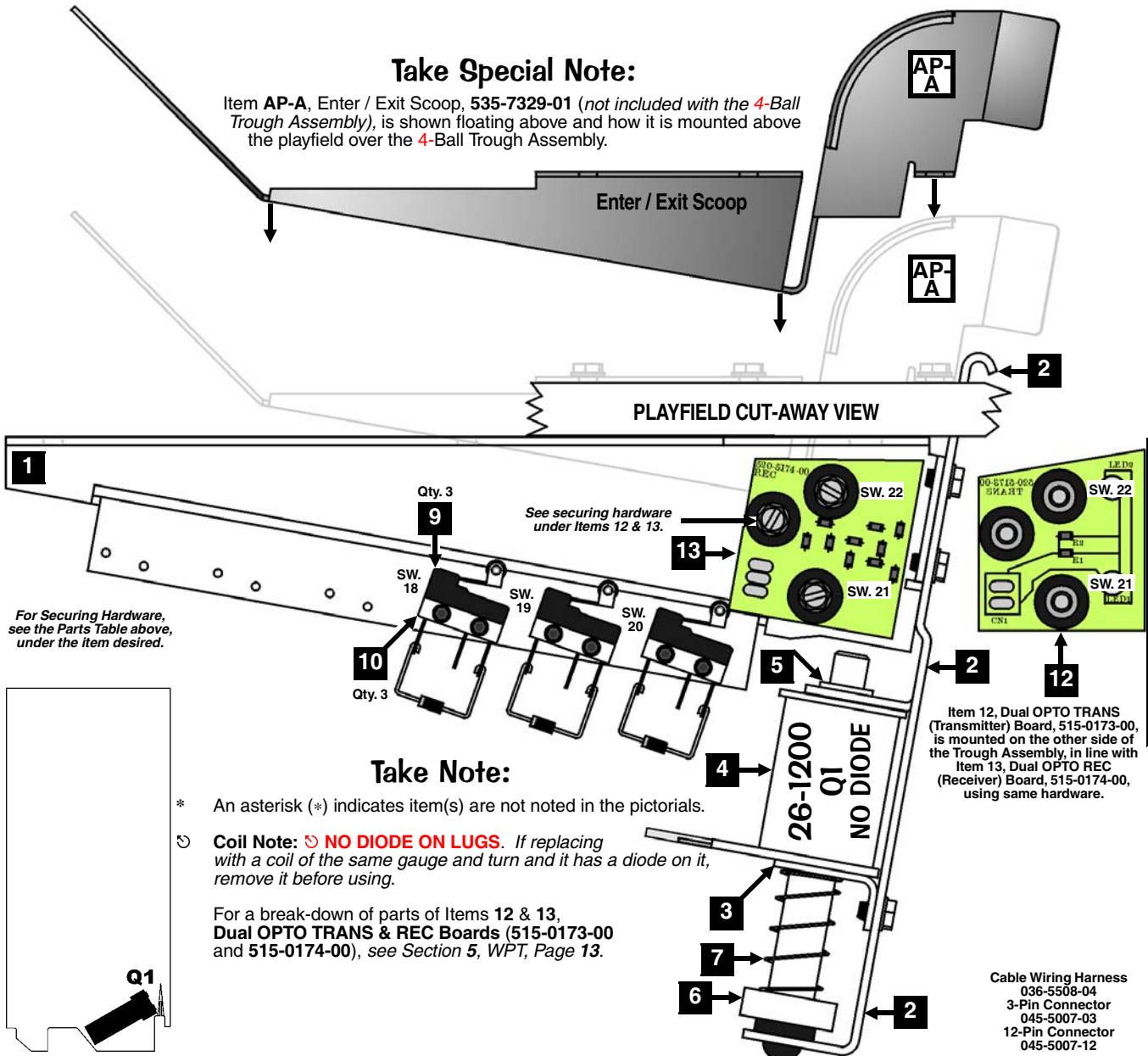

# Flipper (Left) Assembly, 500-6543-14-ND (Items 1-15) and Assoc. Parts: White Flipper Bat & Shaft Assy., 515-5133-08-06 (Items AP-A/-B)

Nr.	FLIPPER (LEFT) PARTS	QTY.	SPI PART Nr.	Nr.	FLIPPER (LEFT) PARTS	QTY.	SPI PART Nr.
1	Flipper Base Plate (LEFT)	1	<b>See FRP1</b>	13	Crank Bar	1	530-5070-02
Item 1 is secured below the playfield by: #10 X 1/2" HWH MS (Serr) Zinc ST (Qty. 8) (237-5949-00) <b>Ordering Note:</b> Use Item <b>FRP1</b> , see the end of this Parts Table.				Item 13 requires: Bushing, .192" ø ID X .312" ø OD X .195" (Qty. 1) (530-5139-00)			
2	Flipper Bat Bushing (White Plastic) .25" ø I.D.	1	545-5070-00	14®	Switch Actuator (LEFT) Sub-Assy.	1	515-7257-01
Item 2 is secured to Item 1 by: #6-32 X 3/8" HWH Swage (Ser.) Zc. (Qty. 3) (237-5976-02)				For Individual Items use : Actuator & Spring Bracket (LEFT) (535-9038-01) and ® Switch Actuator (White Plastic) (545-5612-00) and is secured to the Bracket by: Rivet, 1/8" ø X 1/4" Lg. (Qty. 1) (249-5003-00)			
3	Power (EOS / End-of-Stroke) Switch	1	180-5149-00	15	Set Screw: #10-32 X 3/4" Socket Hd.	2	237-6144-00
Item 3 is secured to Item 1 by: #6-32 X 5/8" HWH Swage (Ser.) Zc. (Qty. 2) (237-5976-04)				Item 15 requires: #10-32 Nylon Stop Nut (Qty. 1 Flipper Link Side Only) (240-5203-00) and #10 Split Lock Washer (244-5003-00) <b>Tool Required for Item 15:</b> 5/32" or 4mm Allen Wrench			
4	Sw. Plate/Spring Return Brkt. (LEFT)	1	535-7354-01	<b>Flipper Rebuild Parts for Easier Installation, Save \$:</b>			
5	Flipper Return Spring	1	265-5035-00	FRP1	Flipper Base Plate Kit (LEFT)		515-6617-01
6	Coil Stop Bracket Sub-Assembly	1	515-6308-01	Includes Item 1 pre-threaded, with the Securing Hardware for Items 2, 3, 6 & 8.			
Item 6 is secured to Item 1 by: #10-32 X 3/8" SHWH Swage (Serr) Zinc (Qty. 2) (237-5985-00) and #10 Split Lock Washer (Qty. 2) (244-5003-00)				FRP2	Plunger, Link & Crank (LEFT) Assy.		515-7203-01
7	Spring Washer (17/32" ID X 3/4" X 1")	1	269-5002-00	Includes above Items 12, 13, 14 and 15 and is pre-assembled.			
8	Coil Support Bracket	1	535-7356-00	FRP3	Flipper (LEFT) Rebuild Kit		500-6307-10
Item 8 is secured to Item 1 by: #8-32 X 3/8" HWH Swage (Ser.) Zc. (Qty. 2) (237-5975-00)				Same as FRP2, but also includes above Items 6 & 10.			
9	Coil, 23-1100 [ NO DIODE ] (Left)	1	090-5030-ND				
COIL DOES NOT REQUIRE A DIODE. SEE ☺ COIL NOTE BELOW FOR DETAILS.							
10	Coil Sleeve	1	545-5388-00				
11	Deflector Pad (Bumper)	1	545-5428-00				
12	Flipper Plunger & Link Sub-Assy.	1	515-6304-03				
For Individual Items use : Flipper Plunger (530-5349-01) and Plunger "Flipper" Link (545-5611-01) and is secured to the Plunger by: Bushing, .16" ø ID X .281" ø OD X .187" (Qty. 1) (530-5532-00) and Spiral Pin ø 5/32" X 3/4" Lg. (Qty. 1) (251-5015-02)							
ASSOCIATED PARTS ARE NOT INCLUDED WITH THE ABOVE ASSEMBLY.							
Nr.	ASSOCIATED PART(S)	QTY.	SPI PART Nr.				
AP-A	WHITE Flipper Bat (Plain) & Shaft (Non-Knurled End) Assembly	1	515-5133-08-06				
AP-B	Large Flipper BLACK Rubber Ring	1	545-5277-00				

Sec. 4: Drawings ...

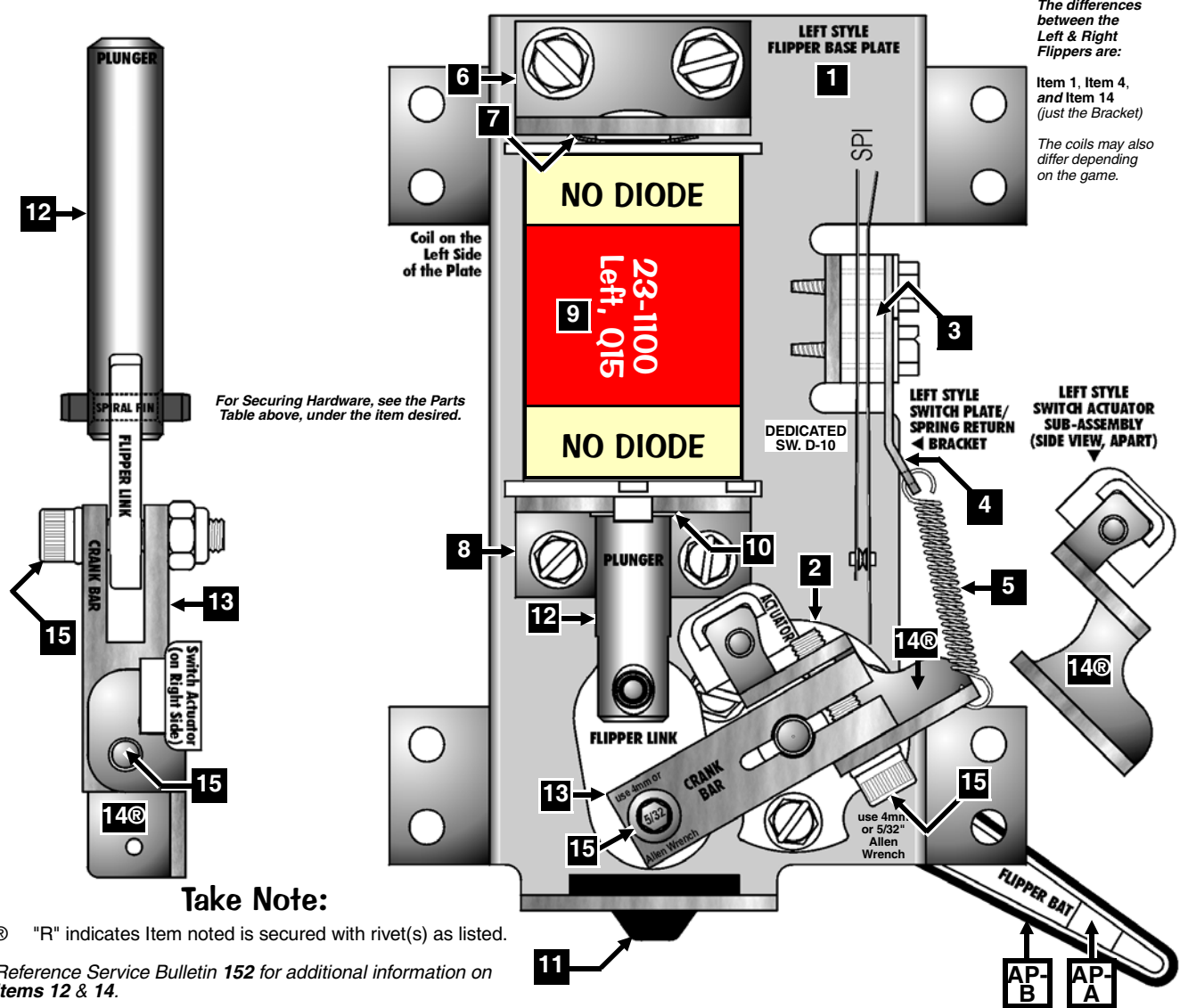

\* To Order the Flipper (Left) Rebuild Kit ask for Part Nr.: 500-6307-10 (includes items 6, 10, 12, 13, 14 & 15)

® "R" indicates Item noted is secured with rivet(s) as listed.  
Reference Service Bulletin 152 for additional information on Items 12 & 14.



# Flipper (Right) Assembly, 500-6543-04-ND (Items 1-15) and Assoc. Parts: White Flipper Bat & Shaft Assy., 515-5133-08-06 (Items AP-A/-B)

Nr.	FLIPPER (RIGHT) PARTS	QTY.	SPI PART Nr.	Nr.	FLIPPER (RIGHT) PARTS	QTY.	SPI PART Nr.
1	Flipper Base Plate (RIGHT) <small>Item 1 is secured below the playfield by: #10 X 1/2" HWH MS (Serr) Zinc ST (Qty. 8) (237-5949-00) <b>Ordering Note:</b> Use Item FRP1, see the end of this Parts Table.</small>	1	<b>See FRP1</b>	13	Crank Bar <small>Item 13 requires: Bushing, .192" ø ID X .312" ø OD X .195" (Qty. 1) (530-5139-00)</small>	1	530-5070-02
2	Flipper Bat Bushing (White Plastic) .25" ø I.D. <small>Item 2 is secured to Item 1 by: #6-32 X 3/8" HWH Swage (Ser.) Zc. (Qty. 3) (237-5976-02)</small>	1	545-5070-00	14®	Switch Actuator (RIGHT) Sub-Assy. <small>For Individual Items use : Actuator &amp; Spring Bracket (RIGHT) (535-9038-00) and ® Switch Actuator (White Plastic) (545-5612-00) and is secured to the Bracket by: Rivet, 1/8" ø X 1/4" Lg. (Qty. 1) (249-5003-00)</small>	1	515-7257-00
3	Power (EOS / End-of-Stroke) Switch <small>Item 3 is secured to Item 1 by: #6-32 X 5/8" HWH Swage (Ser.) Zc. (Qty. 2) (237-5976-04)</small>	1	180-5149-00	15	Set Screw: #10-32 X 3/4" Socket Hd. <small>Item 15 requires: #10-32 Nylon Stop Nut (Qty. 1 Flipper Link Side Only) (240-5203-00) and #10 Split Lock Washer (244-5003-00) <b>Tool Required for Item 15:</b> 5/32" or 4mm Allen Wrench</small>	2	237-6144-00
4	Sw. Plate/Spring Return Brkt. (RIGHT)	1	535-7354-00	<b>Flipper Rebuild Parts for Easier Installation, Save \$:</b>			
5	Flipper Return Spring	1	265-5035-00	FRP1	Flipper Base Plate Kit (RIGHT) <small>Includes Item 1 pre-threaded, with the Securing Hardware for Items 2, 3, 6 &amp; 8.</small>		515-6617-00
6*	Coil Stop Bracket Sub-Assembly <small>Item 6 is secured to Item 1 by: #10-32 X 3/8" SHWH Swage (Serr) Zinc (Qty. 2) (237-5985-00) and #10 Split Lock Washer (Qty. 2) (244-5003-00)</small>	1	515-6308-01	FRP2	Plunger, Link & Crank (RIGHT) Assy. <small>Includes above Items 12, 13, 14 and 15 and is pre-assembled.</small>		515-7203-00
7	Spring Washer (17/32" ID X 3/4" X 1")	1	269-5002-00	FRP3	Flipper (RIGHT) Rebuild Kit <small>Same as FRP2, but also includes above Items 6 &amp; 10.</small>		500-6307-00
8	Coil Support Bracket <small>Item 8 is secured to Item 1 by: #8-32 X 3/8" HWH Swage (Ser.) Zc. (Qty. 2) (237-5975-00)</small>	1	535-7356-00	<small>ASSOCIATED PARTS ARE NOT INCLUDED WITH THE ABOVE ASSEMBLY.</small>			
9	Coil, 22-1100 [ NO DIODE ] (Right) <small>COIL DOES NOT REQUIRE A DIODE. SEE ☺ COIL NOTE BELOW FOR DETAILS.</small>	1	090-5030-ND	Nr.	<b>ASSOCIATED PART(S)</b>	<b>QTY.</b>	<b>SPI PART Nr.</b>
10	Coil Sleeve	1	545-5388-00	AP-A	WHITE Flipper Bat (Plain) & Shaft (Non-Knurled End) Assembly	1	515-5133-08-06
11	Deflector Pad (Bumper)	1	545-5428-00	AP-B	Large Flipper BLACK Rubber Ring	1	545-5277-00
12	Flipper Plunger & Link Sub-Assy. <small>For Individual Items use : Flipper Plunger (530-5349-01) and Plunger Flipper Link (545-5611-01) and is secured to the Plunger by: Bushing, .16" ø ID X .281" ø OD X .187" (Qty. 1) (530-5532-00) and Spiral Pin ø 5/32" X 3/4" Lg. (Qty. 1) (251-5015-02)</small>	1	515-6304-03				

\* To Order the Flipper (Right) Rebuild Kit ask for Part Nr.: 500-6307-00 (includes Items 6, 10, 12, 13, 14 & 15)

The differences between the Left & Right Flippers are:

Item 1, Item 4, and Item 14 (just the Bracket)

The coils may also differ depending on the game.

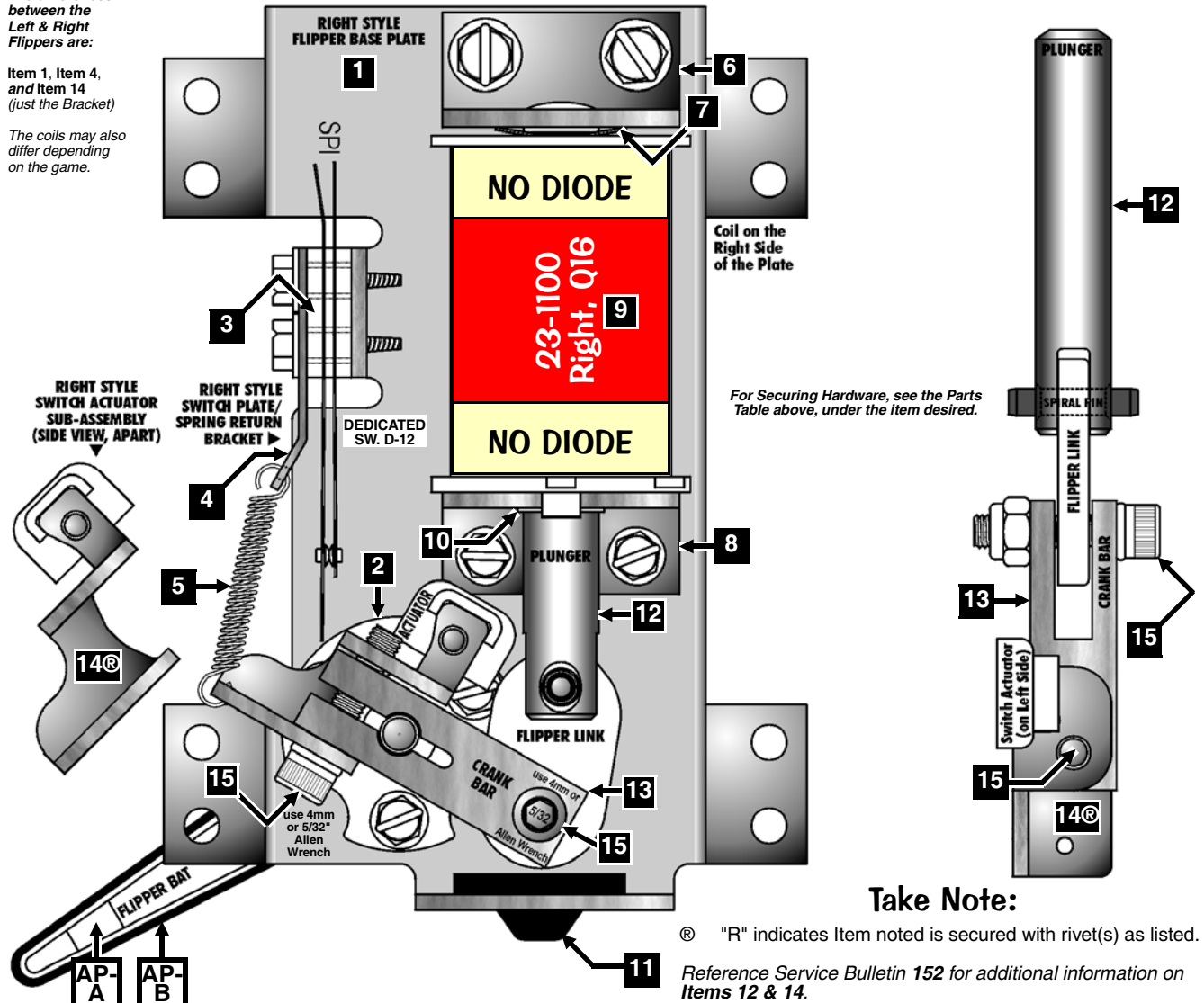

Sec. 4: Drawings ...

**Take Note:**

® "R" indicates Item noted is secured with rivet(s) as listed.

Reference Service Bulletin 152 for additional information on Items 12 & 14.



# Slingshot (Left & Right) Assemblies, 500-5849-00-ND (Qty. 2) (Items 1-9)

Nr.	SLINGSHOT PARTS	QTY.	SPI PART Nr.	Nr.	SLINGSHOT PARTS	QTY.	SPI PART Nr.
1	Slingshot Bracket Assembly Item 1 is secured below the playfield by: #8 X 1/2" SHWH AB (Zc.) (Qty. 3) (234-5101-00)	1/per	515-5339-01	6	Compression (Return) Spring	1/per	266-5020-00
2	Coil Retaining Bracket Item 2 is secured to Item 1 by: #8-32 X 3/8" PPH MS (Sems) (Qty. 2) (232-5301-00)	1/per	535-5203-03	7	Slingshot Stack (Blade) Switch Only 1 of the 2 Switches has a Diode (1N4004) (112-5003-00). See Note Below on Drawing. Can be replaced with (1N4001) (112-5001-00).	2/per	180-5054-00
3	Coil, 23-800 [ NO DIODE ] COIL DOES NOT REQUIRE A DIODE. SEE ☺ COIL NOTE BELOW FOR DETAILS.	1/per	090-5001-ND	8	Switch Body Protect Plate Items 7 & 8 are secured to Item 1 by: #6-32 X 5/8" HWH Swage (Qty. 4) (237-5976-04)	2/per	535-5045-00
4	Coil Sleeve	1/per	545-5031-00	9®	Riveted Arm & Tip Assembly For Individual Parts use (requires drilling out rivet & re-venting): Arm (515-5341-01), Kicker Tip (545-5216-01) and Rivet, 1/8" ø x 1/4" Lg. (249-5003-00) The Riv. Arm is secured to Item 1 by: Retaining Ring, 1/4" ø Shaft (Qty. 1) (270-5002-00) Ordering Note: If 515-5340-01 is unavailable, order the individual part(s) actually required.	1/per	515-5340-01
5	Plunger & Link Assembly For Individual Items use: Plunger 2" Lg. (530-5025-01), Plunger Link (545-5293-00) and Roll Pin 1/8" ø x 5/8" Lg. (251-5008-00) The Plunger Link is secured to the Riveted Arm by: Retaining Ring, 1/4" ø Shaft (Qty. 1) (270-5002-00) Ordering Note: If 515-5338-00 is unavailable, order the individual part(s) actually required.	1/per	515-5338-00		Ordering Note: If 500-5849-00-ND is unavailable, order the individual part(s) actually required. This assembly is identical to 500-5849-00 with the exception of Item 3, which uses a Coil, 23-800, with a Diode across the lugs (090-5001-00T) instead.		

## Take Note:

- ☺ **Coil Note:** ☹ **NO DIODE ON LUGS.** If replacing with a coil of the same gauge and turn and it has a diode on it, remove it before using.
- ® "R" indicates Item noted is secured with rivet(s) as listed.

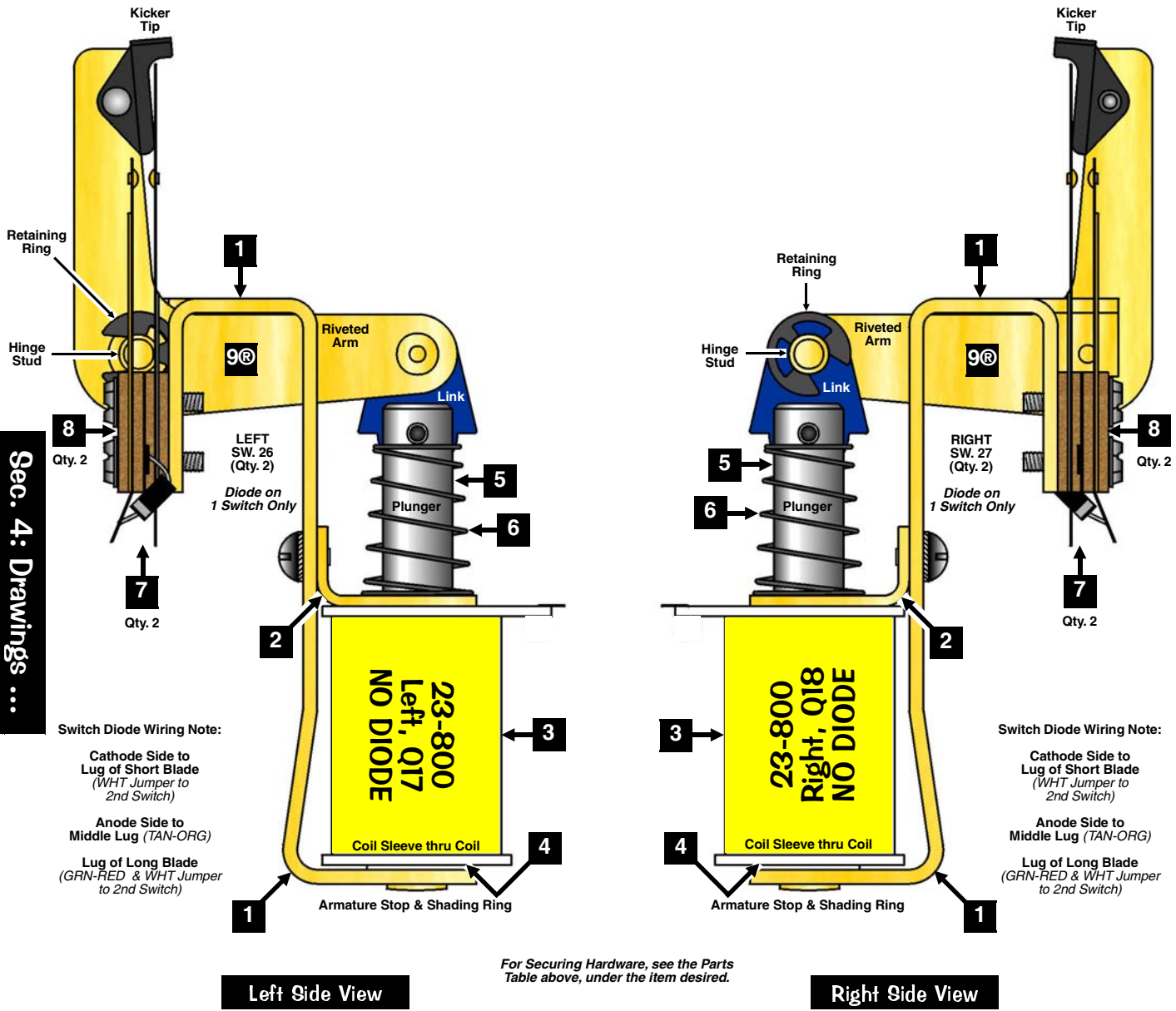

# Bumper Top, Bumper Bottom & Bumper Switch Individual Parts Only (Items 1-18) and Associated Part: See Parts Table Below.

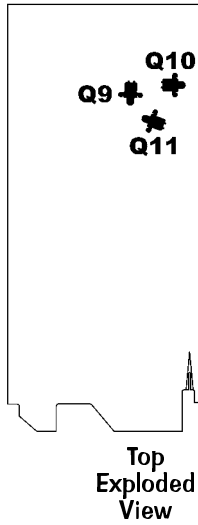

## Special Note:

**DOTS:** The Lamp Diode, 1N4001, is not located on the socket (nor included); it's located on a Terminal Strip under the playfield. See Section 5, Chapter 2, Playfield Terminal Strips., Page 102, for more details.

For Securing Hardware, see the Parts Table below, under the item desired.

## Ordering Note:

Individual parts can be ordered. However, if the entire Bumper is required, use the **ASM. REF.** Number(s) under each section in the Parts Table.

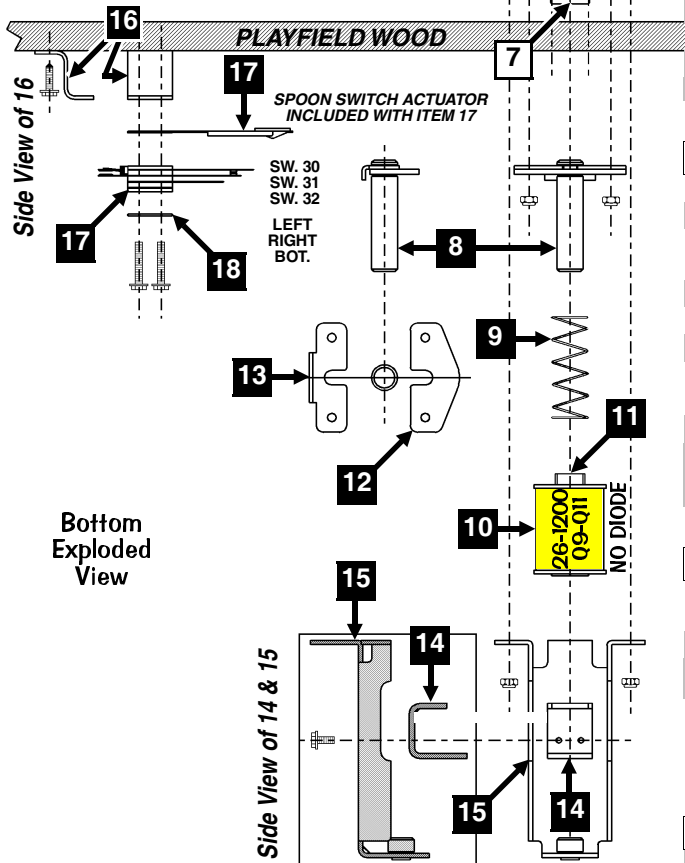

LAMPS  
27 (LEFT)  
27 (RIGHT)  
27 (BOT.)

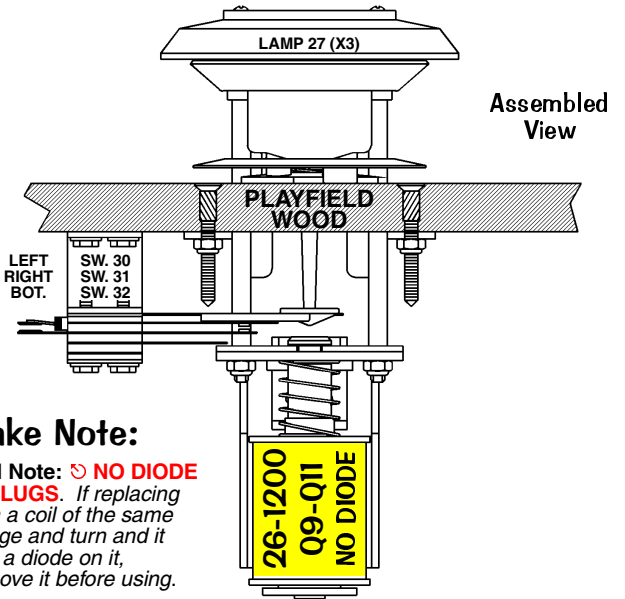

## Take Note:

Coil Note: **NO DIODE ON LUGS.** If replacing with a coil of the same gauge and turn and it has a diode on it, remove it before using.

Nr.	BUMPER TOP PARTS	QTY.	SPI PART Nr.
1	LED Module (WHT) (6.3v) Wedge Base	1/per	112-5024-08
2	Wedge Base Socket	1/per	077-5206-00
3	Bumper Body	1/per	545-5197-00
Item 3 is secured by: #5 X 7/8" PRH AB (Zinc) (Qty. 2/per) (237-5826-00)			
4	Ring Assembly	1/per	515-5085-00
Item 4 is secured by: #6-32 Nylon Stop Nut (Qty. 2/per) (240-5005-00)			
5	Bumper Skirt	1/per	545-5607-00
6	Bumper Skirt Compression Spring	1/per	266-5048-00
7	Bumper Base	1/per	545-5195-00
(ASM. REF. 515-6459-01L (Qty. 3), Items 1-7)			

Nr.	BUMPER BOTTOM PARTS	QTY.	SPI PART Nr.
8	Plunger	1/per	530-5348-00
9	Compression (Return) Spring	1/per	266-5047-00
10	Coil, 26-1200 [ NO DIODE ]	1/pe	090-5044-ND
COIL DOES NOT REQUIRE A DIODE. SEE COIL NOTE ABOVE FOR DETAILS.			
11	Coil Sleeve	1/per	545-5031-00
12	Fiber Yoke	1/per	545-5609-00
13	Metal Yoke	1/per	535-7346-00
14	Metal Yoke Stop	1/per	535-7347-00
Item 14 is secured by: #6-32 X 1/4" HWH Swage (Serr.) Zinc (Qty. 2/per) (237-5976-01)			
15	Coil Bracket Welded Assembly	1/per	515-5939-00
Item 15 is secured by: #6-32 X 1-3/16" Spiral Fin Shank (Qty. 3/per) (237-5957-00) and #6-32 Nylon Stop Nut (Qty. 3/per) (240-5005-00)			
(ASM. REF. 515-6459-04-ND (Qty. 3), Items 8-15)			

The Top & Bottom Assemblies are secured together by hardware included in assemblies.

Nr.	BUMPER SWITCH PARTS	QTY.	SPI PART Nr.
16	Switch Bracket	1/per	535-7342-00
Item 16 is secured by: #8 X 1/2" HWH AB (Zinc) (Qty. 2/per) (234-5101-00)			
17	Bumper Stack (Blade) Switch Assy.	1/per	180-5015-04
Included with Item 17: Spoon Switch Actuator (545-5610-02). Switch has a Diode (1N4004) (112-5003-00). Can be replaced with (1N4001) (112-5001-00).			
18	Switch Body Protect Plate	1/per	535-7344-00
Items 17 & 18 are secured by: #6-32 X 3/4" HWH Swage (Serr.) Zc. (Qty. 2) (237-5976-05)			
(ASM. REF. 515-6459-09 (Qty. 3), Items 16-18)			

ASSOCIATED PARTS ARE NOT INCLUDED WITH THE ABOVE ASSEMBLIES.

Nr.	ASSOCIATED PART(S)	QTY.	SPI PART Nr.
AP-A	Bumper [Pop] Cap (Red)	3	550-5057-02
Item AP-A is secured by: #4 X 3/4" PRH (Zinc) T-25 (Qty. 2/per) (237-5873-00)			

# VUK (at top edge of playfield) Assembly, 500-6867-01 (Items 1-11)

Ball is delivered up on the Right Plastic Ramp via the VUK Tube Wire Ramp.

Nr.	VUK PARTS	QTY.	SPI PART Nr.
1	Vertical Up-Kicker (VUK) Bracket, R.H. Style	1	535-9590-01
Item 1 is secured below the playfield by: #8 X 1/2" SHWHAB (Zc.) (Qty. 5) (234-5101-00)			
2	Switch (Circular) Actuator	1	545-6129-00
3	Compression (Actuator) Spring	1	266-5083-00
4	Coil Retaining Bracket	1	535-5203-03
Item 4 is secured to Item 1 by: #8-32 X 1/4" PPH (Serr) Zinc (Qty. 2) (232-5300-00)			
5	Coil, 26-1200 [ NO DIODE ]	1	090-5044-ND
COIL DOES NOT REQUIRE A DIODE. SEE ☉ COIL NOTE BELOW FOR DETAILS.			
6	Coil Sleeve (Short) (Formost #10-7077)	1	545-5076-01
7	Steel & Nylon Plunger Assembly	1	515-5941-01
8	Compression (Return) Spring	1	266-5020-00
9	Rubber Bumper (Grommet)	1	545-5105-00
10	Micro Switch (Sim. Roller)	1	180-5209-00
Switch has a Diode (1N4004) (112-5003-00). Can be replaced with (1N4001) (112-5001-00).			
11	Switch Body Protect Plate	1	535-6539-00
Item 11 secures Item 10 to 1 by: #2-56 X 1/2" HWH (Ser) #4HD (Qty. 2) (237-5937-02)			

Ordering Note: If 500-6867-01 is unavailable, order the individual part(s) actually required.

For Securing Hardware, see the Parts Table above, under the item desired.

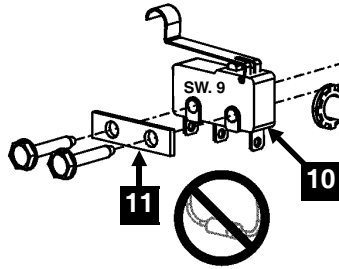

### Special Note:

**DOTS:** The Switch Diode, 1N4001, is not located on this Assembly (nor included); it's located on a Terminal Strip under the playfield. See Section 5, Chapter 2, Playfield Terminal Strips..., Page 102, for more details.

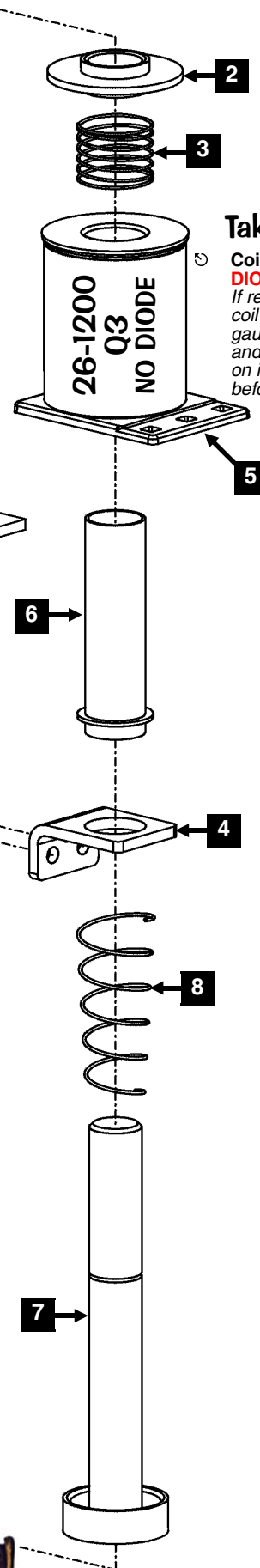
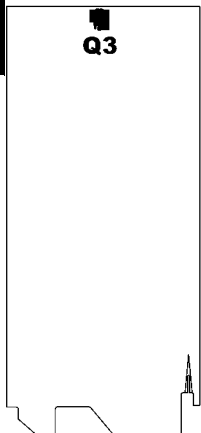

### Take Note:

**Coil Note:** ☉ **NO DIODE ON LUGS.**  
If replacing with a coil of the same gauge and turn and it has a diode on it, remove it before using.





# Ball Deflector (Ship Pin Lane Lock/Up Post) Assembly, 500-6657-00-ND (Items 1-7)

Ball can be stopped (locked) in the Ship Lane past the gate.

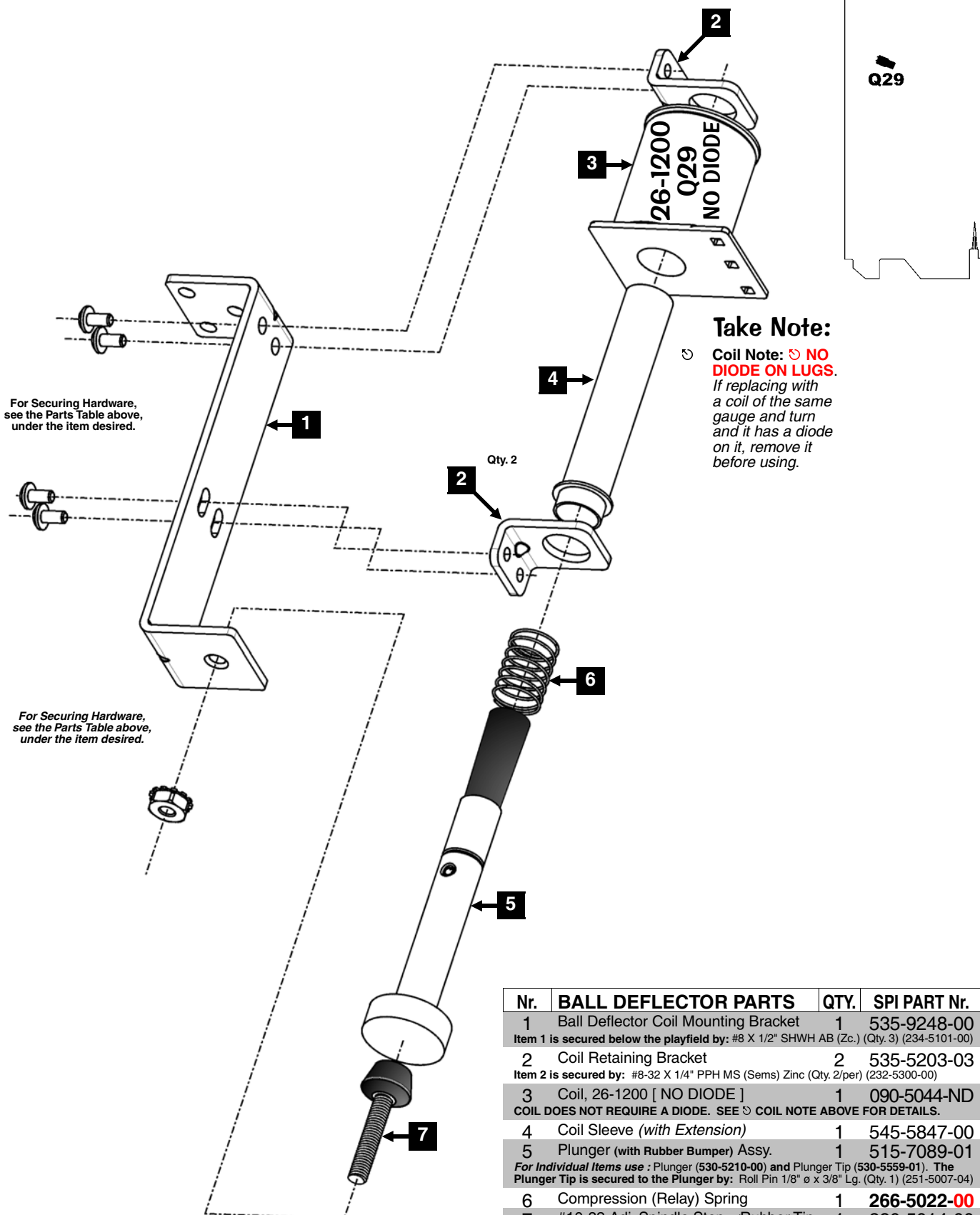

Nr.	BALL DEFLECTOR PARTS	QTY.	SPI PART Nr.
1	Ball Deflector Coil Mounting Bracket	1	535-9248-00
Item 1 is secured below the playfield by: #8 X 1/2" SHWH AB (Zc.) (Qty. 3) (234-5101-00)			
2	Coil Retaining Bracket	2	535-5203-03
Item 2 is secured by: #8-32 X 1/4" PPH MS (Sems) Zinc (Qty. 2/per) (232-5300-00)			
3	Coil, 26-1200 [ NO DIODE ]	1	090-5044-ND
COIL DOES NOT REQUIRE A DIODE. SEE COIL NOTE ABOVE FOR DETAILS.			
4	Coil Sleeve (with Extension)	1	545-5847-00
5	Plunger (with Rubber Bumper) Assy.	1	515-7089-01
For Individual Items use : Plunger (530-5210-00) and Plunger Tip (530-5559-01). The Plunger Tip is secured to the Plunger by: Roll Pin 1/8" ø x 3/8" Lg. (Qty. 1) (251-5007-04)			
6	Compression (Relay) Spring	1	266-5022-00
7	#10-32 Adj. Spindle Stop w/Rubber Tip	1	280-5014-00
Item 7 is secured by: #10-32 Keps Nut (Qty. 1) (240-5208-00)			

Ordering Note: If 500-6657-00-ND is unavailable, order the individual part(s) actually required.

Sec. 4: Drawings ...



# Up/Down Post (Treasure Chest Ball Lock) Assembly, 500-5867-12-ND (Items 1-8)

Ball can be stopped (locked) under ('in') the Treasure Chest awaiting Display Effects.

Nr.	UP/DOWN POST PARTS	QTY.	SPI PART Nr.	Nr.	UP/DOWN POST PARTS	QTY.	SPI PART Nr.
1	Ball Lock Mounting Bracket Assembly	1	515-7132-00	4	Coil Sleeve	1	545-5411-00
Item 1 is secured below the P/F by: #8 X 1/2" SHWH AB (Zinc) (Qty. 3) (234-5101-00)				5	Plunger, 3.81" Lg. (w/ Nylon Tip) Asm.	1	515-6119-02
2	Coil Retaining Bracket	2	535-5203-03	6	Compression (Relay) Spring	1	266-5020-00
Item 2 is sec. to Item 1 by: #8-32 X 1/4" PPH MS (Sems) Zinc (Qty. 2) (232-5300-00)				7	Nyliner 7/16" Shaft (7L2-FF)	1	545-5418-01
3	Coil, 26-1200 [ NO DIODE ]	1	090-5044-ND	8	Retaining Ring, 7/16" ø Shaft	1	270-5005-00
COIL DOES NOT REQUIRE A DIODE. SEE ☺ COIL NOTE ABOVE FOR DETAILS.				<i>Ordering Note: If 500-5867-12-ND is unavailable, order the individual part(s) actually required.</i>			

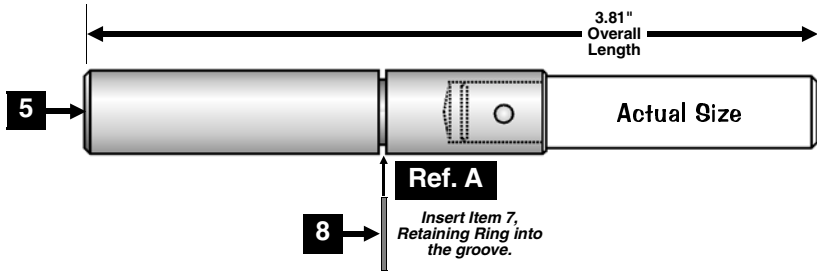

For Securing Hardware, see the Parts Table above, under the item desired.

Sec. 4: Drawings ...

**Take Note:**

☺ **Coil Note:** ☹ **NO DIODE ON LUGS.**  
If replacing with a coil of the same gauge and turn and it has a diode on it, remove it before using.

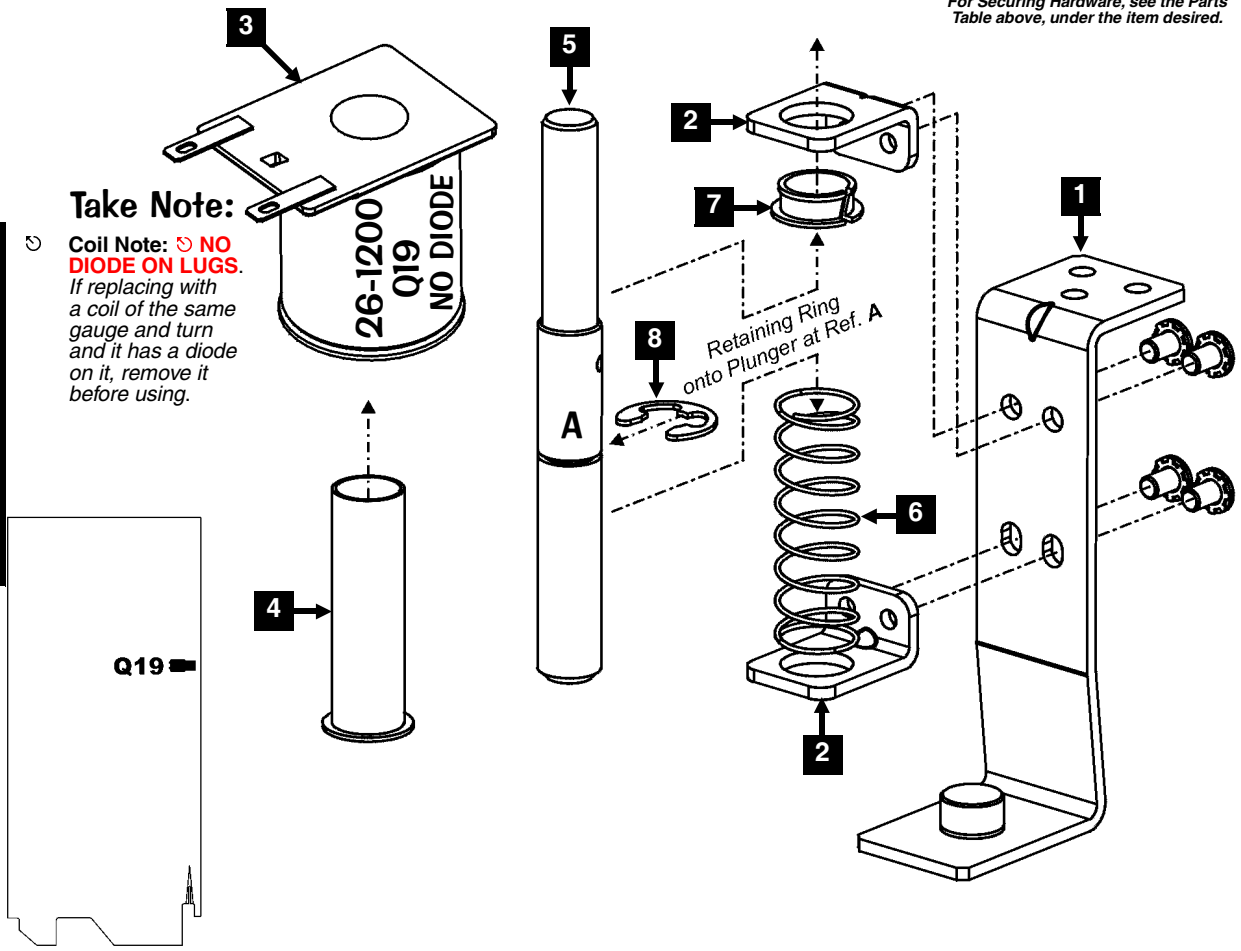

**Bumper Eject (30°) Assembly, 500-6511-01-ND (Items 1-8)  
and Associated Parts: See Parts Table Below  
Ball is stopped in the Eject Hole and kicked out into the three Bumpers.**

Nr.	30° EJECT PARTS	QTY.	SPI PART Nr.	Nr.	30° EJECT PARTS	QTY.	SPI PART Nr.
1	Mounting Bracket 30° Eject (Left) <i>Item 1 is secured below the P/F by: #8 X 1/2" SHWH AB (Zinc) (Qty. 2) (234-5101-00)</i>	1	535-8932-02	8	Rubber Bumper (Grommet) <i>Ordering Note: If 500-6511-01-ND is unavailable, order the individual part(s) actually required.</i>	1	545-5105-00
2	Coil Retaining Bracket <i>Item 2 is secured to Item 1 by: #8-32 X 1/4" PPH MS (Sems) (Qty. 2) (232-5300-00)</i>	1	535-5203-03	ASSOCIATED PART IS NOT INCLUDED WITH THE ABOVE ASSEMBLY.			
3	Coil, 26-1200 [ NO DIODE ] <b>COIL DOES NOT REQUIRE A DIODE. SEE ☺ COIL NOTE BELOW FOR DETAILS.</b>	1	090-5044-ND	Nr.	ASSOCIATED PART(S)	QTY.	SPI PART Nr.
4	Coil Sleeve (Short) (Formost #10-7077)	1	545-5076-01	AP-A	Switch (Eject) Assembly	1	500-6520-01
5	Spring Washer (17/32" ID X 3/4" X 1")	1	269-5002-00	<i>For Individual Items use : Switch Bracket (535-6173-00), Micro Switch (180-5186-01), Switch Body Protect Plate (535-6539-00), Diode 1N4004 (112-5003-00), #2-56 X 1/2" Unslt Serr HWH #4 Hd TR3 Black (Qty. 2) and (237-5937-02) #2-56 Hex Nut (Qty. 2) (240-5301-00)</i>			
6	Plunger (with Nylon Tip) Assembly	1	515-7197-00	<i>Bracket secured to P/F by: #8 X 1/2" SLT HWH AB (Zinc) (Qty. 2) (234-5101-00)</i>			
7	Compression (Return) Spring	1	266-5022-00				

**Take Note:**

☺ **Coil Note:** ☹ **NO DIODE ON LUGS.**  
If replacing with a coil of the same gauge and turn and it has a diode on it, remove it before using.

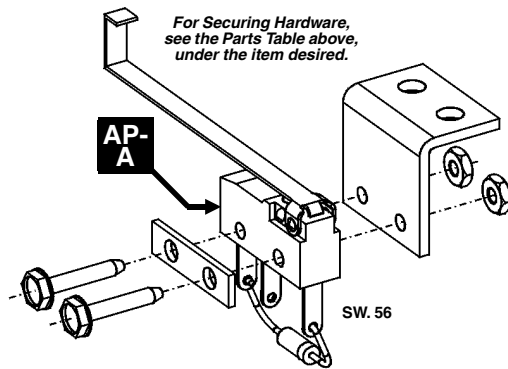
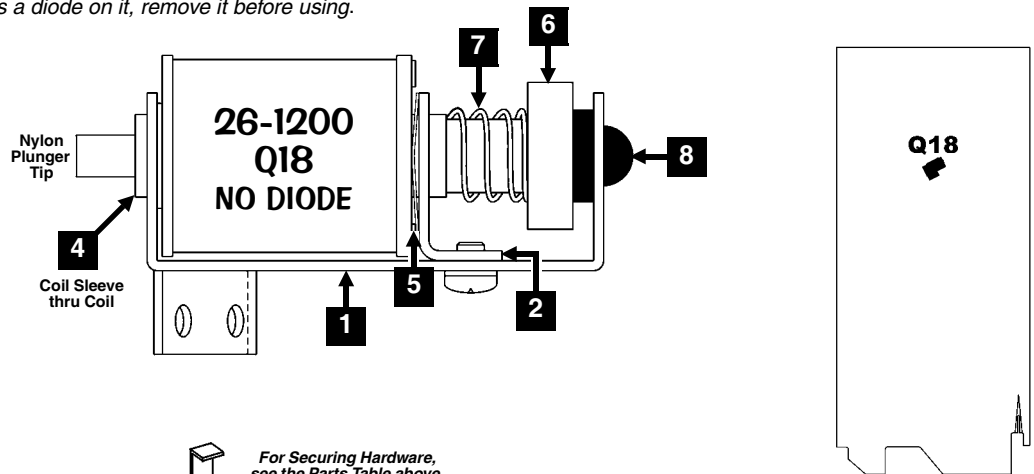

**Sec. 4: Drawings ...**



# Treasure Chest Assembly, Individual Parts Only (Items 1-34 + A-J)

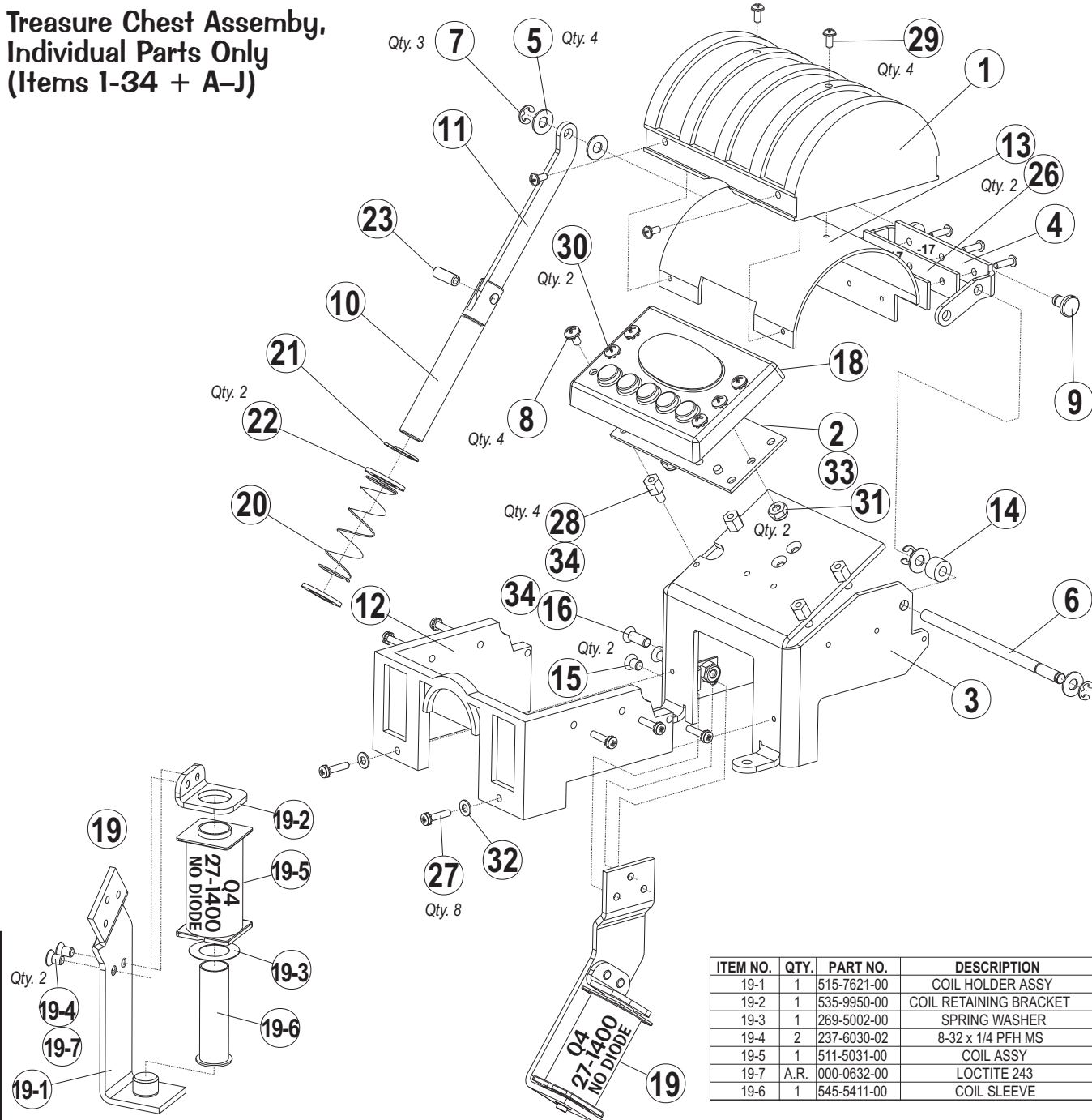

ITEM NO.	QTY.	PART NO.	DESCRIPTION
19-1	1	515-7621-00	COIL HOLDER ASSY
19-2	1	535-9950-00	COIL RETAINING BRACKET
19-3	1	269-5002-00	SPRING WASHER
19-4	2	237-6030-02	8-32 x 1/4 PPH MS
19-5	1	511-5031-00	COIL ASSY
19-7	A.R.	000-0632-00	LOCTITE 243
19-6	1	545-5411-00	COIL SLEEVE

Ref. Only 500-7003-00 (Items 1-34)

ITEM NO.	QTY.	PART NO.	DESCRIPTION
1	1	545-6263-00	MOLD, T.C. LID
2	1	520-5258-00	PCB, HEART LIGHT
3	1	535-9816-00	FRAME TREASURE CHEST
4	1	535-9818-00	PIVOT BRACKET
5	4	242-5088-00	NYLON WASHER .195" X .437" X .031"
6	1	251-5025-00	PIVOT PIN
7	3	270-5001-00	RETAINING E-RING, 3/16" SHAFT OD
8	4	232-5200-00	#6-32 X 1/4" PPH SEMS SCREW
9	1	530-5720-00	PIVOT PIN
10	1	530-5754-00	PLUNGER
11	1	535-9874-00	LINK
12	1	545-6264-00	MOLD, T.C. BODY
13	1	535-9877-00	CHEST LID FRAME
14	1	254-5000-02	SPACER - 3/8 OD X 1/4"
15	2	237-6030-02	8-32 x 1/4 PPH MS
16	1	237-6023-00	8-32 x 1/2 PPH MS
17	3	237-5979-00	SCREW, 4-40 X 3/8", PPH TF (ZINC)
18	1	545-6190-00	HEART LIGHT PIPE
19	1	511-5021-00	TREASURE CHEST COIL ASSY

Items 20-34 on the next page.

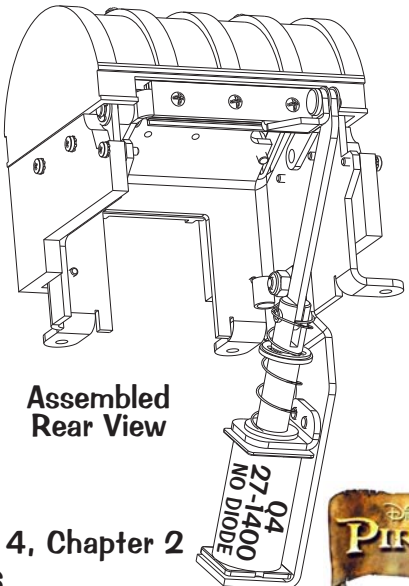

Assembled  
Rear View

Sec. 4: Drawings ...



# Treasure Chest Assembly, Individual Parts Only (Items 1-34 + A-J) Continued

Ref. Only 510-5033-00 (Items A-J)

ITEM NO.	PART NUMBER	DESCRIPTION	QTY.
A	803-5000-92	T/C FRONT PLASTIC 830-6055-10 INCL. IN SET	1
B	803-5000-92	T/C LOCK CVR PLASTIC 830-6055-15 INCL. IN SET	1
C	249-5001-00	RIVET - 1/8 X 3/16	2
D	246-5000-00	LOCKWASHER - #6	2
E	500-6775-00	OPTO TRANSCEIVER ASSEMBLY	2
F	237-5880-00	6-32 x 3/8 PHILLIPS PAN HEAD TF ZINC	4
G	550-5034-01	SMALL JEWEL POST - PLASTIC	1
H	237-5510-00	# 6-32 X 1-1/2" PPH SCREW	1
I	240-5005-00	# 6-32 NYLOK STOP NUT	1
J	545-5348-02	5/16 ID RUBBER RING	1

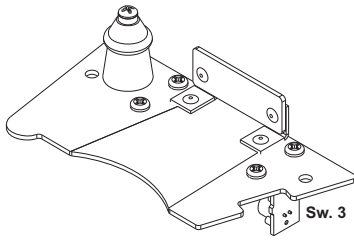

**A-J**  
Exploded View

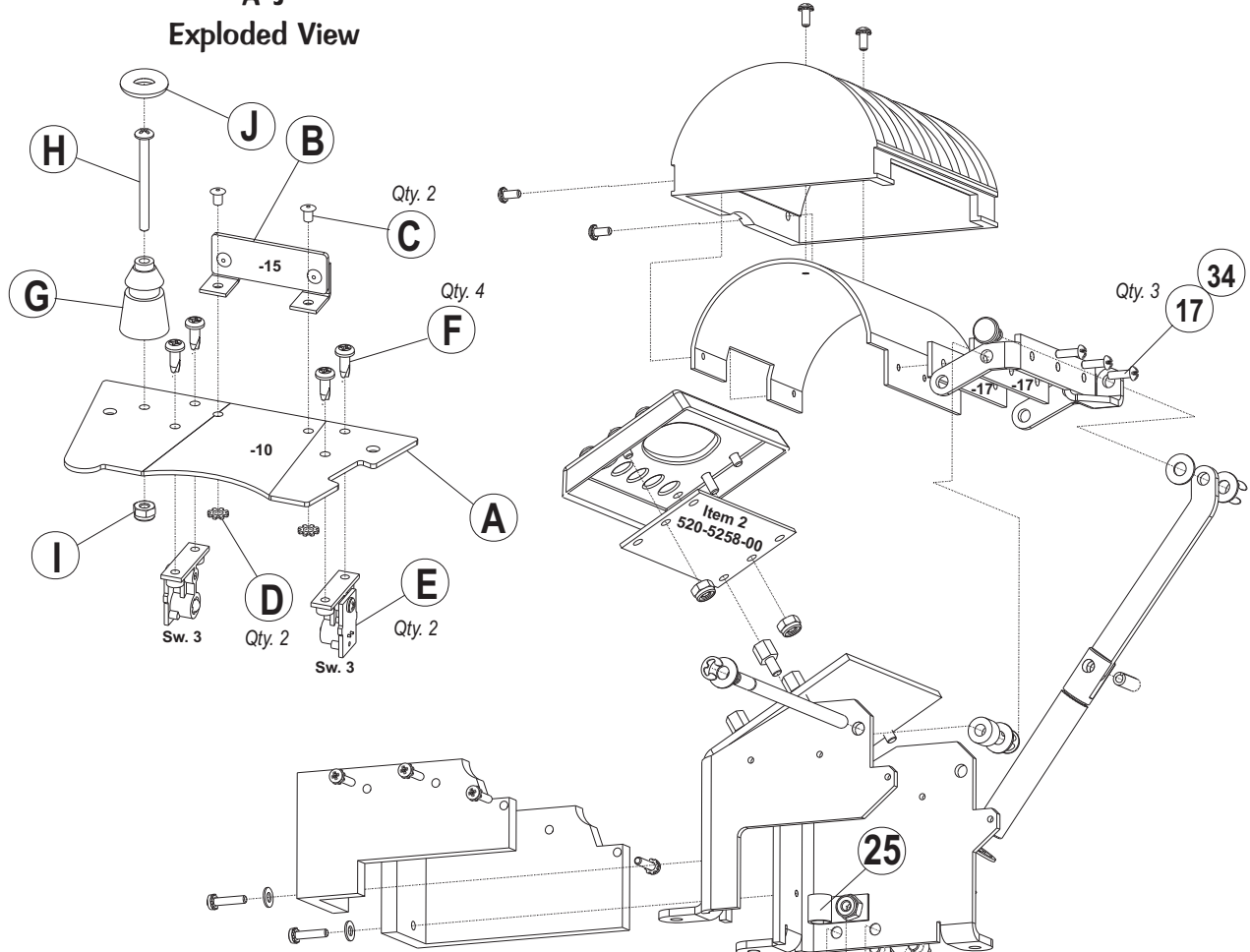

Items 1-19 on the previous page.

ITEM NO.	QTY.	PART NO.	DESCRIPTION
20	1	266-5047-00	COMPRESSION SPRING, POP BUMPER COIL
21	1	270-5005-00	RETAINING E-RING, 7/16" SHAFT OD
22	2	242-5081-00	WASHER - NYLON .75 OD x .44 ID
23	1	251-5022-00	.188 X 3/8" 420 SS SPRING PIN
24	1	240-5102-00	# 8-32 NYLON LOCK NUT
25	1	040-5000-03	1/4" CABLE CLAMP
26	1	803-5000-92	PLASTIC SHIM SPACER 830-6055-17 (x2) INCL. IN SET
27	8	237-5813-00	SCREW, #4-40 X 1/2" PPH SEMS
28	4	254-5052-00	HEX SPACER M/F 6-32 X .250 SS
29	4	237-5909-00	#4-40 X 1/4" PPH SEMS SCREW
30	2	232-5201-00	SCREW, #6-32 X 3/8" PPH MS SEMS
31	2	240-5005-00	# 6-32 NYLOK STOP NUT
32	A.R.	242-5017-00	WASHER
33	A.R.	626-5073-00	KAPTONE TAPE
34	A.R.	000-0632-00	LOCTITE 243

Ref. Only 500-7003-00 (Items 1-34)

**Assembled Front View**

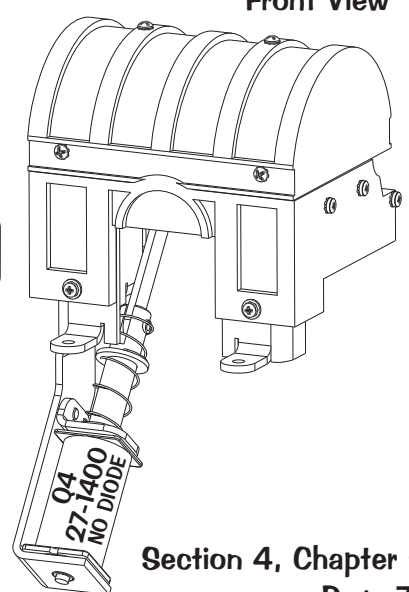

Sec. 4: Drawings ...



# Kraken Plastic Assembly **included in** Plastic Kit, 803-5000-92, (assembled as shown)

Ref. Only 510-5022-00 (K1-K4)

K3 ARM MUST CROSS BEHIND K2 ARM AS SHOWN

(-K5 was cut from -K3; now riveted to -K2)

Cannot Order Separately except for Socket, Bulb, Brackets and securing hardware.

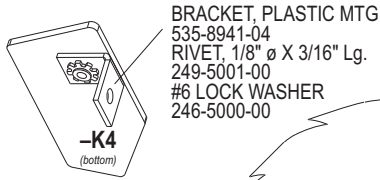
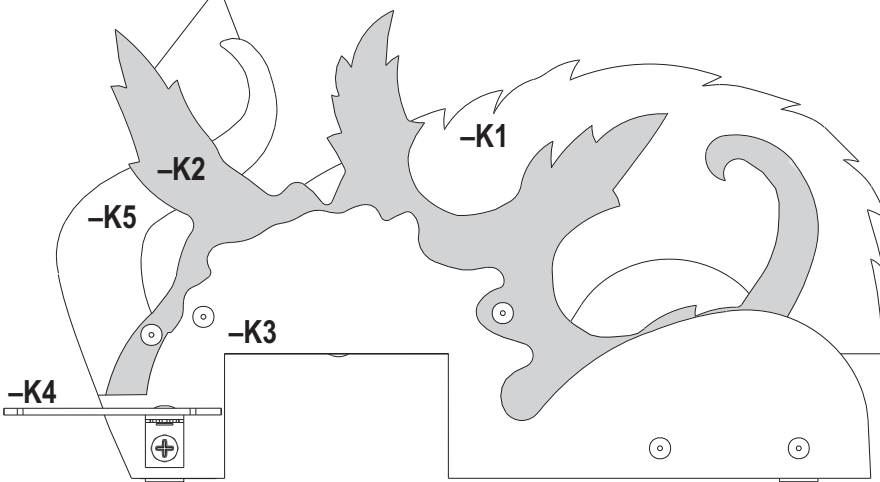

BRACKET, PLASTIC MTG  
535-8941-04  
RIVET, 1/8" ø X 3/16" Lg.  
249-5001-00  
#6 LOCK WASHER  
246-5000-00

Assembled Rear View of -K1 & -K2

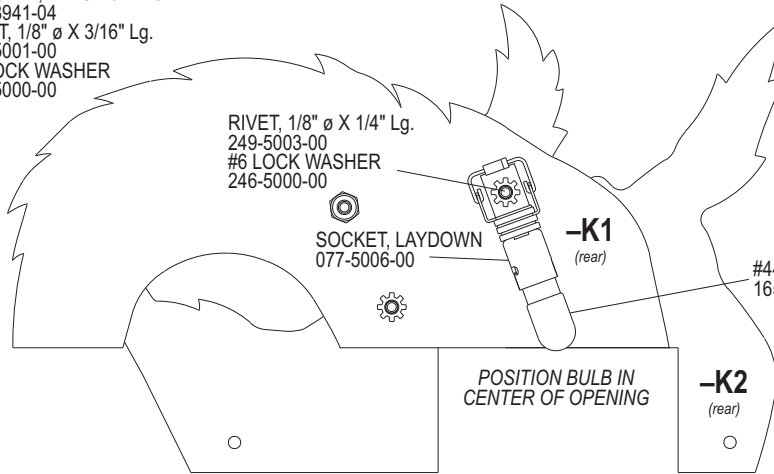

RIVET, 1/8" ø X 1/4" Lg.  
249-5003-00  
#6 LOCK WASHER  
246-5000-00

SOCKET, LAYDOWN  
077-5006-00

#44 BULB, RED  
165-5053-02

POSITION BULB IN CENTER OF OPENING

-K2 (rear)

BRACKET, PLASTIC MTG 80° BEND  
535-8941-07  
RIVET, 1/8" ø X 3/16" Lg.  
249-5001-00  
#6 LOCK WASHER  
246-5000-00

-K3 (rear) 80°

Sec. 4: Drawings ...

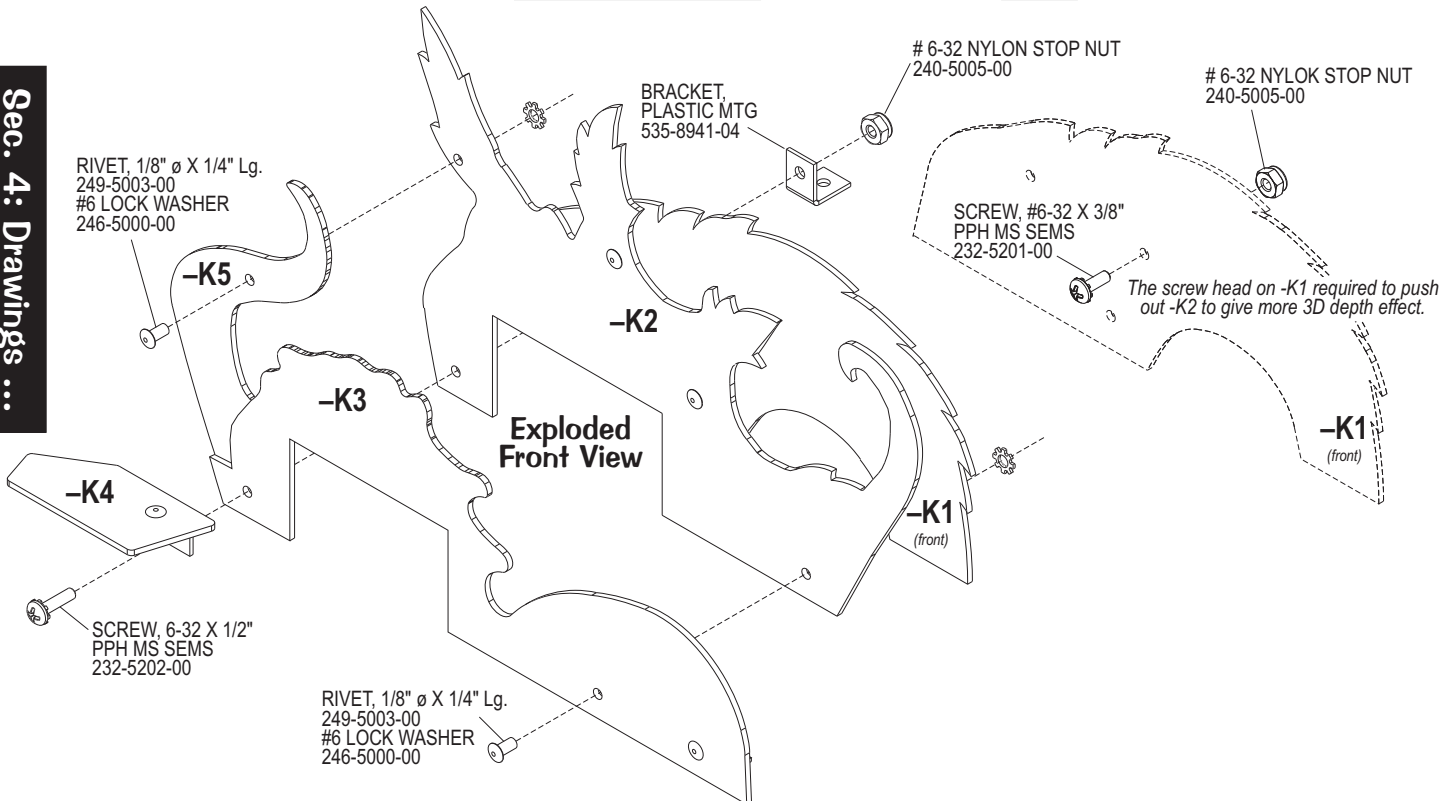

RIVET, 1/8" ø X 1/4" Lg.  
249-5003-00  
#6 LOCK WASHER  
246-5000-00

BRACKET, PLASTIC MTG  
535-8941-04

# 6-32 NYLON STOP NUT  
240-5005-00

# 6-32 NYLON STOP NUT  
240-5005-00

SCREW, #6-32 X 3/8" PPH MS SEMS  
232-5201-00

The screw head on -K1 required to push out -K2 to give more 3D depth effect.

SCREW, 6-32 X 1/2" PPH MS SEMS  
232-5202-00

RIVET, 1/8" ø X 1/4" Lg.  
249-5003-00  
#6 LOCK WASHER  
246-5000-00



# Pirate Ship Mechanical Assembly, Individual Parts Only (Items 1-9)

(The parts for the individual assemblies are detail on the following pages 80-83)

ITEM #	QTY	PART #	DESCRIPTION
1 Pgs. 80-81	1	500-6992-00	MOTOR & FRAME ASSEMBLY
2 Pgs. 82-83	1	500-6991-00	SHIP HULL ASSEMBLY
3	1	270-5002-00	RETAINING RING - 1/4"
4	4	237-6172-00	SCREW, 6-32 x 5/8 PPH ZINC
5	1	545-6179-00	SHIP HULL, MOLDED
6	1	545-6180-00	SAIL NO. 1 - BOW, MOLDED
7	1	545-6181-00	SAIL NO. 2 - STERN, MOLDED
8	1	254-5048-00	SPACER, 25/64 ID X 1/2 OD X .35 LG.
9	7	237-6182-00	SCREW, 6-32 X 1/4 PPH MS - BLACK
NOT SHN	A/R	000-0632-00	LOCTITE 243 THREADLOCKER

**Pirate Ship  
Removal / Disassembly  
Procedure  
on Page 83.**

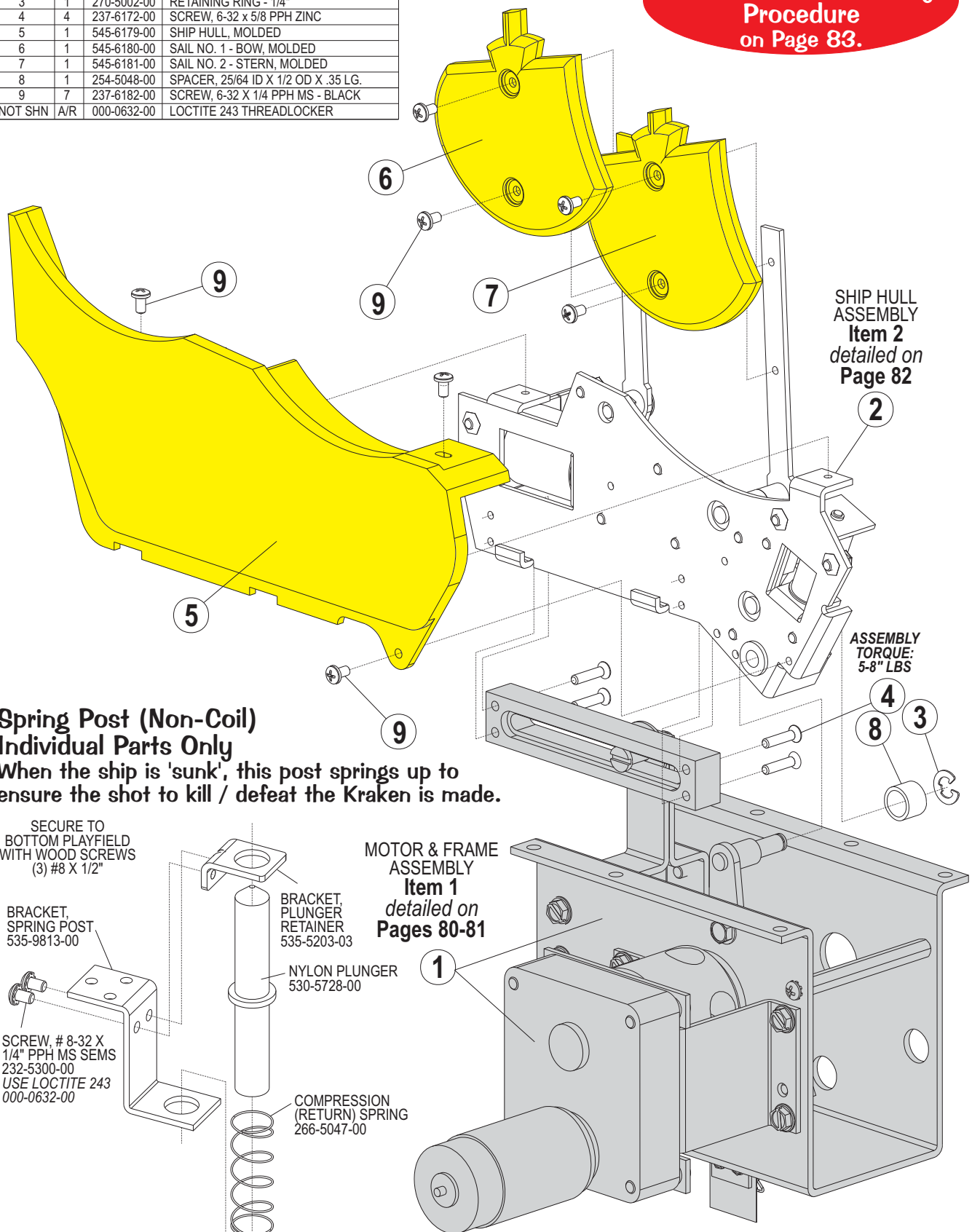

**Sec. 4: Drawings ...**



# Motor & Frame Assembly, Individual Parts Only (Items 1-22) (Operates the Pirate Ship shown assembled on the previous page.)

Views continued on the next page.

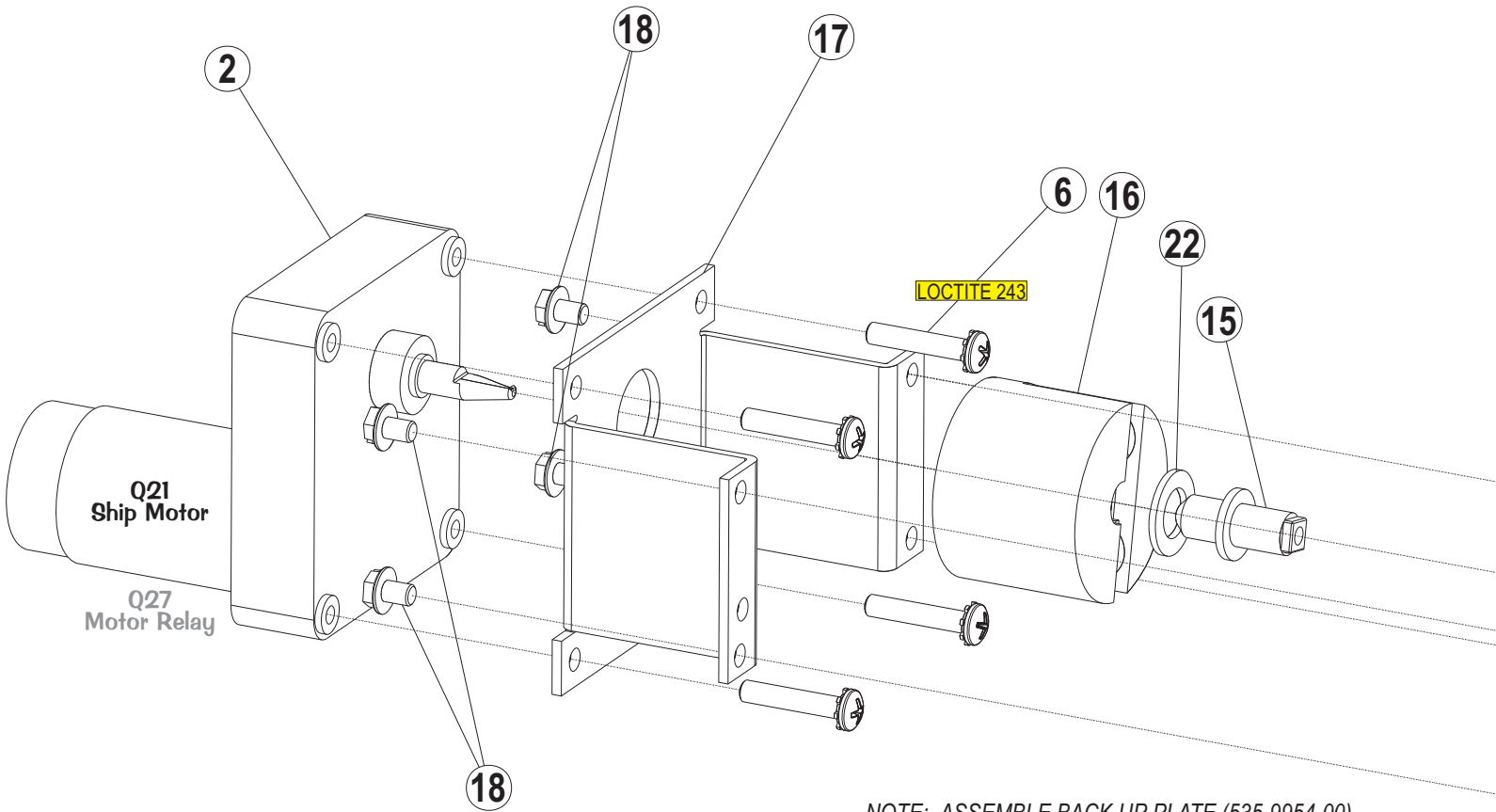

NOTE: ASSEMBLE BACK UP PLATE (535-9954-00)  
IN ORIENTATION SHOWN (FIRM CLUTCH).

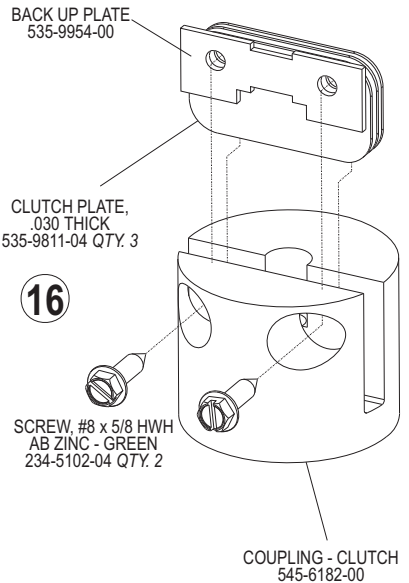

Sec. 4: Drawings ...

ITEM #	QTY	PART #	DESCRIPTION
1	1	535-9805-00	MAIN BRACKET
2	1	041-5101-00	GEAR MOTOR - 24VDC - 12 RPM
3	1	515-7571-00	MOTOR LINKAGE
4	1	232-5402-00	10-32 X 1/2" PPH MS SEMS SCREW
5	1	242-5038-00	WASHER 13/64 ID X 5/8 OD X 1/16
6	4	232-5406-00	10-32 X 1" PPH MS SEMS SCREW
7	1	REF 500-6987-00	UP SWITCH ASSEMBLY - PIRATES SHIP
8	1	REF 500-6990-00	FIXED PIN ASSEMBLY
9	1	REF 500-6988-00	DOWN SWITCH ASSEMBLY - PIRATES SHIP
10	2	232-5301-00	#8-32 X 3/8" PPH MS SEMS SCREW
11	4	237-5985-00	10-32 X 3/8 SHWH SWAGE SCREW
12	2	237-5976-01	# 6-32 X 1/4" HWH SCREW SWAGE
13	1	254-5008-16	HEX SPACER - 2 1/2 "
14	2	232-5202-00	SCREW, 6-32 X 1/2" PPH MS SEMS
15	1	530-5729-00	DRIVESHAFT
16	1	500-7011-00	CLUTCH ASSEMBLY
17	1	535-9812-00	INTERFACE BRACKET
18	4	237-6178-04	10-32 X 1/4 SHWH SWAGE SCREW
19	1	545-6189-00	BEARING
20	4	237-5902-00	8-32 x 3/8 PFH MS
21	1	237-5995-00	#10-32 x 1/2 HWH NO SLOT SERR ZI
22	1	242-5081-00	WASHER - NYLON .75 OD x .44 ID
NOT SHN	A/R	000-0632-00	LOCTITE 243 THREADLOCKER

Views of this assembly continued on the next page.





# Motor & Frame Assembly, Individual Parts Only (Items 1-22) Continued

Parts Table and more views on the previous page.

**NOTE:** THRUST WASHER (242-5095-00) MUST SPIN FREELY ONTO THE FIXED PIN (530-5725-00).

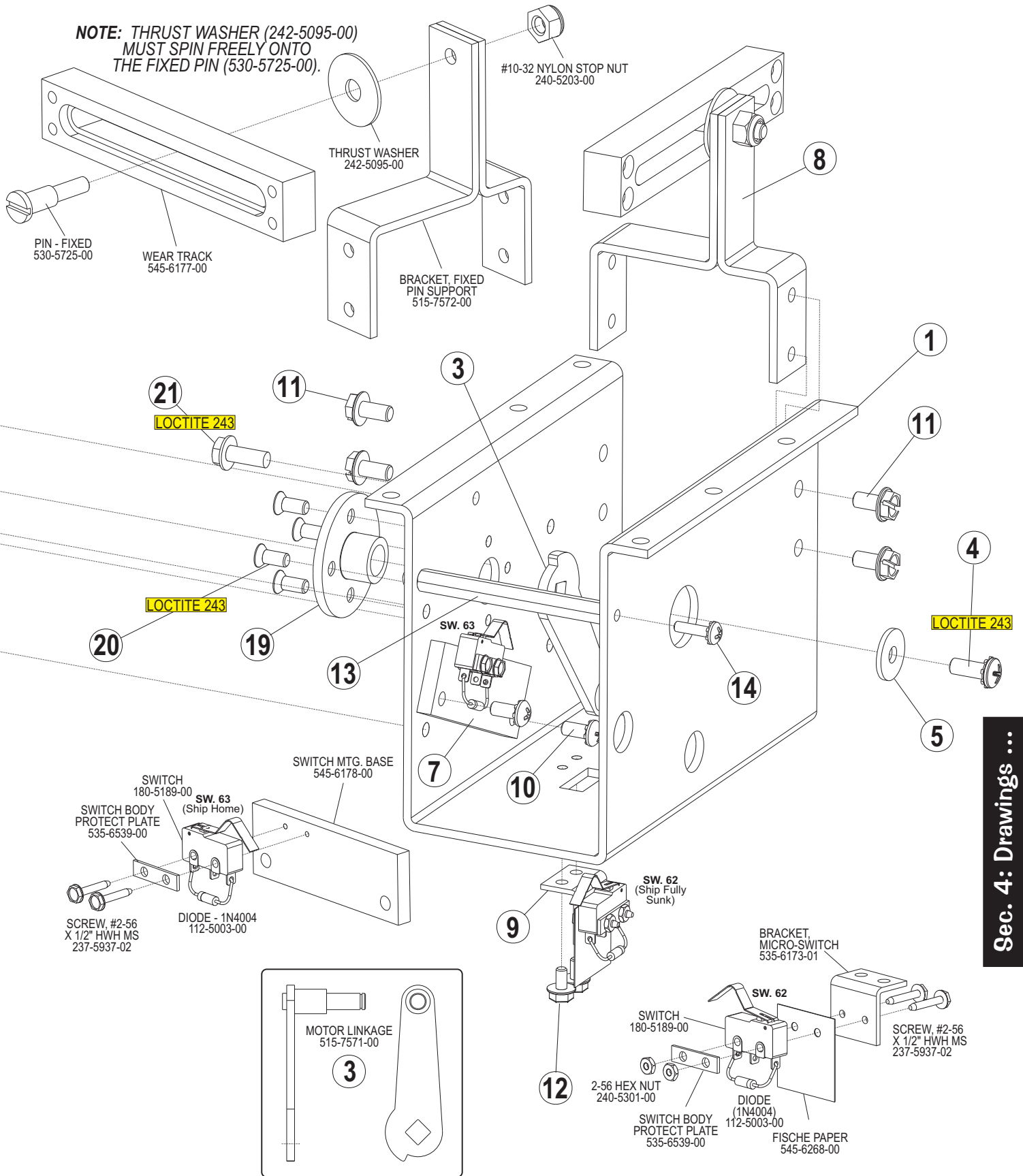

Sec. 4: Drawings ...



**Ship Hull Assembly,  
Individual Parts Only (Items 1-12)  
Part of the Ship Mechanical Assembly  
shown on Page 79.**

ITEM #	QTY	PART #	DESCRIPTION
1	1	515-7573-00	SHIP SUPPORT FRAME
2	1	500-7051-00	COIL (090-5044-ND-FC) + CONN. ASM.
3	1	500-7052-00	MINI-COIL (090-5074-03) + CONN. ASM.
4	1	515-7574-00	MINI COIL STOP PLATE ASSEMBLY
5	1	266-5077-00	COMPRESSION SPRING
6	1	515-7575-00	COIL STOP BRACKET ASSEMBLY
7	1	545-5411-00	COIL SLEEVE
8	1	535-9810-00	STIFFENER
9	1	500-6989-00	LATCH ASSEMBLY
10	1	500-7010-00	SAIL LINKAGE ASSEMBLY
11	12	237-5975-04	#8-32 X 1/4 HWH SWAGE SER SCREW
12	1	266-5020-00	COMPRESSION SPRING-CONICAL

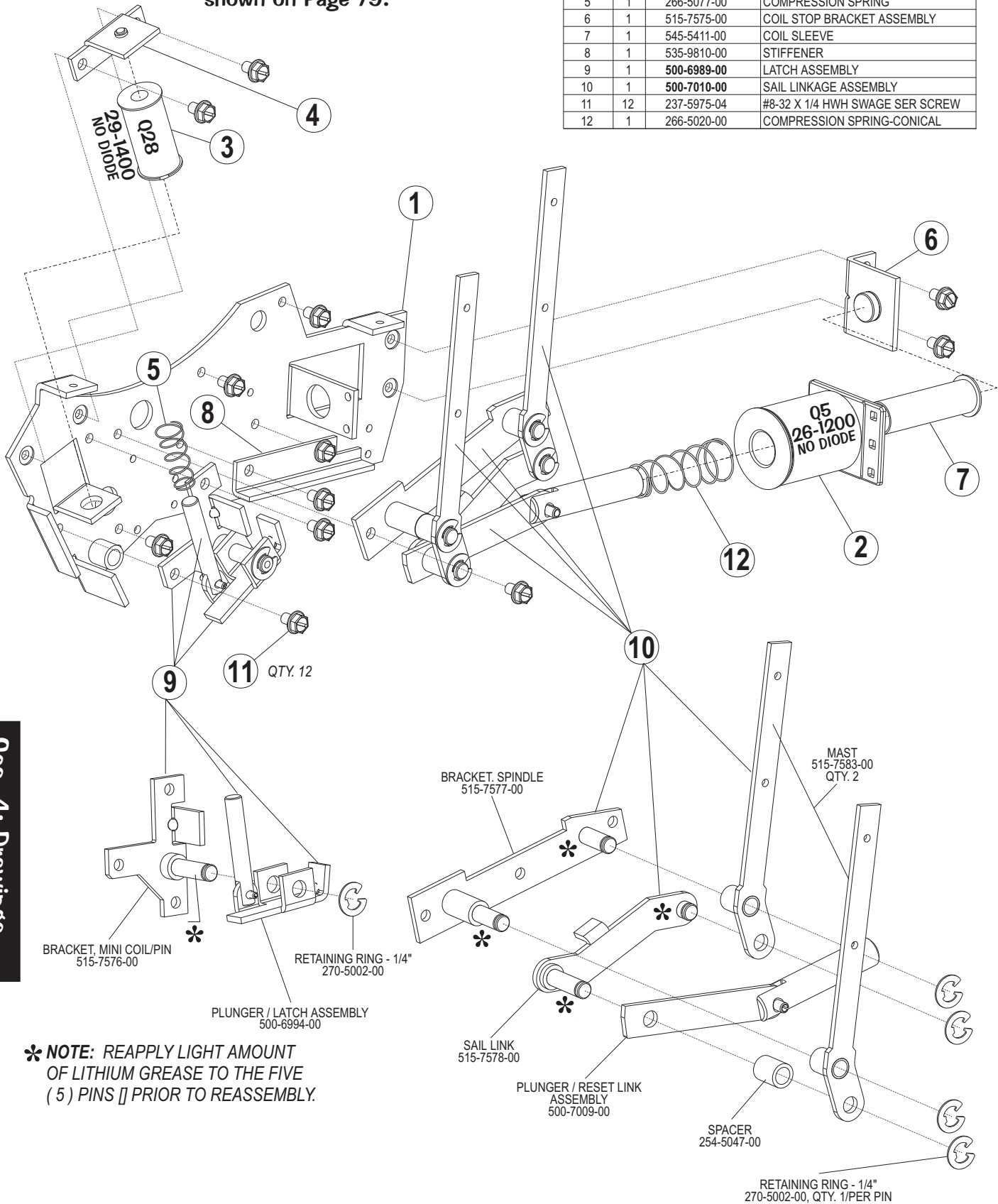

**\* NOTE: REAPPLY LIGHT AMOUNT OF LITHIUM GREASE TO THE FIVE (5) PINS [ ] PRIOR TO REASSEMBLY.**

Sec. 4: Drawings ...



# Pirate Ship Removal / Disassembly Procedure

For Parts Views and Part Numbers, see Pages 79-82.

With the playfield prepared for service (glass, pinballs, etc. removed), enter the Service Menu (details on **How To ... Page DR. 2** front of manual). Remember to have the **Power Interlock Switch** pulled out for the coils and motor to function. Enter the **DIAGNOSTICS MENU**, then **SHIP TEST MENU**. Press the **BLACK BUTTON** to drop the sails and lower the ship. **Note:** The **Switch Closure indicators** (for Sw. 63 & 62) let you know the switches are functioning properly.

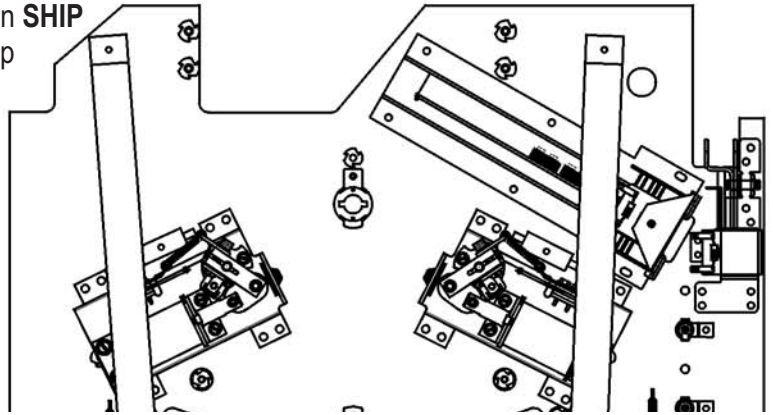
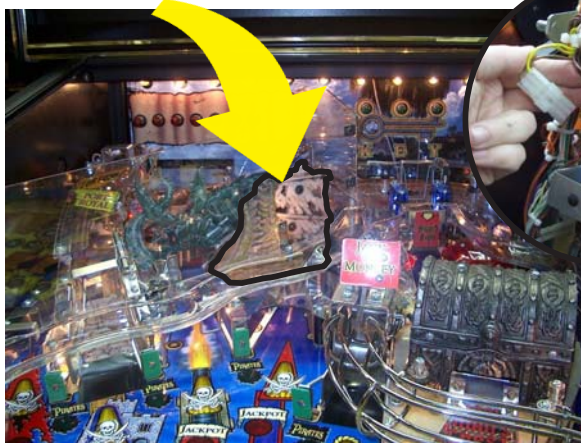
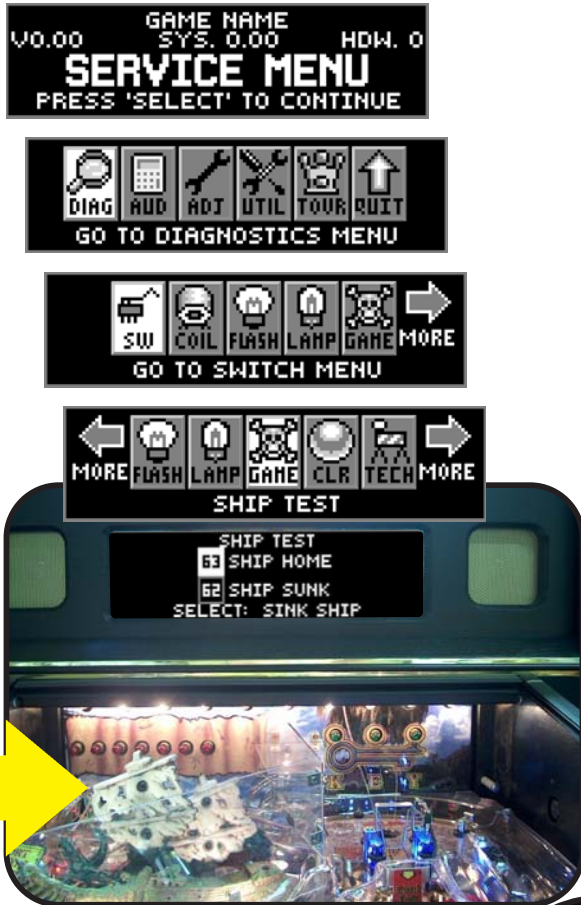

With the ship down, you can now power off the game and raise the playfield into the up position.

Disconnect the **MOTOR CONNECTOR (A)**; the **SWITCH CONNECTOR (B)** and the two (2) **COIL CONNECTORS (C)**.

Remove the six (6) screws (location indicated with the arrows below).

Carefully remove assembly. Reassemble in reverse.

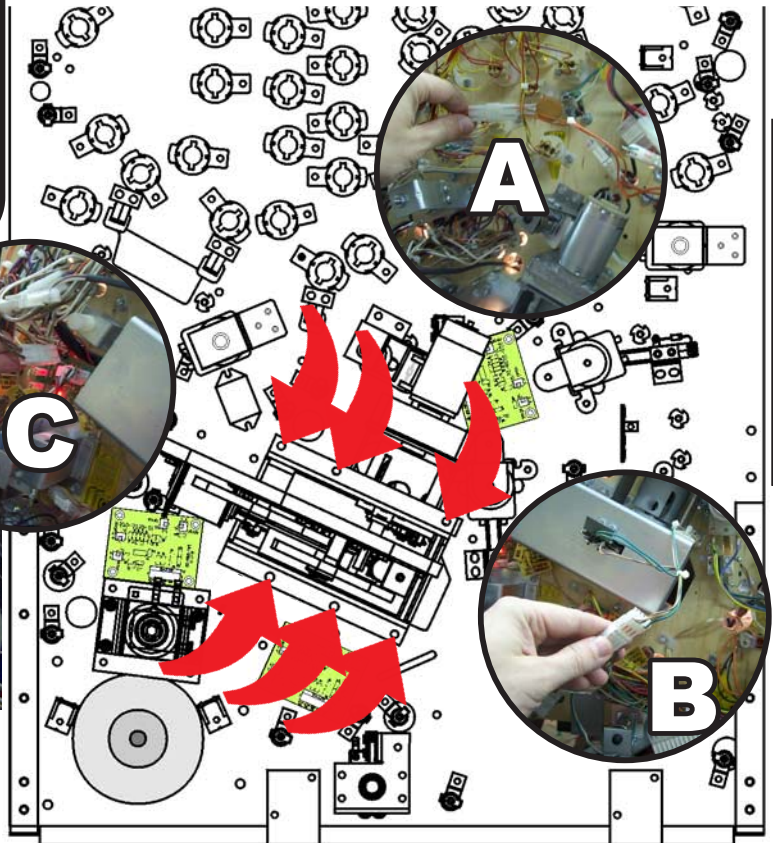

Sec. 4: Drawings ...

# Spinning Disk Assembly, Individual Parts Only (Items 1-21)

As the ball enters the Spinning Disk from the Left Ramp, it will exit when the Up/Down Post on the next page activates.

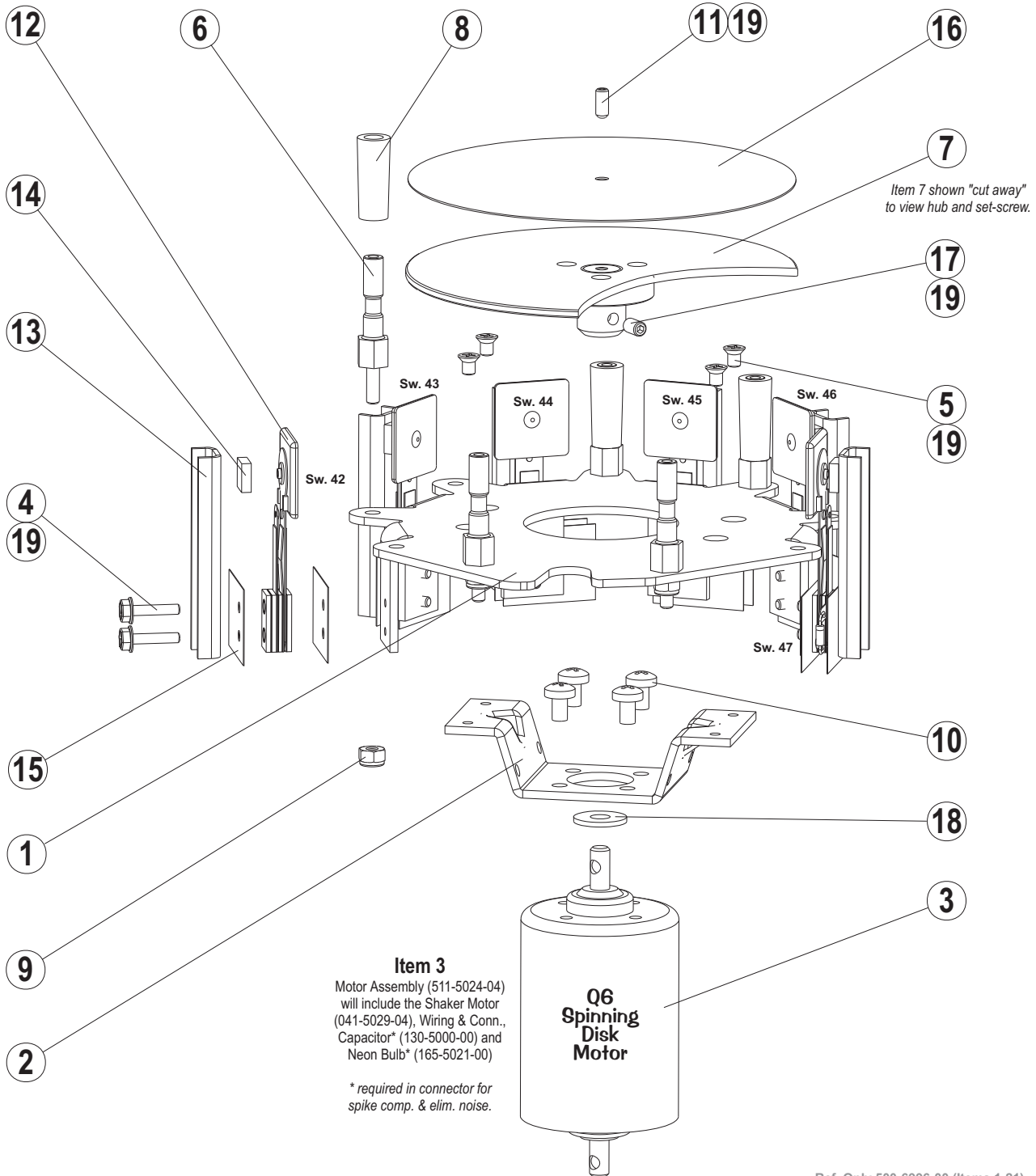

Ref. Only 500-6996-00 (Items 1-21)

ITEM NO.	QTY.	PART NO.	DESCRIPTION	ITEM NO.	QTY.	PART NO.	DESCRIPTION
1	1	535-9937-00	TARGET ARRAY MOUNTING PLATE	12	6	515-7497-06-01	1" SQ. TARG & SW ASSY -RT SIDE LUGS - YELLOW
2	1	535-9833-00	MOTOR BRACKET	13	6	535-9878-00	TARGET SUPPORT BRACKET
3	1	511-5024-04	MOTOR (041-5029-04) + CONN. ASM.	14	6	626-5029-00	FOAM PAD
4	12	237-5976-04	#6-32 X 5/8" HWH SWAGE SCREW	15	12	545-6024-02	INSULATOR-FISH PAPER
5	4	237-6030-02	8-32 x 1/4 PFH MS	16	1	820-6393-01	DECAL, SPINNING DISK
6	5	530-5753-00	HEX BUMPER POST GROOVED TALL	17	1	237-6092-00	#10-32 X 5/16 SOCKET SET SCREW
7	1	515-7619-00	DISK HUB WELDMENT	18	1	242-5028-00	WASHER NYLON .265 X .688 X .063
8	5	545-5308-00	POST - RUBBER - 3/8 O.D.	19	A.R.	000-0632-00	LOCTITE 243
9	5	240-5203-00	#10-32 NYLON LOCK NUT	20*	1	036-5517-05-92	CABLE SPINNING DISK TARGETS
10	4	237-6014-00	M5 X 0.8 X 8 PH SELF LOCKING SCREW	21*	4"	605-5006-00	CLEAR TUBING
11	1	237-5839-00	8-32 X 3/8 SET SCREW CUP				



# Up/Down Post Asm., Individual Parts Only (Items 1-12) & Spinning Disk Cover

When the ball is in the Spinning Disk, the Up/Down Post is energized to prevent the ball from exiting for a predetermined time period then drops back down to allow the ball to exit.

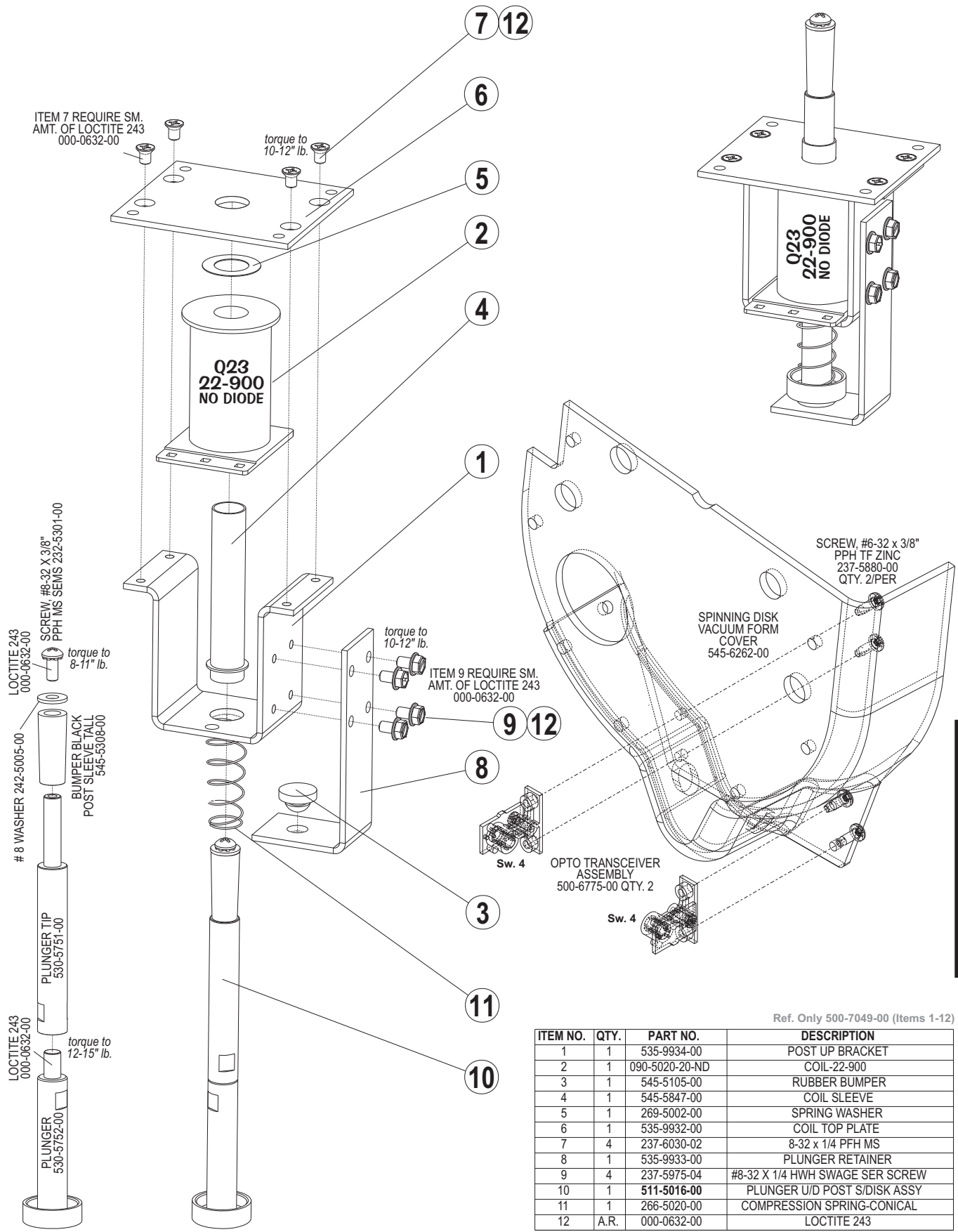

Sec. 4: Drawings ...

Ref. Only 500-7049-00 (Items 1-12)

ITEM NO.	QTY.	PART NO.	DESCRIPTION
1	1	535-9934-00	POST UP BRACKET
2	1	090-5020-20-ND	COIL-22-900
3	1	545-5105-00	RUBBER BUMPER
4	1	545-5847-00	COIL SLEEVE
5	1	269-5002-00	SPRING WASHER
6	1	535-9932-00	COIL TOP PLATE
7	4	237-6030-02	8-32 x 1/4 PFH MS
8	1	535-9933-00	PLUNGER RETAINER
9	4	237-5975-04	#8-32 X 1/4 HWH SWAGE SER SCREW
10	1	511-5016-00	PLUNGER U/D POST S/DISK ASSY
11	1	266-5020-00	COMPRESSION SPRING-CONICAL
12	A.R.	000-0632-00	LOCTITE 243



# Left Plastic Ramp Assembly, Individual Parts Only (Items 1-17)

The ball enters the Left Ramp, and exits onto the Spinning Disk.

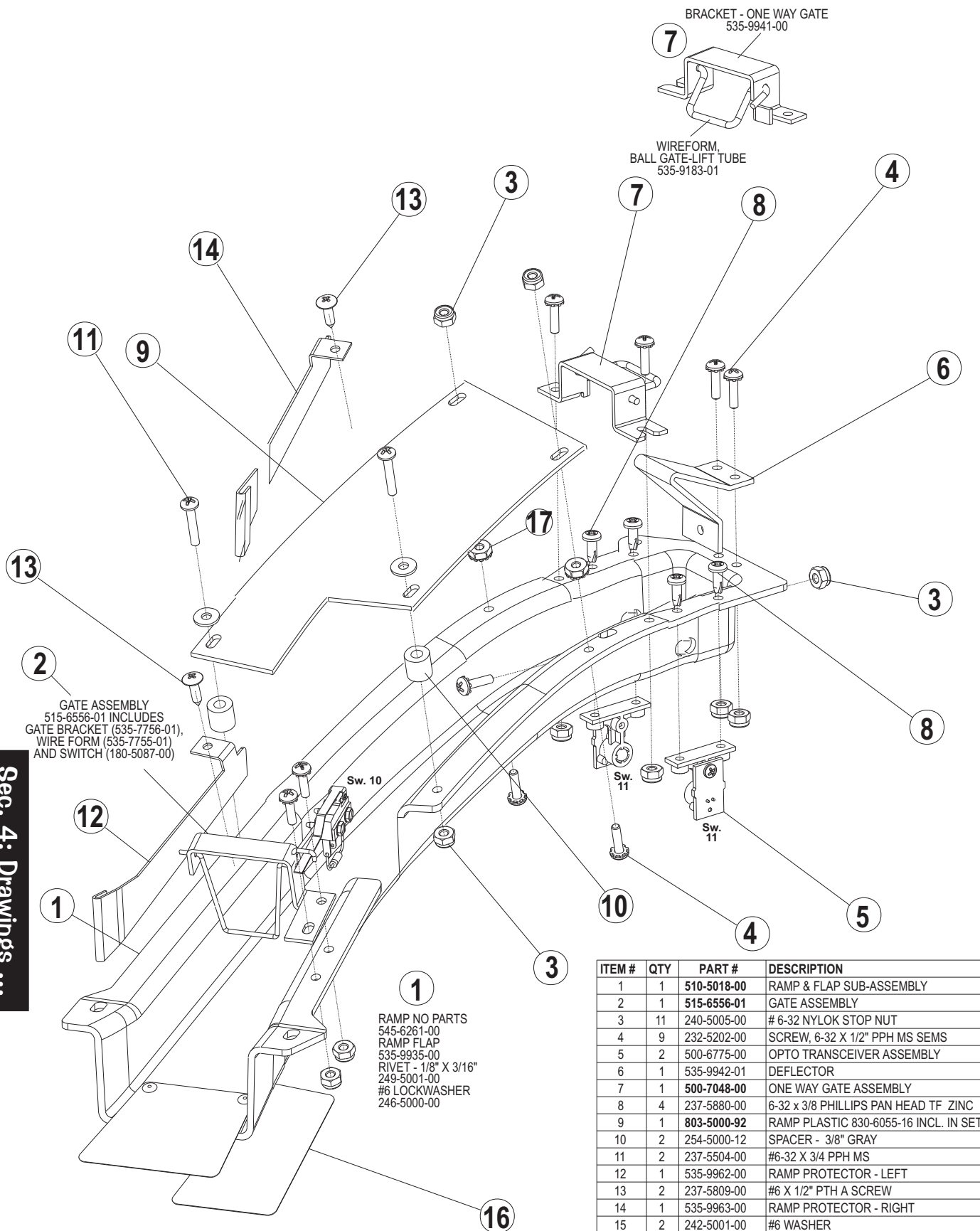

BRACKET - ONE WAY GATE  
535-9941-00

WIREFORM,  
BALL GATE-LIFT TUBE  
535-9183-01

GATE ASSEMBLY  
515-6556-01 INCLUDES  
GATE BRACKET (535-7756-01),  
WIRE FORM (535-7755-01)  
AND SWITCH (180-5087-00)

RAMP NO PARTS  
545-6261-00  
RAMP FLAP  
535-9935-00  
RIVET - 1/8" X 3/16"  
249-5001-00  
#6 LOCKWASHER  
246-5000-00

ITEM #	QTY	PART #	DESCRIPTION
1	1	510-5018-00	RAMP & FLAP SUB-ASSEMBLY
2	1	515-6556-01	GATE ASSEMBLY
3	11	240-5005-00	# 6-32 NYLOK STOP NUT
4	9	232-5202-00	SCREW, 6-32 X 1/2" PPH MS SEMS
5	2	500-6775-00	OPTO TRANSCEIVER ASSEMBLY
6	1	535-9942-01	DEFLECTOR
7	1	500-7048-00	ONE WAY GATE ASSEMBLY
8	4	237-5880-00	6-32 x 3/8 PHILLIPS PAN HEAD TF ZINC
9	1	803-5000-92	RAMP PLASTIC 830-6055-16 INCL. IN SET
10	2	254-5000-12	SPACER - 3/8" GRAY
11	2	237-5504-00	#6-32 X 3/4 PPH MS
12	1	535-9962-00	RAMP PROTECTOR - LEFT
13	2	237-5809-00	#6 X 1/2" PTH A SCREW
14	1	535-9963-00	RAMP PROTECTOR - RIGHT
15	2	242-5001-00	#6 WASHER
16	1	802-5000-92	DECAL LEFT RAMP INCL. IN DECAL SET
17	2	240-5008-00	# 6-32 KEPS NUT

Sec. 4: Drawings ...



# Reverse-O-Matic (Scoop) Assembly, Individual Parts Only (Items 1-5) & Right Wire Ramp, 515-7581-01

The ball enters the Scoop and exits on the Wire Ramp.

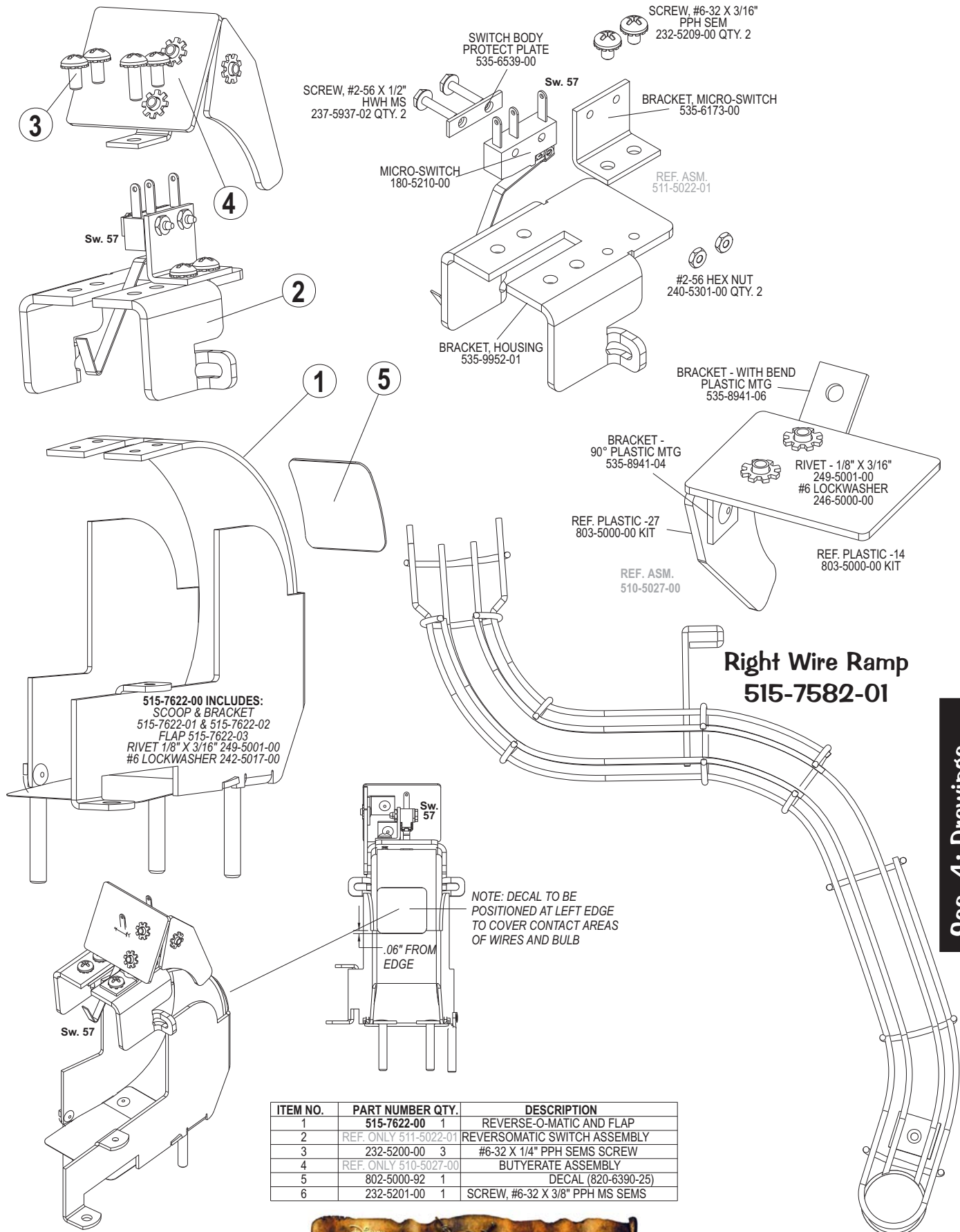

Sec. 4: Drawings ...



# Right Plastic Ramp Assembly, Individual Parts Only (Items 1-35 + Misc.)

Views continued on the next page.

Right Plastic Ramp & VUK Tube Wire Ramp Removal Overview on Page 90.

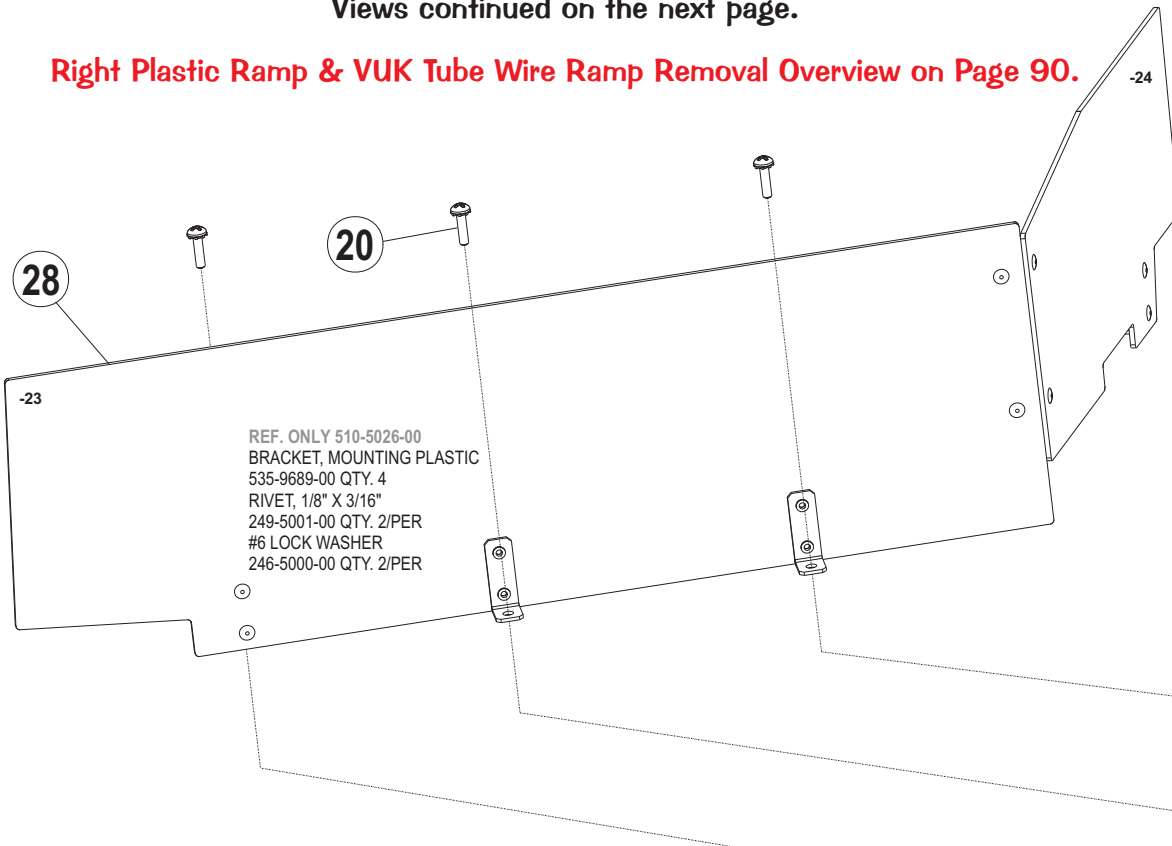

REF. ONLY ASM. 500-7007-00

\* ITEM NOT SHOWN

*	036-5717-16-92	CABLE POTC MAIN RAMP	1
*	040-5002-00	STICK CLAMP	2
*	040-5001-00	TIE WRAP	2
*	040-5000-03	CLAMP	1
35	232-5204-00	SCREW, 6-32 X 3/4" PPH SEMS	2
34	254-5000-01	SPACER - 1/2" GRAY	2
33	<b>KIT 803-5000-92</b>	PLASTIC -26 - RAMP EXIT CVR 830-6055-XX	1
32	<b>KIT 802-5000-92</b>	DECAL RAMP ISLAND 820-6390-22	1
31	<b>KIT 802-5000-92</b>	DECAL RAMP SCOOP 820-6390-21	1
30	<b>KIT 802-5000-92</b>	DECAL RAMP PLATFORM 820-6392-01	1
29	<b>KIT 803-5000-92</b>	PLASTIC -18 - RAMP RUBBER RING COVER	1
28	<b>KIT 803-5000-92</b>	ASM., PLASTIC -23 -24 SHIP ENCLOSURE	1
27	240-5301-00	#2-56 HEX NUT	4
26	077-5003-00	SOCKET - SHORT LAYDOWN 2-LUG	1
25	545-5348-21	RUBBER RING 1 3/4" ID BLACK	1
24	545-5348-02	5/16" ID RUBBER RING	2
23	545-5348-01	3/16" ID RUBBER RING	3
22	242-5001-00	#6 WASHER	20
21	240-5005-00	# 6-32 NYLOK STOP NUT	19
20	232-5202-00	SCREW, #6-32 X 1/2" PPH MS SEMS	9
19	237-5516-00	SCREW, #6-32 X 1-5/8" PPH	8
18	550-5059-01	PLASTIC POST - CLEAR	4
17	237-5937-02	#2-56 X 1/2" HWH MS SCREW	6
16	112-5003-00	DIODE - 1N4004	3
15	535-6539-00	SWITCH BODY PROTECT PLATE	3
14	180-5087-00	SWITCH - GATE (MIDDLE LANE)	1
13	180-5183-00	SWITCH - (LEFT & RIGHT LANES)	2
12	535-9936-00	VUK TUBE-WIRE FRAME	1
11			
10	<b>515-7635-00</b>	BRACKET, LANE GATE & WIRE R/U ASM.	1
9	112-5026-00	LED 5V WHITE-BLU TINT - #91-10BB-61W	3
8	077-5002-00	SOCKET - SHORT STAND-UP 2-LUG	2
7	550-5061-05	MINI HOOD, BLUE	2
6			
5			
4	<b>515-7636-00</b>	BRACKET, ONE-WAY GATE & WIRE ASM.	1
3	<b>515-7637-00</b>	BRACKET, ONE-WAY GATE & WIRE ASM.	1
2	545-5105-00	RUBBER BUMPER	1
1	<b>510-5000-00</b>	MAIN RAMP & FLAP ASSY	1
ITEM	PART NUMBER	DESCRIPTION	QTY.

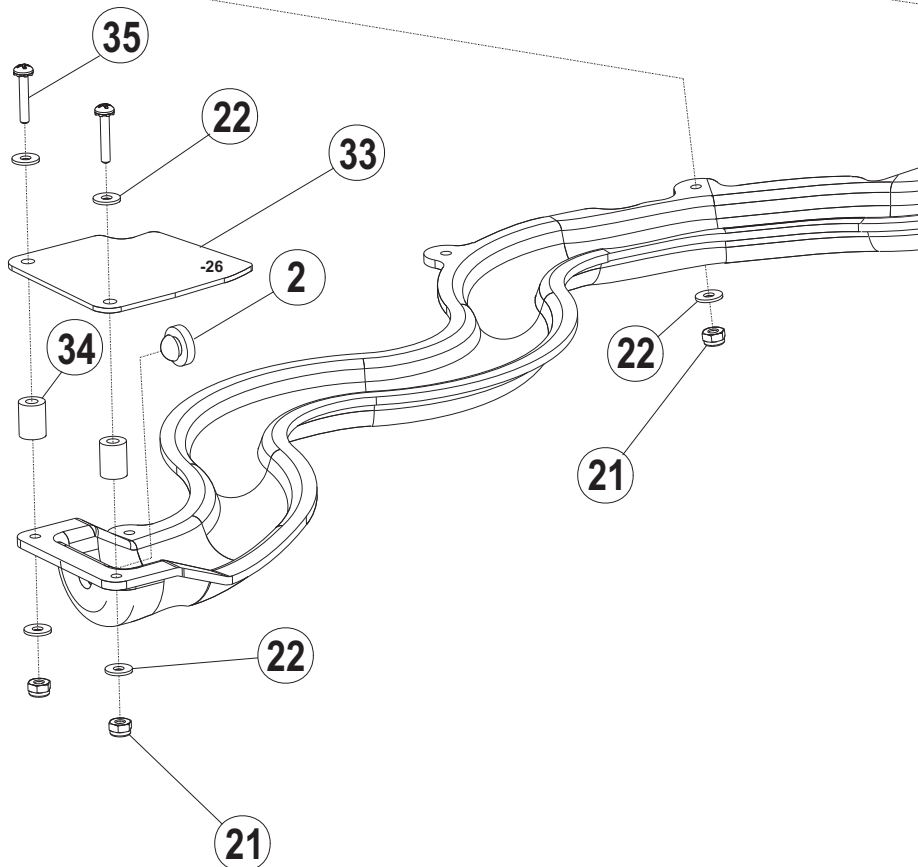

REFERENCE ONLY / DO NOT USE NUMBERS FOR ORDERING  
 ITEM 10 (+11) = 535-9949-00 + 535-7755-02  
 ITEM 4 (+6) = 535-9943-00 + 535-9853-00 (PREV. 535-5307-04)  
 ITEM 3 (+5) = 535-5269-02 + 535-5307-02

Sec. 4: Drawings ...





**Right Plastic Ramp Assembly, Individual Parts Only (Items 1-35 + Misc.) Continued**  
 Parts Table & Views continued on the previous page.

**Right Plastic Ramp & VUK Tube Wire Ramp Removal Overview on the next page.**

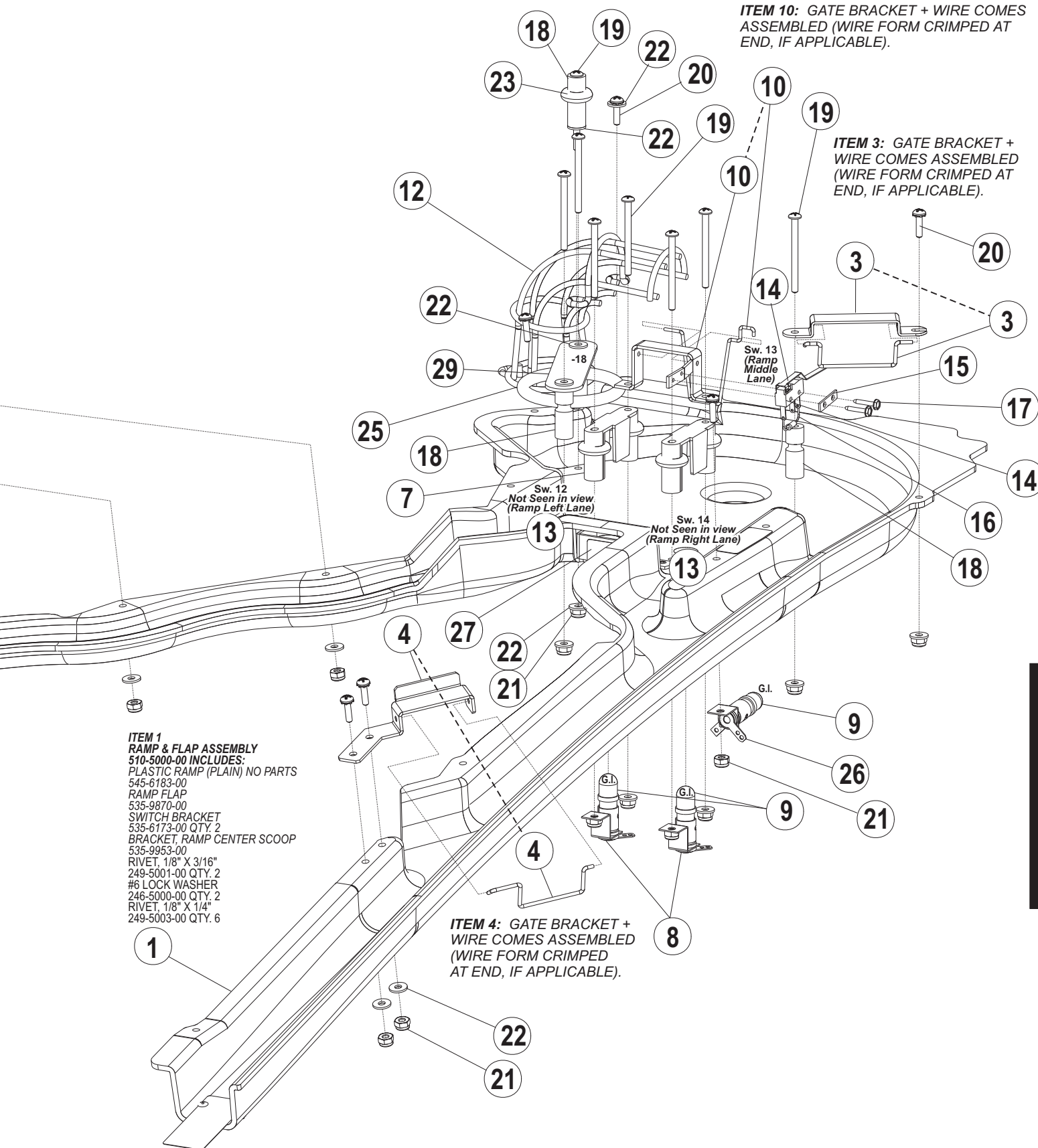

**ITEM 1**  
**RAMP & FLAP ASSEMBLY**  
 510-5000-00 INCLUDES:  
 PLASTIC RAMP (PLAIN) NO PARTS  
 545-6183-00  
 RAMP FLAP  
 535-9870-00  
 SWITCH BRACKET  
 535-6173-00 QTY. 2  
 BRACKET, RAMP CENTER SCOOP  
 535-9953-00  
 RIVET, 1/8" X 3/16"  
 249-5001-00 QTY. 2  
 #6 LOCK WASHER  
 246-5000-00 QTY. 2  
 RIVET, 1/8" X 1/4"  
 249-5003-00 QTY. 6

**Sec. 4: Drawings ...**



## Right Plastic Ramp & VUK Tube Wire Ramp Removal Overview

Remove the **7** screws indicated to remove the ramp

If ramp doesn't clear the plastic VUK Tube Wire Ramp Cover (shield), remove it from the back panel.

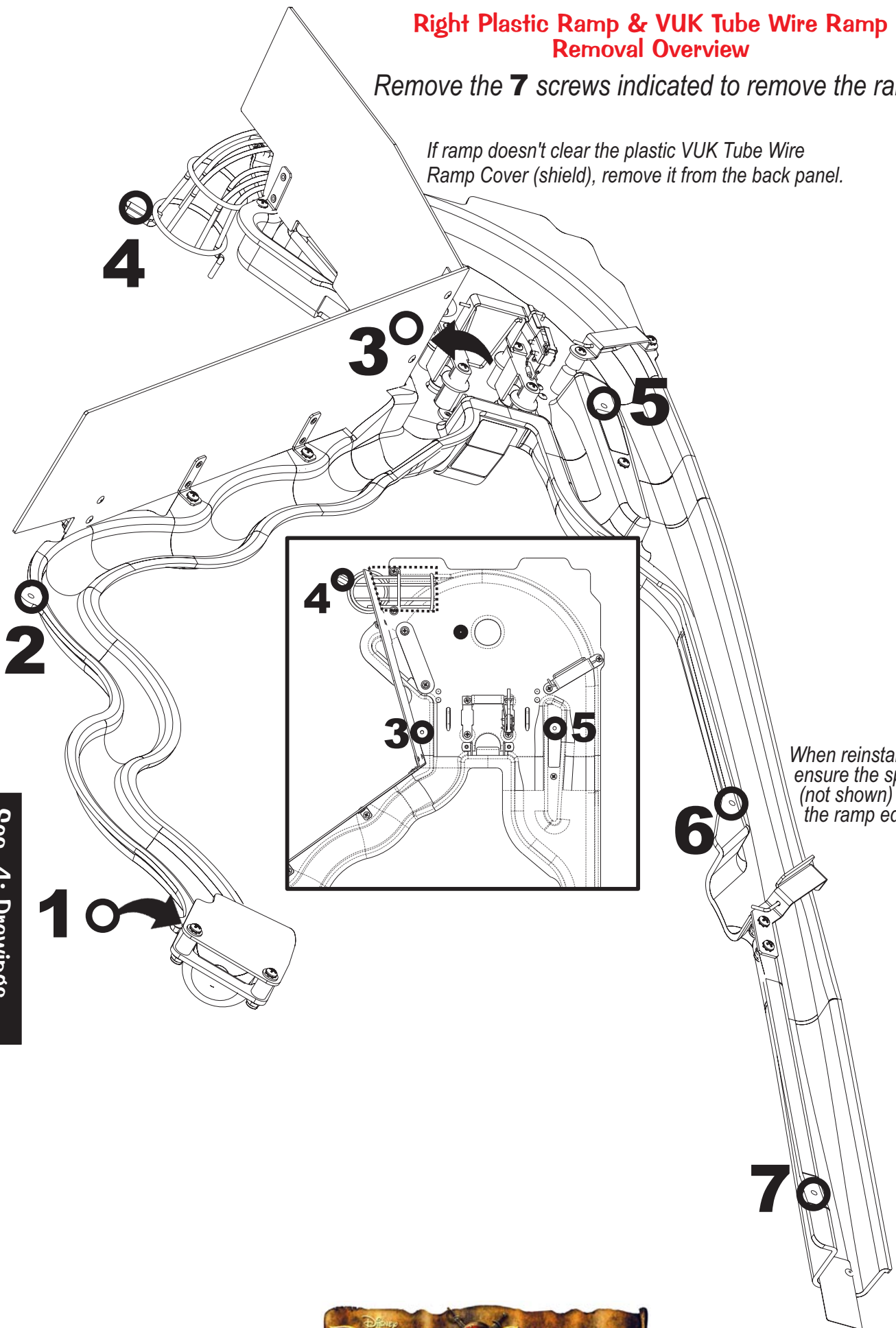

When reinstalling, ensure the spotlight (not shown) is above the ramp edge.

Ensure this edge goes under the black retaining bracket on the wood rail.

# Back Panel Assembly, Individual Parts Only (Items 1-9 + Misc.)

- 2** ITEM 2  
SOCKET, 2-LUG STAPLE DOWN  
077-5000-00 QTY. 10  
#44 BULB (CLEAR) HEAVY FILAMENT  
165-5000-44-HF QTY. 10
- 3** ITEM 3  
SOCKET, 3-LUG STAPLE DOWN  
077-5001-00 QTY. 7  
#44 BULB (RED) HEAVY FILAMENT  
165-5053-02-HF QTY. 7
- 4** ITEM 4  
SOCKET, 3-LUG STAPLE DOWN  
077-5001-00 QTY. 3  
#44 BULB (GREEN) HEAVY FILAMENT  
165-5053-04-HF QTY. 3
- 5** ITEM 5  
SOCKET, 2-LUG STAND-UP SHORT  
077-5101-00 QTY. 2  
#89 BULB (CLEAR) HEAVY FILAMENT  
165-5000-89-HF QTY. 2  
RUBBER RING (BLACK) 7/16" O.D.  
545-5348-17  
SCREW, #6 X 1/2" HWH  
234-5001-02

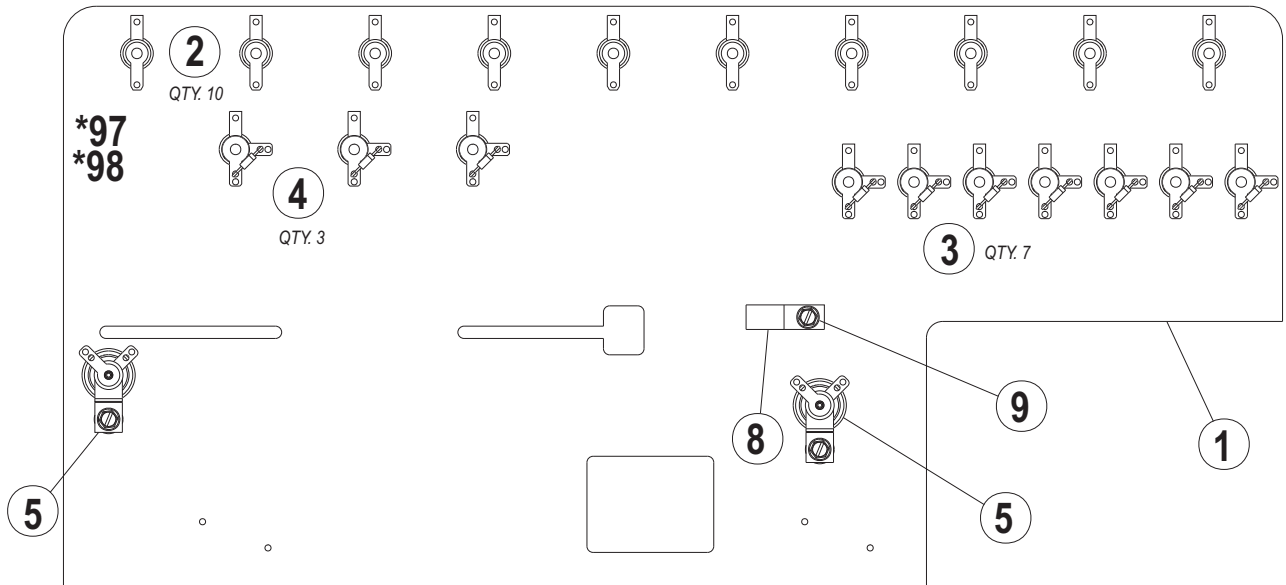
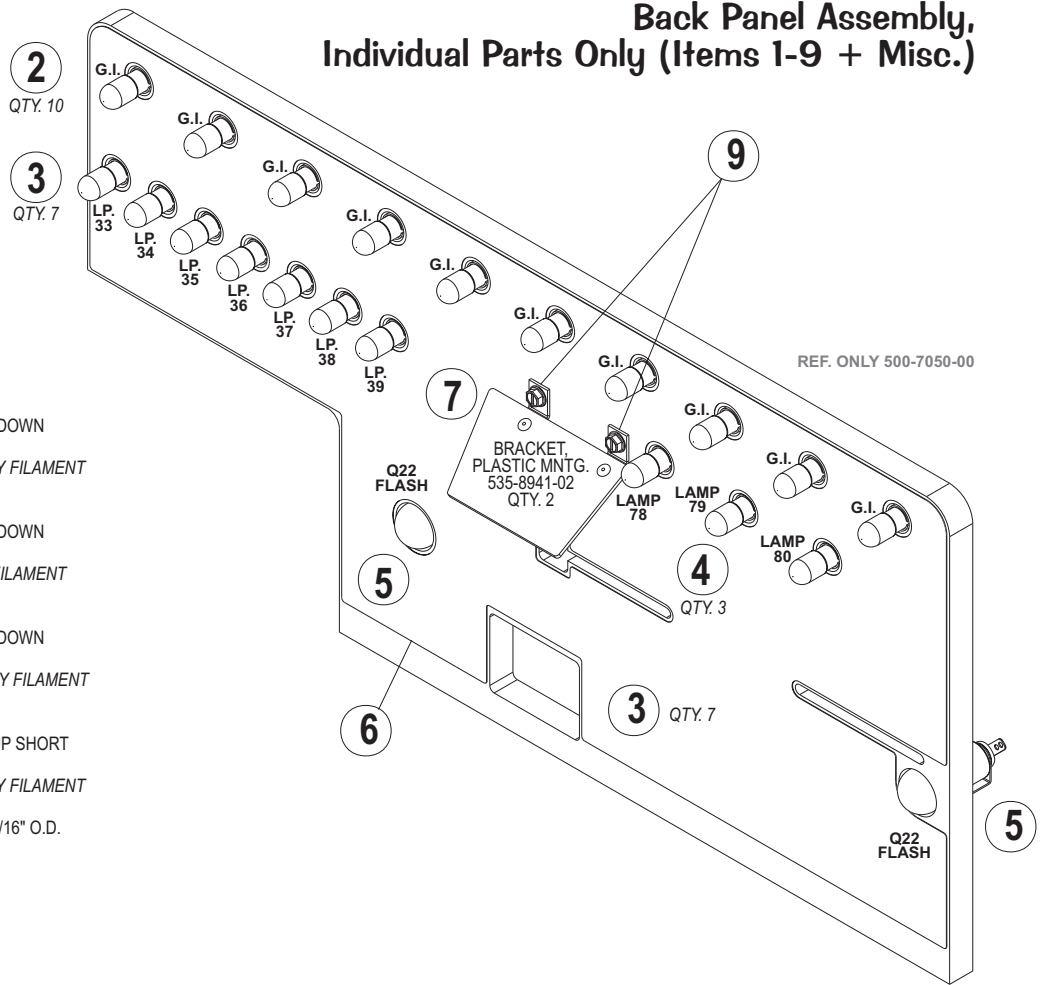

Sec. 4: Drawings ...

ITEM NO.	PART NUMBER	DESCRIPTION	QTY.
1	525-5660-00	BACK PANEL - POTC	1
2		SOCKET & BULB	10
3		SCKT & BULB 3-ASSY RED	7
4		SCKT & BULB 3-ASSY GREEN	3
5		SCKT & BULB & GROMMET	2
6	KIT 802-5000-92	DECAL BACK PANEL (820-6390-20)	1
7	KIT 803-5000-92	ASSY, PLASTIC -25 BACK PANEL	1
8	040-5000-06	1/2" CABLE CLAMP	1
*97	600-5003-00	BRAIDED WIRE - 20 GAUGE	3 FT.
*98	631-5000-00	STAPLE - 5/16	62
*99	036-5517-04-92	CABLE BACK PANEL POTC	1
9	234-5000-00	# 6 X 3/8" HWH SCREW	3

\* ITEM NOT SHOWN



SECURED BY:  
SCREW, #8 X 1/2"  
SHWH AB (ZINC)  
234-5101-00 (QTY. 1/PER TAB)

### Left Orbit Flat Rail

REF. ONLY 511-5023-00  
**FLAT RAIL #1**  
515-7620-01

### Under/Inside Chest 1-Way Gate Flat Rail

#### FLAT RAIL #13 & GATE BRACKET RIVETED ASSY

510-5020-13 WILL INCLUDE:

- FLAT RAIL  
535-9802-13
- 1-WAY GATE  
535-9956-00
- FLAP BLUE STEEL  
535-9955-00
- WIREFORM  
535-9947-00

1-WAY GATE  
535-9956-00

FLAP BLUE STEEL  
535-9955-00

WIREFORM  
535-9947-00

SECURED BY:  
SCREW, #8 X 1/2"  
SHWH AB (ZINC)  
234-5101-00 (QTY. 1/PER TAB)

SECURED BY:  
#8 WASHER  
242-5005-00 (QTY. 1/PER STUD)  
#8-32 NYLON STOP NUT  
240-5102-00 (QTY. 1/PER STUD)

2-56 X 1/2" HWH MS SCREW  
237-5937-02 QTY. 2

SWITCH BODY PROTECT PLATE  
535-6539-00

SW. 6 (CHEST LOCK)

MICRO-SWITCH - LIGHT ACTUATION  
180-5119-02

- GATE ASSEMBLY  
REF. ONLY 515-6556-01-92B
- GATE BRACKET (ONLY)  
535-7756-01
  - WIRE FORM GATE (ONLY)  
535-7755-01
  - MICRO SWITCH  
180-5087-00
  - SW. BODY PROTECT PLATE  
535-6539-00
  - SCREW, #2-56 X 1/2"  
237-5937-02
  - DIODE - 1N4004  
112-5003-00

SECURED BY:  
#8 WASHER  
242-5005-00 (QTY. 1/PER STUD)  
#8-32 NYLON STOP NUT  
240-5102-00 (QTY. 1/PER STUD)

### Under/Inside Chest Switch Flat Rail

**FLAT RAIL #14**  
535-9802-14  
for location see Page 52

SCREW, #6-32 X 3/8"  
PPH MS SEMS  
232-5201-00

SW. 8

Sec. 4: Drawings ...



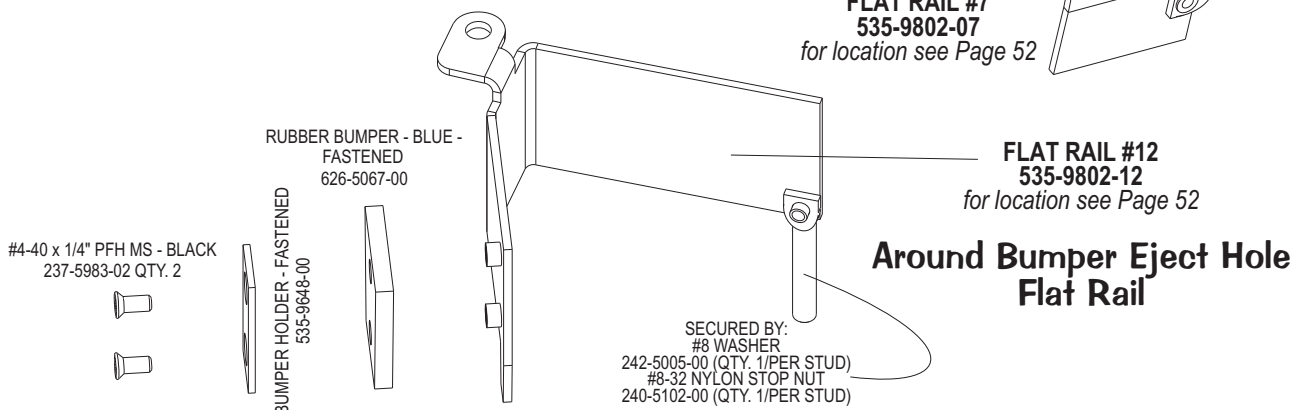
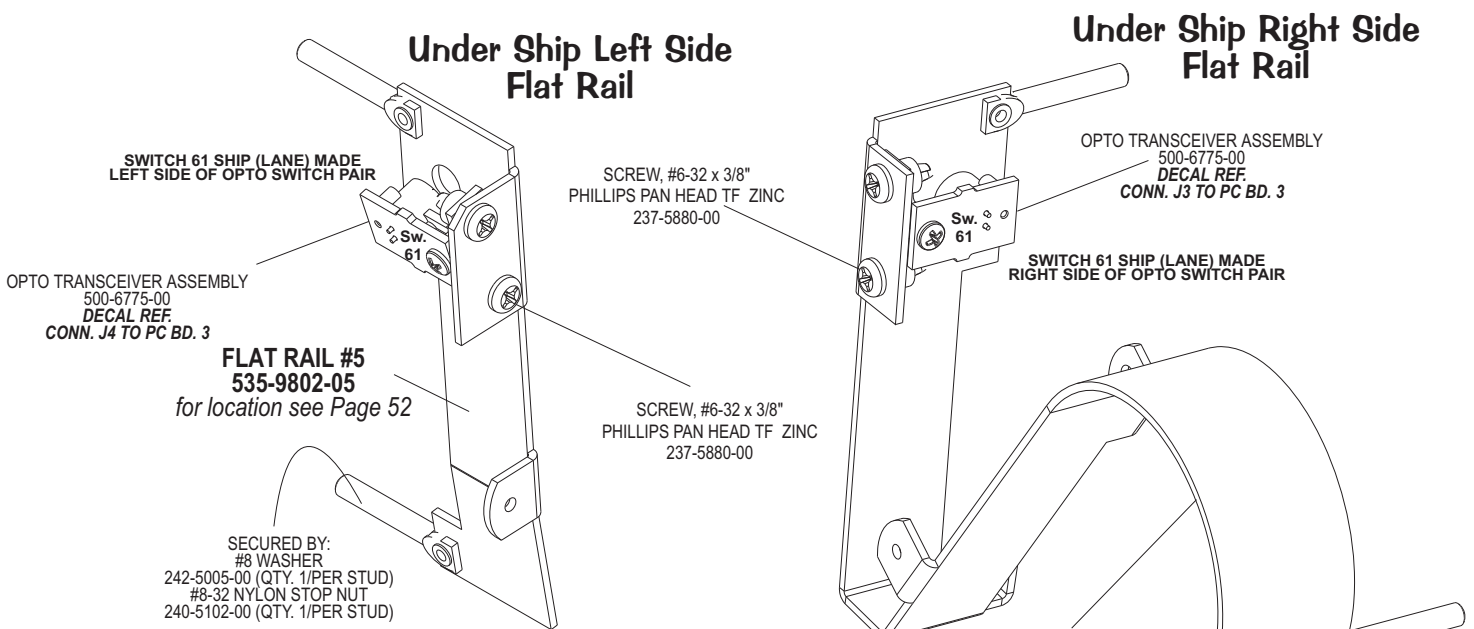
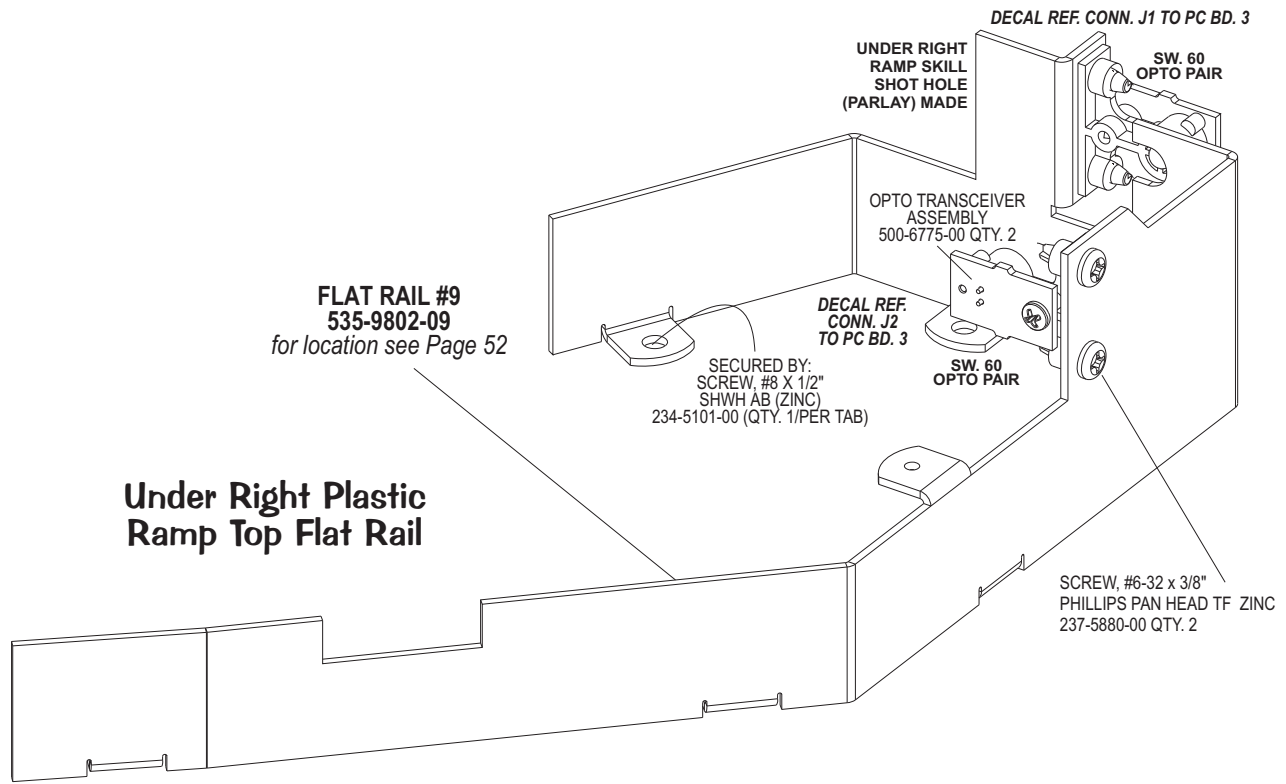

Sec. 4: Drawings ...





## Schematics, Wiring &amp; Printed Circuit Boards

Table of Contents  
for Section 5

<b>Chapter 1, Backbox Wiring</b> .....	<b>96 – 98</b>
▶ Table of Contents for Section 5.....	95
▶ Coils Detailed Chart Table.....	96
▶ Backbox I/O Power Driver Board Detailed Wiring Diagram.....	97
▶ Backbox Board Layout Wiring Diagram.....	98
<b>Chapter 2, Playfield Wiring</b> .....	<b>99 – 103</b>
▶ General Illumination Circuit Detailed Wiring Diagram.....	99
▶ Playfield Switch Wiring Diagram.....	100
▶ Playfield Lamp Wiring Diagram.....	101
▶ Playfield Terminal Strips, Fuses & Misc. Wiring Descriptions & Locations.....	102
▶ 2-Flipper Circuit Wiring Diagram.....	103
<b>Chapter 3, Cabinet and Coin Door Wiring</b> .....	<b>105 – 108</b>
▶ Transformer Power Wiring Diagram.....	105
▶ Cabinet Wiring Diagram.....	106
▶ Coin Door Wiring Diagram.....	107
<b>Chapter 4, Printed Circuit Boards (PCBs)</b> .....	<b>109 – 138</b>
▶ Trough Up-Kicker Dual OPTO PCBs (515-0173-00 & 515-0174-00) Theory of Op. & Schematic.....	(Top) 109
▷ Trough Up-Kicker Dual OPTO PCBs (515-0173-00 & 515-0174-00) Component Layout & Parts.....	(Bot) 109
▶ OPTO Troubleshooting.....	(Top) 110
▷ Trough Dual OPTO PCBs Alignment / Tests for LED1 & LED2.....	110-111
▶ I/O Power Driver PCB S.A.M. System (520-5249-00) Schematic (Sheet 1 of 4).....	112-113
▶ I/O Power Driver PCB S.A.M. System (520-5249-00) Schematic (Sheet 2 of 4).....	114-115
▶ I/O Power Driver PCB S.A.M. System (520-5249-00) Schematic (Sheet 3 of 4).....	116-117
▶ I/O Power Driver PCB S.A.M. System (520-5249-00) Schematic (Sheet 4 of 4).....	118-119
▷ I/O Power Driver PCB S.A.M. System (520-5249-00) Component Layout.....	120
▷ I/O Power Driver PCB S.A.M. System (520-5249-00) Parts.....	121
▶ CPU / Sound PCB S.A.M. System (520-5246-00) Schematic (Sheet 1 of 5).....	122-123
▶ CPU / Sound PCB S.A.M. System (520-5246-00) Schematic (Sheet 2 of 5).....	124-125
▶ CPU / Sound PCB S.A.M. System (520-5246-00) Schematic (Sheet 3 of 5).....	126-127
▶ CPU / Sound PCB S.A.M. System (520-5246-00) Schematic (Sheet 4 of 5).....	128-129
▶ CPU / Sound PCB S.A.M. System (520-5246-00) Schematic (Sheet 5 of 5).....	130-131
▷ CPU / Sound PCB S.A.M. System (520-5246-00) Component Layout.....	132
▷ CPU / Sound PCB S.A.M. System (520-5246-00) Parts.....	133
▶ Display Power Supply PCB (520-5138-00) Schematic.....	134
▷ Display Power Supply PCB (520-5138-00) Component Layout & Parts.....	134
▶ Playfield Switches OPTO Transceiver PCBs (500-6775-00) Schematic.....	(Top) 135
▷ Playfield Switches OPTO Transceiver PCBs (500-6775-00) Component Layout & Parts.....	(Top) 135
▶ Playfield OPTO Transmitter / Receiver Amplifier PCB (520-5239-01) Schematic.....	(Bot) 135
▷ Playfield OPTO Transmitter / Receiver Amplifier PCB (520-5239-01) Component Layout & Parts.....	(Top) 136
▷ Playfield OPTO Transmitter / Receiver Amplifier PCB (520-5239-01) Wiring (General).....	(Bot) 136
▷ Playfield Switches OPTO Transceivers & Transmitter / Receiver Amplifier PCB Locations.....	(Top) 137
▷ Playfield OPTO Transmitter / Receiver Amplifier PCB (520-5239-01) Wiring (Game Specific)	
Board 1: OPTO Switches 4 [Plunder Exit] & 11 [Plunder Enter].....	(Bot) 137
▷ Playfield OPTO Transmitter / Receiver Amplifier PCB (520-5239-01) Wiring (Game Specific)	
Board 2: OPTO Switch 3 [Hit (Treasure) Chest (Enter)].....	(Top) 138
▷ Playfield OPTO Transmitter / Receiver Amplifier PCB (520-5239-01) Wiring (Game Specific)	
Board 3: OPTO Switches 60 [Skill Hole Made] & 61 [Ship Made].....	(Bot) 138
▶ Treasure Chest H-E-A-R-T LED PCB (520-5238-00) Schematic.....	139
▷ Treasure Chest H-E-A-R-T LED PCB (520-5238-00) Component Layout (Lamps 24, 32, 40, 48, 56, 64 & 72).....	140
▶ Auxiliary (3X Transistor) Driver PCB (in Backbox) with the Coin/Ticket Meter and Ticket Disp. Wiring Diagram.....	141
▶ Auxiliary (3X Transistor) Driver PCB Schematic.....	(Top) 142
▷ Auxiliary (3X Transistor) Driver PCB Component Layout.....	(Bot) 142



Use the below **Coils Detailed Chart Table** in conjunction with **Sec. 5, Chp. 1, Backbox I/O Power Driver Board Detailed Wiring Diagram (I/O Board Connectors J6, J7, J8 & J9) and Backbox Board Layout Wiring Diagram:**

High Current Coils Group 1		Drive Transistor	Driver Output Board	Power Line Color	Power Line Connection	Power Voltage	Drive Transistor Control Line Color	D.T. Control Line Connect	Coil GA-Turn or Bulb Type
#1	TROUGH UP-KICKER	Q1	▲ I/O Power Driver ▼	YEL-VIO	J10-P9/10	50v DC	BRN-BLK	J8-P1	26-1200 ∪ 090-5044-00-ND
#2	AUTO LAUNCH	Q2		YEL-VIO	J10-P9/10	50v DC	BRN-RED	J8-P3	23-800 ∪ 090-5001-00-ND
#3	TOP CENTER VUK	Q3		YEL-VIO	J10-P9/10	50v DC	BRN-ORG	J8-P4	26-1200 ∪ 090-5044-00-ND
#4	CHEST LID	Q4		YEL-VIO	J10-P9/10	50v DC	BRN-YEL	J8-P5	27-1400 ∪ 511-5031-00
#5	RAISE SAILS	Q5		YEL-VIO	J10-P9/10	50v DC	BRN-GRN	J8-P6	26-1200 ∪ 500-7051-00
#6	PLUNDER DISK MOTOR	Q6		BROWN	J10-P9/10	20v DC	BRN-BLU	J8-P7	Motor 12V 511-5024-04
#7	NOT USED	Q7			J10-P9/10		BRN-VIO	J8-P8	
#8	NOT USED	Q8			J10-P9/10		BRN-GRY	J8-P9	

High Current Coils Group 2		Drive Transistor	Driver Output Board	Power Line Color	Power Line Connection	Power Voltage	Drive Transistor Control Line Color	D.T. Control Line Connect	Coil GA-Turn or Bulb Type
#9	LEFT BUMPER	Q9	▲ I/O Power Driver ▼	YEL-VIO	J10-P9/10	50v DC	BLU-BRN	J9-P1	26-1200 ∪ 090-5044-00-ND
#10	RIGHT BUMPER	Q10		YEL-VIO	J10-P9/10	50v DC	BLU-RED	J9-P2	26-1200 ∪ 090-5044-00-ND
#11	BOTTOM BUMPER	Q11		YEL-VIO	J10-P9/10	50v DC	BLU-ORG	J9-P4	26-1200 ∪ 090-5044-00-ND
#12	NOT USED	Q12			J10-P9/10		BLU-YEL	J9-P5	
#13	NOT USED	Q13			J10-P9/10		BLU-GRN	J9-P6	
#14	NOT USED	Q14			J10-P6/7		BLU-BLK	J9-P7	
#15	LEFT FLIPPER (50v RED/YEL)	Q15		GRY-YEL-3A Fuse-RED-YEL	J10-P6/7	50v DC	ORG-GRY	J9-P8	23-1100 ∪ 090-5030-00-ND
#16	RIGHT FLIPPER (50v RED/YEL)	Q16		BLU-YEL-3A Fuse-RED-YEL	J10-P6/7	50v DC	ORG-VIO	J9-P9	23-1100 ∪ 090-5030-00-ND

Low Current Coils Group 1		Drive Transistor	Driver Output Board	Power Line Color	Power Line Connection	Power Voltage	Drive Transistor Control Line Color	D.T. Control Line Connect	Coil GA-Turn or Bulb Type
#17	NOT USED	Q17	▲ I/O Power Driver ▼		J7-P1		VIO-BRN	J7-P2	
#18	POP BUMPER EJECT	Q18		BROWN	J7-P1	20v DC	VIO-RED	J7-P3	26-1200 ∪ 090-5044-00-ND
#19	CHEST KICKER	Q19		BROWN	J7-P1	20v DC	VIO-ORG	J7-P4	26-1200 ∪ 090-5044-00-ND
#20	FLASH: CHEST	Q20		ORANGE	J7-P1	20v DC	VIO-WHT	J7-P6	#89 Bulb 165-5000-89
#21	SHIP MOTOR	Q21		BROWN	J7-P1	20v DC	VIO-GRN	J7-P7	Motor 24V 041-5101-00
#22	FLASH: REAR CENTER (X2)	Q22		ORANGE	J7-P1	20v DC	VIO-BLU	J7-P8	#89 Bulb 165-5000-89
#23	PLUNDER PIN	Q23		BROWN	J7-P1	20v DC	VIO-BLK	J7-P9	22-900 ∪ 090-5020-20-ND
#24	OPTIONAL COIL	Q24		RED	J16-P4>8	5v DC	VIO-GRY	J7-P10	Opt. 5v

Diode On Terminal Strip (if noted)

Low Current Coils Group 2		Drive Transistor	Driver Output Board	Power Line Color	Power Line Connection	Power Voltage	Drive Transistor Control Line Color	D.T. Control Line Connect	Coil GA-Turn or Bulb Type
#25	LEFT SLINGSHOT	Q25	▲ I/O Power Driver ▼	BROWN	J6-P10	20v DC	BLK-BRN	J6-P1	23-800 ∪ 090-5001-00-ND
#26	RIGHT SLINGSHOT	Q26		BROWN	J6-P10	20v DC	BLK-RED	J6-P2	23-800 ∪ 090-5001-00-ND
#27	SHIP MOTOR RELAY	Q27		BROWN	J6-P10	20v DC	BLK-ORG	J6-P3	Relay PCB 511-5024-03
#28	LOWER SAILS LATCH	Q28		BROWN	J6-P10	20v DC	BLK-YEL	J6-P4	29-1400 ∪ 500-7052-00
#29	SHIP PIN [UP POST]	Q29		BROWN	J6-P10	20v DC	BLK-GRN	J6-P5	26-1200 ∪ 090-5044-00-ND
#30	FLASH: BACK RIGHT [X3]	Q30		ORANGE	J6-P10	20v DC	BLK-BLU	J6-P6	#89 Bulb 165-5000-89
#31	FLASH: BACK LEFT	Q31		ORANGE	J6-P10	20v DC	BLK-VIO	J6-P7	#89 Bulb 165-5000-89
#32	FLASH: SHIP	Q32		ORANGE	J6-P10	20v DC	BLK-GRY	J6-P8	#89 Bulb 165-5000-89

Note: In Test Flash Lamps Menu ("Flash" Icon), Flashers tested are all Flash Lamps located between Q1-Q32 (This Game: Q20, Q22, Q30, Q31 & Q32)

∪ Coil Note: ∪ -ND means 'No Diode'. -00B or -00T can be used for coil replacements, but the diode must be removed. Call for more info.

Sec. 5: Schematics...





# Backbox I/O Power Driver Board (Coils Q1-Q32) Detailed Wiring Diagram

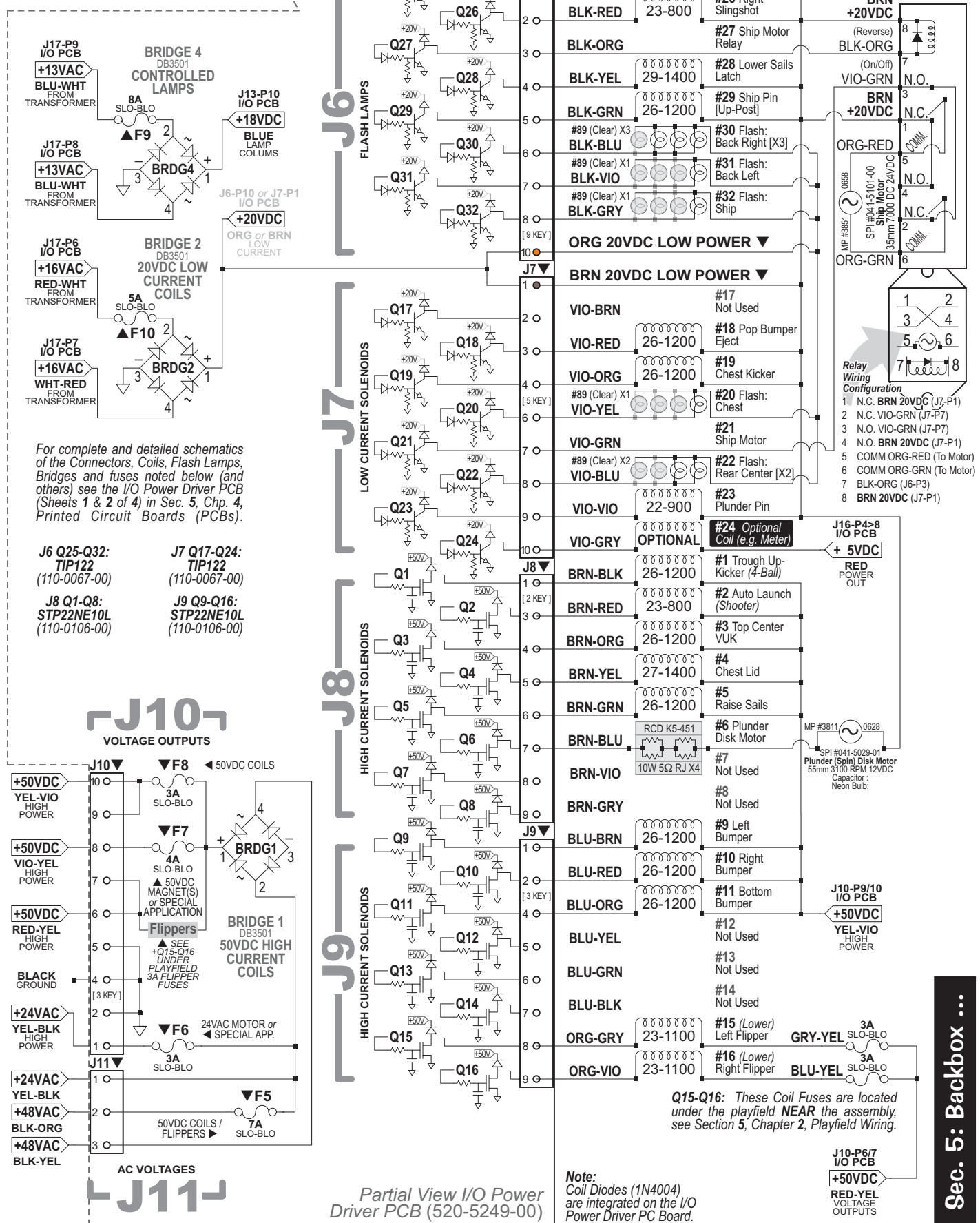

# Backbox Board Layout Wiring Diagram

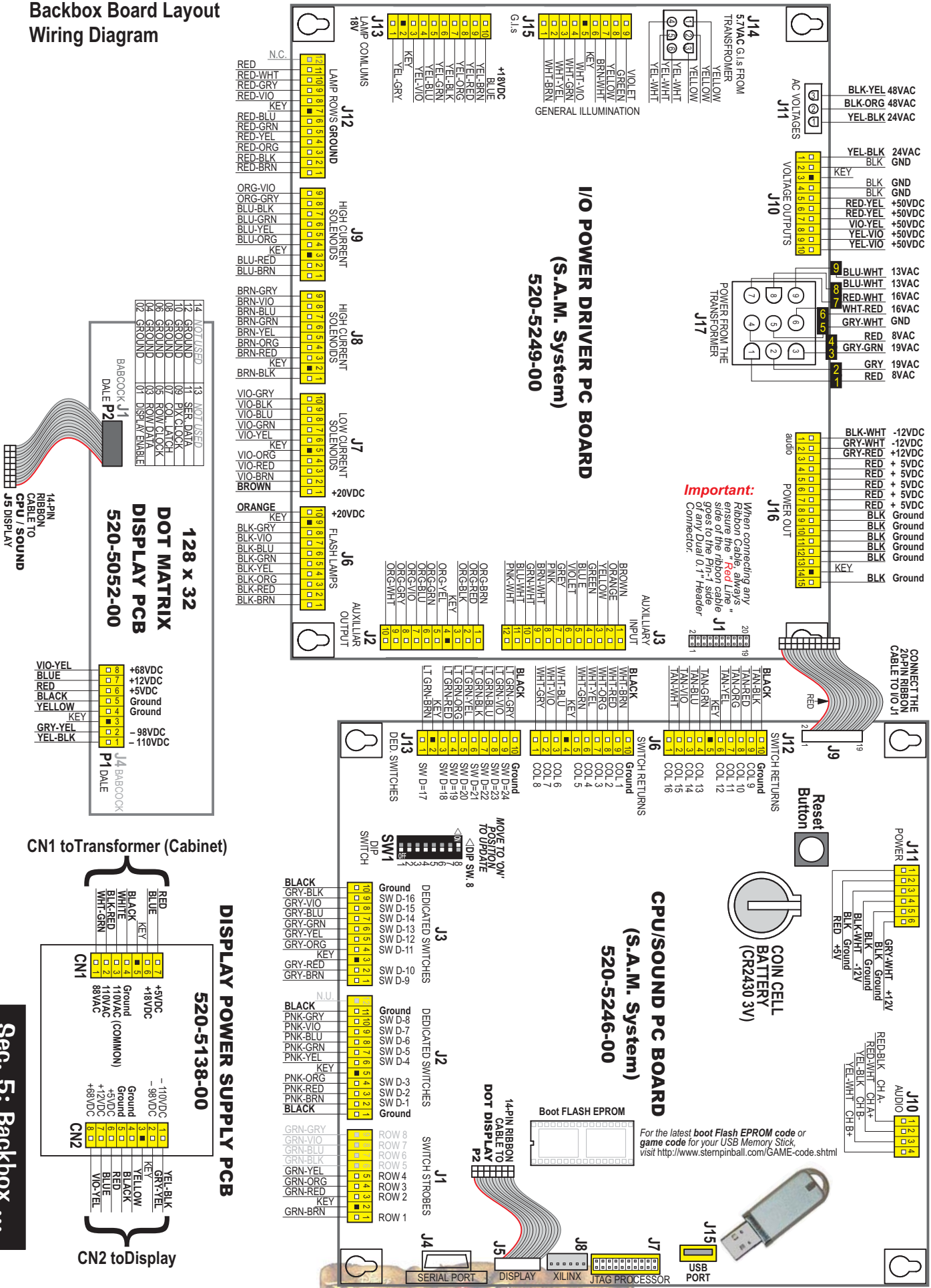

# Playfield Wiring

## General Illumination Circuit Detailed Wiring Diagram

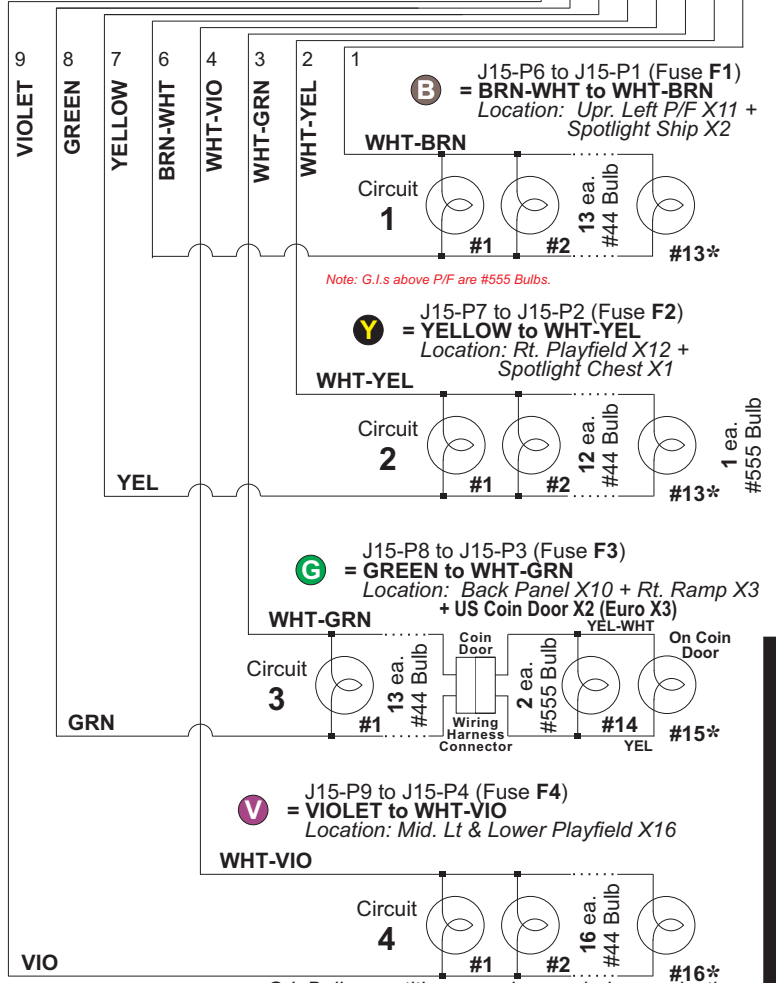
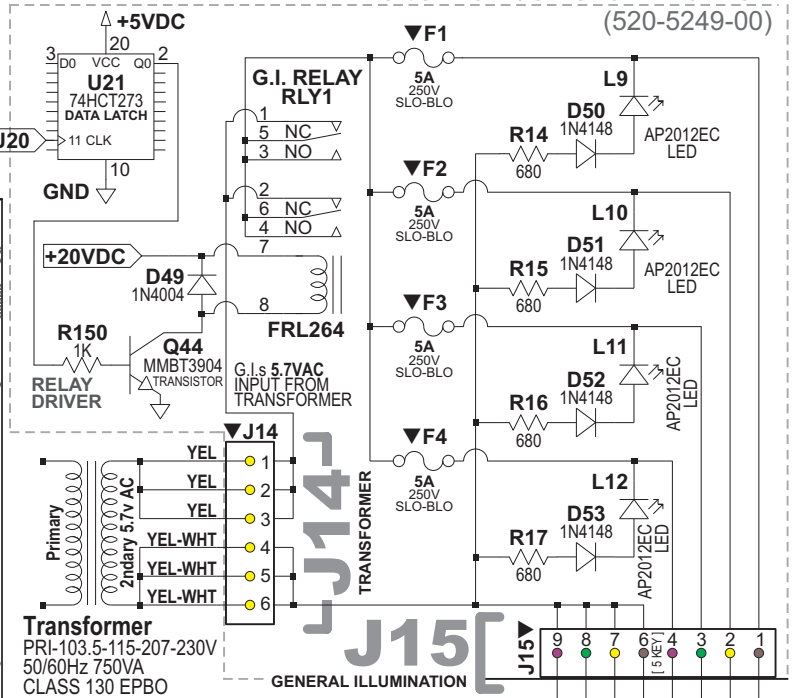
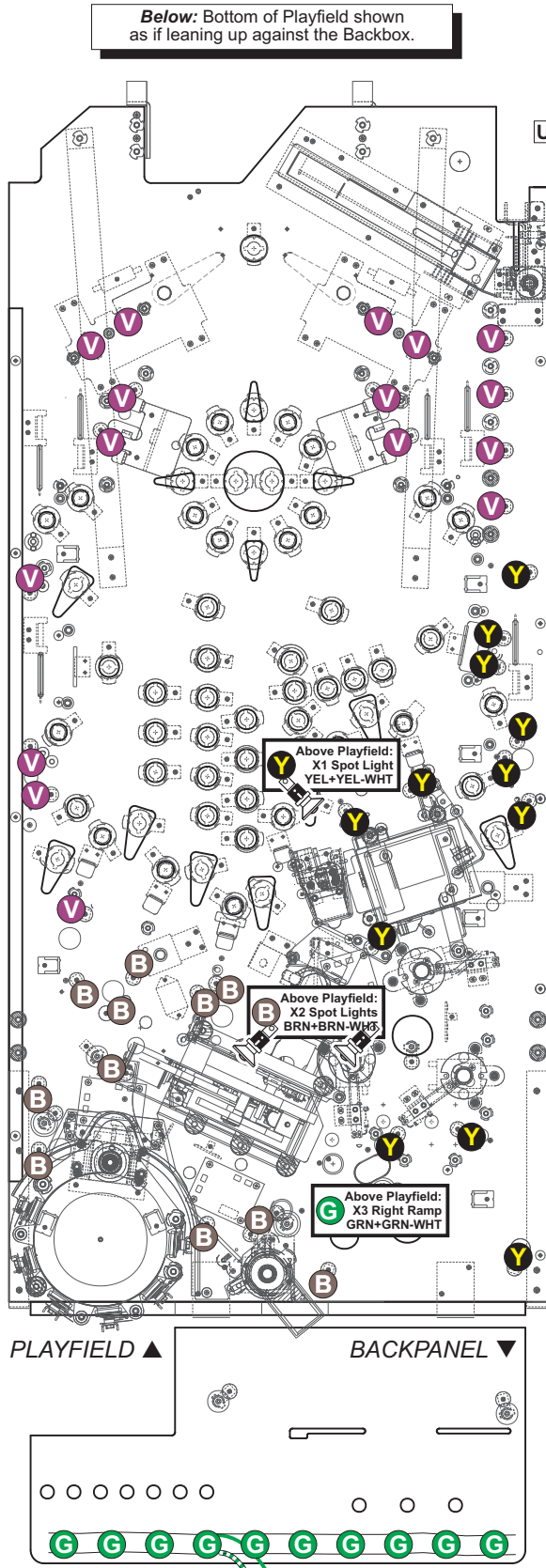

Sec. 5: Playfield ...



# Playfield Switch Wiring Diagram



Please Note: Switch & Lamp Descriptions may differ slightly from that of the DotDisplay due to space restraints.

Note: All Switch, Lamp & Coil assemblies require diodes. Some diodes are located under the playfield on Terminal Strips or Diode Boards and not on the assemblies.

For Switch:  
 O T B  
 O n S  
 - or -  
 B icde  
 O n  
 T terminal  
 S Strip

## Sec. 5: Playfield ...



# Playfield Lamp Wiring Diagram

Please Note: Switch & Lamp Descriptions may differ slightly from that of the Dot Display due to space restraints.

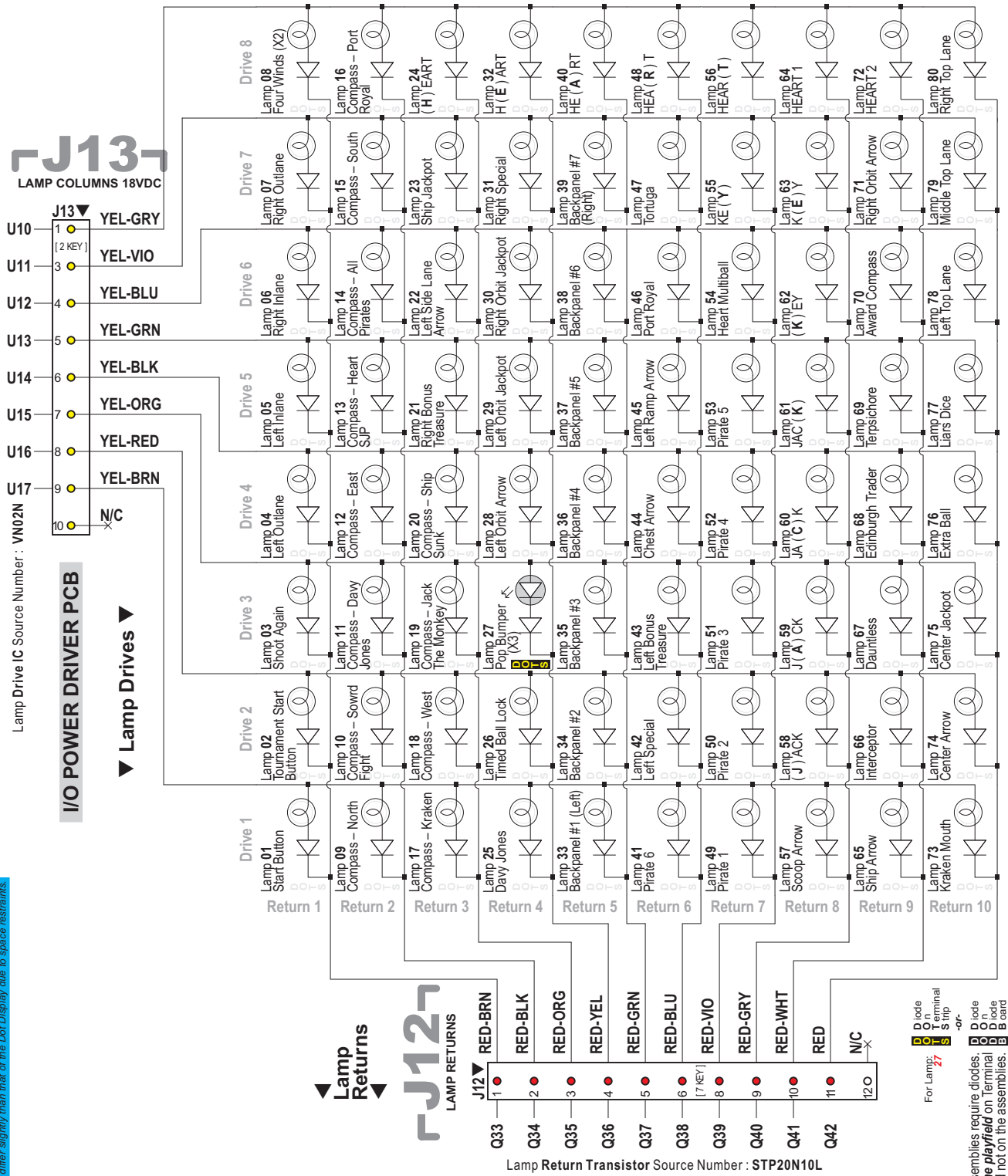

# Playfield Terminal Strips, Fuses & Misc. Wiring Descriptions & Locations

Please Note: Terminal Strip(s), Diode Board(s) and/or Fuse Holder(s) locations shown, represent the general location (your game may differ slightly).

Bottom of Playfield shown as if leaning up against the Backbox.

All fuses are rated:  
**3A 250v Slo-Blo**  
Do Not Over-Fuse

## Explanation:

All Switch, Lamp & Coil assemblies require diodes. Some diodes are **located under the playfield** on Terminal Strips **or** Diode Boards and not on the assemblies. The Switch and Lamp Matrix Grids also note which Switch or Lamp has a diode on a Terminal Strip (noted by **"DOTS"** meaning: **"Diode On Terminal Strip"**) or on a Diode Board (noted by **"DODB"** meaning: **"Diode On Diode Board"**).

**LOWER LEFT FLIPPER FUSE**  
RED -YEL 3A S.B. GRY-YEL

**LOWER RIGHT FLIPPER FUSE**  
RED -YEL 3A S.B. BLU-YEL

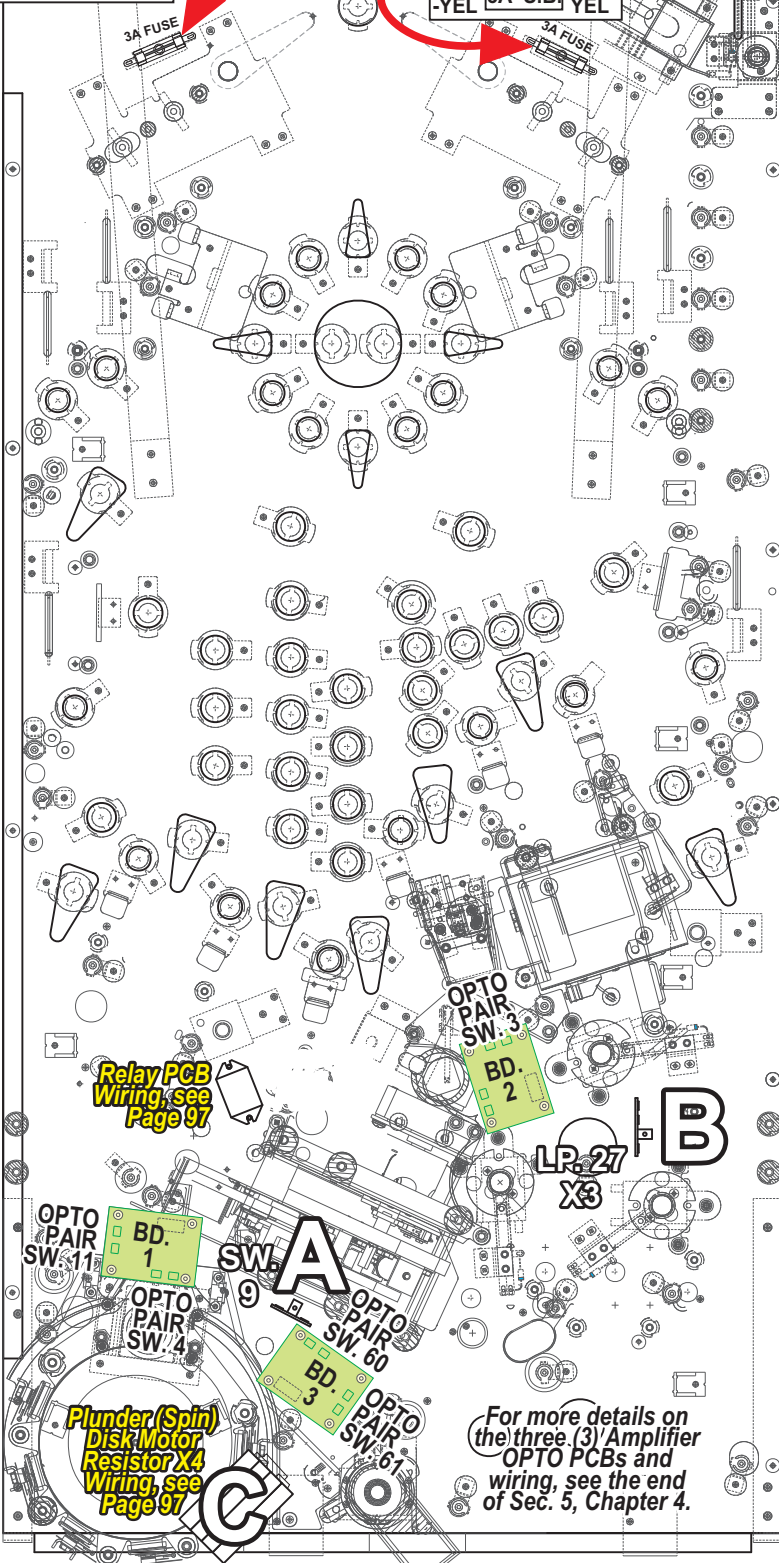

Relay PCB Wiring, see Page 97

Plunder (Spin) Disk Motor Resistor X4 Wiring, see Page 97

For more details on the three (3) Amplifier OPTO PCBs and wiring, see the end of Sec. 5, Chapter 4.

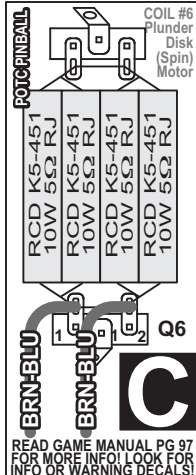
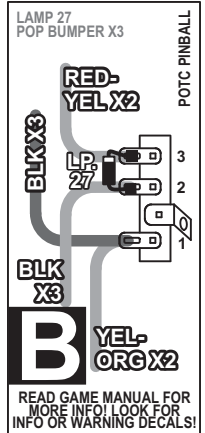
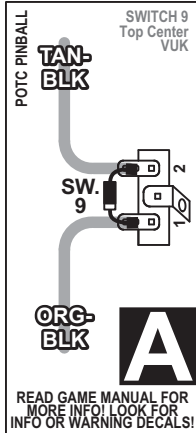

Sec. 5: Playfield ...

See the Pink Pages, Playfield Bottom - Misc. Parts and Brackets for Terminal Strips, Diodes, Fuses and Fuse Holders Part Numbers.



## 2- Flipper Circuit Wiring Diagram

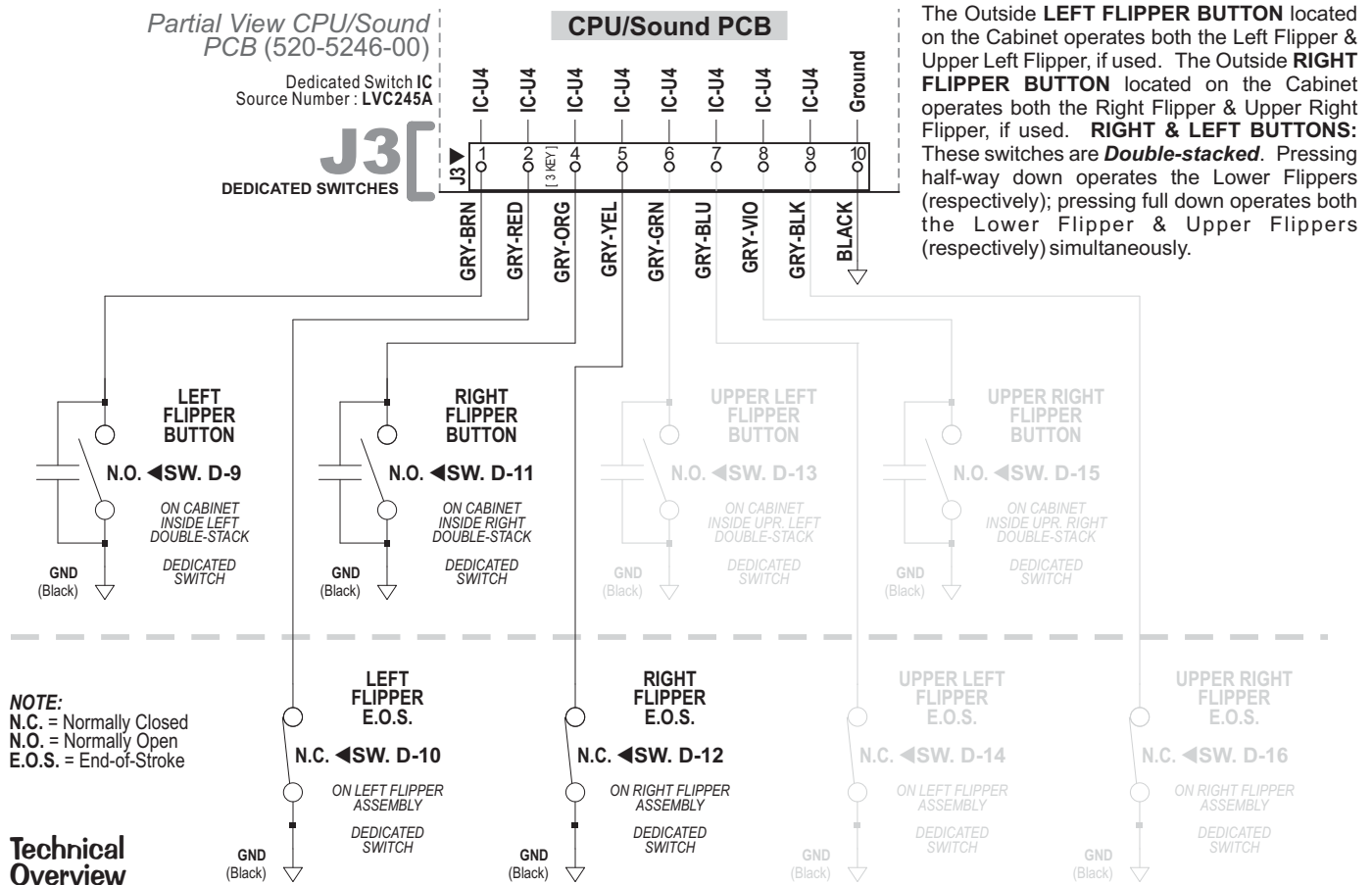

Our **Flipper System** uses one supply voltage (+50VDC) for both **kick & hold**. Once the **Game CPU** detects a Flipper Cabinet Switch closure (*during game play*) it applies a 40msec pulse to the gate of the Flipper Drive Transistor (STP22NE10L). If it continues to detect a Flipper Cabinet Switch closure (*the player holding the button in*) it will continue to pulse the flipper drive transistor 1msec every 12msecs for the duration of the hold cycle.

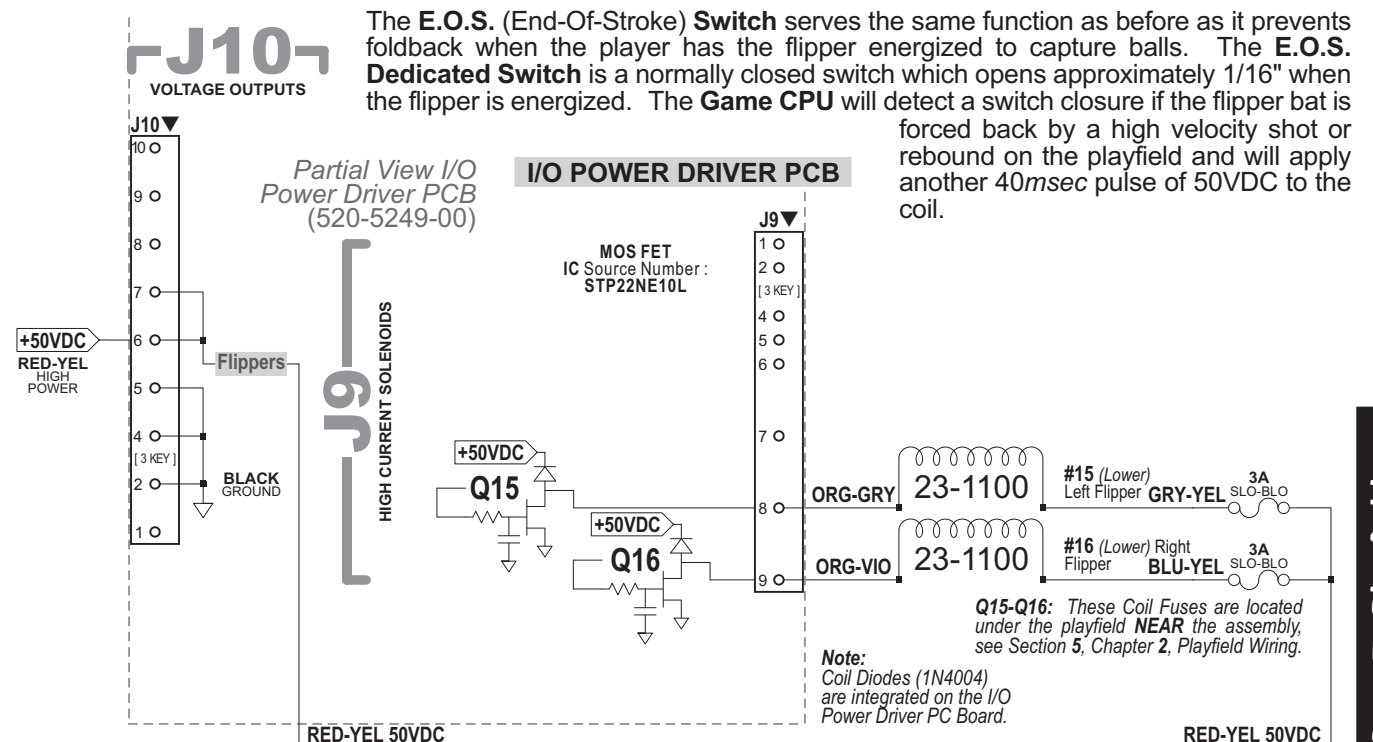





# Cabinet and Coin Door Wiring

## Transformer Power Wiring Diagram

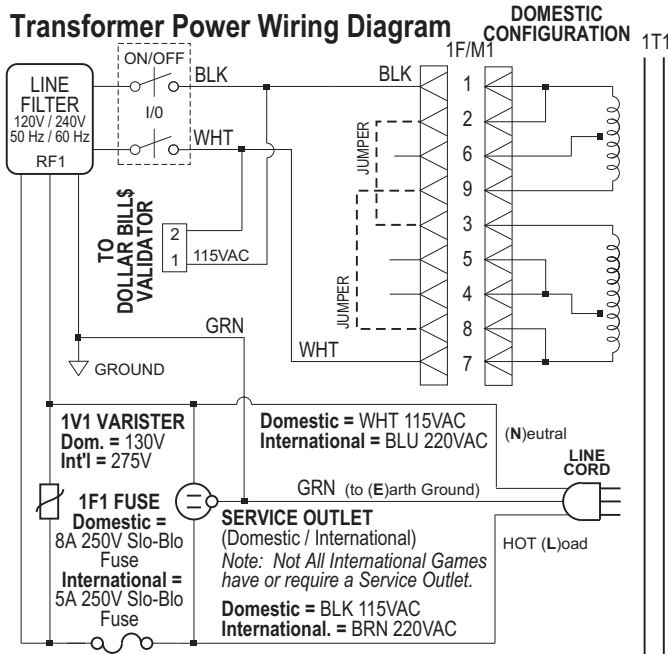

### ▼ Jumper Configurations for Voltage Variations ▼

N. AMERICA LINE VOLTAGE 110VAC / 120VAC

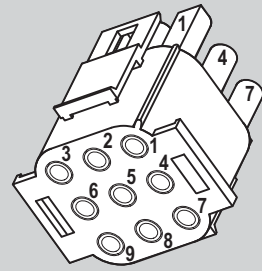
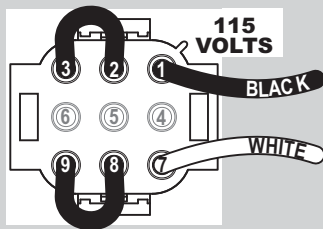

INTERNATIONAL or HIGH LINE VOLTAGE 230VAC / 218VAC / 206VAC

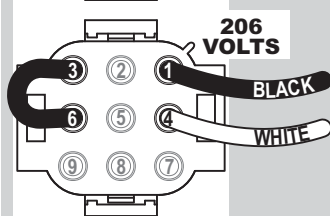
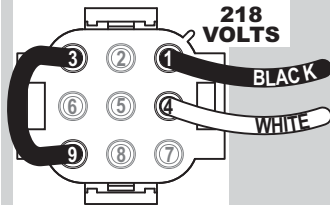
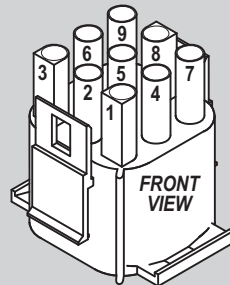
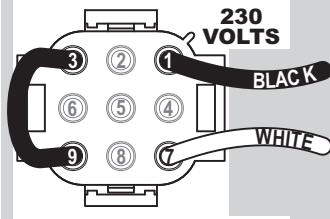

JAPAN or LOW LINE VOLTAGE 100VAC / 105VAC

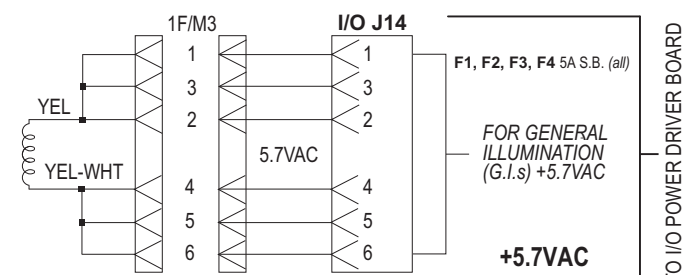
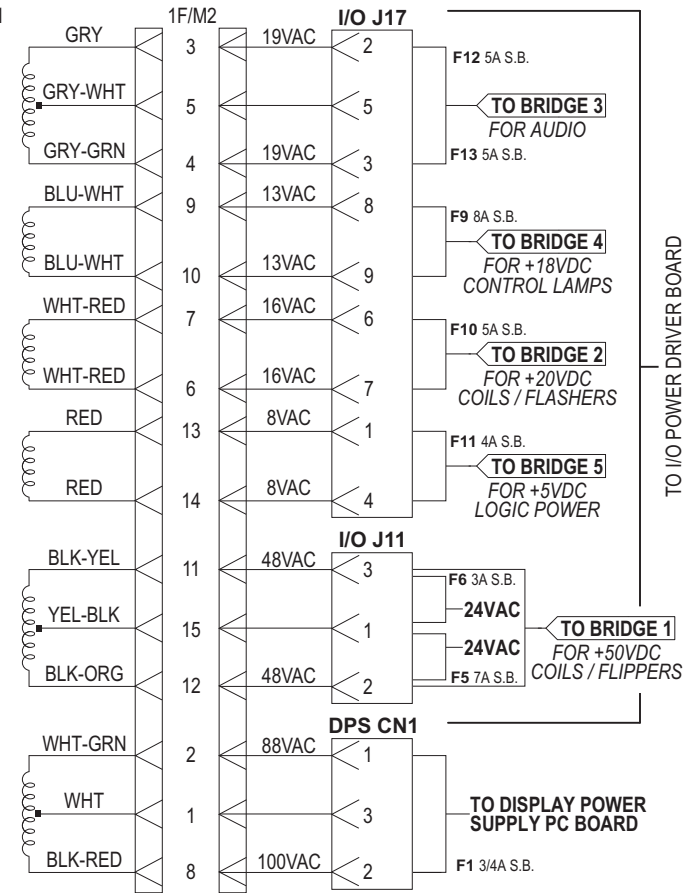
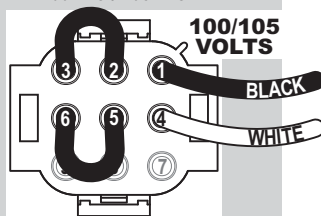

ALL FUSES RATED 250V SLO-BLO DO NOT OVERFUSE ▲

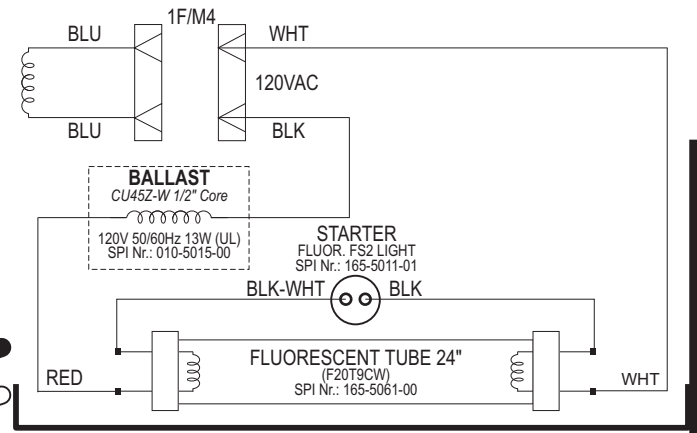

FLUORESCENT TUBE, STARTER & BALLAST LOCATED IN THE BACKBOX

Sec. 5: Cab. & Coin



# Cabinet Wiring Diagram

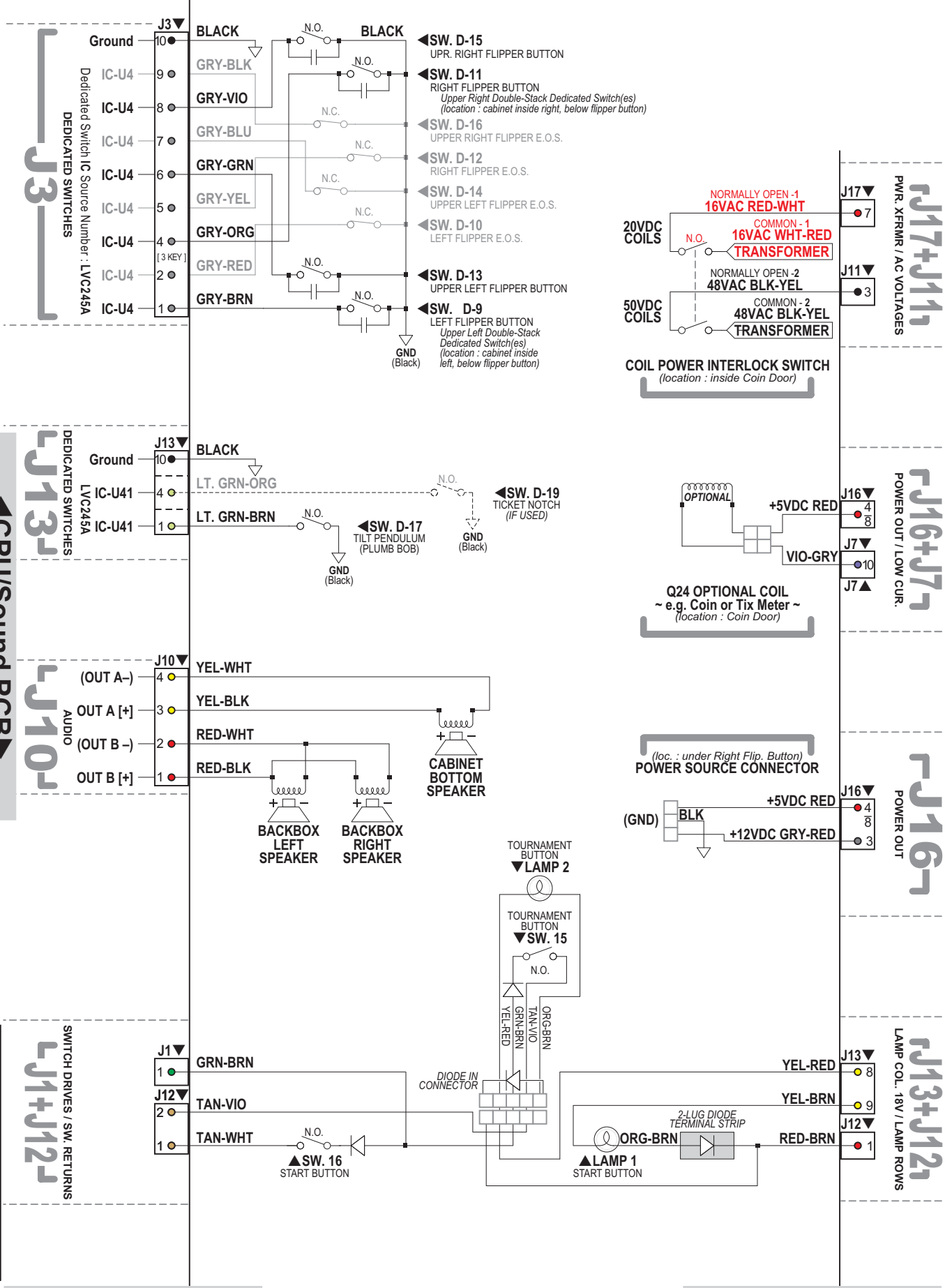

▲ CPU/Sound PCB ▲

▲ I/O POWER DRIVER PCB ▲



# Coin Door Wiring Diagram

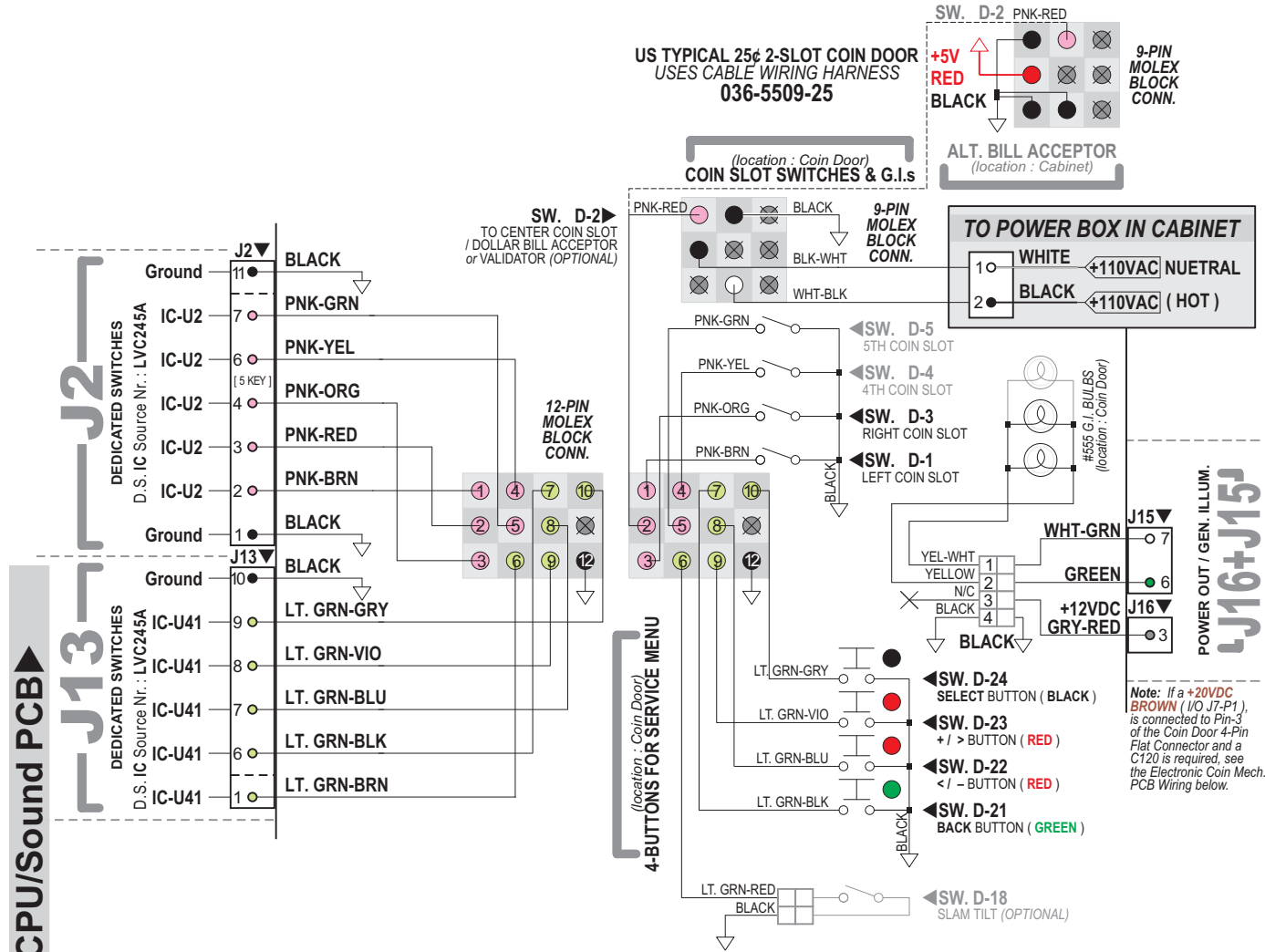

**1-SLOT COIN DOOR WITH C120 CAPABILITIES (NO INTERFACE COIN MECH PCB REQUIRED)**  
USES CABLE WIRING HARNESS  
**036-5509-31A (+12VDC GRY-RED)**

036-5509-31B (ICT/KAL ONLY) / 036-5509-31C (ODA ONLY) / 036-5509-31D (SPAIN ONLY)

**NON-US NON-C120 2-SLOT COIN DOOR**  
USES CABLE WIRING HARNESS  
**036-5509-32**

**NON-US NON-C120 3-SLOT COIN DOOR**  
USES CABLE WIRING HARNESS  
**036-5509-33**

**IF YOUR GAME HAS AN ELECTRONIC COIN MECH. INTERFACE PC BOARD ( 520-5193-00 ):**

**1-SLOT COIN DOOR USE WITH C120 CAPABILITIES REQUIRING PCB 520-5193-00**  
USES CABLE WIRING HARNESS  
**036-5509-31 (S.A.M. SYSTEM)**

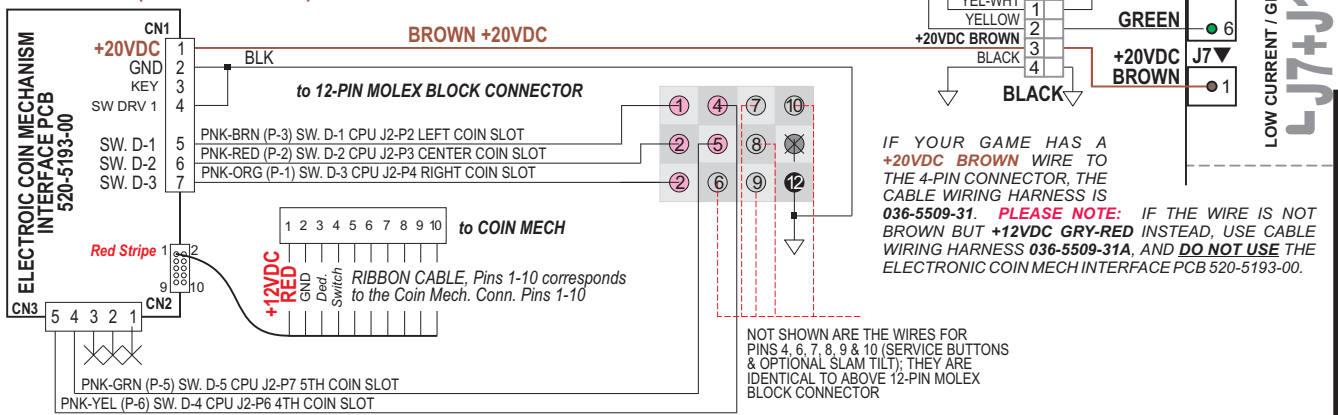



# Printed Circuit Boards (PCBs)

## Trough Up-Kicker Dual OPTO PCBs (515-0173-00 & 515-0174-00) Theory of Op. & Schematic

As light from the **Transmitter LED1** falls on the **Receiver LED1**, it generates a Positive Bias Voltage (0.7v to 1.5v) which is applied to the **Gate (G)** of **Q1 (Fet 2N5460)** turning **Q1** off. When **Q1** is held off, no current flows through **Q2's (2N3906) Base (B)**. With no *base current*, **Q2** is off and acts as an **OPEN SWITCH**. When the light is interrupted (**BLOCKED**) **R1 (Rec. Bd.)** bleeds the gate voltage off of **Q1** allowing it to conduct, switching **Q2** on, which acts as a **CLOSED SWITCH**. The **LED2 (Trans/Rec) Circuit** operates identical as the **LED1 Circuit**.

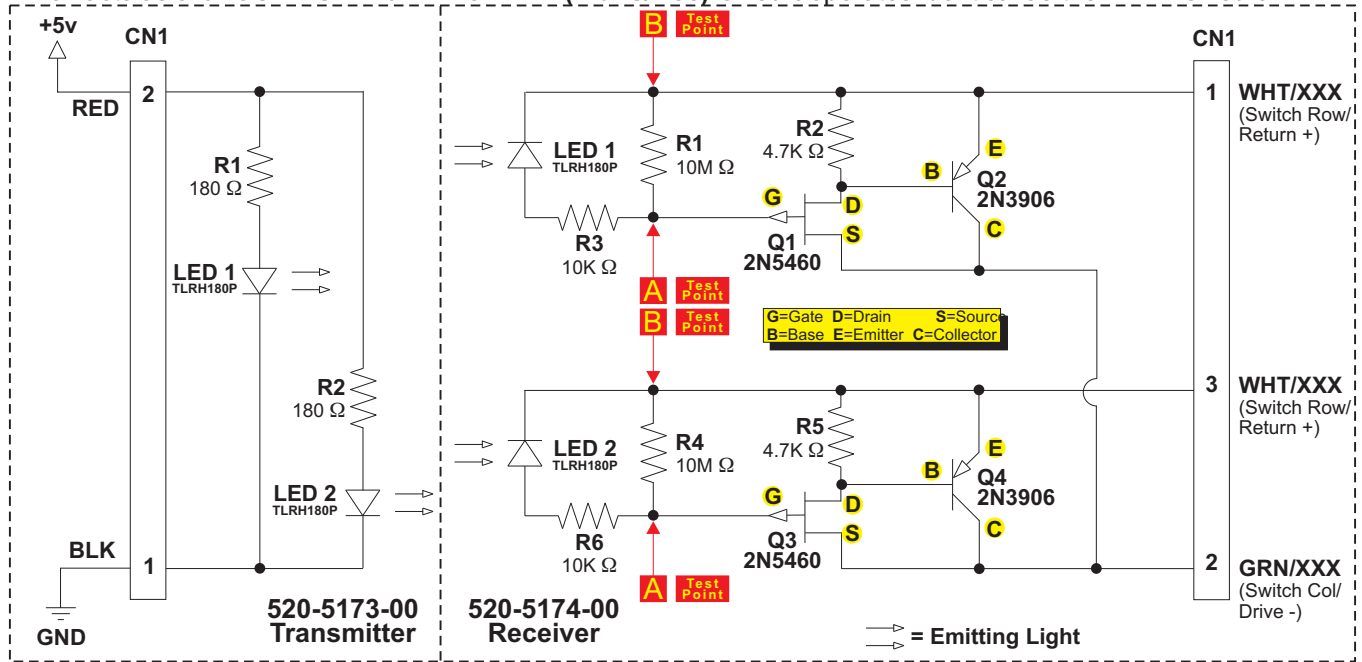

## Trough Up-Kicker Dual OPTO PCBs (515-0173-00 & 515-0174-00) Component Layout & Parts

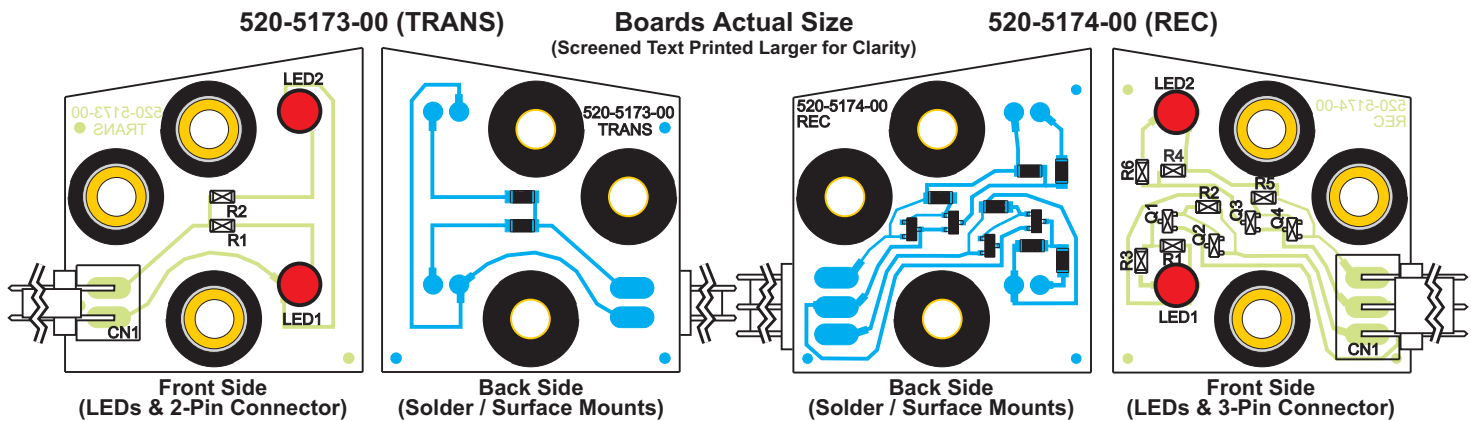

ITEM	QTY	PART NUMBER	REF-DESIGNATOR	DESCRIPTION
A+C & D	1	515-0173-00		Dual-OPTO Transmitter PCB Assembly (Item A PCB + Items C & D)
A	1	520-5173-00		Dual-OPTO Transmitter PCB
A-1	1	045-5111-02	CN1	(includes Items A-1 – A-3) 2X, .156" Rt. Angle (26-60-5020) Conn.
A-2	2	165-5052-00	LED1, LED2	LED TLRH180P (Ultra Bright Red)
A-3	2	121-5067-00	R1, R2	180 Ω Resistor SMT, 1/8W (CRCW)
B+C & D	1	515-0174-00		Dual-OPTO Receiver PCB Assembly (Item B PCB + Items C & D)
B	1	520-5174-00		Dual-OPTO Receiver PCB
B-1	1	045-5111-03	CN1	(includes Items B-1 – B-7) 3X, .156" Right Angle (26-60-5030) Conn.
B-2	2	165-5052-00	LED1, LED2	LED TLRH180P (Ultra Bright Red)
B-3	2	110-5006-00	Q1, Q3	2N5460, Transistor (P-FET SOT-23)
B-4	2	110-0086-00	Q2, Q4	2N3906, Transistor
B-5	2	121-5082-00	R1, R4	10M Ω Resistor SMT, 1/8W (CRCW)
B-6	2	121-5083-00	R2, R5	4.7K Ω Resistor SMT, 1/8W (CRCW)
B-7	2	121-5011-00	R3, R6	10K Ω Resistor SMT, 1/8W (CRCW)
C	3/per	530-5308-02		OPTO PCB Brass Tube Spacer
D	3/per	545-5518-00		OPTO PCB Rubber Grommet

Replacement Part:  
**LED TLRH180P**  
 (T1-3/4 GaAIAs)  
 SPI Part N<sup>o</sup>:  
**165-5052-00**

Sec. 5: PCBs



# OPTO Troubleshooting

## 1. Volt Meter Test (indicates normal operating condition):

A. **OPEN OPTO** (Light Falling on LED) = *SWITCH OPEN*. Place meter leads across points **A** and **B** on the **LED1 Circuit** (Refer to Schematic Drawing on previous page, 520-5174-00 Receiver Side). It should read approximately 0.8 - 1.2v DC. The **LED2 Circuit** operates the same.

B. **CLOSED OPTO** (Light Blocked) = *SWITCH CLOSED*. Place meter leads across points **A** and **B** on the **LED1 Circuit** (Refer to Schematic Drawing on previous page, 520-5174-00 Receiver Side). It should read approximately 0.0 - 0.1v DC. The **LED2 Circuit** operates the same.

## 2. Oscilloscope Test (indicates normal operating condition):

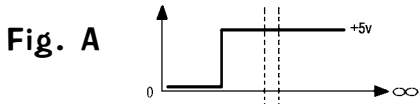

A. **OPEN OPTO** (Light Falling on LED) = *SWITCH OPEN*. Place Scope lead at **Pin-1** of OPTO Rec. Board with Scope Grounded (see Schematic). The Scope should display a **STEADY +5v** as shown in **Fig. A**, Wave Form Diagram.

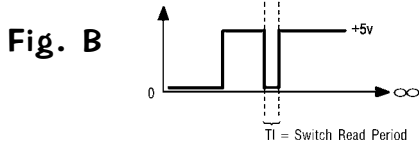

B. **CLOSED OPTO** (Light Blocked) = *SWITCH CLOSED*. Place Scope lead at **Pin-1** of OPTO Rec. Board with Scope Grounded (see Schematic). The Scope should display a **PULSE STREAM** indicating **Q2** has switched "On" as shown in **Fig. B**, Wave Form Diagram. This is your Switch Drive Pulse.

## 3. Bench Test (See Fig. C):

Please Note: To perform this test you must use a spare 560Ω Pull-Up Resistor, SPI N<sup>o</sup>: 121-5047-00

Disconnect the **OPTO Transmitter / Receiver Board** from the circuit. Connect one side of a 560Ω Pull-Up Resistor to **Pin-1** of the OPTO Receiver Bd. and the other side of the resistor to a 5v DC source. Connect **Pin-2** to GND. Connect a +5v DC source to **Pin-1** of the Transmitter & GND to **Pin-2**. Align with the Receiver OPTO approx. 3" distance. Using your Volt-Meter or an Oscilloscope, monitor **Pin-1** while **BLOCKING** and **UNBLOCKING** the **BEAM** from the Trans. The output will be approx. +5v DC when the **BEAM IS NOT BLOCKED** and approx. 0v when the **BEAM IS BLOCKED**.

Fig. C

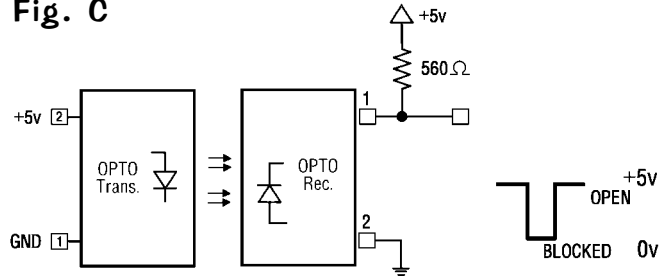

## Trough Dual OPTO Boards Alignment / Test for LED1

When a working **OPTO** is installed and connected in a game, the transmitter should light (**LED1 lower & LED2 upper**) when the power is switched on. With the playfield in **Service Position #1** (playfield lifted up in the half-way position resting on the Prop Rod or edge slide support brackets) and the game on, the LED lights should show up as a **BRIGHT RED RINGS** through the back of the Receiver Board around the **Receivers LED1 & LED2** (see **Fig. 1**). Testing only **LED1**: With the game in **Switch Test Mode**, lifting the Trough Plunger with a fingertip should block the **BEAM** and cause the Switch Position to trigger (see **Fig. 2**). View **Fig. 2a & 2b** (on the next page) for a sectional view of the Light Path (note alignment) and what happens as a ball breaks the light beam.

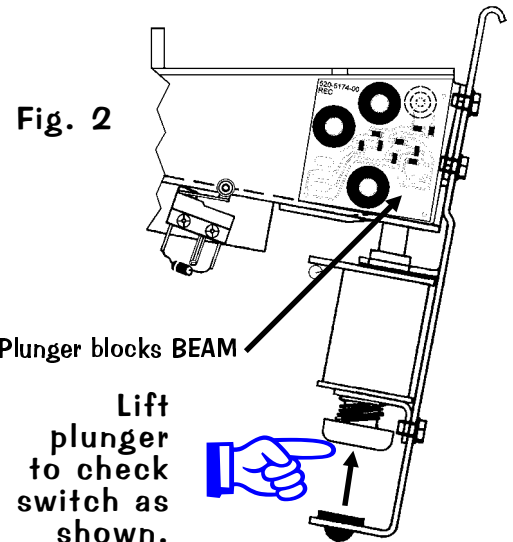
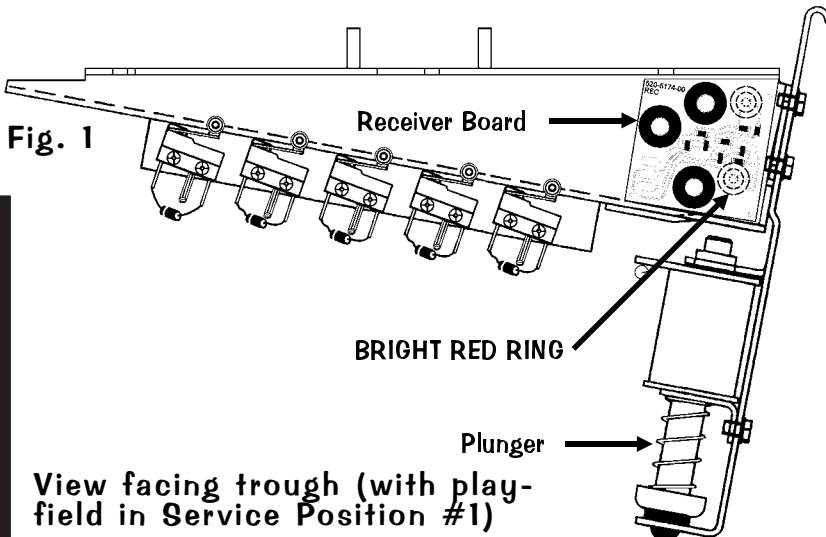

Sec. 5: PCBs

View facing trough (with playfield in Service Position #1)



## Sectional view from right (Fig. 2a & 2b)

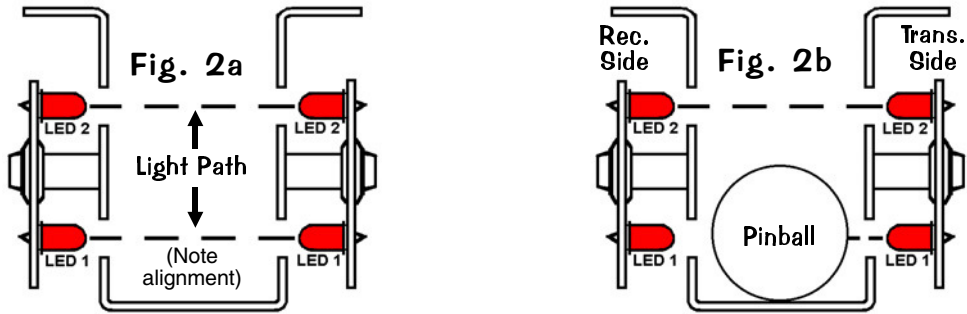

### Trough Dual OPTO Boards Alignment / Test for LED2

When a working **OPTO** is installed and connected in a game, the transmitter should light (**LED1 lower & LED2 upper**) when the power is switched on. With the playfield in **Service Position #1** (playfield lifted up and resting on the Playfield Support Slide Brackets) and the game on, the LED lights should show up as a **BRIGHT RED RINGS** through the back of the Receiver Board around the **Receivers LED1 & LED2** (see Fig. 1, previous page). Testing only **LED2**: **TO PERFORM THIS TEST, A PINBALL MUST BE IN THE BALL TROUGH.** With the game in **Switch Test Mode**, lifting the Trough Plunger with a finger tip should block the **BEAM** on LED2 and cause the Switch Position to trigger (see Fig. 3). View Fig. 3a & 3b for a sectional view of the Light Path (note alignment) and what happens as a "double-stacked" ball scenario breaks the light beam.

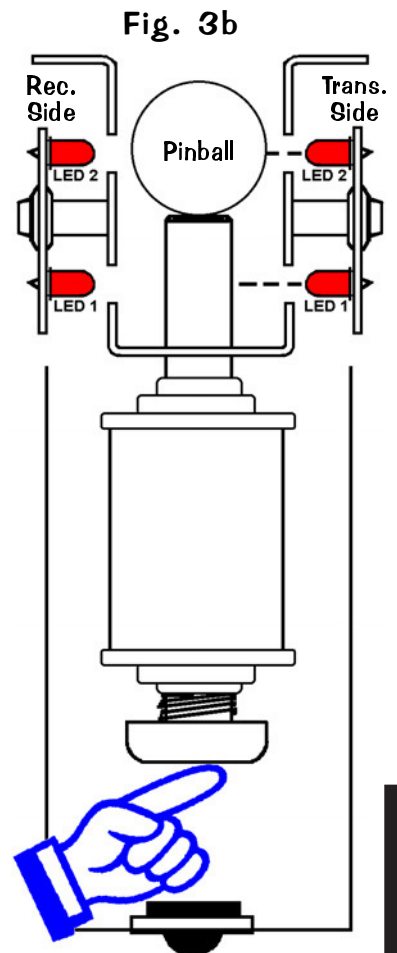
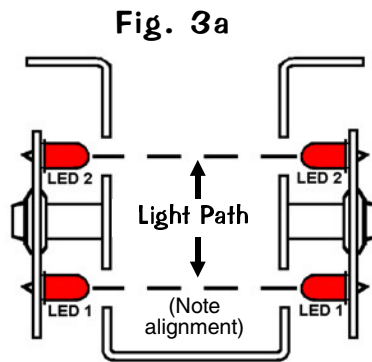
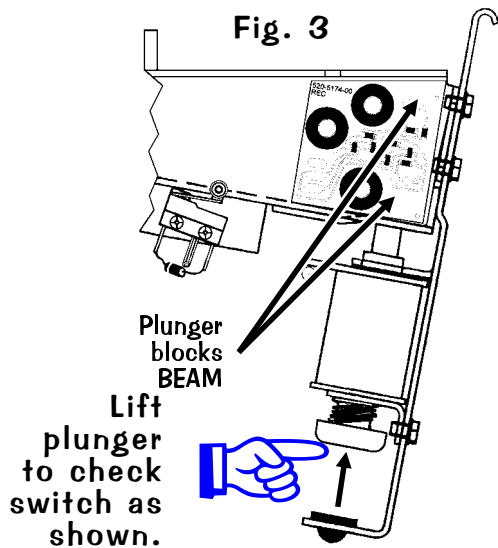

## I M P O R T A N T

If replacement of **LED** is required, insure that is **mounted correctly before and after soldering** (See Fig. 4a / 4b).

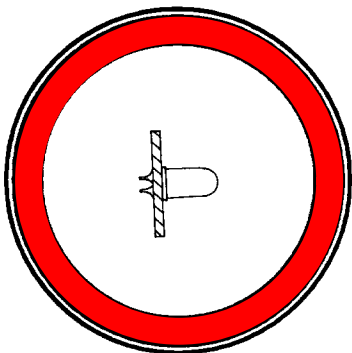

Fig. 4a  
Correct Position

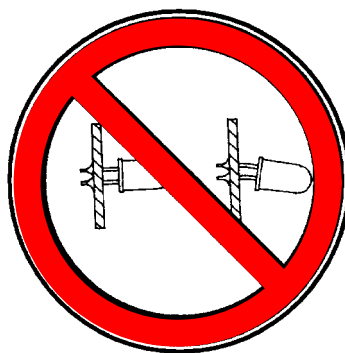
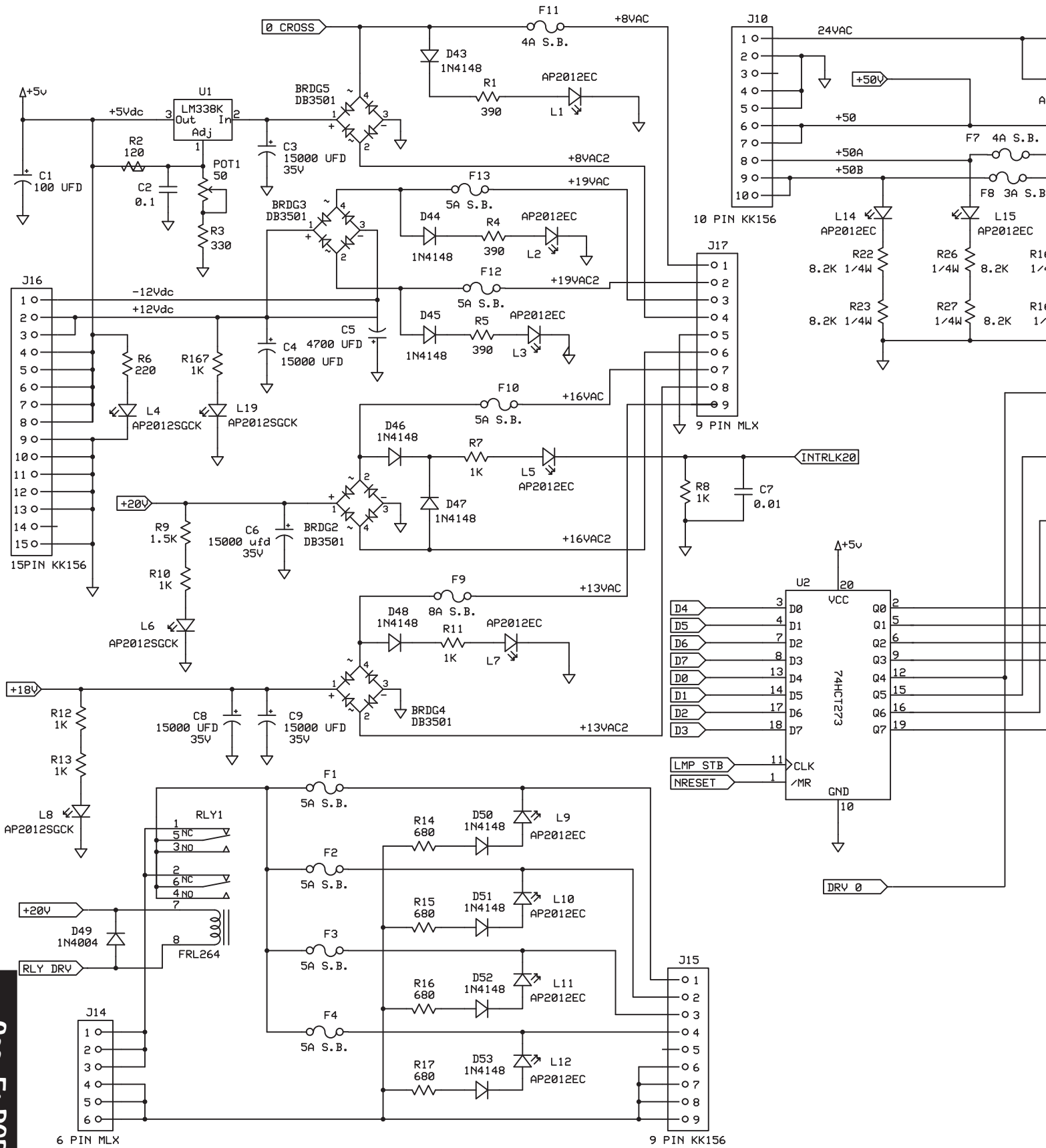

Fig. 4b  
Incorrect Position

I/O POWER DRIVER PCB S.A.M. System (520-5249-00) Schematic (Sheet 1 of 4)



Sec. 5: PCBs





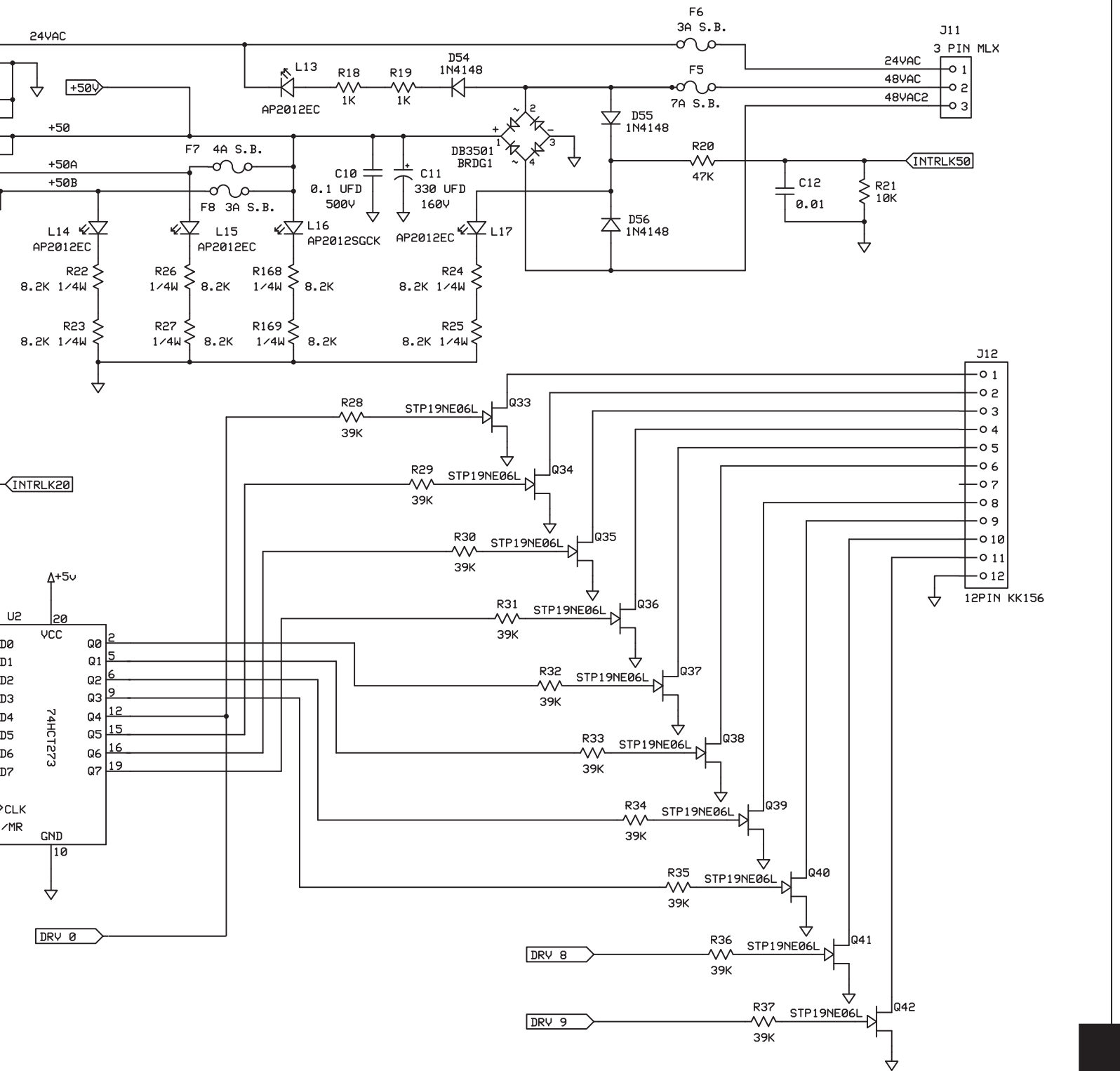

<b>STERN PINBALL, INC.</b>		
<b>I/O POWER DRIVER BOARD</b>		
520-5249-00	Rev A 5/20/2005	Page 1 of 4

**Sec. 5: PCBs**



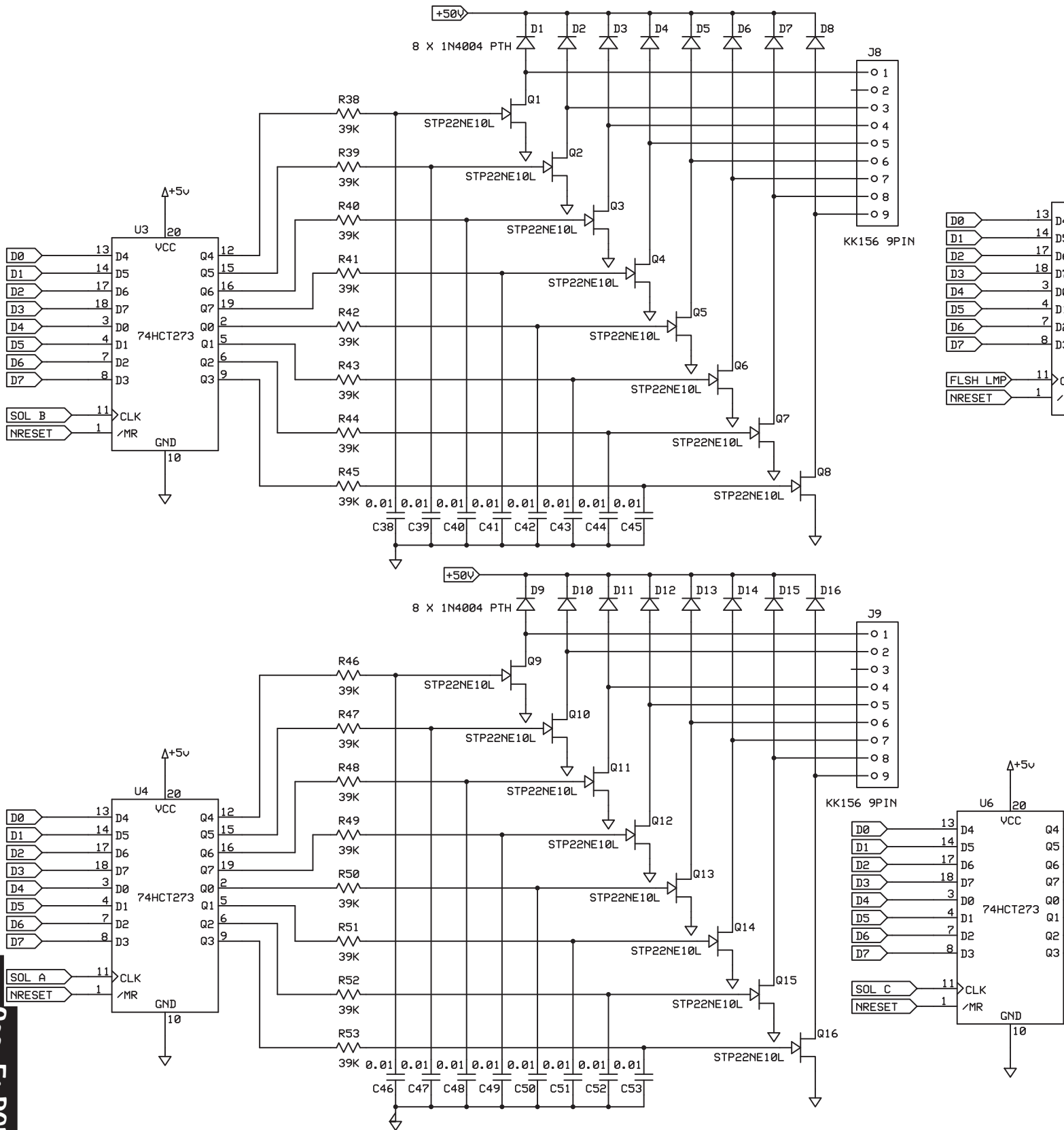

Sec. 5: PCBs



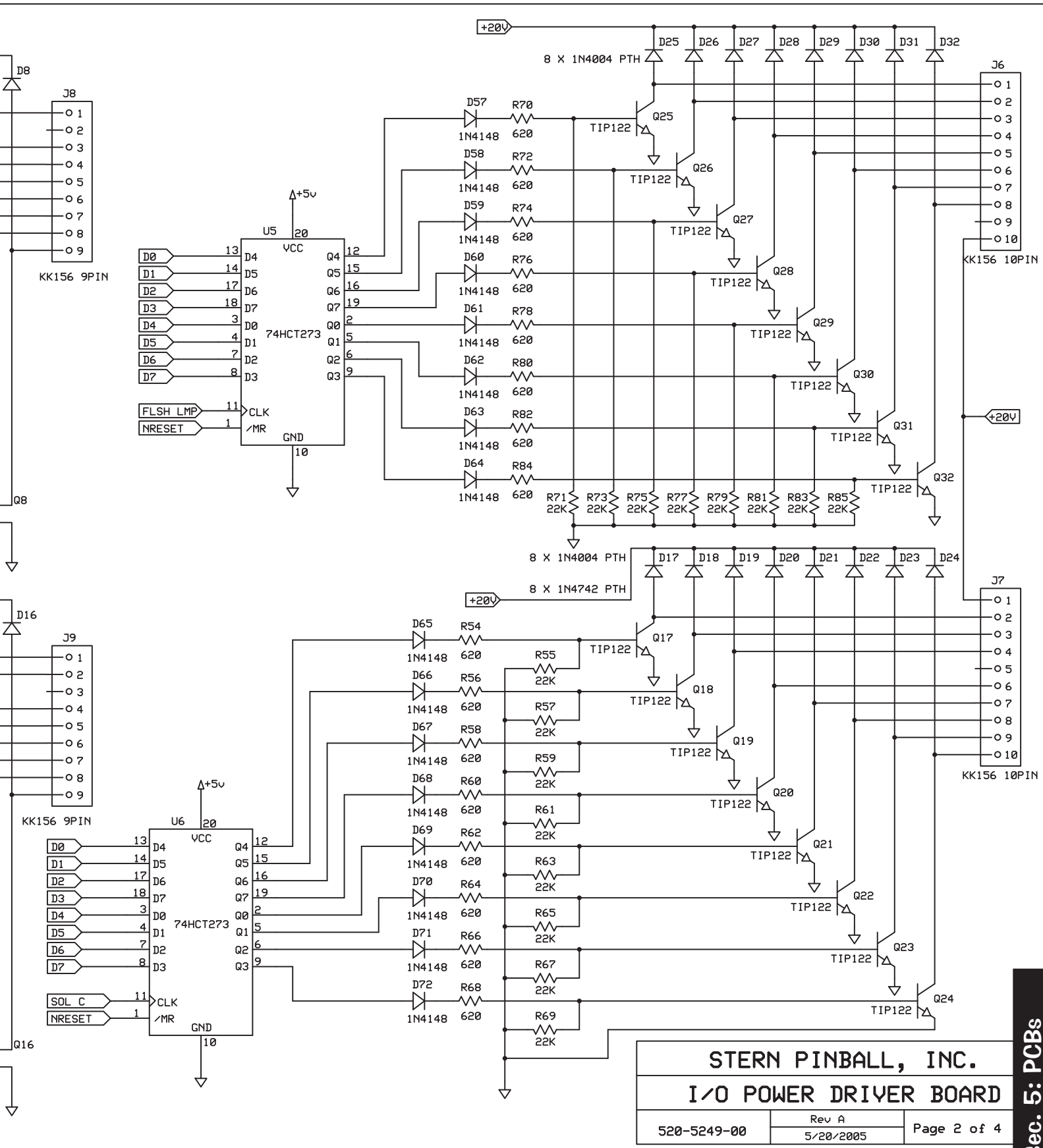

**STERN PINBALL, INC.**

**I/O POWER DRIVER BOARD**

520-5249-00	Rev A 5/20/2005	Page 2 of 4
-------------	--------------------	-------------

**Sec. 5: PCBs**



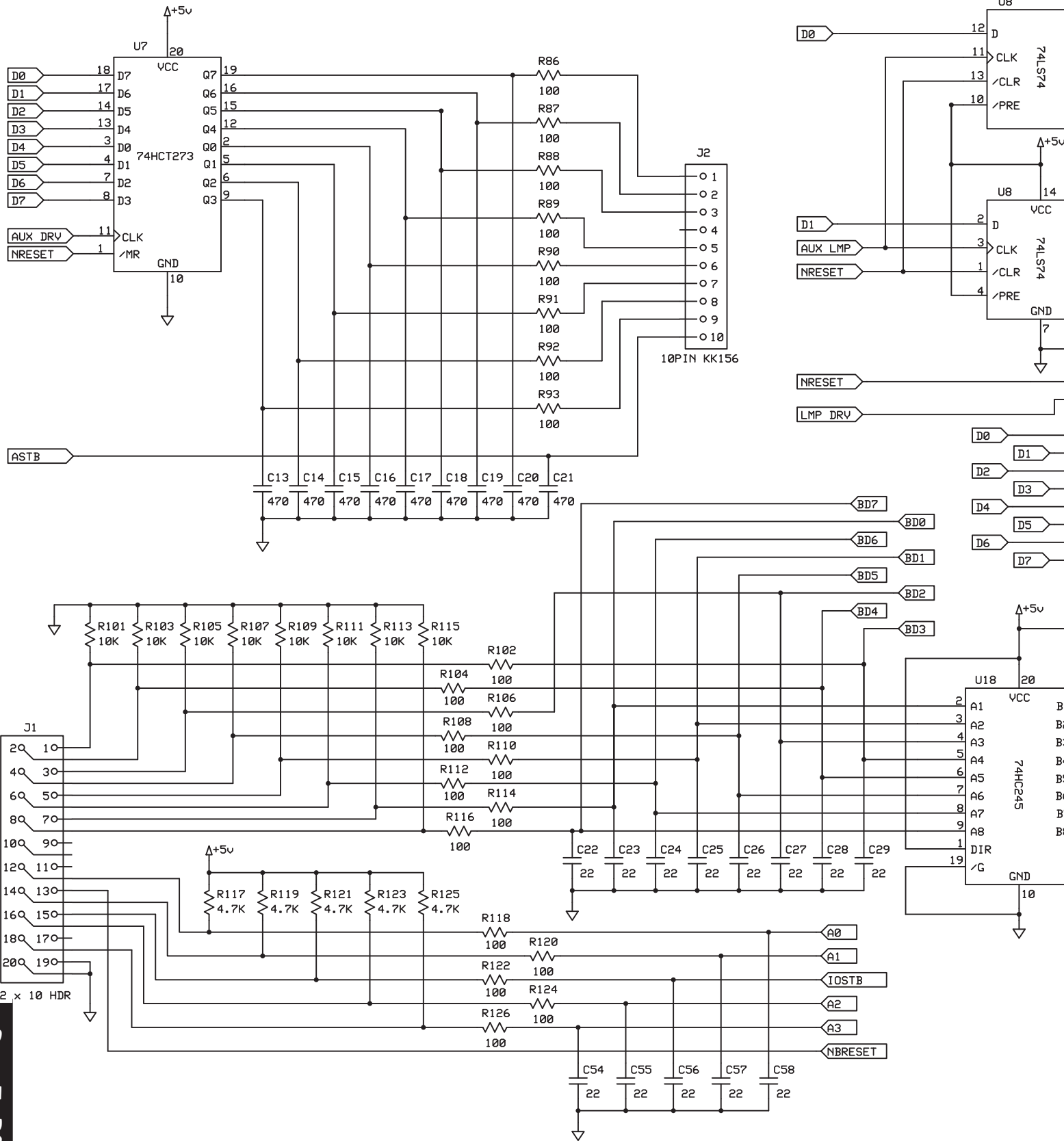

Sec. 5: PCBs



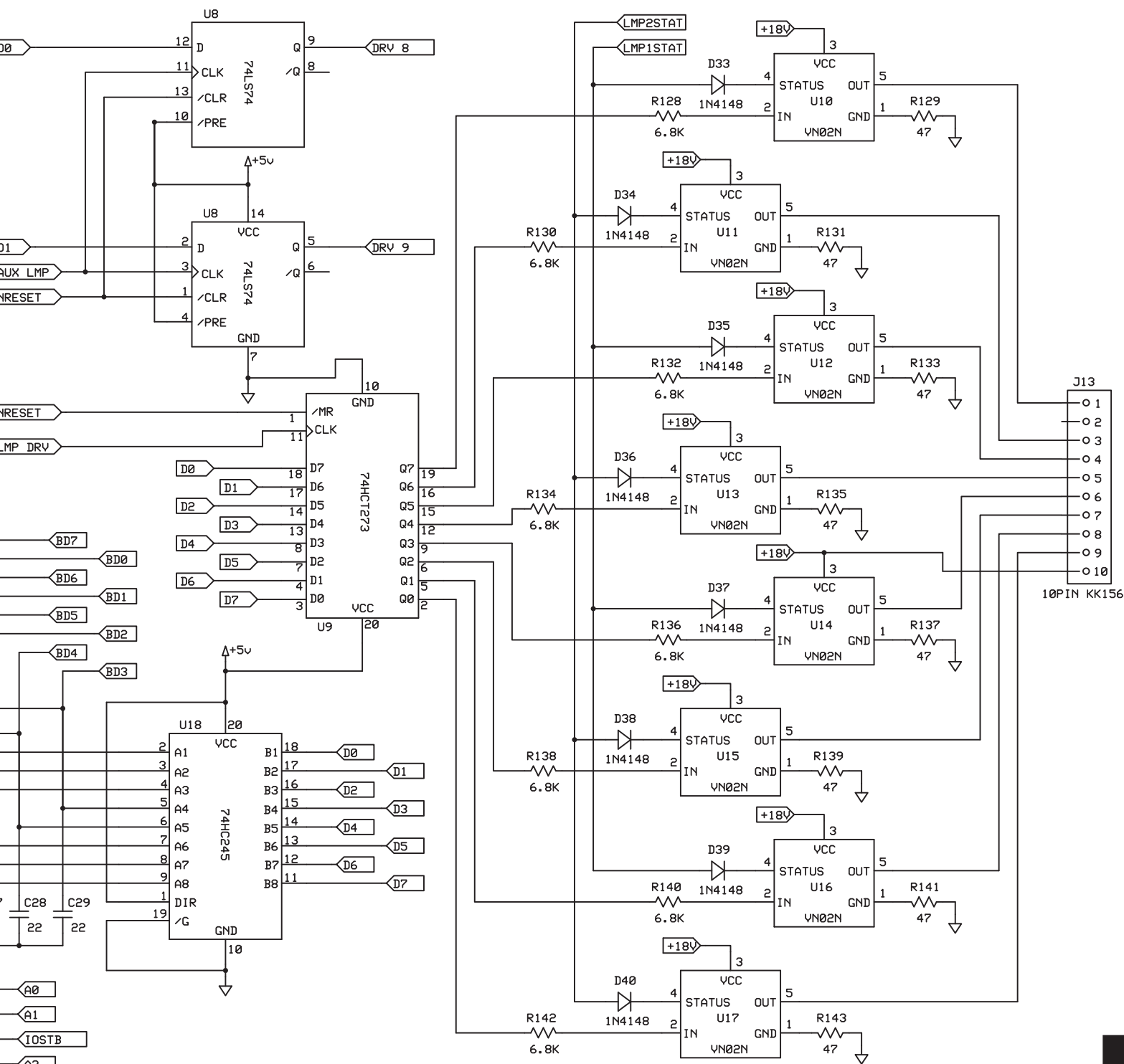

<b>STERN PINBALL, INC.</b>		
<b>I/O POWER DRIVER BOARD</b>		
520-5249-00	Rev A 5/20/2005	Page 3 of 4

**Sec. 5: PCBs**



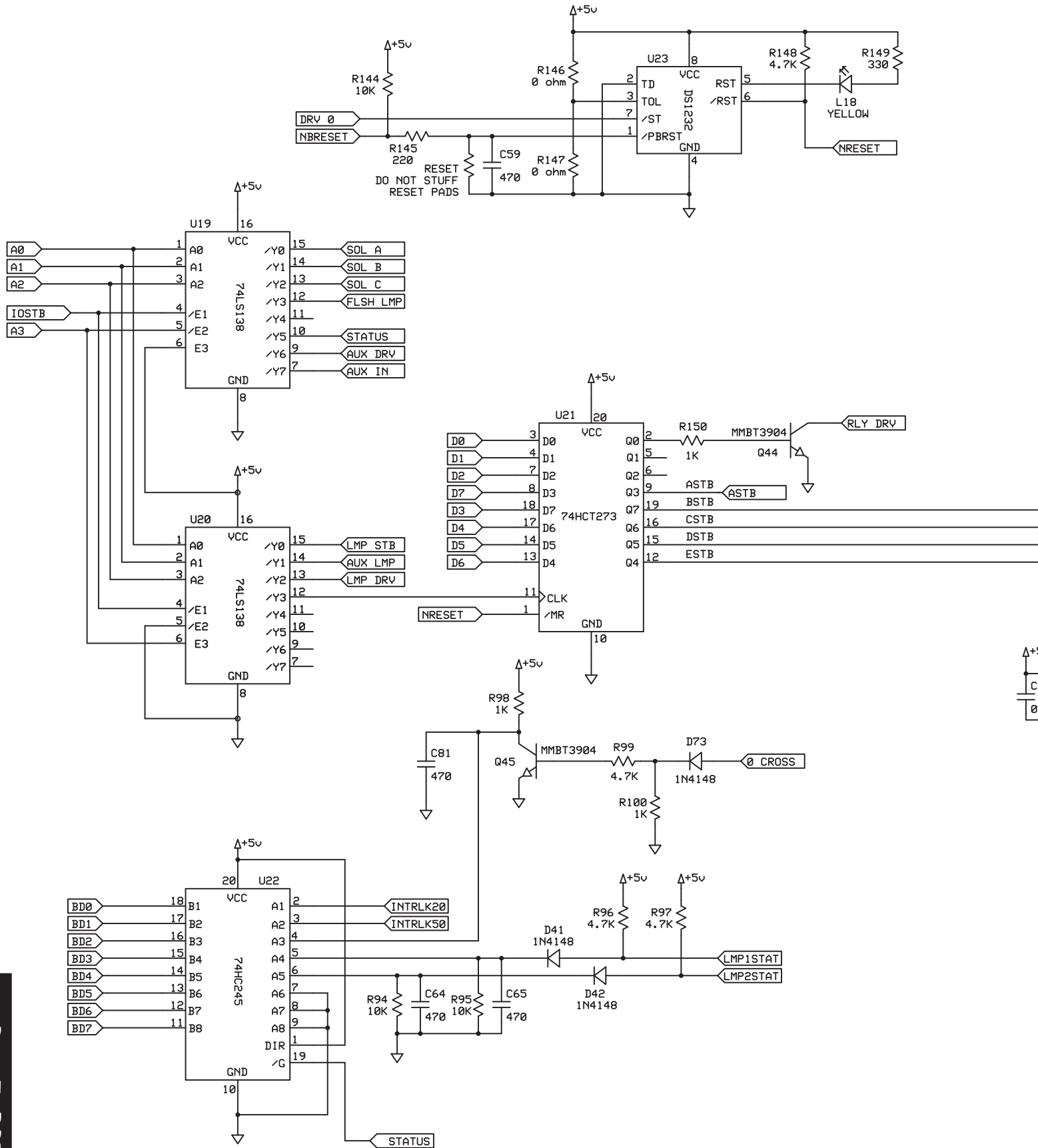

Sec. 5: PCBs



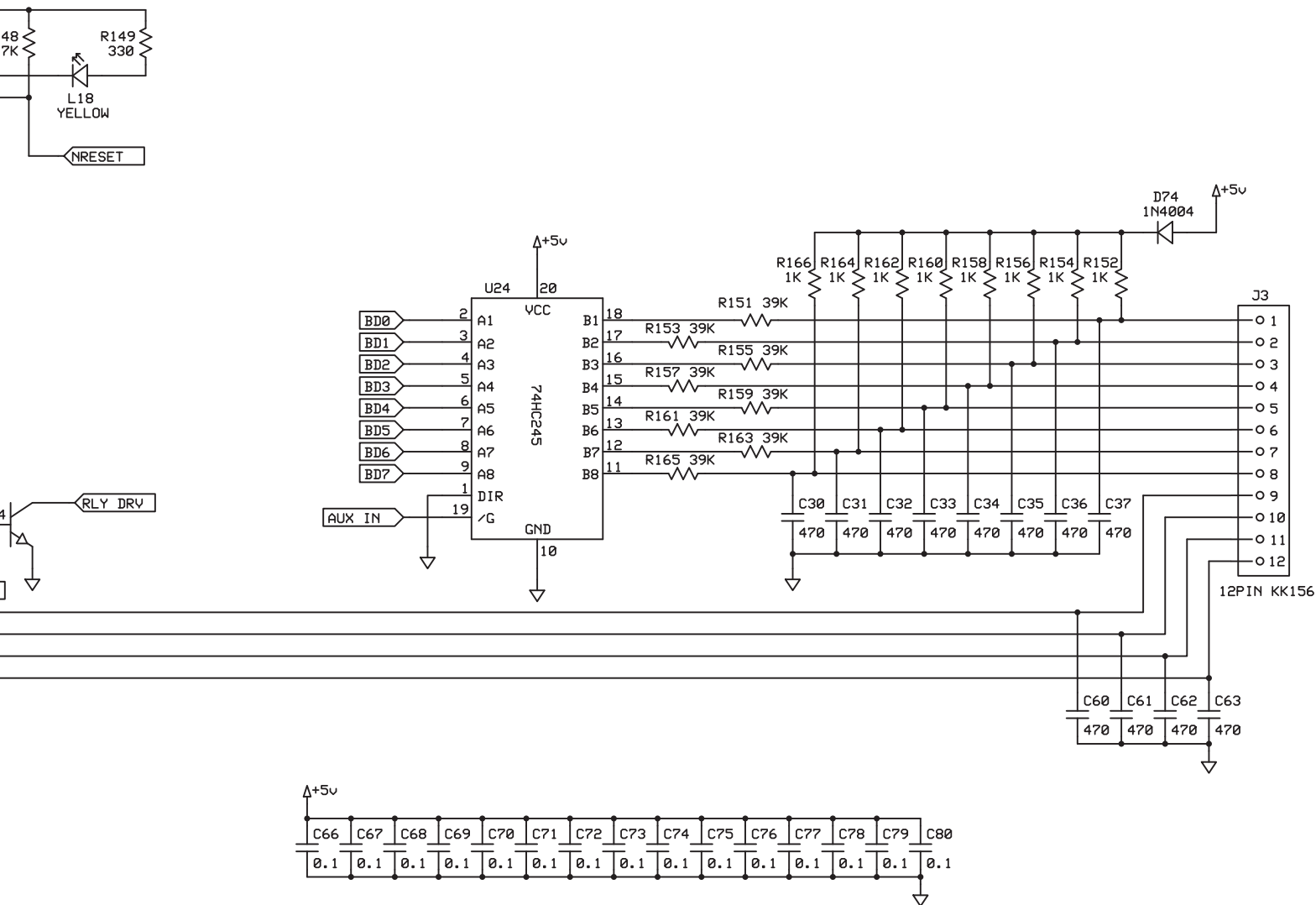

SS

<b>STERN PINBALL, INC.</b>		
<b>I/O POWER DRIVER BOARD</b>		
520-5249-00	Rev A 5/20/2005	Page 4 of 4

**Sec. 5: PCBs**



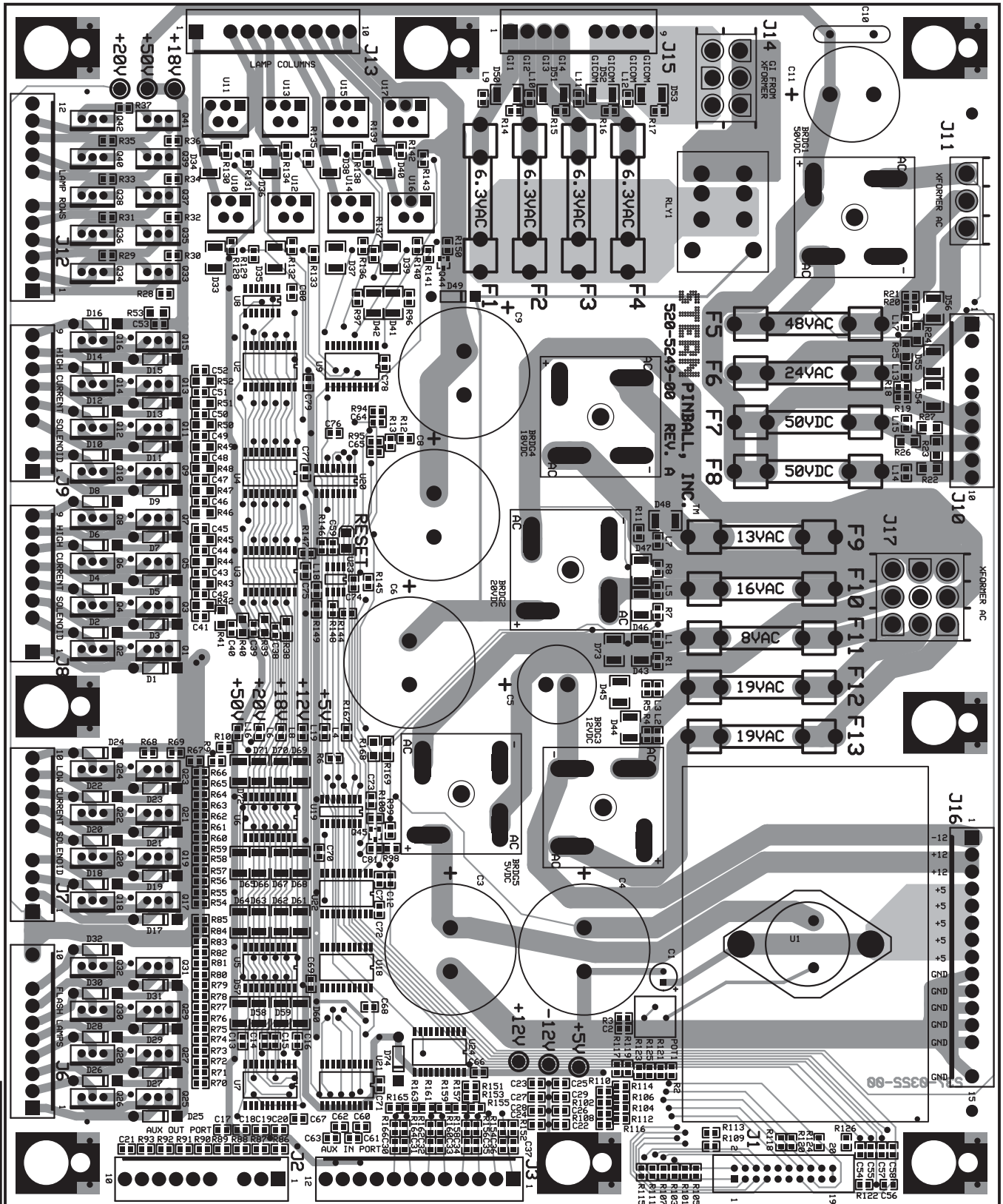

Sec. 5: PCBs





# I/O POWER DRIVER PCB S.A.M. System (520-5249-00) Parts

ITEM	QTY.	SPI PART NUMBER	(MFG. P.N.)	REF-DESIGNATOR	DESCRIPTION (SM = Surface Mount)
—	1	520-5249-00		I/O Power Driver PCB (S.A.M. System), Rev. A	(includes Items 1-67)
1	1	121-6001-00	(101-0001807)	R9	Resistor SM 0805 Film 1.5KΩ 1/10W 5%
2	22	121-6002-00	(101-0001820)	R86, R87, R88, R89, R90, R91, R92, R93, R102, R104, R106, R108, R110, R112, R114, R116, R118, R120, R122, R124, R126, R146, R21, R94, R95, R101, R103, R105, R107, R109, R111, R113, R115, R144	Resistor SM 0805 Film 100Ω 1/10W 5%
3	12	121-6020-00	(101-0001827)	R2	Resistor SM 0805 Film 10KΩ 1/10W 5%
4	1	121-6003-00	(101-0001845)	R7, R8, R10, R11, R12, R13, R18, R19, R98, R100, R150, R152, R154, R156, R158, R160, R162, R164, R166, R167	Resistor SM 0805 Film 120Ω 1/10W 5%
5	20	121-6022-00	(101-0001905)	R6, R145	Resistor SM 0805 Film 1KΩ 1/10W 5%
6	2	121-6004-00	(101-0001943)	R55, R57, R59, R61, R63, R65, R67, R69, R71, R73, R75, R77, R79, R81, R83, R85	Resistor SM 0805 Film 220Ω 1/10W 5%
7	16	121-6005-00	(101-0001849)	R3, R149	Resistor SM 0805 Film 22KΩ 1/10W 5%
8	2	121-6006-00	(101-0002012)	R1, R4, R5	Resistor SM 0805 Film 330Ω 1/10W 5%
9	3	121-6007-00	(101-0002031)	R151, R153, R155, R157, R159, R161, R163, R165	Resistor SM 0805 Film 390Ω 1/10W 5%
10	8	121-6013-00	(101-0002035)	R96, R97, R99, R117, R119, R121, R123, R125, R148	Resistor SM 0805 Film 39KΩ 1/10W 5%
11	9	121-6008-00	(101-0002046)	R129, R131, R133, R135, R137, R139, R141, R143	Resistor SM 0805 Film 4.7KΩ 1/10W 5%
12	8	121-6014-00	(101-0002065)	R20	Resistor SM 0805 Film 47Ω 1/10W 5%
13	1	121-6015-00	(101-0002071)	R128, R130, R132, R134, R136, R138, R140, R142	Resistor SM 0805 Film 47KΩ 1/10W 5%
14	8	121-6009-00	(101-0002108)	R54, R56, R58, R60, R62, R64, R66, R68, R70, R72, R74, R76, R78, R80, R82, R84	Resistor SM 0805 Film 6.8KΩ 1/10W 5%
15	16	121-6010-00	(101-0002116)	R14, R15, R16, R17	Resistor SM 0805 Film 620Ω 1/10W 5%
16	4	121-6016-00	(101-0002126)	R28, R29, R30, R31, R32, R33, R34, R35, R36, R37	Resistor SM 0805 Film 680Ω 1/10W 5%
17	10	121-6011-00	(101-0002296)	R22, R23, R24, R25, R26, R27, R168, R169	Resistor SM 1206 Film 22KΩ 1/10W 5%
18	8	121-6012-00	(101-0002473)	R38, R39, R40, R41, R42, R43, R44, R45, R46, R47, R48, R49, R50, R51, R52, R53	Resistor SM 1206 Film 8.2KΩ 1/10W 5%
19	16	121-6013-01	(101-0002378)	C2, C66, C67, C68, C69, C70, C71, C72, C73, C74, C75, C76, C77, C78, C79, C80	Resistor SM 1206 Film 39KΩ 1/10W 5%
20	16	125-6001-00	(121-0000056)	C13, C14, C15, C16, C17, C18, C19, C20, C21, C30, C31, C32, C33, C34, C35, C36, C37, C59, C60, C61, C62, C63, C64, C65, C81	Capacitor SM 0805 Cer. .1uF 50V 10% X7R
21	25	125-6002-00	(121-0000096)	C7, C12, C38, C39, C40, C41, C42, C43, C44, C45, C46, C47, C48, C49, C50, C51, C52, C53, C22, C23, C24, C25, C26, C27, C28, C29, C54, C55, C56, C57, C58	Capacitor SM 0805 Cer. 470PF 50V 5% NPO
22	18	125-6003-00	(121-0004236)	C1	Capacitor SM 0805 Cer. .01uF 50V 10% X7R
23	13	125-6004-00	(121-0005318)	C5	Capacitor SM 0805 Cer. 22PF 100V 5% NPO
24	1	125-5032-00	(131-0003773)	C10	Capacitor Tht. Radial Alum. 100uF 25V 20%
25	1	125-5034-00	(131-0003864)	C11	Capacitor Tht. Radial Alum. 4700uF 35V 20%
26	1	125-5029-01	(133-0003741)	C3, C4, C6, C8, C9	Capacitor Tht. Disc Cer. .1uF 500V 20%
27	1	125-6022-00	(134-0003846)	D1, D2, D3, D4, D5, D6, D7, D8, D9, D10, D11, D12, D13, D14, D15, D16, D17, D18, D19, D20, D21, D22, D23, D24, D25, D26, D27, D28, D29, D30, D31, D32, D49, D74	Capacitor Tht. Radial Alum. 330uF 160V 20%
28	5	125-5036-01	(134-0004000)	BRDG1, BRDG2, BRDG3, BRDG4, BRDG5	Cap. Tht. Rad. Al. 15000uF 35V 20% Snap-In
29	34	112-6001-01	(183-0004374)	Q1, Q2, Q3, Q4, Q5, Q6, Q7, Q8, Q9, Q10, Q11, Q12, Q13, Q14, Q15, Q16	Diode Tht. DO-41 1N4004 400V 1A
30	5	112-5000-00	(187-0004700)	Q33, Q34, Q35, Q36, Q37, Q38, Q39, Q40, Q41, Q42	Bridge Tht. Fullwave 100V 35A MB-35
31	10	110-0088-01	(203-0003591)	Q17, Q18, Q19, Q20, Q21, Q22, Q23, Q24, Q25, Q26, Q27, Q28, Q29, Q30, Q31, Q32	Fet Tht. TO-220 STP20NE06L NFet 60V 20A
32	16	110-0106-00	(203-0003592)	U18, U22, U24	Fet Tht. TO-220 20N10L NFet 100V 20A
33	8	110-0089-00	(203-0003597)	U10, U11, U12, U13, U14, U15, U16, U17	Fet Tht. PENTAWAT VN02N NFet HighSide 26V 6A
34	2	110-0069-01	(211-0003589)	Q44, Q45	Trans. SM SOT-23 MMST3904 NPN 40V 0.2A
35	16	110-0067-00	(213-0003565)	U8	Transistor Tht. TO-220 TIP122 NPN 100V 5A
36	3	100-6003-00	(221-0000972)	U1	I.C. SM SOIC 74HC245 Oct. Bus. Xcvr.
37	1	100-6000-00	(221-0011253)	U2	I.C. SM SOIC DS1832S, SO-8
38	8	100-5056-00	(221-0001287)	U2, U3, U4, U5, U6, U7, U9, U21	I.C. SM SOIC 74HCT273 Oct. D F-F
39	2	100-6001-00	(221-0003728)	U19, U20	I.C. SM SO 74LS138D Hex Inverter; 3-8 DC/DMX
40	1	100-6002-00	(221-0011135)	U8	I.C. SM SOIC 74LS74AD SOIC-14
41	1	100-0356-00	(225-0003582)	U1	I.C. Tht. TO-3 LM338 5A Adjust. Voltage Reg.
42	5	045-	(315-0003427)	J2, J6, J7, J10, J13	Con. Tht. Hdr. 10 Pin, 1 Row .156"
43	1	045-	(315-0006910)	J1	Con. Tht. Hdr. 20 Pin, 2 Row .1"
44	2	045-	(315-0003430)	J3, J12	Con. Tht. Hdr. 12 Pin, 1 Row .156"
45	1	045-	(315-0003432)	J16	Con. Tht. Hdr. 15 Pin, 1 Row .156"
46	1	045-	(315-0003503)	J11	Con. Tht. Pwr. 3 Pin, 1 Row .25"
47	1	045-	(315-0003504)	J14	Con. Tht. Pwr. 6 Pin, 2 Row .25"
48	1	045-	(315-0003505)	J17	Con. Tht. Pwr. 9 Pin, 3 Row .25"
49	3	045-	(315-0003821)	J8, J9, J15	Con. Tht. Hdr. 9 Pin, 1 Row .156"
50	2	200-5000-08	(407-0003117)	F6, F8	Fuse 3 Amp 250V Slo-Blo (Glass, Tht. 3AG)
51	2	200-5000-06	(407-0003118)	F7, F11	Fuse 4 Amp 250V Slo-Blo (Glass, Tht. 3AG)
52	7	200-5000-01	(407-0003119)	F1, F2, F3, F4, F10, F12, F13	Fuse 5 Amp 250V Slo-Blo (Glass, Tht. 3AG)
53	1	200-5000-03	(407-0003121)	F5	Fuse 7 Amp 250V Slo-Blo (Glass, Tht. 3AG)
54	1	200-5000-05	(407-0003122)	F9	Fuse 8 Amp 250V Slo-Blo (Glass, Tht. 3AG)
55	1	121-5039-00	(415-0004788)	POT1	Potentiometer THT 50Ω Single Top Adjust. Trimr.
56	1	165-6000-00	(425-0006913)	L18	LED SM Yellow 0805 LED
57	5	165-6001-00	(425-0007753)	L4, L6, L8, L16, L19	LED SM Green Ultrabright Top
58	13	165-6002-00	(425-0007755)	L1, L2, L3, L5, L7, L9, L10, L11, L12, L15, L17	LED SM Red Ultrabright Top 0805 LED
59	1	190-5002-00	(448-0004778)	RLY1	Relay Tht. GW DPDT10A DC24 2400VA PC MNT
60	1	127-5001-00	(461-0003520)	for BRDG 4, BRDG 5	Heatsink, Sq. Finned Ba TO-220 Avid 531102
61	1	127-5001-02	(461-0003534)	for U1	Heatsink All Large Finned Alum. TO-3
62	1	127-5001-04	(579103B00000G)	for U1 on TO-3 LM338 5A Adj. Volt. Reg.	Heatsink, Circular Finned (Mfg. Aavid)
63	4	240-5008-00	(503-0004469)	2 pcs. for U1, 1 pc. each for BRDG 4 & 5	#6-32 Keps Nut
64	26	205-0004-00	(503-0004667)	2 pcs. each for F1 - F13	Fuseclip with End Stops (+ Ears)
65	4	237-5504-00	(504-0004610)	2 pcs. for U1, 1 pc. each for BRDG 4 & 5	#6-32 X 3/4" PPH MS (Zinc) Screw
66	2	254-5007-02	(507-0004544)	for BRDG 4 & 5 (Mfg. .169" I.D. X 9/32" O.D. X 1/4")	1/4" Sif. Rtn. Spacer White
67	5	254-5007-05	(507-0004547)	for BRDG1, 2 & 3 and for Mounting Holes	5/16" Sif. Rtn. Spacer White

Sec. 5: PCBs



CPU / SOUND PCB S.A.M. System (520-5246-00) Schematic (Sheet 1 of 5)

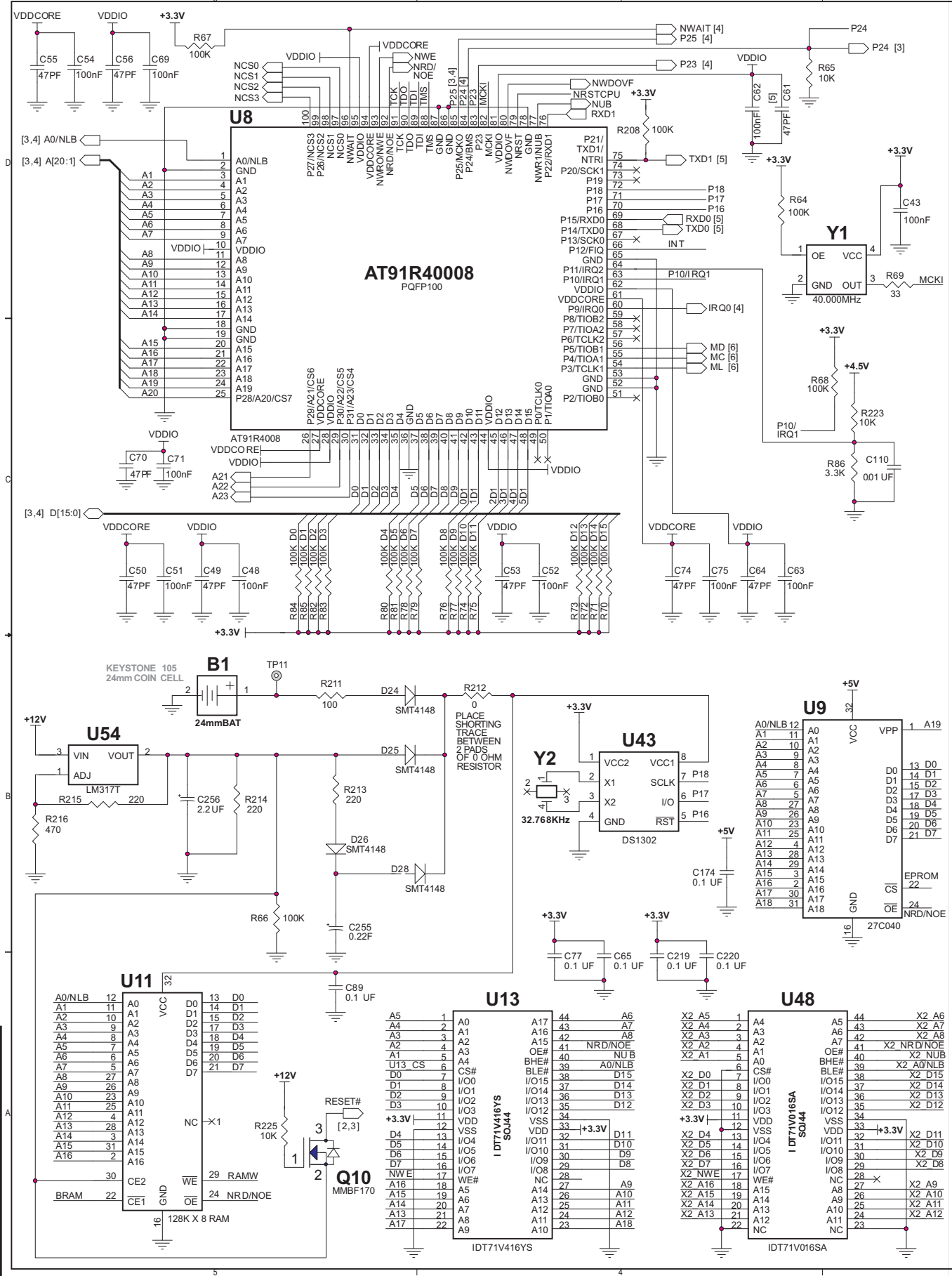

Sec. 5: PCBs



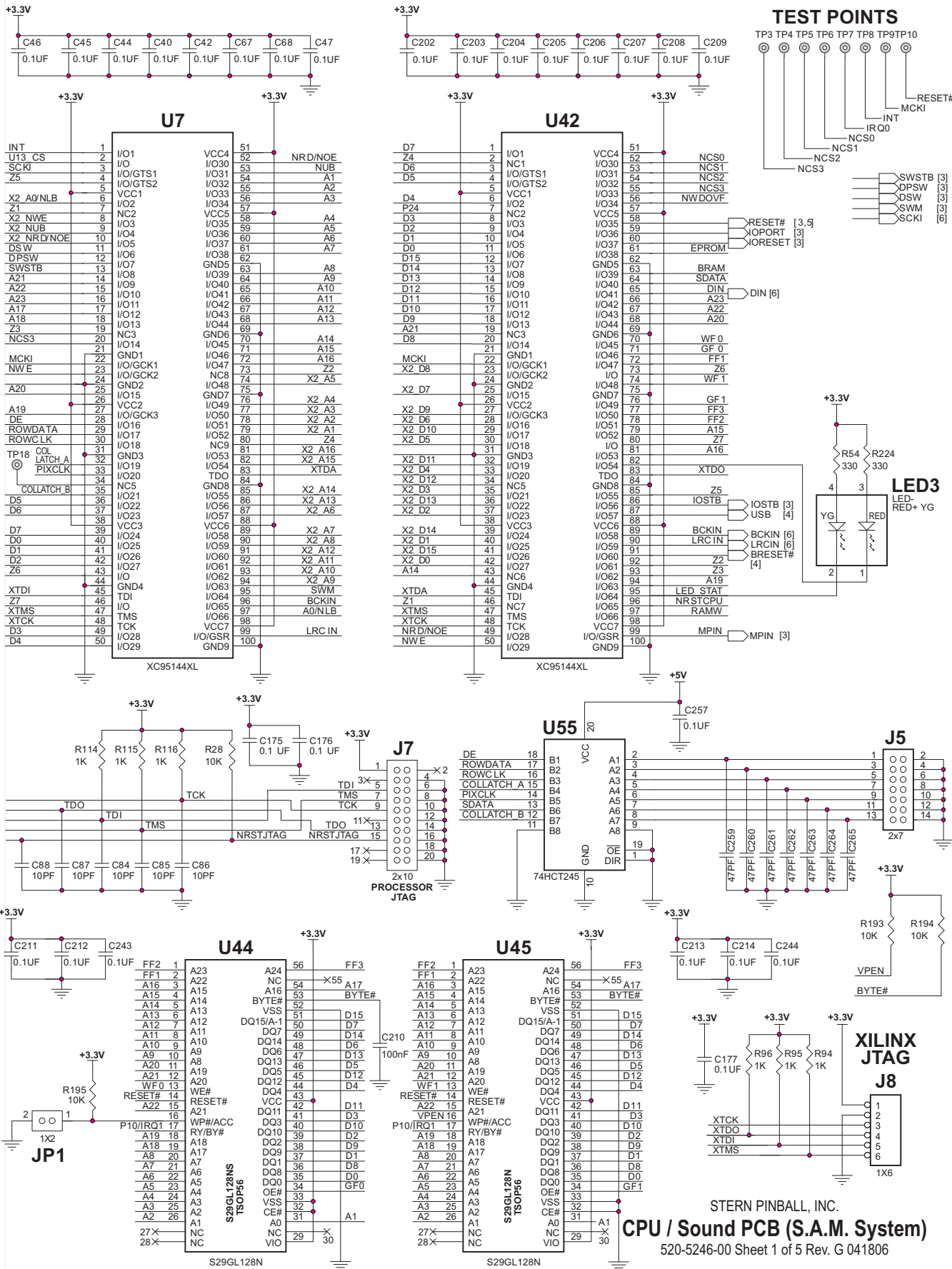

STERN PINBALL, INC.

CPU / Sound PCB (S.A.M. System) 520-5246-00 Sheet 1 of 5 Rev. G 041806

Sec. 5: PCBs



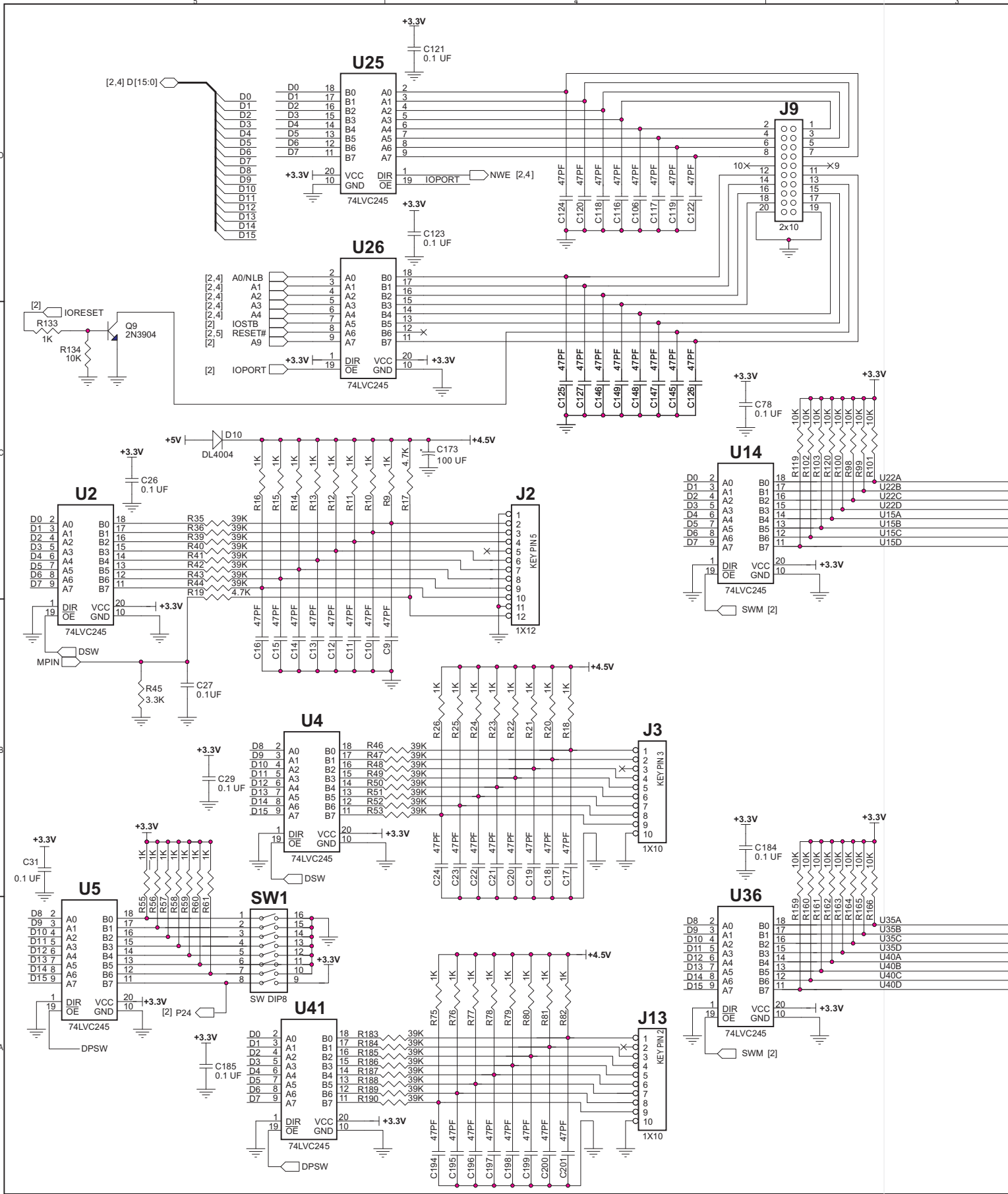

Sec. 5: PCBs



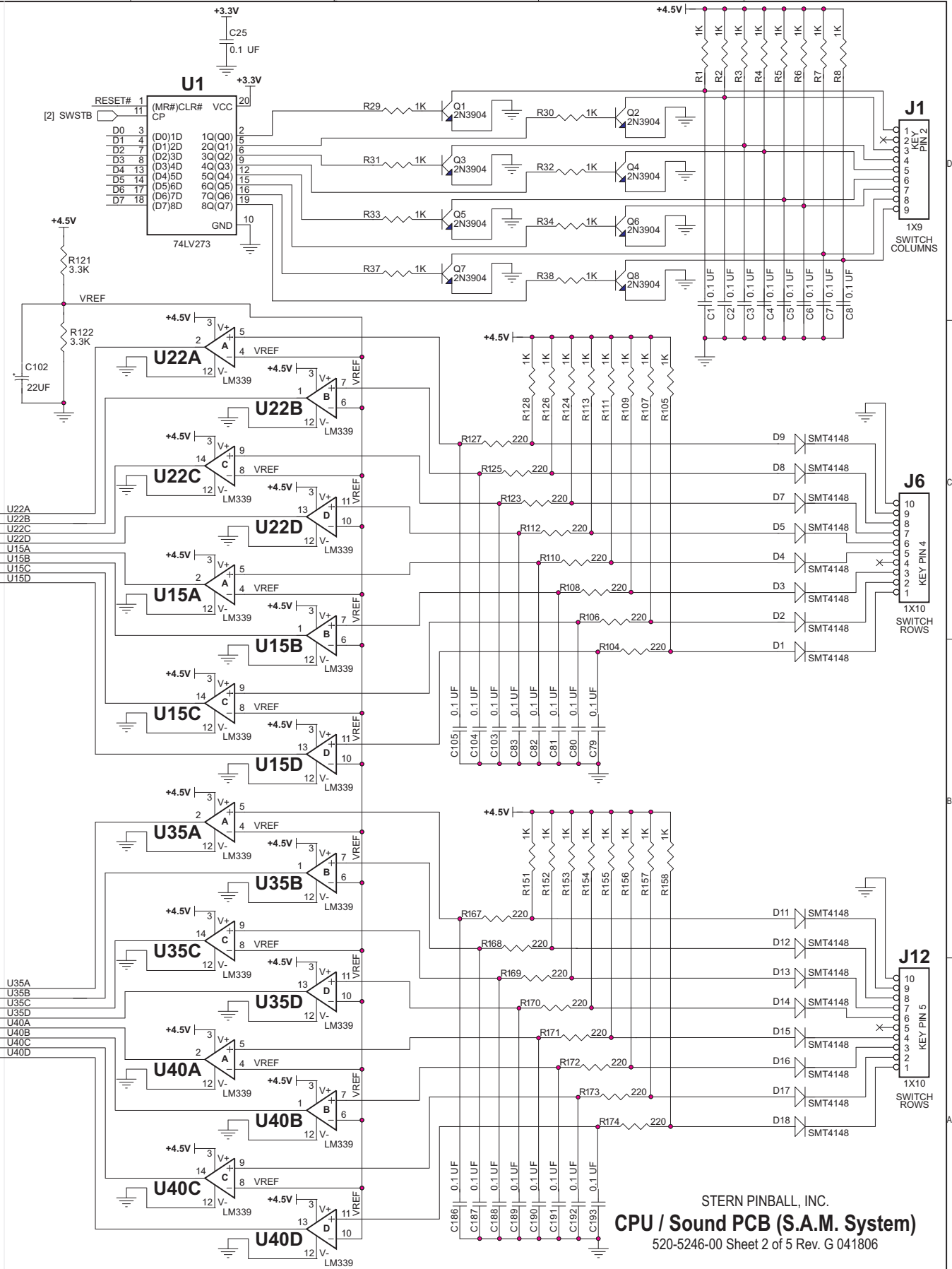

U22A  
U22B  
U22C  
U22D  
U15A  
U15B  
U15C  
U15D

U35A  
U35B  
U35C  
U35D  
U40A  
U40B  
U40C  
U40D

STERN PINBALL, INC.  
**CPU / Sound PCB (S.A.M. System)**  
 520-5246-00 Sheet 2 of 5 Rev. G 041806

Sec. 5: PCBs



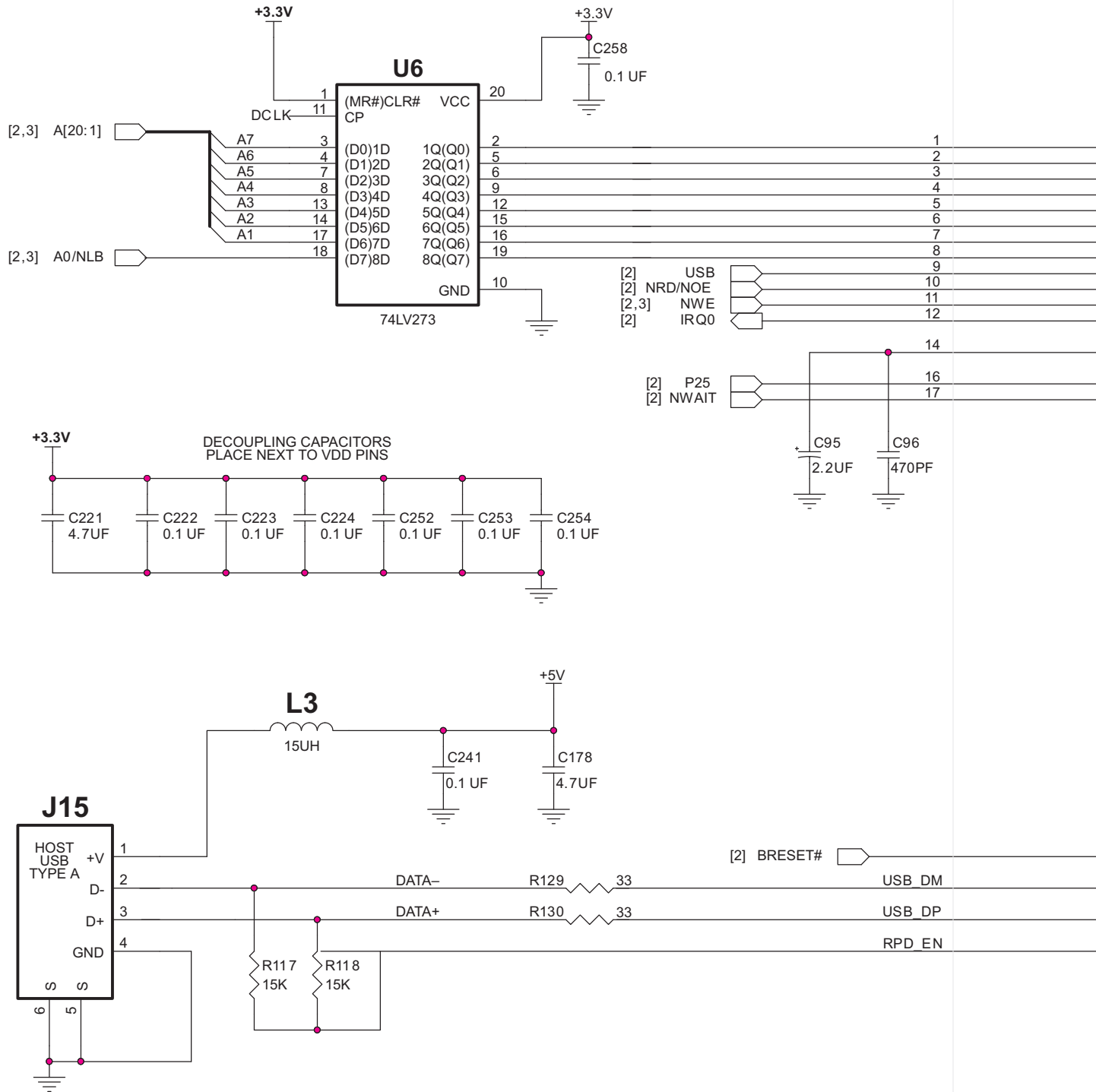

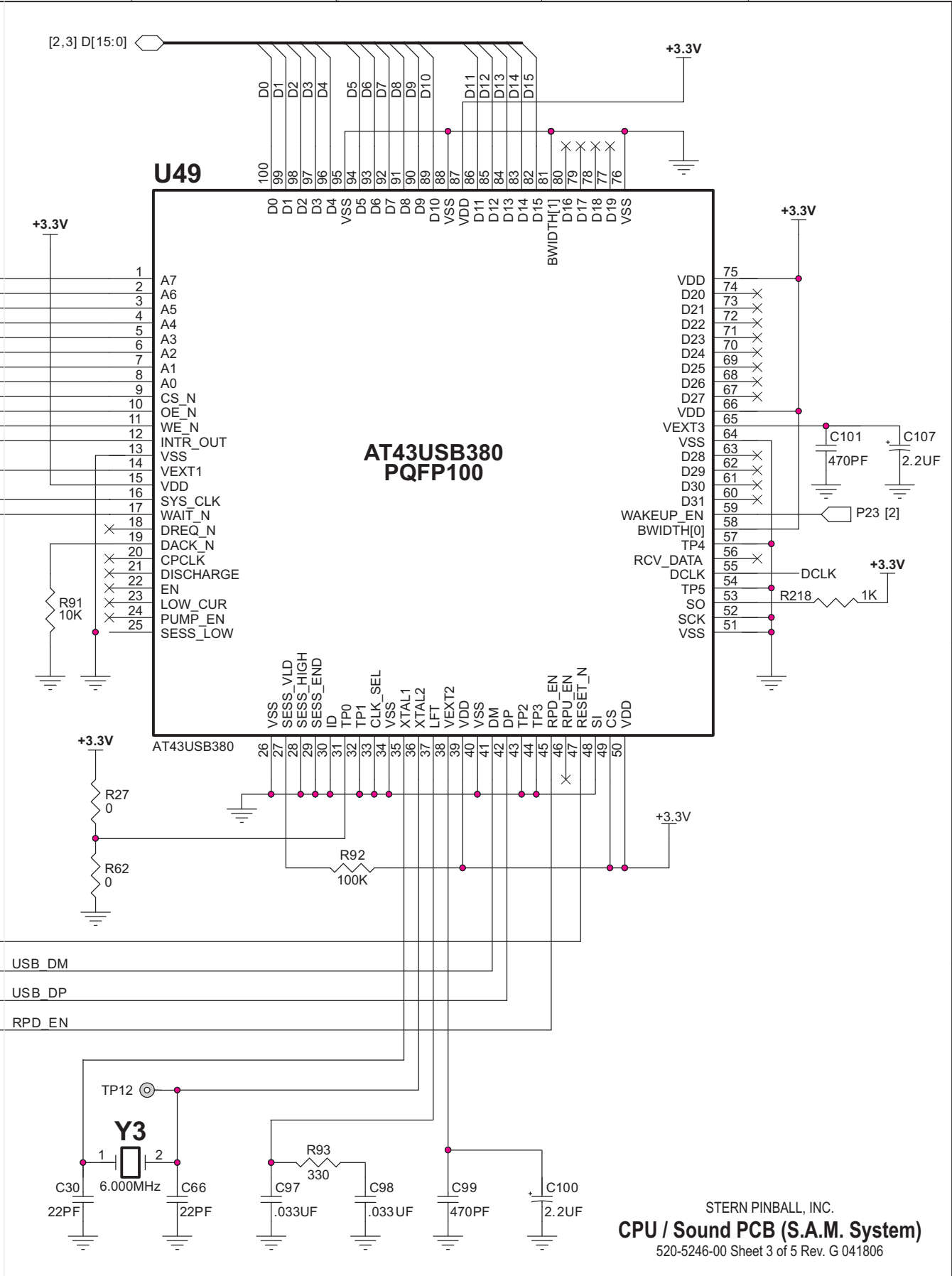

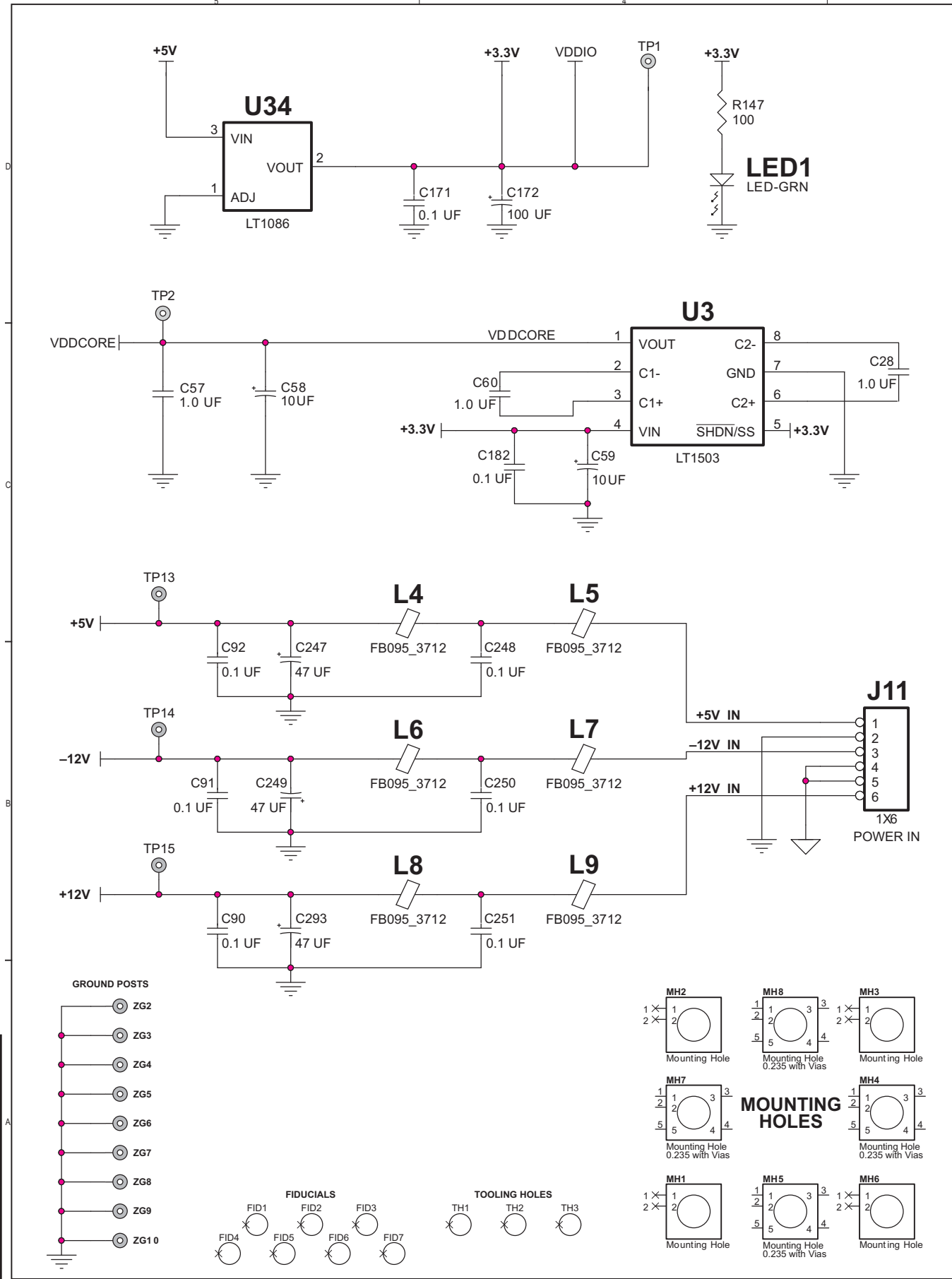

Sec. 5: PCBs





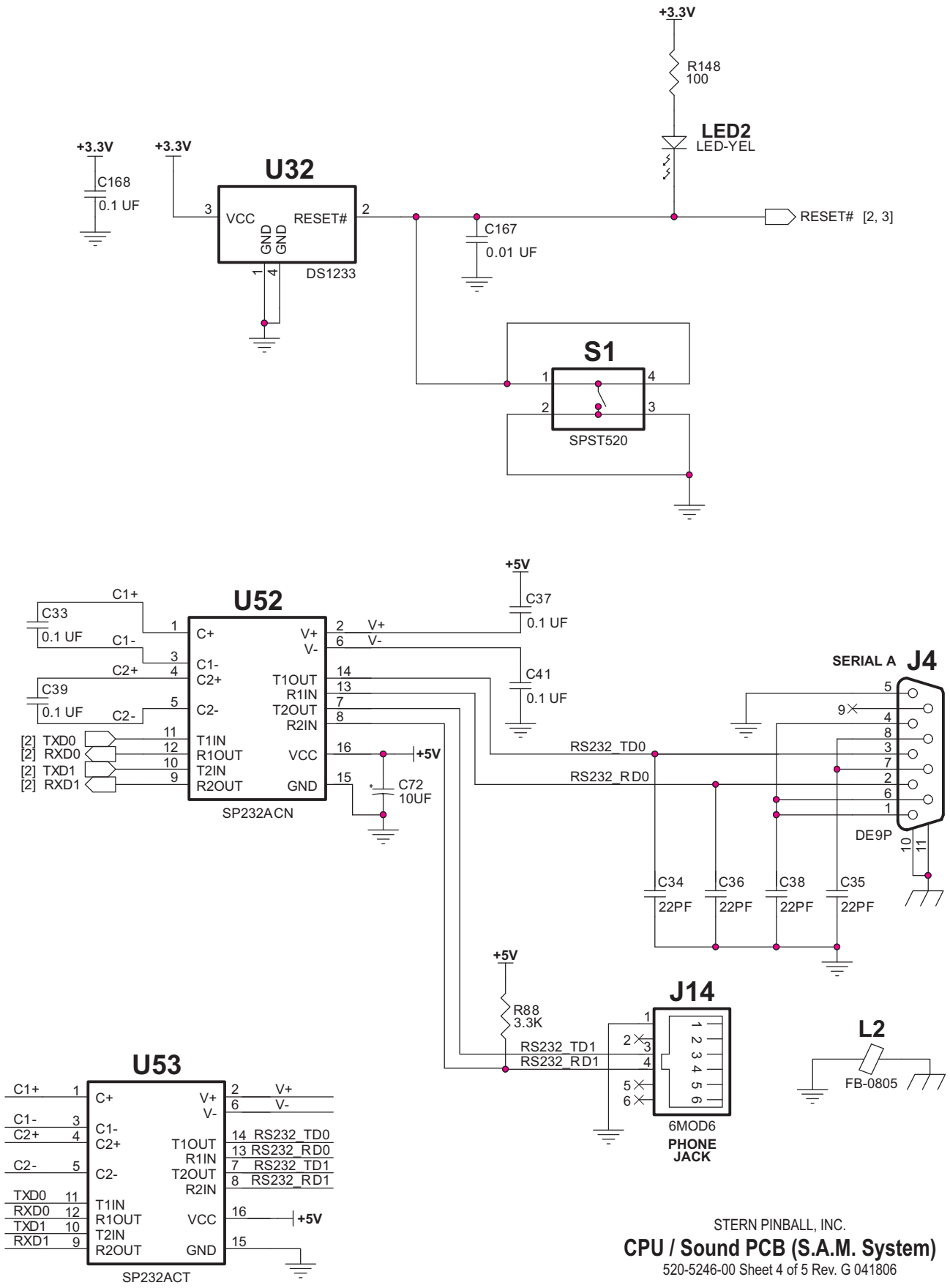

STERN PINBALL, INC.  
**CPU / Sound PCB (S.A.M. System)**  
 520-5246-00 Sheet 4 of 5 Rev. G 041806

Sec. 5: PCBs



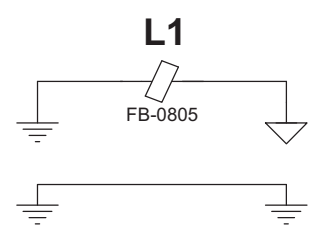
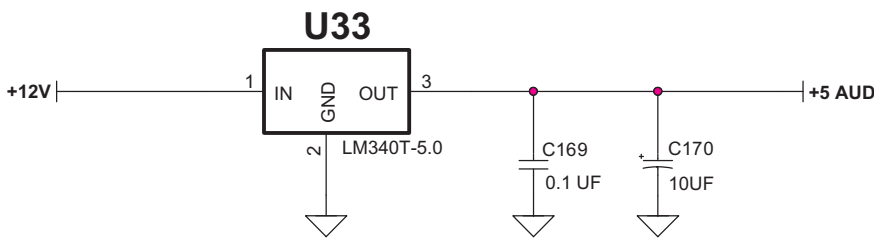
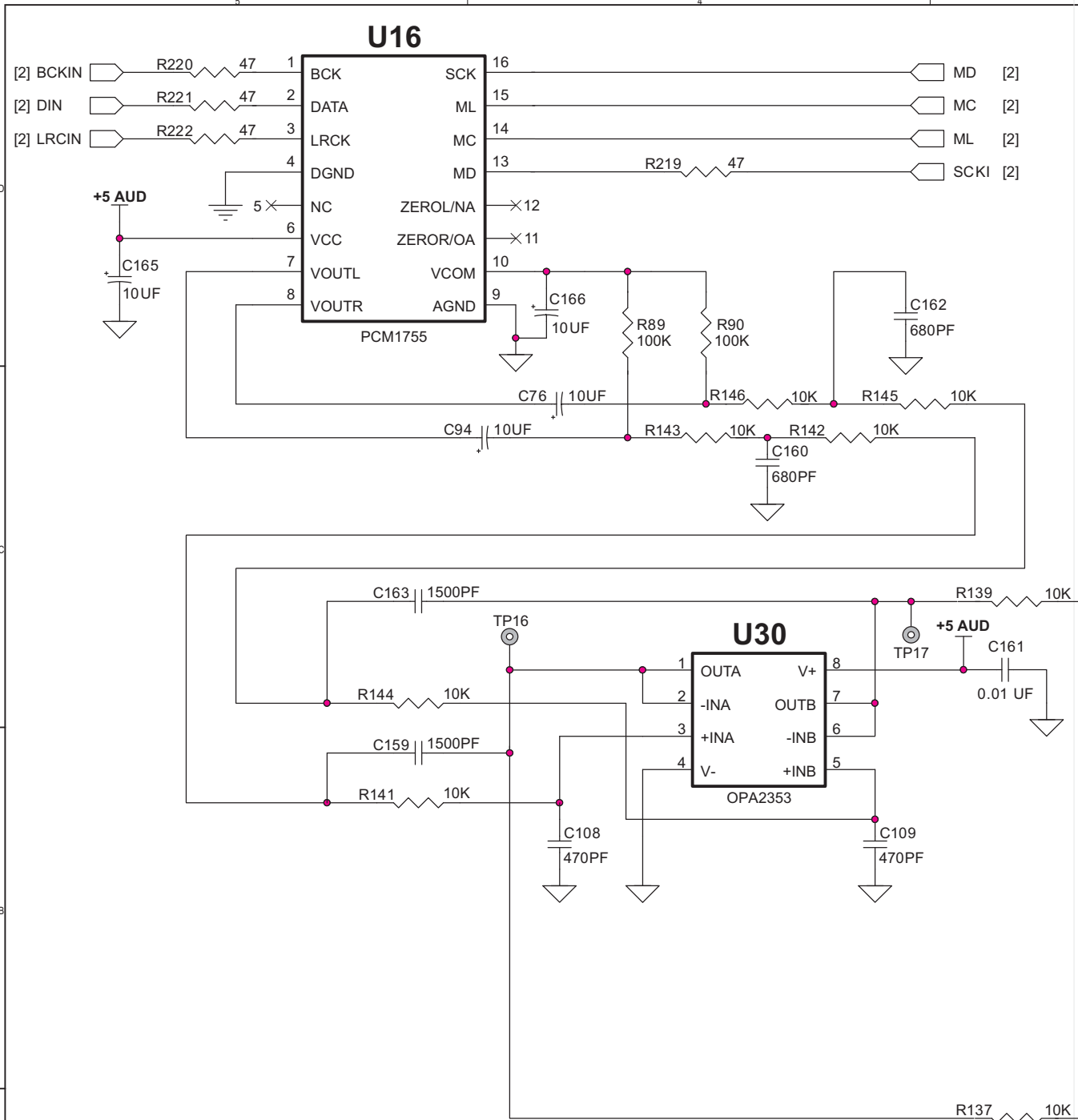

Sec. 5: PCBs



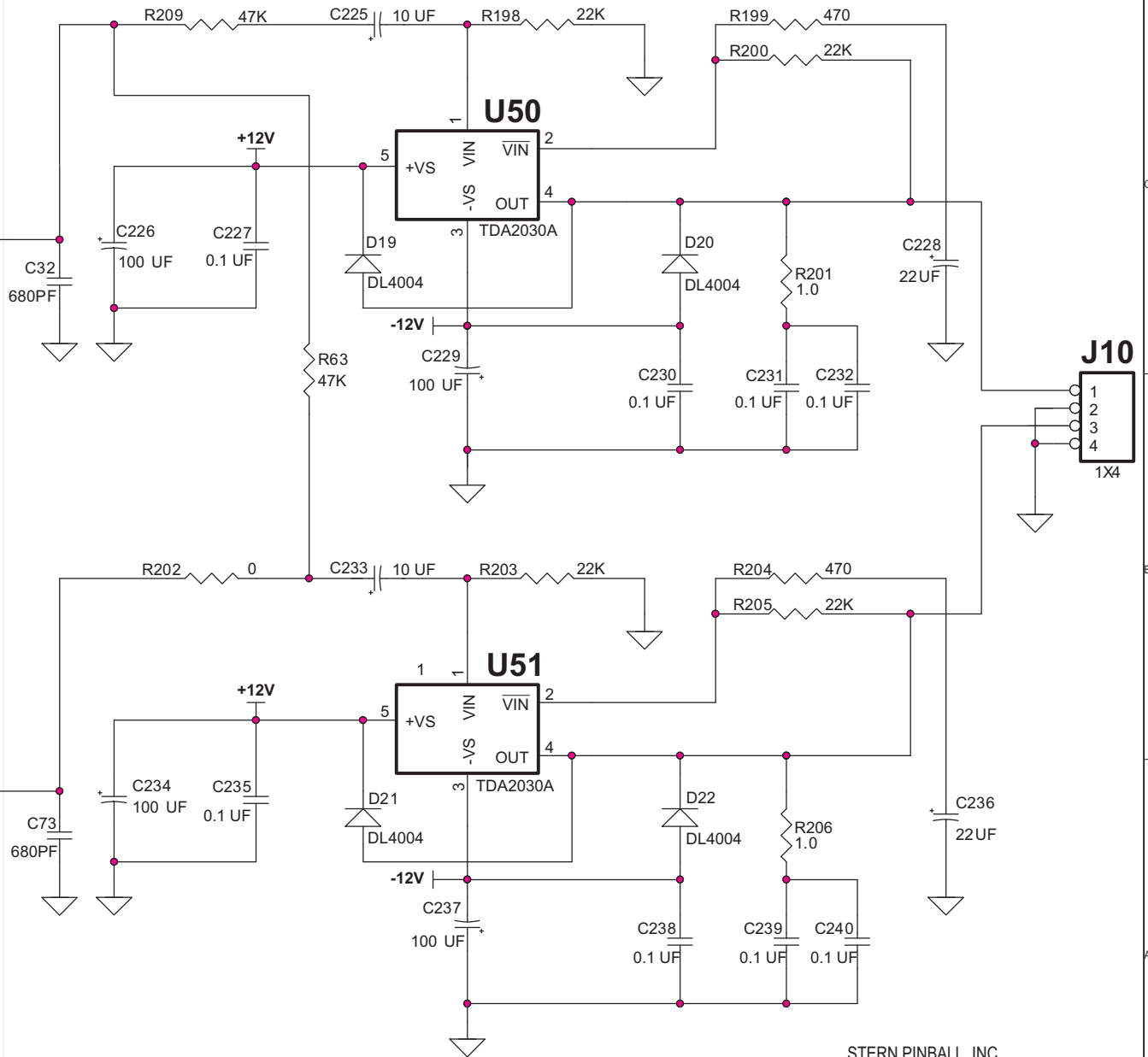

STERN PINBALL, INC.  
**CPU / Sound PCB (S.A.M. System)**  
 520-5246-00 Sheet 3 of 5 Rev. G 041806

Sec. 5: PCBs



# CPU / SOUND PCB S.A.M. System (520-5246-00) Component Layout

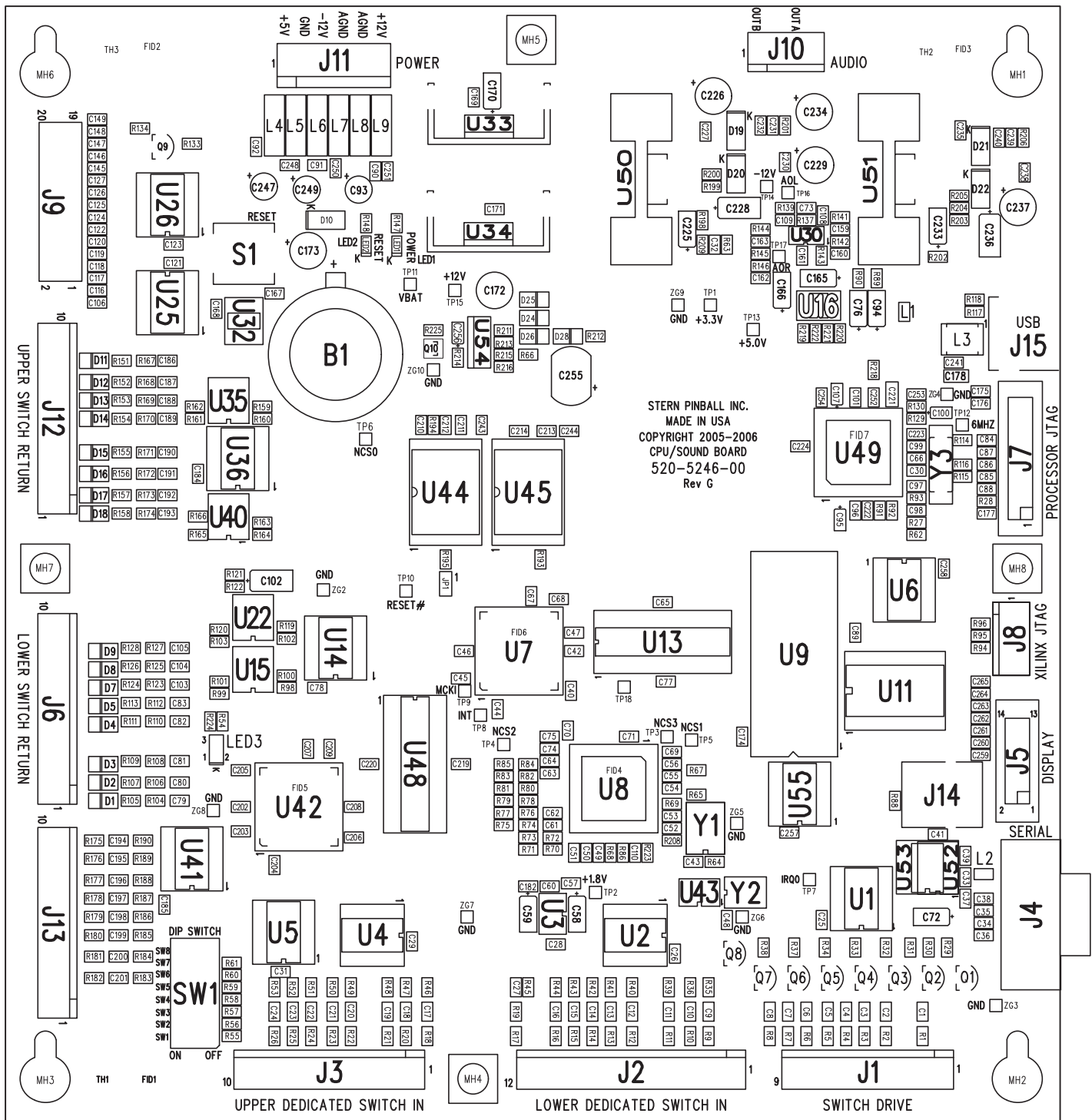

## CPU / SOUND PCB S.A.M. System (520-5246-00) Component Parts

ITEM	QTY.	SPI PART NUMBER (MFG. P.N.)	REF-DESIGNATOR	DESCRIPTION (SM = Surface Mount)
1	1	520-5246-00	CPU/Sound PCB (S.A.M. System), Rev. G	(includes Items 1-90)
2	3	121-6017-00 (101-0001790)	R27, R202, R212	Resistor SM 0805 0.0Ω 1/10W 5%
3	24	121-6108-00 (101-0001792)	R201, R206	Resistor SM 0805 1.0Ω 1/10W 5%
4	3	121-6002-00 (101-0001820)	R9, R10, R11, R12, R13, R14, R15, R16, R18, R20, R21, R22, R23, R24, R25, R26, R175, R176, R177, R178, R179, R180, R181, R182, R147, R148, R211	Resistor SM 0805 Film 100Ω 1/10W 5%
5	24	121-6019-00 (101-0001823)	R64, R66, R67, R68, R70, R71, R72, R73, R74, R75, R76, R77, R78, R79, R80, R81, R82, R83, R84, R85, R89, R90, R92, R208, R28, R65, R91, R98, R99, R100, R101, R102, R103, R119, R120, R134, R137, R139, R141, R142, R143, R144, R145, R146, R159, R160, R161, R162, R163, R164, R165, R166, R193, R194, R195, R223, R225, R117, R118	Resistor SM 0805 100KΩ 1/10W 5%
6	33	121-6020-00 (101-0001827)	R28, R65, R91, R98, R99, R100, R101, R102, R103, R119, R120, R134, R137, R139, R141, R142, R143, R144, R145, R146, R159, R160, R161, R162, R163, R164, R165, R166, R193, R194, R195, R223, R225	Resistor SM 0805 Film 10KΩ 1/10W 5%
7	2	121-6021-00 (101-0001880)	R117, R118	Resistor SM 0805 15KΩ 1/10W 5%

Sec. 5: PCBs



Parts List Continued Next Page.

## CPU / SOUND PCB S.A.M. System (520-5246-00) Parts Continued

ITEM	QTY.	SPI PART NUMBER	(MFG. P.N.)	REF-DESIGNATOR	DESCRIPTION (SM = Surface Mounted)
8	47	121-6022-00	(101-0001905)	R1, R2, R3, R4, R5, R6, R7, R8, R29, R30, R31, R32, R33, R34, R37, R38, R55, R56, R57, R58, R59, R60, R61, R94, R95, R96, R105, R107, R109, R111, R113, R114, R115, R116, R124, R126, R128, R133, R151, R152, R153, R154, R155, R156, R157, R158, R218, LED2	Resistor SM 0805 1K $\Omega$ 1/10W 5%
9	19	121-6004-00	(101-0001943)	R104, R106, R108, R110, R112, R123, R125, R127, R167, R168, R169, R170, R171, R172, R173, R174, R213, R214, R215	Resistor SM 0805 Film 220 $\Omega$ 1/10W 5%
10	4	121-6005-00	(101-0001849)	R198, R200, R203, R205	Resistor SM 0805 Film 22K $\Omega$ 1/10W 5%
11	5	121-6023-00	(101-0001889)	R45, R86, R88, R121, R122	Resistor SM 0805 3.3K $\Omega$ 1/10W 5%
12	3	121-6024-00	(101-0002009)	R69, R129, R130	Resistor SM 0805 33 $\Omega$ 1/10W 5%
13	2	121-6006-00	(101-0002012)	R54, R93	Resistor SM 0805 Film 330 $\Omega$ 1/10W 5%
14	24	121-6013-00	(101-0002035)	R35, R36, R39, R40, R41, R42, R43, R44, R46, R47, R48, R49, R50, R51, R52, R53, R183, R184, R185, R186, R187, R188, R189, R190	Resistor SM 0805 Film 39K $\Omega$ 1/10W 5%
15	2	121-6008-00	(101-0002046)	R17, R19	Resistor SM 0805 Film 4.7K $\Omega$ 1/10W 5%
16	4	121-6014-00	(101-0002065)	R219, R220, R221, R222	Resistor SM 0805 Film 47 $\Omega$ 1/10W 5%
17	3	121-6025-00	(101-0002067)	R199, R204, R216	Resistor SM 0805 470 $\Omega$ 1/10W 5%
18	1	121-6015-00	(101-0002071)	R209	Resistor SM 0805 Film 47K $\Omega$ 1/10W 5%
19	99	125-6001-00	(121-0000056)	C25, C26, C27, C29, C31, C33, C37, C39, C40, C41, C42, C43, C44, C45, C46, C47, C48, C51, C52, C54, C62, C64, C65, C67, C68, C69, C71, C75, C77, C78, C79, C80, C81, C82, C83, C89, C90, C91, C92, C103, C104, C105, C121, C123, C168, C169, C171, C174, C175, C176, C177, C182, C184, C185, C186, C187, C188, C189, C190, C191, C192, C193, C202, C203, C204, C205, C206, C207, C208, C209, C210, C211, C212, C213, C214, C219, C220, C222, C223, C224, C227, C230, C231, C232, C235, C238, C239, C240, C241, C243, C244, C248, C250, C251, C252, C253, C254, C257, C258	Capacitor SM 0805 Cer. 1UF 50V 10% X7R
20	3	125-6013-00	(121-0000077)	C28, C57, C60	Capacitor SM 0805 Cer. 1UF 10V 10% X7R
21	1	125-6014-00	(121-0000086)	C97	Capacitor SM 0805 Cer. 3300PF 50V 5% X7R
22	7	125-6002-00	(121-0000096)	C259, C260, C261, C262, C263, C264, C265	Capacitor SM 0805 Cer. 470PF 50V 5% NPO
23	3	125-6015-00	(121-0000269)	C102, C228, C236	Capacitor SM Case D Tant 22UF 25V 20%
24	11	125-6003-00	(121-0004236)	C1, C2, C3, C4, C5, C6, C7, C8, C110, C161, C167	Capacitor SM 0805 Cer. 0.1UF 50V 10% X7R
25	49	125-6016-00	(121-0004245)	C9, C10, C11, C12, C13, C14, C15, C16, C17, C18, C19, C20, C21, C22, C23, C24, C49, C50, C53, C55, C56, C61, C63, C70, C74, C106, C116, C117, C118, C119, C120, C122, C124, C125, C126, C127, C145, C146, C147, C148, C149, C194, C195, C196, C197, C198, C199, C200, C201	Capacitor SM 0805 Cer. 47PF 50V 5% NPO
26	4	125-6017-00	(121-0005317)	C95, C100, C107, C256	Capacitor SM Case A Tant 2.2UF 16V 10%
27	6	125-6004-00	(121-0005318)	C30, C34, C35, C36, C38, C66	Capacitor SM 0805 Cer. 22PF 100V 5% NPO
28	2	125-6005-00	(121-0006113)	C178, C221	Capacitor SM 1206 Cer. 4.7PF 16V 20% Y5V
29	2	125-6006-00	(121-0007394)	C159, C163	Capacitor SM 603 Cer. 1500PF 25V 10% X7R
30	10	125-6007-00	(121-0007853)	C58, C59, C72, C76, C94, C165, C166, C170, C225, C233	Capacitor SM Case C Tant 10UF 16V 20%
31	1	125-6018-00	(121-0010097)	C98	Cap. SM 805 Cer. .033UF 50V +80/-20% Y5V
32	4	125-6009-00	(121-0010493)	C32, C73, C160, C162	Capacitor SM 805 Cer. 680PF 50V 5% NPO
33	6	125-6019-00	(134-0005415)	C172, C173, C226, C229, C234, C237	Capacitor Tht. Radial Alum. 100UF 35V 20%
34	3	125-6020-00	(134-0007336)	C93, C247, C249	Capacitor Tht. Radial Alum. 47UF 35V 20%
35	1	125-6010-00	(139-0006487)	C255	Capacitor Tht. .22UF 5.5V, Gold, SD, Vert
36	6	125-6011-00	(161-0004959)	L4, L5, L6, L7, L8, L9	Ind.-SM Ferrite 100 $\Omega$ 1234 Smt.
37	2	125-6012-00	(161-0007286)	L1, L2	Ind.-SM 805 Bead 600 $\Omega$ 100MHz 25% 500mA
38	1	125-6021-00	(161-0009686)	L3	Ind.-SM EP Inductor 15uH 1100mA 20%
39	20	125-6000-00	(181-0004347)	D1, D2, D3, D4, D5, D7, D8, D9, D11, D12, D13, D14, D15, D16, D17, D18, D24, D25, D26, D28, D10, D19, D20, D21, D22	Diode SM MiniMELFDL/LL4148 100V 500mW
40	5	112-6001-00	(181-0004478)	Q10	Diode SM MELF DL4004 400V 1.0A
41	1	110-6000-00	(201-0006808)	Q1	Fet-SM SOT-23 MMBF170 N-Chnnl. Fet
42	9	110-0069-00	(213-0003546)	Q1, Q2, Q3, Q4, Q5, Q6, Q7, Q8, Q9	Transistor Tht. TO-92 2N3904 NPN 40V 0.2A
43	1	124-6000-00	(213-0005687)	U34	Trans. Tht. TO-220 LT1086 3.3V 1.5A Volt Reg.
44	8	100-6004-00	(221-0001000)	U2, U4, U5, U14, U25, U26, U36, U41	I.C.-SM SO 74LVC245 Oct. Bus Xcvr.
45	1	100-5048-00	(221-0003716)	U55	I.C.-SM SOIC 74HCT245DW Octal Line Xvr. W/3S
46	4	100-6005-00	(221-0003718)	U15, U22, U35, U40	I.C.-SM SO LM339 Quad Diff. Comp.
47	1	100-6006-00	(221-0005249)	U43	I.C.-SM SOIC DS1302 Time Keeper
48	1	100-6008-00	(221-0006578)	U52	I.C.-SM SOIC SP232A SO-16
49	1	100-6009-00	(221-0006914)	U32	I.C.-SM SOT-223 DS1233A2-15 Reset
50	1	100-6007-00	(221-0006919)	U30	I.C.-SM OPA2353 Dual CMOS OpA MSOP-8
51	1	100-6018-00	(221-0006940)	U48	I.C.-SM SOJ IDT71V016SA15Y SOJ-44
52A	1	100-6016-00	(221-0007056)	U7 (must be programmed)	U7 (I.C.-SM TQFP CPLD 144 Macro Cell 3.3V)
52B	1	100-6017-00	(221-0007056)	U42 (must be programmed)	U42 (I.C.-SM TQFP CPLD 144 Macro Cell 3.3V)
53	1	124-6001-00	(221-0007298)	U3	I.C.-SM SOIC LT1503CS8-1.8
54	1	100-6012-00	(221-0010735)	U11	I.C.-SM SOIC CY62128 SRAM 128Kx8 3V LP SO32
55	1	100-6013-00	(221-0010736)	U49	I.C.-SM QFP-L AT43 USB380 Processor USB 2.0
56	1	100-6014-00	(221-0010738)	U16	I.C.-SM SSP PCM1755 24-Bit Audio DAC 16-Pi
57	1	100-6010-00	(221-0010978)	U13	I.C.-SM SOJ IDT71V416S15Y SOJ-44
58	1	100-6011-00	(221-0010981)	U44	I.C.-SM TSOP S29GL256N11 256MB Flash
59	1	100-6015-00	(221-0011102)	U1	I.C.-SM SOIC 74LV273 SOIC-20
60	1	124-6002-00	(225-0003581)	U54	I.C.-Tht. TO-220 LM317T Adjustable Volt Reg.
61	2	100-5016-20	(225-0003635)	U50, U51	I.C.-Tht. Pentawat TDA2030 18W Amplifier
62	1	124-6003-00	(225-0006921)	U33	I.C.-Tht. TO-220 LM340T 5V 1A Volt Regulator
63	1	077-5217-00	(301-0004285)	SU9	Socket DIP/SIP 32-Pin, Tin, .6, Dip
64	2	n/a	(303-0005944)	TP1, TP2	Test Pt. All Test Point, White, Miniature
65	1	045-	(315-0003511)	JP1	Con.-Tht. Header 2 Pin, 1 Row, VT, Tin, .1"
66	1	045-	(315-0004097)	J11	Con.-Tht. Header 6 Pin, 1 Row, VT, Tin, .156"
67	1	045-	(315-0004121)	J1	Con.-Tht. Header 9 Pin, 1 Row, VT, Tin, .156"
68	4	045-	(315-0004122)	J3, J6, J12, J13	Con.-Tht. Hdr. 10 Pin, 1 Row, VT, Tin, .156"
69	1	045-	(315-0004124)	J8	Con.-Tht. Header 6 Pin, 1 Row, VT, Tin, .1"
70	1	045-	(315-0006776)	J14	Con.-Tht. Hdr. 6 Pos. Phone Jack, Vertical
71	1	045-	(315-0006910)	J9	Con.-Tht. Header 20 Pin, 2 Row, VT, Tin, .1"
72	1	045-	(315-0009252)	J10	Con.-Tht. Header 4 Pin, 1 Row, VT, Tin, .156"
73	1	045-	(315-0009520)	J2	Con.-Tht. Hdr. 12 Pin, 1 Row, VT, Tin, .156"
74	1	045-	(315-0009626)	J15	Con.-Tht. 4 Pos. USB Recept, VT, WHT/BLK
75	1	045-	(315-0009627)	J4	Con.-Tht. D-Sub 9 Pos, VT, w/lock & Hex Sc.
76	1	045-	(315-0010979)	J5	Con.-Tht. Hdr. 14 Pin, 2 Row, VT, Gold, .1" Shrou.
77	1	140-6000-00	(401-0007295)	Y2	XTAL -SM 32.768MHz Cl 12.5 FSR327
78	1	140-6001-00	(401-0010737)	Y3	XTAL -SM 600MHz 20PF
79	1	140-6002-00	(403-0005489)	Y1	Osc.-SM SO 400MHz 5V Tristate CMOS
80	1	515-	(421-0010979)	B1	Battery (Coin Cell 24.5mm) Holder with clip
81	1	000-0644-01	(421-0010980)	for B1	Coin Cell 3V 265mAh 24X3 mm (CR2430)
82	1	165-6003-00	(425-0005320)	LED1	LED SM Green 0805 LED
83	1	165-6004-00	(425-0010803)	LED3	LED SM Dual Red/Green 1210 Top
84	1	182-5002-00	(450-0004750)	SW1	8-Position Dip Switch Spst. 16 Pin X8 Slide 5VDC 100ma White Push-Button Reset Switch Spst. 4 Pin Momentary 24VDC 50ma
85	1	182-5001-00	(450-0004752)	S1	Heatsink All Vert Mount Ba TO-220 Heatsink All Vert Mount Ba TO-220 #4-40 X 3/8" PPH MS Sems (Zinc) Screw #4-40 Keps Nut 5/16" Sif. Rtn. Spacer White
86	2	127-5001-00	(461-0003520)	for U33, U34	
87	2	127-5001-01	(461-0003528)	for U50, U51	
88	4	237-5909-01	(504-0004604)	for Heat Sinks U33, U34, U50, U51	
89	4	240-5318-00	(503-0004457)	for Heat Sinks U33, U34, U50, U51	
90	4	254-5007-05	(507-0004547)	for Mntg. Holes (Mfg. .169" I.D. X 9/32" O.D. X 5/16")	

Sec. 5: PCBs



# Display Power Supply PCB (520-5138-00) Schematic

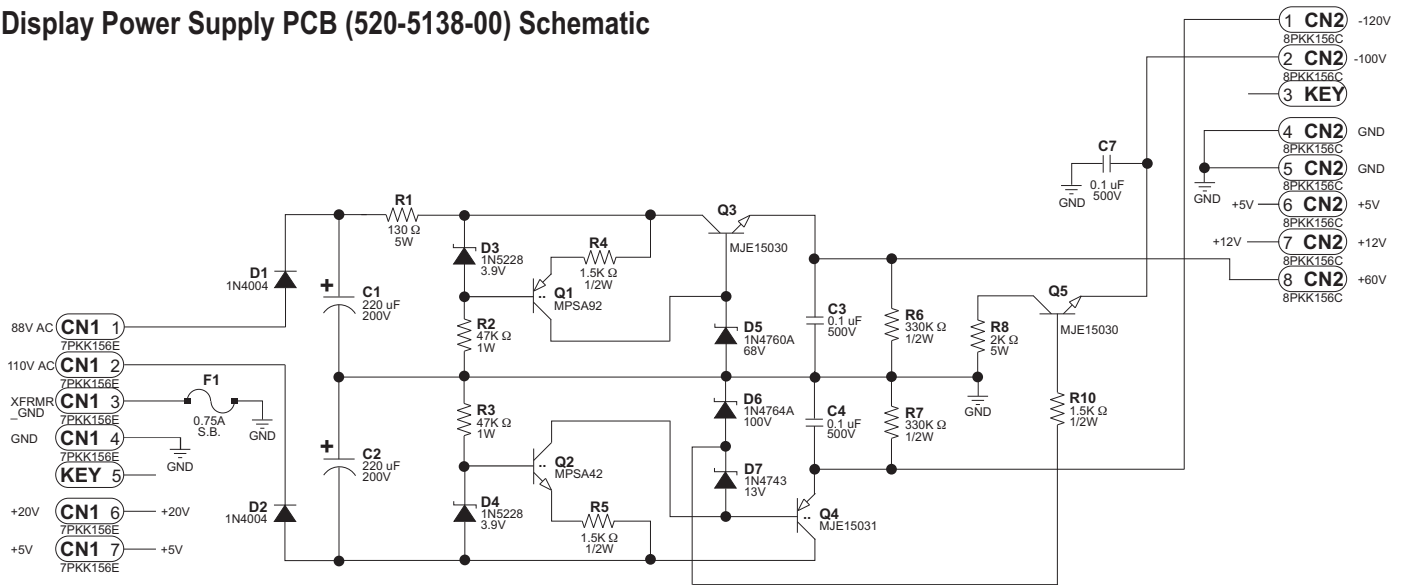

# Display Power Supply PCB (520-5138-00) Component Layout & Parts

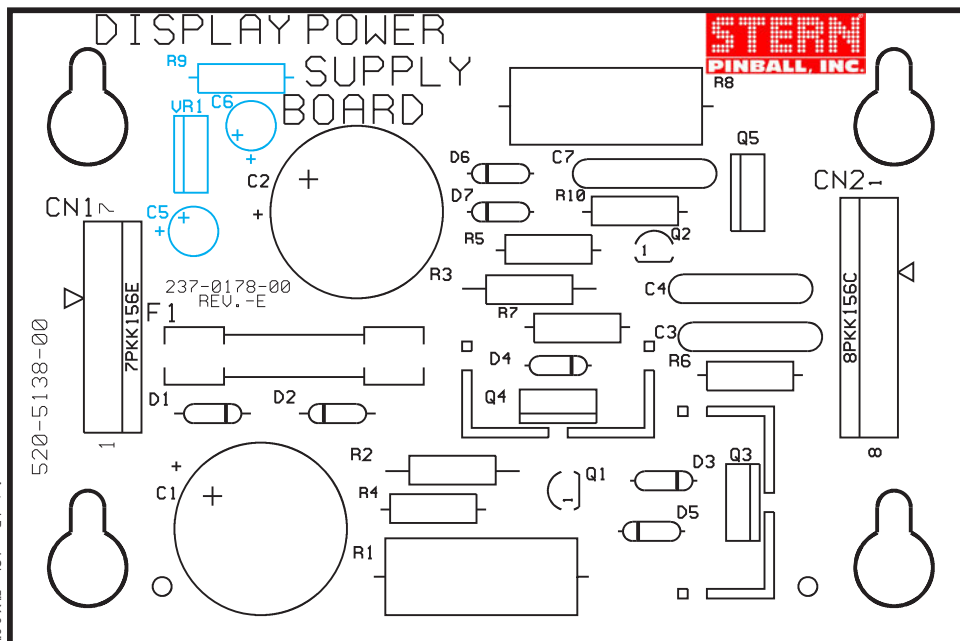

ITEM	QTY	PART NUMBER	REF-DESIGNATOR	DESCRIPTION (NS = Not Stuffed)
1	1	520-5138-00	Display Power Supply PCB	(includes Items 1-2 + 4-24)
2	2	125-5044-00	C1, C2	220uF, 200v, Radial Lytic Cap.
3	3	125-5035-00	C3, C4, C7	0.1uF, 500v, Ceramic Disk Cap.
4	0	125-5003-00	(C5, C6: NS)	22uF, 35v, Rad Lytic Cap
5	1	045-5015-07	CN1	7PKK156E (PIN5=KEY)
6	1	045-5015-08	CN2	8PKK156 (PIN3=KEY)
7	2	112-5003-00	D1, D2	1N4004, Diode
8	2	112-0053-00	D3, D4	1N5228, 3.9v, Diode
9	1	112-0062-00	D5	1N4760A, 68v, Diode
10	1	112-0049-00A	D6	1N4764A, 100v, Diode
11	1	112-0061-00	D7	1N4743, 13v, Diode
12	1	200-5000-17	F1	3/4A (0.75A) S.B. Fuse
13	2	205-0004-00	F1	Fuse Clip
14	1	110-0100-00	Q1	MPSA92, Transistor
15	2	110-0082-00	Q2, Q5	MPSA42, Transistor
16	2	110-0101-00	Q3, Q4	MJE15030, Transistor
17	2	535-5000-11	Q3, Q4	Heatsinks - AAVID #563002
18	2	240-5008-00	Q3, Q4	#6-32 KEPS Nut
19	2	237-5501-00	Q3, Q4	#6-32 X 3/8" PPH Screw
20	1	110-0103-00	Q4	MJE15031, Transistor
21	1	121-5061-00	R1	130 Ω Resistor SMT, 5W
22	2	121-5060-00	R2, R3	47k Ω Resistor SMT, 1W
23	3	121-5038-00	R4, R5, R10	1.5K Ω Resistor SMT, 1/2W (R9: NS)
24	2	121-5059-00	R6, R7	330K Ω Resistor SMT, 1/2W
25	1	121-5062-00	R8	2K Ω Resistor SMT, 5W
26	0	124-5003-00	(VR1: NS)	7812CT

Sec. 5: PCBs



## Playfield Switches OPTO Transceiver PCBs (500-6775-00) Schematic

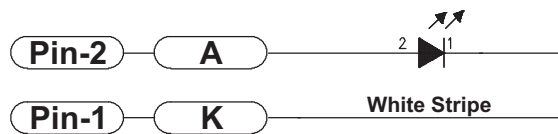

**Mini PCB  
OPTO 12" Lead  
(Black Bracket)  
500-6775-00**

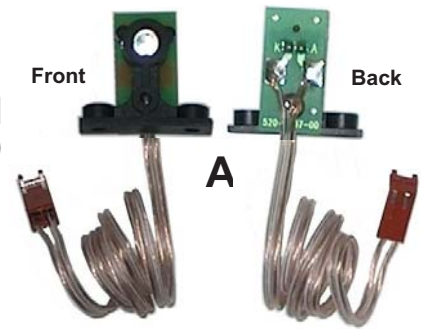

## Playfield Switches OPTO Transceiver PCBs (500-6775-00) Component Layout & Parts

ITEM	QTY	PART NUMBER	REF-DESIGNATOR	DESCRIPTION
<b>A</b>	<b>5 pair</b>	<b>500-6775-00</b>	<b>MINI PCB OPTO ASM WHT / 12" LEAD</b>	<b>PCB Assy. (with all Items 1-5)</b>
—	<b>1</b>	<b>520-5237-00</b>	<b>Mini OPTO Trans. or Rec. Board</b>	<b>PCB Only Plain</b>
01	1	545-6092-00		Black Bracket (Plastic) Holder
02	1	237-5909-00		#4-40 X 1/4 PPH Screw
03	1	165-5052-00		LED (Ultra Bright Red)
04	1	601-5023-12	K, A	12" Speaker Wire (1-Side White Stripe)
05	1	045-5020-02	Note White Strip to Pin-1	2-Pin Cn., .100 KK Cmp Trm Molex 08-50-0113

## Playfield OPTO Transmitter / Receiver Amplifier PCB (520-5239-01) Schematic

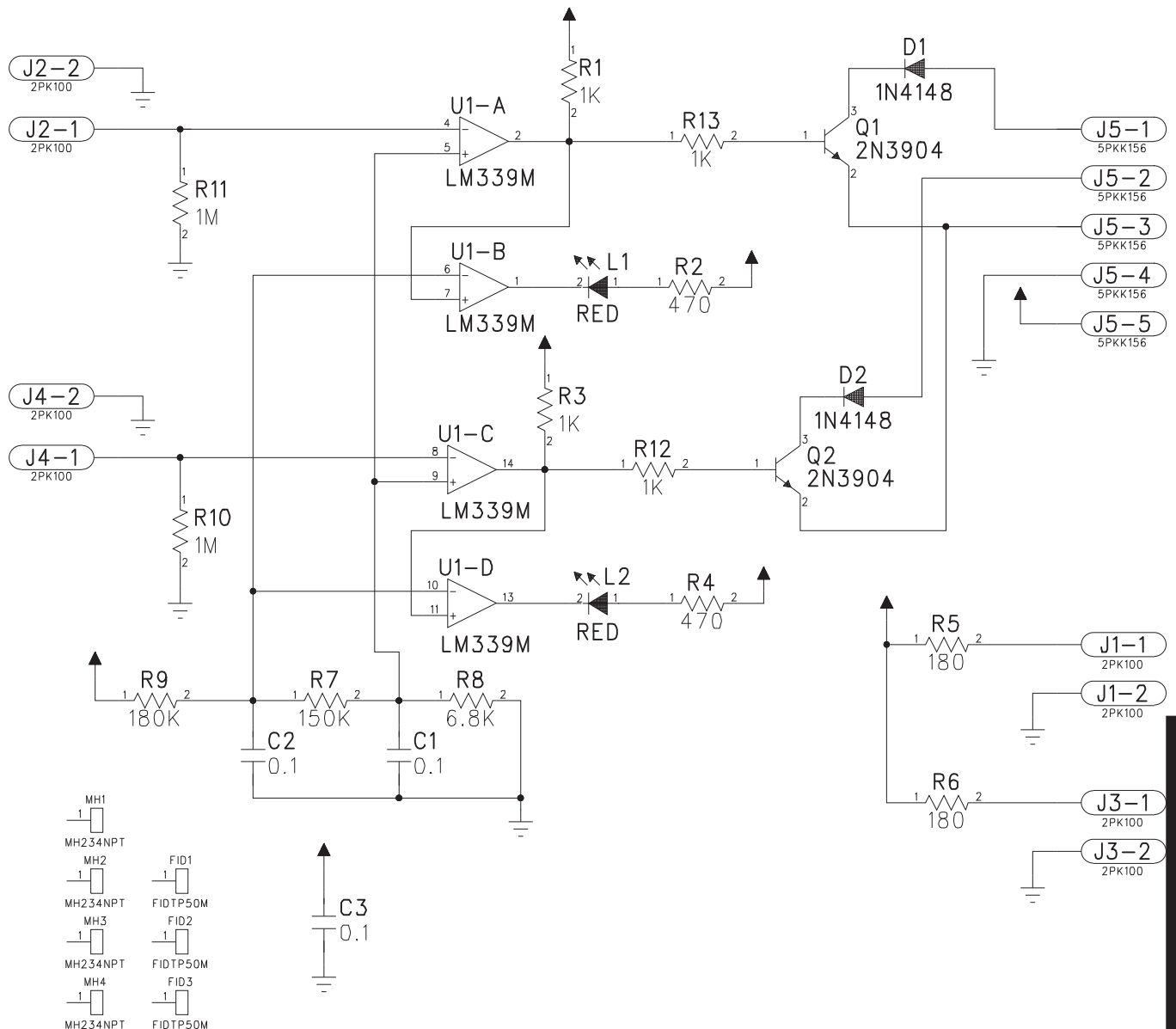

**Sec. 5: PCBs**



# Playfield OPTO Transmitter/Receiver Amplifier PCB (520-5239-01) Component Layout & Parts

(for OPTO Switches 52, 54, 56 & 59)

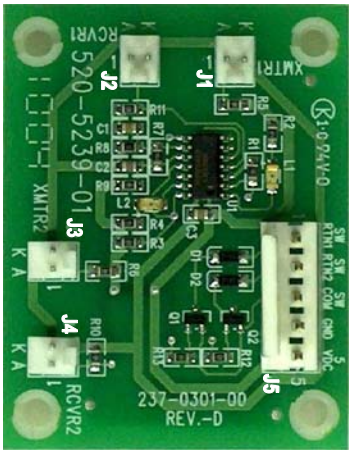

Front

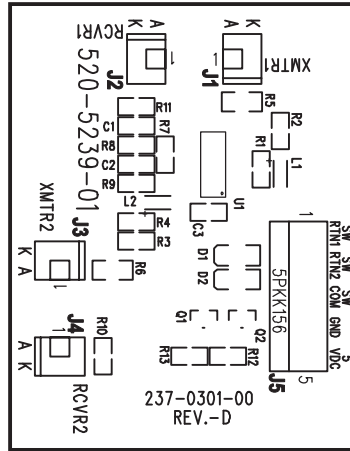

Front

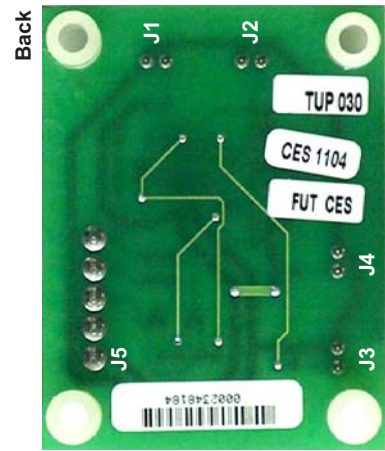

Back

ITEM	QTY	PART NUMBER	REF-DESIGNATOR	DESCRIPTION
01	3	520-5239-01	OPTO Transmitter/Receiver Amplifier Board	Complete PCB Assembly
02	2		R7	SMT 150K $\Omega$ 1/10W Resistor 805, 5%
03	1		R5, R6	SMT 180 $\Omega$ 1/10W Resistor 805, 5%
04	4		R9	SMT 180K $\Omega$ 1/10W Resistor 805, 5%
05	2		R1, R3, R12, R13	SMT 1K $\Omega$ 1/10W Resistor 805, 5%
06	2		R10, R11	SMT 1M $\Omega$ 1/10W Resistor 805, 5%
07	2		R2, R4	SMT 470 $\Omega$ 1/10W Resistor 805, 5%
08	1		R8	SMT 6.8K $\Omega$ 1/10W Resistor 805, 5%
09	3		C1, C2, C3	SMT Cer. .1 $\mu$ F 50v Cap., 10% X7R
10	2		D1, D2	1N4148W, Diode, 100v, 350MW
11	1		Q1, Q2	MMST3904, NPN, 40v, .02A
12	4	Mfg. 22-23-2021	J1, J2, J3, J4	LM339M, Low Power Offset QUA
13	1	Mfg. 640445-5	J5	2-Pin, 0.1 Header (1 Row, VT, Tin)
14	2	Mfg. APT3216SURC	L1, L2	5-Pin, .156 Header (1 Row, VT, Tin)
15	4		n/a	LEDD-SMT, Red 1206 Spacer (Nylon), .153" ID X 9/32" OD X 3/8"

**Complete PCB Assembly**  
 SMT 150K  $\Omega$  1/10W Resistor 805, 5%  
 SMT 180  $\Omega$  1/10W Resistor 805, 5%  
 SMT 180K  $\Omega$  1/10W Resistor 805, 5%  
 SMT 1K  $\Omega$  1/10W Resistor 805, 5%  
 SMT 1M  $\Omega$  1/10W Resistor 805, 5%  
 SMT 470  $\Omega$  1/10W Resistor 805, 5%  
 SMT 6.8K  $\Omega$  1/10W Resistor 805, 5%  
 SMT Cer. .1 $\mu$ F 50v Cap., 10% X7R  
 1N4148W, Diode, 100v, 350MW  
 MMST3904, NPN, 40v, .02A  
 LM339M, Low Power Offset QUA  
 2-Pin, 0.1 Header (1 Row, VT, Tin)  
 5-Pin, .156 Header (1 Row, VT, Tin)  
 LEDD-SMT, Red 1206  
 Spacer (Nylon), .153" ID X 9/32" OD X 3/8"

## Playfield OPTO Transmitter/Receiver Amplifier PCB (520-5239-01) Wiring (General)

(for Board 1: OPTO Switches 4 & 11; Bd. 2: OPTO Sw. 3; Bd. 3: OPTO Sws. 60 & 61)

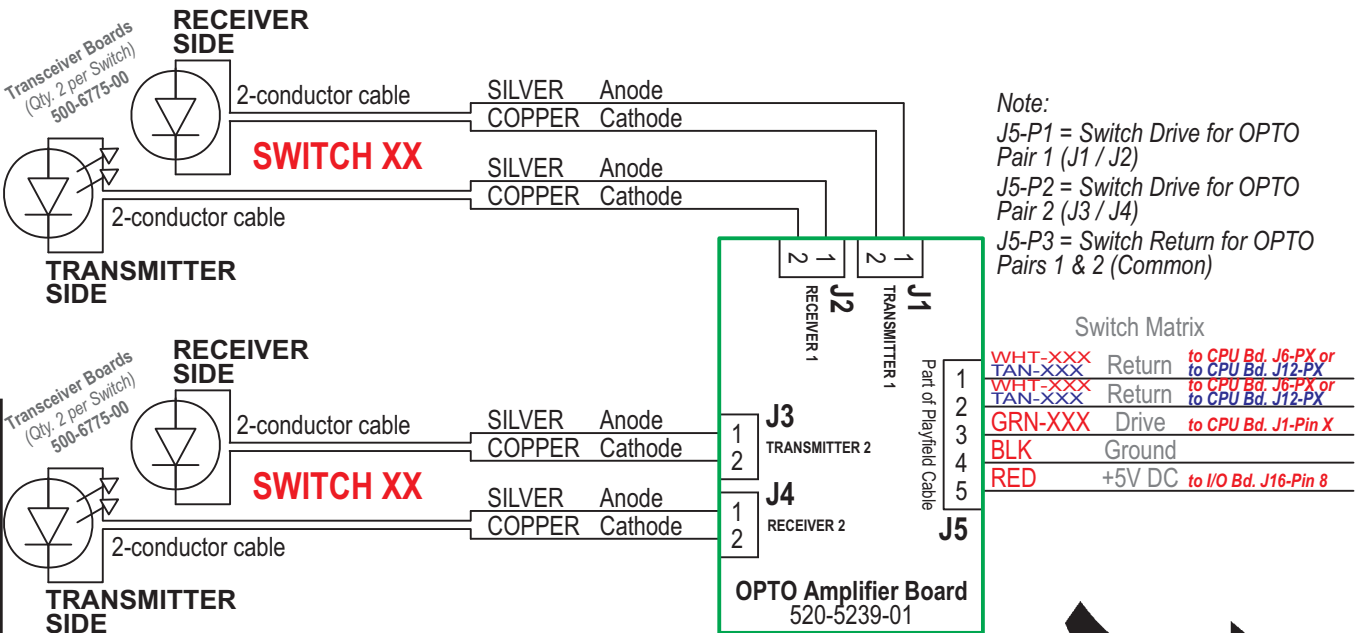

For details on Board Wiring Configuration for Boards 1 – 3, see opposite pages.

Sec. 5: PCBs





# Playfield Switches OPTO Transceivers & Transmitter/Receiver Amplifier PCB Locations

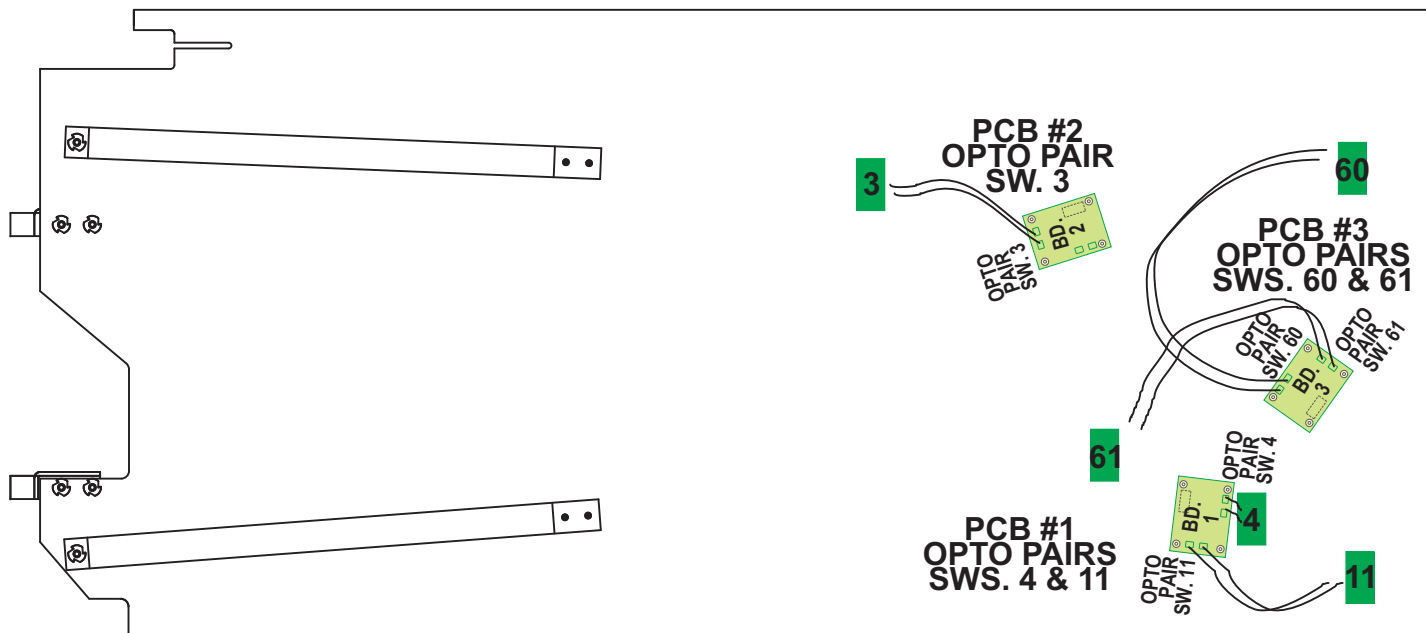

## Playfield OPTO Transmitter/Receiver Amplifier PCB (520-5239-01) Wiring (Game Specific)

Board 1: OPTO Switches 4 [Plunder Exit] & 11 [Plunder Enter] **Location: Upper Left Corner**

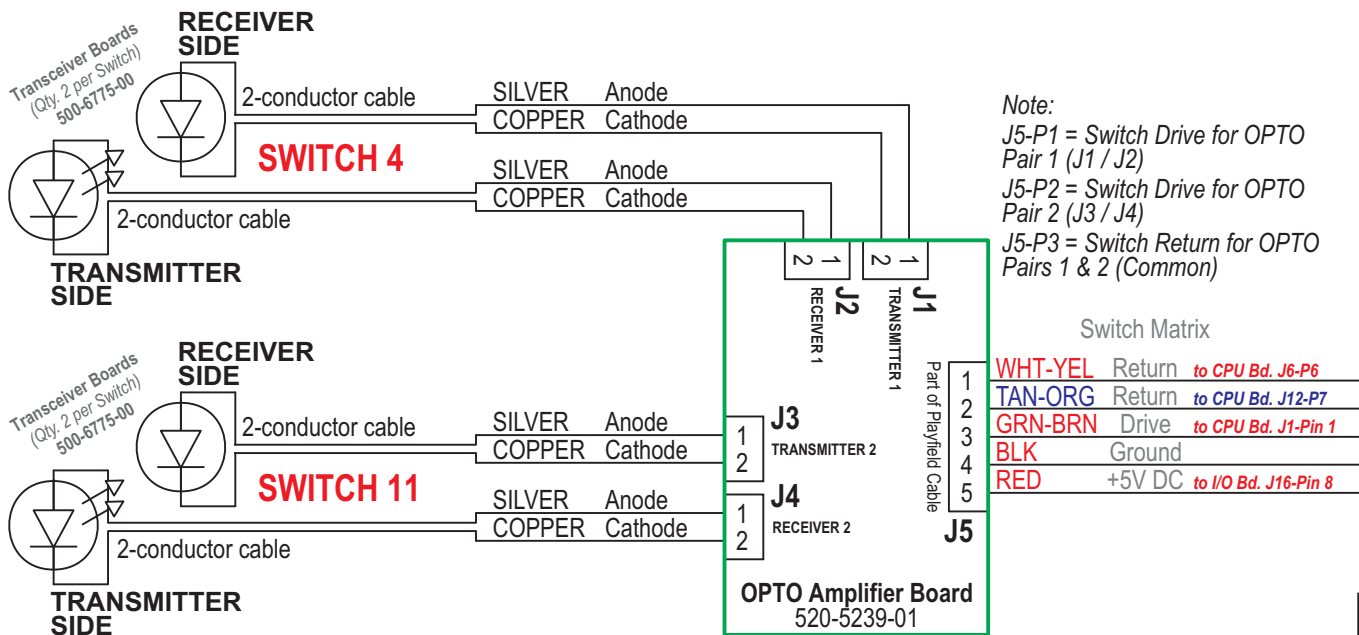

Note:  
 J5-P1 = Switch Drive for OPTO Pair 1 (J1 / J2)  
 J5-P2 = Switch Drive for OPTO Pair 2 (J3 / J4)  
 J5-P3 = Switch Return for OPTO Pairs 1 & 2 (Common)

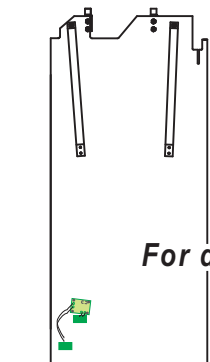

Printed Circuit Boards (PCBs)

For details on Board Wiring Configuration for Boards 2 – 3, see opposite page.



**Playfield OPTO Transmitter/Receiver Amplifier PCB (520-5239-01) Wiring (Game Specific)**  
**Board 2: OPTO Switch 3 [Hit (Treasure) Chest (Enter)] Location: Middle Right Playfield**

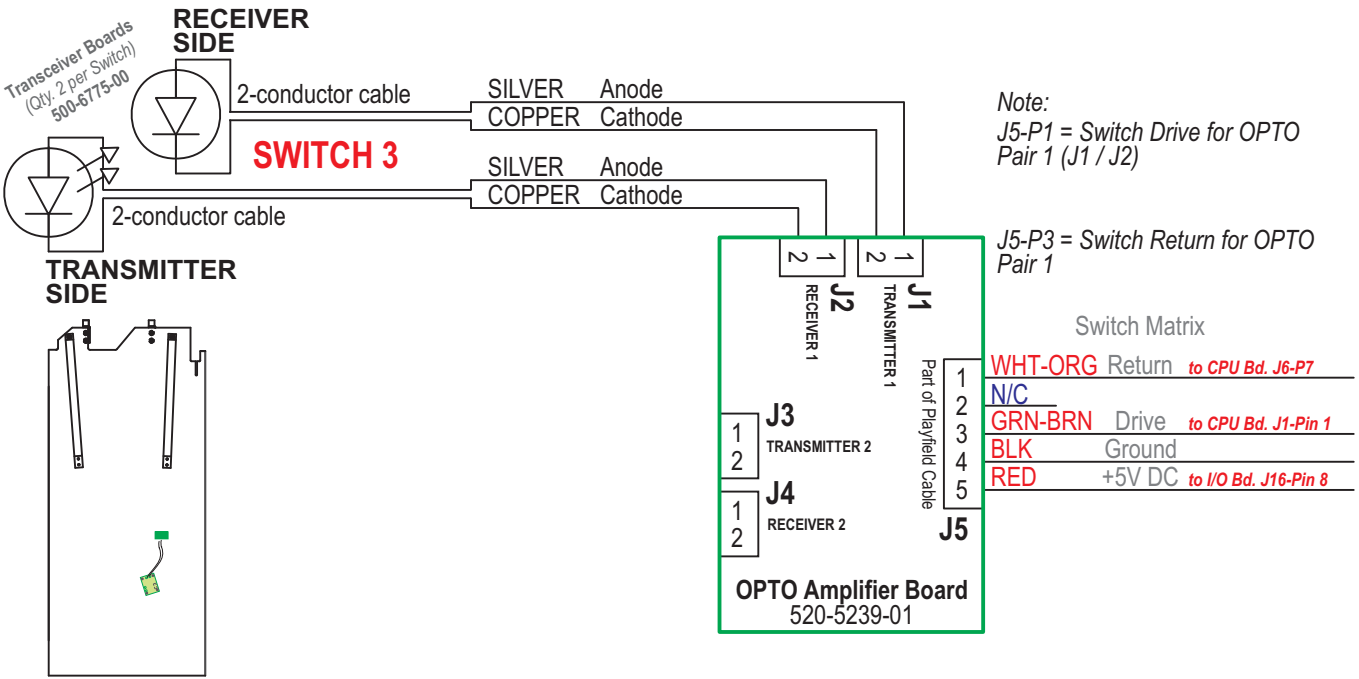

**Playfield OPTO Transmitter/Receiver Amplifier PCB (520-5239-01) Wiring (Game Specific)**  
**Board 3: OPTO Switches 60 [Skill Hole Made] & 61 [Ship Made] Location: Upper Right Ramp & Under Ship Left**

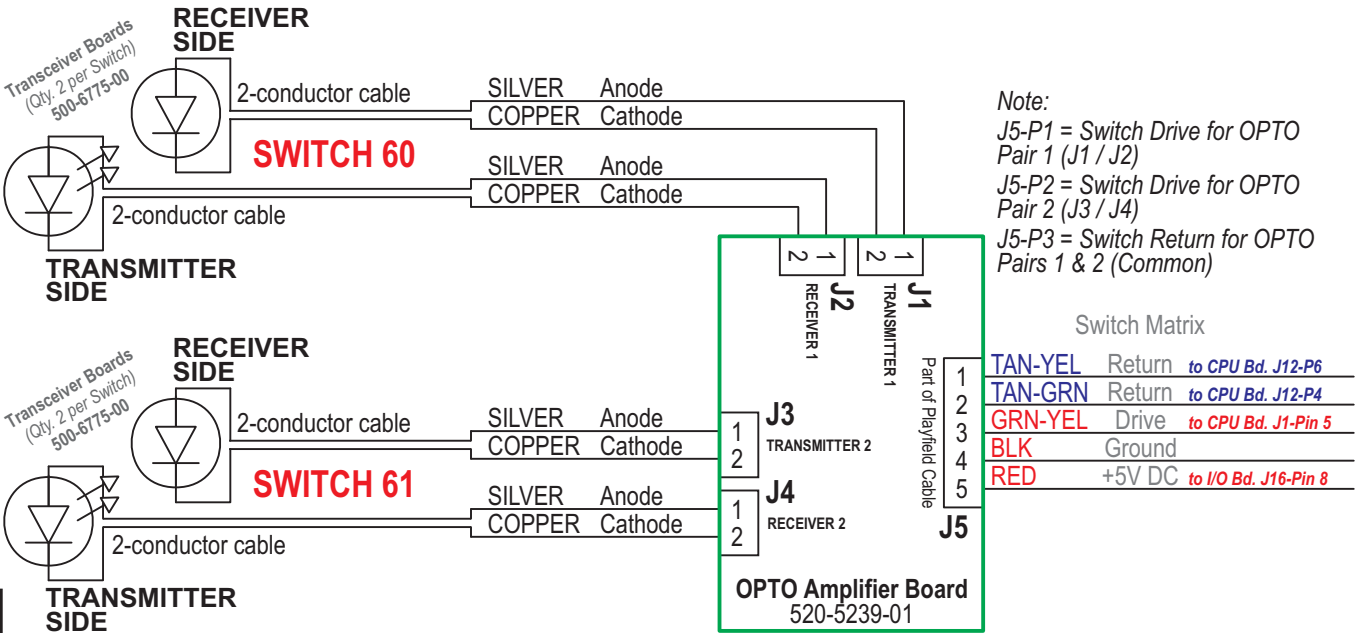

Sec. 5: PCBs

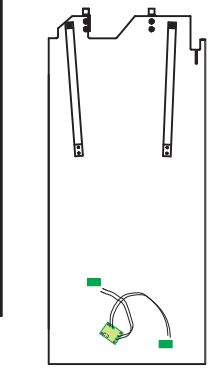

# Treasure Chest H-E-A-R-T LED PCB (520-5238-00) Schematic, Component Layout (opposite this page)

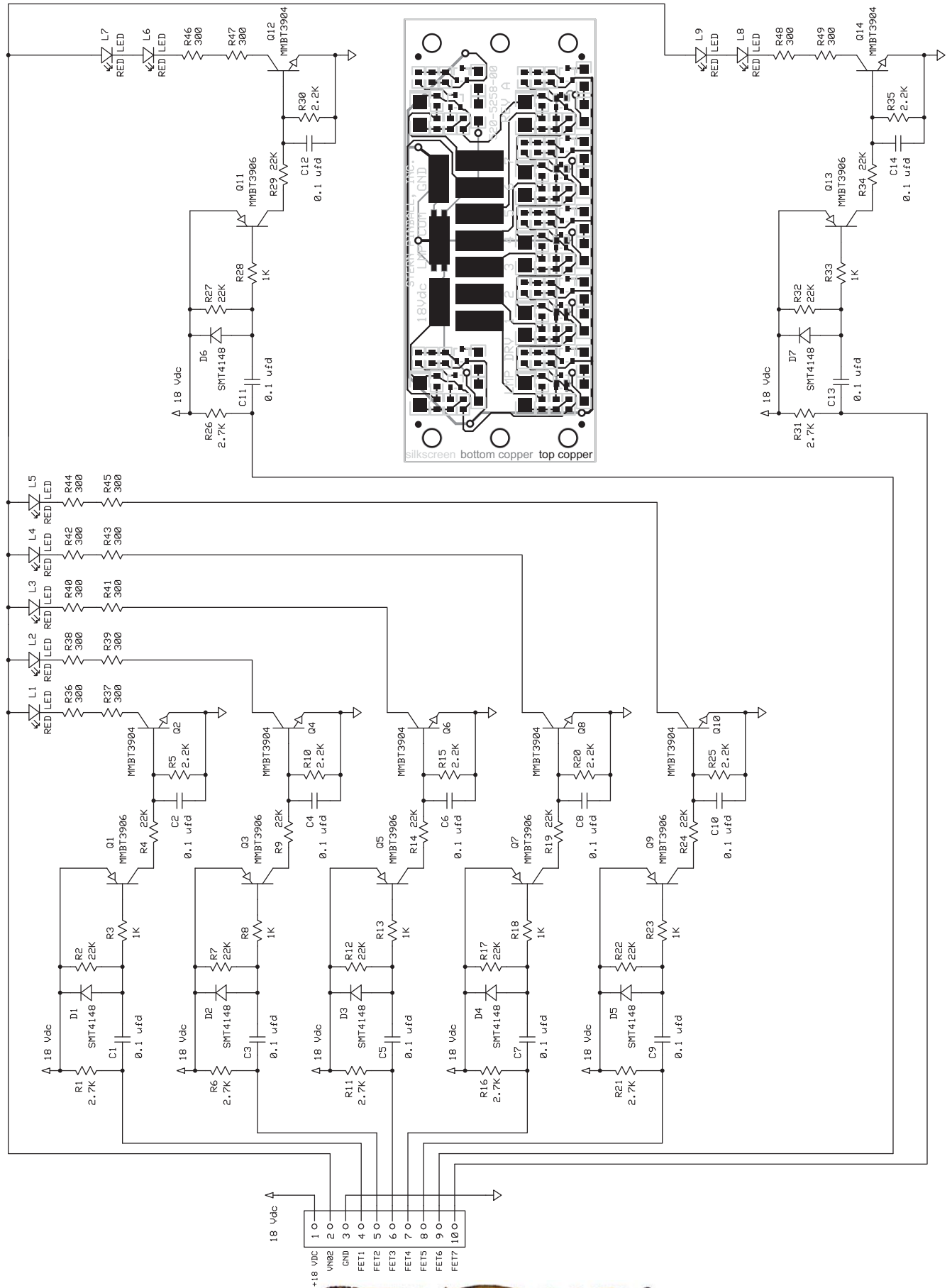

Treasure Chest H-E-A-R-T LED PCB (520-5238-00) Component Layout  
(Lamps 24, 32, 40, 48, 56, 64 & 72)

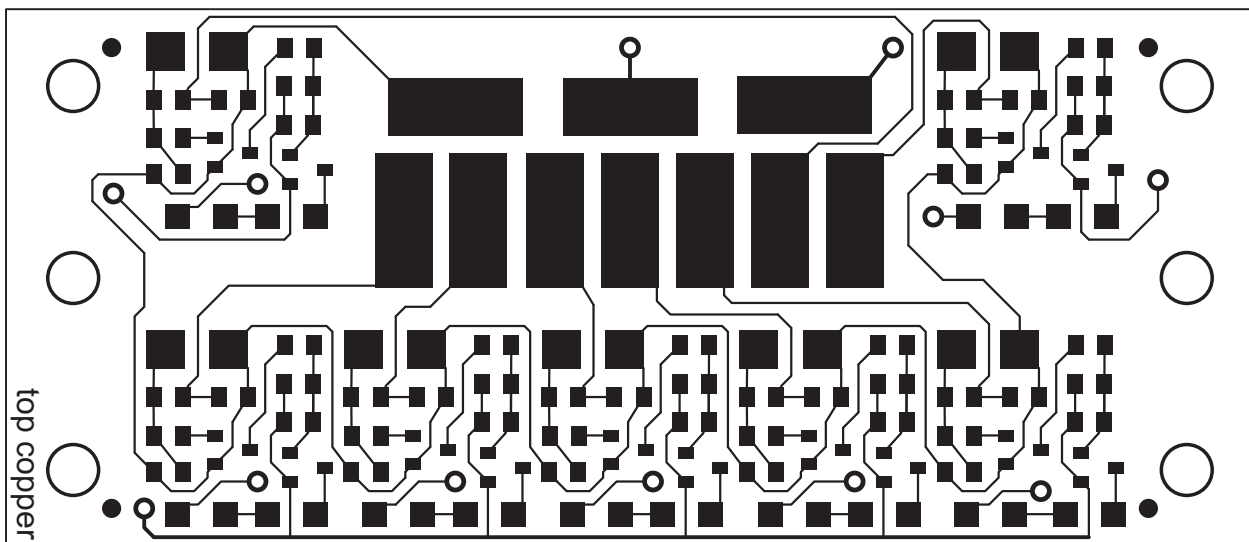
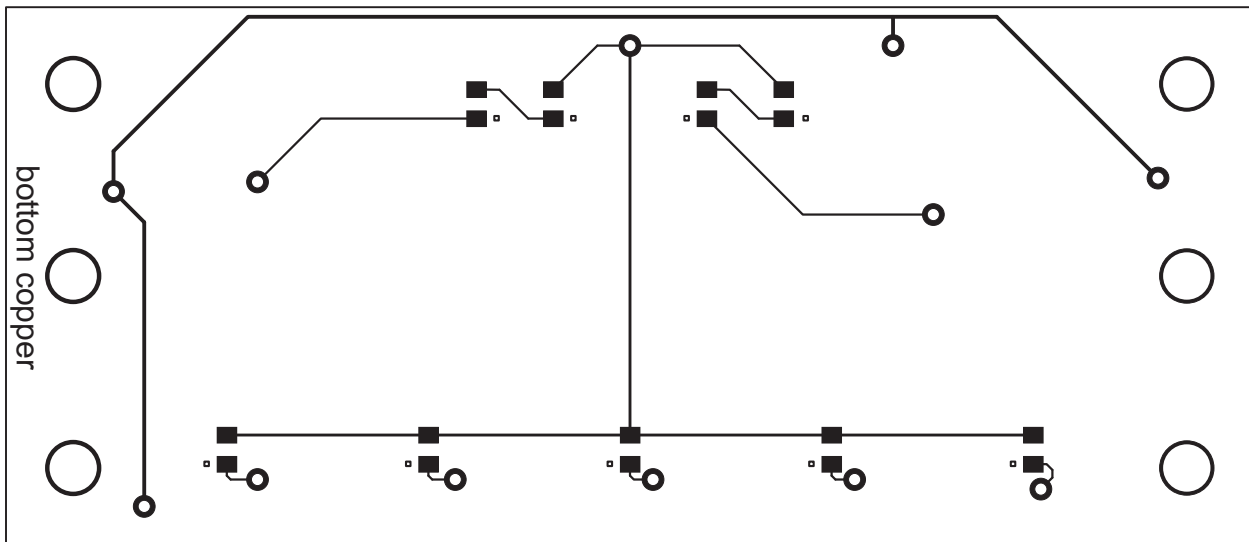
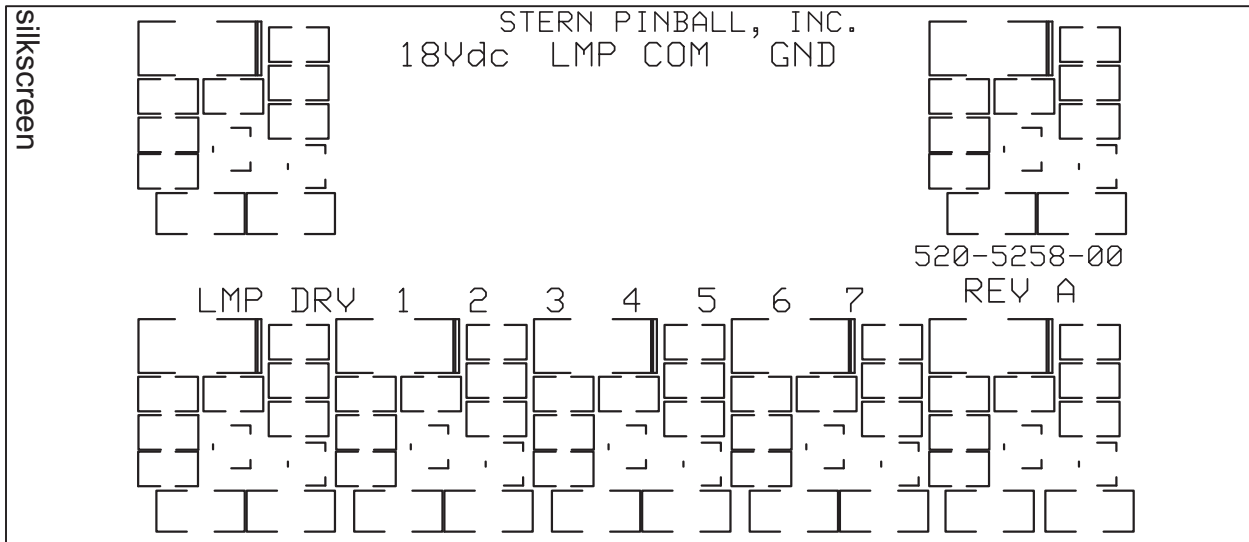

# Auxiliary (3X Transistor) Driver PCB (in Backbox) with the Coin/Ticket Meter and Ticket Dispenser Wiring Diagram

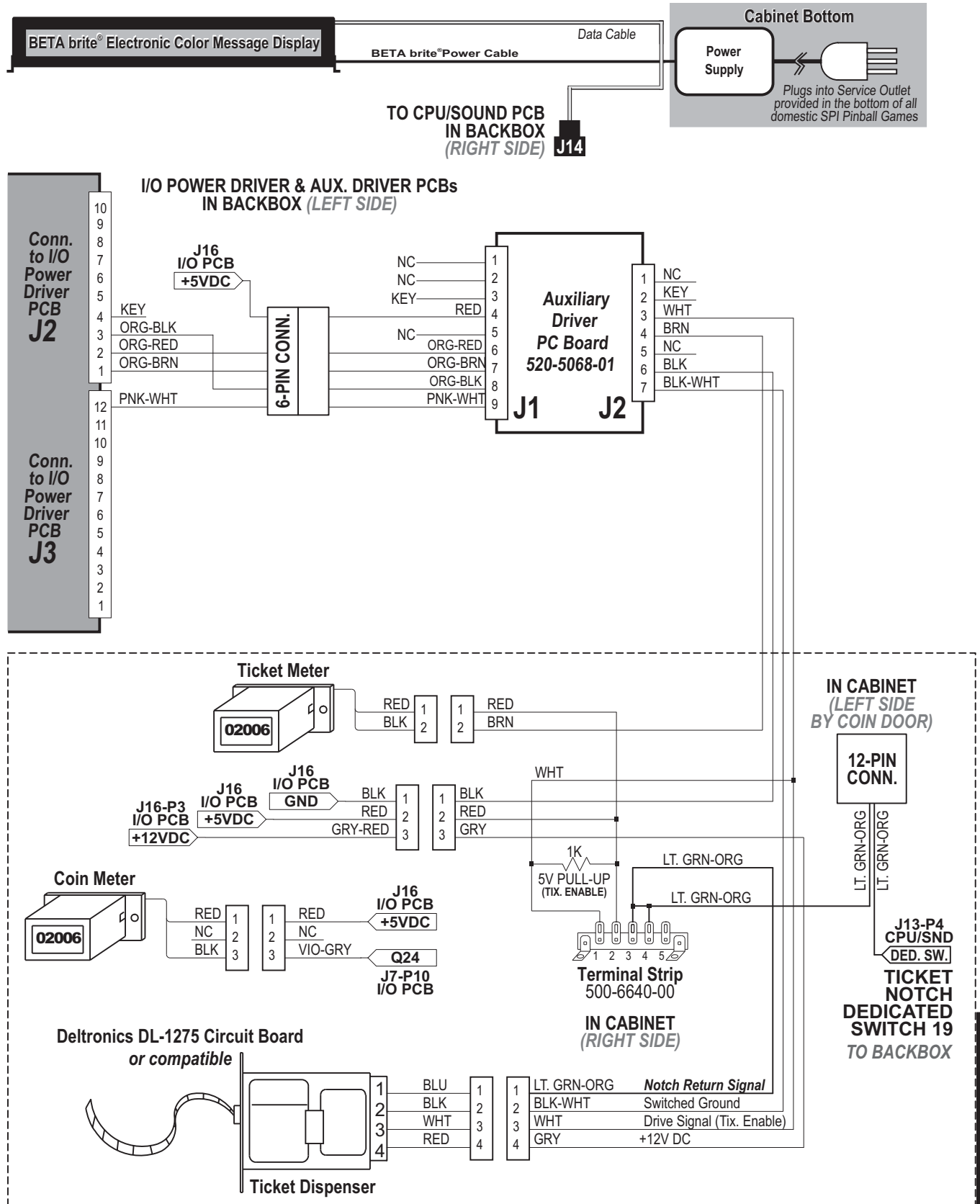

Sec. 5: PCBs



# Auxiliary (3X Transistor) Driver PCB Schematic

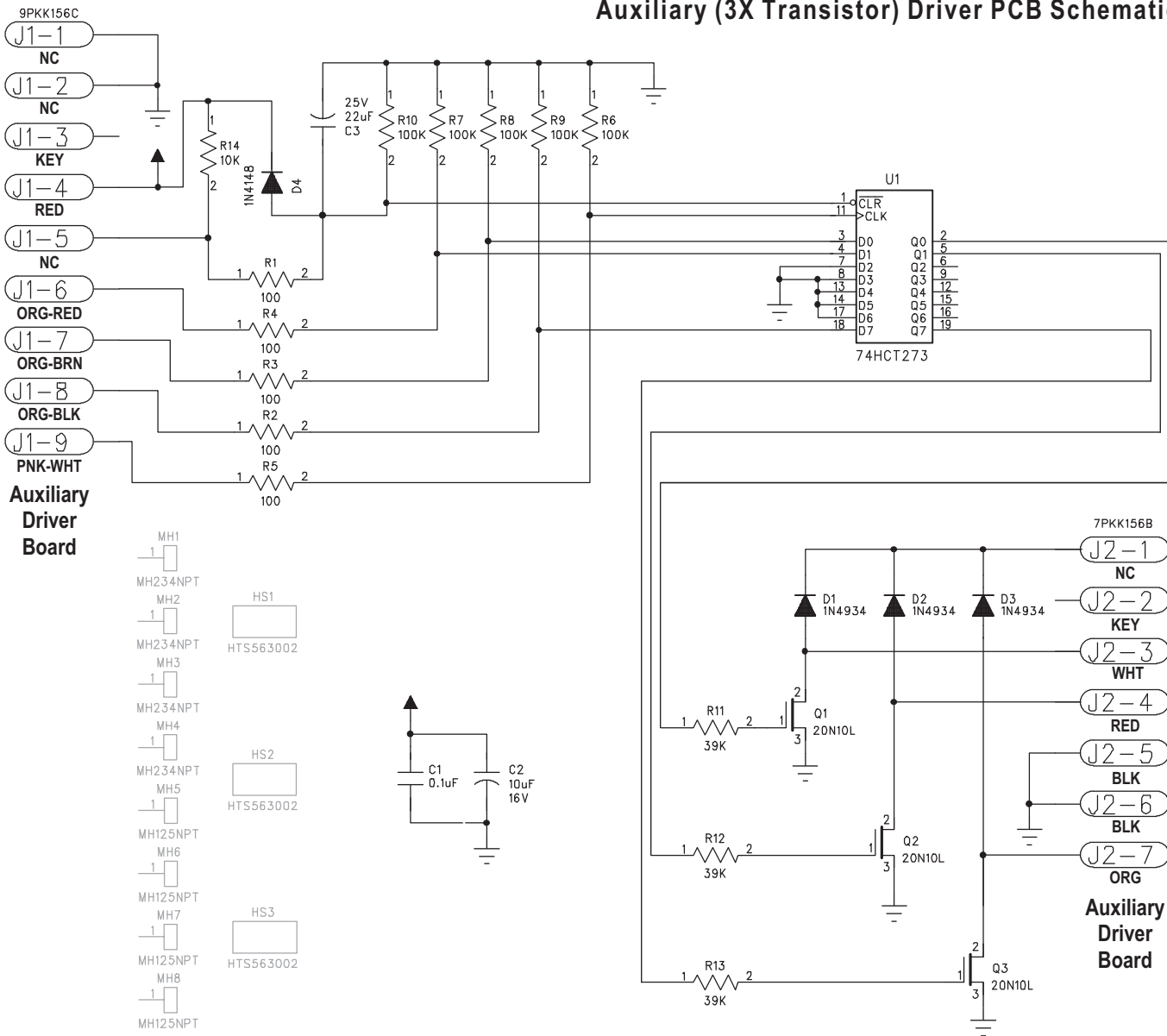

## Auxiliary (3X Transistor) Driver PCB Component Layout

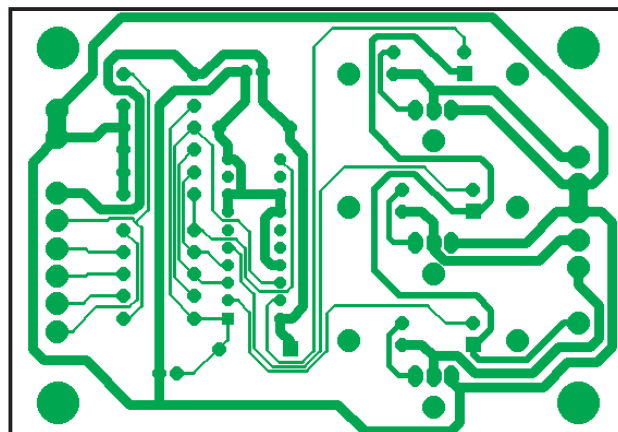
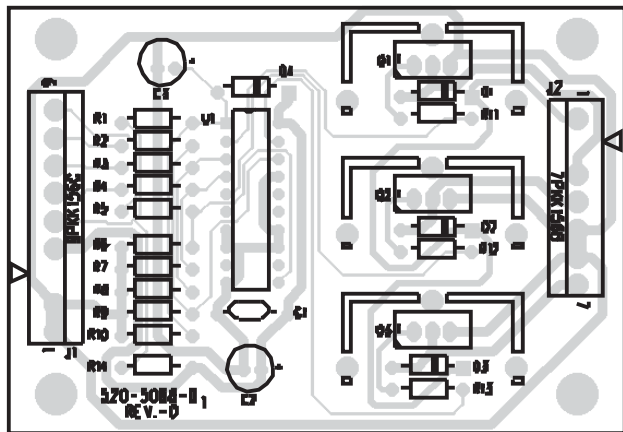

Sec. 5: PCBs

ITEM	QTY	PART NUMBER	REF-DESIGNATOR	DESCRIPTION
—	1	520-5068-01	Aux. / Solenoid Expander PCB (x3 Transistor)	Complete PCB Assembly



# Appendixes A through J

## Table of Contents for Appendixes

- **Appendix A : Pinball Game Firmware Table .....A1-A2**
  - ▶ [ White Star Board System and S.A.M. System Only\* ]
    - ▷ ... describes the ROM / Chip Size / Program & Raw Part Number / USA Version / Check Sum and CPU/Sound PCB I & II ROM locations for Games Apollo 13 — Grand Prix (White Star Games); World Poker Tour – current (S.A.M. Games).
- **Appendix B : Semi-Conductors / I.C.'s / Relays Cross-Reference Table ..... B1**
  - ▷ ...describes diodes and transistors with Source Number, SPI Part Number, NTE Number, ECG Number, Radio Shack Number & RCA Part Number (If applicable).
- **Appendix C : Production Start Date, Manual Part N<sup>o</sup>, ROM Size & Positions and Jumper W6 .. C1**
  - ▶ [ White Star Board System and S.A.M. System Only\* ]
    - ▷ ...provides the Production Start Date, Manual Part Number, ROM Position(s), and Jumpers Installed for Games Apollo 13 — Grand Prix (White Star Games); World Poker Tour – current (S.A.M. Games).
- **Appendix D : Board TYPE Table ..... D1-D2**
  - ▶ [ White Star Board System and S.A.M. System Only\* ]
    - ▷ ...provides the Flipper\*\*, I/O Power Driver, CPU/Sound, Display Power Supply, Dot Matrix Display, Display Controller, OPTOs and Misc. Board Part Numbers for Games Apollo 13 — Grand Prix (White Star Games); World Poker Tour – current (S.A.M. Games). \*\*Flipper Bd. with White Star Bd. System for A13 & Golden Eye only.)
- **Appendix E : Generic Coil Cross-Reference Guide & Flipper Coil Table .....E1-E2**
  - ▶ [ White Star Board System and S.A.M. System Only\* ]
    - ▷ ...provides the Coils used with Part Number and Gauge-Turns (of the coil) for Games Apollo 13 — Grand Prix (White Star Games); World Poker Tour – current (S.A.M. Games).
- **Appendix F : Motor Specification Table ..... F1-F2**
  - ▶ [ White Star Board System and S.A.M. System Only\* ]
    - ▷ ...provides all the Motor Function, Specifications and Part Number for Games Apollo 13 — Grand Prix (White Star Games); World Poker Tour – current (S.A.M. Games)..
- **Appendix G : Part Number Prefix Classification Codes ..... G1**
  - ▷ ...explains how our Part Numbers are developed to help sort parts easier.
- **Appendix H : Playfield Inserts (Plastic Light Covers) ..... H1**
  - ▷ ...gives a pictoral view with the name and Part Nr. of all the inserts used (with Color Code Chart).
- **Appendix I : Stand-Up Targets & Modular Stand-Up Targets ..... I1-I2**
  - ▷ ...gives a pictoral view with the name and Part Number of all the Single Stand-Up Targets used (with Color Code Chart).
- **Appendix J : Coin Cards (USA & International) ..... J1**
  - ▷ ...gives a pictoral view with the name and Part Number of all the current Coin Cards for USA, Canada, Euro and other International Countries. For all Coin Cards and/or free Coin Card files for download, visit our website : [www.sternpinball.com](http://www.sternpinball.com)



# APPENDIX A



## Pinball Game Firmware (White Star Board System\* Only) Table

See website for the latest International Code or Updated USA version / checksums

ROM	Chip Size	Program Part N <sup>o</sup>	USA ver. & Check Sum	Bd. Loc.	Raw Part N <sup>o</sup>
<b>Apollo 13 (Note 1)</b>					
Game ROM	(1M)	965-0208-00	A5.01   \$09FF	U210	960-5009-00
Sound	(512K)	965-0212-00	1.00   \$5244	U7	960-7001-02
Display	(4M)	965-0213-00	A5.00   \$B92B	ROM 0	960-5015-01
Voice 1	(4M)	965-0209-00	1.00   \$7FC7	U17	n/a (masked)
Voice 2	(4M)	965-0210-00	1.00   \$8E55	U21	n/a (masked)
Voice 3	(4M)	965-0211-00	1.00   \$08EE	U36	n/a (masked)
<b>Golden Eye (Note 1)</b>					
Game ROM	(1M)	965-0214-42	A4.04   \$3FFF	U210	960-5009-00
Sound	(512K)	965-0217-42	1.00   \$D615	U7	960-7001-02
Display	(4M)	965-0218-42	A4.00   \$E6ED	ROM 0	960-5015-01
Voice 1	(4M)	965-0215-42	1.00   \$3E32	U17	n/a (masked)
Voice 2	(4M)	965-0216-42	1.00   \$71F0	U21	n/a (masked)
<b>Twister (Note 2)</b>					
Game ROM	(1M)	965-0219-41	A4.05   \$E9FF	U210	960-5009-00
Sound	(512K)	965-0221-41	1.00   \$1FFF	U7	960-7001-02
Display	(4M)	965-0222-41	A4.00   \$FD01	ROM 0	960-5015-01
Voice 1	(4M)	965-0220-41	1.00   \$3650	U17	960-5015-01
Voice 2	(4M)	965-0223-41	1.00   \$9300	U21	960-5015-01
<b>ID4: Independence Day (Note 2)</b>					
Game ROM	(1M)	965-0224-45	A2.02   \$9CFF	U210	960-5009-00
Sound	(512K)	965-0227-45	1.00   \$222B	U7	960-7001-02
Display	(4M)	965-0228-45	A2.00   \$AB7	ROM 0	960-5015-01
Voice 1	(4M)	965-0225-45	1.00   \$3AF1	U17	960-5015-01
Voice 2	(4M)	965-0226-45	1.00   \$206E	U21	960-5015-01
<b>Space Jam (Note 2)</b>					
Game ROM	(1M)	965-0229-43	A3.00   \$E6FF	U210	960-5009-00
Sound	(512K)	965-0233-43	1.00   \$F1E7	U7	960-7001-02
Display	(4M)	965-0234-43	A3.00   \$0057	ROM 0	960-5015-01
Voice 1	(4M)	965-0230-43	1.00   \$DBA8	U17	960-5015-01
Voice 2	(4M)	965-0231-43	1.00   \$DDF1	U21	960-5015-01
Voice 3	(4M)	965-0232-43	1.00   \$F32A	U36	960-5015-01
<b>The Star Wars Trilogy - Special Edition (S.E.) (Note 2)</b>					
Game ROM	(1M)	965-0235-56	A4.03   \$5EFF	U210	960-5009-00
Sound	(512K)	965-0238-56	1.00   \$4A7D	U7	960-7001-02
Display	(4M)	965-0239-56	A4.00   \$8817	ROM 0	960-5015-01
Voice 1	(4M)	965-0236-56	1.00   \$E66B	U17	960-5015-01
Voice 2	(4M)	965-0237-56	1.00   \$8F54	U21	960-5015-01
<b>The Lost World: Jurassic Park (Note 2)</b>					
Game ROM	(1M)	965-0240-53	A2.02   \$C8FF	U210	960-5009-00
Sound	(512K)	965-0243-53	1.00   \$A35B	U7	960-7001-02
Display	(4M)	965-0244-53	A2.01   \$7F46	ROM 0	960-5015-01
Voice 1	(4M)	965-0241-53	1.00   \$1D27	U17	960-5015-01
Voice 2	(4M)	965-0242-53	1.00   \$8DA4	U21	960-5015-01
<b>The X-Files (Note 2)</b>					
Game ROM	(1M)	965-0245-46	A3.03   \$A2FF	U210	960-5009-00
Sound	(512K)	965-0248-46	1.00   \$65A8	U7	960-7001-02
Display	(4M)	965-0249-46	A3.00   \$66D0	ROM 0	960-5015-01
Voice 1	(4M)	965-0246-46	1.00   \$349D	U17	960-5015-01
Voice 2	(4M)	965-0247-46	1.00   \$629C	U21	960-5015-01
<b>Starship Troopers (Note 3)</b>					
Game ROM	(1M)	965-0250-59	A2.00   \$85FF	U210	960-5009-00
Sound	(512K)	965-0253-59	1.00   \$64B2	U7	960-7001-02
Display	(4M)	965-0254-59	A2.00   \$E77B	ROM 0	960-5015-01
Voice 1	(4M)	965-0251-59	1.00   \$152A	U17	960-5015-01
Voice 2	(4M)	965-0252-59	1.00   \$0291	U21	960-5015-01
Voice 3	(4M)	965-0255-59	1.00   \$95A7	U36	960-5015-01
<b>Viper Night Drivin' (Note 4)</b>					
Game ROM	(1M)	965-0266-35	A2.01   \$C5FF	U210	960-5009-00
Sound	(512K)	965-0271-35	1.00   \$4DF8	U7	960-7001-02
Display	(4M)	965-0272-35	A2.01   \$C17D	ROM 0	960-5015-01
Voice 1	(4M)	965-0267-35	1.00   \$9018	U17	960-5015-01
Voice 2	(4M)	965-0268-35	1.00   \$2157	U21	960-5015-01
Voice 3	(4M)	965-0269-35	1.00   \$B5A6	U36	960-5015-01
Voice 4	(4M)	965-0270-35	1.00   \$D01E	U37	960-5015-01
<b>Lost In Space (Note 4)</b>					
Game ROM	(1M)	965-0282-60	A1.01   \$B2FF	U210	960-5009-00
Sound	(512K)	965-0287-60	1.00   \$A6AF	U7	960-7001-02
Display	(4M)	965-0288-60	A1.02   \$32AB	ROM 0	960-5015-01
Voice 1	(4M)	965-0283-60	1.00   \$4391	U17	960-5015-01
Voice 2	(4M)	965-0284-60	1.00   \$8215	U21	960-5015-01
Voice 3	(4M)	965-0285-60	1.00   \$5B32	U36	960-5015-01
Voice 4	(4M)	965-0286-60	1.00   \$8971	U37	960-5015-01
<b>Godzilla (Note 4)</b>					
Game ROM	(1M)	965-0289-40	A2.05   \$B1FF	U210	960-5009-00
Sound	(512K)	965-0294-40	1.00   \$0CC9	U7	960-7001-02
Display	(4M)	965-0295-40	A2.00   \$C929	ROM 0	960-5015-01
Voice 1	(4M)	965-0290-40	1.00   \$0D75	U17	960-5015-01
Voice 2	(4M)	965-0291-40	1.00   \$CCCF	U21	960-5015-01
Voice 3	(4M)	965-0292-40	1.00   \$227F	U36	960-5015-01
Voice 4	(4M)	965-0293-40	1.00   \$DB69	U37	960-5015-01
<b>South Park (Notes 4, 5)</b>					
Game ROM	(1M)	965-0301-71	A1.03   \$58FF	U210	960-5009-00
Sound	(512K)	965-0306-71	1.00   \$1286	U7	960-7001-02
Display	(4M)	965-0307-71	A1.01   \$166F	ROM 0	960-5015-01
Voice 1	(8M)	965-0302-71	1.00   \$7BF8	U17	960-5016-00
Voice 2	(8M)	965-0303-71	1.00   \$9CCC	U21	960-5016-00
Voice 3	(8M)	965-0304-71	1.00   \$ADD9	U36	960-5016-00
Voice 4	(8M)	965-0305-71	1.00   \$6659	U37	960-5016-00

ROM	Chip Size	Program Part N <sup>o</sup>	USA Ver. & Check Sum	Bd. Loc.	Raw Part N <sup>o</sup>
<b>Harley-Davidson® (Notes 4, 5, 6) Original (1999-2001)</b>					
Game ROM	(1M)	965-0319-67	A1.03   \$3EFF	U210	960-5009-00
Sound	(512K)	965-0320-67	1.00   \$F4FF	U7	960-7001-02
Display	(4M)	965-0321-67	A1.04   \$FC7C	ROM 0	960-5015-01
Voice 1	(8M)	965-0322-67	1.00   \$CD26	U17	960-5016-00
Voice 2	(8M)	965-0323-67	1.00   \$3936	U21	960-5016-00
Voice 3	(8M)	965-0324-67	1.00   \$FB72	U36	960-5016-00
Voice 4	(4M)	965-0325-67	1.00   \$6100	U37	960-5015-01
<b>► Harley-Davidson® (Notes 4, 5, 6, 8) 2nd Edition (2002-2003)</b>					
Game ROM	(1M)	965-0319-67A	A1.08   \$23FF	U210	960-5009-00
Display	(4M)	965-0321-67A	A1.05   \$B594	ROM 0	960-5015-01
<b>► Harley-Davidson® (Notes 4, 5, 6, 8) 3rd Edition (2004)</b>					
Game ROM	(1M)	965-0319-87	A4.00   \$1CFF	U210	960-5009-00
Display	(4M)	965-0321-87	A4.00   \$F4FF	U5	960-5015-01
<b>Striker Xtreme (Notes 4, 5)</b>					
Game ROM	(1M)	965-0326-68	A1.03   \$E4FF	U210	960-5009-00
Sound	(512K)	965-0327-68	1.00   \$3BCA	U7	960-7001-02
Display	(4M)	965-0328-68	A1.03   \$1957	ROM 0	960-5015-01
Voice 1	(8M)	965-0329-68	1.00   \$482A	U17	960-5016-00
Voice 2	(8M)	965-0330-68	1.00   \$7312	U21	960-5016-00
Voice 3	(8M)	965-0331-68	1.00   \$DE2F	U36	960-5016-00
Voice 4	(8M)	965-0332-68	1.00   \$C508	U37	960-5016-00
<b>NFL (Notes 4, 5) Not on CD-R or Website: Code through Distributor Only.</b>					
Game ROM	(1M)	965-0339-73	A1.00   \$D2FF	U210	960-5009-00
Sound	(512K)	965-0340-73	1.00   U7	960-7001-02	
Display	(4M)	965-0341-73	A1.01   \$845A	ROM 0	960-5015-01
Voice 1	(8M)	965-0342-73	1.00   U17	960-5016-00	
Voice 2	(8M)	965-0343-73	1.00   U21	960-5016-00	
Voice 3	(8M)	965-0344-73	1.00   U36	960-5016-00	
Voice 4	(8M)	965-0345-73	1.00   U37	960-5016-00	
<b>Sharkey's Shootout (Notes 4, 5)</b>					
Game ROM	(1M)	965-0333-72	A2.11   \$49FF	U210	960-5009-00
Sound	(512K)	965-0333-72	1.01   \$9796	U7	960-7001-02
Display	(4M)	965-0335-72	A2.01   \$6C33	ROM 0	960-5015-01
Voice 1	(8M)	965-0336-72	1.00   \$58EA	U17	960-5016-00
Voice 2	(8M)	965-0337-72	1.00   \$272B	U21	960-5016-00
Voice 3	(8M)	965-0338-72	1.00   \$41AE	U36	960-5016-00
<b>High Roller Casino (Notes 4, 5)</b>					
Game ROM	(1M)	965-0346-65	A3.00   \$90FF	U210	960-5009-00
Sound	(512K)	965-0347-65	1.00   \$581C	U7	960-7001-02
Display	(4M)	965-0348-65	A3.00   \$74B3	ROM 0	960-5015-01
Voice 1	(8M)	965-0349-65	1.00   \$E12D	U17	960-5016-00
Voice 2	(8M)	965-0350-65	1.00   \$38F4	U21	960-5016-00
Voice 3	(8M)	965-0351-65	1.00   \$1B54	U36	960-5016-00
Voice 4	(8M)	965-0352-65	1.00   \$D720	U37	960-5016-00
<b>Austin Powers™ (Notes 4, 5)</b>					
Game ROM	(1M)	965-0353-74	A3.02   \$5DFF	U210	960-5009-00
Sound	(512K)	965-0354-74	1.00   \$D47B	U7	960-7001-02
Display	(4M)	965-0355-74	A3.00   \$6A3A	ROM 0	960-5015-01
Voice 1	(8M)	965-0356-74	1.00   \$D2B9	U17	960-5016-00
Voice 2	(8M)	965-0357-74	1.00   \$9E75	U21	960-5016-00
Voice 3	(8M)	965-0358-74	1.00   \$51F3	U36	960-5016-00
Voice 4	(8M)	965-0359-74	1.00   \$0AE5	U37	960-5016-00
<b>MONOPOLY® (Notes 4, 5)</b>					
Game ROM	(1M)	965-0360-75	A3.20   \$07FF	U210	960-5009-00
Sound	(512K)	965-0361-75	1.00   \$8C18	U7	960-7001-02
Display	(4M)	965-0362-75	A3.01   \$A381	ROM 0	960-5015-01
Voice 1	(8M)	965-0363-75	1.00   \$35E6	U17	960-5016-00
Voice 2	(8M)	965-0364-75	1.00   \$B35A	U21	960-5016-00
Voice 3	(8M)	965-0365-75	1.00   \$8A9F	U36	960-5016-00
<b>Playboy (Notes 4, 5, 7)</b>					
Game ROM	(1M)	965-0367-76	A5.00   \$7DFF	U210	960-5009-00
Sound	(512K)	965-0368-76	1.02   \$E7C2	U7	960-7001-02
Display	(4M)	965-0369-76	A5.00   \$A5FF	ROM 0	960-5015-01
Voice 1	(8M)	965-0370-76	1.00   \$9ABE	U17	960-5016-00
Voice 2	(8M)	965-0371-76	1.00   \$9F34	U21	960-5016-00
Voice 3	(8M)	965-0372-76	1.00   \$374B	U36	960-5016-00
Voice 4	(8M)	965-0373-76	1.00   \$237A	U37	960-5016-00
<b>RollerCoaster Tycoon™ (Notes 4, 5, 7)</b>					
Sound	(512K)	965-0374-78	1.00   \$F663	U7	960-7001-02
Game ROM	(1M)	965-0375-78	A7.02   \$55FF	U210	960-5009-00
Voice 1	(8M)	965-0377-78	1.00   \$3C4A	U17	96





# APPENDIX A

## Pinball Game Firmware (White Star Board System\* & S.A.M. System\*\* Only) Table



See website for the latest International Code or Updated USA version / checksums

ROM	Chip Size	Program Part N <sup>o</sup>	USA Ver. & Check Sum	Bd. Loc.	Raw Part N <sup>o</sup>
<b>Ripley's Believe It or Not!® (Notes 7, 8)</b>					
Sound	(512K)	965-0408-81	1.00   \$D93D	U7	960-7001-02
Game ROM	(1M)	965-0409-81	<b>A3.20</b>   <b>\$43FF</b>	<b>U210</b>	960-5009-00
Voice 1	(8M)	965-0410-81	1.00	\$067B U17	960-5016-00
Voice 2	(8M)	965-0411-81	1.00	\$C8B8 U21	960-5016-00
Voice 3	(8M)	965-0412-81	1.00	\$64C2 U36	960-5016-00
Voice 4	(8M)	965-0413-81	1.00	\$5341 U37	960-5016-00
Display	(4M)	965-0414-81	<b>A3.00</b>   <b>\$DE4B</b>	<b>U5</b> DC PCB	960-5015-01
<b>Elvis® (Notes 7, 8)</b>					
Sound	(512K)	965-0415-84	1.00   \$8CD2	U7	960-7001-02
Game ROM	(1M)	965-0416-84	<b>A5.00</b>   <b>\$50FF</b>	<b>U210</b>	960-5009-00
Voice 1	(8M)	965-0417-84	1.00	\$538D U17	960-5016-00
Voice 2	(8M)	965-0418-84	1.00	\$8BCD U21	960-5016-00
Voice 3	(8M)	965-0419-84	1.00	\$60F8 U36	960-5016-00
Voice 4	(8M)	965-0420-84	1.00	\$14D8 U37	960-5016-00
Display	(4M)	965-0421-84	<b>A5.00</b>   <b>\$A1F6</b>	<b>U5</b> DC PCB	960-5015-01
<b>The Sopranos<sup>SM</sup> (Notes 7, 8)</b>					
Sound	(512K)	965-0422-85	4.00   \$9B5A	U7	960-7001-02
Game ROM	(1M)	965-0423-85	<b>A5.00</b>   <b>\$5BFF</b>	<b>U210</b>	960-5009-00
Voice 1	(8M)	965-0424-85	3.00	\$F01E U17	960-5016-00
Voice 2	(8M)	965-0425-85	1.04	\$C14C U21	960-5016-00
Voice 3	(8M)	965-0426-85	1.04	\$47A3 U36	960-5016-00
Voice 4	(8M)	965-0427-85	1.04	\$ADCD U37	960-5016-00
Display	(4M)	965-0428-85	<b>A5.00</b>   <b>\$B4BB</b>	<b>U5</b> DC PCB	960-5015-01
<b>NASCAR® (Notes 7, 8)</b>					
Sound	(512K)	965-0429-86	2.00   \$32B3	U7	960-7001-02
Game ROM	(1M)	965-0430-86	<b>A4.50</b>   <b>\$39FF</b>	<b>U210</b>	960-5009-00
Voice 1	(8M)	965-0431-86	2.00	\$CFFB U17	960-5016-00
Voice 2	(8M)	965-0432-86	2.00	\$22C0 U21	960-5016-00
Voice 3	(8M)	965-0433-86	2.00	\$5FC8 U36	960-5016-00
Voice 4	(8M)	965-0434-86	2.00	\$2902 U37	960-5016-00
Display	(4M)	965-0435-86	<b>A4.00</b>   <b>\$92BD</b>	<b>U5</b> DC PCB	960-5015-01
<b>Grand Prix (Notes 7, 8)</b>					
Sound	(512K)	965-0429-91	V1.00   \$6F89	U7	960-7001-02
Game ROM	(1M)	965-0430-91	<b>A4.50</b>   <b>\$5EFF</b>	<b>U210</b>	960-5009-00
Voice 1	(8M)	965-0431-91	1.00	\$C0E2 U17	960-5016-00
Voice 2	(8M)	965-0432-91	1.00	\$F4C6 U21	960-5016-00
Voice 3	(8M)	965-0433-91	1.00	\$057D U36	960-5016-00
Voice 4	(8M)	965-0434-91	1.00	\$2646 U37	960-5016-00
Display	(4M)	965-0435-91	<b>A4.00</b>   <b>\$DA8E</b>	<b>U5</b> DC PCB	960-5015-01
<b>[NDSE] (Notes 7, 8) <i>Call for more info if code update required.</i></b>					
Sound	(512K)	965-0436-97		U7	960-7001-02
Game ROM	(1M)	965-0437-97		<b>U210</b>	960-5009-00
Voice 1	(8M)	965-0438-97		U17	960-5016-00
Voice 2	(8M)	965-0439-97		U21	960-5016-00
Voice 3	(8M)	965-0440-97		U36	960-5016-00
Voice 4	(8M)	965-0441-97		U37	960-5016-00
Display	(4M)	965-0442-97		<b>U5</b> DC PCB	960-5015-01

\*\* GAMES BELOW THIS LINE / NEXT COLUMN ARE S.A.M. SYSTEM GAMES

TO ORDER MEMORY STICK WITH GAME FILES FROM YOUR DISTRIBUTOR, USE SPI PART NUMBER 970-0128-00 & INCLUDE THE GAME NAME / LANGUAGE FILE(S) DESIRED.

<b>World Poker Tour™ Pinball (WPT) (Notes 7, 9)</b>					
Boot B-02	(8M)	965-BOOT-SAM	1.04   \$7E62	U9	960-5016-00 unprogrammed
Memory Stick 128MB (970-0128-00)		Version		System	Bin Files:
English + Spanish		1.12AL		1.17+	WPT0112AL.bin
English Only		1.12A		1.17+	WPT0112A.bin
English + French		1.12AF		1.17+	WPT0112AF.bin
French Only		1.12F		1.17+	WPT0112F.bin
German + French		1.12GF		1.17+	WPT0112GF.bin
German Only		1.12G		1.17+	WPT0112G.bin
English + Italian		1.12AI		1.17+	WPT0112AI.bin
Italian Only		1.12I		1.17+	WPT0112I.bin

NOTE: THE TYPICAL SIZE PER UNZIPPED BIN FILE IS 25MB – 30MB+/-

<b>The Simpsons™ Kooky Carnival Redemption (Note 9)</b>					
Boot B-02	(8M)	965-BOOT-SAM	1.04   \$7E62	U9	960-5016-00 unprogrammed
Memory Stick 128MB (970-0128-00)		Version		Bin Files:	
English Only		1.05		SKC0105.bin	
English New Jersey Only		0.09NJ		SKC0090NJ.bin	

NOTE: THE TYPICAL SIZE PER UNZIPPED BIN FILE IS 5.5MB +/-

<b>©Disney's Pirates of the Caribbean Pinball (POTC) (Notes 7, 9)</b>					
Boot B-02	(8M)	965-BOOT-SAM	1.06   \$2014	U9	960-5016-00 unprogrammed
Memory Stick 128MB (970-0128-00)		Version		System	Bin Files:
English + Spanish		1.15AS		1.17+	POTC115AS.bin
English + French		1.15AF		1.17+	POTC115AF.bin
German + French		1.15GF		1.17+	POTC115GF.bin
English + Italian		1.15AI		1.17+	POTC115AI.bin

NOTE: THE TYPICAL SIZE PER UNZIPPED BIN FILE IS 25MB – 30MB+/-

<b>Family Guy™ Pinball (FG) (Notes 7, 9)</b>					
Boot B-02	(8M)	965-BOOT-SAM	2.09   \$10A3	U9	960-5016-00 unprogrammed
Memory Stick 128MB (970-0128-00)		Version		System	Bin Files:
English + Spanish		10.00AL		1.23+	FG1000AL.bin
English + French		10.00AF		1.23+	FG1000AF.bin
English + German		10.00AG		1.23+	FG1000GF.bin
English + Italian		10.00AI		1.23+	FG1000AI.bin

NOTE: THE TYPICAL SIZE PER UNZIPPED BIN FILE IS 25MB – 30MB+/-

<b>Spider-Man™ Pinball (S-M) (Notes 7, 9)</b>					
Boot B-02	(8M)	965-BOOT-SAM	2.10   \$F625	U9	960-5016-00 unprogrammed
Memory Stick 128MB (970-0128-00)		Version		System	Bin Files:
English + Spanish		1.3ES		1.27+	spd_1_30_es.bin
English + French		1.3EF		1.27+	spd_1_30_ef.bin
German + French		1.3GF		1.27+	spd_1_30_gf.bin
English + Italian		1.3EI		1.27+	spd_1_30_ei.bin

NOTE: THE TYPICAL SIZE PER UNZIPPED BIN FILE IS 25MB – 30MB+/-

### footnotes:

- 1 ROMs on CPU/Sound Bd.: 520-5136-00 (Stereo) & Display Cont. Bd.: 520-5055-01
- 2 ROMs on CPU/Sound Bd.: 520-5136-10 (Mono) & Display Cont. Bd.: 520-5055-01
- 3 ROMs on CPU/Sound Board: 520-5136-15\* (Mono) (\*FCC 11-97) & Display Controller Board: 520-5055-02\* (\*FCC 11-97)



# APPENDIX A

## Pinball Game Firmware Table

EPROM	Chip Size	Program Part N <sup>o</sup>	USA Ver.	Bd. Loc.	Raw Part N <sup>o</sup>	EPROM	Chip Size	Program Part N <sup>o</sup>	USA Ver.	Bd. Loc.	Raw Part N <sup>o</sup>
<b>Laser War</b>						<b>Lethal Weapon 3</b>					
CPU	(256K)	965-0004-00	LWAR.C5	C5	960-5007-00	CPU	(512K)	965-0082-00	A2.08	C5	960-7001-02
Sound (old)	(256K)	965-0005-00		J5	960-5007-00	Voice 1	(2M)	965-0083-00		U17	960-5010-00
Sound (old)	(256K)	965-0006-00		J6	960-5007-00	Voice 2	(2M)	965-0084-00		U21	960-5010-00
Sound (old)	(256K)	965-0007-00		J7	960-5007-00	Sound	(256K)	965-0085-00		U7	960-5007-00
			- OR -			Display	(2M)	965-0086-00	A2.06	ROM 0	960-5010-00
Sound	(256K)	965-0008-00		7F	960-5007-00	Display	(2M)	965-0087-00	A2.06	ROM 1	960-5010-00
Sound 1	(512K)	965-0009-00		6F	960-7001-02				-OR-		
Sound 2	(512K)	965-0010-00		4F	960-7001-02	Display	(4M)	965-0087-04	A2.06	ROM 0	960-5015-00
									(Used on Display PCB 520-5055-01)		
<b>Secret Service</b>						<b>Star Wars</b>					
CPU	(256K)	965-0011-00	A4-6	B5	960-5007-00	CPU	(512K)	965-0119-00	A1.03	C5	960-7001-02
CPU	(256K)	965-0012-00	A4-6	C5	960-5007-00	Voice 0	(4M)	965-0132-00		U17	960-5015-00
Voice 1	(512K)	965-0014-00		6F	960-7001-02	Voice 1	(2M)	965-0133-00		U21	960-5010-00
Voice 2	(512K)	965-0015-00		4F	960-7001-02	Sound	(256K)	965-0131-00		U7	960-5007-00
Sound	(256K)	965-0013-00		7F	960-5007-00	Display	(2M)	965-0120-00	A1.04	ROM 0	960-5010-00
						Display	(2M)	965-0121-00	A1.04	ROM 1	960-5010-00
									(Used on Display PCB 520-5055-00)		
<b>Torpedo Alley</b>						<b>Rocky &amp; Bullwinkle &amp; Friends</b>					
CPU	(256K)	965-0016-00	A2-1	B5	960-5007-00	CPU	(512K)	965-0138-00	A1.30	C5	960-7001-02
CPU	(256K)	965-0017-00	A2-1	C5	960-5007-00	Voice 0	(4M)	965-0139-00		U17	960-5015-00
Voice 1	(512K)	965-0018-00		6F	960-7001-02	Voice 1	(2M)	965-0140-00		U21	960-5010-00
Voice 2	(512K)	965-0019-00		4F	960-7001-02	Sound	(256K)	965-0141-00		U7	960-5007-00
Sound	(256K)	965-0018-00		7F	960-5007-00	Display	(4M)	965-0142-00	A1.30	ROM 0	960-5015-00
									-OR-		
									(Used on Display PCB 520-5055-01)		
<b>Time Machine</b>						<b>Jurassic Park</b>					
CPU	(128K)	965-0021-00	A2-4	B5	960-5006-00	CPU	(512K)	965-0143-00	A5.13	C5	960-7001-02
CPU	(256K)	965-0022-00	A2-4	C5	960-5007-00	Voice 0	(4M)	965-0144-00		U17	960-5015-00
Voice 1	(512K)	965-0024-00		6F	960-7001-02	Voice 1	(2M)	965-0145-00		U21	960-5010-00
Voice 2	(512K)	965-0025-00		4F	960-7001-02	Sound	(256K)	965-0146-00		U7	960-5007-00
Sound	(256K)	965-0023-00		7F	960-5007-00	Display	(4M)	965-0147-00	A5.10	ROM 0	960-5015-00
<b>Playboy 35th Anniversary</b>						<b>Last Action Hero</b>					
CPU	(256K)	965-0046-00	A2-4	B5	960-5007-00	CPU	(512K)	965-0148-00	A1.12	C5	960-7001-02
CPU	(256K)	965-0047-00	A2-4	C5	960-5007-00	Voice 0	(4M)	965-0149-00		U17	960-5015-00
Voice 1	(512K)	965-0049-00		6F	960-7001-02	Voice 1	(2M)	965-0150-00		U21	960-5010-00
Voice 2	(512K)	965-0050-00		4F	960-7001-02	Sound	(256K)	965-0151-00		U7	960-5007-00
Sound	(256K)	965-0048-00		7F	960-5007-00	Display	(4M)	965-0152-00	A1.06	ROM 0	960-5015-00
<b>ABC Monday Night Football</b>						<b>Tales from the Crypt</b>					
CPU	(128K)	965-0031-00	A2-7	B5	960-5006-00	CPU	(512K)	965-0157-00	A3.03	C5	960-7001-02
CPU	(256K)	965-0032-00	A2-7	C5	960-5007-00	Voice 0	(4M)	965-0158-00		U17	960-5015-00
Voice 1	(512K)	965-0034-00		6F	960-7001-02	Voice 1	(2M)	965-0159-00		U21	960-5010-00
Voice 2	(512K)	965-0035-00		4F	960-7001-02	Sound	(256K)	965-0160-00		U7	960-5007-00
Sound	(256K)	965-0033-00		7F	960-5007-00	Display	(4M)	965-0161-00	A3.01	ROM 0	960-5015-00
<b>Robocop</b>						<b>The Who's Tommy</b>					
CPU	(256K)	965-0036-00	A3-4	B5	960-5007-00	CPU	(512K)	965-0162-00	A4.00	C5	960-7001-02
CPU	(256K)	965-0037-00	A3-4	C5	960-5007-00	Voice 1	(4M)	965-0163-00		U17	960-5015-00
Voice 1	(512K)	965-0039-00		6F	960-7001-02	Voice 2	(4M)	965-0166-00		U21	960-5010-00
Voice 2	(512K)	965-0040-00		4F	960-7001-02	Voice 3	(4M)	965-0167-00		U36	960-5015-00
Sound	(256K)	965-0038-00		7F	960-5007-00	Voice 4	(4M)	965-0168-00		U37	960-5015-00
						Sound	(512K)	965-0164-00		U7	960-7001-02
						Display	(4M)	965-0163-00	A4.00	ROM 0	960-5015-00
<b>Phantom of the Opera</b>						<b>WWF Royal Rumble</b>					
CPU	(128K)	965-0026-00	A3-2	B5	960-5006-00	CPU	(512K)	965-0169-00	A1.06	C5	960-7001-02
CPU	(256K)	965-0027-00	A3-2	C5	960-5007-00	Voice 1	(4M)	965-0172-00		U17	960-5015-00
Voice 1	(512K)	965-0029-00		6F	960-7001-02	Voice 2	(4M)	965-0173-00		U21	960-5010-00
Voice 2	(512K)	965-0030-00		4F	960-7001-02	Voice 3	(4M)	965-0174-00		U36	960-5015-00
Sound	(256K)	965-0028-00		7F	960-5007-00	Sound	(512K)	965-0171-00		U7	960-7001-02
						Display	(4M)	965-0170-00	A1.02	ROM 0	960-5015-00
<b>Back to the Future</b>						<b>Guns N' Roses</b>					
CPU	(256K)	965-0041-00	A2-0	B5	960-5007-00	CPU	(512K)	965-0175-00	A3.00	C5	960-7001-02
CPU	(256K)	965-0042-00	A2-0	C5	960-5007-00	Voice 1	(4M)	965-0178-00		U17	960-5015-00
Voice 1	(512K)	965-0044-00		6F	960-7001-02	Voice 2	(4M)	965-0179-00		U21	960-5010-00
Voice 2	(512K)	965-0045-00		4F	960-7001-02	Voice 3	(4M)	965-0180-00		U36	960-5015-00
Sound	(256K)	965-0043-00		7F	960-5007-00	Voice 4	(4M)	965-0181-00		U37	960-5015-00
						Sound	(512K)	965-0177-00		U7	960-7001-02
						Display	(4M)	965-0176-00	A3.00	ROM 0	960-5015-00
<b>The Simpsons</b>						<b>Maverick *</b>					
CPU	(128K)	965-0051-00	A2-7	B5	960-5006-00	CPU	(512K)	965-0182-00	A4.04	C5	960-7001-02
CPU	(256K)	965-0052-00	A2-7	C5	960-5007-00	Voice 1	(4M)	965-0186-00		U17	960-5015-00
Voice 1	(512K)	965-0054-00		6F	960-7001-02	Voice 2	(4M)	965-0187-00		U21	960-5010-00
Voice 2	(512K)	965-0055-00		4F	960-7001-02	Voice 3	(4M)	965-0187-01		U36	960-5015-00
Sound	(256K)	965-0053-00		7F	960-5007-00	Sound	(512K)	965-0185-00		U7	960-7001-02
						Display*	(4M)	965-0183-00	A4.01	ROM 0	960-5015-00
						Display*	(4M)	965-0184-00	A4.01	ROM 3	960-5015-00
<b>Checkpoint</b>						<b>Mary Shelley's Frankenstein *</b>					
CPU	(128K)	965-0056-00	A1-7	B5	960-5006-00	CPU	(512K)	965-0188-00	A1.03	C5	960-7001-02
CPU	(256K)	965-0134-00	A1-7	C5	960-5007-00	Voice 1	(4M)	965-0192-00		U17	960-5015-00
Voice 1	(1M)	965-0057-00		F7	960-5009-00	Voice 2	(4M)	965-0193-00		U21	960-5010-00
Voice 2	(1M)	965-0058-00		F5	960-5009-00	Voice 3	(4M)	965-0194-00		U36	960-5015-00
Sound	(256K)	965-0059-00		F4	960-5007-00	Sound	(512K)	965-0191-00		U7	960-7001-02
Display	(512K)	965-0060-00	CP80	U8	960-7001-02	Display*	(4M)	965-0189-00	A1.03	ROM 0	960-5015-00
						Display*	(4M)	965-0190-00	A1.03	ROM 3	960-5015-00
<b>Teenage Mutant Ninja Turtles</b>						<b>Baywatch *</b>					
CPU	(128K)	965-0061-00	A1.04	B5	960-5006-00	CPU	(512K)	965-0195-00	A4.00	C5	960-7001-02
CPU	(256K)	965-0062-00	A1.04	C5	960-5007-00	Voice 1	(4M)	965-0196-00		U17	960-5015-00
Voice 1	(1M)	965-0063-00		F5/6	960-5009-00	Voice 2	(4M)	965-0197-00		U21	960-5010-00
Voice 2	(1M)	965-0064-00		F4/5	960-5009-00	Sound	(512K)	965-0199-00		U7	960-7001-02
Sound	(256K)	965-0065-00		F7	960-5007-00	Display*	(4M)	965-0200-00	A4.00	ROM 0	960-5015-00
Display	(512K)	965-0066-00	A1.04	U8	960-7001-02	Display*	(4M)	965-0201-00	A4.00	ROM 3	960-5015-00
<b>Batman</b>						<b>Batman Forever *</b>					
CPU	(128K)	965-0067-00	A1.06	B5	960-5006-00	CPU	(512K)	965-0202-00	A3.02	C5	960-7001-02
CPU	(256K)	965-0135-00	A1.06	C5	960-5007-00	Voice 1	(4M)	965-0203-00		U17	960-5015-00
Voice 1	(2M)	965-0068-00		U17	960-5010-00	Voice 2	(4M)	965-0204-00		U21	960-5010-00
Voice 2	(1M)	965-0069-00		U21	960-5010-00	Sound	(512K)	965-0205-00		U7	960-7001-02
Sound	(256K)	965-0070-00		U7	960-5007-00	Display*	(4M)	965-0206-00	A3.00	ROM 0	960-5015-00
Display	(1M)	965-0071-00	A1.06	U8	960-5009-00	Display*	(4M)	965-0207-00	A3		

## APPENDIX B

### Semi-Conductors / Integrated Circuits (I.C.) / Relays Cross-Reference Table

Table No	Type	Source Number	STERN® PINBALL	NTE®	ECG®	Radio Shack®	RCA®
<b>RECTIFICATION, BLOCKING, DAMPENING DIODES AND/OR LIGHT EMITTING DIODES (LEDs)</b>							
<b>1</b>	Diode	1N4001	112-5001-00	NTE552	ECG552	- - - - -	SK9000
	Diode	1N4004	112-5003-00	NTE116	ECG116	276-1103	SK3312
	Diode	1N5401	112-0056-00	NTE5801	ECG5801	276-1143	SK9004
	Diode	1N5404	112-5004-00	NTE5804	ECG5804	276-1144	SK9007
	Diode	T6A10L	112-5006-01	NTE5812	ECG5812	- - - - -	- - - - -
	Diode	FR302	112-5009-00	NTE588	ECG588	- - - - -	SK5014
	Diode, Signal	1N914	112-5014-00	- - - - -	- - - - -	- - - - -	- - - - -
LED	<b>MT5000UR</b> or <b>TLRH180P</b> (T1-3/4 GaAlAs)	165-5052-00 <i>(old SPI Part No: 165-5100-00)</i>	- - - - -	- - - - -	276-066B	- - - - -	
<b>ZENER DIODES</b>							
<b>2</b>	Diode	1N4742A 12v	112-0061-00	NTE142A	ECG142A	276-563	SK12V
	Diode	1N4760B 68v	112-0062-00B	NTE5092A	ECG5092A	- - - - -	SK68V
	Diode	1N4764A 100v	112-0049-00A	NTE5096A	ECG5096A	- - - - -	SK100V
	Diode	1N5228 3.9v	112-0053-00	NTE5007A	ECG5007A	- - - - -	SK3A9
	Diode	1N5234B 6.2v	112-0047-00B	NTE5013A	ECG5013A	276-561	SK6A2
	Diode	1N5379 110v	112-0072-00	NTE5157	ECG5157	- - - - -	SK110X
	Diode	1N6267A 6.8v	112-5011-00	NTE4902	ECG4902	- - - - -	- - - - -
	Diode	1N4752A 33v	112-5010-00A	NTE147A	ECG147A	- - - - -	SK33V
Diode	1N4736 6.8v 1w	112-5007-00	NTE5071A	ECG5071A	- - - - -	- - - - -	
<b>TRANSISTORS - TYPE FET, NPN, PNP AND/OR SCR</b>							
<b>3</b>	FET Trans.	STP20N10L	110-0106-00	NTE2987	ECG2987	- - - - -	- - - - -
	FET Trans.	STP19N06L	110-0088-00	NTE2985	ECG2985	- - - - -	- - - - -
	FET Trans.	VN02N	110-0089-00	- - - - -	- - - - -	- - - - -	- - - - -
	NPN Trans.	2N4401	110-0073-00	NTE85	ECG85	276-2009	SK3124A
	NPN Trans.	2N6427	110-0070-00	NTE48	ECG48	- - - - -	SK4906
	NPN Trans.	MJE340	110-0071-00	NTE157	ECG157	- - - - -	SK3747
	NPN Trans.	MPSA42	110-0082-00	NTE287	ECG287	- - - - -	SK3232
	NPN Trans.	2N3904	110-0069-00	NTE123AP	ECG123AP	276-2009	- - - - -
	NPN Trans.	TIP122	110-0067-00	NTE261	ECG261	276-2068	SK3896
	NPN Trans.	MJE15030	110-0101-00	NTE375	ECG375	- - - - -	SK9118
	PNP Trans.	2N5401	110-0078-00	NTE288	ECG288	- - - - -	SK3434
	PNP Trans.	MJE15031	110-0103-00	NTE292	ECG292	- - - - -	SK3441
	PNP Trans.	MJE350	110-0072-00	NTE374	ECG374	- - - - -	SK9042
	PNP Trans.	MPSA92	110-0100-00	NTE288	ECG278	- - - - -	SK3434
	PNP Trans.	TIP42	110-0068-00	NTE332	ECG332	- - - - -	SK9236
	PNP Trans.	TIP32C	110-0081-00	NTE292	ECG292	- - - - -	SK3441
	PNP Trans.	TIP36C	110-0077-00	NTE393	ECG393	- - - - -	SK3961
	SCR Trans.	2N5060	110-0074-00	NTE5400	ECG5400	276-1067	SK3950
SCR Trans.	SCR2800B	110-0083-00	NTE5461-8	ECG5461-8	- - - - -	- - - - -	
<b>BRIDGE RECTIFIERS (BR)</b>				<b>Comments:</b>			
<b>4</b>	BR (Present)	DB3501 or CM3501	112-5000-00	For White Star I/O Bds., BR = 35 Amp @ 100v P.I.V.			
	<b>RELAYS</b>				<b>Comments:</b>		
<b>5</b>	Relay	FRL-264 D024/02CK	190-5002-00	For PPB, Power Supply, & White Star I/O Boards, Relay = 24v DC 10 Amp DPDT			
	Relay	FRL-264 D006/04CV	190-5001-00	For CPU Boards, Relay = 6v DC 5 Amp 4 Pole DT			





# APPENDIX C

## Production Start Date, Manual Part No., ROM Size & Positions and Jumper W6 Installed Note‡ (White Star Board System & S.A.M. System Only\*)



Game Name White Star Bd. System™	Production Start Date and Manual Part Nr.	CPU/Sound Board Sound U7 512K CPU/Sound Board Game U210 1MB CPU/Sound Board Voice ROMS:				Jumper Installed (‡ see Note)	
		U17	U21	U36	U37		
* Note: For complete Appendix Information for Games <b>Laser War</b> through <b>Batman Forever</b> , see any Service Game Manual between <b>Apollo 13</b> through <b>Ripley's Believe It or Not!</b> or on-line at our website <a href="http://www.sternpinball.com/parts.htm">www.sternpinball.com/parts.htm</a> ; also available on CD-R, 970-2003-00 ( <b>The Simpsons™ Pinball Party</b> , <b>T3®</b> and <b>The Lord of the Rings™</b> ).							
29	Apollo 13 (A13)	NOV 95 780-5044-00	4MB	4MB	4MB	Not Used	n / a
30	Golden Eye	FEB 96 780-5042-00	4MB	4MB	Not Used	Not Used	n / a
31	Twister	APR 96 780-5041-00	4MB	4MB	Not Used	Not Used	n / a
32	ID4: Independence Day	JUL 96 780-5045-00	4MB	4MB	Not Used	Not Used	n / a
33	Space Jam	OCT 96 780-5043-00	4MB	4MB	4MB	Not Used	n / a
34	The Star Wars Trilogy - Sp. Ed.	FEB 97 780-5056-00	4MB	4MB	Not Used	Not Used	n / a
35	The Lost World: Jurassic Park	JUN 97 780-5053-00	4MB	4MB	Not Used	Not Used	n / a
36	The X-Files	AUG 97 780-5046-00	4MB	4MB	Not Used	Not Used	n / a
37	Starship Troopers	NOV 97 780-5059-00	4MB	4MB	4MB	Not Used	n / a
38	Viper Night Drivin'	FEB 98 780-5035-00	4MB	4MB	4MB	4MB	n / a
39	Lost In Space	JUN 98 780-5060-00	4MB	4MB	4MB	4MB	n / a
40	Godzilla	SEP 98 780-5040-00	4MB	4MB	4MB	4MB	n / a
41	South Park	JAN 99 780-5071-00	8MB	8MB	8MB	8MB	W6
42a	Harley-Davidson®	AUG 99 780-5067-01	8MB	8MB	8MB	8MB	W6
42b	Harley-Davidson® 2nd Ed.	SEP 02 780-5067-10	8MB	8MB	8MB	8MB	W6
42c	Harley-Davidson® 3rd Ed.	OCT 04 780-5087-00	8MB	8MB	8MB	8MB	W6
43a	Striker Xtreme	MAR 00 780-5068-01	8MB	8MB	8MB	8MB	W6
43b	NFL	OCT 00 780-5073-00	8MB	8MB	8MB	8MB	W6
44	Sharkey's Shootout	JUL/OCT 00 780-5072-01	8MB	8MB	8MB	Not Used	W6
45	High Roller Casino	JAN 01 780-5065-00	8MB	8MB	8MB	8MB	W6
46	Austin Powers™	MAY 01 780-5074-00	8MB	8MB	8MB	8MB	W6
47	MONOPOLY®	SEP 01 780-5075-00	8MB	8MB	8MB	Not Used	W6
48	Playboy	FEB 02 780-5076-00	8MB	8MB	8MB	8MB	W6
49	RollerCoaster Tycoon™	AUG 02 780-5078-00	8MB	8MB	8MB	Not Used	W6
50	The Simpsons™ Pinball Party	JAN 03 780-5077-00	8MB	8MB	8MB	8MB	W6
51	T3®: Rise of the Machines™	MAY 03 780-5079-00	8MB	8MB	8MB	8MB	W6
52	The Lord of the Rings™	NOV 03 780-5080-00	8MB	8MB	8MB	8MB	
53	Ripley's Believe It or Not!®	APR 04 780-5081-00	8MB	8MB	8MB	8MB	

‡ Additional Information for **Installed Jumper** (above games 41-51):

• Installed **W6** so 8MB ROMS can be utilized. See the **CPU/Sound Board Schematic** (Sheet 2 of 3, Address Location 3E) in the games' Service Game Manual. Games 52 - 57 CPU/Sound Board differ than <51 (See Appendix D).

See **Apdx. A** for more detailed information on **Pinball Game Firmware** (ROM Name, Size, Part Numbers, USA Version & Checksum and Board Locations).

Game Name White Star Board System™	Production Start Date and Manual Part Nr.	CPU/Sound Board Sound U7 512K CPU/Sound Board Game U210 1MB CPU/Sound Board Voice ROMS:				
		U17	U21	U36	U37	
54	Elvis®	AUG 04 780-5084-00	8MB	8MB	8MB	8MB
55	The Sopranos™	FEB 05 780-5085-00	8MB	8MB	8MB	8MB
56	NASCAR®	JUL 05 780-5086-00	8MB	8MB	8MB	8MB
57	Grand Prix	SEP 05 780-5091-00	8MB	8MB	8MB	8MB

See **Apdx. A** for more detailed information on **Pinball Game Firmware** (ROM Name, Size, Part Numbers, USA Version & Checksum and Board Locations).

Game Name S.A.M. System	Production Start Date and Manual Part Nr.	S.A.M. System CPU/Sound Board Boot EPROM U9			
		965-BOOT-SAM (Programmed)			
58	World Poker Tour™ (WPT)	JUN 06 780-5088-00	8MB	B-02 V2.1+ chksum \$F625	LOC: U9
59	The Simpsons™ Kooky Carnival	APR 06 780-5090-00	8MB	B-02 V2.1+ chksum \$F625	LOC: U9
60	©Disney's Pirates of the Caribbean	AUG 06 780-5092-00	8MB	B-02 V2.1+ chksum \$F625	LOC: U9
61	Famil Guy™	DEC 06 780-5093-00	8MB	B-02 V2.1+ chksum \$F625	LOC: U9
62	Spider-Man™	MAY 07 780-5094-00	8MB	B-02 V2.1+ chksum \$F625	LOC: U9

**Games 58 – current, S.A.M. System** : CPU/Sound & I/O Power Driver PCBs differ than White Star (previous Games 29 – 57); Disp. Controller Not Required.





# APPENDIX D

## Board Type (White Star Board System\* Only) Table



Game Name	Flipper	I/O Power Driver	CPU/Sound Stereo	Disp. Power Supply	Dot Matrix Display	Display Controller	OPTO Transmitter	OPTO Receiver	OPTO Application
Apollo 13	520-5080-00 2-Flipper	520-5137-00	520-5136-00	520-5138-00	520-5052-00 128 X 32 Dots	520-5055-01	520-5124-00 Single OPTO	520-5125-00 Single OPTO	5-Ball Trough over Up-Kicker
	Miscellaneous PC Boards:	Light Boards 520-5130-01, -04 & -05 Magnet Interface, 7-Segment Display & Light Bd. 520-5130-06 Magnet Driver Board 520-5130-02 Switch Membrane Board 520-5130-03				Relay Board 520-5010-00			
Golden Eye	520-5080-00 2-Flipper	520-5137-00	520-5136-00	520-5138-00	520-5052-00 128 X 32 Dots	520-5055-01	520-5124-00 Single OPTO	520-5125-00 Single OPTO	5-Ball Trough over Up-Kicker
	Miscellaneous PC Boards:	Light Boards 520-5128-05 through -08		Mag. Processor X2 Driver Bd. 520-5143-00	Relay Board 520-5010-00				

GAMES HEREON NO LONGER REQUIRE THE FLIPPER BOARD WITH THE WHITE STAR BOARD SYSTEM™

Game Name	I/O Power Driver	CPU/Sound Mono	Disp. Power Supply	Dot Matrix Display	Display Controller	OPTO Transmitter	OPTO Receiver	OPTO Application	Misc OPTO & App.
Twister	520-5137-01	520-5136-10	520-5138-00	520-5052-00 128 X 32 Dots	520-5055-01	520-5124-00 Single OPTO	520-5125-00 Single OPTO	5-Ball Trough over Up-Kicker	
	Miscellaneous PC Boards:	Light Boards 520-5145-01 through -07		Mag. Drv. Bd. 520-5143-00	Relay Board 520-5010-00				
Independence Day (ID4)	520-5137-01	520-5136-10	520-5138-00	520-5052-00 128 X 32 Dots	520-5055-01	520-5124-00 Single OPTO	520-5125-00 Single OPTO	4-Ball Trough over Up-Kicker	
	Miscellaneous PC Boards:	Light Boards 520-5149-01 through -10		Servo Mtr. Bd. 520-5152-00		520-5082-00 Long Hop OPTO	520-5083-00 Long Hop OPTO	Alien Head Enter	
Space Jam	520-5137-01	520-5136-10	520-5138-00	520-5052-00 128 X 32 Dots	520-5055-01	520-5124-00 Single OPTO	520-5125-00 Single OPTO	5-Ball Trough over Up-Kicker	
	Miscellaneous PC Boards:	2X 7-Segment Display Board 520-5153-00							
The Star Wars Trilogy - Special Ed.	520-5137-01	520-5136-10	520-5138-00	520-5052-00 128 X 32 Dots	520-5055-01	520-5124-00 Single OPTO	520-5125-00 Single OPTO	4-Ball Trough over Up-Kicker	
	Miscellaneous PC Boards:	Relay Board 520-5010-00							
The Lost World: J.P.	520-5137-01	520-5136-10	520-5138-00	520-5052-00 128 X 32 Dots	520-5055-01	520-5124-00 Single OPTO	520-5125-00 Single OPTO	4-Ball Trough over Up-Kicker	520-5162-00 2-Pos. Motor Sensor on Snagger Motor
	Miscellaneous PC Boards:	DC Relay Bd. 520-5066-00	Shaker Mtr. Bd. 520-5065-00						
The X-Files	520-5137-01	520-5136-10	520-5138-00	520-5052-00 128 X 32 Dots	520-5055-01	520-5124-00 Single OPTO	520-5125-00 Single OPTO	4-Ball Trough over Up-Kicker	520-5155-00 3-Pos. Motor Sensor on File Cab. Motor
	Miscellaneous PC Boards:					520-5082-00 Long Hop OPTO	520-5083-00 Long Hop OPTO	File Cabinet Enter	
Starship Troopers	520-5137-01	520-5136-15	520-5138-00	520-5052-00 128 X 32 Dots	520-5055-02	520-5124-00 Single OPTO	520-5125-00 Single OPTO	4-Ball Trough over Up-Kicker	
	Miscellaneous PC Boards:	4X 7-Segment Display Board 520-5166-00					520-5082-00 Long Hop OPTO	520-5083-01 Long Hop OPTO	L/R Orbit Lane Enter
Viper Night Drivin'	520-5137-01	520-5136-16	520-5138-00	520-5052-00 128 X 32 Dots	520-5055-03	520-5124-00 Single OPTO	520-5125-00 Single OPTO	4-Ball Trough over Up-Kicker	
	Miscellaneous PC Boards:	Relay Board 520-5010-00					520-5082-00 Long Hop OPTO	520-5083-01 Long Hop OPTO	Jump Ramp
Lost In Space	520-5137-01	520-5136-16	520-5138-00	520-5052-00 128 X 32 Dots	520-5055-03	515-0173-00 Dual OPTO	515-0174-00 Dual OPTO	4-Ball Trough over Up-Kicker	
	Miscellaneous PC Boards:	Relay Board 520-5010-00							
Godzilla	520-5137-01	520-5136-16	520-5138-00	520-5052-00 128 X 32 Dots	520-5055-03	515-0173-00 Dual OPTO	515-0174-00 Dual OPTO	4-Ball Trough over Up-Kicker	
	Miscellaneous PC Boards:	Shaker Mtr. Bd. 520-5065-00							
South Park	520-5137-01	520-5136-16	520-5138-00	520-5052-00 128 X 32 Dots	520-5055-03	515-0173-00 Dual OPTO	515-0174-00 Dual OPTO	5-Ball Trough over Up-Kicker	
	Miscellaneous PC Boards:					520-5082-00 Long Hop OPTO	520-5083-01 Long Hop OPTO	Kenny Under Trough Enter	
Harley-Davidson® 1st-3rd* Editions	520-5137-01	520-5136-16 *520-5300-00*	520-5138-00	520-5052-00 128 X 32 Dots	520-5055-03	515-0173-00 Dual OPTO	515-0174-00 Dual OPTO	4-Ball Trough over Up-Kicker	
	Miscellaneous PC Boards:	Relay Board 520-5010-00	Shaker Mtr. Bd. 520-5065-00	Diode Board 520-5146-00		520-5082-00 Long Hop OPTO	520-5083-01 Long Hop OPTO	Motorcycle Enter	
Striker Xtreme (NFL)	520-5137-01	520-5136-16	520-5138-00	520-5052-00 128 X 32 Dots	520-5055-03	515-0173-00 Dual OPTO	515-0174-00 Dual OPTO	4-Ball Trough over Up-Kicker	520-5155-00 3-Pos. Motor Sensor on Goalie Motor
	Miscellaneous PC Boards:	DC Relay Bd. 520-5066-00	Relay Board 520-5010-00	Diode Board 520-5146-00	for UK ONLY- Solenoid Expander Bd. 520-5192-00	520-5082-00 Long Hop OPTO	520-5083-01 Long Hop OPTO	Goalie Under- Trough Enter	
Sharkey's Shootout	520-5137-64	520-5136-64	520-5138-00	520-5052-00 128 X 32 Dots	520-5055-03	515-0173-00 Dual OPTO	515-0174-00 Dual OPTO	4-Ball Trough over Up-Kicker	520-5194-00 4-Pos. Motor Sensor on ? -Ball Motor
	Miscellaneous PC Boards:	Relay Board 520-5010-00	Sol. Exp. Bd. 520-5192-00						
High Roller Casino	520-5137-01	520-5136-16	520-5138-00	520-5052-00 128 X 32 Dots	520-5055-03	515-0173-00 Dual OPTO	515-0174-00 Dual OPTO	4-Ball Trough over Up-Kicker	520-5194-00 4-Pos. Motor Sensor on Roulette Wheel Motor
	Miscellaneous PC Boards:	Dot Display (5X7) in Slot Mach. 520-5197-00			for UK ONLY- Solenoid Expander Bd. 520-5192-00		520-5082-00 Long Hop OPTO	520-5083-01 Long Hop OPTO	Ball Lock under Roulette
Austin Powers™	520-5137-01	520-5136-16	520-5138-00	520-5052-00 128 X 32 Dots	520-5055-03	515-0173-00 Dual OPTO	515-0174-00 Dual OPTO	4-Ball Trough over Up-Kicker	520-5212-00 Pulse-Stretcher OPTO on Spini-Me
	Miscellaneous PC Boards:	Relay Bd. (X3) 520-5010-00			for UK ONLY- Solenoid Expander Bd. 520-5192-00	520-5082-00 Long Hop OPTO	520-5083-01 Long Hop OPTO	Time Machine Ramp	
MONOPOLY®	520-5137-01	520-5136-16	520-5138-00	520-5052-00 128 X 32 Dots	520-5055-03	515-0173-00 Dual OPTO	515-0174-00 Dual OPTO	4-Ball Trough over Up-Kicker	
	Miscellaneous PC Boards:	DC Relay Bd. 520-5066-00	Mini-Dot Display (3 by 5X7) 520-5197-00 (Electric C- Sign)		for UK ONLY- Solenoid Expander Bd. 520-5192-00	520-5218-00 4-Pos. OPTO	520-5210-00 4-Pos. OPTO	Bank Door	

Table continued on the next page.





# APPENDIX D

## Board Type (White Star Board System\* & S.A.M. System\*\* Only) Table



Game Name	I/O Power Driver	CPU/Sound (old & new)	Disp. Power Supply	Dot Matrix Display	Display Controller	OPTO Transmitter	OPTO Receiver	OPTO Application	Misc OPTO & App.
Playboy	520-5137-01	520-5136-16	520-5138-00	520-5052-00 128 X 32 Dots	520-5055-03	515-0173-00 Dual OPTO	515-0174-00 Dual OPTO	4-Ball Trough over Up-Kicker	
	Miscellaneous PC Boards:	DC Relay Bd. 520-5066-00	Relay Bd. 520-5010-00		for UK ONLY- Solenoid Expander Bd. 520-5192-00				
RollerCoaster Tycoon™	520-5137-01	520-5136-16	520-5138-00	520-5052-00 128 X 32 Dots	520-5055-03	515-0173-00 Dual OPTO	515-0174-00 Dual OPTO	4-Ball Trough over Up-Kicker	520-5222-00 1-Position Switch Detect on Wheel Spin
	Miscellaneous PC Boards:	DC Relay Bd. 520-5066-00	Mini-Dot Display (3 by 5X7) 520-5221-00 (Ramp Enter Sign)		for UK ONLY- Solenoid Expander Bd. 520-5192-00	520-5082-00 Long Hop OPTO	520-5083-01 Long Hop OPTO	Behind 1-Bank Drop Target	
The Simpsons™ Pinball Party	520-5137-01	520-5136-16	520-5138-00	520-5052-00 128 X 32 Dots	520-5055-03	515-0173-00 Dual OPTO	515-0174-00 Dual OPTO	4-Ball Trough over Up-Kicker	
	Miscellaneous PC Boards:	LED Bd. 520-5219-00	Color Dot Display (4 by 5X7) 520-5225-00 (TV Set)		for UK ONLY ◀◀◀ Aux. Driver Bd. 520-5068-01				
Terminator® 3: Rise of the Machines™	520-5137-01	<b>520-5136-16</b>	520-5138-00	520-5052-00 128 X 32 Dots	520-5055-03	515-0173-00 Dual OPTO	515-0174-00 Dual OPTO	4-Ball Trough over Up-Kicker	
	Miscellaneous PC Boards:				for UK ONLY ◀◀◀ Aux. Driver Bd. 520-5068-01	515-7307-00 Single OPTO	515-7308-00 Single OPTO	TXCannon Trough	
The Lord of the Rings™	520-5137-01	<b>New</b> 520-5300-00	520-5138-00	520-5052-00 128 X 32 Dots	520-5055-03	515-0173-00 Dual OPTO	515-0174-00 Dual OPTO	4-Ball Trough over Up-Kicker	500-6746-00 (White Trans.) 500-6747-00 (Black Rec.)
	Miscellaneous PC Boards:	19-LED PCB 520-5242-00	OPTO Transmitter / Receiver Amplifier PCB 520-5239-00		for UK ONLY ◀◀◀ Aux. Driver Bd. 520-5068-01	515-7307-00 Single OPTO	515-7308-00 Single OPTO	Orthanc Tower Trough	
Ripley's Believe It or Not!®	520-5137-01	520-5300-00	520-5138-00	520-5052-00 128 X 32 Dots	520-5055-03	515-0173-00 Dual OPTO	515-0174-00 Dual OPTO	4-Ball Trough over Up-Kicker	500-6775-00 OPTO Trnscvr
	Miscellaneous PC Boards:	520-5236-00 X3 Dot Display	OPTO Transmitter / Receiver Amplifier PCB 520-5239-01		for UK ONLY ◀◀◀ Aux. Driver Bd. 520-5068-01	520-5234-00 3-Pos. OPTO	520-5234-00 3-Pos. OPTO	Vari-Target	520-5235-03 X3 Aux. Drvr
Elvis®	520-5137-01	520-5300-00	520-5138-00	520-5052-00 128 X 32 Dots	520-5055-03	515-0173-00 Dual OPTO	515-0174-00 Dual OPTO	4-Ball Trough over Up-Kicker	
	Miscellaneous PC Boards:				for UK ONLY ◀◀◀ Aux. Driver Bd. 520-5068-01				
The Sopranos™	520-5137-01	520-5300-00	520-5138-00	520-5052-00 128 X 32 Dots	520-5055-03	515-0173-00 Dual OPTO	515-0174-00 Dual OPTO	4-Ball Trough over Up-Kicker	
	Miscellaneous PC Boards:				for UK ONLY ◀◀◀ Aux. Driver Bd. 520-5068-01				
NASCAR® and [INDSE]	520-5137-01	520-5300-00	520-5138-00	520-5052-00 128 X 32 Dots	520-5055-03	515-0173-00 Dual OPTO	515-0174-00 Dual OPTO	4-Ball Trough over Up-Kicker	500-6775-00 OPTO Trans. (Qty. 16) Switch Detect.
	Miscellaneous PC Boards:	520-5235-03 X3 Aux. Drvr	OPTO Transmitter / Receiver Amplifier PCB 520-5239-01		for UK ONLY ◀◀◀ Aux. Driver Bd. 520-5068-01				
Grand Prix	520-5137-01	520-5300-00	520-5138-00	520-5052-00 128 X 32 Dots	520-5055-03	515-0173-00 Dual OPTO	515-0174-00 Dual OPTO	4-Ball Trough over Up-Kicker	500-6775-00 OPTO Trans. (Qty. 16) Switch Detect.
	Miscellaneous PC Boards:	520-5235-03 X3 Aux. Drvr	OPTO Transmitter / Receiver Amplifier PCB 520-5239-01		for UK ONLY ◀◀◀ Aux. Driver Bd. 520-5068-01				

Game Name	I/O Power Driver**	CPU / Sound**	Disp. Power Supply	Dot Matrix Display	Dual OPTO Transmitter	Dual OPTO Receiver	Dual OPTO Transceiver	OPTO Transceiver Miscellaneous
World Poker Tour™ (WPT)	520-5249-00 Backbox	520-5246-00 Backbox	520-5138-00 Backbox	520-5052-00 128 X 32 Dots	515-0173-00 4-Ball Trough	515-0174-00 4-Ball Trough	500-6775-00 4 Switch Pairs (Qty. 8)	520-5251-00 'U' 1/per PCB Jail Bars Up Ace/Hole Mech 520-5252-04 'U' 4/per PCB Drop Targets 4- & 8- Banks
	Miscellaneous PCBs:	520-5254-00 50V Step-Up Drv	520-5250-14 14LED 5X7 Disp.	520-5239-01 OPTO Amplifier	520-5247-00 Ace/Hole Mech	520-5248-00 Ace/Hole Mech		
The Simpsons™ Kooky Carnival	520-5249-00 Back Door	520-5246-00 Back Door	520-5138-00 Cabinet Rear	520-5052-00 128 X 32 Dots			520-5253-00-ASY Coin Drop (Qty. 11)	
	Miscellaneous PCBs:	515-5742-00 Shaker PCB	500-6700-00 Relay (incl. Wiring + Conn.)					
©Disney's Pirates of the Caribbean	520-5249-00 Backbox	520-5246-00 Backbox	520-5138-00 Backbox	520-5052-00 128 X 32 Dots	515-0173-00 4-Ball Trough	515-0174-00 4-Ball Trough	500-6775-00 5 Switch Pairs (Qty. 10)	
	Miscellaneous PCBs:	520-5239-01 OPTO Amp. (X3)	511-5024-03 Relay (incl. Wiring + Conn.)	520-5238-00 : H-E-A-R-T LED PCB				
Family Guy™	520-5249-00 Backbox	520-5246-00 Backbox	520-5138-00 Backbox	520-5052-00 128 X 32 Dots	515-0173-00 4-Ball Trough	515-0174-00 4-Ball Trough	500-6775-00 3 Switch Pairs (Qty. 6)	520-5252-01 'U' 1/per PCB Drop Target 1-Bank
	Miscellaneous PCBs:	520-5239-01 OPTO Amp. (X2)	520-5261-00 Stepper Motor	511-5042-01 Trgt. Sensor (X2)			500-6775-01 1 Switch Pair (Qty. 2)	520-5252-04 'U' 4/per PCB Drop Target 4-Bank
Spider-Man™	520-5249-00 Backbox	520-5246-00 Backbox	520-5138-00 Backbox	520-5052-00 128 X 32 Dots	515-0173-00 4-Ball Trough	515-0174-00 4-Ball Trough	500-6775-00 3 Switch Pairs (Qty. 6)	
	Miscellaneous PCBs:	520-5239-01 OPTO Amp. (X2)						



# APPENDIX D

## Board Type Table

Game Name	Flipper	Sound	Power Supply	Display X-Digit
<ul style="list-style-type: none"> <li>Laser War</li> </ul>	2-Flipper Board Not Required	<i>initial:</i> 520-5002-00 <i>replaced with:</i> 520-5002-02 <i>520-5002-01 was not used.</i>	520-5000-00	Master: 520-5004-00 plus: 520-5005-00 (Qty. 2); 7 Digit Alpha/Numeric 520-5006-00 (Qty. 2); 7 Digit Numeric 520-5007-00 (Qty. 1); 4 Digit Numeric
<ul style="list-style-type: none"> <li>Secret Service</li> <li>Torpedo Alley</li> </ul>	3-Flipper Board Not Required	520-5002-02		520-5014-01 7 Digit Alpha/Numeric Combined
<ul style="list-style-type: none"> <li>Time Machine</li> </ul>	2-Flipper Board Not Required			520-5030-00 16 Digit Alpha/Numeric Combined
<ul style="list-style-type: none"> <li>Playboy 35th Anniversary *</li> <li>ABC Monday Night Football *</li> <li>Robocop</li> <li>Phantom of the Opera</li> <li>Back to the Future</li> <li>The Simpsons</li> </ul>	520-5033-00 2-Flipper <i>(*only for 100 games of Playboy 35th Anniv. &amp; ABC Mon. Night Football)</i>			
		520-5002-03		

Game Name	Flipper	Sound	Power Supply	Dot Matrix Display	Display Controller	OPTO Transmitter	OPTO Receiver	OPTO Application
<ul style="list-style-type: none"> <li>Checkpoint</li> <li>Teenage Mutant Ninja Turtles</li> </ul>	520-5033-00 2-Flipper	520-5002-03	520-5047-00	520-5042-00 128 X 16	520-5055-00			
<ul style="list-style-type: none"> <li>Batman</li> <li>Star Trek 25th Anniv.</li> <li>Hook</li> </ul>		520-5050-01						
<ul style="list-style-type: none"> <li>Lethal Weapon 3</li> </ul>		520-5050-02	520-5047-01					
<ul style="list-style-type: none"> <li>Star Wars</li> <li>Rocky &amp; Bullwinkle &amp; Friends</li> </ul>			520-5052-00 128 X 32					
<ul style="list-style-type: none"> <li>Jurassic Park</li> </ul>		520-5076-00 3-Flipper		520-5047-02				
<ul style="list-style-type: none"> <li>Last Action Hero</li> </ul>		520-5070-00 2-Flipper	520-5055-01					
<ul style="list-style-type: none"> <li>Tales from the Crypt</li> </ul>		520-5076-00 3-Flipper						
<ul style="list-style-type: none"> <li>WWF Royal Rumble</li> </ul>		520-5070 / 5080 -00 4-Flipper (2X2)	520-5077-00					
<ul style="list-style-type: none"> <li>Guns N' Roses</li> </ul>		520-5076-00 3-Flipper	520-5050-03					
<ul style="list-style-type: none"> <li>Maverick</li> </ul>		520-5076-00 3-Flipper	520-5077-00					
<ul style="list-style-type: none"> <li>Mary Shelley's Frankenstein</li> </ul>	520-5076-00 3-Flipper	520-5047-03	520-5075-00 192 X 64	520-5092-01	520-5102-00 Single OPTO	520-5103-00 Single OPTO	Paddle Boat Wheel Enter	
<ul style="list-style-type: none"> <li>Baywatch</li> </ul>	520-5070 / 5080 -00 4-Flipper (2X2)	520-5126-02			520-5124-00 Single OPTO	520-5125-00 Single OPTO	5-Ball Trough over Up-Kicker	
<ul style="list-style-type: none"> <li>Batman Forever</li> </ul>	520-5076-00 3-Flipper				520-5124-00 Single OPTO	520-5125-00 Single OPTO	4-Ball Trough over Up-Kicker	

Miscellaneous Boards (Lamp Boards & Relay Boards) not listed above can be found in each individual game manual.





# APPENDIX E

## Flipper Coil (White Star Board System\* & S.A.M. System\*\* Only) Table



Typical Coil Diode 1N4004 unless noted otherwise (Diode Top = above lugs next to windings; Diode Below (Bottom) = under lugs opposite of windings).

STANDARD COILS (TYPICAL APPLICATIONS)			LARGE COILS (FLIPPERS & SPECIAL APPLICATIONS)		
Ga.-Turn	Res (Ω)	SPI Part Number and Comments	Ga.-Turn	Res (Ω)	SPI Part Number and Comments
20-400	1.0 Ω	090-5021-use : -00 Diode Top	21-900	call Ω	090-5020-use : -01 3-Lugs + 1N4004 & 1N5404 Diodes -10 Diode Top <BROWN><RED>
22-500	1.7 Ω	090-5017-use : -00 Diode Top	22-750 / 30-2600	2.6 Ω 92.0 Ω	090-5011-use : -00 DUAL WND COIL // 3-Lugs Diode x2
22-600	2.2 Ω	090-5017-use : -0B Diode Below // -0T Diode Top			
23-700	3.1 Ω	090-5022-use : -0B Diode Below // -0T Diode Top	22-900	3.45 Ω	090-5020-use : -20T Diode Top <YELLOW> // -20-ND No Diode
23-750	3.4 Ω	090-5019-use : -00 Diode Top			
23-800	3.6 Ω	090-5001-use : -0B Diode Below // -0T Diode Top // -NL No Lugs 11" Leads // -ND No Diode	22-1080	4.2 Ω	090-5032-use : -0B D. Below // -0T D. Top <YEL-GRN> -NL No Diode
23-840	4.0 Ω	090-5005-use : -00 Diode Top			
23.5-765	3.6 Ω	090-5037-use : -03 Diode Top	23-620 / 30-2600	2.4 Ω 75.0 Ω	090-5006-use : -00 DUAL WND COIL // 3-Lugs Diode x2
24-900	5.0 Ω	090-5002-use : -02 Diode Top // -10 No Lugs 14" Leads			
24-940	5.5 Ω	090-5036-use : -0B Diode Below // -0T Diode Top use 090-5051-01 No Lugs 11" Leads	23-700 / 30-2600	3.0 Ω 83.5 Ω	090-5013-use : -00 DUAL WOUND COIL // Diode Top
25-1240	9.3 Ω	090-5034-use : -00 Diode Below			
26-1200	10.3 Ω	090-5044-use : -0B Diode Below // -0T Diode Top // -NL No Lugs 11" Leads // -ND No Diode	23-800 / 30-2600	2.4 Ω 90.5 Ω	090-5012-use : -00 DUAL WOUND COIL // Diode Top
27-1300	14.2 Ω	090-5003-use : -0T Diode Top			
27-1400	14.7 Ω	090-5015-use : -00 Diode Below	23-1100	5.1 Ω	090-5030-use : -0T Diode Top <ORANGE> -ND No Diode
27-1400	14.7 Ω	511-5031-00 Special App.: No Diode / Lugs + Conn.			
27-1500	16.3 Ω	090-5004-use : -0B Diode Below // -0T Diode Top	23-1200	7.1 Ω	090-5008-use : -00 Diode Top <BLACK>
29-2000	33.6 Ω	090-5016-use : -00 Diode Top			
<b>LARGE, MEDIUM &amp; MINI COILS (MAGNET APPLICATIONS)</b>			23-1500	4.4 Ω	090-5062-use : -00 Diode Top <BLUE>
20.5-480	2.9 Ω	090-5064-use : -02 No Lugs or Core; 14" Leads // Large			
22-650	4.3 Ω	090-5042-use : -00 No Lugs or Core; 6" Leads // Large -01 No Lugs or Core; 12" Leads // Large	24-1570	9.5 Ω	090-5025-use : -00 Diode Top <BLUE>
24-780	8.0 Ω	090-5061-use : -00 No Lugs or Core; 6" Lds. // Medium			
29-1000	15.2 Ω	090-5059-use : -00 Lugs + Diode + Magnet Core // Mini	25-1400	call Ω	090-5067-use : -0T Diode Top <RED>
31-1500	52.0 Ω	090-5054-00 : Straight Lugs + Diode + Mag Core // Mini 090-5055-00 : 90° Lugs + Diode + Magnet Core // Mini			
<b>MINI COILS (RESET / TRIP APPLICATIONS)</b>			25-1600	call Ω	090-5068-use : -0T Diode Top <WHITE>
27-950	call Ω	090-5046-use : -01 Diode Top			
28-1050	11.5 Ω	090-5046-use : -00 Diode Top	27-880	call Ω	500-6976-01 No Lugs or Diode + 6" Leads & Conn.
27-880	call Ω	500-6976-01 No Lugs or Diode + 6" Leads & Conn.			
31-590	call Ω	090-5010-use : -00 Diode Top	32-1250	35.0 Ω	515-6916-01 : includes Flap & Screw <YELLOW>
32-1250	35.0 Ω	515-6916-01 : includes Flap & Screw <YELLOW>			
32-1800	50.2 Ω	090-5031-use : -0B Diode Below // -0T Diode Top (515-6110-00) use 515-# to include mounting & armature brackets	33-1590	59.0 Ω	515-6916-00 : includes brackets <WHITE>
33-1590	59.0 Ω	515-6916-00 : includes brackets <WHITE>			

Please Note: Ohm values may vary +/- .03 depending on meter calibration.  
 Ordering Note: Coils typically should not come with Coil Sleeves. IF A SLEEVE EXISTS, ensure it is the correct sleeve for the application usage. For the correct Coil Sleeve, refer to the Game Assembly Drawing the coil exists on and order separately.



## Flipper Coil (White Star Board System\* Only) Table

GAME NAME	Nº of Flippers	FLIPPERS		FLIPPERS no E.O.S. Switch	
		SPI Nº / GAUGE-TURNS / Color		SPI Nº / GAUGE-TURNS / Color	
		LOWER LEFT	LOWER RIGHT	UPPER LEFT	UPPER RIGHT
Apollo 13	2	090-5032-0T 22-1080 -YEL-GRN-	SAME	Not Used	Not Used
Golden Eye	2	090-5032-0T 22-1080 -YEL-GRN-	SAME	Not Used	Not Used
Twister	2	090-5020-20T 22-900 -YELLOW-	090-5032-0T 22-1080 -YEL-GRN-	Not Used	Not Used
ID4: Independence Day	3	090-5032-0T 22-1080 -YEL-GRN-	SAME	Not Used	090-5020-30 23-900 -GREEN-
Space Jam †	2	090-5032-0T 22-1080 -YEL-GRN-	090-5020-20T 22-900 -YELLOW-	Not Used	Not Used
The Star Wars Trilogy - Special Edition †	2	090-5032-0T 22-1080 -YEL-GRN-	SAME	Not Used	Not Used
The Lost World: Jurassic Park †	2	090-5032-0T 22-1080 -YEL-GRN-	SAME	Not Used	Not Used
The X-Files †	2	090-5032-0T 22-1080 -YEL-GRN-	SAME	Not Used	Not Used
Starship Troopers †	3	090-5030-0T 23-1100 -ORANGE-	SAME	Not Used	090-5032-0T 22-1080 -YEL-GRN-
Viper Night Drivin' †	2	090-5030-0T 23-1100 -ORANGE-	SAME	Not Used	Not Used
Lost In Space †	2	090-5030-0T 23-1100 -ORANGE-	090-5032-0T 22-1080 -YEL-GRN-	Not Used	Not Used
Godzilla †	2	090-5032-0T 22-1080 -YEL-GRN-	SAME	Not Used	Not Used
South Park †	2	090-5030-0T 23-1100 -ORANGE-	SAME	Not Used	Not Used

† Coil Part Numbers ending with a "T" signifies the Diode is on the top of the lug (on the coil-winding side); Coil Part Numbers ending with a "B" signifies the Diode is on the bottom of the lugs.

Table continued on the next page.







# APPENDIX E

## Flipper Coil (White Star Board System\* & S.A.M. System\*\* Only) Table



GAME NAME	N <sup>o</sup> of Flippers	FLIPPERS w/E.O.S. Switch		FLIPPERS no E.O.S. Switch	
		SPI N <sup>o</sup> / GAUGE-TURNS / Color		SPI N <sup>o</sup> / GAUGE-TURNS / Color	
		LOWER LEFT	LOWER RIGHT	UPPER LEFT	UPPER RIGHT
Harley-Davidson® † and 1st through 3rd Editions	2	090-5032-0T <b>22-1080 -YEL-GRN-</b>	090-5030-0T <b>23-1100 -ORANGE-</b>	Not Used	Not Used
Striker Xtreme (NFL) †	3	090-5032-0T <b>22-1080 -YEL-GRN-</b>	090-5030-0T <b>23-1100 -ORANGE-</b>	090-5030-0T <b>23-1100 -ORANGE-</b>	Not Used
Sharkey's Shootout †	3	090-5030-0T <b>23-1100 -ORANGE-</b>	SAME	090-5030-0T <b>23-1100 -ORANGE-</b>	Not Used
High Roller Casino †	2	090-5032-20T <b>22-900 -YELLOW-</b>	090-5032-0T <b>22-1080 -YEL-GRN-</b>	Not Used	Not Used
Austin Powers™ †	2	090-5020-30 <b>23-900 -GREEN-</b>	090-5030-0T <b>23-1100 -ORANGE-</b>	Not Used	Not Used
MONOPOLY® †	3	090-5032-0T <b>22-1080 -YEL-GRN-</b>	SAME	Not Used	090-5062-0T <b>23-1500 -BLUE-</b>
Playboy †	2	090-5030-0T <b>23-1100 -ORANGE-</b>	SAME	Not Used	Not Used
RollerCoaster Tycoon™ †	4	090-5032-0T <b>22-1080 -YEL-GRN-</b>	SAME	090-5067-0T <b>25-1400 -RED-</b>	090-5068-0T <b>25-1600 -WHITE-</b>
The Simpsons™ Pinball Party †	6** (5 with Flipper Bats)	090-5032-0T <b>22-1080 -YEL-GRN-</b>	SAME	Not Used	090-5030-0T <b>23-1100 -ORANGE-</b>
		** The Homer Head Assembly is affixed to an Upr. Rt. Style Flipper (no E.O.S. Switch):		Flippers (Mini-Bats) on 2nd Level Playfield:	
			** 090-5020-20T <b>22-900 -YELLOW-</b>	090-5041-00T <b>25-1800 -BLU-GRN-</b>	090-5025-00 <b>24-1570 -BLUE-</b>
Terminator® 3: Rise of the Machines™ †	2	090-5032-0T <b>22-1080 -YEL-GRN-</b>	SAME	Not Used	Not Used
The Lord of the Rings™ †	2	090-5020-20T <b>22-900 -YELLOW-</b>	SAME	Not Used	Not Used
Ripley's Believe It or Not!® †	3	090-5032-0T <b>22-1080 -YEL-GRN-</b>	SAME	Not Used	090-5067-00T <b>25-1400 -RED-</b>
Elvis® †	4	090-5020-20T <b>22-900 -YELLOW-</b>	SAME	090-5020-30 <b>23-900 -GREEN-</b>	SAME
The Sopranos™ †	2	090-5032-0T <b>22-1080 -YEL-GRN-</b>	SAME	Not Used	Not Used
NASCAR® and [NDSE] †	2	090-5030-0T <b>23-1100 -ORANGE-</b>	SAME	Not Used	Not Used
Grand Prix †	2	090-5030-0T <b>23-1100 -ORANGE-</b>	SAME	Not Used	Not Used
† Coil Part Numbers ending with a "T" signifies the Diode is on the top of the lug (on the coil-winding side); Coil Part Numbers ending with a "B" signifies the Diode is on the bottom of the lugs.					
** S.A.M. System Games DO NOT REQUIRE DIODES. If you use a coil from your stock which has a diode, remove it ONLY FOR S.A.M. System Games.					
World Poker Tour™ (WPT)**	4	090-5032-ND <b>22-1080 [ NO DIODE ]</b>	SAME	090-5030-ND <b>23-1100 [ NO DIODE ]</b>	SAME
©Disney's Pirates of the Caribbean**	2	090-5030-ND <b>23-1100 [ NO DIODE ]</b>	SAME	Not Used	Not Used
Family Guy™ **	3 Norm.	090-5030-ND <b>23-1100 [ NO DIODE ]</b>	SAME	090-5062-ND <b>23-1500 [ NO DIODE ]</b>	Not Used
	2 Mini	090-5046-01-ND <b>27-950 [ NO DIODE ]</b>	SAME		
Spider-Man™ **	3	090-5032-ND <b>22-1080 [ NO DIODE ]</b>	SAME	Not Used	090-5032-ND <b>22-1080 [ NO DIODE ]</b>



# APPENDIX E

## Generic Coil Cross-Reference Guide † ‡

### Flipper Coil Table ‡ ††

GAME NAME	N <sup>o</sup> of Flippers	FLIPPERS w/E.O.S. Switch		FLIPPERS no E.O.S. Switch	
		SPI N <sup>o</sup> / GAUGE-TURNS / Color		SPI N <sup>o</sup> / GAUGE-TURNS / Color	
		LOWER LEFT	LOWER RIGHT	UPPER LEFT	UPPER RIGHT
Laser War ‡	2	090-5011-00 22-750 / 30-2600	SAME	Not Used	Not Used
Secret Service ‡	3	090-5006-00 23-620 / 30-2600	SAME	Not Used	090-5006-00 23-620 / 30-2600
Torpedo Alley ‡	3	090-5011-00 22-750 / 30-2600	090-5013-00 23-700 / 30-2600	Not Used	090-5012-00 23-800 / 30-2600
Time Machine ‡	2	090-5011-00 22-750 / 30-2600	SAME	Not Used	Not Used
‡ These coils are dual-wound.					
Playboy 35th Anniversary ††	2	090-5020-02 22-900 -YEL-YEL-	SAME	Not Used	Not Used
ABC Monday Night Football ††	2	090-5020-02 22-900 -YEL-YEL-	SAME	Not Used	Not Used
†† A very small % of these games used a 090-5020-20 coil which used a proto-type Solid State Flipper System. The two types of coils both are 22-900 coils; the only difference is the addition of the 1N5404 Diode on the (-02) coils which was used in the Deger Design.					
Robocop	2	090-5020-20 22-900 -YEL-YEL-	SAME	Not Used	Not Used
Phantom of the Opera	2	090-5020-20 22-900 -YEL-YEL-	SAME	Not Used	Not Used
Back to the Future	2	090-5020-20 22-900 -YEL-YEL-	SAME	Not Used	Not Used
The Simpsons	2	090-5020-20 22-900 -YEL-YEL-	SAME	Not Used	Not Used
Checkpoint	2	090-5020-20 22-900 -YEL-YEL-	SAME	Not Used	Not Used
Teenage Mutant Ninja Turtles	2	090-5020-30 23-900 -GRN-GRN-	SAME	Not Used	Not Used
Batman	2	090-5020-30 23-900 -GRN-GRN-	SAME	Not Used	Not Used
Star Trek 25th Anniversary	2	090-5020-30 23-900 -GRN-GRN-	SAME	Not Used	Not Used
Hook	2	090-5030-00 23-1100 -ORG-ORG-	090-5020-30 23-900 -GRN-GRN-	Not Used	Not Used
Lethal Weapon 3	2	090-5030-00 23-1100 -ORG-ORG-	SAME	Not Used	Not Used
Star Wars	2	090-5032-00 22-1080 -YEL-GRN-	SAME	Not Used	Not Used
Rocky & Bullwinkle & Friends	2	090-5020-30 23-900 -GRN-GRN-	SAME	Not Used	Not Used
Jurassic Park	3	090-5020-30 23-900 -GRN-GRN-	SAME	Not Used	090-5030-00 23-1100 -ORG-ORG-

*Table continued on the next page.*



## APPENDIX E

### Flipper Coil Table †

GAME NAME	N <sup>o</sup> of Flippers	FLIPPERS w/ E.O.S. Switch		FLIPPERS no E.O.S. Switch	
		SPI N <sup>o</sup> / GAUGE-TURNS / Color		SPI N <sup>o</sup> / GAUGE-TURNS / Color	
		LOWER LEFT	LOWER RIGHT	UPPER LEFT	UPPER RIGHT
Last Action Hero	2	090-5020-30 23-900 -GRN-GRN-	SAME	Not Used	Not Used
Tales from the Crypt	3	090-5032-00 22-1080 -YEL-GRN-	SAME	Not Used	090-5041-00 25-1800 -BLU-GRN-
The Who's Tommy	3	090-5020-30 23-900 -GRN-GRN-	SAME	090-5041-00 25-1800 -BLU-GRN-	Not Used
WWF Royal Rumble	4	090-5032-00 22-1080 -YEL-GRN-	SAME	090-5041-00 25-1800 -BLU-GRN-	SAME
Guns N' Roses	3	090-5032-00 22-1080 -YEL-GRN-	SAME	090-5030-00 23-1100 -ORG-ORG-	Not Used
Maverick	3	090-5032-00 22-1080 -YEL-GRN-	SAME	Not Used	090-5032-00 22-1080 -YEL-GRN-
Mary Shelley's Frankenstein	3	090-5030-00 23-1100 -ORG-ORG-	SAME	Not Used	090-5030-00 23-1100 -ORG-ORG-
Baywatch	4	090-5030-00 23-1100 -ORG-ORG-	090-5020-30 23-900 -GRN-GRN-	090-5025-00 24-1570 -See Note-	090-5030-00 23-1100 -ORG-ORG-
Batman Forever	3	090-5032-00 22-1080 -YEL-GRN-	090-5020-20 22-900 -YEL-YEL-	Not Used	090-5020-30 23-900 -GRN-GRN-
Apollo 13	2	090-5032-00 22-1080 -YEL-GRN-	SAME	Not Used	Not Used
Golden Eye	2	090-5032-00 22-1080 -YEL-GRN-	SAME	Not Used	Not Used
Twister	2	090-5020-20 22-900 -YEL-YEL-	090-5032-00 22-1080 -YEL-GRN-	Not Used	Not Used
ID4: Independence Day	3	090-5032-00 22-1080 -YEL-GRN-	SAME	Not Used	090-5020-30 23-900 -GRN-GRN-
Space Jam †	2	090-5032-00T 22-1080 -YEL-GRN-	090-5020-20T 22-900 -YEL-YEL-	Not Used	Not Used
The Star Wars Trilogy - Special Edition †	2	090-5032-00T 22-1080 -YEL-GRN-	SAME	Not Used	Not Used
The Lost World: Jurassic Park †	2	090-5032-00T 22-1080 -YEL-GRN-	SAME	Not Used	Not Used
The X-Files †	2	090-5032-00T 22-1080 -YEL-GRN-	SAME	Not Used	Not Used
Starship Troopers †	3	090-5030-00T 23-1100 -ORG-ORG-	SAME	Not Used	090-5032-00T 22-1080 -YEL-GRN-
Viper Night Drivin' †	2	090-5030-00T 23-1100 -ORG-ORG-	SAME	Not Used	Not Used
Lost In Space †	2	090-5030-00T 23-1100 -ORG-ORG-	090-5032-00T 22-1080 -YEL-GRN-	Not Used	Not Used
Godzilla †	2	090-5032-00T 22-1080 -YEL-GRN-	SAME	Not Used	Not Used
South Park †	2	090-5030-00T 23-1100 -ORG-ORG-	SAME	Not Used	Not Used
Harley-Davidson® † and Harley-Davidson® 2nd Ed. †	2	090-5032-00T 22-1080 -YEL-GRN-	090-5030-00T 23-1100 -ORG-ORG-	Not Used	Not Used
Striker Xtreme (NFL) †	3	090-5032-00T 22-1080 -YEL-GRN-	090-5030-00T 23-1100 -ORG-ORG-	090-5030-00T 23-1100 -ORG-ORG-	Not Used
Sharkey's Shootout †	3	090-5030-00T 23-1100 -ORG-ORG-	SAME	090-5030-00T 23-1100 -ORG-ORG-	Not Used
High Roller Casino †	2	090-5020-20T 22-900 -YEL-YEL-	090-5032-00T 23-1080 -YEL-GRN-	Not Used	Not Used
Austin Powers™ †	2	090-5020-30 23-900 -GRN-GRN-	090-5030-00T 23-1100 -ORG-ORG-	Not Used	Not Used
MONOPOLY® †	3	090-5032-00T 22-1080 -YEL-GRN-	SAME	Not Used	090-5062-00T 23-1500 -BLU-BLU-
Playboy †	2	090-5030-00T 23-1100 -ORG-ORG-	SAME	Not Used	Not Used
RollerCoaster Tycoon™ †	4	090-5032-00T 22-1080 -YEL-GRN-	SAME	090-5067-00T 25-1400 -RED-RED-	090-5068-00T 25-1600 -WHT-WHT
The Simpsons™ Pinball Party †	6* (5 with Flipper Bats)	090-5032-00T 22-1080 -YEL-GRN-	SAME	Not Used	090-5030-00T 23-1100 -ORG-ORG-
		* The Homer Head Assembly is affixed to an Upr. Rt. Style Flipper (no E.O.S. Switch):		Flippers (Mini-Bats) on 2nd Level Playfield:	
			* 090-5020-20T 22-900 -YEL-YEL-	090-5041-00T 25-1800 -BLU-GRN-	090-5025-00T 24-1570 -See Note-
Terminator® 3: Rise of the Machines™ †	2	090-5032-00T 22-1080 -YEL-GRN-	SAME	Not Used	Not Used
The Lord of the Rings™ †	2	090-5020-20T 22-900 -YEL-YEL-	SAME	Not Used	Not Used
Ripley's Believe It or Not!® †	3	090-5032-00T 22-1080 -YEL-GRN-	SAME	Not Used	090-5067-00T 25-1400 -RED-RED-

† Coil Part N<sup>o</sup>s ending with a "T" signifies the Diode is on the top of the lug (on the coil-winding side); Coil Part N<sup>o</sup>s ending with a "B" signifies the Diode is on the bottom of the lugs.



# APPENDIX F

## Motor Specification (White Star Board System\* Only) Table



Game Name	Function	Specifications	Part Number
Apollo 13	Rocket Up/Down Movement	Bowman Motor 24VAC 60Hz 3W 6 RPM CCW	515-6383-00 <i>incl. Connector</i>
	Moon Unit Rotational Orbit	Multi Products Motor 24VAC 50/60Hz 3W 6 RPM CCW	515-6487-00 <i>incl. Connector</i>
	Shaker	Johnson Motor (Vibrator) 10.5VDC 10 AMP 2950 RPM CW	041-5029-00 <b>MOTOR ONLY</b>
Golden Eye	Satellite Left/Right Movement	Bowman Motor 24VAC 60Hz 3W 6 RPM CW	515-6528-00 <i>incl. Connector</i>
Twister	Spinning Disc with Magnet	Multi Products Motor 24VAC (041-5026-00) 50/60Hz 3W 325 RPM CCW	515-6347-00 <i>incl. Connector</i>
	Backbox Fan (Tornado Wind)	Multi Products Motor 24VAC (041-5052-00) 50/60Hz 3W 3600 RPM CW	515-6531-00 <i>incl. Connector</i>
ID4: Independence Day	Alien Head Open/Close Movement	Servo Motor (94322)	041-5045-00 <b>MOTOR ONLY</b>
<i>SPACE JAM (NO MOTOR USED)</i>			
The Star Wars Trilogy - S.E.	X-Wing Left/Right Movement	Bowman Motor 24VAC (041-5058-00) 60Hz 3W 10 RPM CCW	515-6383-01 <i>incl. Connector</i>
The Lost World: Jurassic Park	Snagger & Center Link Lift Up/Down Movement	Multi Products Motor 20VDC (041-5059-03) 9 RPM Non-Directional	515-6715-03 <i>incl. Connector</i>
	Shaker	Johnson Motor (Vibrator) 10.5VDC 10 AMP 2950 RPM CW	041-5029-00 <b>MOTOR ONLY</b>
The X-Files	X-File Cabinet Lift Up/Down Movement	Multi Products Motor 20VDC 9 RPM CCW	041-5057-00 <b>MOTOR ONLY</b>
Starship Troopers	Warrior Bug Forward/Reverse Movement	Haydon Switch & Instrument, Inc. Stepper Motor 12VDC 4.6W (041-5062-00), Series 36000: 1.4"ø (Non-Captive Shaft <b>not included</b> ) HSI #36864-12 (Unipolar) Travel per Step: .004 Step Angle: 15°	515-6794-00 <i>incl. Connector</i> Requires 7" Shaft: 530-5503-00
<i>VIPER NIGHT DRIVIN' (NO MOTOR USED)</i>			
Lost In Space	Spinning Disc with Magnet	Multi Products Motor 24VAC (041-5046-00) 50/60Hz 3W 325 RPM CCW	515-6347-00 <i>incl. Connector</i>
Godzilla	Shaker ‡	Multi #3811 0630 Motor (Vibrator) 12VDC 3100 RPM CW (w/DRL PTS) ‡	041-5029-01 <b>MOTOR ONLY</b>
<i>SOUTH PARK (NO MOTOR USED)</i>			
Harley-Davidson® 1st through 3rd Editions	Shaker ‡	Multi #3811 0630 Motor (Vibrator) 12VDC 3100 RPM CW (w/DRL PTS) ‡	041-5029-01 <b>MOTOR ONLY</b>
	Motorcycle Lift Up/Down Movement	Autotrol 24VAC (041-5072-02) 20 RPM CCW	515-7025-00 <i>incl. Connector</i>
Striker Xtreme (NFL)	Goalie (Linebacker) Left to Right Movement	Multi #3590 12VDC (041-5075-00) 60 RPM	515-7071-00 <i>incl. Connector</i>
Sharkey's Shootout	Mystery Ball Rotating Movement	Hankscraft Motor Model-E 24VAC (041-5076-00) 50/60Hz 3W 20 RPM CW	515-7095-00 <i>incl. Connector</i>
High Roller Casino	Roulette Wheel Rotating Movement	Multi Products Motor 20VDC (041-5078-00) 17 RPM CCW	515-7153-00 <i>incl. Connector</i>
	Up/Dn. Ramp in Slot Mach. Lift Up/Down Movement	Haydon Switch & Instrument, Inc. Stepper Motor 12VDC 4.6W (041-5062-00), Series 36000: 1.4"ø (Non-Captive Shaft <b>not included</b> ) HSI #36864-12 (Unipolar) Travel per Step: .004 Step Angle: 15°	515-6794-00 <i>incl. Connector</i> Requires Shaft 4¼": 530-5503-01
Austin Powers™	Time Machine Rotating Movement	Multi Products Motor 24VAC (041-5079-00) 50/60Hz 20RPM CCW	515-7141-00 <i>incl. Connector</i>
	Laser Beam Left to Right Directional	Autotrol Motor 24VAC (041-5081-00) 50/60Hz 4W 10RPM Bi-Directional	515-7171-00 <i>incl. Connector</i>
	Dr. Evil Target Lift Up/Down Movement	Hankscraft Motor Model-E 24VAC (041-5030-00) 50/60Hz 6RPM CCW	515-5900-00 <i>incl. Connector</i>
Monopoly®	Mini-Flipper (Waterworks) Rotating Movement	Multi Prod. Motor & Gear Box #7000 EX00159A 20VDC 50/60Hz 85RPM CC/CCW	041-5083-00 <b>MOTOR ONLY</b>
Playboy	Triangular Billboard Rotating Movement	Autotrol Motor (BD511 150-1387) 24VAC 50/60Hz 12RPM Bi-Directional	041-5086-02 <b>MOTOR ONLY</b>
	Centerfold Mechanism Open/Close Movement	Multi Products (3680) Motor 12v DC 10/12 RPM CC/CCW	041-5075-04 <b>MOTOR ONLY</b>
	Tease Drop Screen Lift Up/Down Movement	Haydon Switch & Instrument, Inc. Stepper Motor 12VDC 4.6W (041-5062-00), Series 36000: 1.4"ø (Non-Captive Shaft <b>not included</b> ) HSI #36864-12 (Unipolar) Travel per Step: .004 Step Angle: 15°	515-6794-00 <i>incl. Connector</i> Requires 7" Shaft: 530-5503-00

‡ Please Note: ".01" Shaker Motor is **Not Compatible** with old Shaker Motor 041-5029-00 (Shaker Motor Assy. 515-5893-00). THIS NEW MOTOR CAN ONLY BE USED IN NEW SHAKER MOTOR ASSY. 515-5893-01.

Table continued on the next page.





# APPENDIX F

## Motor Specification (White Star Board System\* & S.A.M. System\*\* Only) Table



Game Name	Function	Specifications	Part Number
<b>ROLLERCOASTER TYCOON™ (NO MOTOR USED)</b>			
<b>THE SIMPSONS™ PINBALL PARTY (NO MOTOR USED)</b>			
<b>Terminator® 3: Rise of the Machines™</b>	Backbox Ball Shooter Up/Down Movement	Multi Products Motor 24VAC (041-5079-01) 21 RPM CW	515-7317-00 <i>incl. Connector</i>
<b>The Lord of the Rings™</b>	Balrog (Motor & Gate) Open/Close Movement	Multi Prod. Motor 20VDC Series 600B (or equiv.) 50/60Hz 10 RPM Bi-Directional	041-5088-01 <b>MOTOR ONLY</b>
<b>RIPLEY'S BELIEVE IT OR NOT!® (NO MOTOR USED)</b>			
<b>Elvis®</b>	Elvis™ Front/Back Movement	Haydon Switch & Instrument, Inc. Stepper Motor 12VDC 10W (041-5089-00), (Non-Captive Shaft <b>not included</b> ) HSI #46868-12-002	500-6809-00 <i>incl. Connector</i> Requires 7.25" Shaft: 530-5658-00
	▶▶▶ <b>OPTIONAL</b> ◀◀◀ Shaker	Multi #3811 0630 Motor (Vibrator) 12VDC (041-5029-01) 3100 RPM (w/DRL PTS)	515-5893-01 <i>incl. Connector</i>
<b>The Sopranos™</b>	Bada Bing! Girls x2 Rotating Posts Movement	Autotrol Synchronous Motor 24VAC 4W 50/60Hz 45.7/54.9 RPM Bi-Directional	041-5092-00 <i>w/1" Shaft + 12" Leads</i>
<b>NASCAR® and [NDSE]</b>	Back Panel Rotating (Car) Windmill (Skill Ball Enter)	Multi Products Motor & Gear Box 20VDC Model #8000 (EX-04-073) 10 RPM	041-5093-00 <b>MOTOR ONLY</b>
<b>Grand Prix</b>	Back Panel Rotating (Car) Windmill (Skill Ball Enter)	Multi Products Motor & Gear Box 20VDC Model #8000 (EX-04-073) 10 RPM	041-5093-00 <b>MOTOR ONLY</b>
<b>World Poker Tour™ (WPT) (NO MOTOR USED)</b>			
<b>The Simpsons™ Kooky Carnival</b>	Bart on Skateboard Left/Right Movement	Multi Products Motor with Crank 24VAC (041-5095-01) 50/60Hz 3W 14 RPM	500-6947-01 <i>incl. Connector</i>
	Left & Right Ramps Up/Down Movement	Multi Products Motor 24VAC (041-5048-01) 50/60Hz 3W 15 RPM CCW (Qty. 2 in game)	515-7558-00 <i>incl. Connector</i>
	Shaker <i>(details in SKC Manual, Page 24)</i>	Multi #3811 0630 Motor (Vibrator) 12VDC 3100 RPM (w/DRL PTS)	041-5029-01 <b>MOTOR ONLY</b>
<b>©Disney's Pirates of the Caribbean</b>	Spinning Disk	Multi #3811R 0630 Motor (Vibrator) 12VDC (041-5029-04) 3100 RPM (w/DRL PTS) -04 is RoHS compliant; can substitute with -01 domestic	511-5024-04 <i>incl. Connector</i>
	Pirate Ship Sinking/Raising Movement	Multi Products Motor & Gear Box 24VDC Model #7000-DCM 12 RPM	041-5101-00 <b>MOTOR ONLY</b>
<b>Family Guy™</b>	Stewie Figurine Left & Right Movement	Stepper Motor NPM PF35T-48D4STD 5V RVB (041-5102-00 Reference Only)	511-5043-00 <i>incl. Connector</i>
<b>Spider-Man™</b>	Doc Ock, Sandman & 3-Bank Up/Down Movement	Sync. Motor 24VAC 50/60Hz 3W 12 RPM CW (041-5103-00 Reference Only)	511-5063-00 <i>incl. Connector</i>
	▶▶▶ <b>OPTIONAL</b> ◀◀◀ Shaker Motor Kit 502-5027-00	Multi #3811R 0630 Motor (Vibrator) 12VDC (041-5029-04) 3100 RPM (w/DRL PTS) -04 is RoHS compliant; can substitute with -01 domestic	515-5893-01 <i>incl. Connector</i>



## APPENDIX F

### Motor Specification Table

The following table only list games that used motors. Part Numbers starting with "515-" will include the Wiring Harness & Connector.

Game Name	Function	Specifications	Part N <sup>o</sup>
<b>ABC Monday Night Football</b>	Goal Post Up/Down Movement	Motor 24v A.C. 60 RPM CW	515-5222-00
<b>Phantom of the Opera</b>	Organ Up/Down Movement	Bowman Motor 24v 60Hz 3W 11 RPM CCW	515-5256-00
<b>Checkpoint</b>	Mag Wheel (in Backbox)	Motor D.C. (KEN)	041-5005-00
	Shaker	Johnson Motor (Vibrator)	041-5002-00
<b>Teenage Mutant Ninja Turtles</b>	Spinning Pizza Ball Deflector	Gear Motor 24v A.C. 325 RPM CW	515-5397-00
<b>Batman</b>	Bar Target Up/Down Movement	Bowman Motor 24v 60Hz 3W 11 RPM CCW	515-5256-00
<b>Star Trek 25th Anniversary</b>	Swinging Target	Bowman Motor 24v 22½ RPM	515-5534-00
	Transporter F/X	Gear Motor 24v A.C. 3½ RPM	500-5421-00
	Cooling Fan (for Transporter F/X)	4½" Motor 12v	041-5014-00
<b>Lethal Weapon 3</b>	Spinning Light	Motor 2½ v A.C. 4000 RPM CCW	041-5017-00
<b>Star Wars</b>	Bar Target Up/Down Movement	Bowman Motor 24v 60hz 3W 11 RPM CCW	515-5256-00
	R2D2 Robot Left/Right Movement	Bowman Motor 24v A.C. 22½ RPM CW	515-5571-00
	Death Star Rotation	Bowman "G" Motor 24v A.C. 60Hz 6 RPM CW	515-5570-00
<b>Rocky &amp; Bullwinkle &amp; Friends</b>	Nell Log "Cutting Blade" Forward/Back Movement	Autotrol Model E Motor 24v 60hz 4W 3 RPM CCW	041-5023-00
<b>Jurassic Park</b>	T-Rex Left/Right Movement	Multi Motor 5v D.C.	041-5025-00
	T-Rex Up/Down Movement	Bowman Motor 24v 11 RPM CW	041-5026-00
	Shaker	Johnson Motor (Vibrator)	041-5002-00
<b>Last Action Hero</b>	Crane Left/Right Movement	Multi Products Motor 12v D.C. #3312 OSC	041-5027-00
	Shaker	Johnson Motor (Vibrator) 10.5v D.C. 10 AMP 2950 RPM CW	041-5029-00
<b>Tales from the Crypt</b>	Tombstone Up/Down Movement	Bowman Motor 24v A.C. 6 RPM CCW	515-5900-00
	Shaker	Johnson Motor (Vibrator) 10.5v D.C. 10 AMP 2950 RPM CW	041-5029-00
<b>The Who's Tommy</b>	Mirror Up/Down Movement	Bowman Motor 24v A.C. 6 RPM CCW	515-5900-00
	Flipper Blinders	Servo Motor (94102)	041-5032-00
	Spinning Airplane Propellers	Motor D.C.	041-5033-00
<b>WWF Royal Rumble</b>	Shaker	Johnson Motor (Vibrator) 10.5v D.C. 10 AMP 2950 RPM CW	041-5029-00
<b>Maverick, The Movie</b>	Turning Paddle Wheel	Motor 24v A.C. 10 RPM	041-5036-00
<b>Mary Shelley's Frankenstein</b>	Creature Head Left/Right Movement	Servo Motor (94102)	041-5032-00
<b>Batman Forever</b>	Cannon Left/Right Movement	Bowman Motor 24v A.C. 60Hz 3W 6 RPM CCW	515-6383-00

# APPENDIX G

## Part Number Prefix Classification Codes

### I. Electrical Source, Energy & Signal Converters

- 010- Transformers
- 031- Speakers
- 090- Solenoids (Coils)
- 150- Filters, Outlets, Varistors, Thermistors
- 200- Fuses

### II. Conductors, Connectors & Insulators

- 034- Line Cords
- 036- Cable Assemblies & Wiring Harnesses
- 041- Motors
- 045- Connectors (All Types)
- 055- Lugs (M/F), Pins (M/F), Discs, Ring Terminals, Terminal Strips, etc.
- 060- Polarizing Keys and Conn. Covers
- 077- Lamp Sockets

### III. Circuits & Circuit Elements

- 100- ICs
- 110- Transistors
- 112- Diodes (All Types including LEDs & Modules)
- 121- Resistors
- 123- Resistors (Variable & Adjustable)
- 124- Regulators & Bridge Rectifiers
- 125- Capacitors (Radial Lytics & Ferrites)
- 126- Piezo Crystal
- 127- Heatsinks
- 130- Capacitors (Tectates & Ceramics)
- 140- Oscillators (Clocks/Crystals)
- 165- Light Bulbs
- 180- Switches
- 181- Switch Membranes (Pads) & Piezo Sensors
- 190- Relays
- 960- EPROM (*Raw Part*)
- 965- EPROM (*Programmed Part*)

### IV. Bolts, Screws, Nuts, Washers & Nails

- 231- Bolts
- 232- Screws (Pan Head)
- 234- Screws (HWH)
- 237- Screws (Misc.)
- 240- Nuts (Misc.)
- 242- Washers (Flat, Round)
- 244- Washers (Split Lock)
- 245- Nyloners
- 246- Washers (Lockers, External Tooth)
- 281- Nails

### V. Mechanical Components

- 249- Rivets
- 251- Pins (Dowel), Finishing Nails, Hairpins, Spring Pins and Clevis Pins
- 254- Stand-Offs, Spacers and Shims
- 260- Steel Ball (All Types Steel, Glowing, Delrin, etc.)
- 265- Springs (Extension)
- 266- Springs (Compression)
- 267- Springs (Torsion)
- 269- Springs (Washers - Belleville, Wave)
- 270- Retaining Rings
- 280- Grommets, Bushings and Nyloners
- 283- Bearings

### VI. Handles, Locks, Catches, Latches, Keys

- 355- Handles, Locks, Catches, Latches and Keys

### VII. Fabricated Parts

- 390- Hinges
- 501- Coin Doors
- 515- Sub-Assemblies
- 520- Printed Circuit Boards (PCBs)
- 522- Display Glass
- 525- Wood Parts
- 530- Screw Machined Parts
- 535- Fabricated Parts
- 545- Molded (Extruded) Plastic and Rubber Parts (Rings, Sleeves, etc.)
- 550- Molded (Inserts)

### VIII. In-House Assemblies

- 500- End Product (Systems and Models)
- 502- Kits (Created In-House)
- 505- Cabinets (complete)
- 510- Riveted Sub-Assemblies (In-House)
- 511- Sub-Assemblies (In-House)
- 515- Sub-Assemblies\*

\*2 or more 515-'s but still a sub-assembly.

### IX. Bulk Materials

- 600- Braided Wire & Ground Straps
- 601- Stranded Wire
- 602- Ribbon Cable
- 604- Telephone Line Cord
- 605- Sleeving (Shrink Tubing)
- 625- Velcro (non-adhesive)
- 626- Foam Rubber, Foam Pads, Rubber Bumpers (Blue Pads), Tape (All Types) Velcro (adhesive) and String / Rope

















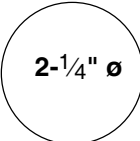
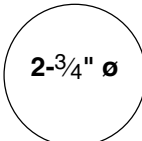
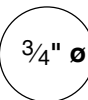
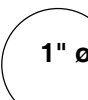
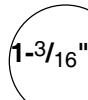
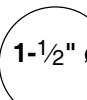
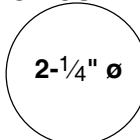
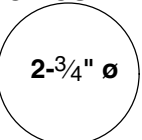

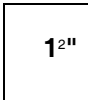
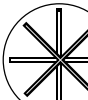
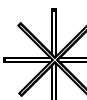
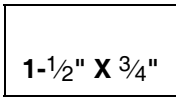
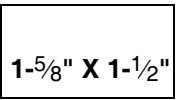
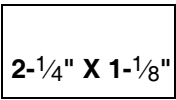
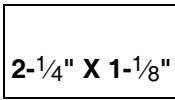
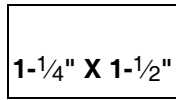
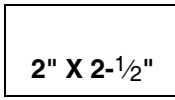
### X. Miscellaneous

- 000- Tools (*see also 777-*) and Supplies
- 040- Clamps, Ties & Clips
- 042- Pulleys
- 091- Coin Mechs
- 205- Fuse Holders
- 631- Staples
- 660- Glass (Playfield, Backglass, etc.)
- 675- Cleaners
- 705- Packing & Shipping Items
- 755- Instruction, Coin Cards, Ins. Sheets
- 756- Information Sheets, Service Bulletins, Instruction Sheets in Kits and Templates
- 777- Tools (Wrenches and Drivers)
- 780- Manuals
- 802- Decal Kits (comprised of 820's)
- 820- Decals, Mylar and Labels (Sheets/Sets)
- 803- Plastic Kits (comprised of 830's)
- 830- Plastic Pieces (Butyrate Sheets/Sets)
- 880- Toys, Models, Figurines, etc.
- 900- Game Posters

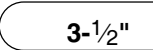

# APPENDIX H

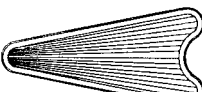
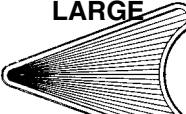
## Playfield Inserts (Plastic Light Covers)

<b>Patterns:</b> <b>STARBURST</b>  <b>STIPPLE</b> 	<b>STARBURST CIRCULAR</b>  <b>550-5000-XX</b>	<b>STARBURST CIRCULAR</b>  <b>550-5001-XX</b>	<b>STARBURST CIRCULAR</b>  <b>550-5002-XX</b>	<b>STARBURST CIRCULAR</b>  <b>550-5003-XX</b>	<b>STARBURST CIRCULAR</b>  <b>550-5004-XX</b>
<b>STARBURST CIRCULAR</b>  <b>550-5005-XX</b>	<b>STARBURST CIRCULAR</b>  <b>550-5006-XX</b>	<b>PLAIN CIRCULAR</b>  <b>550-5007-XX</b>	<b>PLAIN CIRCULAR</b>  <b>550-5008-XX</b>	<b>PLAIN CIRCULAR</b>  <b>550-5009-XX</b>	<b>PLAIN CIRCULAR</b>  <b>550-5010-XX</b>
<b>PLAIN CIRCULAR</b>  <b>550-5011-XX</b>	<b>PLAIN CIRCULAR</b>  <b>550-5012-XX</b>	<b>STIPPLE CIRCULAR</b>  <b>550-5048-XX</b>	<b>STIPPLE 1" SQUARE</b>  <b>550-5019-XX</b>	<b>ROLLOVER BUTTON BASE</b>  <b>550-5026-XX</b>	<b>WHITE STAR (only in white)</b>  <b>545-5015-00</b>
<b>STIPPLE RECTANGULAR</b>  <b>550-5018-XX</b>	<b>STIPPLE RECTANGULAR</b>  <b>550-5051-XX</b>	<b>STARBURST RECTANGULAR</b>  <b>550-5044-XX</b>	<b>PLAIN RECTANGULAR</b>  <b>550-5049-XX</b>	<b>PLAIN RECTANGULAR</b>  <b>550-5050-XX</b>	<b>PLAIN RECTANGULAR</b>  <b>550-5063-XX</b>
<b>STARBURST MINI SHIELD</b>  <b>550-5024-XX</b>	<b>STARBURST LARGE SHIELD</b>  <b>550-5025-XX</b>	<b>MINI HOT DOG</b>  <b>550-5020-XX</b>	<b>BEVEL HOT DOG</b>  <b>550-5021-XX</b>	<b>PLAIN HOT DOG</b>  <b>550-5022-XX</b>	<b>BANANA</b>  <b>550-5023-XX</b>
<b>STARBURST ARROW-SMALL</b>  <b>550-5013-XX</b>	<b>STARBURST ARROW-LARGE</b>  <b>550-5070-XX</b>	<b>STARBURST ARROW-HEAD SMALL</b>  <b>550-5014-XX</b>	<b>STARBURST ARROW-HEAD LARGE</b>  <b>550-5015-XX</b>	<b>STARBURST BULLET</b>  <b>550-5016-XX</b>	<b>STARBURST TRIANGLE</b>  <b>550-5017-XX</b>

**Note:** The shapes and sizes shown above are not to scale. Some shapes may no longer be available in every color.

**Instructions:** Parts which may come in various colors (i.e. targets, some posts, playfield inserts, etc.) end in a 2-digit number which correspond to the color of that part. The "-XX" in part number which may come in various colors should be replaced with the desired 2-Digit number corresponding to the color desired below. *Not all colors may be available.*

PLASTIC PART COLOR CHART											
Nº	Color	Nº	Color	Nº	Color	Nº	Color	Nº	Color	Nº	Color
-00	Black or Solid Clear	-03	Amber	-06	Yellow	-09	Purple	-12	Fluor. Blue	-15	Luminescent
-01	Clear	-04	Green	-07	Orange	-10	Fluor. Orange	-13	Teal Green	-16	Gold
-02	Red	-05	Blue	-08	White	-11	Fluor. Green	-14	Gray	-17	Trans. Brown



# APPENDIX I

## Stand-Up Targets

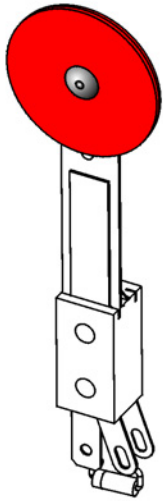

112-5003-00  
Switch Diode, 1N4004  
(all Stand-Up Targets)

**515-5966-XX**  
1" ROUND STAND-UP  
SWITCH & TARGET  
RIVETED ASSEMBLY\*

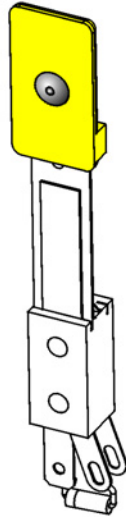

**STANDARD**  
**515-5967-XX** or **ANTI-LOFT**  
**515-7581-XX**  
1" X 1/2" NARROW STAND-UP  
SWITCH & TARGET  
RIVETED ASSEMBLY\*

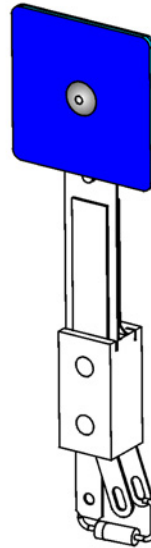

**515-5162-XX**  
1" X 1" SQUARE STAND-UP  
SWITCH & TARGET  
RIVETED ASSEMBLY\*

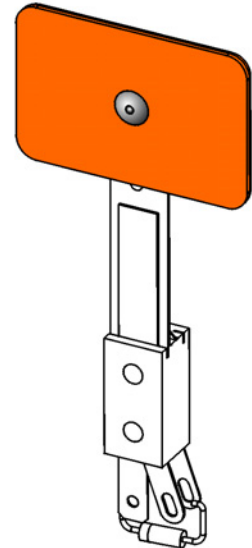

**515-6027-XX**  
1" X 1-1/2" RECTANGLE STAND-UP  
SWITCH & TARGET  
RIVETED ASSEMBLY\*

\*Note: Does not include the Switch Back Plate, Mounting Bracket or screws.

To include the Switch Back Plate, Foam Pad, and Switch Mounting Bracket assembled, use the follow assembly part numbers (replace the -XX with 2-digit number from chart):

500-5835-XX : 1" ROUND TARGET      500-5857-XX : 1" X 1/2" NARROW TARGET      500-5232-XX : 1" X 1" SQUARE TARGET      500-5321-XX : 1" X 1-1/2" RECT. TARGET

### REAR VIEW 515-5967-06 SHOWN

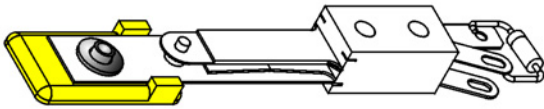

**SHOWN BELOW : 500-5857-06**  
1" X 1/2" NARROW STAND-UP  
TARGET ASSEMBLY COMPLETE

626-5029-00  
Foam Pad, Square  
.44" X .44" X .125" Thick (Self-Adhesive)\*\*

\*\* Note:  
Use with all Switch  
& Targets THIS page  
except for 515-7581-XX

535-6896-00  
Bracket, Switch  
Mounting  
(all targets THIS page)

237-5976-05  
#6-32 X 3/4" SHWH Sc.  
(all targets THIS page)

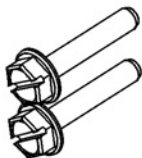

**515-5967-XX**  
1" X 1/2" NARROW  
STAND-UP (STANDARD)  
SWITCH & TARGET  
RIVETED ASSEMBLY\*

535-6452-00  
Switch Back Plate\*\*

535-6896-00  
Bracket, Switch  
Mounting  
(all targets THIS page)

237-5976-05  
#6-32 X 3/4" SHWH Sc.  
(all targets THIS page)

### -XX REPLACE WITH 2-DIGIT FOR COLOR:

- 00 Black
- 01 Clear
- 02 Red
- 03 Amber
- 04 Green
- 05 Blue
- 06 Yellow
- 07 Orange
- 08 White
- 09 Purple
- 10 Fluor. Orange
- 11 Fluor. Green
- 12 Fluor. Blue
- 13 Teal Green
- 14 Gray
- 15 Luminescent
- 16 Gold

Note: Not all colors available.

### SHOWN BELOW : 500-6985-04

1" X 1/2" NARROW ANTI-LOFT  
STAND-UP TARGET  
ASSEMBLY COMPLETE

626-5069-00  
Foam Pad, Rectangle  
.6" X .4" X .25" Thick (Self-Adhesive) ‡

‡ Note: Use only with  
515-7581-XX Switch &  
Target Assembly unless  
otherwise noted.

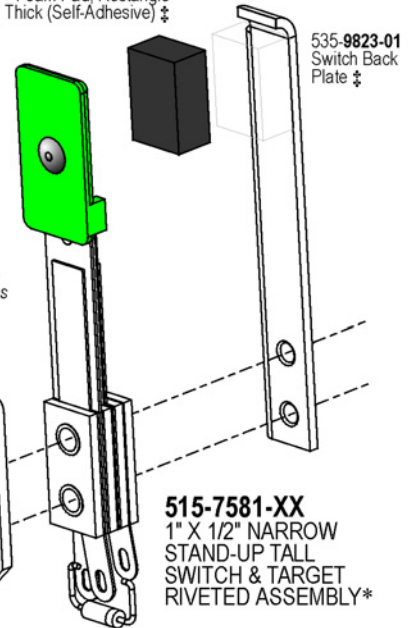

**515-7581-XX**  
1" X 1/2" NARROW  
STAND-UP TALL  
SWITCH & TARGET  
RIVETED ASSEMBLY\*

**ORDERING NOTE: 515-7581-XX (500-6985-XX)**  
differences from 515-5967-XX (500-5857-XX) are:

1. Switch & Target Taller (Target sits higher over P/F)
2. Switch Back Plate differs (bend, shape & tab)
3. Foam Pad differs (thicker, taller, different type foam)

\*Note: Does not include the Switch Back Plate, Mounting Bracket or screws.

# APPENDIX I

## Modular Stand-Up Targets

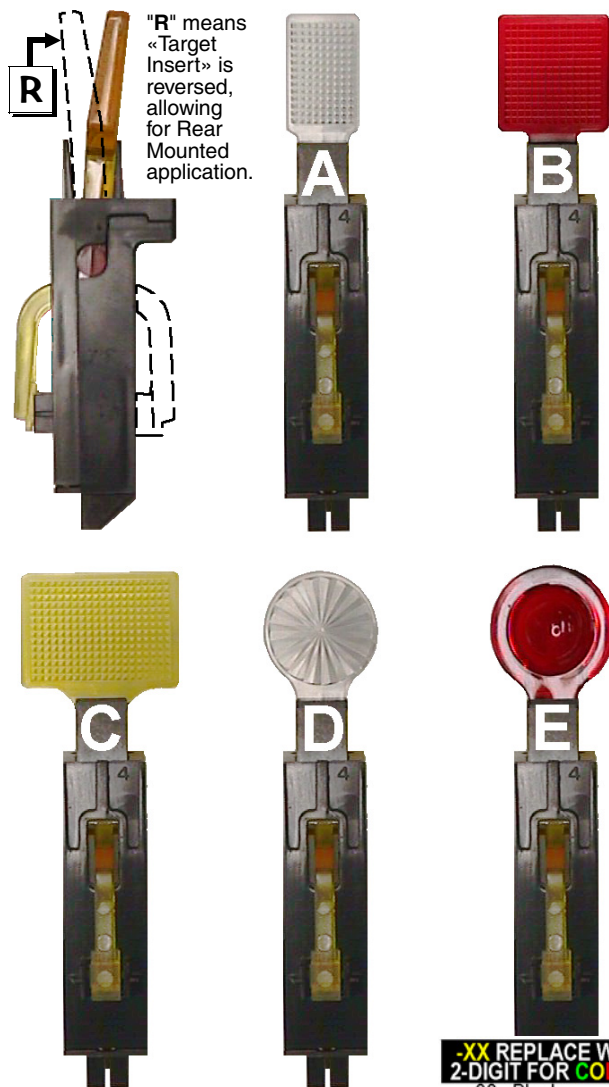

"R" means «Target Insert» is reversed, allowing for Rear Mounted application.

### To Replace the « Target Insert » or change Target Orientation :

**Items A-E Note:** For the Target Assembly use the "500-" SPI Part Number(s) shown in the Parts Table below. To receive the Target Assembly with the « Target Insert » « Reversed » simply add a "R" at the end of the Part Number. See Side View picture left to compare (dashed line shows target reversed). For just the «Target Insert» use the "545-" SPI Part Number.



### To reverse it yourself or to just change the insert:

1. With a small flat head screwdriver, push into the small tab at the bottom of the target front and give a slight twist motion to "pop" the two halves.

2. Push the Target Insert bottom in at the same time while you slide the top (front) part up, then let go of the insert as the two halves come apart.

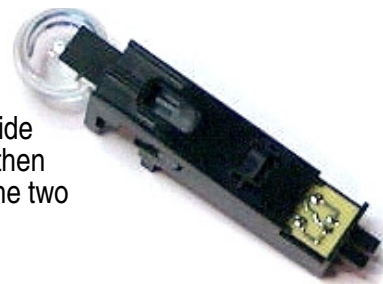

3. Replace target or reinsert it into the other size while sliding the two halves back together.

**Note:** If you were reversing the orientation, don't forget to also turn the Switch Actuator PCB 180°. Test Switch.

### Take Note:

- Items A-E come in various colors. These targets may not be available in every color. The "-XX" in should be replaced with the desired 2-Digit number for the color desired as described in the Color Chart below. As of print date, the following colors were used :  
 -01 Clear (A, D); -02 Red (A, B, C, D, E); -03 Amber (D, E);  
 -04 Green (A, B); -05 Blue (C); -06 Yellow (A, C),  
 -09 Purple (B, D); -11 Fluorescent Green (A, B, D)
- For location(s) and type of Stand-Up Targets used, if any, see Section 4, Chapter 1, Parts Identification & Location.

### -XX REPLACE WITH 2-DIGIT FOR COLOR:

- 00 Black
  - 01 Clear
  - 02 Red
  - 03 Amber
  - 04 Green
  - 05 Blue
  - 06 Yellow
  - 07 Orange
  - 08 White
  - 09 Purple
  - 10 Fluor. Orange
  - 11 Fluor. Green
  - 12 Fluor. Blue
  - 13 Teal Green
  - 14 Gray
  - 15 Luminescent
  - 16 Gold
- Note: Not all colors available.

Nr.	STAND-UP TARGET PARTS	SPI PART Nr.
A	Modular Stand-Up Target Narrow Assy.	500-6138-XX
	Stand-Up Target Narrow (Insert)	545-6138-XX
B	Modular Stand-Up Target Square Assy.	500-6139-XX
	Stand-Up Target Square (Insert)	545-6139-XX
C	Modular Stand-Up Target Rectangle Assy.	500-6228-XX
	Stand-Up Target Rectangle (Insert)	545-6228-XX
D	Modular Stand-Up Target Round Assy.	500-6075-XX
	Stand-Up Target Round (Insert)	545-6075-XX
E	Mod. Stand-Up Target 1" Spherical Assy.	500-6189-XX
	Stand-Up Target 1" Spherical (Insert)	545-6189-XX

# APPENDIX J

## Coin Cards (USA & International Pricing Defaults) ▶ For Yellow Stock add -Y to the Part Number

If more than one Pricing Scheme is available for countries listed, the **F.** listed beside the option, denotes the Factory Default Setting.  
**FOR VIEWS OF THE LATEST or OPTIONAL USA, INTERNATIONAL / EURO AND CUSTOM COIN CARDS, VISIT OUR WEBSITE.**  
 Not Shown USA 755-5400-10 Tournament Option \$2 = X1; 755-5400-11 Tournament Option \$1.50 = X1

<b>USA 10 F.</b>  755-5400-11 Front		<b>USA 10</b>  755-5400-11 Back		<b>USA 2-7 or CANADA</b>  755-5400-02 Front		<b>FOR CUSTOM PRICING †</b>  755-5400-01, -02 or -04 Back		<b>USA 3 with ToPS™</b>  755-5400-03 or -09 Front		<b>USA 5 with ToPS™</b>  755-5400-03 Back / -08 Front	
<b>AUSTRALIA 1 F.</b>  755-5406-00 Front		<b>AUSTRALIA 2</b>  755-5406-00 Back		<b>CROATIA</b>  755-5410-00 Front		<b>FOR CUSTOM PRICING †</b>  755-5410-00 Back		<b>DENMARK 1 F.</b>  755-5402-00 Front		<b>DENMARK 2</b>  755-5402-00 Back	
<b>JAPAN 1</b>  755-5408-01 Front		<b>JAPAN 2 F.</b>  755-5408-01 Back		<b>MIDDLE EAST</b>  755-5400-06 Front		<b>ANY COUNTRY CAN USE</b>  755-5400-06 Back		<b>NEW ZEALAND 1 F.</b>  755-5406-00 Back		<b>NEW ZEALAND 2</b>  755-5406-00 Front	
<b>NORWAY 1 F.</b>  755-5403-01 Front		<b>NORWAY 2</b>  755-5403-01 Back		<b>RUSSIA F.</b>  755-5411-00 Front		<b>RUSSIA (ALTERNATE)</b>  755-5411-00 Back		<b>SOUTH AFRICA</b>  755-5409-01 Front		<b>FOR CUSTOM PRICING †</b>  755-5409-01 Back	
<b>SWEDEN 1 F.</b>  755-5404-00 Front		<b>SWEDEN 2</b>  755-5404-00 Back		<b>SWITZERLAND 1 F.</b>  755-5405-00 Front		<b>SWITZERLAND 2</b>  755-5405-00 Back		<b>TAIWAN</b>  755-5412-00 Front		<b>FOR CUSTOM PRICING †</b>  755-5412-00 Back	
<b>UK 1</b>  755-5407-00 Front		<b>UK 3</b>  755-5407-00 Back		<b>UK 5 F.</b>  755-5407-01 Front		<b>FOR CUSTOM PRICING †</b>  755-5407-01 Back		<b>Appendix J Notes:</b> 1. Coin Card on Game is determined by original shipping country destination. 2. Optional Coin Card(s), are available via your distributor or via free download @ <a href="http://www.sternpinball.com/coinagecards.shtml">www.sternpinball.com/coinagecards.shtml</a> . Older style Coin Cards (foreign or domestic) not available on our website or no longer available through your distributor, are obsolete. 3. Coin Cards which have a Blank Backside can be used for †Custom Pricing.			

Not Shown EURO 755-5401-20 Tournament Custom (can fill in your own pricing).

<b>EURO 1</b>  755-5401-01 1-Side Only		<b>EURO 2</b>  755-5401-02 1-Side Only		<b>EURO 3</b>  755-5401-03 1-Side Only		<b>EURO 4</b>  755-5401-04 1-Side Only		<b>EURO 5</b>  755-5401-05 1-Side Only		<b>EURO 6</b>  755-5401-06 1-Side Only	
<b>EURO 7</b>  755-5401-07 1-Side Only		<b>EURO 8</b>  755-5401-08 1-Side Only		<b>EURO 9</b>  755-5401-09 1-Side Only		<b>EURO 10</b>  755-5401-10 1-Side Only		<b>EURO 11</b>  755-5401-11 1-Side Only		<b>EURO 12</b>  755-5401-12 1-Side Only	

### ▶ EURO FACTORY DEFAULT SUMMARY TABLE ◀

EURO 1	EURO 2	EURO 3	EURO 4	EURO 5	EURO 6	EURO 7	EURO 8	EURO 9	EURO 10	EURO 11	EURO 12
BELGIUM ITALY 1 PORTUGAL	GERMANY 2	NETHERLANDS SPAIN			GREECE		FINLAND	AUSTRIA	FRANCE		

Section 3, Chapter 4, GO TO ADJUSTMENTS MENU, Adj. 18, Game Pricing, USA & International (non-Euro) and Euro 1-12 Summary & International (Euro) Standard Pricing Select Tables, summarizes Standard or Custom Pricing Schemes & the Dip Switch Setting required.





# APPENDIX A



## Pinball Game Firmware (White Star Board System\* Only) Table

See website for the latest International Code or Updated USA version / checksums

ROM	Chip Size	Program Part N°	USA ver. & Check Sum	Bd. Loc.	Raw Part N°
<b>Apollo 13 (Note 1)</b>					
Game ROM (1M)	965-0208-00	A5.01	\$09FF	U210	960-5009-00
Sound (512K)	965-0212-00	1.00	\$5244	U7	960-7001-02
Display (4M)	965-0213-00	A5.00	\$B92B	ROM 0	960-5015-01
Voice 1 (4M)	965-0209-00	1.00	\$7FC7	U17	n/a (masked)
Voice 2 (4M)	965-0210-00	1.00	\$8E55	U21	n/a (masked)
Voice 3 (4M)	965-0211-00	1.00	\$08EE	U36	n/a (masked)
<b>Golden Eye (Note 1)</b>					
Game ROM (1M)	965-0214-42	A4.04	\$3FFF	U210	960-5009-00
Sound (512K)	965-0217-42	1.00	\$D615	U7	960-7001-02
Display (4M)	965-0218-42	A4.00	\$E6ED	ROM 0	960-5015-01
Voice 1 (4M)	965-0215-42	1.00	\$3E32	U17	n/a (masked)
Voice 2 (4M)	965-0216-42	1.00	\$71F0	U21	n/a (masked)
<b>Twister (Note 2)</b>					
Game ROM (1M)	965-0219-41	A4.05	\$E9FF	U210	960-5009-00
Sound (512K)	965-0221-41	1.00	\$1FFF	U7	960-7001-02
Display (4M)	965-0222-41	A4.00	\$FD01	ROM 0	960-5015-01
Voice 1 (4M)	965-0220-41	1.00	\$3650	U17	960-5015-01
Voice 2 (4M)	965-0223-41	1.00	\$9300	U21	960-5015-01
<b>ID4: Independence Day (Note 2)</b>					
Game ROM (1M)	965-0224-45	A2.02	\$9CFF	U210	960-5009-00
Sound (512K)	965-0227-45	1.00	\$222B	U7	960-7001-02
Display (4M)	965-0228-45	A2.00	\$AB7	ROM 0	960-5015-01
Voice 1 (4M)	965-0225-45	1.00	\$3AF1	U17	960-5015-01
Voice 2 (4M)	965-0226-45	1.00	\$206E	U21	960-5015-01
<b>Space Jam (Note 2)</b>					
Game ROM (1M)	965-0229-43	A3.00	\$E6FF	U210	960-5009-00
Sound (512K)	965-0233-43	1.00	\$F1E7	U7	960-7001-02
Display (4M)	965-0234-43	A3.00	\$0057	ROM 0	960-5015-01
Voice 1 (4M)	965-0230-43	1.00	\$DBA8	U17	960-5015-01
Voice 2 (4M)	965-0231-43	1.00	\$DDF1	U21	960-5015-01
Voice 3 (4M)	965-0232-43	1.00	\$F32A	U36	960-5015-01
<b>The Star Wars Trilogy - Special Edition (S.E.) (Note 2)</b>					
Game ROM (1M)	965-0235-56	A4.03	\$5EFF	U210	960-5009-00
Sound (512K)	965-0238-56	1.00	\$4A7D	U7	960-7001-02
Display (4M)	965-0239-56	A4.00	\$8817	ROM 0	960-5015-01
Voice 1 (4M)	965-0236-56	1.00	\$E66B	U17	960-5015-01
Voice 2 (4M)	965-0237-56	1.00	\$8F54	U21	960-5015-01
<b>The Lost World: Jurassic Park (Note 2)</b>					
Game ROM (1M)	965-0240-53	A2.02	\$C8FF	U210	960-5009-00
Sound (512K)	965-0243-53	1.00	\$A35B	U7	960-7001-02
Display (4M)	965-0244-53	A2.01	\$7F46	ROM 0	960-5015-01
Voice 1 (4M)	965-0241-53	1.00	\$1D27	U17	960-5015-01
Voice 2 (4M)	965-0242-53	1.00	\$8DA4	U21	960-5015-01
<b>The X-Files (Note 2)</b>					
Game ROM (1M)	965-0245-46	A3.03	\$A2FF	U210	960-5009-00
Sound (512K)	965-0248-46	1.00	\$65A8	U7	960-7001-02
Display (4M)	965-0249-46	A3.00	\$66D0	ROM 0	960-5015-01
Voice 1 (4M)	965-0246-46	1.00	\$349D	U17	960-5015-01
Voice 2 (4M)	965-0247-46	1.00	\$629C	U21	960-5015-01
<b>Starship Troopers (Note 3)</b>					
Game ROM (1M)	965-0250-59	A2.00	\$85FF	U210	960-5009-00
Sound (512K)	965-0253-59	1.00	\$64B2	U7	960-7001-02
Display (4M)	965-0254-59	A2.00	\$E77B	ROM 0	960-5015-01
Voice 1 (4M)	965-0251-59	1.00	\$152A	U17	960-5015-01
Voice 2 (4M)	965-0252-59	1.00	\$0291	U21	960-5015-01
Voice 3 (4M)	965-0255-59	1.00	\$95A7	U36	960-5015-01
<b>Viper Night Drivin' (Note 4)</b>					
Game ROM (1M)	965-0266-35	A2.01	\$C5FF	U210	960-5009-00
Sound (512K)	965-0271-35	1.00	\$4DF8	U7	960-7001-02
Display (4M)	965-0272-35	A2.01	\$C17D	ROM 0	960-5015-01
Voice 1 (4M)	965-0267-35	1.00	\$9018	U17	960-5015-01
Voice 2 (4M)	965-0268-35	1.00	\$2157	U21	960-5015-01
Voice 3 (4M)	965-0269-35	1.00	\$B5A6	U36	960-5015-01
Voice 4 (4M)	965-0270-35	1.00	\$D01E	U37	960-5015-01
<b>Lost In Space (Note 4)</b>					
Game ROM (1M)	965-0282-60	A1.01	\$B2FF	U210	960-5009-00
Sound (512K)	965-0287-60	1.00	\$A6AF	U7	960-7001-02
Display (4M)	965-0288-60	A1.02	\$32AB	ROM 0	960-5015-01
Voice 1 (4M)	965-0283-60	1.00	\$4391	U17	960-5015-01
Voice 2 (4M)	965-0284-60	1.00	\$8215	U21	960-5015-01
Voice 3 (4M)	965-0285-60	1.00	\$5B32	U36	960-5015-01
Voice 4 (4M)	965-0286-60	1.00	\$8971	U37	960-5015-01
<b>Godzilla (Note 4)</b>					
Game ROM (1M)	965-0289-40	A2.05	\$B1FF	U210	960-5009-00
Sound (512K)	965-0294-40	1.00	\$0CC9	U7	960-7001-02
Display (4M)	965-0295-40	A2.00	\$C929	ROM 0	960-5015-01
Voice 1 (4M)	965-0290-40	1.00	\$0D75	U17	960-5015-01
Voice 2 (4M)	965-0291-40	1.00	\$CCCF	U21	960-5015-01
Voice 3 (4M)	965-0292-40	1.00	\$227F	U36	960-5015-01
Voice 4 (4M)	965-0293-40	1.00	\$DB69	U37	960-5015-01
<b>South Park (Notes 4, 5)</b>					
Game ROM (1M)	965-0301-71	A1.03	\$58FF	U210	960-5009-00
Sound (512K)	965-0306-71	1.00	\$1286	U7	960-7001-02
Display (4M)	965-0307-71	A1.01	\$166F	ROM 0	960-5015-01
Voice 1 (8M)	965-0302-71	1.00	\$7BF8	U17	960-5016-00
Voice 2 (8M)	965-0303-71	1.00	\$9CCC	U21	960-5016-00
Voice 3 (8M)	965-0304-71	1.00	\$ADD9	U36	960-5016-00
Voice 4 (8M)	965-0305-71	1.00	\$6659	U37	960-5016-00

ROM	Chip Size	Program Part N°	USA ver. & Check Sum	Bd. Loc.	Raw Part N°
<b>Harley-Davidson® (Notes 4, 5, 6) Original (1999-2001)</b>					
Game ROM (1M)	965-0319-67	A1.03	\$3EFF	U210	960-5009-00
Sound (512K)	965-0320-67	1.00	\$F4FF	U7	960-7001-02
Display (4M)	965-0321-67	A1.04	\$FC7C	ROM 0	960-5015-01
Voice 1 (8M)	965-0322-67	1.00	\$CD26	U17	960-5016-00
Voice 2 (8M)	965-0323-67	1.00	\$3936	U21	960-5016-00
Voice 3 (8M)	965-0324-67	1.00	\$FB72	U36	960-5016-00
Voice 4 (4M)	965-0325-67	1.00	\$6100	U37	960-5015-01
<b>► Harley-Davidson® (Notes 4, 5, 6, 8) 2nd Edition (2002-2003)</b>					
Game ROM (1M)	965-0319-67A	A1.08	\$23FF	U210	960-5009-00
Display (4M)	965-0321-67A	A1.05	\$B594	ROM 0	960-5015-01
<b>► Harley-Davidson® (Notes 4, 5, 6, 8) 3rd Edition (2004)</b>					
Game ROM (1M)	965-0319-87	A4.00	\$1CFF	U210	960-5009-00
Display (4M)	965-0321-87	A4.00	\$F4FF	U5	960-5015-01
<b>Striker Xtreme (Notes 4, 5)</b>					
Game ROM (1M)	965-0326-68	A1.03	\$E4FF	U210	960-5009-00
Sound (512K)	965-0327-68	1.00	\$3BCA	U7	960-7001-02
Display (4M)	965-0328-68	A1.03	\$1957	ROM 0	960-5015-01
Voice 1 (8M)	965-0329-68	1.00	\$482A	U17	960-5016-00
Voice 2 (8M)	965-0330-68	1.00	\$7312	U21	960-5016-00
Voice 3 (8M)	965-0331-68	1.00	\$DE2F	U36	960-5016-00
Voice 4 (8M)	965-0332-68	1.00	\$C508	U37	960-5016-00
<b>NFL (Notes 4, 5) Not on CD-R or Website: Code through Distributor Only.</b>					
Game ROM (1M)	965-0339-73	A1.00	\$D2FF	U210	960-5009-00
Sound (512K)	965-0340-73	1.00	\$0000	U7	960-7001-02
Display (4M)	965-0341-73	A1.01	\$845A	ROM 0	960-5015-01
Voice 1 (8M)	965-0342-73	1.00	\$0000	U17	960-5016-00
Voice 2 (8M)	965-0343-73	1.00	\$0000	U21	960-5016-00
Voice 3 (8M)	965-0344-73	1.00	\$0000	U36	960-5016-00
Voice 4 (8M)	965-0345-73	1.00	\$0000	U37	960-5016-00
<b>Sharkey's Shootout (Notes 4, 5)</b>					
Game ROM (1M)	965-0333-72	A2.11	\$49FF	U210	960-5009-00
Sound (512K)	965-0333-72	1.01	\$9796	U7	960-7001-02
Display (4M)	965-0335-72	A2.01	\$6C33	ROM 0	960-5015-01
Voice 1 (8M)	965-0336-72	1.00	\$58EA	U17	960-5016-00
Voice 2 (8M)	965-0337-72	1.00	\$272B	U21	960-5016-00
Voice 3 (8M)	965-0338-72	1.00	\$41AE	U36	960-5016-00
<b>High Roller Casino (Notes 4, 5)</b>					
Game ROM (1M)	965-0346-65	A3.00	\$90FF	U210	960-5009-00
Sound (512K)	965-0347-65	1.00	\$581C	U7	960-7001-02
Display (4M)	965-0348-65	A3.00	\$74B3	ROM 0	960-5015-01
Voice 1 (8M)	965-0349-65	1.00	\$E12D	U17	960-5016-00
Voice 2 (8M)	965-0350-65	1.00	\$38F4	U21	960-5016-00
Voice 3 (8M)	965-0351-65	1.00	\$1B54	U36	960-5016-00
Voice 4 (8M)	965-0352-65	1.00	\$D720	U37	960-5016-00
<b>Austin Powers™ (Notes 4, 5)</b>					
Game ROM (1M)	965-0353-74	A3.02	\$5DFF	U210	960-5009-00
Sound (512K)	965-0354-74	1.00	\$D47B	U7	960-7001-02
Display (4M)	965-0355-74	A3.00	\$6A3A	ROM 0	960-5015-01
Voice 1 (8M)	965-0356-74	1.00	\$D2B9	U17	960-5016-00
Voice 2 (8M)	965-0357-74	1.00	\$9E75	U21	960-5016-00
Voice 3 (8M)	965-0358-74	1.00	\$51F3	U36	960-5016-00
Voice 4 (8M)	965-0359-74	1.00	\$0AE5	U37	960-5016-00
<b>MONOPOLY® (Notes 4, 5)</b>					
Game ROM (1M)	965-0360-75	A3.20	\$07FF	U210	960-5009-00
Sound (512K)	965-0361-75	1.00	\$8C18	U7	960-7001-02
Display (4M)	965-0362-75	A3.01	\$A381	ROM 0	960-5015-01
Voice 1 (8M)	965-0363-75	1.00	\$35E6	U17	960-5016-00
Voice 2 (8M)	965-0364-75	1.00	\$B35A	U21	960-5016-00
Voice 3 (8M)	965-0365-75	1.00	\$8A9F	U36	960-5016-00
<b>Playboy (Notes 4, 5, 7)</b>					
Game ROM (1M)	965-0367-76	A5.00	\$7DFF	U210	960-5009-00
Sound (512K)	965-0368-76	1.02	\$E7C2	U7	960-7001-02
Display (4M)	965-0369-76	A5.00	\$A5FF	ROM 0	960-5015-01
Voice 1 (8M)	965-0370-76	1.00	\$9A9E	U17	960-5016-00
Voice 2 (8M)	965-0371-76	1.00	\$9F34	U21	960-5016-00
Voice 3 (8M)	965-0372-76	1.00	\$374B	U36	960-5016-00
Voice 4 (8M)	965-0373-76	1.00	\$237A	U37	960-5016-00
<b>RollerCoaster Tycoon™ (Notes 4, 5, 7)</b>					
Sound (512K)	965-0374-78	1.00	\$F663	U7	960-7001-02
Game ROM (1M)	965-0375-78	A7.02	\$E5FF	U210	960-5009-00
Voice 1 (8M)	965-0377-78	1.00	\$3C4A	U17	960-5016-00
Voice 2 (8M)	965-0378-78	1.00	\$057A	U21	960-5016-00
Voice 3 (8M)	965-0379-7				



# APPENDIX A

## Pinball Game Firmware (White Star Board System\* & S.A.M. System\*\* Only) Table



See website for the latest International Code or Updated USA version / checksums

ROM	Chip Size	Program Part N <sup>o</sup>	USA Ver. & Check Sum	Bd. Loc.	Raw Part N <sup>o</sup>
<b>Ripley's Believe It or Not!® (Notes 7, 8)</b>					
Sound	(512K)	965-0408-81	1.00   \$D93D	U7	960-7001-02
Game ROM	(1M)	965-0409-81	<b>A3.20</b>   <b>\$43FF</b>	<b>U210</b>	960-5009-00
Voice 1	(8M)	965-0410-81	1.00   \$067B	U17	960-5016-00
Voice 2	(8M)	965-0411-81	1.00   \$C8B8	U21	960-5016-00
Voice 3	(8M)	965-0412-81	1.00   \$64C2	U36	960-5016-00
Voice 4	(8M)	965-0413-81	1.00   \$5341	U37	960-5016-00
Display	(4M)	965-0414-81	<b>A3.00</b>   <b>\$DE4B</b>	<b>U5</b> DC PCB	960-5015-01

<b>Elvis® (Notes 7, 8)</b>					
Sound	(512K)	965-0415-84	1.00   \$8CD2	U7	960-7001-02
Game ROM	(1M)	965-0416-84	<b>A5.00</b>   <b>\$50FF</b>	<b>U210</b>	960-5009-00
Voice 1	(8M)	965-0417-84	1.00   \$538D	U17	960-5016-00
Voice 2	(8M)	965-0418-84	1.00   \$8BCD	U21	960-5016-00
Voice 3	(8M)	965-0419-84	1.00   \$60F8	U36	960-5016-00
Voice 4	(8M)	965-0420-84	1.00   \$14D8	U37	960-5016-00
Display	(4M)	965-0421-84	<b>A5.00</b>   <b>\$A1F6</b>	<b>U5</b> DC PCB	960-5015-01

<b>The Sopranos<sup>SM</sup> (Notes 7, 8)</b>					
Sound	(512K)	965-0422-85	4.00   \$9B5A	U7	960-7001-02
Game ROM	(1M)	965-0423-85	<b>A5.00</b>   <b>\$5BFF</b>	<b>U210</b>	960-5009-00
Voice 1	(8M)	965-0424-85	3.00   \$F01E	U17	960-5016-00
Voice 2	(8M)	965-0425-85	1.04   \$C14C	U21	960-5016-00
Voice 3	(8M)	965-0426-85	1.04   \$47A3	U36	960-5016-00
Voice 4	(8M)	965-0427-85	1.04   \$ADCD	U37	960-5016-00
Display	(4M)	965-0428-85	<b>A5.00</b>   <b>\$B4BB</b>	<b>U5</b> DC PCB	960-5015-01

<b>NASCAR® (Notes 7, 8)</b>					
Sound	(512K)	965-0429-86	2.00   \$32B3	U7	960-7001-02
Game ROM	(1M)	965-0430-86	<b>A4.50</b>   <b>\$39FF</b>	<b>U210</b>	960-5009-00
Voice 1	(8M)	965-0431-86	2.00   \$CFFB	U17	960-5016-00
Voice 2	(8M)	965-0432-86	2.00   \$22C0	U21	960-5016-00
Voice 3	(8M)	965-0433-86	2.00   \$5FC8	U36	960-5016-00
Voice 4	(8M)	965-0434-86	2.00   \$2902	U37	960-5016-00
Display	(4M)	965-0435-86	<b>A4.00</b>   <b>\$92BD</b>	<b>U5</b> DC PCB	960-5015-01

<b>Grand Prix (Notes 7, 8)</b>					
Sound	(512K)	965-0429-91	V1.00   \$6F89	U7	960-7001-02
Game ROM	(1M)	965-0430-91	<b>A4.50</b>   <b>\$5EFF</b>	<b>U210</b>	960-5009-00
Voice 1	(8M)	965-0431-91	1.00   \$C0E2	U17	960-5016-00
Voice 2	(8M)	965-0432-91	1.00   \$F4C6	U21	960-5016-00
Voice 3	(8M)	965-0433-91	1.00   \$057D	U36	960-5016-00
Voice 4	(8M)	965-0434-91	1.00   \$2646	U37	960-5016-00
Display	(4M)	965-0435-91	<b>A4.00</b>   <b>\$DA8E</b>	<b>U5</b> DC PCB	960-5015-01

<b>[NDSE] (Notes 7, 8) <i>Call for more info if code update required.</i></b>					
Sound	(512K)	965-0436-97		U7	960-7001-02
Game ROM	(1M)	965-0437-97		<b>U210</b>	960-5009-00
Voice 1	(8M)	965-0438-97		U17	960-5016-00
Voice 2	(8M)	965-0439-97		U21	960-5016-00
Voice 3	(8M)	965-0440-97		U36	960-5016-00
Voice 4	(8M)	965-0441-97		U37	960-5016-00
Display	(4M)	965-0442-97		<b>U5</b> DC PCB	960-5015-01

**\*\* GAMES BELOW THIS LINE / NEXT COLUMN ARE S.A.M. SYSTEM GAMES**

**TO ORDER MEMORY STICK WITH GAME FILES FROM YOUR DISTRIBUTOR, USE SPI PART NUMBER 970-0128-00 & INCLUDE THE GAME NAME / LANGUAGE FILE(S) DESIRED.**

<b>World Poker Tour™ Pinball (WPT) (Notes 7, 9)</b>					
Boot B-02	(8M)	965-BOOT-SAM	1.04   \$7E62	U9	960-5016-00 unprogrammed
Memory Stick 128MB (970-0128-00)		Version		System	Bin Files:
English + Spanish		1.12AL		1.17+	WPT0112AL.bin
English Only		1.12A		1.17+	WPT0112A.bin
English + French		1.12AF		1.17+	WPT0112AF.bin
French Only		1.12F		1.17+	WPT0112F.bin
German + French		1.12GF		1.17+	WPT0112GF.bin
German Only		1.12G		1.17+	WPT0112G.bin
English + Italian		1.12AI		1.17+	WPT0112AI.bin
Italian Only		1.12I		1.17+	WPT0112I.bin

NOTE: THE TYPICAL SIZE PER UNZIPPED BIN FILE IS 25MB – 30MB+/-

<b>The Simpsons™ Kooky Carnival Redemption (Note 9)</b>					
Boot B-02	(8M)	965-BOOT-SAM	1.04   \$7E62	U9	960-5016-00 unprogrammed
Memory Stick 128MB (970-0128-00)		Version		Bin Files:	
English Only		1.05		SKC0105.bin	
English New Jersey Only		0.09NJ		SKC0090NJ.bin	

NOTE: THE TYPICAL SIZE PER UNZIPPED BIN FILE IS 5.5MB +/-

<b>©Disney's Pirates of the Caribbean Pinball (POTC) (Notes 7, 9)</b>					
Boot B-02	(8M)	965-BOOT-SAM	1.06   \$2014	U9	960-5016-00 unprogrammed
Memory Stick 128MB (970-0128-00)		Version		System	Bin Files:
English + Spanish		1.15AS		1.17+	POTC115AS.bin
English + French		1.15AF		1.17+	POTC115AF.bin
German + French		1.15GF		1.17+	POTC115GF.bin
English + Italian		1.15AI		1.17+	POTC115AI.bin

NOTE: THE TYPICAL SIZE PER UNZIPPED BIN FILE IS 25MB – 30MB+/-

<b>Family Guy™ Pinball (FG) (Notes 7, 9)</b>					
Boot B-02	(8M)	965-BOOT-SAM	2.09   \$10A3	U9	960-5016-00 unprogrammed
Memory Stick 128MB (970-0128-00)		Version		System	Bin Files:
English + Spanish		10.00AL		1.23+	FG1000AL.bin
English + French		10.00AF		1.23+	FG1000AF.bin
English + German		10.00AG		1.23+	FG1000GF.bin
English + Italian		10.00AI		1.23+	FG1000AI.bin

NOTE: THE TYPICAL SIZE PER UNZIPPED BIN FILE IS 25MB – 30MB+/-

<b>Spider-Man™ Pinball (S-M) (Notes 7, 9)</b>					
Boot B-02	(8M)	965-BOOT-SAM	2.10   \$F625	U9	960-5016-00 unprogrammed
Memory Stick 128MB (970-0128-00)		Version		System	Bin Files:
English + Spanish		1.3ES		1.27+	spd_1_30_es.bin
English + French		1.3EF		1.27+	spd_1_30_ef.bin
German + French		1.3GF		1.27+	spd_1_30_gf.bin
English + Italian		1.3EI		1.27+	spd_1_30_ei.bin

NOTE: THE TYPICAL SIZE PER UNZIPPED BIN FILE IS 25MB – 30MB+/-

### footnotes:

- 1 ROMs on CPU/Sound Bd.: 520-5136-00 (Stereo) & Display Cont. Bd.: 520-5055-01
- 2 ROMs on CPU/Sound Bd.: 520-5136-10 (Mono) & Display Cont. Bd.: 520-5055-01
- 3 ROMs on CPU/Sound Board: 520-5136-15\* (Mono) (\*FCC 11-97) & Display Controller Board: 520-5055-02\* (\*FCC 11-97)



# APPENDIX A

## Pinball Game Firmware Table

EPROM	Chip Size	Program Part N <sup>o</sup>	USA Ver.	Bd. Loc.	Raw Part N <sup>o</sup>	EPROM	Chip Size	Program Part N <sup>o</sup>	USA Ver.	Bd. Loc.	Raw Part N <sup>o</sup>
<b>Laser War</b>						<b>Lethal Weapon 3</b>					
CPU	(256K)	965-0004-00	LWAR.C5	C5	960-5007-00	CPU	(512K)	965-0082-00	A2.08	C5	960-7001-02
Sound (old)	(256K)	965-0005-00		J5	960-5007-00	Voice 1	(2M)	965-0083-00		U17	960-5010-00
Sound (old)	(256K)	965-0006-00		J6	960-5007-00	Voice 2	(2M)	965-0084-00		U21	960-5010-00
Sound (old)	(256K)	965-0007-00		J7	960-5007-00	Sound	(256K)	965-0085-00		U7	960-5007-00
			- OR -			Display	(2M)	965-0086-00	A2.06	ROM 0	960-5010-00
Sound	(256K)	965-0008-00		7F	960-5007-00	Display	(2M)	965-0087-00	A2.06	ROM 1	960-5010-00
Sound 1	(512K)	965-0009-00		6F	960-7001-02	(Used on Display PCB 520-5055-00)					
Sound 2	(512K)	965-0010-00		4F	960-7001-02	Display	(4M)	965-0087-04	-OR- A2.06	ROM 0	960-5015-00
<b>Secret Service</b>						(Used on Display PCB 520-5055-01)					
CPU	(256K)	965-0011-00	A4-6	B5	960-5007-00	<b>Star Wars</b>					
CPU	(256K)	965-0012-00	A4-6	C5	960-5007-00	CPU	(512K)	965-0119-00	A1.03	C5	960-7001-02
Voice 1	(512K)	965-0014-00		6F	960-7001-02	Voice 0	(4M)	965-0132-00		U17	960-5015-00
Voice 2	(512K)	965-0015-00		4F	960-7001-02	Voice 1	(2M)	965-0133-00		U21	960-5010-00
Sound	(256K)	965-0013-00		7F	960-5007-00	Sound	(256K)	965-0131-00		U7	960-5007-00
<b>Torpedo Alley</b>						<b>Rocky &amp; Bullwinkle &amp; Friends</b>					
CPU	(256K)	965-0016-00	A2-1	B5	960-5007-00	CPU	(512K)	965-0138-00	A1.30	C5	960-7001-02
CPU	(256K)	965-0017-00	A2-1	C5	960-5007-00	Voice 0	(4M)	965-0139-00		U17	960-5015-00
Voice 1	(512K)	965-0018-00		6F	960-7001-02	Voice 1	(2M)	965-0140-00		U21	960-5010-00
Voice 2	(512K)	965-0020-00		4F	960-7001-02	Sound	(256K)	965-0141-00		U7	960-5007-00
Sound	(256K)	965-0018-00		7F	960-5007-00	Display	(4M)	965-0142-00	A1.30	ROM 0	960-5015-00
<b>Time Machine</b>						<b>Jurassic Park</b>					
CPU	(128K)	965-0021-00	A2-4	B5	960-5006-00	CPU	(512K)	965-0143-00	A5.13	C5	960-7001-02
CPU	(256K)	965-0022-00	A2-4	C5	960-5007-00	Voice 0	(4M)	965-0144-00		U17	960-5015-00
Voice 1	(512K)	965-0024-00		6F	960-7001-02	Voice 1	(2M)	965-0145-00		U21	960-5010-00
Voice 2	(512K)	965-0025-00		4F	960-7001-02	Sound	(256K)	965-0146-00		U7	960-5007-00
Sound	(256K)	965-0023-00		7F	960-5007-00	Display	(4M)	965-0147-00	A5.10	ROM 0	960-5015-00
<b>Playboy 35th Anniversary</b>						<b>Last Action Hero</b>					
CPU	(256K)	965-0046-00	A2-4	B5	960-5007-00	CPU	(512K)	965-0148-00	A1.12	C5	960-7001-02
CPU	(256K)	965-0047-00	A2-4	C5	960-5007-00	Voice 0	(4M)	965-0149-00		U17	960-5015-00
Voice 1	(512K)	965-0049-00		6F	960-7001-02	Voice 1	(2M)	965-0150-00		U21	960-5010-00
Voice 2	(512K)	965-0050-00		4F	960-7001-02	Sound	(256K)	965-0151-00		U7	960-5007-00
Sound	(256K)	965-0048-00		7F	960-5007-00	Display	(4M)	965-0152-00	A1.06	ROM 0	960-5015-00
<b>ABC Monday Night Football</b>						<b>Tales from the Crypt</b>					
CPU	(128K)	965-0031-00	A2-7	B5	960-5006-00	CPU	(512K)	965-0157-00	A3.03	C5	960-7001-02
CPU	(256K)	965-0032-00	A2-7	C5	960-5007-00	Voice 0	(4M)	965-0158-00		U17	960-5015-00
Voice 1	(512K)	965-0034-00		6F	960-7001-02	Voice 1	(2M)	965-0159-00		U21	960-5010-00
Voice 2	(512K)	965-0035-00		4F	960-7001-02	Sound	(256K)	965-0160-00		U7	960-5007-00
Sound	(256K)	965-0033-00		7F	960-5007-00	Display	(4M)	965-0161-00	A3.01	ROM 0	960-5015-00
<b>Robocop</b>						<b>The Who's Tommy</b>					
CPU	(256K)	965-0036-00	A3-4	B5	960-5007-00	CPU	(512K)	965-0162-00	A4.00	C5	960-7001-02
CPU	(256K)	965-0037-00	A3-4	C5	960-5007-00	Voice 1	(4M)	965-0165-00		U17	960-5015-00
Voice 1	(512K)	965-0039-00		6F	960-7001-02	Voice 2	(4M)	965-0166-00		U21	960-5010-00
Voice 2	(512K)	965-0040-00		4F	960-7001-02	Voice 3	(4M)	965-0167-00		U36	960-5015-00
Sound	(256K)	965-0038-00		7F	960-5007-00	Voice 4	(4M)	965-0168-00		U37	960-5015-00
<b>Phantom of the Opera</b>						<b>WWF Royal Rumble</b>					
CPU	(128K)	965-0026-00	A3-2	B5	960-5006-00	CPU	(512K)	965-0169-00	A1.06	C5	960-7001-02
CPU	(256K)	965-0027-00	A3-2	C5	960-5007-00	Voice 1	(4M)	965-0172-00		U17	960-5015-00
Voice 1	(512K)	965-0029-00		6F	960-7001-02	Voice 2	(4M)	965-0173-00		U21	960-5015-00
Voice 2	(512K)	965-0030-00		4F	960-7001-02	Voice 3	(4M)	965-0174-00		U36	960-5015-00
Sound	(256K)	965-0028-00		7F	960-5007-00	Sound	(512K)	965-0171-00	A1.02	U7	960-7001-02
<b>Back to the Future</b>						<b>Guns N' Roses</b>					
CPU	(256K)	965-0041-00	A2-0	B5	960-5007-00	CPU	(512K)	965-0175-00	A3.00	C5	960-7001-02
CPU	(256K)	965-0042-00	A2-0	C5	960-5007-00	Voice 1	(4M)	965-0178-00		U17	960-5015-00
Voice 1	(512K)	965-0044-00		6F	960-7001-02	Voice 2	(4M)	965-0179-00		U21	960-5010-00
Voice 2	(512K)	965-0045-00		4F	960-7001-02	Voice 3	(4M)	965-0180-00		U36	960-5015-00
Sound	(256K)	965-0043-00		7F	960-5007-00	Voice 4	(4M)	965-0181-00		U37	960-5015-00
<b>The Simpsons</b>						<b>Maverick *</b>					
CPU	(128K)	965-0051-00	A2-7	B5	960-5006-00	CPU	(512K)	965-0182-00	A4.04	C5	960-7001-02
CPU	(256K)	965-0052-00	A2-7	C5	960-5007-00	Voice 1	(4M)	965-0186-00		U17	960-5015-00
Voice 1	(512K)	965-0054-00		6F	960-7001-02	Voice 2	(4M)	965-0187-00		U21	960-5015-00
Voice 2	(512K)	965-0055-00		4F	960-7001-02	Voice 3	(4M)	965-0187-01		U36	960-5015-00
Sound	(256K)	965-0053-00		7F	960-5007-00	Sound	(512K)	965-0185-00		U7	960-7001-02
<b>Checkpoint</b>						<b>Mary Shelley's Frankenstein *</b>					
CPU	(128K)	965-0056-00	A1-7	B5	960-5006-00	CPU	(512K)	965-0188-00	A1.03	C5	960-7001-02
CPU	(256K)	965-0134-00	A1-7	C5	960-5007-00	Voice 1	(4M)	965-0192-00		U17	960-5015-00
Voice 1	(1M)	965-0057-00		F7	960-5009-00	Voice 2	(4M)	965-0193-00		U21	960-5015-00
Voice 2	(1M)	965-0058-00		F5	960-5009-00	Voice 3	(4M)	965-0194-00		U36	960-5015-00
Sound	(256K)	965-0059-00		F4	960-5007-00	Sound	(512K)	965-0191-00	A1.03	U7	960-7001-02
Display	(512K)	965-0060-00	CP80	U8	960-7001-02	Display*	(4M)	965-0189-00	A1.03	ROM 0	960-5015-00
<b>Teenage Mutant Ninja Turtles</b>						<b>Baywatch *</b>					
CPU	(128K)	965-0061-00	A1.04	B5	960-5006-00	(CPU Board 520-5003-04)					
CPU	(256K)	965-0062-00	A1.04	C5	960-5007-00	CPU	(512K)	965-0195-00	A4.00	C5	960-7001-02
Voice 1	(1M)	965-0063-00		F5/6	960-5009-00	Voice 1	(4M)	965-0196-00		U17	960-5015-00
Voice 2	(1M)	965-0064-00		F4/5	960-5009-00	Voice 2	(4M)	965-0197-00		U21	960-5015-00
Sound	(256K)	965-0065-00		F7	960-5007-00	Sound	(512K)	965-0199-00		U7	960-7001-02
Display	(512K)	965-0066-00	A1.04	U8	960-7001-02	Display*	(4M)	965-0200-00	A4.00	ROM 0	960-5015-00
<b>Batman</b>						<b>Batman Forever *</b>					
CPU	(128K)	965-0067-00	A1.06	B5	960-5006-00	(CPU Board 520-5003-04)					
CPU	(256K)	965-0135-00	A1.06	C5	960-5007-00	CPU	(512K)	965-0202-00	A3.02	C5	960-7001-02
Voice 1	(2M)	965-0068-00		U17	960-5010-00	Voice 1	(4M)	965-0203-00		U17	960-5015-00
Voice 2	(2M)	965-0069-00		U21	960-5010-00	Voice 2	(4M)	965-0204-00		U21	960-5015-00
Sound	(256K)	965-0070-00		U7	960-5009-00	Sound	(512K)	965-0205-00		U7	960-7001-02
Display	(1M)	965-0071-00	A1.06	U8	960-5009-00	Display*	(4M)	965-0206-00	A3.00	ROM 0	960-5015-00
<b>Star Trek 25th Anniversary</b>						<b>Hook</b>					
CPU	(512K)	965-0072-00	A2.01	C5	960-7001-02	CPU	(512K)	965-0077-00	A4.08	C5	960-7001-02
Voice 1	(2M)	965-0073-00		U17	960-5010-00	Voice 1	(2M)	965-0078-00		U17	960-5010-00
Voice 2	(2M)	965-0074-00		U21	960-5010-00	Voice 2	(2M)	965-0079-00		U21	960-5010-00
Sound	(256K)	965-0075-00		U7	960-5007-00	Sound	(256K)	965-0080-00		U7	960-5010-00
Display	(1M)	965-0076-00	A1.09	U8	960-5009-00	Display	(1M)	965-0081-00	A4.01	U8	960-5009-00

\* Note: Display EPROMS (4M) for Maverick thru Batman Forever require an access time of 120 Nsec or faster.



## APPENDIX B

### Semi-Conductors / Integrated Circuits (I.C.) / Relays Cross-Reference Table

Table No	Type	Source Number	STERN® PINBALL	N T E®	E C G®	Radio Shack®	R C A®
<b>RECTIFICATION, BLOCKING, DAMPENING DIODES AND/OR LIGHT EMITTING DIODES (LEDs)</b>							
<b>1</b>	Diode	1N4001	112-5001-00	NTE552	ECG552	- - - - -	SK9000
	Diode	1N4004	112-5003-00	NTE116	ECG116	276-1103	SK3312
	Diode	1N5401	112-0056-00	NTE5801	ECG5801	276-1143	SK9004
	Diode	1N5404	112-5004-00	NTE5804	ECG5804	276-1144	SK9007
	Diode	T6A10L	112-5006-01	NTE5812	ECG5812	- - - - -	- - - - -
	Diode	FR302	112-5009-00	NTE588	ECG588	- - - - -	SK5014
	Diode, Signal	1N914	112-5014-00	- - - - -	- - - - -	- - - - -	- - - - -
	LED	<b>MT5000UR</b> or <b>TLRH180P</b> (T1-3/4 GaAlAs)	165-5052-00 <i>(old SPI Part No: 165-5100-00)</i>	- - - - -	- - - - -	276-066B	- - - - -
<b>ZENER DIODES</b>							
<b>2</b>	Diode	1N4742A 12v	112-0061-00	NTE142A	ECG142A	276-563	SK12V
	Diode	1N4760B 68v	112-0062-00B	NTE5092A	ECG5092A	- - - - -	SK68V
	Diode	1N4764A 100v	112-0049-00A	NTE5096A	ECG5096A	- - - - -	SK100V
	Diode	1N5228 3.9v	112-0053-00	NTE5007A	ECG5007A	- - - - -	SK3A9
	Diode	1N5234B 6.2v	112-0047-00B	NTE5013A	ECG5013A	276-561	SK6A2
	Diode	1N5379 110v	112-0072-00	NTE5157	ECG5157	- - - - -	SK110X
	Diode	1N6267A 6.8v	112-5011-00	NTE4902	ECG4902	- - - - -	- - - - -
	Diode	1N4752A 33v	112-5010-00A	NTE147A	ECG147A	- - - - -	SK33V
	Diode	1N4736 6.8v 1w	112-5007-00	NTE5071A	ECG5071A	- - - - -	- - - - -
<b>TRANSISTORS - TYPE FET, NPN, PNP AND/OR SCR</b>							
<b>3</b>	FET Trans.	STP20N10L	110-0106-00	NTE2987	ECG2987	- - - - -	- - - - -
	FET Trans.	STP19N06L	110-0088-00	NTE2985	ECG2985	- - - - -	- - - - -
	FET Trans.	VN02N	110-0089-00	- - - - -	- - - - -	- - - - -	- - - - -
	NPN Trans.	2N4401	110-0073-00	NTE85	ECG85	276-2009	SK3124A
	NPN Trans.	2N6427	110-0070-00	NTE48	ECG48	- - - - -	SK4906
	NPN Trans.	MJE340	110-0071-00	NTE157	ECG157	- - - - -	SK3747
	NPN Trans.	MPSA42	110-0082-00	NTE287	ECG287	- - - - -	SK3232
	NPN Trans.	2N3904	110-0069-00	NTE123AP	ECG123AP	276-2009	- - - - -
	NPN Trans.	TIP122	110-0067-00	NTE261	ECG261	276-2068	SK3896
	NPN Trans.	MJE15030	110-0101-00	NTE375	ECG375	- - - - -	SK9118
	PNP Trans.	2N5401	110-0078-00	NTE288	ECG288	- - - - -	SK3434
	PNP Trans.	MJE15031	110-0103-00	NTE292	ECG292	- - - - -	SK3441
	PNP Trans.	MJE350	110-0072-00	NTE374	ECG374	- - - - -	SK9042
	PNP Trans.	MPSA92	110-0100-00	NTE288	ECG278	- - - - -	SK3434
	PNP Trans.	TIP42	110-0068-00	NTE332	ECG332	- - - - -	SK9236
	PNP Trans.	TIP32C	110-0081-00	NTE292	ECG292	- - - - -	SK3441
	PNP Trans.	TIP36C	110-0077-00	NTE393	ECG393	- - - - -	SK3961
	SCR Trans.	2N5060	110-0074-00	NTE5400	ECG5400	276-1067	SK3950
SCR Trans.	SCR2800B	110-0083-00	NTE5461-8	ECG5461-8	- - - - -	- - - - -	
<b>BRIDGE RECTIFIERS (BR)</b>				<b>Comments:</b>			
<b>4</b>	BR (Present)	DB3501 or CM3501	112-5000-00	For White Star I/O Bds., BR = 35 Amp @ 100v P.I.V.			
	<b>RELAYS</b>				<b>Comments:</b>		
<b>5</b>	Relay	FRL-264 D024/02CK	190-5002-00	For PPB, Power Supply, & White Star I/O Boards, Relay = 24v DC 10 Amp DPDT			
	Relay	FRL-264 D006/04CV	190-5001-00	For CPU Boards, Relay = 6v DC 5 Amp 4 Pole DT			





# APPENDIX C

## Production Start Date, Manual Part No., ROM Size & Positions and Jumper W6 Installed Note‡ (White Star Board System & S.A.M. System Only\*)



Game Name White Star Bd. System™	Production Start Date and Manual Part Nr.	CPU/Sound Board Sound U7 512K CPU/Sound Board Game U210 1MB CPU/Sound Board Voice ROMS:				Jumper Installed (‡ see Note)	
		U17	U21	U36	U37		
* Note: For complete Appendix Information for Games <b>Laser War</b> through <b>Batman Forever</b> , see any Service Game Manual between <b>Apollo 13</b> through <b>Ripley's Believe It or Not!</b> or on-line at our website <a href="http://www.sternpinball.com/parts.htm">www.sternpinball.com/parts.htm</a> ; also available on CD-R, 970-2003-00 ( <b>The Simpsons™ Pinball Party</b> , <b>T3®</b> and <b>The Lord of the Rings™</b> ).							
29	Apollo 13 (A13)	NOV 95 780-5044-00	4MB	4MB	4MB	Not Used	n / a
30	Golden Eye	FEB 96 780-5042-00	4MB	4MB	Not Used	Not Used	n / a
31	Twister	APR 96 780-5041-00	4MB	4MB	Not Used	Not Used	n / a
32	ID4: Independence Day	JUL 96 780-5045-00	4MB	4MB	Not Used	Not Used	n / a
33	Space Jam	OCT 96 780-5043-00	4MB	4MB	4MB	Not Used	n / a
34	The Star Wars Trilogy - Sp. Ed.	FEB 97 780-5056-00	4MB	4MB	Not Used	Not Used	n / a
35	The Lost World: Jurassic Park	JUN 97 780-5053-00	4MB	4MB	Not Used	Not Used	n / a
36	The X-Files	AUG 97 780-5046-00	4MB	4MB	Not Used	Not Used	n / a
37	Starship Troopers	NOV 97 780-5059-00	4MB	4MB	4MB	Not Used	n / a
38	Viper Night Drivin'	FEB 98 780-5035-00	4MB	4MB	4MB	4MB	n / a
39	Lost In Space	JUN 98 780-5060-00	4MB	4MB	4MB	4MB	n / a
40	Godzilla	SEP 98 780-5040-00	4MB	4MB	4MB	4MB	n / a
41	South Park	JAN 99 780-5071-00	8MB	8MB	8MB	8MB	W6
42 a	Harley-Davidson®	AUG 99 780-5067-01	8MB	8MB	8MB	8MB	W6
42 b	Harley-Davidson® 2nd Ed.	SEP 02 780-5067-10	8MB	8MB	8MB	8MB	W6
42 c	Harley-Davidson® 3rd Ed.	OCT 04 780-5087-00	8MB	8MB	8MB	8MB	W6
43 a	Striker Xtreme	MAR 00 780-5068-01	8MB	8MB	8MB	8MB	W6
43 b	NFL	OCT 00 780-5073-00	8MB	8MB	8MB	8MB	W6
44	Sharkey's Shootout	JUL/OCT 00 780-5072-01	8MB	8MB	8MB	Not Used	W6
45	High Roller Casino	JAN 01 780-5065-00	8MB	8MB	8MB	8MB	W6
46	Austin Powers™	MAY 01 780-5074-00	8MB	8MB	8MB	8MB	W6
47	MONOPOLY®	SEP 01 780-5075-00	8MB	8MB	8MB	Not Used	W6
48	Playboy	FEB 02 780-5076-00	8MB	8MB	8MB	8MB	W6
49	RollerCoaster Tycoon™	AUG 02 780-5078-00	8MB	8MB	8MB	Not Used	W6
50	The Simpsons™ Pinball Party	JAN 03 780-5077-00	8MB	8MB	8MB	8MB	W6
51	T3®: Rise of the Machines™	MAY 03 780-5079-00	8MB	8MB	8MB	8MB	W6
52	The Lord of the Rings™	NOV 03 780-5080-00	8MB	8MB	8MB	8MB	
53	Ripley's Believe It or Not!®	APR 04 780-5081-00	8MB	8MB	8MB	8MB	

‡ Additional Information for **Installed Jumper** (above games 41-51):

• Installed **W6** so 8MB ROMS can be utilized. See the **CPU/Sound Board Schematic** (Sheet 2 of 3, Address Location 3E) in the games' Service Game Manual. Games 52 - 57 CPU/Sound Board differ than <51 (See Appendix D).

See **Apdx. A** for more detailed information on **Pinball Game Firmware** (ROM Name, Size, Part Numbers, USA Version & Checksum and Board Locations).

Game Name White Star Board System™	Production Start Date and Manual Part Nr.	CPU/Sound Board Sound U7 512K CPU/Sound Board Game U210 1MB CPU/Sound Board Voice ROMS:				
		U17	U21	U36	U37	
54	Elvis®	AUG 04 780-5084-00	8MB	8MB	8MB	8MB
55	The Sopranos™	FEB 05 780-5085-00	8MB	8MB	8MB	8MB
56	NASCAR®	JUL 05 780-5086-00	8MB	8MB	8MB	8MB
57	Grand Prix	SEP 05 780-5091-00	8MB	8MB	8MB	8MB

See **Apdx. A** for more detailed information on **Pinball Game Firmware** (ROM Name, Size, Part Numbers, USA Version & Checksum and Board Locations).

Game Name S.A.M. System	Production Start Date and Manual Part Nr.	S.A.M. System CPU/Sound Board Boot EPROM U9			
		965-BOOT-SAM (Programmed)			
58	World Poker Tour™ (WPT)	JUN 06 780-5088-00	8MB	B-02 V2.1+ chksum \$F625	LOC: U9
59	The Simpsons™ Kooky Carnival	APR 06 780-5090-00	8MB	B-02 V2.1+ chksum \$F625	LOC: U9
60	©Disney's Pirates of the Caribbean	AUG 06 780-5092-00	8MB	B-02 V2.1+ chksum \$F625	LOC: U9
61	Famil Guy™	DEC 06 780-5093-00	8MB	B-02 V2.1+ chksum \$F625	LOC: U9
62	Spider-Man™	MAY 07 780-5094-00	8MB	B-02 V2.1+ chksum \$F625	LOC: U9

**Games 58 – current, S.A.M. System** : CPU/Sound & I/O Power Driver PCBs differ than White Star (previous Games 29 – 57); Disp. Controller Not Required.







# APPENDIX D

## Board Type (White Star Board System\* Only) Table



Game Name	Flipper	I/O Power Driver	CPU/Sound Stereo	Disp. Power Supply	Dot Matrix Display	Display Controller	OPTO Transmitter	OPTO Receiver	OPTO Application
Apollo 13	520-5080-00 2-Flipper	520-5137-00	520-5136-00	520-5138-00	520-5052-00 128 X 32 Dots	520-5055-01	520-5124-00 Single OPTO	520-5125-00 Single OPTO	5-Ball Trough over Up-Kicker
	Miscellaneous PC Boards:	Light Boards 520-5130-01, -04 & -05 Magnet Interface, 7-Segment Display & Light Bd. 520-5130-06 Magnet Driver Board 520-5130-02 Switch Membrane Board 520-5130-03				Relay Board 520-5010-00			
Golden Eye	520-5080-00 2-Flipper	520-5137-00	520-5136-00	520-5138-00	520-5052-00 128 X 32 Dots	520-5055-01	520-5124-00 Single OPTO	520-5125-00 Single OPTO	5-Ball Trough over Up-Kicker
	Miscellaneous PC Boards:	Light Boards 520-5128-05 through -08		Mag. Processor X2 Driver Bd. 520-5143-00	Relay Board 520-5010-00				

GAMES HEREON NO LONGER REQUIRE THE FLIPPER BOARD WITH THE WHITE STAR BOARD SYSTEM™

Game Name	I/O Power Driver	CPU/Sound Mono	Disp. Power Supply	Dot Matrix Display	Display Controller	OPTO Transmitter	OPTO Receiver	OPTO Application	Misc OPTO & App.
Twister	520-5137-01	520-5136-10	520-5138-00	520-5052-00 128 X 32 Dots	520-5055-01	520-5124-00 Single OPTO	520-5125-00 Single OPTO	5-Ball Trough over Up-Kicker	
	Miscellaneous PC Boards:	Light Boards 520-5145-01 through -07		Mag. Drv. Bd. 520-5143-00	Relay Board 520-5010-00				
Independence Day (ID4)	520-5137-01	520-5136-10	520-5138-00	520-5052-00 128 X 32 Dots	520-5055-01	520-5124-00 Single OPTO	520-5125-00 Single OPTO	4-Ball Trough over Up-Kicker	
	Miscellaneous PC Boards:	Light Boards 520-5149-01 through -10		Servo Mtr. Bd. 520-5152-00		520-5082-00 Long Hop OPTO	520-5083-00 Long Hop OPTO	Alien Head Enter	
Space Jam	520-5137-01	520-5136-10	520-5138-00	520-5052-00 128 X 32 Dots	520-5055-01	520-5124-00 Single OPTO	520-5125-00 Single OPTO	5-Ball Trough over Up-Kicker	
	Miscellaneous PC Boards:	2X 7-Segment Display Board 520-5153-00							
The Star Wars Trilogy - Special Ed.	520-5137-01	520-5136-10	520-5138-00	520-5052-00 128 X 32 Dots	520-5055-01	520-5124-00 Single OPTO	520-5125-00 Single OPTO	4-Ball Trough over Up-Kicker	
	Miscellaneous PC Boards:	Relay Board 520-5010-00							
The Lost World: J.P.	520-5137-01	520-5136-10	520-5138-00	520-5052-00 128 X 32 Dots	520-5055-01	520-5124-00 Single OPTO	520-5125-00 Single OPTO	4-Ball Trough over Up-Kicker	520-5162-00 2-Pos. Motor Sensor on Snagger Motor
	Miscellaneous PC Boards:	DC Relay Bd. 520-5066-00	Shaker Mtr. Bd. 520-5065-00						
The X-Files	520-5137-01	520-5136-10	520-5138-00	520-5052-00 128 X 32 Dots	520-5055-01	520-5124-00 Single OPTO	520-5125-00 Single OPTO	4-Ball Trough over Up-Kicker	520-5155-00 3-Pos. Motor Sensor on File Cab. Motor
	Miscellaneous PC Boards:					520-5082-00 Long Hop OPTO	520-5083-00 Long Hop OPTO	File Cabinet Enter	
Starship Troopers	520-5137-01	520-5136-15	520-5138-00	520-5052-00 128 X 32 Dots	520-5055-02	520-5124-00 Single OPTO	520-5125-00 Single OPTO	4-Ball Trough over Up-Kicker	
	Miscellaneous PC Boards:	4X 7-Segment Display Board 520-5166-00					520-5082-00 Long Hop OPTO	520-5083-01 Long Hop OPTO	L/R Orbit Lane Enter
Viper Night Drivin'	520-5137-01	520-5136-16	520-5138-00	520-5052-00 128 X 32 Dots	520-5055-03	520-5124-00 Single OPTO	520-5125-00 Single OPTO	4-Ball Trough over Up-Kicker	
	Miscellaneous PC Boards:	Relay Board 520-5010-00				520-5082-00 Long Hop OPTO	520-5083-01 Long Hop OPTO	Jump Ramp	
Lost In Space	520-5137-01	520-5136-16	520-5138-00	520-5052-00 128 X 32 Dots	520-5055-03	515-0173-00 Dual OPTO	515-0174-00 Dual OPTO	4-Ball Trough over Up-Kicker	
	Miscellaneous PC Boards:	Relay Board 520-5010-00							
Godzilla	520-5137-01	520-5136-16	520-5138-00	520-5052-00 128 X 32 Dots	520-5055-03	515-0173-00 Dual OPTO	515-0174-00 Dual OPTO	4-Ball Trough over Up-Kicker	
	Miscellaneous PC Boards:	Shaker Mtr. Bd. 520-5065-00							
South Park	520-5137-01	520-5136-16	520-5138-00	520-5052-00 128 X 32 Dots	520-5055-03	515-0173-00 Dual OPTO	515-0174-00 Dual OPTO	5-Ball Trough over Up-Kicker	
	Miscellaneous PC Boards:					520-5082-00 Long Hop OPTO	520-5083-01 Long Hop OPTO	Kenny Under Trough Enter	
Harley-Davidson® 1st-3rd* Editions	520-5137-01	520-5136-16 *520-5300-00*	520-5138-00	520-5052-00 128 X 32 Dots	520-5055-03	515-0173-00 Dual OPTO	515-0174-00 Dual OPTO	4-Ball Trough over Up-Kicker	
	Miscellaneous PC Boards:	Relay Board 520-5010-00		Shaker Mtr. Bd. 520-5065-00	Diode Board 520-5146-00	520-5082-00 Long Hop OPTO	520-5083-01 Long Hop OPTO	Motorcycle Enter	
Striker Xtreme (NFL)	520-5137-01	520-5136-16	520-5138-00	520-5052-00 128 X 32 Dots	520-5055-03	515-0173-00 Dual OPTO	515-0174-00 Dual OPTO	4-Ball Trough over Up-Kicker	520-5155-00 3-Pos. Motor Sensor on Goalie Motor
	Miscellaneous PC Boards:	DC Relay Bd. 520-5066-00	Relay Board 520-5010-00	Diode Board 520-5146-00	for UK ONLY- Solenoid Expander Bd. 520-5192-00	520-5082-00 Long Hop OPTO	520-5083-01 Long Hop OPTO	Goalie Under- Trough Enter	
Sharkey's Shootout	520-5137-64	520-5136-64	520-5138-00	520-5052-00 128 X 32 Dots	520-5055-03	515-0173-00 Dual OPTO	515-0174-00 Dual OPTO	4-Ball Trough over Up-Kicker	520-5194-00 4-Pos. Motor Sensor on ? -Ball Motor
	Miscellaneous PC Boards:	Relay Board 520-5010-00		Sol. Exp. Bd. 520-5192-00					
High Roller Casino	520-5137-01	520-5136-16	520-5138-00	520-5052-00 128 X 32 Dots	520-5055-03	515-0173-00 Dual OPTO	515-0174-00 Dual OPTO	4-Ball Trough over Up-Kicker	520-5194-00 4-Pos. Motor Sensor on Roulette Wheel Motor
	Miscellaneous PC Boards:	Dot Display (5X7) in Slot Mach. 520-5197-00			for UK ONLY- Solenoid Expander Bd. 520-5192-00	520-5196-00 3-Pos. OPTO	520-5195-00 3-Pos. OPTO	Ball Lock under Roulette	Up/Dn Ramp in Slot Mach.
Austin Powers™	520-5137-01	520-5136-16	520-5138-00	520-5052-00 128 X 32 Dots	520-5055-03	515-0173-00 Dual OPTO	515-0174-00 Dual OPTO	4-Ball Trough over Up-Kicker	520-5212-00 Pulse-Stretcher OPTO on Spini-Me
	Miscellaneous PC Boards:	Relay Bd. (X3) 520-5010-00			for UK ONLY- Solenoid Expander Bd. 520-5192-00	520-5082-00 Long Hop OPTO	520-5083-01 Long Hop OPTO	Time Machine Ramp	
MONOPOLY®	520-5137-01	520-5136-16	520-5138-00	520-5052-00 128 X 32 Dots	520-5055-03	515-0173-00 Dual OPTO	515-0174-00 Dual OPTO	4-Ball Trough over Up-Kicker	
	Miscellaneous PC Boards:	DC Relay Bd. 520-5066-00	Mini-Dot Display (3 by 5X7) 520-5197-00 (Electric C- Sign)		for UK ONLY- Solenoid Expander Bd. 520-5192-00	520-5218-00 4-Pos. OPTO	520-5210-00 4-Pos. OPTO	Bank Door	

Table continued on the next page.





# APPENDIX D

## Board Type (White Star Board System\* & S.A.M. System\*\* Only) Table



Game Name	I/O Power Driver	CPU/Sound (old & new)	Disp. Power Supply	Dot Matrix Display	Display Controller	OPTO Transmitter	OPTO Receiver	OPTO Application	Misc OPTO & App.
Playboy	520-5137-01	520-5136-16	520-5138-00	520-5052-00 128 X 32 Dots	520-5055-03	515-0173-00 Dual OPTO	515-0174-00 Dual OPTO	4-Ball Trough over Up-Kicker	
	Miscellaneous PC Boards:	DC Relay Bd. 520-5066-00	Relay Bd. 520-5010-00		for UK ONLY- Solenoid Expander Bd. 520-5192-00				
RollerCoaster Tycoon™	520-5137-01	520-5136-16	520-5138-00	520-5052-00 128 X 32 Dots	520-5055-03	515-0173-00 Dual OPTO	515-0174-00 Dual OPTO	4-Ball Trough over Up-Kicker	520-5222-00 1-Position Switch Detect on Wheel Spin
	Miscellaneous PC Boards:	DC Relay Bd. 520-5066-00	Mini-Dot Display (3 by 5X7) 520-5221-00 (Ramp Enter Sign)		for UK ONLY- Solenoid Expander Bd. 520-5192-00	520-5082-00 Long Hop OPTO	520-5083-01 Long Hop OPTO	Behind 1-Bank Drop Target	
The Simpsons™ Pinball Party	520-5137-01	520-5136-16	520-5138-00	520-5052-00 128 X 32 Dots	520-5055-03	515-0173-00 Dual OPTO	515-0174-00 Dual OPTO	4-Ball Trough over Up-Kicker	
	Miscellaneous PC Boards:	LED Bd. 520-5219-00	Color Dot Display (4 by 5X7) 520-5225-00 (TV Set)		for UK ONLY ◀◀◀ Aux. Driver Bd. 520-5068-01				
Terminator® 3: Rise of the Machines™	520-5137-01	<b>520-5136-16</b>	520-5138-00	520-5052-00 128 X 32 Dots	520-5055-03	515-0173-00 Dual OPTO	515-0174-00 Dual OPTO	4-Ball Trough over Up-Kicker	
	Miscellaneous PC Boards:				for UK ONLY ◀◀◀ Aux. Driver Bd. 520-5068-01	515-7307-00 Single OPTO	515-7308-00 Single OPTO	TXCannon Trough	
The Lord of the Rings™	520-5137-01	<b>New</b> 520-5300-00	520-5138-00	520-5052-00 128 X 32 Dots	520-5055-03	515-0173-00 Dual OPTO	515-0174-00 Dual OPTO	4-Ball Trough over Up-Kicker	500-6746-00 (White Trans.) 500-6747-00 (Black Rec.)
	Miscellaneous PC Boards:	19-LED PCB 520-5242-00	OPTO Transmitter / Receiver Amplifier PCB 520-5239-00		for UK ONLY ◀◀◀ Aux. Driver Bd. 520-5068-01	515-7307-00 Single OPTO	515-7308-00 Single OPTO	Orthanc Tower Trough	
Ripley's Believe It or Not!®	520-5137-01	520-5300-00	520-5138-00	520-5052-00 128 X 32 Dots	520-5055-03	515-0173-00 Dual OPTO	515-0174-00 Dual OPTO	4-Ball Trough over Up-Kicker	500-6775-00 OPTO Trnscvr
	Miscellaneous PC Boards:	520-5236-00 X3 Dot Display	OPTO Transmitter / Receiver Amplifier PCB 520-5239-01		for UK ONLY ◀◀◀ Aux. Driver Bd. 520-5068-01	520-5234-00 3-Pos. OPTO	520-5234-00 3-Pos. OPTO	Vari-Target	520-5235-03 X3 Aux. Drvr
Elvis®	520-5137-01	520-5300-00	520-5138-00	520-5052-00 128 X 32 Dots	520-5055-03	515-0173-00 Dual OPTO	515-0174-00 Dual OPTO	4-Ball Trough over Up-Kicker	
	Miscellaneous PC Boards:				for UK ONLY ◀◀◀ Aux. Driver Bd. 520-5068-01				
The Sopranos™	520-5137-01	520-5300-00	520-5138-00	520-5052-00 128 X 32 Dots	520-5055-03	515-0173-00 Dual OPTO	515-0174-00 Dual OPTO	4-Ball Trough over Up-Kicker	
	Miscellaneous PC Boards:				for UK ONLY ◀◀◀ Aux. Driver Bd. 520-5068-01				
NASCAR® and [INDSE]	520-5137-01	520-5300-00	520-5138-00	520-5052-00 128 X 32 Dots	520-5055-03	515-0173-00 Dual OPTO	515-0174-00 Dual OPTO	4-Ball Trough over Up-Kicker	500-6775-00 OPTO Trans. (Qty. 16) Switch Detect.
	Miscellaneous PC Boards:	520-5235-03 X3 Aux. Drvr	OPTO Transmitter / Receiver Amplifier PCB 520-5239-01		for UK ONLY ◀◀◀ Aux. Driver Bd. 520-5068-01				
Grand Prix	520-5137-01	520-5300-00	520-5138-00	520-5052-00 128 X 32 Dots	520-5055-03	515-0173-00 Dual OPTO	515-0174-00 Dual OPTO	4-Ball Trough over Up-Kicker	500-6775-00 OPTO Trans. (Qty. 16) Switch Detect.
	Miscellaneous PC Boards:	520-5235-03 X3 Aux. Drvr	OPTO Transmitter / Receiver Amplifier PCB 520-5239-01		for UK ONLY ◀◀◀ Aux. Driver Bd. 520-5068-01				

Game Name	I/O Power Driver**	CPU / Sound**	Disp. Power Supply	Dot Matrix Display	Dual OPTO Transmitter	Dual OPTO Receiver	Dual OPTO Transceiver	OPTO Transceiver Miscellaneous
World Poker Tour™ (WPT)	520-5249-00 Backbox	520-5246-00 Backbox	520-5138-00 Backbox	520-5052-00 128 X 32 Dots	515-0173-00 4-Ball Trough	515-0174-00 4-Ball Trough	500-6775-00 4 Switch Pairs (Qty. 8)	520-5251-00 'U' 1/per PCB Jail Bars Up Ace/Hole Mech 520-5252-04 'U' 4/per PCB Drop Targets 4- & 8- Banks
	Miscellaneous PCBs:	520-5254-00 50V Step-Up Drv	520-5250-14 14LED 5X7 Disp.	520-5239-01 OPTO Amplifier	520-5247-00 Ace/Hole Mech	520-5248-00 Ace/Hole Mech		
The Simpsons™ Kooky Carnival	520-5249-00 Back Door	520-5246-00 Back Door	520-5138-00 Cabinet Rear	520-5052-00 128 X 32 Dots			520-5253-00-ASY Coin Drop (Qty. 11)	
	Miscellaneous PCBs:	515-5742-00 Shaker PCB	500-6700-00 Relay (incl. Wiring + Conn.)					
©Disney's Pirates of the Caribbean	520-5249-00 Backbox	520-5246-00 Backbox	520-5138-00 Backbox	520-5052-00 128 X 32 Dots	515-0173-00 4-Ball Trough	515-0174-00 4-Ball Trough	500-6775-00 5 Switch Pairs (Qty. 10)	
	Miscellaneous PCBs:	520-5239-01 OPTO Amp. (X3)	511-5024-03 Relay (incl. Wiring + Conn.)	520-5238-00 : H-E-A-R-T LED PCB				
Family Guy™	520-5249-00 Backbox	520-5246-00 Backbox	520-5138-00 Backbox	520-5052-00 128 X 32 Dots	515-0173-00 4-Ball Trough	515-0174-00 4-Ball Trough	500-6775-00 3 Switch Pairs (Qty. 6)	520-5252-01 'U' 1/per PCB Drop Target 1-Bank
	Miscellaneous PCBs:	520-5239-01 OPTO Amp. (X2)	520-5261-00 Stepper Motor	511-5042-01 Trgt. Sensor (X2)			500-6775-01 1 Switch Pair (Qty. 2)	520-5252-04 'U' 4/per PCB Drop Target 4-Bank
Spider-Man™	520-5249-00 Backbox	520-5246-00 Backbox	520-5138-00 Backbox	520-5052-00 128 X 32 Dots	515-0173-00 4-Ball Trough	515-0174-00 4-Ball Trough	500-6775-00 3 Switch Pairs (Qty. 6)	
	Miscellaneous PCBs:	520-5239-01 OPTO Amp. (X2)						



# APPENDIX D

## Board Type Table

Game Name	Flipper	Sound	Power Supply	Display X-Digit
• Laser War	2-Flipper Board Not Required	<i>initial:</i> 520-5002-00 <i>replaced with:</i> 520-5002-02 <i>520-5002-01 was not used.</i>	520-5000-00	Master: 520-5004-00 plus: 520-5005-00 (Qty. 2); 7 Digit Alpha/Numeric 520-5006-00 (Qty. 2); 7 Digit Numeric 520-5007-00 (Qty. 1); 4 Digit Numeric
• Secret Service • Torpedo Alley	3-Flipper Board Not Required	520-5002-02		520-5014-01 7 Digit Alpha/Numeric Combined
• Time Machine	2-Flipper Board Not Required			520-5030-00 16 Digit Alpha/Numeric Combined
• Playboy 35th Anniversary *	520-5033-00 2-Flipper <i>(*only for 100 games of Playboy 35th Anniv. &amp; ABC Mon. Night Football)</i>			
• ABC Monday Night Football *				
• Robocop				
• Phantom of the Opera • Back to the Future				
• The Simpsons		520-5002-03		

Game Name	Flipper	Sound	Power Supply	Dot Matrix Display	Display Controller	OPTO Transmitter	OPTO Receiver	OPTO Application	
• Checkpoint • Teenage Mutant Ninja Turtles	520-5033-00 2-Flipper	520-5002-03	520-5047-00	520-5042-00 128 X 16	520-5055-00				
• Batman • Star Trek 25th Anniv. • Hook		520-5050-01							
• Lethal Weapon 3		520-5050-02	520-5047-01						
• Star Wars • Rocky & Bullwinkle & Friends			520-5052-00 128 X 32						
• Jurassic Park									
• Last Action Hero	520-5076-00 3-Flipper	520-5050-03	520-5047-02	520-5055-01					
• Tales from the Crypt	520-5076-00 3-Flipper	520-5077-00							
• WWF Royal Rumble	520-5070 / 5080 -00 4-Flipper (2X2)	520-5050-03	520-5047-03	520-5075-00 192 X 64	520-5092-01	520-5102-00 Single OPTO	520-5103-00 Single OPTO	Paddle Boat Wheel Enter	
• Guns N' Roses	520-5076-00 3-Flipper					520-5077-00	520-5124-00 Single OPTO	520-5125-00 Single OPTO	5-Ball Trough over Up-Kicker
• Baywatch	520-5076-00 3-Flipper					520-5126-02	520-5124-00 Single OPTO	520-5125-00 Single OPTO	4-Ball Trough over Up-Kicker
• Batman Forever	520-5076-00 3-Flipper								

Miscellaneous Boards (Lamp Boards & Relay Boards) not listed above can be found in each individual game manual.





# APPENDIX E

## Flipper Coil (White Star Board System\* & S.A.M. System\*\* Only) Table



Typical Coil Diode 1N4004 unless noted otherwise (Diode Top = above lugs next to windings; Diode Below (Bottom) = under lugs opposite of windings).

STANDARD COILS (TYPICAL APPLICATIONS)			LARGE COILS (FLIPPERS & SPECIAL APPLICATIONS)		
Ga.-Turn	Res (Ω)	SPI Part Number and Comments	Ga.-Turn	Res (Ω)	SPI Part Number and Comments
20-400	1.0 Ω	090-5021-use: -00 Diode Top	21-900	call Ω	090-5020-use: -01 3-Lugs + 1N4004 & 1N5404 Diodes -10 Diode Top <BROWN><RED>
22-500	1.7 Ω	090-5017-use: -00 Diode Top	22-750 / 30-2600	2.6 Ω 92.0 Ω	090-5011-use: -00 DUAL WND COIL // 3-Lugs Diode x2
22-600	2.2 Ω	090-5017-use: -0B Diode Below // -0T Diode Top			
23-700	3.1 Ω	090-5022-use: -0B Diode Below // -0T Diode Top	22-900	3.45 Ω	090-5020-use: -20T Diode Top <YELLOW> // -20-ND No Diode
23-750	3.4 Ω	090-5019-use: -00 Diode Top			
23-800	3.6 Ω	090-5001-use: -0B Diode Below // -0T Diode Top // -NL No Lugs 11" Leads // -ND No Diode	22-1080	4.2 Ω	090-5032-use: -0B D. Below // -0T D. Top <YEL-GRN> -NL No Diode
23-840	4.0 Ω	090-5005-use: -00 Diode Top			
23.5-765	3.6 Ω	090-5037-use: -03 Diode Top	23-620 / 30-2600	2.4 Ω 75.0 Ω	090-5006-use: -00 DUAL WND COIL // 3-Lugs Diode x2
24-900	5.0 Ω	090-5002-use: -02 Diode Top // -10 No Lugs 14" Leads			
24-940	5.5 Ω	090-5036-use: -0B Diode Below // -0T Diode Top use 090-5051-01 No Lugs 11" Leads	23-700 / 30-2600	3.0 Ω 83.5 Ω	090-5013-use: -00 DUAL WOUND COIL // Diode Top
25-1240	9.3 Ω	090-5034-use: -00 Diode Below			
26-1200	10.3 Ω	090-5044-use: -0B Diode Below // -0T Diode Top // -NL No Lugs 11" Leads // -ND No Diode	23-800 / 30-2600	2.4 Ω 90.5 Ω	090-5012-use: -00 DUAL WOUND COIL // Diode Top
27-1300	14.2 Ω	090-5003-use: -0T Diode Top			
27-1400	14.7 Ω	090-5015-use: -00 Diode Below	23-1100	5.1 Ω	090-5030-use: -0T Diode Top <ORANGE> -ND No Diode
27-1400	14.7 Ω	511-5031-00 Special App.: No Diode / Lugs + Conn.			
27-1500	16.3 Ω	090-5004-use: -0B Diode Below // -0T Diode Top	23-1200	7.1 Ω	090-5008-use: -00 Diode Top <BLACK>
29-2000	33.6 Ω	090-5016-use: -00 Diode Top			
<b>LARGE, MEDIUM &amp; MINI COILS (MAGNET APPLICATIONS)</b>			23-1500	4.4 Ω	090-5062-use: -00 Diode Top <BLUE>
20.5-480	2.9 Ω	090-5064-use: -02 No Lugs or Core; 14" Leads // Large			
22-650	4.3 Ω	090-5042-use: -00 No Lugs or Core; 6" Leads // Large -01 No Lugs or Core; 12" Leads // Large	24-1570	9.5 Ω	090-5025-use: -00 Diode Top <BLUE>
24-780	8.0 Ω	090-5061-use: -00 No Lugs or Core; 6" Lds. // Medium			
29-1000	15.2 Ω	090-5059-use: -00 Lugs + Diode + Magnet Core // Mini	25-1400	call Ω	090-5067-use: -0T Diode Top <RED>
31-1500	52.0 Ω	090-5054-00: Straight Lugs + Diode + Mag Core // Mini 090-5055-00: 90° Lugs + Diode + Magnet Core // Mini			
<b>MINI COILS (RESET / TRIP APPLICATIONS)</b>			25-1600	call Ω	090-5068-use: -0T Diode Top <WHITE>
27-950	call Ω	090-5046-use: -01 Diode Top			
28-1050	11.5 Ω	090-5046-use: -00 Diode Top	27-880	call Ω	500-6976-01 No Lugs or Diode + 6" Leads & Conn.
27-880	call Ω	500-6976-01 No Lugs or Diode + 6" Leads & Conn.			
31-590	call Ω	090-5010-use: -00 Diode Top	32-1250	35.0 Ω	515-6916-01: includes Flap & Screw <YELLOW>
32-1250	35.0 Ω	515-6916-01: includes Flap & Screw <YELLOW>			
32-1800	50.2 Ω	090-5031-use: -0B Diode Below // -0T Diode Top (515-6110-00) use 515-# to include mounting & armature brackets	33-1590	59.0 Ω	515-6916-00: includes brackets <WHITE>
33-1590	59.0 Ω	515-6916-00: includes brackets <WHITE>			

Please Note: Ohm values may vary +/- .03 depending on meter calibration.  
 Ordering Note: Coils typically should not come with Coil Sleeves. IF A SLEEVE EXISTS, ensure it is the correct sleeve for the application usage. For the correct Coil Sleeve, refer to the Game Assembly Drawing the coil exists on and order separately.



## Flipper Coil (White Star Board System\* Only) Table

GAME NAME	Nº of Flippers	FLIPPERS		FLIPPERS no E.O.S. Switch	
		SPI Nº / GAUGE-TURNS / Color		SPI Nº / GAUGE-TURNS / Color	
		LOWER LEFT	LOWER RIGHT	UPPER LEFT	UPPER RIGHT
Apollo 13	2	090-5032-0T 22-1080 -YEL-GRN-	SAME	Not Used	Not Used
Golden Eye	2	090-5032-0T 22-1080 -YEL-GRN-	SAME	Not Used	Not Used
Twister	2	090-5020-20T 22-900 -YELLOW-	090-5032-0T 22-1080 -YEL-GRN-	Not Used	Not Used
ID4: Independence Day	3	090-5032-0T 22-1080 -YEL-GRN-	SAME	Not Used	090-5020-30 23-900 -GREEN-
Space Jam †	2	090-5032-0T 22-1080 -YEL-GRN-	090-5020-20T 22-900 -YELLOW-	Not Used	Not Used
The Star Wars Trilogy - Special Edition †	2	090-5032-0T 22-1080 -YEL-GRN-	SAME	Not Used	Not Used
The Lost World: Jurassic Park †	2	090-5032-0T 22-1080 -YEL-GRN-	SAME	Not Used	Not Used
The X-Files †	2	090-5032-0T 22-1080 -YEL-GRN-	SAME	Not Used	Not Used
Starship Troopers †	3	090-5030-0T 23-1100 -ORANGE-	SAME	Not Used	090-5032-0T 22-1080 -YEL-GRN-
Viper Night Drivin' †	2	090-5030-0T 23-1100 -ORANGE-	SAME	Not Used	Not Used
Lost In Space †	2	090-5030-0T 23-1100 -ORANGE-	090-5032-0T 22-1080 -YEL-GRN-	Not Used	Not Used
Godzilla †	2	090-5032-0T 22-1080 -YEL-GRN-	SAME	Not Used	Not Used
South Park †	2	090-5030-0T 23-1100 -ORANGE-	SAME	Not Used	Not Used

† Coil Part Numbers ending with a "T" signifies the Diode is on the top of the lug (on the coil-winding side); Coil Part Numbers ending with a "B" signifies the Diode is on the bottom of the lugs.

Table continued on the next page.





# APPENDIX E

## Flipper Coil (White Star Board System\* & S.A.M. System\*\* Only) Table



GAME NAME	N <sup>o</sup> of Flippers	FLIPPERS w/E.O.S. Switch		FLIPPERS no E.O.S. Switch	
		SPI N <sup>o</sup> / GAUGE-TURNS / Color		SPI N <sup>o</sup> / GAUGE-TURNS / Color	
		LOWER LEFT	LOWER RIGHT	UPPER LEFT	UPPER RIGHT
Harley-Davidson® † and 1st through 3rd Editions	2	090-5032-0T <b>22-1080 -YEL-GRN-</b>	090-5030-0T <b>23-1100 -ORANGE-</b>	Not Used	Not Used
Striker Xtreme (NFL) †	3	090-5032-0T <b>22-1080 -YEL-GRN-</b>	090-5030-0T <b>23-1100 -ORANGE-</b>	090-5030-0T <b>23-1100 -ORANGE-</b>	Not Used
Sharkey's Shootout †	3	090-5030-0T <b>23-1100 -ORANGE-</b>	SAME	090-5030-0T <b>23-1100 -ORANGE-</b>	Not Used
High Roller Casino †	2	090-5032-20T <b>22-900 -YELLOW-</b>	090-5032-0T <b>22-1080 -YEL-GRN-</b>	Not Used	Not Used
Austin Powers™ †	2	090-5020-30 <b>23-900 -GREEN-</b>	090-5030-0T <b>23-1100 -ORANGE-</b>	Not Used	Not Used
MONOPOLY® †	3	090-5032-0T <b>22-1080 -YEL-GRN-</b>	SAME	Not Used	090-5062-0T <b>23-1500 -BLUE-</b>
Playboy †	2	090-5030-0T <b>23-1100 -ORANGE-</b>	SAME	Not Used	Not Used
RollerCoaster Tycoon™ †	4	090-5032-0T <b>22-1080 -YEL-GRN-</b>	SAME	090-5067-0T <b>25-1400 -RED-</b>	090-5068-0T <b>25-1600 -WHITE-</b>
The Simpsons™ Pinball Party †	6** (5 with Flipper Bats)	090-5032-0T <b>22-1080 -YEL-GRN-</b>	SAME	Not Used	090-5030-0T <b>23-1100 -ORANGE-</b>
		** The Homer Head Assembly is affixed to an Upr. Rt. Style Flipper (no E.O.S. Switch):		Flippers (Mini-Bats) on 2nd Level Playfield:	
			** 090-5020-20T <b>22-900 -YELLOW-</b>	090-5041-00T <b>25-1800 -BLU-GRN-</b>	090-5025-00 <b>24-1570 -BLUE-</b>
Terminator® 3: Rise of the Machines™ †	2	090-5032-0T <b>22-1080 -YEL-GRN-</b>	SAME	Not Used	Not Used
The Lord of the Rings™ †	2	090-5020-20T <b>22-900 -YELLOW-</b>	SAME	Not Used	Not Used
Ripley's Believe It or Not!® †	3	090-5032-0T <b>22-1080 -YEL-GRN-</b>	SAME	Not Used	090-5067-00T <b>25-1400 -RED-</b>
Elvis® †	4	090-5020-20T <b>22-900 -YELLOW-</b>	SAME	090-5020-30 <b>23-900 -GREEN-</b>	SAME
The Sopranos™ †	2	090-5032-0T <b>22-1080 -YEL-GRN-</b>	SAME	Not Used	Not Used
NASCAR® and [NDSE] †	2	090-5030-0T <b>23-1100 -ORANGE-</b>	SAME	Not Used	Not Used
Grand Prix †	2	090-5030-0T <b>23-1100 -ORANGE-</b>	SAME	Not Used	Not Used
† Coil Part Numbers ending with a "T" signifies the Diode is on the top of the lug (on the coil-winding side); Coil Part Numbers ending with a "B" signifies the Diode is on the bottom of the lugs.					
** S.A.M. System Games DO NOT REQUIRE DIODES. If you use a coil from your stock which has a diode, remove it ONLY FOR S.A.M. System Games.					
World Poker Tour™ (WPT)**	4	090-5032-ND <b>22-1080 [ NO DIODE ]</b>	SAME	090-5030-ND <b>23-1100 [ NO DIODE ]</b>	SAME
©Disney's Pirates of the Caribbean**	2	090-5030-ND <b>23-1100 [ NO DIODE ]</b>	SAME	Not Used	Not Used
Family Guy™ **	3 Norm.	090-5030-ND <b>23-1100 [ NO DIODE ]</b>	SAME	090-5062-ND <b>23-1500 [ NO DIODE ]</b>	Not Used
	2 Mini	090-5046-01-ND <b>27-950 [ NO DIODE ]</b>	SAME		
Spider-Man™ **	3	090-5032-ND <b>22-1080 [ NO DIODE ]</b>	SAME	Not Used	090-5032-ND <b>22-1080 [ NO DIODE ]</b>



# APPENDIX E

## Generic Coil Cross-Reference Guide † ‡

### Flipper Coil Table ‡ ††

GAME NAME	Nº of Flippers	FLIPPERS w/E.O.S. Switch		FLIPPERS no E.O.S. Switch	
		SPI Nº / GAUGE-TURNS / Color		SPI Nº / GAUGE-TURNS / Color	
		LOWER LEFT	LOWER RIGHT	UPPER LEFT	UPPER RIGHT
Laser War ‡	2	090-5011-00 22-750 / 30-2600	SAME	Not Used	Not Used
Secret Service ‡	3	090-5006-00 23-620 / 30-2600	SAME	Not Used	090-5006-00 23-620 / 30-2600
Torpedo Alley ‡	3	090-5011-00 22-750 / 30-2600	090-5013-00 23-700 / 30-2600	Not Used	090-5012-00 23-800 / 30-2600
Time Machine ‡	2	090-5011-00 22-750 / 30-2600	SAME	Not Used	Not Used
‡ These coils are dual-wound.					
Playboy 35th Anniversary ††	2	090-5020-02 22-900 -YEL-YEL-	SAME	Not Used	Not Used
ABC Monday Night Football ††	2	090-5020-02 22-900 -YEL-YEL-	SAME	Not Used	Not Used
†† A very small % of these games used a 090-5020-20 coil which used a proto-type Solid State Flipper System. The two types of coils both are 22-900 coils; the only difference is the addition of the 1N5404 Diode on the (-02) coils which was used in the Deger Design.					
Robocop	2	090-5020-20 22-900 -YEL-YEL-	SAME	Not Used	Not Used
Phantom of the Opera	2	090-5020-20 22-900 -YEL-YEL-	SAME	Not Used	Not Used
Back to the Future	2	090-5020-20 22-900 -YEL-YEL-	SAME	Not Used	Not Used
The Simpsons	2	090-5020-20 22-900 -YEL-YEL-	SAME	Not Used	Not Used
Checkpoint	2	090-5020-20 22-900 -YEL-YEL-	SAME	Not Used	Not Used
Teenage Mutant Ninja Turtles	2	090-5020-30 23-900 -GRN-GRN-	SAME	Not Used	Not Used
Batman	2	090-5020-30 23-900 -GRN-GRN-	SAME	Not Used	Not Used
Star Trek 25th Anniversary	2	090-5020-30 23-900 -GRN-GRN-	SAME	Not Used	Not Used
Hook	2	090-5030-00 23-1100 -ORG-ORG-	090-5020-30 23-900 -GRN-GRN-	Not Used	Not Used
Lethal Weapon 3	2	090-5030-00 23-1100 -ORG-ORG-	SAME	Not Used	Not Used
Star Wars	2	090-5032-00 22-1080 -YEL-GRN-	SAME	Not Used	Not Used
Rocky & Bullwinkle & Friends	2	090-5020-30 23-900 -GRN-GRN-	SAME	Not Used	Not Used
Jurassic Park	3	090-5020-30 23-900 -GRN-GRN-	SAME	Not Used	090-5030-00 23-1100 -ORG-ORG-

*Table continued on the next page.*



## APPENDIX E

### Flipper Coil Table †

GAME NAME	N <sup>o</sup> of Flippers	FLIPPERS w/ E.O.S. Switch		FLIPPERS no E.O.S. Switch	
		SPI N <sup>o</sup> / GAUGE-TURNS / Color		SPI N <sup>o</sup> / GAUGE-TURNS / Color	
		LOWER LEFT	LOWER RIGHT	UPPER LEFT	UPPER RIGHT
Last Action Hero	2	090-5020-30 23-900 -GRN-GRN-	SAME	Not Used	Not Used
Tales from the Crypt	3	090-5032-00 22-1080 -YEL-GRN-	SAME	Not Used	090-5041-00 25-1800 -BLU-GRN-
The Who's Tommy	3	090-5020-30 23-900 -GRN-GRN-	SAME	090-5041-00 25-1800 -BLU-GRN-	Not Used
WWF Royal Rumble	4	090-5032-00 22-1080 -YEL-GRN-	SAME	090-5041-00 25-1800 -BLU-GRN-	SAME
Guns N' Roses	3	090-5032-00 22-1080 -YEL-GRN-	SAME	090-5030-00 23-1100 -ORG-ORG-	Not Used
Maverick	3	090-5032-00 22-1080 -YEL-GRN-	SAME	Not Used	090-5032-00 22-1080 -YEL-GRN-
Mary Shelley's Frankenstein	3	090-5030-00 23-1100 -ORG-ORG-	SAME	Not Used	090-5030-00 23-1100 -ORG-ORG-
Baywatch	4	090-5030-00 23-1100 -ORG-ORG-	090-5020-30 23-900 -GRN-GRN-	090-5025-00 24-1570 -See Note-	090-5030-00 23-1100 -ORG-ORG-
Batman Forever	3	090-5032-00 22-1080 -YEL-GRN-	090-5020-20 22-900 -YEL-YEL-	Not Used	090-5020-30 23-900 -GRN-GRN-
Apollo 13	2	090-5032-00 22-1080 -YEL-GRN-	SAME	Not Used	Not Used
Golden Eye	2	090-5032-00 22-1080 -YEL-GRN-	SAME	Not Used	Not Used
Twister	2	090-5020-20 22-900 -YEL-YEL-	090-5032-00 22-1080 -YEL-GRN-	Not Used	Not Used
ID4: Independence Day	3	090-5032-00 22-1080 -YEL-GRN-	SAME	Not Used	090-5020-30 23-900 -GRN-GRN-
Space Jam †	2	090-5032-00T 22-1080 -YEL-GRN-	090-5020-20T 22-900 -YEL-YEL-	Not Used	Not Used
The Star Wars Trilogy - Special Edition †	2	090-5032-00T 22-1080 -YEL-GRN-	SAME	Not Used	Not Used
The Lost World: Jurassic Park †	2	090-5032-00T 22-1080 -YEL-GRN-	SAME	Not Used	Not Used
The X-Files †	2	090-5032-00T 22-1080 -YEL-GRN-	SAME	Not Used	Not Used
Starship Troopers †	3	090-5030-00T 23-1100 -ORG-ORG-	SAME	Not Used	090-5032-00T 22-1080 -YEL-GRN-
Viper Night Drivin' †	2	090-5030-00T 23-1100 -ORG-ORG-	SAME	Not Used	Not Used
Lost In Space †	2	090-5030-00T 23-1100 -ORG-ORG-	090-5032-00T 22-1080 -YEL-GRN-	Not Used	Not Used
Godzilla †	2	090-5032-00T 22-1080 -YEL-GRN-	SAME	Not Used	Not Used
South Park †	2	090-5030-00T 23-1100 -ORG-ORG-	SAME	Not Used	Not Used
Harley-Davidson® † and Harley-Davidson® 2nd Ed. †	2	090-5032-00T 22-1080 -YEL-GRN-	090-5030-00T 23-1100 -ORG-ORG-	Not Used	Not Used
Striker Xtreme (NFL) †	3	090-5032-00T 22-1080 -YEL-GRN-	090-5030-00T 23-1100 -ORG-ORG-	090-5030-00T 23-1100 -ORG-ORG-	Not Used
Sharkey's Shootout †	3	090-5030-00T 23-1100 -ORG-ORG-	SAME	090-5030-00T 23-1100 -ORG-ORG-	Not Used
High Roller Casino †	2	090-5020-20T 22-900 -YEL-YEL-	090-5032-00T 23-1080 -YEL-GRN-	Not Used	Not Used
Austin Powers™ †	2	090-5020-30 23-900 -GRN-GRN-	090-5030-00T 23-1100 -ORG-ORG-	Not Used	Not Used
MONOPOLY® †	3	090-5032-00T 22-1080 -YEL-GRN-	SAME	Not Used	090-5062-00T 23-1500 -BLU-BLU-
Playboy †	2	090-5030-00T 23-1100 -ORG-ORG-	SAME	Not Used	Not Used
RollerCoaster Tycoon™ †	4	090-5032-00T 22-1080 -YEL-GRN-	SAME	090-5067-00T 25-1400 -RED-RED-	090-5068-00T 25-1600 -WHT-WHT
The Simpsons™ Pinball Party †	6* (5 with Flipper Bats)	090-5032-00T 22-1080 -YEL-GRN-	SAME	Not Used	090-5030-00T 23-1100 -ORG-ORG-
		* The Homer Head Assembly is affixed to an Upr. Rt. Style Flipper (no E.O.S. Switch):		Flippers (Mini-Bats) on 2nd Level Playfield:	
			* 090-5020-20T 22-900 -YEL-YEL-	090-5041-00T 25-1800 -BLU-GRN-	090-5025-00T 24-1570 -See Note-
Terminator® 3: Rise of the Machines™ †	2	090-5032-00T 22-1080 -YEL-GRN-	SAME	Not Used	Not Used
The Lord of the Rings™ †	2	090-5020-20T 22-900 -YEL-YEL-	SAME	Not Used	Not Used
Ripley's Believe It or Not!® †	3	090-5032-00T 22-1080 -YEL-GRN-	SAME	Not Used	090-5067-00T 25-1400 -RED-RED-

† Coil Part N<sup>o</sup>s ending with a "T" signifies the Diode is on the top of the lug (on the coil-winding side); Coil Part N<sup>o</sup>s ending with a "B" signifies the Diode is on the bottom of the lugs.



# APPENDIX F

## Motor Specification (White Star Board System\* Only) Table



Game Name	Function	Specifications	Part Number
Apollo 13	Rocket Up/Down Movement	Bowman Motor 24VAC 60Hz 3W 6 RPM CCW	515-6383-00 <i>incl. Connector</i>
	Moon Unit Rotational Orbit	Multi Products Motor 24VAC 50/60Hz 3W 6 RPM CCW	515-6487-00 <i>incl. Connector</i>
	Shaker	Johnson Motor (Vibrator) 10.5VDC 10 AMP 2950 RPM CW	041-5029-00 <b>MOTOR ONLY</b>
Golden Eye	Satellite Left/Right Movement	Bowman Motor 24VAC 60Hz 3W 6 RPM CW	515-6528-00 <i>incl. Connector</i>
Twister	Spinning Disc with Magnet	Multi Products Motor 24VAC (041-5026-00) 50/60Hz 3W 325 RPM CCW	515-6347-00 <i>incl. Connector</i>
	Backbox Fan (Tornado Wind)	Multi Products Motor 24VAC (041-5052-00) 50/60Hz 3W 3600 RPM CW	515-6531-00 <i>incl. Connector</i>
ID4: Independence Day	Alien Head Open/Close Movement	Servo Motor (94322)	041-5045-00 <b>MOTOR ONLY</b>
<i>SPACE JAM (NO MOTOR USED)</i>			
The Star Wars Trilogy - S.E.	X-Wing Left/Right Movement	Bowman Motor 24VAC (041-5058-00) 60Hz 3W 10 RPM CCW	515-6383-01 <i>incl. Connector</i>
The Lost World: Jurassic Park	Snagger & Center Link Lift Up/Down Movement	Multi Products Motor 20VDC (041-5059-03) 9 RPM Non-Directional	515-6715-03 <i>incl. Connector</i>
	Shaker	Johnson Motor (Vibrator) 10.5VDC 10 AMP 2950 RPM CW	041-5029-00 <b>MOTOR ONLY</b>
The X-Files	X-File Cabinet Lift Up/Down Movement	Multi Products Motor 20VDC 9 RPM CCW	041-5057-00 <b>MOTOR ONLY</b>
Starship Troopers	Warrior Bug Forward/Reverse Movement	Haydon Switch & Instrument, Inc. Stepper Motor 12VDC 4.6W (041-5062-00), Series 36000: 1.4"ø (Non-Captive Shaft <b>not included</b> ) HSI #36864-12 (Unipolar) Travel per Step: .004 Step Angle: 15°	515-6794-00 <i>incl. Connector</i> Requires 7" Shaft: 530-5503-00
<i>VIPER NIGHT DRIVIN' (NO MOTOR USED)</i>			
Lost In Space	Spinning Disc with Magnet	Multi Products Motor 24VAC (041-5046-00) 50/60Hz 3W 325 RPM CCW	515-6347-00 <i>incl. Connector</i>
Godzilla	Shaker ‡	Multi #3811 0630 Motor (Vibrator) 12VDC 3100 RPM CW (w/DRL PTS) ‡	041-5029-01 <b>MOTOR ONLY</b>
<i>SOUTH PARK (NO MOTOR USED)</i>			
Harley-Davidson® 1st through 3rd Editions	Shaker ‡	Multi #3811 0630 Motor (Vibrator) 12VDC 3100 RPM CW (w/DRL PTS) ‡	041-5029-01 <b>MOTOR ONLY</b>
	Motorcycle Lift Up/Down Movement	Autotrol 24VAC (041-5072-02) 20 RPM CCW	515-7025-00 <i>incl. Connector</i>
Striker Xtreme (NFL)	Goalie (Linebacker) Left to Right Movement	Multi #3590 12VDC (041-5075-00) 60 RPM	515-7071-00 <i>incl. Connector</i>
Sharkey's Shootout	Mystery Ball Rotating Movement	Hankscraft Motor Model-E 24VAC (041-5076-00) 50/60Hz 3W 20 RPM CW	515-7095-00 <i>incl. Connector</i>
High Roller Casino	Roulette Wheel Rotating Movement	Multi Products Motor 20VDC (041-5078-00) 17 RPM CCW	515-7153-00 <i>incl. Connector</i>
	Up/Dn. Ramp in Slot Mach. Lift Up/Down Movement	Haydon Switch & Instrument, Inc. Stepper Motor 12VDC 4.6W (041-5062-00), Series 36000: 1.4"ø (Non-Captive Shaft <b>not included</b> ) HSI #36864-12 (Unipolar) Travel per Step: .004 Step Angle: 15°	515-6794-00 <i>incl. Connector</i> Requires Shaft 4¼": 530-5503-01
Austin Powers™	Time Machine Rotating Movement	Multi Products Motor 24VAC (041-5079-00) 50/60Hz 20RPM CCW	515-7141-00 <i>incl. Connector</i>
	Laser Beam Left to Right Directional	Autotrol Motor 24VAC (041-5081-00) 50/60Hz 4W 10RPM Bi-Directional	515-7171-00 <i>incl. Connector</i>
	Dr. Evil Target Lift Up/Down Movement	Hankscraft Motor Model-E 24VAC (041-5030-00) 50/60Hz 6RPM CCW	515-5900-00 <i>incl. Connector</i>
Monopoly®	Mini-Flipper (Waterworks) Rotating Movement	Multi Prod. Motor & Gear Box #7000 EX00159A 20VDC 50/60Hz 85RPM CC/CCW	041-5083-00 <b>MOTOR ONLY</b>
Playboy	Triangular Billboard Rotating Movement	Autotrol Motor (BD511 150-1387) 24VAC 50/60Hz 12RPM Bi-Directional	041-5086-02 <b>MOTOR ONLY</b>
	Centerfold Mechanism Open/Close Movement	Multi Products (3680) Motor 12v DC 10/12 RPM CC/CCW	041-5075-04 <b>MOTOR ONLY</b>
	Tease Drop Screen Lift Up/Down Movement	Haydon Switch & Instrument, Inc. Stepper Motor 12VDC 4.6W (041-5062-00), Series 36000: 1.4"ø (Non-Captive Shaft <b>not included</b> ) HSI #36864-12 (Unipolar) Travel per Step: .004 Step Angle: 15°	515-6794-00 <i>incl. Connector</i> Requires 7" Shaft: 530-5503-00

‡ Please Note: ".01" Shaker Motor is **Not Compatible** with old Shaker Motor 041-5029-00 (Shaker Motor Assy. 515-5893-00). THIS NEW MOTOR CAN ONLY BE USED IN NEW SHAKER MOTOR ASSY. 515-5893-01.

Table continued on the next page.







# APPENDIX F

## Motor Specification (White Star Board System\* & S.A.M. System\*\* Only) Table



Game Name	Function	Specifications	Part Number
<b>ROLLERCOASTER TYCOON™ (NO MOTOR USED)</b>			
<b>THE SIMPSONS™ PINBALL PARTY (NO MOTOR USED)</b>			
<b>Terminator® 3: Rise of the Machines™</b>	Backbox Ball Shooter Up/Down Movement	Multi Products Motor 24VAC (041-5079-01) 21 RPM CW	515-7317-00 <i>incl. Connector</i>
<b>The Lord of the Rings™</b>	Balrog (Motor & Gate) Open/Close Movement	Multi Prod. Motor 20VDC Series 600B (or equiv.) 50/60Hz 10 RPM Bi-Directional	041-5088-01 <b>MOTOR ONLY</b>
<b>RIPLEY'S BELIEVE IT OR NOT!® (NO MOTOR USED)</b>			
<b>Elvis®</b>	Elvis™ Front/Back Movement	Haydon Switch & Instrument, Inc. Stepper Motor 12VDC 10W (041-5089-00), (Non-Captive Shaft <b>not included</b> ) HSI #46868-12-002	500-6809-00 <i>incl. Connector</i> Requires 7.25" Shaft: 530-5658-00
	▶▶▶ <b>OPTIONAL</b> ◀◀◀ Shaker	Multi #3811 0630 Motor (Vibrator) 12VDC (041-5029-01) 3100 RPM (w/DRL PTS)	515-5893-01 <i>incl. Connector</i>
<b>The Sopranos™</b>	Bada Bing! Girls x2 Rotating Posts Movement	Autotrol Synchronous Motor 24VAC 4W 50/60Hz 45.7/54.9 RPM Bi-Directional	041-5092-00 <i>w/1" Shaft + 12" Leads</i>
<b>NASCAR® and [NDSE]</b>	Back Panel Rotating (Car) Windmill (Skill Ball Enter)	Multi Products Motor & Gear Box 20VDC Model #8000 (EX-04-073) 10 RPM	041-5093-00 <b>MOTOR ONLY</b>
<b>Grand Prix</b>	Back Panel Rotating (Car) Windmill (Skill Ball Enter)	Multi Products Motor & Gear Box 20VDC Model #8000 (EX-04-073) 10 RPM	041-5093-00 <b>MOTOR ONLY</b>
<b>World Poker Tour™ (WPT) (NO MOTOR USED)</b>			
<b>The Simpsons™ Kooky Carnival</b>	Bart on Skateboard Left/Right Movement	Multi Products Motor with Crank 24VAC (041-5095-01) 50/60Hz 3W 14 RPM	500-6947-01 <i>incl. Connector</i>
	Left & Right Ramps Up/Down Movement	Multi Products Motor 24VAC (041-5048-01) 50/60Hz 3W 15 RPM CCW (Qty. 2 in game)	515-7558-00 <i>incl. Connector</i>
	Shaker <i>(details in SKC Manual, Page 24)</i>	Multi #3811 0630 Motor (Vibrator) 12VDC 3100 RPM (w/DRL PTS)	041-5029-01 <b>MOTOR ONLY</b>
<b>©Disney's Pirates of the Caribbean</b>	Spinning Disk	Multi #3811R 0630 Motor (Vibrator) 12VDC (041-5029-04) 3100 RPM (w/DRL PTS) -04 is RoHS compliant; can substitute with -01 domestic	511-5024-04 <i>incl. Connector</i>
	Pirate Ship Sinking/Raising Movement	Multi Products Motor & Gear Box 24VDC Model #7000-DCM 12 RPM	041-5101-00 <b>MOTOR ONLY</b>
<b>Family Guy™</b>	Stewie Figurine Left & Right Movement	Stepper Motor NPM PF35T-48D4STD 5V RVB (041-5102-00 Reference Only)	511-5043-00 <i>incl. Connector</i>
<b>Spider-Man™</b>	Doc Ock, Sandman & 3-Bank Up/Down Movement	Sync. Motor 24VAC 50/60Hz 3W 12 RPM CW (041-5103-00 Reference Only)	511-5063-00 <i>incl. Connector</i>
	▶▶▶ <b>OPTIONAL</b> ◀◀◀ Shaker Motor Kit 502-5027-00	Multi #3811R 0630 Motor (Vibrator) 12VDC (041-5029-04) 3100 RPM (w/DRL PTS) -04 is RoHS compliant; can substitute with -01 domestic	515-5893-01 <i>incl. Connector</i>



## APPENDIX F

### Motor Specification Table

The following table only list games that used motors. Part Numbers starting with "515-" will include the Wiring Harness & Connector.

Game Name	Function	Specifications	Part N <sup>o</sup>
<b>ABC Monday Night Football</b>	Goal Post Up/Down Movement	Motor 24v A.C. 60 RPM CW	515-5222-00
<b>Phantom of the Opera</b>	Organ Up/Down Movement	Bowman Motor 24v 60Hz 3W 11 RPM CCW	515-5256-00
<b>Checkpoint</b>	Mag Wheel (in Backbox)	Motor D.C. (KEN)	041-5005-00
	Shaker	Johnson Motor (Vibrator)	041-5002-00
<b>Teenage Mutant Ninja Turtles</b>	Spinning Pizza Ball Deflector	Gear Motor 24v A.C. 325 RPM CW	515-5397-00
<b>Batman</b>	Bar Target Up/Down Movement	Bowman Motor 24v 60Hz 3W 11 RPM CCW	515-5256-00
<b>Star Trek 25th Anniversary</b>	Swinging Target	Bowman Motor 24v 22½ RPM	515-5534-00
	Transporter F/X	Gear Motor 24v A.C. 3½ RPM	500-5421-00
	Cooling Fan (for Transporter F/X)	4½" Motor 12v	041-5014-00
<b>Lethal Weapon 3</b>	Spinning Light	Motor 2½ v A.C. 4000 RPM CCW	041-5017-00
<b>Star Wars</b>	Bar Target Up/Down Movement	Bowman Motor 24v 60hz 3W 11 RPM CCW	515-5256-00
	R2D2 Robot Left/Right Movement	Bowman Motor 24v A.C. 22½ RPM CW	515-5571-00
	Death Star Rotation	Bowman "G" Motor 24v A.C. 60Hz 6 RPM CW	515-5570-00
<b>Rocky &amp; Bullwinkle &amp; Friends</b>	Nell Log "Cutting Blade" Forward/Back Movement	Autotrol Model E Motor 24v 60hz 4W 3 RPM CCW	041-5023-00
<b>Jurassic Park</b>	T-Rex Left/Right Movement	Multi Motor 5v D.C.	041-5025-00
	T-Rex Up/Down Movement	Bowman Motor 24v 11 RPM CW	041-5026-00
	Shaker	Johnson Motor (Vibrator)	041-5002-00
<b>Last Action Hero</b>	Crane Left/Right Movement	Multi Products Motor 12v D.C. #3312 OSC	041-5027-00
	Shaker	Johnson Motor (Vibrator) 10.5v D.C. 10 AMP 2950 RPM CW	041-5029-00
<b>Tales from the Crypt</b>	Tombstone Up/Down Movement	Bowman Motor 24v A.C. 6 RPM CCW	515-5900-00
	Shaker	Johnson Motor (Vibrator) 10.5v D.C. 10 AMP 2950 RPM CW	041-5029-00
<b>The Who's Tommy</b>	Mirror Up/Down Movement	Bowman Motor 24v A.C. 6 RPM CCW	515-5900-00
	Flipper Blinders	Servo Motor (94102)	041-5032-00
	Spinning Airplane Propellers	Motor D.C.	041-5033-00
<b>WWF Royal Rumble</b>	Shaker	Johnson Motor (Vibrator) 10.5v D.C. 10 AMP 2950 RPM CW	041-5029-00
<b>Maverick, The Movie</b>	Turning Paddle Wheel	Motor 24v A.C. 10 RPM	041-5036-00
<b>Mary Shelley's Frankenstein</b>	Creature Head Left/Right Movement	Servo Motor (94102)	041-5032-00
<b>Batman Forever</b>	Cannon Left/Right Movement	Bowman Motor 24v A.C. 60Hz 3W 6 RPM CCW	515-6383-00

# APPENDIX G

## Part Number Prefix Classification Codes

### I. Electrical Source, Energy & Signal Converters

- 010- Transformers
- 031- Speakers
- 090- Solenoids (Coils)
- 150- Filters, Outlets, Varistors, Thermistors
- 200- Fuses

### II. Conductors, Connectors & Insulators

- 034- Line Cords
- 036- Cable Assemblies & Wiring Harnesses
- 041- Motors
- 045- Connectors (All Types)
- 055- Lugs (M/F), Pins (M/F), Discs, Ring Terminals, Terminal Strips, etc.
- 060- Polarizing Keys and Conn. Covers
- 077- Lamp Sockets

### III. Circuits & Circuit Elements

- 100- ICs
- 110- Transistors
- 112- Diodes (All Types including LEDs & Modules)
- 121- Resistors
- 123- Resistors (Variable & Adjustable)
- 124- Regulators & Bridge Rectifiers
- 125- Capacitors (Radial Lytics & Ferrites)
- 126- Piezo Crystal
- 127- Heatsinks
- 130- Capacitors (Tectates & Ceramics)
- 140- Oscillators (Clocks/Crystals)
- 165- Light Bulbs
- 180- Switches
- 181- Switch Membranes (Pads) & Piezo Sensors
- 190- Relays
- 960- EPROM (*Raw Part*)
- 965- EPROM (*Programmed Part*)

### IV. Bolts, Screws, Nuts, Washers & Nails

- 231- Bolts
- 232- Screws (Pan Head)
- 234- Screws (HWH)
- 237- Screws (Misc.)
- 240- Nuts (Misc.)
- 242- Washers (Flat, Round)
- 244- Washers (Split Lock)
- 245- Nyloners
- 246- Washers (Lockers, External Tooth)
- 281- Nails

### V. Mechanical Components

- 249- Rivets
- 251- Pins (Dowel), Finishing Nails, Hairpins, Spring Pins and Clevis Pins
- 254- Stand-Offs, Spacers and Shims
- 260- Steel Ball (All Types Steel, Glowing, Delrin, etc.)
- 265- Springs (Extension)
- 266- Springs (Compression)
- 267- Springs (Torsion)
- 269- Springs (Washers - Belleville, Wave)
- 270- Retaining Rings
- 280- Grommets, Bushings and Nyloners
- 283- Bearings

### VI. Handles, Locks, Catches, Latches, Keys

- 355- Handles, Locks, Catches, Latches and Keys

### VII. Fabricated Parts

- 390- Hinges
- 501- Coin Doors
- 515- Sub-Assemblies
- 520- Printed Circuit Boards (PCBs)
- 522- Display Glass
- 525- Wood Parts
- 530- Screw Machined Parts
- 535- Fabricated Parts
- 545- Molded (Extruded) Plastic and Rubber Parts (Rings, Sleeves, etc.)
- 550- Molded (Inserts)

### VIII. In-House Assemblies

- 500- End Product (Systems and Models)
- 502- Kits (Created In-House)
- 505- Cabinets (complete)
- 510- Riveted Sub-Assemblies (In-House)
- 511- Sub-Assemblies (In-House)
- 515- Sub-Assemblies\*

\*2 or more 515-'s but still a sub-assembly.

### IX. Bulk Materials

- 600- Braided Wire & Ground Straps
- 601- Stranded Wire
- 602- Ribbon Cable
- 604- Telephone Line Cord
- 605- Sleeving (Shrink Tubing)
- 625- Velcro (non-adhesive)
- 626- Foam Rubber, Foam Pads, Rubber Bumpers (Blue Pads), Tape (All Types) Velcro (adhesive) and String / Rope













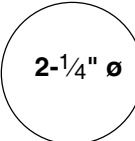
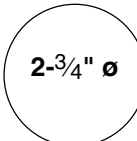
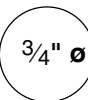
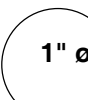
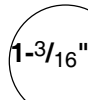
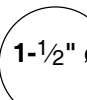
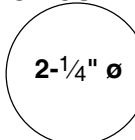
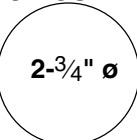

### X. Miscellaneous

- 000- Tools (*see also 777-*) and Supplies
- 040- Clamps, Ties & Clips
- 042- Pulleys
- 091- Coin Mechs
- 205- Fuse Holders
- 631- Staples
- 660- Glass (Playfield, Backglass, etc.)
- 675- Cleaners
- 705- Packing & Shipping Items
- 755- Instruction, Coin Cards, Ins. Sheets
- 756- Information Sheets, Service Bulletins, Instruction Sheets in Kits and Templates
- 777- Tools (Wrenches and Drivers)
- 780- Manuals
- 802- Decal Kits (comprised of 820's)
- 820- Decals, Mylar and Labels (Sheets/Sets)
- 803- Plastic Kits (comprised of 830's)
- 830- Plastic Pieces (Butyrate Sheets/Sets)
- 880- Toys, Models, Figurines, etc.
- 900- Game Posters

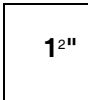
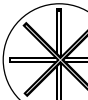
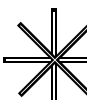
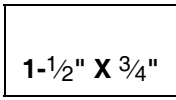
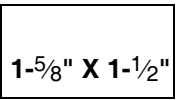
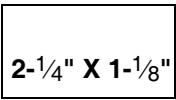
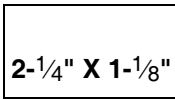
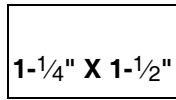
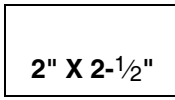

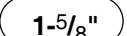
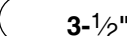
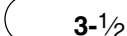
# APPENDIX H

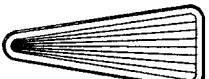
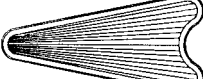
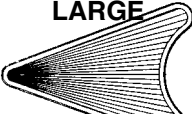
## Playfield Inserts (Plastic Light Covers)

<b>Patterns:</b> <b>STARBURST</b>  <b>STIPPLE</b> 	<b>STARBURST CIRCULAR</b>  <b>550-5000-XX</b>	<b>STARBURST CIRCULAR</b>  <b>550-5001-XX</b>	<b>STARBURST CIRCULAR</b>  <b>550-5002-XX</b>	<b>STARBURST CIRCULAR</b>  <b>550-5003-XX</b>	<b>STARBURST CIRCULAR</b>  <b>550-5004-XX</b>
<b>STARBURST CIRCULAR</b>  <b>550-5005-XX</b>	<b>STARBURST CIRCULAR</b>  <b>550-5006-XX</b>	<b>PLAIN CIRCULAR</b>  <b>550-5007-XX</b>	<b>PLAIN CIRCULAR</b>  <b>550-5008-XX</b>	<b>PLAIN CIRCULAR</b>  <b>550-5009-XX</b>	<b>PLAIN CIRCULAR</b>  <b>550-5010-XX</b>
<b>PLAIN CIRCULAR</b>  <b>550-5011-XX</b>	<b>PLAIN CIRCULAR</b>  <b>550-5012-XX</b>	<b>STIPPLE CIRCULAR</b>  <b>550-5048-XX</b>	<b>STIPPLE 1" SQUARE</b>  <b>550-5019-XX</b>	<b>ROLLOVER BUTTON BASE</b>  <b>550-5026-XX</b>	<b>WHITE STAR (only in white)</b>  <b>545-5015-00</b>
<b>STIPPLE RECTANGULAR</b>  <b>550-5018-XX</b>	<b>STIPPLE RECTANGULAR</b>  <b>550-5051-XX</b>	<b>STARBURST RECTANGULAR</b>  <b>550-5044-XX</b>	<b>PLAIN RECTANGULAR</b>  <b>550-5049-XX</b>	<b>PLAIN RECTANGULAR</b>  <b>550-5050-XX</b>	<b>PLAIN RECTANGULAR</b>  <b>550-5063-XX</b>
<b>STARBURST MINI SHIELD</b>  <b>550-5024-XX</b>	<b>STARBURST LARGE SHIELD</b>  <b>550-5025-XX</b>	<b>MINI HOT DOG</b>  <b>550-5020-XX</b>	<b>BEVEL HOT DOG</b>  <b>550-5021-XX</b>	<b>PLAIN HOT DOG</b>  <b>550-5022-XX</b>	<b>BANANA</b>  <b>550-5023-XX</b>
<b>STARBURST ARROW-SMALL</b>  <b>550-5013-XX</b>	<b>STARBURST ARROW-LARGE</b>  <b>550-5070-XX</b>	<b>STARBURST ARROW-HEAD SMALL</b>  <b>550-5014-XX</b>	<b>STARBURST ARROW-HEAD LARGE</b>  <b>550-5015-XX</b>	<b>STARBURST BULLET</b>  <b>550-5016-XX</b>	<b>STARBURST TRIANGLE</b>  <b>550-5017-XX</b>

**Note:** The shapes and sizes shown above are not to scale. Some shapes may no longer be available in every color.

**Instructions:** Parts which may come in various colors (i.e. targets, some posts, playfield inserts, etc.) end in a 2-digit number which correspond to the color of that part. The "-XX" in part number which may come in various colors should be replaced with the desired 2-Digit number corresponding to the color desired below. *Not all colors may be available.*

PLASTIC PART COLOR CHART											
Nº	Color	Nº	Color	Nº	Color	Nº	Color	Nº	Color	Nº	Color
-00	Black or Solid Clear	-03	Amber	-06	Yellow	-09	Purple	-12	Fluor. Blue	-15	Luminescent
-01	Clear	-04	Green	-07	Orange	-10	Fluor. Orange	-13	Teal Green	-16	Gold
-02	Red	-05	Blue	-08	White	-11	Fluor. Green	-14	Gray	-17	Trans. Brown

# APPENDIX I

## Anti-Loft Stand-Up Targets

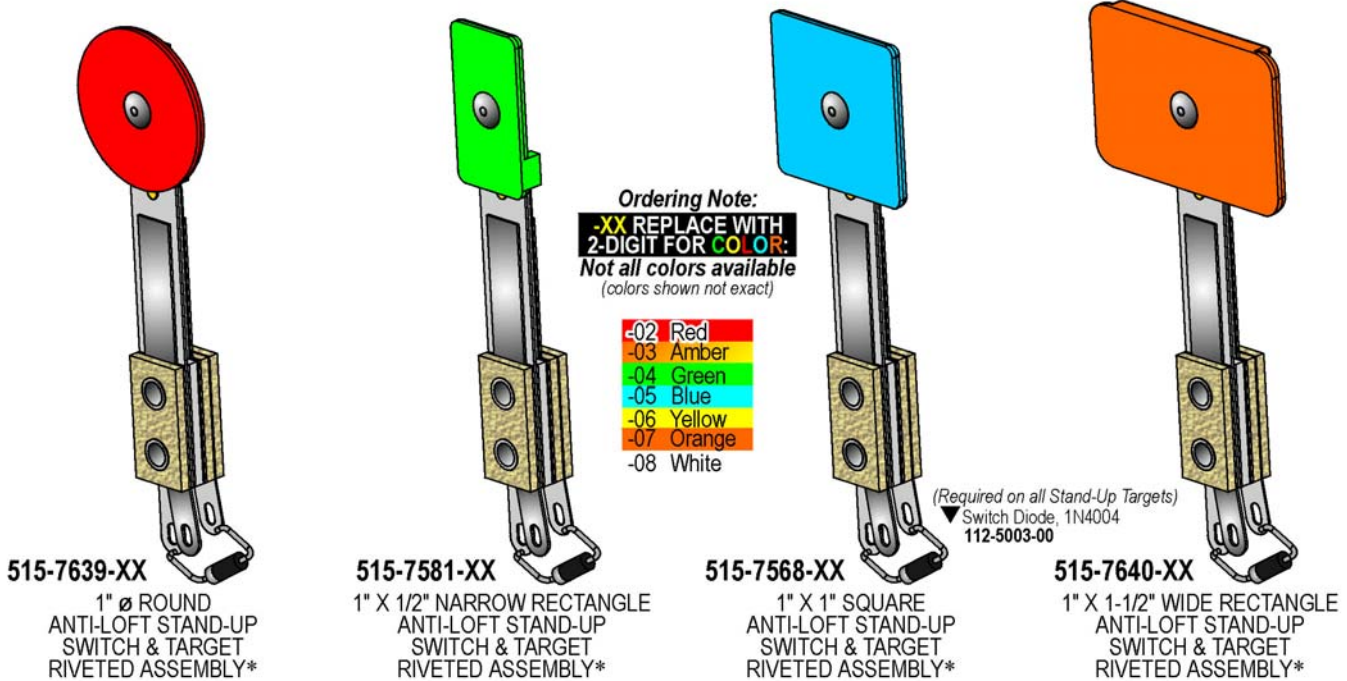

\*Some targets may require the lugs position be changed to the left or to the right, depending on the application; these targets will have a different part number and are called out in the game manual they are used in (see Section 4, Chapter 1, Parts Identification & Location, Playfield ... -Switches.) Review the game manual for the game desired for the original target used or application.

**For Anti-Loft Application use**  
 Large Foam Pad,  
 5/8" X 7/16" X 3/16" Thick  
**626-5078-00**

**For > Light < Anti-Loft Application use**  
 Small Foam Pad,  
 7/16" X 7/16" X 1/8" Thick  
**626-5029-00**

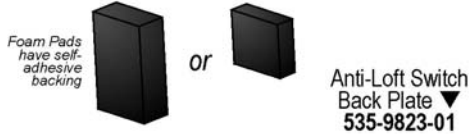

ASM. REF. IN-HOUSE USE ONLY:  
**Light** Anti-Loft Stand-Up Target Assemblies which includes the Anti-Loft Switch Back Plate, Switch Mounting Bracket and Foam Pad (Small): 500-5835-XX (ROUND), 500-5857-XX (NARROW), 500-5232-XX (SQUARE) and 500-5321-XX (RECTANGLE).

Anti-Loft Stand-Up Target Assemblies which includes the Anti-Loft Switch Back Plate, Switch Mounting Bracket and Foam Pad (Large): 500-7082-XX (ROUND), 500-6985-XX (NARROW), 500-6984-XX (SQUARE) and 500-7063-XX (RECTANGLE).

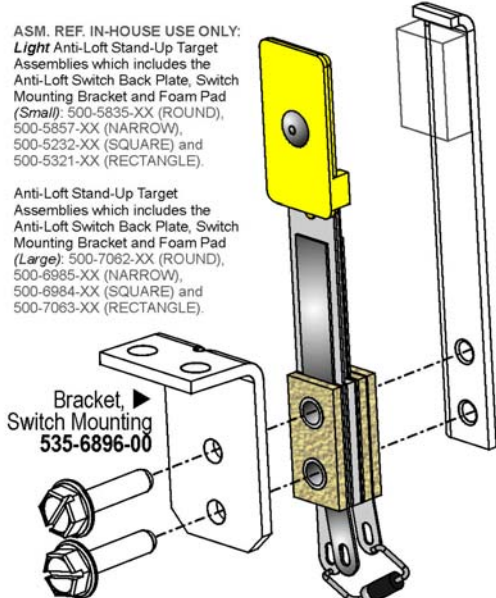

▲ #6-32 X 5/8" Slotted HWH Swage (Zinc) Screws (Qty. 2/per) **237-5976-04**

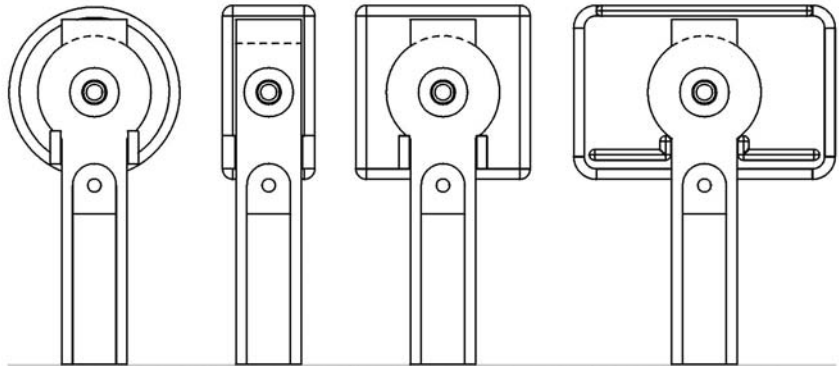

### REAR VIEWS OF ANTI-LOFT TARGET & SWITCH ASSEMBLIES

The material of the Anti-Loft Switch has been extended higher to be used with the Anti-Loft Switch Back Plate. **IMPORTANT:** Switch & Target Assemblies (X) without the extension (the predecessors) **SHOULD NOT** be used with an Anti-Loft Switch Back Plate (shown left).

APPENDIX REFERENCE FOR PINBALL GAMES WHICH USED THE BELOW SWITCH & TARGET ASSEMBLIES NOTE:

The Switch & Target Assemblies (X) without the extension have the following part numbers\*: 515-5966-XX (Round), 515-5967-XX (Narrow), 515-5162-XX (Square) and 515-6027-XX (Rectangle) and should only be used with the Switch Back Plate (shown right), 535-6452-00 and Small Foam Pad, 626-5029-00.

\* If the above referenced part numbers are no longer available from the factory or your distributor, it will be substituted with the appropriate Anti-Loft counterpart. Not all colors may be available.

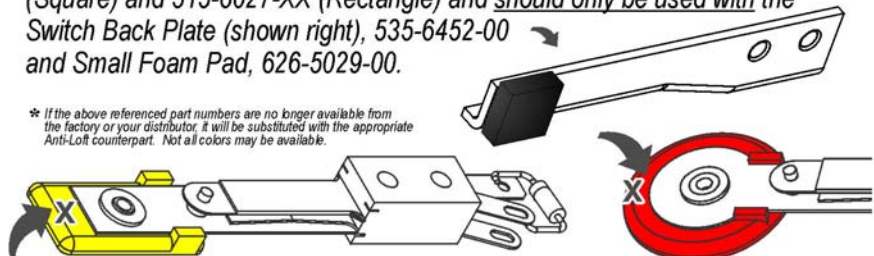

# APPENDIX I

## Modular Stand-Up Targets

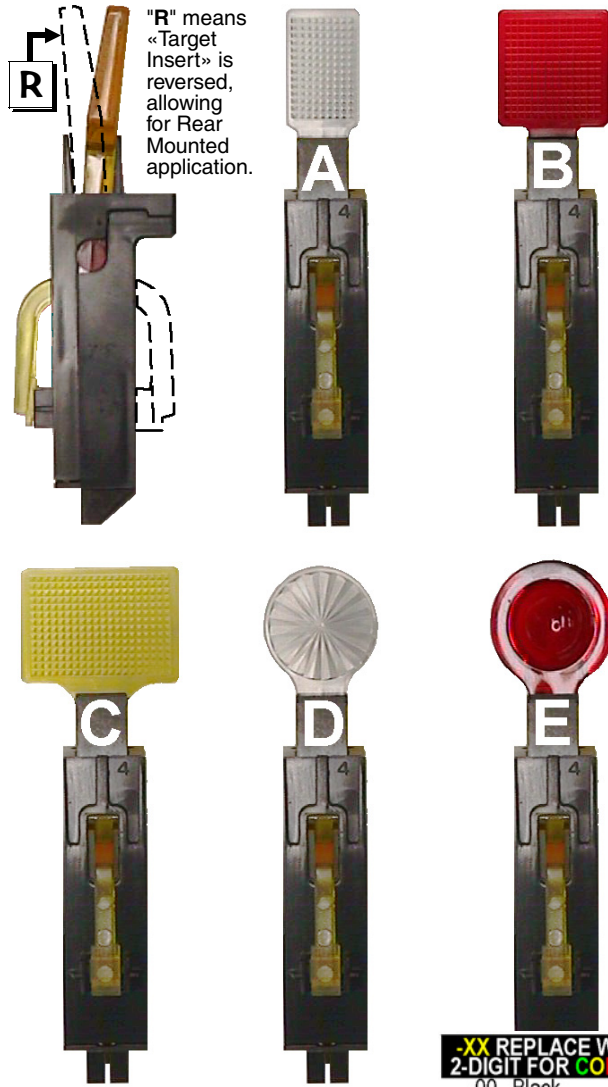

"R" means «Target Insert» is reversed, allowing for Rear Mounted application.

### To Replace the « Target Insert » or change Target Orientation :

**Items A-E Note:** For the Target Assembly use the "500-" SPI Part Number(s) shown in the Parts Table below. To receive the Target Assembly with the « Target Insert » « Reversed » simply add a "R" at the end of the Part Number. See Side View picture left to compare (dashed line shows target reversed). For just the «Target Insert» use the "545-" SPI Part Number.



### To reverse it yourself or to just change the insert:

1. With a small flat head screwdriver, push into the small tab at the bottom of the target front and give a slight twist motion to "pop" the two halves.

2. Push the Target Insert bottom in at the same time while you slide the top (front) part up, then let go of the insert as the two halves come apart.

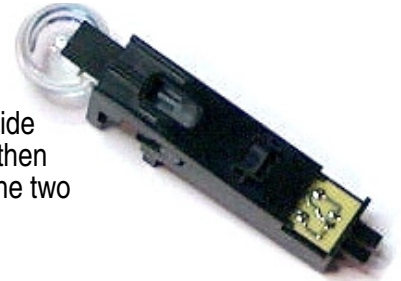

3. Replace target or reinsert it into the other size while sliding the two halves back together.

**Note:** If you were reversing the orientation, don't forget to also turn the Switch Actuator PCB 180°. Test Switch.

### Take Note:

- Items A-E come in various colors. These targets may not be available in every color. The "-XX" in should be replaced with the desired 2-Digit number for the color desired as described in the Color Chart below. As of print date, the following colors were used :  
 -01 Clear (A, D); -02 Red (A, B, C, D, E); -03 Amber (D, E);  
 -04 Green (A, B); -05 Blue (C); -06 Yellow (A, C),  
 -09 Purple (B, D); -11 Fluorescent Green (A, B, D)
- For location(s) and type of Stand-Up Targets used, if any, see Section 4, Chapter 1, Parts Identification & Location.

### -XX REPLACE WITH 2-DIGIT FOR COLOR:

- 00 Black
  - 01 Clear
  - 02 Red
  - 03 Amber
  - 04 Green
  - 05 Blue
  - 06 Yellow
  - 07 Orange
  - 08 White
  - 09 Purple
  - 10 Fluor. Orange
  - 11 Fluor. Green
  - 12 Fluor. Blue
  - 13 Teal Green
  - 14 Gray
  - 15 Luminescent
  - 16 Gold
- Note: Not all colors available.

Nr.	STAND-UP TARGET PARTS	SPI PART Nr.
A	Modular Stand-Up Target Narrow Assy.	500-6138-XX
	Stand-Up Target Narrow (Insert)	545-6138-XX
B	Modular Stand-Up Target Square Assy.	500-6139-XX
	Stand-Up Target Square (Insert)	545-6139-XX
C	Modular Stand-Up Target Rectangle Assy.	500-6228-XX
	Stand-Up Target Rectangle (Insert)	545-6228-XX
D	Modular Stand-Up Target Round Assy.	500-6075-XX
	Stand-Up Target Round (Insert)	545-6075-XX
E	Mod. Stand-Up Target 1" Spherical Assy.	500-6189-XX
	Stand-Up Target 1" Spherical (Insert)	545-6189-XX

# APPENDIX J

## Coin Cards (USA & International Pricing Defaults) ▶ For Yellow Stock add -Y to the Part Number

If more than one Pricing Scheme is available for countries listed, the **F.** listed beside the option, denotes the Factory Default Setting.  
**FOR VIEWS OF THE LATEST or OPTIONAL USA, INTERNATIONAL / EURO AND CUSTOM COIN CARDS, VISIT OUR WEBSITE.**  
 Not Shown USA 755-5400-10 Tournament Option \$2 = X1; 755-5400-11 Tournament Option \$1.50 = X1

<b>USA 10 F.</b>  755-5400-11 Front		<b>USA 10</b>  755-5400-11 Back		<b>USA 2-7 or CANADA</b>  755-5400-02 Front		<b>FOR CUSTOM PRICING †</b>  755-5400-01, -02 or -04 Back		<b>USA 3 with ToPS™</b>  755-5400-03 or -09 Front		<b>USA 5 with ToPS™</b>  755-5400-03 Back / -08 Front	
<b>AUSTRALIA 1 F.</b>  755-5406-00 Front		<b>AUSTRALIA 2</b>  755-5406-00 Back		<b>CROATIA</b>  755-5410-00 Front		<b>FOR CUSTOM PRICING †</b>  755-5410-00 Back		<b>DENMARK 1 F.</b>  755-5402-00 Front		<b>DENMARK 2</b>  755-5402-00 Back	
<b>JAPAN 1</b>  755-5408-01 Front		<b>JAPAN 2 F.</b>  755-5408-01 Back		<b>MIDDLE EAST</b>  755-5400-06 Front		<b>ANY COUNTRY CAN USE</b>  755-5400-06 Back		<b>NEW ZEALAND 1 F.</b>  755-5406-00 Back		<b>NEW ZEALAND 2</b>  755-5406-00 Front	
<b>NORWAY 1 F.</b>  755-5403-01 Front		<b>NORWAY 2</b>  755-5403-01 Back		<b>RUSSIA F.</b>  755-5411-00 Front		<b>RUSSIA (ALTERNATE)</b>  755-5411-00 Back		<b>SOUTH AFRICA</b>  755-5409-01 Front		<b>FOR CUSTOM PRICING †</b>  755-5409-01 Back	
<b>SWEDEN 1 F.</b>  755-5404-00 Front		<b>SWEDEN 2</b>  755-5404-00 Back		<b>SWITZERLAND 1 F.</b>  755-5405-00 Front		<b>SWITZERLAND 2</b>  755-5405-00 Back		<b>TAIWAN</b>  755-5412-00 Front		<b>FOR CUSTOM PRICING †</b>  755-5412-00 Back	
<b>UK 1</b>  755-5407-00 Front		<b>UK 3</b>  755-5407-00 Back		<b>UK 5 F.</b>  755-5407-01 Front		<b>FOR CUSTOM PRICING †</b>  755-5407-01 Back		<b>Appendix J Notes:</b> 1. Coin Card on Game is determined by original shipping country destination. 2. Optional Coin Card(s), are available via your distributor or via free download @ <a href="http://www.sterpinball.com/coinagecards.shtml">www.sterpinball.com/coinagecards.shtml</a> . Older style Coin Cards (foreign or domestic) not available on our website or no longer available through your distributor, are obsolete. 3. Coin Cards which have a Blank Backside can be used for †Custom Pricing.			

Not Shown EURO 755-5401-20 Tournament Custom (can fill in your own pricing).

<b>EURO 1</b>  755-5401-01 1-Side Only		<b>EURO 2</b>  755-5401-02 1-Side Only		<b>EURO 3</b>  755-5401-03 1-Side Only		<b>EURO 4</b>  755-5401-04 1-Side Only		<b>EURO 5</b>  755-5401-05 1-Side Only		<b>EURO 6</b>  755-5401-06 1-Side Only	
<b>EURO 7</b>  755-5401-07 1-Side Only		<b>EURO 8</b>  755-5401-08 1-Side Only		<b>EURO 9</b>  755-5401-09 1-Side Only		<b>EURO 10</b>  755-5401-10 1-Side Only		<b>EURO 11</b>  755-5401-11 1-Side Only		<b>EURO 12</b>  755-5401-12 1-Side Only	

### ▶ EURO FACTORY DEFAULT SUMMARY TABLE ◀

EURO 1	EURO 2	EURO 3	EURO 4	EURO 5	EURO 6	EURO 7	EURO 8	EURO 9	EURO 10	EURO 11	EURO 12
BELGIUM ITALY 1 PORTUGAL	GERMANY 2	NETHERLANDS SPAIN			GREECE		FINLAND	AUSTRIA	FRANCE		

Section 3, Chapter 4, GO TO ADJUSTMENTS MENU, Adj. 18, Game Pricing, USA & International (non-Euro) and Euro 1-12 Summary & International (Euro) Standard Pricing Select Tables, summarizes Standard or Custom Pricing Schemes & the Dip Switch Setting required.

