

Find-It-In-Front: Dr. Pinball Section

The inside cover & the front 16 pages cover the basics:
Fuses, Matrixes, Adjustments, Audits and more!

Section 3 details the Service Menu!

Diagnostics, Audits, Adjustments, Utilities
(Installs, USB, etc.) and Tournament information!

Find-It-In-Front Dr. Pinball Section	Section 1 After Set-Up	Section 2 Game Op. & Features	Section 3 Service Menu System	Section 4 (Pink) Parts ID. & Location	Section 4 (Blue) Drawings for Major...	Sec. 5 (Yellow) Schematics, Wiring ...	Appendixes A - J Historical Data
---	---------------------------	----------------------------------	----------------------------------	--	---	---	-------------------------------------

Shrek, Ears and Shrek "S" TM & © 2008 DreamWorks L.L.C., Shrek Evergreen TM & © 2008 DreamWorks Animation L.L.C. Stern Pinball, Inc. All Rights Reserved.

Your Parts Sales & Technical Support Team



Joe Blackwell
DIRECTOR,
Parts Sales &
Technical Support



Patrick Powers
Technical Support
ENGINEER



Chas Siddiqi
Technical Support
ENGINEER



Dorothy Brown
Parts Sales
SUPERVISOR



J. Alfer
Technical Support
Documentation
ADMINISTRATOR

Pinball Service Game Manual

Please call, eMail or visit us online for technical support, questions or comments regarding this pinball game.

Go to www.sternpinball.com and click Tech. Support & Parts Sales



Find Service Game Manual (with updates), Game Code, Appendixes, Coin Cards, Service Bulletins and much more!

• Toll-Free: 1-800-KICKERS (542-5377) or 1-708-345-7700 • eMail: parts.service@sternpinball.com •

Stern® Pinball, Inc.
All Rights Reserved.
Printed in the U.S.A.
January 2008

SPI Part Number
780-50A5-01

HOW TO UPDATE YOUR GAME CODE FOR THE NEW S.A.M. SYSTEM

USB Compatible Memory Stick (aka Thumb, Flash or Jump Drives) required to copy game code into system. S.A.M. System compatible, tested & SPI approved USB Memory Sticks 128MB+ available through your local distributor: Ask for **SPI Part Number 970-0128-00**

* to get the Memory Stick with the latest **Game Code** copied to it, add "**the game title name**" to above part number.

STYLE, COLOR, SIZE AND MANUFACTURER SUBJECT TO CHANGE.

Game Code is subject to change. Update this game with the latest code downloaded from our website, from another game or order through your local distributor (use SPI PN + name above).

Upon power-up the display will describe the version of code installed in your game. When directed to do so (via Service Bulletin or website announcement) you will need to update your code ... with the **BOOT FLASH EPROM*** installed, **here's how:**



● **Green Button**
Press to **Escape Back** (or **Exit**).

●● **Red Buttons**
Press to move **< Left, Right >**. Press to **- Decrease** or **+ Increase** values or to change settings.

● **Black Button**
Press to **Enter Select** (or **'OK'**).

- STEP 1** Open the Back Box and locate the **8-Position Dip Switch (SW1 on the CPU/Sound Board)**.
- STEP 2** Switch Dip Switch #8 to 'ON'.
(***BOOT FLASH EPROM** must be installed.)
- STEP 3** Press the **White Reset Button (S1 RESET on the CPU/Sound Board)** or Power Cycle the game **OFF/ON** (ON/OFF Switch is located on the outside of the cabinet bottom, front right).
- STEP 4** Using the **4-Button Service Switch Set** (inside the Coin Door):
 - 4A }** Press [**SELECT**] to begin.
 - 4B }** With the "UPDT" *Icon highlighted*, press [**SELECT**].
 - 4C }** Insert the Memory Stick [with latest file(s)] into the USB Port.
 - 4D }** If more than one file is present on the Memory Stick, press [**<**] or [**>**] to locate your file. Press [**SELECT**] to update.
 - 4E }** Follow on-screen prompts.

CPU/Sound Board (S.A.M. System)

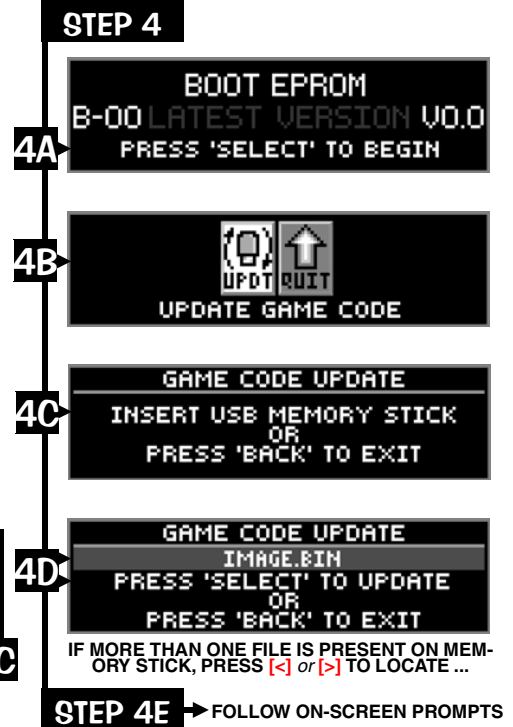
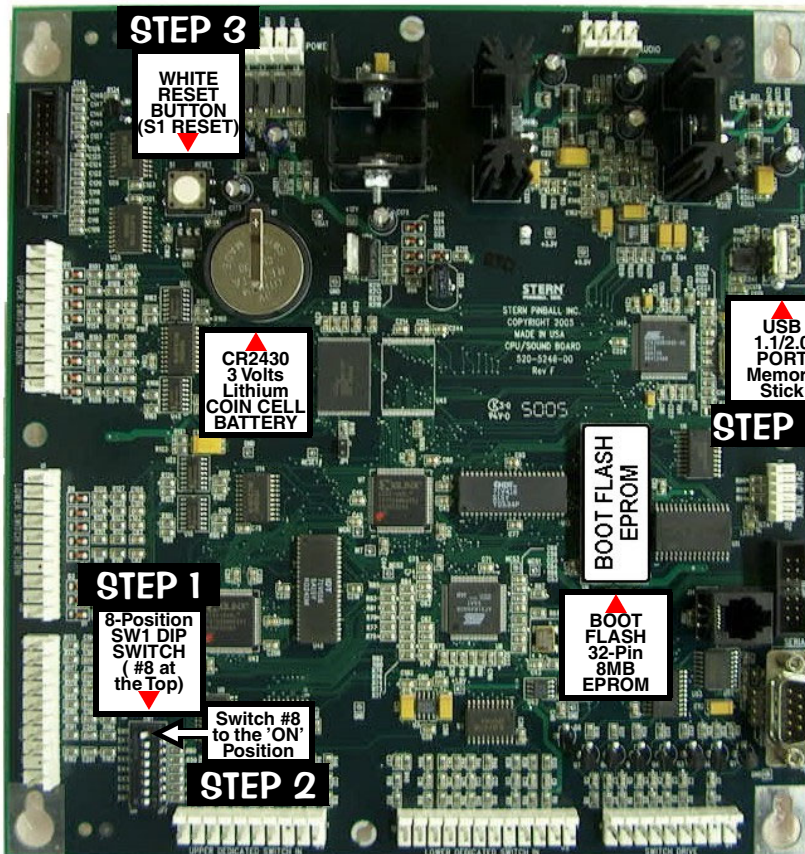

You can also retrieve your latest code from another game! From the **USB MENU** via the **UTILITIES MENU**, select the "BKUP" *Icon* instead and download to your Memory Stick. Review the end of Section 3, Chapter 5.



! Quick Tip ~ Try backing up your current code prior to installing your new code, just in case your Memory Stick file was corrupted by a computer glitch while you were copying / downloading.

Got confused? Comments? Questions? Call Technical Support at 800-542-5377 or 708-345-7700 (Option 1).

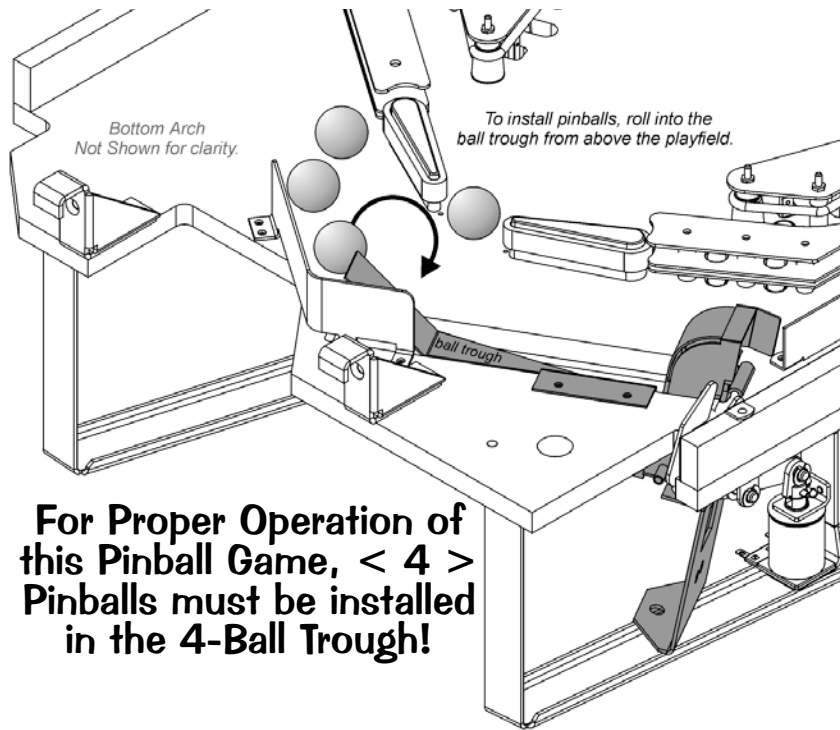

For Proper Operation of this Pinball Game, < 4 > Pinballs must be installed in the 4-Ball Trough!

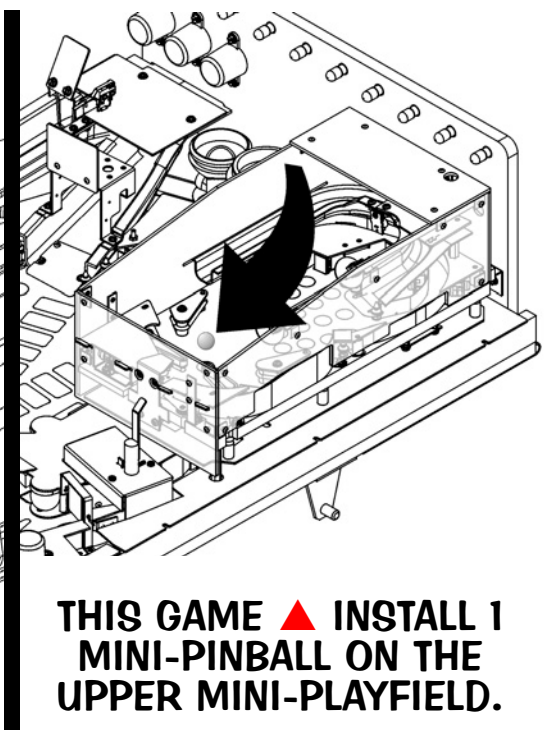

THIS GAME ▲ INSTALL 1 MINI-PINBALL ON THE UPPER MINI-PLAYFIELD.

Backbox Fuses*, Cabinet Fuses, Playfield Fuses and Cabinet Switches

**Note: The CPU/Sound PCB does not have fuses.*

QUICK REFERENCE FUSE CHART									
3/4A S.B. 200-5000-17 3A S.B. 200-5000-08 4A S.B. 200-5000-06 5A S.B. 200-5000-01 7A S.B. 200-5000-03 8A S.B. 200-5000-05									
BACKBOX FUSES					CABINET FUSES				
I/O POWER DRIVER BOARD					POWER (SERVICE OUTLET) BOX				
<i>with RED LED STATUS INDICATORS (if any RED LED is OFF, check the fuse)</i>									
F1	5A S.B.	5.7VAC	G.I. Lamps	[BROWN-WHITE↔WHT-BRN]	8A S.B.	110-120V	Main Line	US / Canada / Japan	
F2	5A S.B.	5.7VAC	G.I. Lamps	[YELLOW↔WHITE-YEL Circuit]	5A S.B.	220-240V	Main Line	International	
F3	5A S.B.	5.7VAC	G.I. Lamps	[GREEN↔WHITE-GRN Circuit]					
F4	5A S.B.	5.7VAC	G.I. Lamps	[VIOLET↔WHITE-VIO Circuit]					
F5	7A S.B.	50VDC	Coils / Flippers	[48VAC feed to BRDG 1]					
F6	3A S.B.	24VAC	Motor or Special Application						
F7	4A S.B.	50VDC	Magnet(s) or Special Application						
F8	3A S.B.	50VDC	Coils						
F9	8A S.B.	18VDC	Control Lamps	[13VAC feed to BRDG 4]					
F10	5A S.B.	20VDC	Coils / Flashers	[16VAC feed to BRDG 2]					
F11	4A S.B.	5VDC	Logic Power	[8VAC feed to BRDG 5]					
F12	5A S.B.	12VDC	Audio	[19VAC feed to BRDG 3]					
F13	5A S.B.	12VDC	Audio	[19VAC feed to BRDG 3]					
PLAYFIELD FUSES									
FLIPPER OR SPECIAL APPLICATION									
<i>(Coil Fuses are located under the playfield near assembly.)</i>									
3A S.B.	50VDC	R. Flipper	[BLU-YEL↔RED-YEL]						
3A S.B.	50VDC	L. Flipper	[GRY-YEL↔RED-YEL]						
3A S.B.	50VDC	Additional Flipper Coil, if used.							
3A S.B.	50VDC	Spcl. Application Coil, if used.							
<i>For location & more details on fuses, see Sec. 5, Chp. 2.</i>									
DISPLAY POWER SUPPLY BOARD									
F1	3/4A S.B.	90VDC	High Voltage Dot Display Board						
<p>ALL FUSES ARE 250V S.B. (SLO-BLO) SEE FUSE OR TABLES FOR AMP RATING</p> <p>CAUTION : FOR CONTINUED PROTECTION AGAINST RISK OF FIRE, REPLACE ONLY WITH SAME TYPE FUSE WITH IDENTICAL ELECTRICAL RATING!</p> <p>Stern Pinball®, Inc. ©2006 820-6384-00 Rev. A</p>									

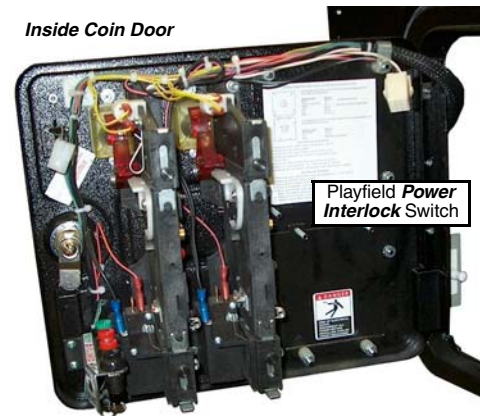

4-Button Switch Set:
For operational usage, see Sec. 3, Chapter 1, Service Menu Introduction.

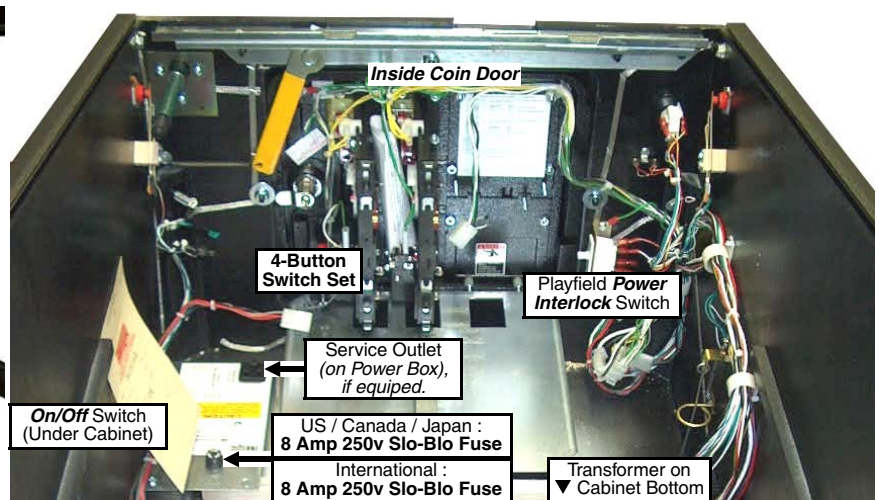

**Find-It-In-Front:
Dr. Pinball**



////// FIND-IT-IN-FRONT: Dr. Pinball Section Explained ////

The key technical data from various parts of the manual were extracted and combined into the "Find- It-In-Front: Dr. Pinball Section." This front section (Pages DR. ① - ⑯) will assist the technician in locating important technical information needed to troubleshoot the Pinball Machine. To enter the **SERVICE MENU**, read below.

● ● ● ● Service Switch X4 Set Overview

The four buttons (inside Coin Door) have dual functions depending if you have entered the **Service Menu** or not.

Functions in Game or Attract Mode

- **Green Button**
Press for **Service Credit(s)**.
- **Red Buttons**
Press for **Volume Adjustment** - for less (quieter), + for more (louder)
- **Black Button**
Press for **Service Menu entry**.

Functions in the Service Menu

Press ● **SELECT** for **SERVICE MENU** -01E

- **Green Button**
Press to **Escape Back** (or **Exit**).
- **Red Buttons**
Press to move **< Left , Right >**. Press to - **Decrease** or + **Increase** values or to change settings.
- **Black Button**
Press to **Enter Select** (or **'OK'**).

OPEN THE COIN DOOR TO ACCESS THE SERVICE SWITCH X4 SET.

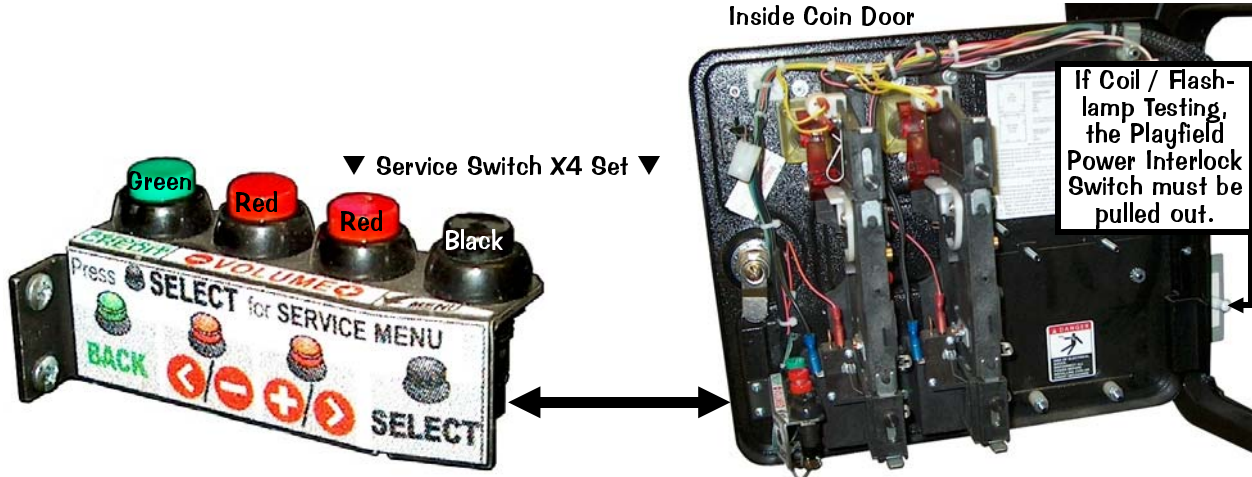

EXAMPLE:

To enter the **SERVICE MENU**, then enter the **SWITCH TEST MENU** via the **DIAGNOSTIC MENU**, perform the below steps.

Step 1 Press [**SELECT**].

Step 2 With the "DIAG" *Icon* highlighted, press [**SELECT**].

Step 3 With the "SW" *Icon* highlighted, press [**SELECT**].

Step 4 With the "TEST" *Icon* highlighted, press [**SELECT**].

Press any switch. If wired correctly, the information in the display will match the information in the Switch Matrix (see DR. 4).

Press [**<**] or [**>**] to move left or right through the menus.

Press [**BACK**] to go back a menu, exit or escape at any time.

Continue through the other menus.

More details & information about the **SERVICE MENU** is covered in Section 3. *The Service Menu is subject to change. Update this game with the latest code downloaded from our website with a USB Memory Stick (64MB min., recommendation 128MB or higher). See the inside front cover for directions or in the Service Menu "Go To Utilities Menu" then "Go To USB Menu" and follow prompts.*



DIAGNOSTIC AIDS

50V / 20V DISABLED
 CLOSE COIN DOOR
 OR PULL INTERLOCK SWITCH
 TO RESTORE POWER

This **audible / visual alert display** is shown when the **50V / 20V Power** is disabled (by opening the Coin Door). **PULL OUT THE INTERLOCK SWITCH ONLY WHILE IN THE SERVICE MENU FOR COIL, SWITCH OR PLAY TESTING WHEN THE COIN DOOR IS REQUIRED TO STAY OPEN FOR SERVICE BUTTON USE!** Pulling out the Power Interlock Switch or pressing the

'escape' **Green [BACK] Button** will remove the alert display. Initial display presentation is accompanied by 3 audible tones (the bright display warning will go dim after approximately 30 seconds).

OPERATOR ALERT!
 AUTO PLUNGER
 DEVICE MALFUNCTION

This **alert display** is shown momentarily during **Game Mode** or **Power-Up** to alert the operator of a device malfunction (device or mechanism doesn't energize or is energized repeatedly).

OPERATOR ALERT! works by monitoring any switch activated device that has the potential to trap a ball when disabled (e.g. in the Shooter Lane, Scoop or Eject Holes, etc.). This alert can also appear if a switch associated with a device (e.g. Ball Trough, Auto Plunger, etc.) is stuck closed (caused by a switch jam or stuck ball); the game will activate the device a predetermined number of times and if the problem is still detected, this device or switch will be noted in **Switch Alerts** (Page 14) and/or **Technician Alerts** (Page 18).

V0.00 GAME NAME HDW. 0
 SYS. 0.00
SERVICE MENU *
 USE -/+ TO VIEW TECH. ALERTS

Upon entering the **SERVICE MENU**, if an asterisk " * " is displayed after the words "SERVICE MENU," the game has detected possible faulty devices, switches and/or missing pinballs. Press the either of the **Red Buttons** (short-cut to the **TECHNICIAN ALERTS MENU**) or continue into the **SERVICE MENU** (press the **Black Button** again), select the "DIAG" Icon and "TECH" Icon for the **Technician Alerts** information (Page 18).

CPU DIP SWITCH SETTINGS

The 8-Pos. Dip Switch [SW1] is on the CPU/Sound Board (between Conn. J3 & J13, lower left corner)

CPU COUNTRY SETTING:	Pos:	1	2	3	4	5	6	7	8
USA	ON								
	OFF	▼	▼	▼	▼	▼	▼	▼	▼

CPU COUNTRY SETTING:	Pos:	1	2	3	4	5	6	7	8
France	ON	▲	▲						
	OFF	▼	▼	▼	▼	▼	▼	▼	▼

CPU COUNTRY SETTING:	Pos:	1	2	3	4	5	6	7	8
Portugal	ON	▲				▲			
	OFF	▼	▼	▼	▼	▼	▼	▼	▼

CPU COUNTRY SETTING:	Pos:	1	2	3	4	5	6	7	8
Austria	ON	▲							
	OFF	▼	▼	▼	▼	▼	▼	▼	▼

CPU COUNTRY SETTING:	Pos:	1	2	3	4	5	6	7	8
Germany	ON	▲	▲	▲					
	OFF	▼	▼	▼	▼	▼	▼	▼	▼

CPU COUNTRY SETTING:	Pos:	1	2	3	4	5	6	7	8
Russia	ON	▲			▲	▲			
	OFF	▼	▼	▼	▼	▼	▼	▼	▼

CPU COUNTRY SETTING:	Pos:	1	2	3	4	5	6	7	8
Australia	ON	▲		▲	▲				
	OFF	▼	▼	▼	▼	▼	▼	▼	▼

CPU COUNTRY SETTING:	Pos:	1	2	3	4	5	6	7	8
Greece	ON	▲	▲	▲	▲				
	OFF	▼	▼	▼	▼	▼	▼	▼	▼

CPU COUNTRY SETTING:	Pos:	1	2	3	4	5	6	7	8
So. Africa	ON			▲		▲			
	OFF	▼	▼	▼	▼	▼	▼	▼	▼

CPU COUNTRY SETTING:	Pos:	1	2	3	4	5	6	7	8
Belgium	ON	▼	▲						
	OFF	▼	▼	▼	▼	▼	▼	▼	▼

CPU COUNTRY SETTING:	Pos:	1	2	3	4	5	6	7	8
Italy	ON				▲				
	OFF	▼	▼	▼	▼	▼	▼	▼	▼

CPU COUNTRY SETTING:	Pos:	1	2	3	4	5	6	7	8
Spain	ON	▼	▲			▲			
	OFF	▼	▼	▼	▼	▼	▼	▼	▼

CPU COUNTRY SETTING:	Pos:	1	2	3	4	5	6	7	8
Canada 1	ON	▲	▲						
	OFF	▼	▼	▼	▼	▼	▼	▼	▼

CPU COUNTRY SETTING:	Pos:	1	2	3	4	5	6	7	8
Japan	ON	▲		▲	▲				
	OFF	▼	▼	▼	▼	▼	▼	▼	▼

CPU COUNTRY SETTING:	Pos:	1	2	3	4	5	6	7	8
Sweden	ON	▲	▲	▲					
	OFF	▼	▼	▼	▼	▼	▼	▼	▼

CPU COUNTRY SETTING:	Pos:	1	2	3	4	5	6	7	8
Canada 2	ON	▲		▲	▲				
	OFF	▼	▼	▼	▼	▼	▼	▼	▼

CPU COUNTRY SETTING:	Pos:	1	2	3	4	5	6	7	8
Middle East	ON	▲	▲	▲	▲				
	OFF	▼	▼	▼	▼	▼	▼	▼	▼

CPU COUNTRY SETTING:	Pos:	1	2	3	4	5	6	7	8
Switzerland	ON	▼	▲	▲					
	OFF	▼	▼	▼	▼	▼	▼	▼	▼

CPU COUNTRY SETTING:	Pos:	1	2	3	4	5	6	7	8
Croatia	ON		▲	▲		▲			
	OFF	▼	▼	▼	▼	▼	▼	▼	▼

CPU COUNTRY SETTING:	Pos:	1	2	3	4	5	6	7	8
Netherlands	ON			▲					
	OFF	▼	▼	▼	▼	▼	▼	▼	▼

CPU COUNTRY SETTING:	Pos:	1	2	3	4	5	6	7	8
Taiwan	ON				▲	▲			
	OFF	▼	▼	▼	▼	▼	▼	▼	▼

CPU COUNTRY SETTING:	Pos:	1	2	3	4	5	6	7	8
Denmark	ON	▲			▲				
	OFF	▼	▼	▼	▼	▼	▼	▼	▼

CPU COUNTRY SETTING:	Pos:	1	2	3	4	5	6	7	8
New Zealand	ON					▲			
	OFF	▼	▼	▼	▼	▼	▼	▼	▼

CPU COUNTRY SETTING:	Pos:	1	2	3	4	5	6	7	8
UK	ON	▼	▲	▲	▲				
	OFF	▼	▼	▼	▼	▼	▼	▼	▼

CPU COUNTRY SETTING:	Pos:	1	2	3	4	5	6	7	8
Finland	ON	▲		▲					
	OFF	▼	▼	▼	▼	▼	▼	▼	▼

CPU COUNTRY SETTING:	Pos:	1	2	3	4	5	6	7	8
Norway	ON		▲	▲					
	OFF	▼	▼	▼	▼	▼	▼	▼	▼

CPU/SND PCB SETTING:	Pos:	1	2	3	4	5	6	7	8
UPDATE CODE	ON								▲
	OFF	▼	▼	▼	▼	▼	▼	▼	▼

Note: Slide Dip Switch 8 to Position **ON** (with Dip Switches 1-7 in the **OFF** Position) only to reboot the game with the latest version **BOOT EPROM** installed at **U9** on the CPU/Sound Board (S.A.M. System only). Currently, this is also the procedure to update your game with the latest software code update file. For the latest version, visit our website. If you have questions about updating your game code, call Technical Support for assistance.



**Find-It-In-Front:
Dr. Pinball**



SWITCH MATRIX GRID [#1 – #64] { Switch Locations on the next page }

CPU/ Sound Board	01 IC-U22A RETURN	02 IC-U22B RETURN	03 IC-U22C RETURN	04 IC-U22D RETURN	05 IC-U16A RETURN	06 IC-U16B RETURN	07 IC-U16C RETURN	08 IC-U16D RETURN	09 IC-U36A RETURN	10 IC-U36B RETURN	11 IC-U36C RETURN	12 IC-U36D RETURN	13 IC-U40A RETURN	14 IC-U40B RETURN	15 IC-U40C RETURN	16 IC-U40D RETURN
SW. # 1	SW. # 2	SW. # 3	SW. # 4	SW. # 5	SW. # 6	SW. # 7	SW. # 8	SW. # 9	SW. # 10	SW. # 11	SW. # 12	SW. # 13	SW. # 14	SW. # 15	SW. # 16	
Q1 DRIVE GRN-BRN J1-P1	Q1 DRIVE GRN-BRN J1-P1	Q1 DRIVE GRN-BRN J1-P1	Q1 DRIVE GRN-BRN J1-P1	Q1 DRIVE GRN-BRN J1-P1	Q1 DRIVE GRN-BRN J1-P1	Q1 DRIVE GRN-BRN J1-P1	Q1 DRIVE GRN-BRN J1-P1	Q1 DRIVE GRN-BRN J1-P1	Q1 DRIVE GRN-BRN J1-P1	Q1 DRIVE GRN-BRN J1-P1	Q1 DRIVE GRN-BRN J1-P1	Q1 DRIVE GRN-BRN J1-P1	Q1 DRIVE GRN-BRN J1-P1	Q1 DRIVE GRN-BRN J1-P1	Q1 DRIVE GRN-BRN J1-P1	
180-501-04 below playfield	180-501-04 below playfield	180-5162-08 below playfield	180-5162-08 below playfield	180-5162-08 below playfield	500-6227-01 below playfield	500-6227-02 below playfield	515-5967-04 below playfield	520-5252-01 below playfield	515-5162-08 below playfield	NOT USED	NOT USED	SWAMP EJECT	NOT USED	TOURNA- MENT START	START BUTTON	
Q2 DRIVE GRN-RED J1-P3	Q2 DRIVE GRN-RED J1-P3	Q2 DRIVE GRN-RED J1-P3	Q2 DRIVE GRN-RED J1-P3	Q2 DRIVE GRN-RED J1-P3	Q2 DRIVE GRN-RED J1-P3	Q2 DRIVE GRN-RED J1-P3	Q2 DRIVE GRN-RED J1-P3	Q2 DRIVE GRN-RED J1-P3	Q2 DRIVE GRN-RED J1-P3	Q2 DRIVE GRN-RED J1-P3	Q2 DRIVE GRN-RED J1-P3	Q2 DRIVE GRN-RED J1-P3	Q2 DRIVE GRN-RED J1-P3	Q2 DRIVE GRN-RED J1-P3	Q2 DRIVE GRN-RED J1-P3	
NOT USED	(4-BALL) TROUGH #4 (L)	(4-BALL) TROUGH #3	(4-BALL) TROUGH #2	(4-BALL) TROUGH #1 (R)	(STACK OPTO) TROUGH JAM	(STACK OPTO) TROUGH JAM	TRANS. / REC. 515-5173-00 Tx 515-0174-00 Rx 515-0174-00	TRANS. / REC. 515-5173-00 Tx 515-0174-00 Rx 515-0174-00	TRANS. / REC. 515-5173-00 Tx 515-0174-00 Rx 515-0174-00	TRANS. / REC. 515-5173-00 Tx 515-0174-00 Rx 515-0174-00	TRANS. / REC. 515-5173-00 Tx 515-0174-00 Rx 515-0174-00	TRANS. / REC. 515-5173-00 Tx 515-0174-00 Rx 515-0174-00	TRANS. / REC. 515-5173-00 Tx 515-0174-00 Rx 515-0174-00	TRANS. / REC. 515-5173-00 Tx 515-0174-00 Rx 515-0174-00	TRANS. / REC. 515-5173-00 Tx 515-0174-00 Rx 515-0174-00	
Q3 DRIVE GRN-ORG J1-P4	Q3 DRIVE GRN-ORG J1-P4	Q3 DRIVE GRN-ORG J1-P4	Q3 DRIVE GRN-ORG J1-P4	Q3 DRIVE GRN-ORG J1-P4	Q3 DRIVE GRN-ORG J1-P4	Q3 DRIVE GRN-ORG J1-P4	Q3 DRIVE GRN-ORG J1-P4	Q3 DRIVE GRN-ORG J1-P4	Q3 DRIVE GRN-ORG J1-P4	Q3 DRIVE GRN-ORG J1-P4	Q3 DRIVE GRN-ORG J1-P4	Q3 DRIVE GRN-ORG J1-P4	Q3 DRIVE GRN-ORG J1-P4	Q3 DRIVE GRN-ORG J1-P4	Q3 DRIVE GRN-ORG J1-P4	
LEFT RAMP MADE	NOT USED	CASTLE GUARD	NOT USED	NOT USED	NOT USED	NOT USED	NOT USED	NOT USED	NOT USED	NOT USED	NOT USED	NOT USED	NOT USED	NOT USED	NOT USED	
Q4 DRIVE GRN-YEL J1-P5	Q4 DRIVE GRN-YEL J1-P5	Q4 DRIVE GRN-YEL J1-P5	Q4 DRIVE GRN-YEL J1-P5	Q4 DRIVE GRN-YEL J1-P5	Q4 DRIVE GRN-YEL J1-P5	Q4 DRIVE GRN-YEL J1-P5	Q4 DRIVE GRN-YEL J1-P5	Q4 DRIVE GRN-YEL J1-P5	Q4 DRIVE GRN-YEL J1-P5	Q4 DRIVE GRN-YEL J1-P5	Q4 DRIVE GRN-YEL J1-P5	Q4 DRIVE GRN-YEL J1-P5	Q4 DRIVE GRN-YEL J1-P5	Q4 DRIVE GRN-YEL J1-P5	Q4 DRIVE GRN-YEL J1-P5	
180-5189-00 a / b playfield	511-5081-00 below mini-pl	511-5081-00 below mini-pl	500-6775-00 mini-playfield	500-6775-00 mini-playfield	500-6775-00 mini-playfield	500-6775-00 mini-playfield	500-6775-00 mini-playfield	500-6775-00 mini-playfield	500-6775-00 mini-playfield	500-6775-00 mini-playfield	500-6775-00 mini-playfield	500-6775-00 mini-playfield	500-6775-00 mini-playfield	500-6775-00 mini-playfield	500-6775-00 mini-playfield	
MAGIC MIRROR (CAN)	MINI MAN TARGET [STAND-UP]	MINI SHREK TARGET [STAND-UP]	MINI LEFT ORBIT	MINI LEFT ORBIT	MINI LEFT ORBIT	MINI LEFT ORBIT	MINI LEFT ORBIT	MINI LEFT ORBIT	MINI LEFT ORBIT	MINI LEFT ORBIT	MINI LEFT ORBIT	MINI LEFT ORBIT	MINI LEFT ORBIT	MINI LEFT ORBIT	MINI LEFT ORBIT	

Wire Color Abbreviations used:

BLK	BLU	BRN	GRY	GRN	LGN	ORG	PNK	RED	TAN	VIO	WHT	YEL
Black	Blue	Brown	Gray	Green	Light Gm.	Orange	Pink	Red	Tan	Violet	White	Yellow

Dedicated Switches (D-1 – D-32) { Dedicated Switch Locations on the next page }

CPU/SND Board	01 IC-U12 RETURN	02 IC-U12 RETURN	03 IC-U12 RETURN	04 IC-U12 RETURN	05 IC-U12 RETURN	06 IC-U12 RETURN	07 IC-U12 RETURN	08 IC-U12 RETURN	09 IC-U12 RETURN	10 IC-U12 RETURN	11 IC-U12 RETURN	12 IC-U12 RETURN	13 IC-U12 RETURN	14 IC-U12 RETURN	15 IC-U12 RETURN	16 IC-U12 RETURN
SW. D-1	SW. D-2	SW. D-3	SW. D-4	SW. D-5	SW. D-6	SW. D-7	SW. D-8	SW. D-9	SW. D-10	SW. D-11	SW. D-12	SW. D-13	SW. D-14	SW. D-15	SW. D-16	
GROUND (BLK) J2-P1/11 & J3-P10	GROUND (BLK) J2-P1/11 & J3-P10	GROUND (BLK) J2-P1/11 & J3-P10	GROUND (BLK) J2-P1/11 & J3-P10	GROUND (BLK) J2-P1/11 & J3-P10	GROUND (BLK) J2-P1/11 & J3-P10	GROUND (BLK) J2-P1/11 & J3-P10	GROUND (BLK) J2-P1/11 & J3-P10	GROUND (BLK) J2-P1/11 & J3-P10	GROUND (BLK) J2-P1/11 & J3-P10	GROUND (BLK) J2-P1/11 & J3-P10	GROUND (BLK) J2-P1/11 & J3-P10	GROUND (BLK) J2-P1/11 & J3-P10	GROUND (BLK) J2-P1/11 & J3-P10	GROUND (BLK) J2-P1/11 & J3-P10	GROUND (BLK) J2-P1/11 & J3-P10	
LEFT COIN SLOT	CENTER SLOT/DBA	RIGHT COIN SLOT	4TH COIN SLOT	5TH COIN SLOT	NOT USED	NOT USED	NOT USED	LEFT FLIPPER BUTTON	LEFT FLIPPER E.O.S.	RIGHT FLIPPER BUTTON	RIGHT FLIPPER E.O.S.	UPR. LT FLIPPER BUTTON	UPR. RT FLIPPER BUTTON	UPR. RT FLIPPER BUTTON	NOT USED	
180-5204-00 Coin Door	180-5204-00 Coin Door	180-5204-00 Coin Door	180-5204-00 Coin Door	180-5204-00 Coin Door	180-5164-01 Cabinet Side	180-5149-00 Flipper Asm.	180-5160-01 Cabinet Side	180-5149-00 Flipper Asm.	180-5164-01 Cabinet Side	180-5149-00 Flipper Asm.	180-5164-01 Cabinet Side	180-5149-00 Flipper Asm.	180-5164-01 Cabinet Side	180-5149-00 Flipper Asm.	180-5164-01 Cabinet Side	

CPU/SND Board	01 IC-G41 RETURN	02 IC-G41 RETURN	03 IC-G41 RETURN	04 IC-G41 RETURN	05 IC-G41 RETURN	06 IC-G41 RETURN	07 IC-G41 RETURN	08 IC-G41 RETURN	09 IC-G41 RETURN	10 IC-G41 RETURN	11 IC-G41 RETURN	12 IC-G41 RETURN	13 IC-G41 RETURN	14 IC-G41 RETURN	15 IC-G41 RETURN	16 IC-G41 RETURN
SW. D-17	SW. D-18	SW. D-19	SW. D-20	SW. D-21	SW. D-22	SW. D-23	SW. D-24	SW. D-25	SW. D-26	SW. D-27	SW. D-28	SW. D-29	SW. D-30	SW. D-31	SW. D-32	
GROUND (BLK) J13-P10	GROUND (BLK) J13-P10	GROUND (BLK) J13-P10	GROUND (BLK) J13-P10	GROUND (BLK) J13-P10	GROUND (BLK) J13-P10	GROUND (BLK) J13-P10	GROUND (BLK) J13-P10	GROUND (BLK) J13-P10	GROUND (BLK) J13-P10	GROUND (BLK) J13-P10	GROUND (BLK) J13-P10	GROUND (BLK) J13-P10	GROUND (BLK) J13-P10	GROUND (BLK) J13-P10	GROUND (BLK) J13-P10	
TILT PENDULUM (PLUMB BOB)	SLAM TILT	TICKET NOTCHED	NOT USED	BACK (GREEN BUTTON)	MINUS (5- RED BUTTON)	PLUS (+ / RED BUTTON)	SELECT (BLACK BUTTON)	DIP SWITCH POSITION #1	DIP SWITCH POSITION #2	DIP SWITCH POSITION #3	DIP SWITCH POSITION #4	DIP SWITCH POSITION #5	DIP SWITCH POSITION #6	DIP SWITCH POSITION #7	DIP SWITCH POSITION #8	
See Sec. 4 Cp. 1, Pg. 63 for cab. parts	502-5032-00 Optional Kit	180-5119-02 Below Plf	180-5192-04 Coin Door	180-5192-02 Coin Door	180-5192-02 Coin Door	180-5192-02 Coin Door	180-5192-02 Coin Door	ON / OFF	ON / OFF	ON / OFF	ON / OFF	ON / OFF	ON / OFF	ON / OFF	ON / OFF	

CPU/SOUND BD. SW1 DIP SWITCH (located between Connectors J3/J13)





SWITCH MENU: SWITCH, ACTIVE, SINGLE & SERVICE

SWITCH LOCATIONS

{Switch Matrix Grid [#1 – #64] on the previous page}

THERE ARE NO SWITCHES LOCATED ON THE BACK PANEL.

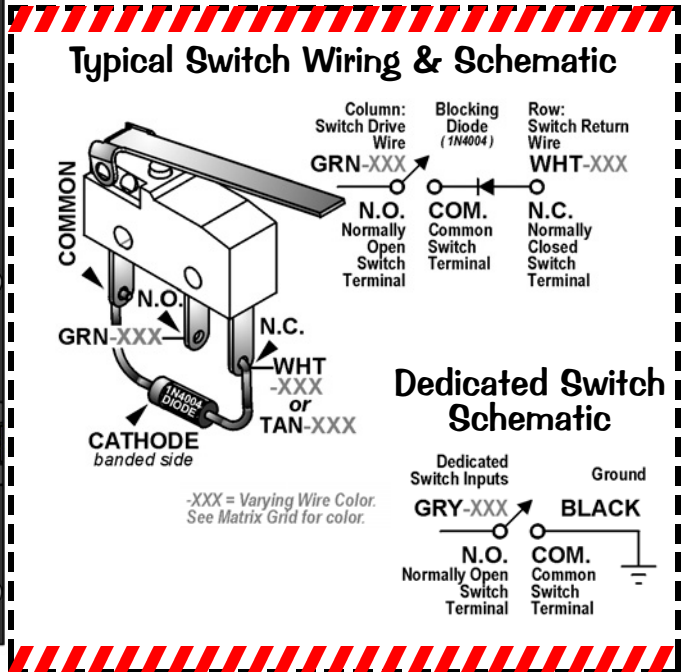
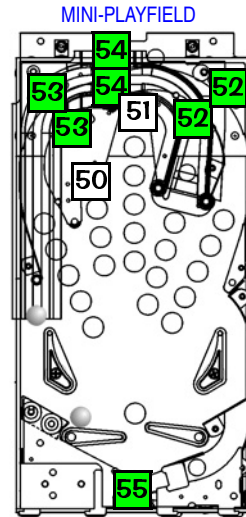
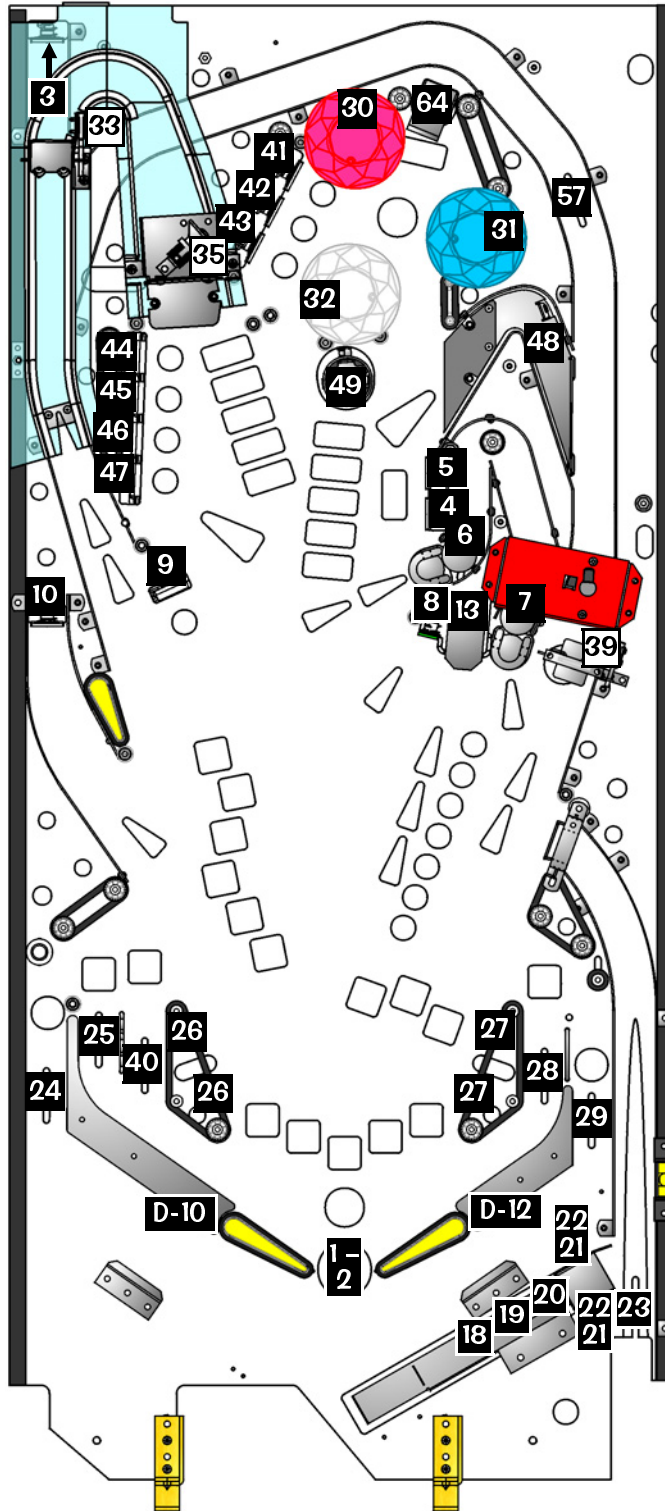

- = Switches above Playfield.
- = Switches below Playfield.
- = OPTO Switch Pairs above.

Switch Part Notes: ¥ Yen Coin Switch is 180-5091-00. Part Numbers which start with 515- or 500- include the bracket, target, and/or housing.

Sw. D-17 Part Note: The Switch is comprised of a Hanger Bracket (535-5319-00) and Contact Wire (535-7563-01) located in the Cabinet.

LAMP MATRIX GRID [#1 - #80] {Lamp Locations on the next page}

I/O	01	02	03	04	05	06	07	08
Power Driver Board	IC-U17 18VDC YEL-BRN J13-P9	IC-U16 18VDC YEL-RED J13-P8	IC-U15 18VDC YEL-ORG J13-P7	IC-U14 18VDC YEL-BLK J13-P6	IC-U13 18VDC YEL-GRN J13-P5	IC-U12 18VDC YEL-BLU J13-P4	IC-U11 18VDC YEL-VIO J13-P3	IC-U10 18VDC YEL-GRY J13-P1
01	Q33 GROUND RED-BRN J12-P1	Q33 GROUND RED-BRN J12-P2	Q34 GROUND RED-BLK J12-P2	Q34 GROUND RED-BLK J12-P2	Q35 GROUND RED-ORG J12-P3	Q36 GROUND RED-YEL J12-P4	Q37 GROUND RED-GRN J12-P5	Q38 GROUND RED-BLU J12-P6
	#555 Clear LP. #1 START BUTTON	#44 Clear LP. #2 TOURNAMENT START BUTTON	#555 Clear LP. #3 SHREK	#44 Clear LP. #4 FIONA	#44 Clear LP. #5 PUSS IN BOOTS	#44 Clear LP. #6 GINGY	#44 Clear LP. #7 PRINCE CHARMING	#44 Clear LP. #8 DONKEY
02	Q34 GROUND RED-BLK J12-P2	Q34 GROUND RED-BLK J12-P2	Q35 GROUND RED-ORG J12-P3	Q35 GROUND RED-ORG J12-P3	Q36 GROUND RED-YEL J12-P4	Q36 GROUND RED-YEL J12-P4	Q37 GROUND RED-GRN J12-P5	Q38 GROUND RED-BLU J12-P6
	#555 Clear LP. #9 (P) INBALL	#44 Clear LP. #10 P (I) NBALL	#44 Clear LP. #11 PI (N) BALL	#44 Clear LP. #12 PIN (B) ALL	#44 Clear LP. #13 PINB (A) LL	#44 Clear LP. #14 PINBAL (L) L	#44 Clear LP. #15 PINBAL (L)	#44 Clear LP. #16 LEFT OUTLANE [EXTRA BALL]
03	Q35 GROUND RED-ORG J12-P3	Q35 GROUND RED-ORG J12-P3	Q35 GROUND RED-ORG J12-P3	Q35 GROUND RED-ORG J12-P3	Q36 GROUND RED-YEL J12-P4	Q36 GROUND RED-YEL J12-P4	Q37 GROUND RED-GRN J12-P5	Q38 GROUND RED-BLU J12-P6
	#555 Clear LP. #17 LEFT RETURN [2X GINGY]	#44 Clear LP. #18 TELL A LIE [LEFT INNER]	#44 Clear LP. #19 BRIDGE TO FIONA	#44 Clear LP. #20 DINNER THEATRE	#44 Clear LP. #21 WRESTLING MATCH	#44 Clear LP. #22 COOKIE CRUMBLES	#44 Clear LP. #23 OGRES ARE ONIONS	#44 Clear LP. #24 (1) [BY RT. SLING]
04	Q36 GROUND RED-YEL J12-P4	Q36 GROUND RED-YEL J12-P4	Q36 GROUND RED-YEL J12-P4	Q36 GROUND RED-YEL J12-P4	Q37 GROUND RED-GRN J12-P5	Q37 GROUND RED-GRN J12-P5	Q38 GROUND RED-BLU J12-P6	Q39 GROUND RED-VIO J12-P8
	#555 Clear LP. #25 [BY RT. SLING]	#44 Clear LP. #26 [BY RT. SLING]	#44 Clear LP. #27 RT RETURN [2X FIONA]	#44 Clear LP. #28 RT. OUTLANE [SPECIAL]	#44 Clear LP. #29 SWAMP [SCOOP]	#44 Clear LP. #30 PINBALL [SCOOP]	#44 Clear LP. #31 MULTIBALL [SCOOP]	#44 Clear LP. #32 FIONA JACKPOT
05	Q37 GROUND RED-GRN J12-P5	Q37 GROUND RED-GRN J12-P5	Q37 GROUND RED-GRN J12-P5	Q37 GROUND RED-GRN J12-P5	Q38 GROUND RED-BLU J12-P6	Q38 GROUND RED-BLU J12-P6	Q39 GROUND RED-VIO J12-P8	Q40 GROUND RED-GRY J12-P9
	#555 Clear LP. #33 FAIRY GOD- MOTHER [STD-UP]	#44 Clear LP. #34 RT. NEWTON JACKPOT	#44 Clear LP. #35 BABY 1 (TOP) [4-BNK DRP/TRG]	#44 Clear LP. #36 BABY 2 [4-BNK DRP/TRG]	#44 Clear LP. #37 BABY 3 [4-BNK DRP/TRG]	#44 Clear LP. #38 BABY 4 (BOT) [4-BNK DRP/TRG]	#44 Clear LP. #39 LEFT ORBIT PUSS (IN BOOTS)	#44 Clear LP. #40 LEFT ORBIT JACKPOT
06	Q38 GROUND RED-BLU J12-P6	Q38 GROUND RED-BLU J12-P6	Q38 GROUND RED-BLU J12-P6	Q38 GROUND RED-BLU J12-P6	Q39 GROUND RED-VIO J12-P8	Q39 GROUND RED-VIO J12-P8	Q40 GROUND RED-GRY J12-P9	Q41 GROUND RED-WHT J12-P10
	#555 Clear LP. #41 PINOCCHIO LIES [1-BNK DRP/TRG]	#44 Clear LP. #42 SKILL SHOT	#44 Clear LP. #43 200K [TO LEFT RAMP]	#44 Clear LP. #44 300K [TO LEFT RAMP]	#44 Clear LP. #45 400K [TO LEFT RAMP]	#44 Clear LP. #46 500K [TO LEFT RAMP]	#44 Clear LP. #47 REPAY YOUR DEBT [TO L RAMP]	#44 Clear LP. #48 RALLY THE VIL- LIANS [MIRROR]
07	Q39 GROUND RED-VIO J12-P8	Q39 GROUND RED-VIO J12-P8	Q39 GROUND RED-VIO J12-P8	Q39 GROUND RED-VIO J12-P8	Q40 GROUND RED-GRY J12-P9	Q40 GROUND RED-GRY J12-P9	Q41 GROUND RED-WHT J12-P10	Q42 GROUND RED J12-P11
	#555 Clear LP. #49 3 LITTLE PIGS [MIRROR]	#44 Clear LP. #50 UN-HAPPY HOUR [MIRROR]	#44 Clear LP. #51 ONCE UPON A TIME [MIRROR]	#44 Clear LP. #52 DRAGON MULTI- BALL [MIRROR]	#44 Clear LP. #53 EXTRA BALL [LEFT NEWTON]	#44 Clear LP. #54 LEFT NEWTON JACKPOT	#44 Clear LP. #55 PUSS IN BOOTS JACKPOT	#44 Clear LP. #56 3 BANK TOP [X STAND-UP]
08	Q40 GROUND RED-GRY J12-P9	Q40 GROUND RED-GRY J12-P9	Q40 GROUND RED-GRY J12-P9	Q40 GROUND RED-GRY J12-P9	Q41 GROUND RED-WHT J12-P10	Q41 GROUND RED-WHT J12-P10	Q42 GROUND RED J12-P11	Q42 GROUND RED J12-P11
	#555 Clear LP. #57 3 BANK MID [X STAND-UP]	#44 Clear LP. #58 3 BANK BOT [X STAND-UP]	NOT USED	NOT USED	LED WB WHT LP. #61 BOTTOM & TOP BUMPERS 112-5024-08	#44 Clear LP. #62 MERLIN [MYSTERY]	#44 Clear LP. #63 DONKEY [STAND-UP X2]	#44 Clear LP. #64 SHOOT AGAIN
09	Q41 GROUND RED-WHT J12-P10	Q41 GROUND RED-WHT J12-P10	Q41 GROUND RED-WHT J12-P10	Q41 GROUND RED-WHT J12-P10	Q42 GROUND RED J12-P11	Q42 GROUND RED J12-P11	Q42 GROUND RED J12-P11	Q42 GROUND RED J12-P11
	#555 Clear LP. #65 RIGHT ORBIT GINGY	#44 Clear LP. #66 RIGHT ORBIT JACKPOT	#44 Clear LP. #67 SPINNER [GINGY]	#44 Clear LP. #68 MINI-PLAYFIELD SHOOT AGAIN	NOT USED	NOT USED	NOT USED	NOT USED
10	Q42 GROUND RED J12-P11	Q42 GROUND RED J12-P11	Q42 GROUND RED J12-P11	Q42 GROUND RED J12-P11	Q42 GROUND RED J12-P11	Q42 GROUND RED J12-P11	Q42 GROUND RED J12-P11	Q42 GROUND RED J12-P11
	NOT USED	NOT USED	NOT USED	NOT USED	NOT USED	NOT USED	NOT USED	NOT USED

Wire Color Abbreviations used:

BLK Black
 BLU Blue
 BRN Brown
 GRY Gray
 GRN Green
 ORG Orange
 RED Red
 VIO Violet
 WHT White
 YEL Yellow



Find-It-In-Front:
Dr. Pinball



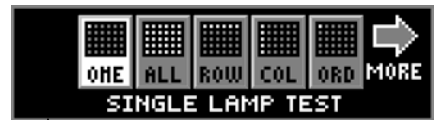

LAMP MENU: ONE, ALL, ROW, COLUMN & ORDERED

LAMP LOCATIONS

{Lamp Matrix Grid [#1 – #80] on the previous page}

THERE ARE NO CONTROLLED LAMPS LOCATED ON THE BACK PANEL.

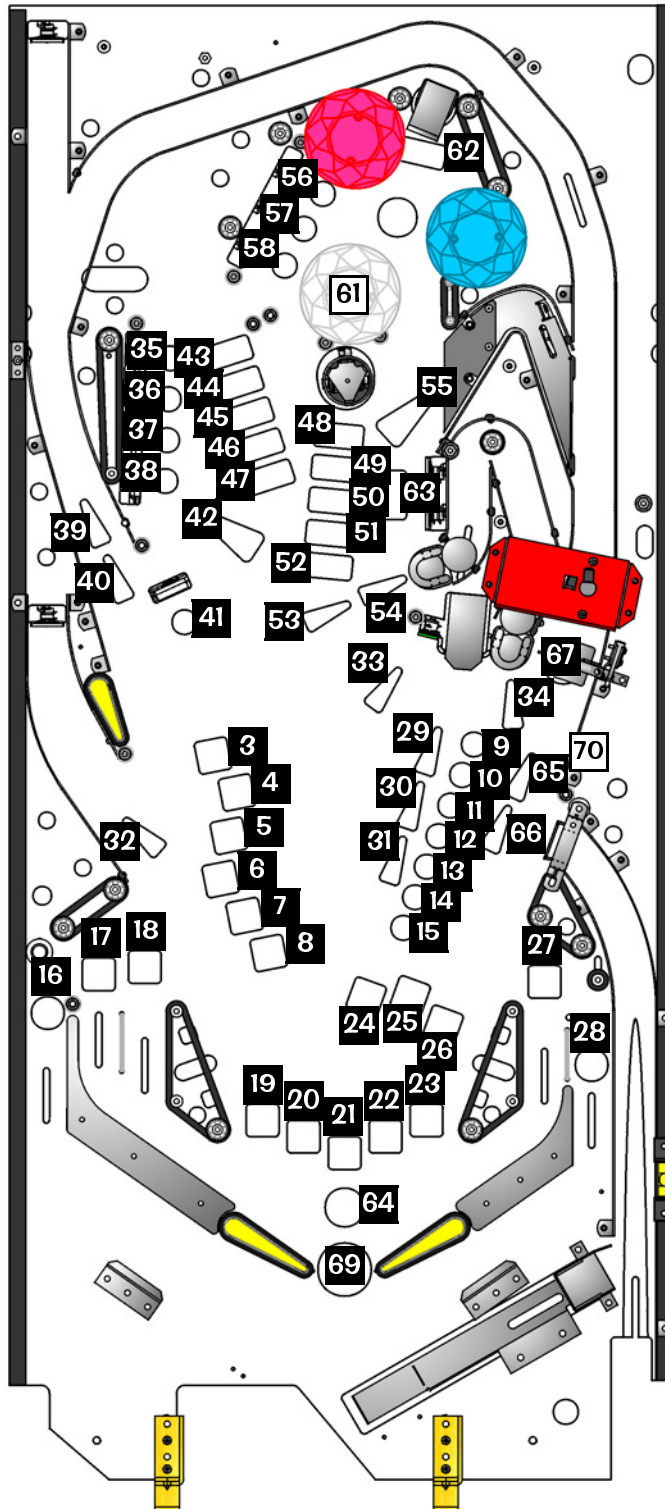

MINI-PLAYFIELD

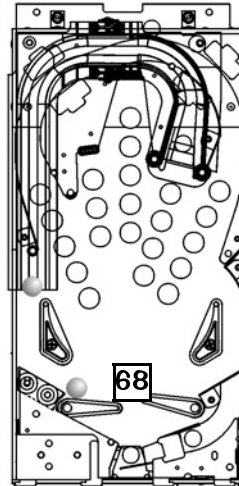

THE "LETTERS OF EACH NAME" LAMPS ARE NOT CONTROLLED LAMPS IN THE LAMP MATRIX.

SEE SECTION 5, PAGES 142-143 FOR LEDs ON THE LED PCB.

Typical Lamp Schematic & Wiring

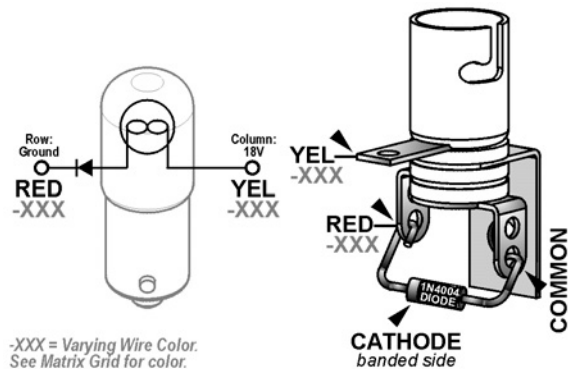

-XXX = Varying Wire Color. See Matrix Grid for color.

- = Lamps above Playfield.
- = Lamps below Playfield.

DOTS: diode n terminal strip, see Sec. 5, Chp. 2, Playfield Wiring.

Lamp Part Notes: #555 Wedge Base (W.B.) Bulb Clear = 165-5002-00. #44 Bayonet Bulb (Heavy Filament) Clear = 165-5000-44-HF.

See Section 4, Chapter 1, Parts Identification & Location, Pages 62-64 for more details on bulbs and corresponding sockets. Some Lamp Diodes may be located under the playfield, in the Cabinet



Find-It-In-Front:
Dr. Pinball



COILS DETAILED CHART TABLE

High Current Coils Group 1		Drive Transistor	Driver Output Board	Power Line Color	Power Line Connection	Power Voltage	Drive Transistor Control Line Color	D.T. Control Line Connect	Coil GA-Turn or Bulb Type
#1	TROUGH UP-KICKER	Q1	▲ I/O Power Driver ▼	YEL-VIO	J10-P9/10	50v DC	BRN-BLK	J8-P1	26-1200 ∪ 090-5044-ND
#2	AUTO LAUNCH	Q2		YEL-VIO	J10-P9/10	50v DC	BRN-RED	J8-P3	24-940 ∪ 090-5036-ND
#3	4-BANK DROP TARGET	Q3		YEL-VIO	J10-P9/10	50v DC	BRN-ORG	J8-P4	24-940 ∪ 090-5036-ND
#4	BALL SAVER DOWN (PINOCCHIO POST)	Q4		YEL-VIO	J10-P9/10	50v DC	BRN-YEL	J8-P5	32-1800 ∪ 090-5031-00-ND
#5	MERLIN EJECT (VUK)	Q5		YEL-VIO	J10-P9/10	50v DC	BRN-GRN	J8-P6	27-1500 ∪ 090-5004-ND
#6	1-BANK DROP TARGET	Q6		YEL-VIO	J10-P9/10	50v DC	BRN-BLU	J8-P7	24-940 ∪ 090-5036-ND
#7	LEFT SLINGSHOT	Q7		YEL-VIO	J10-P9/10	50v DC	BRN-VIO	J8-P8	27-1500 ∪ 090-5004-ND
#8	RIGHT SLINGSHOT	Q8		YEL-VIO	J10-P9/10	50v DC	BRN-GRY	J8-P9	27-1500 ∪ 090-5004-ND

High Current Coils Group 2		Drive Transistor	Driver Output Board	Power Line Color	Power Line Connection	Power Voltage	Drive Transistor Control Line Color	D.T. Control Line Connect	Coil GA-Turn or Bulb Type
#9	BOTTOM BUMPER	Q9	▲ I/O Power Driver ▼	YEL-VIO	J10-P9/10	50v DC	BLU-BRN	J9-P1	26-1200 ∪ 090-5044-ND
#10	RIGHT BUMPER	Q10		YEL-VIO	J10-P9/10	50v DC	BLU-RED	J9-P2	26-1200 ∪ 090-5044-ND
#11	TOP BUMPER	Q11		YEL-VIO	J10-P9/10	50v DC	BLU-ORG	J9-P4	26-1200 ∪ 090-5044-ND
#12	BALL SAVER UP (PINOCCHIO POST)	Q12		YEL-VIO	J10-P9/10	50v DC	BLU-YEL	J9-P5	26-1200 ∪ 090-5044-ND
#13	SWAMP EJECT (SCOOP)	Q13		YEL-VIO	J10-P9/10	50v DC	BLU-GRN	J9-P6	23-800 ∪ 090-5001-ND
#14	UPPER LEFT FLIPPER	Q14		BLU-YEL-3A Fuse-RED-YEL	J10-P6/7	50v DC	BLU-BLK	J9-P7	23-1500 ∪ 090-5062-ND
#15	LEFT FLIPPER (50v RED/YEL)	Q15		GRY-YEL-3A Fuse-RED-YEL	J10-P6/7	50v DC	ORG-GRY	J9-P8	23-1100 ∪ 090-5030-ND
#16	RIGHT FLIPPER (50v RED/YEL)	Q16		BLU-YEL-3A Fuse-RED-YEL	J10-P6/7	50v DC	ORG-VIO	J9-P9	23-1100 ∪ 090-5030-ND

Low Current Coils Group 1		Drive Transistor	Driver Output Board	Power Line Color	Power Line Connection	Power Voltage	Drive Transistor Control Line Color	D.T. Control Line Connect	Coil GA-Turn or Bulb Type
#17	LEFT MINI FLIPPER (UPR. P/F)	Q17	▲ I/O Power Driver ▼	BROWN	J7-P1	20v DC	VIO-BRN	J7-P2	27-950 ∪ 090-5046-01-ND
#18	RIGHT MINI FLIPPER (UPR. P/F)	Q18		BROWN	J7-P1	20v DC	VIO-RED	J7-P3	27-950 ∪ 090-5046-01-ND
#19	CASTLE GUARD (LEFT RAMP GATE)	Q19		BROWN	J7-P1	20v DC	VIO-ORG	J7-P4	32-1250 ∪ 515-6916-01-ND
#20	DONKEY MOTOR DRIVE	Q20		RED	J16-P4/8	5v DC	VIO-WHT	J7-P6	Strp. Motor 511-5043-00
#21	MINI TROUGH (SHOOTER UPR. P/F)	Q21		BROWN	J7-P1	20v DC	VIO-GRN	J7-P7	27-950 ∪ 090-5046-01-ND
#22	NOT USED	Q22					VIO-BLU	J7-P8	
#23	FLASH: LOWER LEFT	Q23		ORANGE	J6-P10	20v DC	VIO-BLK	J7-P9	#89 Bulb 165-5000-89
#24	OPTIONAL COIL	Q24		RED	J16-P4>8	5v DC	VIO-GRY	J7-P10	Opt. 5v

Diode On Terminal Strip (if noted)

Low Current Coils Group 2		Drive Transistor	Driver Output Board	Power Line Color	Power Line Connection	Power Voltage	Drive Transistor Control Line Color	D.T. Control Line Connect	Coil GA-Turn or Bulb Type
#25	FLASH: BACK(PANEL) LEFT	Q25	▲ I/O Power Driver ▼	ORANGE	J6-P10	20v DC	BLK-BRN	J6-P1	#89 Bulb 165-5000-89
#26	FLASH: BACK(PANEL) CENTER	Q26		ORANGE	J6-P10	20v DC	BLK-RED	J6-P2	#89 Bulb 165-5000-89
#27	FLASH: BACK(PANEL) RIGHT	Q27		ORANGE	J6-P10	20v DC	BLK-ORG	J6-P3	#89 Bulb 165-5000-89
#28	FLASH: (MAGIC) MIRROR	Q28		ORANGE	J6-P10	20v DC	BLK-YEL	J6-P4	#89 Bulb 165-5000-89
#29	FLASH: FIONA	Q29		ORANGE	J6-P10	20v DC	BLK-GRN	J6-P5	#89 Bulb 165-5000-89
#30	FLASH: RIGHT ORBIT (SPINNER)	Q30		ORANGE	J6-P10	20v DC	BLK-BLU	J6-P6	#89 Bulb 165-5000-89
#31	FLASH: POPS (BUMPERS)	Q31		ORANGE	J6-P10	20v DC	BLK-VIO	J6-P7	#89 Bulb 165-5000-89
#32	FLASH: LOWER RIGHT	Q32		ORANGE	J6-P10	20v DC	BLK-GRY	J6-P8	#89 Bulb 165-5000-89

Note: In Test Flash Lamps Menu ("Flash" Icon), Flashers tested are all Flash Lamps located between Q1-Q32 (This Game: **Q23, Q25-Q32**)

∪ Coil Note: ∪ -ND means 'No Diode'. -00B or -00T can be used for coil replacements, but the diode must be removed. Call for more info.





COIL & FLASH LAMP LOCATIONS

{Coils Detailed Chart Table [#1 - #32] on the prev. page}

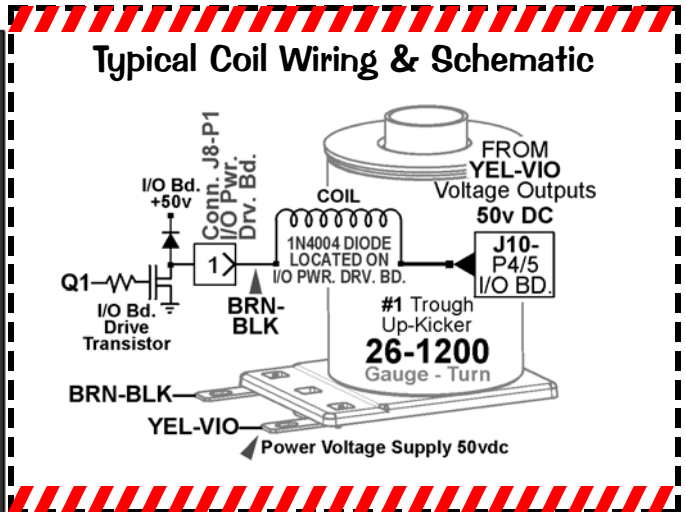
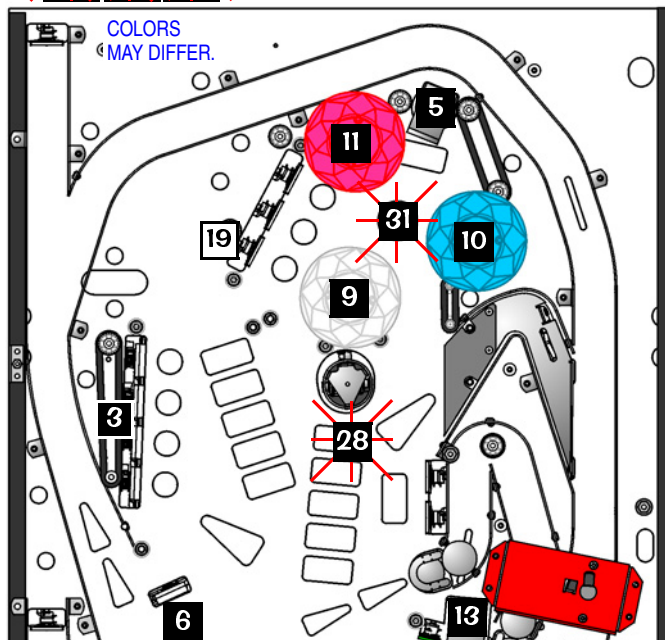
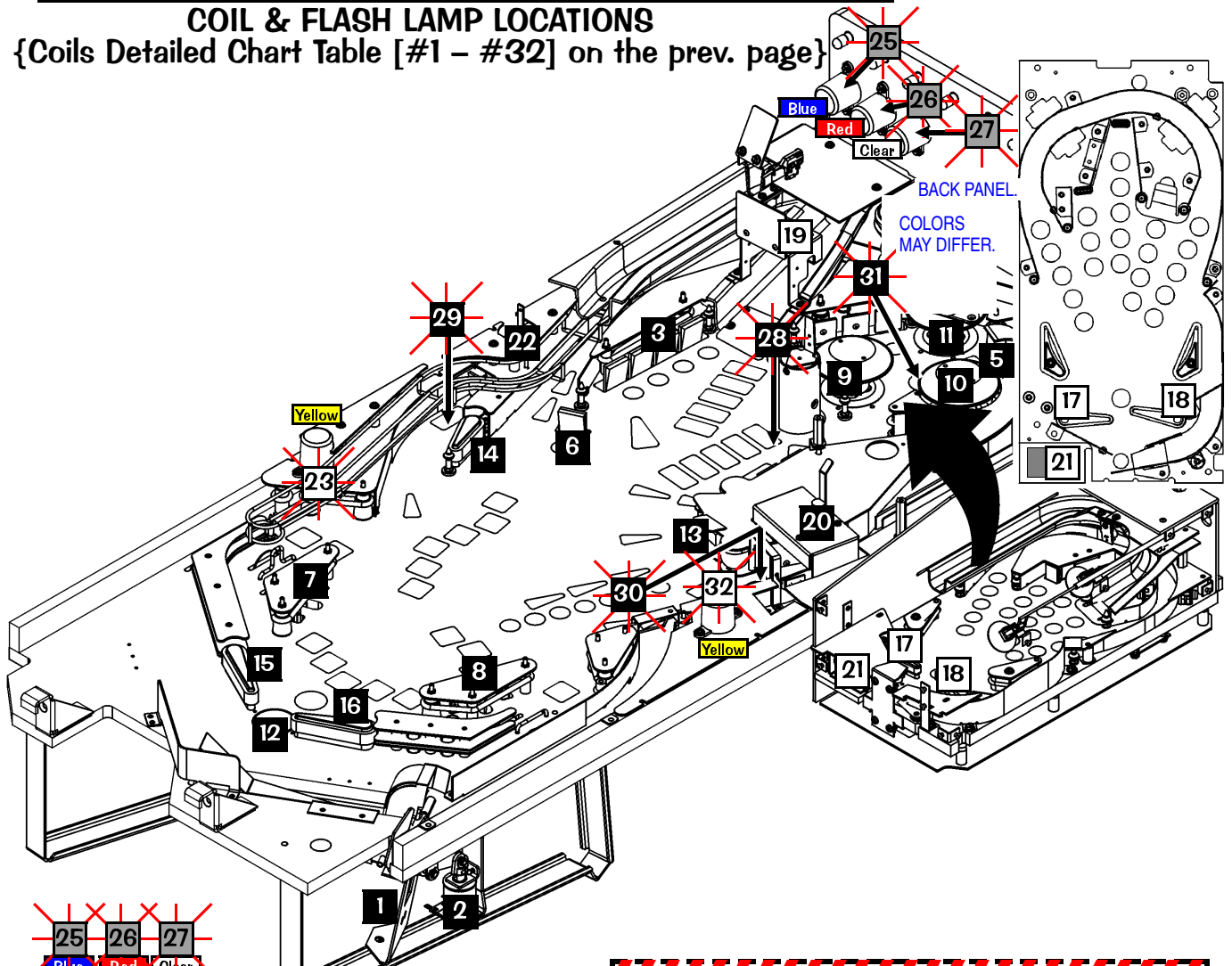

- = Coils / Flash Lamps above Playfield.
 - = Coils / Flash Lamps below Playfield.
 - = Coils / Flash Lamps on Back Panel.
 - = Color of Mini-Mars or Flash Lamp Bulb.
 - = Flash
- Coil Q24 is Optional. If either a Coin Meter, Token Dispenser or Knocker (all optional equipment) is required, call Technical Support for more information, 1-800-542-5377 or 1-708-345-7700.*



STANDARD ADJUSTMENT 1

GO TO ADJUSTMENTS MENU: STANDARD ADJUSTMENTS [#1 – #63]

Perform the below steps to review the adjustments. Enter the **SERVICE MENU**, then enter the **STANDARD ADJUSTMENTS MENU**. For adjustment definitions or summary, review Section 3, Chapter 4, **GO TO ADJUSTMENTS MENU**. See Section 3, Chapter 5, **GO TO INSTALLS MENU** (via the **UTILITIES MENU**), to easily change all adjustments required depending on the Install Type (Easy, Hard, 5-Ball, Home Play, etc.) desired.

Step 1 Press [**SELECT**]. Press [**BACK**] to exit or escape at any time.

Step 2 Press [**>**]. Go to the "ADJ" Icon. Press [**SELECT**].

Step 3 ... "S.P.I." Icon. Press [**SELECT**].



Step 4 **STANDARD ADJUSTMENT #1** appears with the Adjustment Name [**REPLAY TYPE**] flashing. With the Adjustment Name flashing, press [**<**] [**>**] to move between adjustments.

Step 5: To change the Adjustment Setting, press [**SELECT**]. With the Adjustment Setting flashing, press [**<**] [**>**] repeatedly until the desired setting appears. Press the [**SELECT**] to "install" the change. The Adjustment Comment (bottom text line) will indicate [**INSTALLED/FACTORY DEFAULT**], if the Factory Default Setting is selected or [**INSTALLED**] if the change is not the Factory Default Setting.

STANDARD ADJUSTMENTS [#1 – #63] ▼

Nr.	STANDARD ADJUSTMENT NAME	USA DEFAULT	YOUR SETTING
1	REPLAY TYPE	AUTO	
2	‡ REPLAY PERCENTAGE	10%	
3	‡ REPLAY AWARD	CREDIT	
4	‡ REPLAY LEVELS	1	
5	‡ AUTO REPLAY START	20,000,000	
6	‡ DYNAMIC REPLAY START	60,000,000	
7	‡ REPLAY LEVEL #1	15,000,000	
8	‡ REPLAY LEVEL #2	30,000,000	
9	‡ REPLAY LEVEL #3	45,000,000	
10	‡ REPLAY LEVEL #4	60,000,000	
11	‡ REPLAY BOOST	YES	
12	SPECIAL LIMIT	1	
13	‡ SPECIAL PERCENTAGE	10%	
14	SPECIAL AWARD	CREDIT	
15	FREE GAME LIMIT	5	
16	EXTRA BALL LIMIT	5	
17	‡ EXTRA BALL PERCENTAGE	25%	
18	GAME PRICING	USA 10	
19	MATCH PERCENTAGE	9%	
20	MATCH AWARD	CREDIT	
21	BALLS PER GAME	3	
22	TILT WARNINGS	2	
23	CREDIT LIMIT	30	
24	ALLOW HIGH SCORES	YES	
25	HIGH SCORE AWARD	CREDIT	
26	GRAND CHAMPION AWARDS	1	
27	HIGH SCORE #1 AWARDS	1	
28	HIGH SCORE #2 AWARDS	0	
29	HIGH SCORE #3 AWARDS	0	
30	HIGH SCORE #4 AWARDS	0	
31	GRAND CHAMPION SCORE	75,000,000	

Nr.	STANDARD ADJUSTMENT NAME	USA DEFAULT	YOUR SETTING
32	HIGH SCORE #1	55,000,000	
33	HIGH SCORE #2	40,000,000	
34	HIGH SCORE #3	30,000,000	
35	HIGH SCORE #4	25,000,000	
36	HSTD INITIALS	3 INITIALS	
37	HSTD RESET COUNT	2000	
38	FREE PLAY	NO	
39	LANGUAGE	ENGLISH	
40	PLAYER LANGUAGE SELECT	YES	
41	CUSTOM MESSAGE	ON	
42	FLASH LAMP POWER	NORMAL	
43	COIL PULSE POWER	NORMAL	
44	KNOCKER VOLUME	NORMAL	
45	GAME RESTART	YES	
46	BILL VALIDATOR	NO	
47	MUSIC VOLUME	1	
48	BALL SAVE TIME	0:05	
49	TIMED PLUNGER	OFF	
50	FLIPPER BALL LAUNCH	OFF	
51	COINDOOR BALL SAVER	NO	
52	COMPETITION MODE	NO	
53	CONSOLATION BALL	YES	
54	FAST BOOT	YES	
55	Q24 OPTION	COIN METER	
56	TICKET DISPENSER	NO	
57	PLAYER COMPETITION	YES	
58	TEAM SCORES	NO	
59	LOCATION ID	0	
60	GAME ID	0	
61	TIME FORMAT	12-HOUR	
62	COIN INPUT DELAY	30	
63	LOST BALL RECOVERY	YES	

Factory Defaults Settings are subject to change during production (especially Standard Adjustments 2, 4, 5, 13, 16-17, 19, 31-35 & 47).

‡ Not all Standard Adjustments are shown. Depending on the setting (whether Factory Default or if changed by the operator), associated adjustments do not appear, if not required. Note: If Game Dip Switch other than USA is installed, different Defaults will appear.





GO TO ADJUSTMENTS MENU: FEATURE ADJUSTMENTS [#1 – #26]

Perform the below steps to review the adjustments. Enter the **SERVICE MENU**, then enter the **FEATURE ADJUSTMENTS MENU**. For adjustment definitions or summary, review Section 3, Chapter 4, **GO TO ADJUSTMENTS MENU**. See Section 3, Chapter 5, **GO TO INSTALLS MENU** (via the **UTILITIES MENU**), to easily change all adjustments required depending on the Install Type (Easy, Hard, 5-Ball, Home Play, etc.) desired.

Step 1 Press [**SELECT**]. Press [**BACK**] to exit or escape at any time.

Step 2 Press [**>**]. Go to the "ADJ" Icon. Press [**SELECT**].

Step 3 Press [**>**]. Go to the "F.G." Icon. Press [**SELECT**].



Step 4 **FEATURE ADJUSTMENT #1** appears with the Adjustment Name [**ADULT CONTENT ENABLED**] flashing. With the Adjustment Name flashing, press [**<**] [**>**] to move between adjustments.

Step 5: To change the Adjustment Setting, press [**SELECT**]. With the Adjustment Setting flashing, press [**<**] [**>**] repeatedly until the desired setting appears. Press the [**SELECT**] to "install" the change. The Adjustment Comment (*bottom text line*) will indicate [**INSTALLED/FACTORY DEFAULT**], if the Factory Default Setting is selected or [**INSTALLED**] if the change is not the Factory Default Setting.

FEATURE ADJUSTMENTS [#1 – #26] ▼

Nr.	FEATURE ADJUSTMENT NAME	USA DEFAULT	YOUR SETTING	Nr.	FEATURE ADJUSTMENT NAME	USA DEFAULT	YOUR SETTING
1	ADULT CONTENT ENABLED	MODERATE		14	BURP MULTIBALL DIFFICULTY	MEDIUM	
2	POPS AT BALL START	1		15	PUSS IN BOOTS DIFFICULTY	MEDIUM	
3	PINBALL SPELLOUT DIFFICULTY	MEDIUM		16	SHOW MINI FLIPPERS	YES	
4	MINI CHARM LETTERS SPOTTED	0		17	POPS CARRYOVER	NO	
5	MINI MAN LETTERS SPOTTED	0		18	SWAMP DIFFICULTY	HARD	
6	MINI SHREK LETTERS SPOTTED	0		19	LEFT RAMP DIFFICULTY	MEDIUM	
7	MINI PUSS LETTERS SPOTTED	0		20	BALL SAVER POST TIME	9	
8	MINI FIONA LETTERS SPOTTED	0		21	PINOCCHIO MULTIBALLS	3	
9	MINI PLAYFIELD MIN. PLAY TIME	15		22	DISABLE BALL SAVER POST	NO	
10	MINI PLAYFIELD MAX PLAY TIME	30		23	DISABLE 4-BANK	NO	
11	MINI PF TIME DONKEY INCREMENT	1		24	DISABLE 1-BANK	NO	
12	LETTERS PER MINI PF SHOT	2		25	DISABLE MINI PLAYFIELD	NO	
13	MINI PLAYFIELD ENDING	SDN DEATH		26	SMART MINIPF ERROR CHECK	YES	

Factory Defaults Settings are subject to change during production

Note: If Game Dip Switch other than USA is installed, different Defaults will appear.



Find-It-In-Front:
Dr. Pinball





CHOOSE EARNINGS or STANDARD AUDITS

GO TO AUDITS MENU: EARNINGS AUDITS [#1 – #13] / STANDARD AUDITS [#1 – #59]

Perform the below steps to review the audits. Enter the **SERVICE MENU**, then enter the **EARNINGS AUDITS** or **STANDARD AUDITS** MENUS. For audit definitions or summary, review Section 3, Chapter 3, **GO TO AUDITS MENU**. Try the "DUMP AUDITS TO USB" Feature to create a text file of your audits. Don't forget to set the **DATE & TIME** in the **UTILITIES MENU**. See Section 3, Chapter 5, **GO TO UTILITIES MENU**, for more information.

Step 1 Press [**SELECT**].
Press [**BACK**] to exit or escape at any time.



Step 2 Press [**>**]. Go to the "AUD" Icon.
Press [**SELECT**].

EARNINGS AUDITS [#1 – #13] ▼

Step 3 Press [**>**]. Go to the "EARN" or "S.P.I." Icon.
Press [**SELECT**].

Nr.	EARNINGS AUDIT NAME	YOUR RESULT
1	TOTAL PAID CREDITS	
2	FREE GAME PERCENTAGE	
3	AVERAGE BALL TIME	
4	AVERAGE GAME TIME	
5	COINS THROUGH LEFT SLOT	
6	COINS THROUGH RIGHT SLOT	
7	COINS THROUGH CENTER SLOT	

Nr.	EARNINGS AUDIT NAME	YOUR RESULT
8	COINS THROUGH FOURTH SLOT	
9	COINS THROUGH FIFTH SLOT	
10	TOTAL COINS	
11	TOTAL EARNINGS	
12	METER CLICKS	
13	SOFTWARE METER	

Step 4 Press [**<**] [**>**] to move between audits.

STANDARD AUDITS [#1 – #59] ▼

Nr.	STANDARD AUDIT NAME	YOUR RESULT
1	TOTAL BALLS PLAYED	
2	TOTAL EXTRA BALLS	
3	EXTRA BALL PERCENTAGE	
4	REPLAY 1 AWARDS	
5	REPLAY 2 AWARDS	
6	REPLAY 3 AWARDS	
7	REPLAY 4 AWARDS	
8	TOTAL REPLAYS	
9	REPLAY PERCENTAGE	
10	TOTAL SPECIALS	
11	SPECIAL PERCENTAGE	
12	TOTAL MATCHES	
13	HIGH SCORE AWARDS	
14	HIGH SCORE PERCENT	
15	TOTAL FREE PLAYS	
16	TOTAL PLAYS	
17	0.0M – 1.99M SCORES	
18	2.0M – 3.99M SCORES	
19	4.0M – 5.99M SCORES	
20	6.0M – 7.99M SCORES	

Nr.	STANDARD AUDIT NAME	YOUR RESULT
21	8.0M – 9.99M SCORES	
22	10.0M – 12.49M SCORES	
23	12.5M – 14.99M SCORES	
24	15.0M – 17.49M SCORES	
25	17.5M – 19.99M SCORES	
26	20.0M – 24.99M SCORES	
27	25.0M – 29.99M SCORES	
28	30.0M – 39.99M SCORES	
29	40.0M – 49.99M SCORES	
30	50.0M – 74.99M SCORES	
31	75.0M – 99.99M SCORES	
32	100.0M – 149.99M SCORES	
33	150.0M+ SCORES	
34	AVERAGE SCORES	
35	SERVICE CREDITS	
36	BALL SEARCH STARTED	
37	LOST BALL FEEDS	
38	LOST BALL GAME STARTS	
39	LEFT DRAINS	
40	CENTER DRAINS	

Nr.	STANDARD AUDIT NAME	YOUR RESULT
41	RIGHT DRAINS	
42	TILTS	
43	TOTAL BALLS SAVED	
44	LEFT FLIPPER USED	
45	RIGHT FLIPPER USED	
46	0 – 1 MINUTE GAMES	
47	1 – 1.5 MINUTE GAMES	
48	1.5 – 2 MINUTE GAMES	
49	2 – 2.5 MINUTE GAMES	
50	2.5 – 3 MINUTE GAMES	
51	3 – 3.5 MINUTE GAMES	
52	3.5 – 4 MINUTE GAMES	
53	4 – 5 MINUTE GAMES	
54	5 – 6 MINUTE GAMES	
55	6 – 8 MINUTE GAMES	
56	8 – 10 MINUTE GAMES	
57	10 – 15 MINUTE GAMES	
58	15+ MINUTE GAMES	
59	RECENT REPLAY PERCENT	

Note: Audits are subject to change (with or without notice).



FEATURE AUDIT 1

GO TO AUDITS MENU: FEATURE AUDITS [#1 – #70]

Perform the below steps to review the audits. Enter the **SERVICE MENU**, then enter the **FEATURE AUDITS MENU**. Try the **"DUMP AUDITS TO USB"** Feature to create a text file of your audits. Don't forget to set the **DATE & TIME** in the **UTILITIES MENU**. See Section 3, Chapter 5, **GO TO UTILITIES MENU**, for more information.

Step 1 Press [**SELECT**]. Press [**BACK**] to exit or escape at any time.

Step 2 Press [**>**]. Go to the "AUD" Icon.
Press [**SELECT**].

Audit Number →
Audit Name →
Audit Result →



Step 3 Press [**>**]. Go to the "F.G." Icon. Press [**SELECT**].

Step 4 Press [**<**] [**>**] to move between audits.

FEATURE AUDITS [#1 – #70] ▼

Nr.	FEATURE AUDIT NAME	YOUR RESULT	Nr.	FEATURE AUDIT NAME	YOUR RESULT	Nr.	FEATURE AUDIT NAME	YOUR RESULT
1	LEFT OUTLANE		24	MINI FIONA COMPLETES		47	MYS. [MYSTERY] BIGGER POINTS	
2	RIGHT OUTLANE		25	MINI MAN COMPLETES		48	MYS. [MYSTERY] BONUS X	
3	GINGY RETURN LANE		26	MINI SHREK COMPLETES		49	MYS. [MYSTERY] SPOT CAST	
4	RAISE PINOCCHIO RETURN LANE		27	MINI KING COMPLETES		50	MYS. [MYSTERY] REPAY YOUR DEBT	
5	RIGHT RETURN LANE		28	MINI BOOTS COMPLETES		51	CAN (P.C.) RALLY THE VILLAINS	
6	FIONA SHOTS		29	DONKEY MULTIBALL STARTS		52	CAN (P.C.) 3 LITTLE PIGS	
7	PUSS IN BOOTS SHOTS		30	BURP MULTIBALL STARTS		53	CAN (P.C.) UN-HAPPY HOUR	
8	LEFT RAMP		31	REPAY YOUR DEBT STARTS		54	CAN (P.C.) ONCE UPON A TIME	
9	PINOCCHIO LIES TARGET		32	MYSTERY LIT		55	CAN (P.C.) DRAGON MULTIBALL	
10	4-BANK DROPS COMPLETED		33	MYSTERY COLLECTED		56	BUMP SHREK	
11	CASTLE GUARD TARGET		34	MYS. [MYSTERY] SPECIAL		57	BUMP KING	
12	PRINCE CHARMING SHOTS		35	MYS. [MYSTERY] EXTRA BALL		58	BUMP MAN	
13	MERLIN MYSTERY		36	MYS. [MYSTERY] POPS AT MAX		59	BUMP BOOTS	
14	UTURN SHOTS		37	MYS. [MYSTERY] EXTRA BALL		60	BUMP FIONA	
15	DONKEY SHOTS		38	MYS. [MYSTERY] START MBALL		61	BUMP DONKEY	
16	GINGY SHOTS		39	MYS. [MYSTERY] HOLD BONUS		62	SWAMP LIT	
17	SPINNERS		40	MYS. [MYSTERY] COLLECT BONUS		63	DATING GAME STARTS	
18	SWAMP HOLE		41	MYS. [MYSTERY] LIGHT SWAMP MODE		64	DINNER THEATRE STARTED	
19	LEFT NEWTON ROLL OVER		42	MYS. [MYSTERY] SUPER		65	WRESTLING MATCH STARTED	
20	RIGHT NEWTON ROLL OVER		43	MYS. [MYSTERY] PINOCCHIO		66	COOKIE CRUMBLES STARTED	
21	FAIRY GOD MOTHER TARGET		44	MYS. [MYSTERY] POST		67	OGRE'S ARE ONIONS STARTED	
22	DONKEY PINBALL STARTS		45	MYS. [MYSTERY] PINBALL		68	(LARD BOZO) SET LIGHT	
23	AVG. DONKEY PINBALL TIME		46	MYS. [MYSTERY] BIG POINTS		69	(LARD BOZO) STARTS	
						70	GAME POST 2MIN GAME	

Note: Audits are subject to change (with or without notice).



Find-It-In-Front:
Dr. Pinball



Domestic Pinball & Redemption Distributors Map

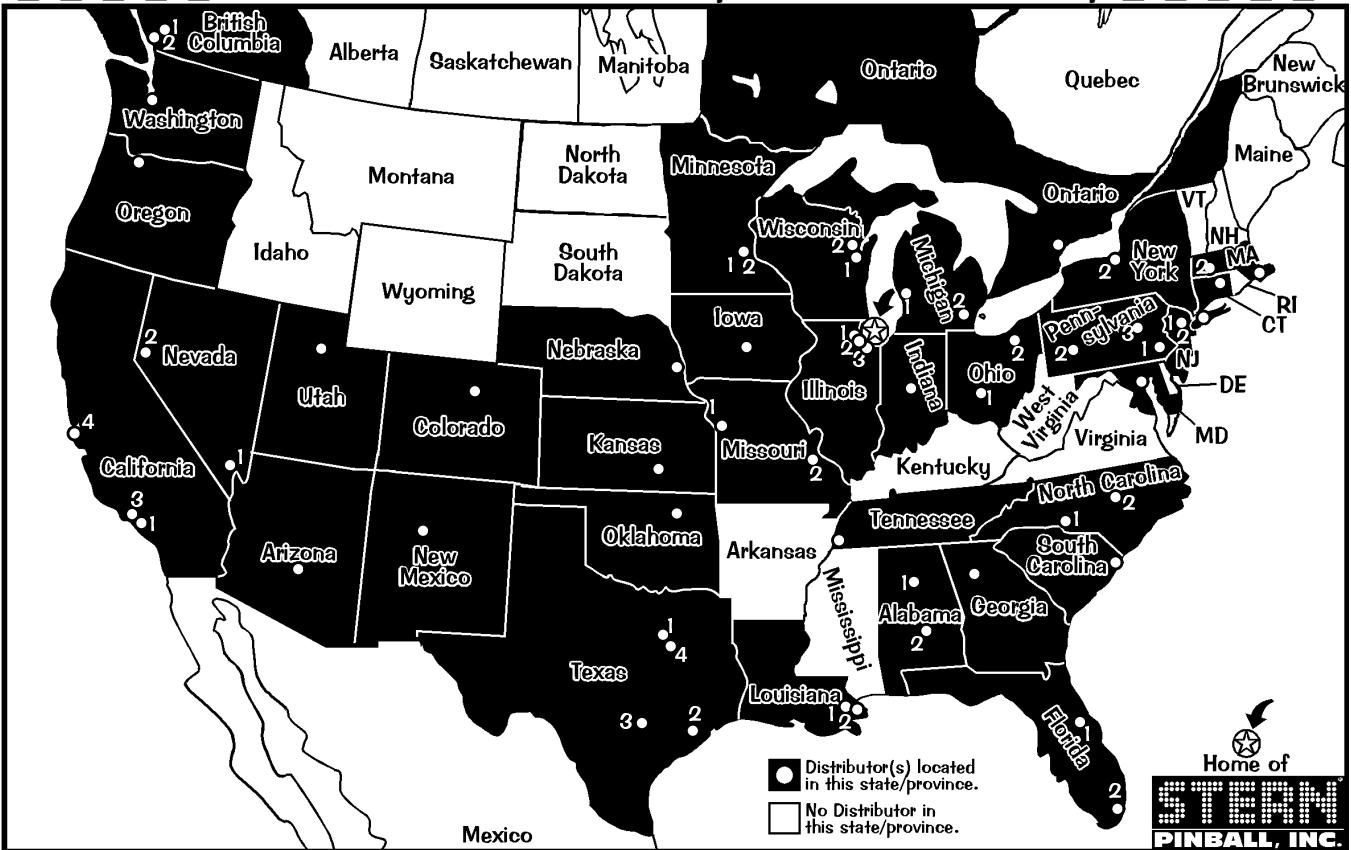

International Distributors Map

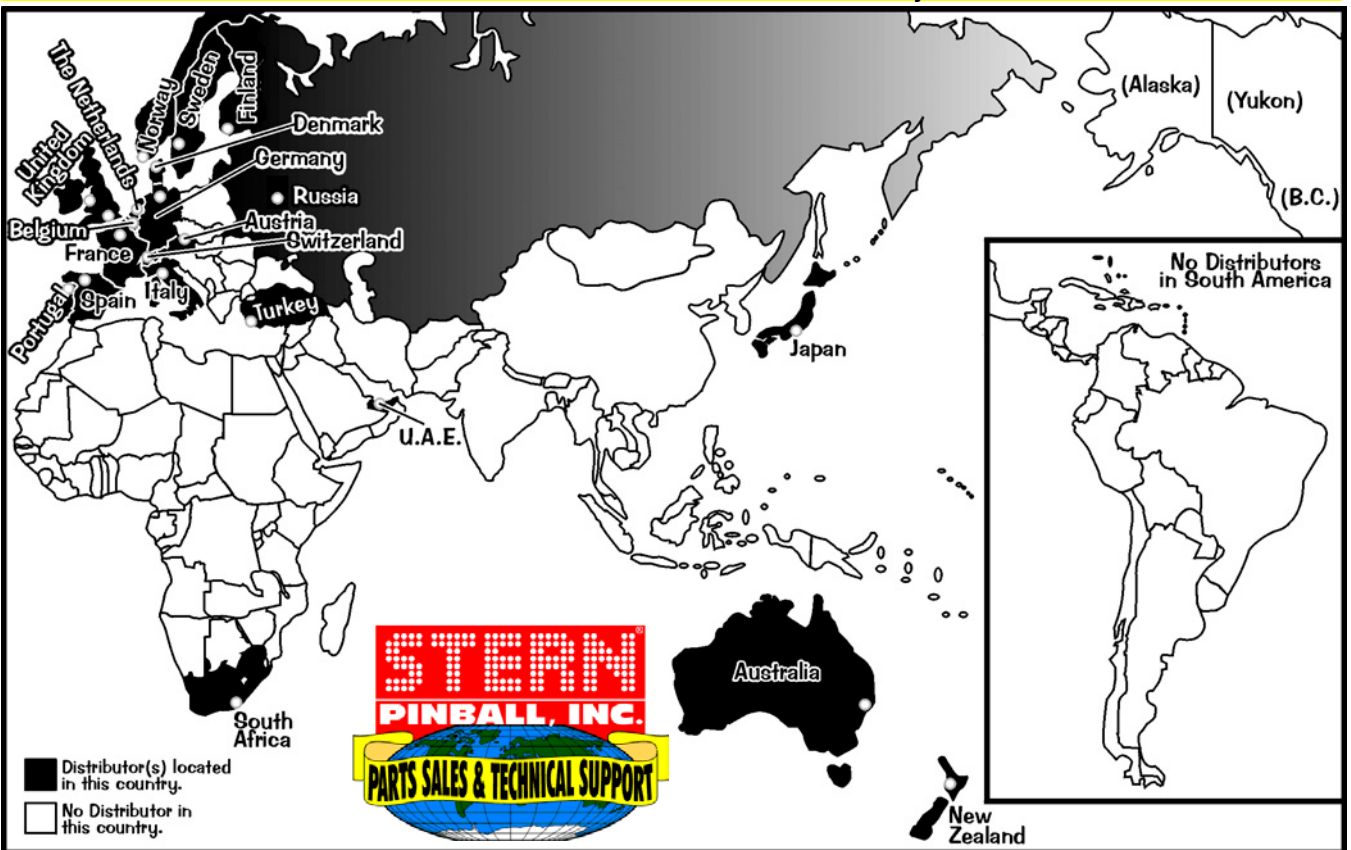

For *Parts & Service*, call your nearest Distributor. View the above maps & the directories on the next page to locate your closest Distributor in your state, province, or country. Distributors and phone numbers are subject to change. Call **Stern® Pinball, Inc. (Parts Sales & Technical Support)** with any questions or if your Distributor cannot help you: 1-800-542-5377 (in USA or Canada) or 1-708-786-5466. Visit us at www.SternPinball.com for current Distributor Information & other pinball needs.



Domestic Pinball & Redemption Distributors Directory

<p>ALABAMA Birmingham Vending Birmingham (1) 205-324-7526</p> <p>Franco Distributing Montgomery (2) 334-834-3455</p> <p>ARIZONA Betson West Phoenix 602-442-6630</p> <p>Mountain Coin Phoenix 602-269-7596</p> <p>CALIFORNIA Betson West Buena Park (1) 714-228-7500 So. San Francisco (2) 650-952-4220</p> <p>C.A. Robinson Los Angeles (3) 323-735-3001</p> <p>COLORADO Game Exchange of CO Denver 303-288-6500 (sales) 303-288-4300 (main)</p> <p>Mountain Coin Denver 303-427-2133</p> <p>CONNECTICUT TDM Distributing Williamantic 860-423-1403</p> <p>FLORIDA Birmingham Vending Orlando (1) 407-425-1505</p> <p>Brady Distributing Miami [Miramar] (2) 954-874-1100 Orlando (1) 407-872-1666</p> <p>GEORGIA Greater Southern Dist. Smyrna 770-803-3040</p> <p>ILLINOIS American Vending Sales Elk Grove Village (1) 847-439-9400</p> <p>Betson Midwest Bensenville (2) 630-238-9400</p>	<p>INDIANA Shaffer Distributing Indianapolis 317-899-2530</p> <p>IOWA Greater America Dist. Johnston 515-278-4455</p> <p>Moss Distributing Des Moines 515-266-6422</p> <p>KANSAS United Dist., Inc. Wichita 316-263-6181</p> <p>LOUISIANA AMA Distributors, Inc. Metairie (1) 504-835-3232</p> <p>New Orleans Novelty New Orleans (2) 504-888-3500</p> <p>MARYLAND Betson Enterprises Baltimore 410-646-4100</p> <p>Parts & Service Only: Weiner Distributing Baltimore 410-525-2600</p> <p>MASSACHUSETTS Betson Ent. (NECO) Norwood (1) 781-769-9760</p> <p>Gekay Sales Ludlow (2) 413-583-7700</p> <p>MICHIGAN Shaffer Distributing Livonia (2) 734-432-1040</p> <p>MINNESOTA Lieberman Companies Minneapolis (1) 800-879-0321 or 952-887-5299</p> <p>Moss Distributing Bloomington (2) 952-881-8770</p>	<p>MISSOURI Greater America Dist. Kansas City (1) 816-531-4300</p> <p>Moss Distributing Kansas City (1) 816-231-6600</p> <p>Shaffer Distributing St. Louis (2) 314-645-3393</p> <p>NEBRASKA Central Distributing Omaha 402-493-5600</p> <p>Greater America Dist. Omaha 402-553-2812</p> <p>NEVADA Mountain Coin Las Vegas (1) 702-798-0900</p> <p>Reno Game Sales Reno (2) 775-829-2080</p> <p>NEW JERSEY Betson Enterprises Carlstadt (1) 201-438-1300</p> <p>Jack Guarnieri Service Co., Inc. (Pinballsales.com) Lakewood (2) 800-473-5225 or 732-364-9900</p> <p>NEW MEXICO Mountain Coin Albuquerque 505-345-7706</p> <p>NEW YORK Betson Enterprises New Hyde Park (2) 516-354-4647 Syracuse (3) 315-437-2400</p> <p>Parts & Service Only: Bay Coin Richmond Hill (1) 718-291-5757</p>	<p>NORTH CAROLINA Brady Distributing Charlotte (1) 704-357-6284</p> <p>Parts & Service Only: Operators Distributing Archdale (2) 336-884-5714</p> <p>OHIO Shaffer Distributing Cincinnati (3) 800-282-0194 Columbus (1) 614-421-6800 Valley View (2) 216-447-1749</p> <p>OKLAHOMA Galaxy Distributing Tulsa 918-835-1166</p> <p>OREGON Mountain Coin Portland 503-234-5491</p> <p>Specialty Coin Products Portland 800-987-4946 or 503-786-9200</p> <p>PENNSYLVANIA Betson Enterprises King Of Prussia (1) 610-265-1155 Pittsburgh (2) 412-331-8703</p> <p>Superior Amusements Wilkes-Barre (3) 570-824-9994</p> <p>SOUTH CAROLINA Parts & Service Only: Green Coin Myrtle Beach 843-626-1900</p> <p>TENNESSEE Brady Distributing Memphis 901-345-7811</p> <p>Parts & Service Only: Green G.A.M.E.S. Memphis 901-353-1000</p>	<p>TEXAS Amusement Distributors San Antonio (3) 210-225-3844</p> <p>Betson Texas Dallas (1) 214-638-4900</p> <p>Discount Arcade Games Crowley (1) 817-297-0440</p> <p>H.A. Franz, & Co. Houston (2) 713-523-7366 San Antonio (3) 210-226-6322</p> <p>Master Sales Corsicana (4) 903-874-4740</p> <p>UTAH Mountain Coin Salt Lake City 801-262-5494</p> <p>Struve Distributing Salt Lake City 801-328-1636</p> <p>WASHINGTON Mountain Coin Auburn (Seattle) 253-736-6073</p> <p>WISCONSIN Pioneer Sales & Svc. Menomonee Falls (2) 262-781-1420</p> <p>Lieberman Companies Menomonee Falls (2) 800-236-1880 or 262-703-4168</p>	<p>CANADA</p> <p>ONTARIO Starburst Coin Mach. Toronto 416-251-2122</p> <p>BRITISH COLUMBIA Parts & Service Only: Can. Coin Machine Burnaby (1) 604-420-4008</p> <p>Parts & Service Only: Pacific Vending Vancouver (2) 604-324-2164</p>
--	---	--	--	--	---

Note: For states and Canadian Provinces which do not have Distributors, call the neighboring state or province with the city closest to you (indicated with a white dot). States or Provinces with more than 1 city containing a distributor are numbered. View the map on the previous page.

Note: From inside the US, use prefix 1-.

Note: Distributors are subject to change. Visit us at www.SternPinball.com for current Distributor Information.

International Distributors Directory

<p>AUSTRALIA Amusement Mach. Dist. Alexandria +61 (2) 9700 9600</p> <p>AUSTRIA R. Rupp Leibnitz +43 3 4528 6105</p> <p>BELGIUM NAMUSCO Bruxelles +32 2 414 4596</p> <p>DENMARK JK Automater A/S Thisted +45 97 92 0925</p> <p>ENGLAND see UNITED KINGDOM</p> <p>FINLAND Pelika net Oy Vantaa +358 9 290 450</p>	<p>FRANCE Avranches Automatic Saint Quentin sur le Homme +33 2 3389 6162</p> <p>SFA Paris +33 1 5326 8080</p> <p>GERMANY ADP Gauselmann GmbH Espelkamp +49 5741 27 32 85</p> <p>Crown Technologies GmbH Rellingen +49 4101 30 24 85</p> <p>Merkur Gaming GmbH Luebbecke +49 5772 4 94 22</p> <p>HOLLAND See The Netherlands</p>	<p>ITALY (RSM) Tecnoplay S.A. San Marino +39 549 901 508</p> <p>JAPAN HIC, Inc. Chiba-Ken +04 7176 4040</p> <p>THE NETHERLANDS GAME-XL B.V. Kruisstraat (Rosmalen) +31(0)73 522 2264</p> <p>NEW ZEALAND Coin Cascade Ltd. Christchurch +643 338 1411</p> <p>Parts & Service Only: Amco Machine Supplies Auckland +64 9846 7606</p>	<p>NORWAY Parts for Pinballs Sandefjord +47 9242 1402</p> <p>Vendomatic AS Skedsmokorset +47 2 291 8383</p> <p>PORTUGAL Jacinto & Martins, S.A. Belas +35 1214 3256 24 or +35 1214 3256 38</p> <p>RUSSIA Kalmancor Enterprise Ltd Moscow +95 124 5601 or +95 124 5613</p> <p>O.D.A. Game Machines Moscow +95 219 2949 or +95 219 8917</p> <p>SOUTH AMERICA See Betson Enterprises New Jersey, USA</p>	<p>SOUTH AFRICA K & W Amusements Port Elizabeth +27 41 484 3344 or +27 41 484 2940</p> <p>SPAIN Comercial Cocomatic Coslada (Madrid) +34 91 671 6980</p> <p>SWEDEN Bjuvia Fritid AB Bjuv +46 4238 6900</p> <p>SWITZERLAND Novomat, A.G. Harkingon +41 62 388 8961</p> <p>TAIWAN, R.O.C. SEC Taichung +886 4 229 10646</p>	<p>TURKEY Balo Marmaris +0 252 413 83 35</p> <p>UNITED ARAB EMIRATES Warehouse of Games Dubai +971 4 883 5880</p> <p>UNITED KINGDOM Electrocoin London, England +44 208 965 2055</p> <p>Parts & Service Only: Electrocoin Aftersales Cardiff, S. Glamorgan +44 292 045 0345</p>
---	---	---	---	--	---

Note: From inside the US, use prefix 011-.

From inside country listed, dial (0) first.



**Find-It-In-Front:
Dr. Pinball**



POWER REQUIREMENTS



This game **must be connected to a properly grounded outlet to reduce shock hazard** & insure proper game operation. See *Sec. 5, Schematics & Troubleshooting, Chp. 3, Cabinet Wiring (Transformer Power Wiring)*, for transformer connections required for **Normal, High, and Low Line** conditions.



Normal Line:		110v AC - 125v AC @ 60Hz		
Domestic use an 8AMP 250v Slo-Blo Fuse.	AVG OPERATION	CURRENT: 2.8AMP WATTAGE: 329w	MAX OPERATION CURRENT: 8AMP WATTAGE: 940w	
	High Line: use 2x 5AMP 250v Slo-Blo Fuses. (*England & Hong Kong use an 8AMP 250v S/B Fuse.)		218v AC - 240v AC @ 50Hz AVG OPERATION CURRENT: 1.8AMP WATTAGE: 412w	MAX OPERATION CURRENT: 5AMP 8AMP* WATTAGE: 1145w 1832w*
Low Line: Export Japan Only use an 8AMP 250v Slo-Blo Fuse.		95v AC - 108v AC @ 50Hz / 60Hz AVG OPERATION CURRENT: 2.6AMP WATTAGE: 264w		MAX OPERATION CURRENT: 8AMP WATTAGE: 812w

England & Hong Kong use an 8A Fuse.

TRANSPORTATION GAME DIMENSIONS

BEFORE TRANSPORTING



To reduce the possibility of damage, observe **ALL** precautions whenever transporting the game.

Read & follow Section 1, Chapter 1, Pinball Game Set-Up Procedures, and How to Secure the Backbox for Transporting. Remove the legs and secure the game within the transporting vehicle.

SAVE AND RETAIN ALL PRINTED INFORMATION INSIDE THE CABINET!

Shipping Box Dimensions

Height 56" Width 31"
 Depth 31"
 Approx. Unboxed Weight: 270lbs. (+/- 10)
 Boxed Weight: Wt. 290lbs. (+/- 5)

CAUTION

At least 2 people are required to move and maneuver this game. Use proper moving equipment & extreme care while handling!

TOURNAMENT SIGN +4³/₈"

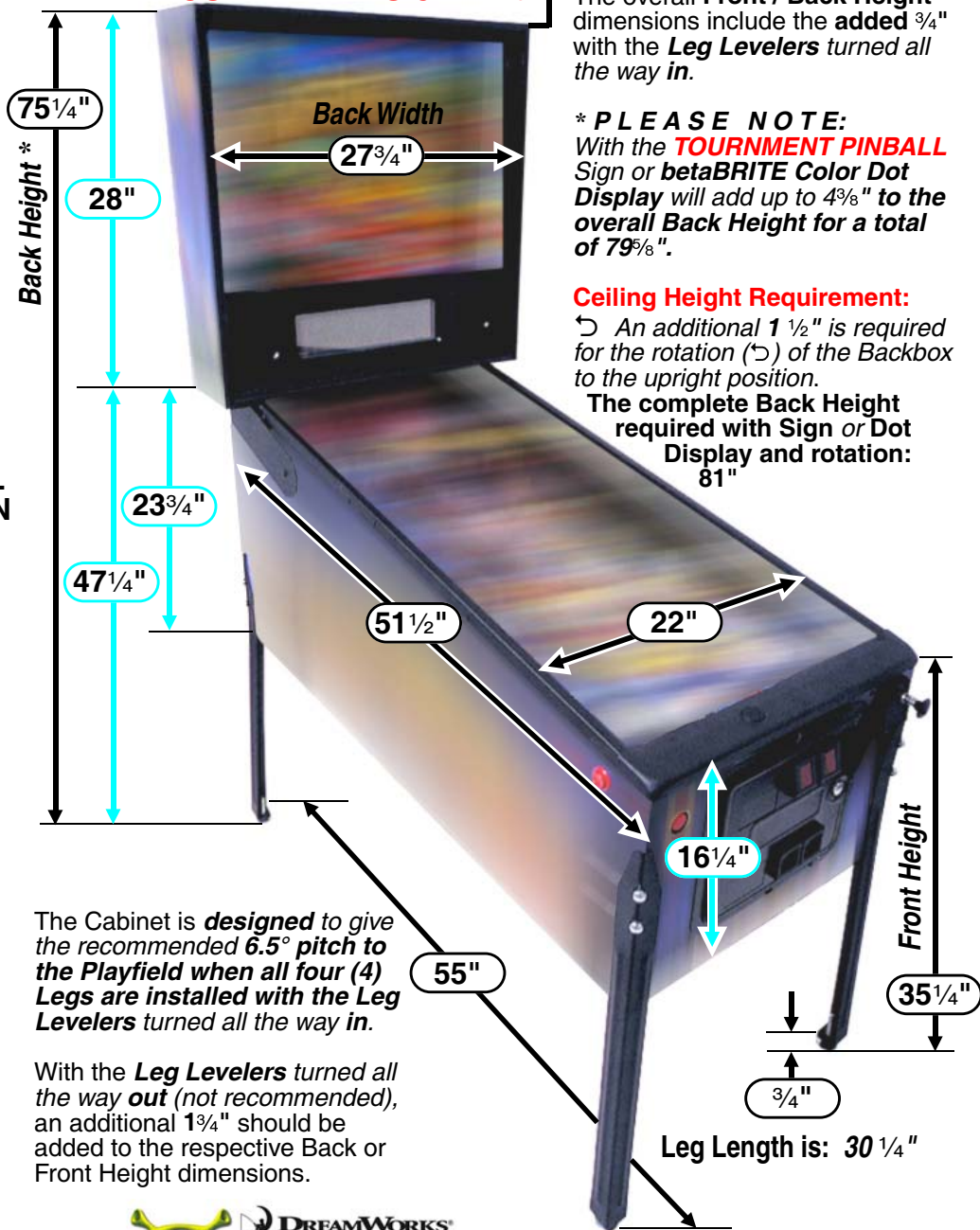

The overall **Front / Back Height** dimensions include the **added 3/4"** with the **Leg Levelers** turned all the way in.

*** PLEASE NOTE:** With the **TOURNAMENT PINBALL Sign** or **betaBRITE Color Dot Display** will add up to **4³/₈"** to the overall **Back Height** for a total of **79⁵/₈"**.

Ceiling Height Requirement:
 ↶ An additional **1 1/2"** is required for the rotation (↷) of the **Backbox** to the upright position.
The complete Back Height required with Sign or Dot Display and rotation: 81"

The Cabinet is **designed** to give the recommended **6.5° pitch** to the **Playfield** when all four (4) **Legs** are installed with the **Leg Levelers** turned all the way in.

With the **Leg Levelers** turned all the way **out** (not recommended), an additional **1³/₄"** should be added to the respective **Back** or **Front Height** dimensions.



Find-It-In-Front:
 Dr. Pinball

Shrek® Pinball

How To Update Your Game Code for the New S.A.M. System Inside Front

Find-It-In-Front: Dr. Pinball DR. 1 – 16

- ▶ For Proper Operation of this Pinball Game, (4) Pinballs must be installed in the Ball Trough! // Backbox Fuses, Cabinet Fuses, Playfield Fuses and Cabinet SwitchesDR. 1
- ▶ Find-It-In-Front: Dr. Pinball Section ExplainedDR. 2
 - ▷ Service Switch X4 Set Overview ▷ Functions in Game or Attract Mode ▷ Functions in the Service Menu
- ▶ Diagnostic AidsDR. 3
- ▶ CPU Dip Switch SettingsDR. 3
- ▶ Switch Matrix Grid (#1 – #64) and Dedicated Switches (D-1 – D-32).....DR. 4
- ▶ Switch LocationsDR. 5
- ▶ Lamp Matrix Grid (#1 – #80)DR. 6
- ▶ Lamp LocationsDR. 7
- ▶ Coils Detailed Chart TableDR. 8
- ▶ Coil & Flash Lamp LocationsDR. 9
- ▶ Go To Adjustments Menu: Standard Adjustments [#1 – #63].....DR. 10
- ▶ Go To Adjustments Menu: Feature Adjustments [#1 – #26]DR. 11
- ▶ Go To Audits Menu: Earnings Audits [#1 – #13] / Standard Audits [#1 – #59]DR. 12
- ▶ Go To Audits Menu: Feature Audits [#1 – #70]DR. 13
- ▶ Domestic Pinball & Redemption Distributors Map // International Distributors Map.....DR. 14
- ▶ Domestic Pinball & Redemption Distributors Directory // International Distributors Directory.....DR. 15
- ▶ Power Requirements // Transportation // Game DimensionsDR. 16

Sections 1-5, General Table of Contentsi – ii

Section 1, Chapter 1 of 1, After Set-Up1 – 4

- ▶ Pinball Game Set-Up Procedures1
 - ▷ Backbox (backglass removed): ▷ Playfield (glass removed): ▷ With the Coin Door Open:
- ▶ Pinball Game Set-Up Future Reference..... 1-3
- ▶ How to Secure the Backbox ... // Leg Leveler Adjustment // Easy Access Service System - 2 Positions4

Section 2, Chapter 1 of 1, Game Operation & Features5 – 6

- ▶ Start of Game Features5
 - ▷ Starting a Normal Game ▷ Starting Team Play (Doubles!) ▷ Starting Tournament Play
- ▶ During Game Features5
 - ▷ Feature Mode & Combination Shots ▷ Multiball ▷ Replay Feature
- ▶ End of Game Features5
 - ▷ Game Endings ▷ Match Feature ▷ Entering Initials/Name
- ▶ Auto Percentaging6
- ▶ Instruction Card.....6

Section 3, Chapter 1 of 6, Service Menu System 7 – 12

- ▶ Table of Contents for Section 3.....7

Section 3, Chapter 2 of 6, Go To Diagnostics Menu13 – 20

Section 3, Chapter 3 of 6, Go To Audits Menu21 – 24

Section 3, Chapter 4 of 6, Go To Adjustments Menu25 – 34

Section 3, Chapter 5 of 6, Go To Utilities Menu35 – 40

Section 3, Chapter 6 of 6, Go To Tournament Menu41 – 42

Section 4, Chapter 1 of 2, Parts Identification & Location (The Pink Pages)43 – 64

- ▶ Table of Contents for Section 4, Chapter 143

Section 4, Chapter 2 of 2, Drawings for Major Assemblies & Ramps (The Blue Pages)65 – 94

- ▶ Table of Contents for Section 4, Chapter 265

Section 5, Chapter 1 of 4, Backbox Wiring95 – 98

- ▶ Table of Contents for Section 5.....95

Section 5, Chapter 2 of 4, Playfield Wiring99 – 104

Section 5, Chapter 3 of 4, Cabinet and Coin Door Wiring105 – 108

Section 5, Chapter 4 of 4, Printed Circuit Boards (PCBs) 109 – 138

Appendixes A - J, Table of Contents End of Manual

- ▶ Stern Pinball, Inc. Limited Warranty // Cautions, Warnings & Notices last page





GLOSSARY OF TERMS

- A** Followed after a number means "Amp." or Ampage in an expression relating to an electrical object. (e.g. **8A**).
- AC** (Acronym) **A**lternating **C**urrent.
- Adj.** (Abbreviation) Adjustment(s).
- Assy.** (Abbreviation) Assembly.
- Au.** (Abbreviation) Audit(s).
- Bd.** (Abbreviation) Board.
- BOT** (Abbreviation) Bottom.
- Brkt.** (Abbreviation) Bracket.
- Bridge Rectifier** A configuration of a diode that allows current to flow in one direction producing both positive and negative pulsating DC Voltages.
- Color Coding** See Appendix H or I, Plastic Part Color Chart or Section 4, Chapter 1, Playfield - Plastic Posts & Spacers.
- Combination (Combo) [Shot]** Any variable pinball shot(s) made successively.
- Conn.** (Abbreviation) Connector.
- CMOS** Short for COSMOS (Complementary Symmetry M.O.S.); Complementary Metal-Oxide Semi-Conductor.
- CN** (Abbreviation) Connector (e.g. **CN5-P3**).
- CT** (Abbreviation) Center.
- DC** (Abbreviation) Direct Current.
- DT** (Abbreviation) Drop Target(s).
- DOTS** (Acronym) **D**iode **O**n **T**erminal **S**trip.
- EB** (Abbreviation) Extra Ball.
- Eject** Playfield surface device to kick ball back into play; Saucer.
- EPROM** (Acronym) **E**rasable **P**rogrammable **R**ead **O**nly **M**emory. Can be erased using UV Light and re-programmed.
- e.g.** (Abbreviation) Latin- Exempla gratia. For Example.
- EOS** (Acronym) **E**nd-**O**f-**S**troke (i.e. Switch for flipper).
- F** (Abbreviation) Fuse (i.e. **F23**).
- GA-Turn** Gauge & Turn describing the windings on a coil (e.g. **23-800**, **23** is the gauge of wire and **800** is the amount of windings).
- G.I.** (Abbreviation) General Illumination (Lamps).
- HWH** (Abbreviation) Hex Washer Head.
- IC** (Acronym) **I**ntegrated **C**ircuit (As in after 24-Pin IC).
- ID or I.D.** (Acronym) **I**nside **D**imension.
- i.e.** (Abbreviation) Latin- Id est. That is.
- IO or I/O** (Abbreviation) Input / Output (e.g. I/O Power Driver Bd.)
- LT, Lt. or L.** (Abbreviation) Left.
- Laser Kick** A coil/plunger used above the playfield to kick pinball back into play.
- LED** (Acronym) **L**ight **E**mitting **D**iode.
- Loop [Shot]** Continuously up a ramp and back to the flipper.
- Lwr.** (Abbreviation) Lower.
- Orbit [Shot]** From the left or right flipper around the back rail of the playfield back to the flipper.
- MB** (Abbreviation) Magnet Board.
- M-BALL or MBALL** (Abbreviation) Multiball™ More than 1 ball in game play.
- MID** (Abbreviation) Middle
- Non-Reflexive** See Reflexive.
- No. or N° or #** (Abbreviation) Number
- NPF** (Acronym) **N**o **P**roblem **F**ound.
- N.C. or NC** (Abbreviation) Normally Closed.
- N.O. or NO** (Abbreviation) Normally Open.
- NS** (Abbreviation) Not Stuffed. (Use in Part Listings, Sec. 5)
- OD or O.D.** (Abbreviation) Outside Dimension.
- P** (Abbreviation) Pin (e.g. **CN5-P3**).
- PCB** (Acronym) **P**rinted **C**ircuit **B**oard
- P/F** (Abbreviation) Playfield.
- PIA LED** (Acronym) **P**eripheral **I**nterface **A**dapter **L**ight **E**mitting **D**iode.. This is a diagnostic LED on the CPU; it should not be lit during normal operation of a pinball game.
- Plumb Bob Tilt** Weight on Tilt Assembly.
- PPH** (Abbreviation) Phillips Pan Head.
- Pop(s)** Another term for Turbo Bumper(s).
- PPB** (Acronym) Playfield Power Board ("Popcorn-Popping Bd.").
- PREV** (Abbreviation) Previous.
- PSB** (Abbreviation) Power Supply Board
- RAM** (Acronym) **R**andom **A**ccess **M**emory. **RAM** can store input instructions and supply output information.
- Reflexive/Non-Reflexive Reflexive**—Solenoid Drive Transistor is enabled directly by a switch closure on the (Relating to CPU Boards) solenoid assembly (Ver. 1/2).
- Non-Reflexive**—Solenoid Drive Transistor is enabled by the CPU after reading a switch closure in the Switch Matrix (Ver. 3). Also note: All CPU Boards are backwards compatible (e.g. Jurassic Park/Ver. 3 to Time Machine/ Ver. 2). Swapping a Ver. 2 Board to a Ver. 3 is not possible due to the special solenoids section (i.e. Slingshots, Turbo Bumpers, etc.) changing from **REFLEXIVE** to **NON-REFLEXIVE** on Ver. 3 Boards.
- Relay** An automatic switch operated by current in a coil.
- ROM** (Acronym) **R**ead **O**nly **M**emory. **ROM** cannot store input instructions but can supply output information. **ROM** can be programmed only once.
- RMA** (Abbreviation) Return Merchandise Authorization Number
- RT, Rt. or R.** (Abbreviation) Right; ("**R**" at the end of Target Assy. Part N° signifies Target Insert is Reversed.)
- RO** (Abbreviation) Rollover (switches).
- Saucer** See Eject.
- Scoop** A hole into the playfield. A metal scoop is in place to guide the ball into the kick-back under the playfield.
- Slam Tilt** A switch which closes when the game is slammed into or the Coin Door is slammed shut. Depending on adjustable settings, will cancel game in play when the number of closures required is achieved.
- SMB** (Abbreviation) Shaker Motor Board.
- Solenoid** A coil used for Electro Magnetic devices such as relays, flippers, slingshots, etc.
- SSFB** (Abbreviation) Solid State Flipper Board.
- STEP** Refers to the service switches on the coin door.
- Sub-Assy.** (Abbreviation) Sub-Assembly.
- S-U or S/U** (Abbreviation) Stand-Up (targets).
- TM** (Abbreviation) Trademark
- Transfer [Shot]** Maneuvering the ball in play from one flipper to the other. With flipper in the up position and the ball cradled by that flipper one would activate the flipper button in a quick repetitive manner to bounce the ball to the other side. Skilled players can rebound the ball off the slingshot.
- Tri-Ball** Three balls in play.
- TTL** (Abbreviation) Transistor-Transistor Logic
- Upr.** (Abbreviation) Upper.
- V or v** (Abbreviation) Volt(s).
- Ver.** (Abbreviation) Version.
- VUK** (Acronym) **V**ertical **U**p-**K**icker (Super or Standard).
- X** (Abbreviation) "Times" A multiplier; also used in dimensions.
- X-Ball** An undetermined number of ball(s) during game play.
- Zener Diode** A semi-conductor diode used for voltage regulation. Application depends on reverse break-down voltage.
- "-00B"** "B" at the end of Coil Part Numbers signifies that the diode is attached to the bottom of the lug.
- "-00T"** "T" at the end of Coil Part Numbers signifies that the diode is attached to the top of the lug (the side nearest the coil-winding).

STERN® PINBALL, INC. LIMITED WARRANTY

Stern® Pinball, Inc., ("seller") warrants only to the initial purchaser of its products that the items listed below are free from defects in material and workmanship under normal use and service for the **warranty period specified**:

Printed Circuit Boards PCBs (game logic): 2 months
Dot Matrix Display PCB: 9 months

No other parts of seller's product are warranted. Warranty periods are effective from the initial date of shipment from seller to its authorized distributors.

Seller's sole liability shall be, at its option, to repair or replace products which are returned to seller during the warranty periods specified, provided:

1. Seller is notified promptly upon discovery by purchaser that stated products are defective.
2. Such products are properly packaged and then returned freight prepaid, to seller's plant.

This warranty does not apply to any parts damaged during shipment and/or due to improper handling, or due to improper installation or usage, or alteration. In no event shall the seller be liable for any anticipated profits, loss of profits, loss of use, accidental or consequential damages or any other losses incurred by the customer in connection with the purchase of a Stern® Pinball, Inc. product.

WARRANTY DISCLAIMER

Except as specifically provided in a written contract between seller and purchaser, there are no other warranties, express or implied, including any implied warranties of merchantability or fitness for a particular purpose.

CAUTIONS, WARNINGS & NOTICES

CAUTION

 For safety and reliability, substitute parts and equipment modifications are not recommended (*and may void any warranties*). Use of non-Stern® Pinball Inc. parts or modifications of game circuitry, may adversely affect game play, or may cause injuries. Transport pinball games with hinged backbox in the down position only! Always take great care when servicing any game. Always read the service manual before replacing or servicing components. **SUBSTITUTIONS OF PARTS OR EQUIPMENT MODIFICATIONS** may void FCC Type acceptance.

 **Always disconnect the line voltage before servicing. Some parts may still hold current when unplugged.**

WARNING

 This equipment generates, uses, and can radiate radio frequency energy, and if not installed and used in accordance with the instructions manual, may cause interference to radio communications. It has been tested and found to comply with the limits for a class a computing device pursuant to SUBPART J OF PART 15 OF FCC RULES, which are designed to provide reasonable protection against such interference when operated in a commercial environment. Operation of this equipment in a residential area is likely to cause interference in which case the user at his own expense will be required to take whatever measures may be required to correct the interference.

RF INTERFERENCE NOTICE: Cable harness placements and ground strap routing on this game have been designed to keep RF radiation and conduction within levels accepted by the FCC rules. To maintain these levels, reposition harnesses and reconnect ground straps to their original placements, if they become disconnected during maintenance.

 (a) "The appliance has to be placed in a horizontal position."
(b) "This appliance is not to be cleaned by a *Water Jet*."

 **603335-7.12.1 (i)** "Do not locate this appliance in an area where a *Water Jet* is used." **(ii)** "Do not clean this appliance with a *Water Jet*." **60335-7.12.5 (b)** If the supply cord is damaged, it must be replaced by the manufacturer, its service agent or similarly qualified persons in order to avoid a hazard.

NOTICES

THIS DOCUMENT AND THE DATA DISCLOSED HEREIN OR HERewith IS NOT TO BE REPRODUCED (EXCEPT WHERE NOTED), USED OR OTHERWISE DISCLOSED IN WHOLE OR IN PART TO ANYONE WITHOUT WRITTEN CONSENT OF STERN® PINBALL, INC. **WARNING:** PRODUCTS IN THIS MANUAL, THE COMPANY NAME AND DEVICES AND THE DESIGN OF THE MANUAL ITSELF, ARE PROTECTED BY FEDERAL PATENTS (*AND PATENTS PENDING*), DESIGN REGISTRATIONS, TRADEMARKS AND COPYRIGHTS. ACTION WILL BE TAKEN IN THE EVENT OF INFRINGEMENT OR IMITATION. THE RIGHT IS RESERVED TO CHANGE SPECIFICATIONS WITHOUT PRIOR NOTICE.

© 2008 Manufactured by Stern® Pinball, Inc. Icon Designs, ToPS™ Logo, Bump N' Win™ Logo & all related indicia are trademarks of Stern® Pinball, Inc. All Rights Reserved. Manufactured in the USA.

"Multiball" is a registered trademark of Williams Electronics Games, Inc. Used by permission.

PCB Schematics (Section 5, Chapter 4) ©1995-2008 by CES (Creative Electronics & Software, Inc.) where noted.

If optional BETAbrite is purchased: Copyright ©2008. BETA-brite and logo are trademarks of Adaptive Micro Systems, Inc. registered in the USA Patent and Trade-mark Office. All Rights Reserved.

Shrek®, Ears, Shrek "S" and all related characters TM & ©2008 DreamWorks L.L.C., Shrek Evergreen TM & ©2008 DreamWorks Animation L.L.C. Stern Pinball, Inc. All Rights Reserved. "ALL STAR" (Gregory Camp) ©1999 Warner-Tamerlane Publishing Corp. (BMI) and Squish Moth Music (BMI) all rights administered by Warner-Tamerlane Publishing Corp. All Rights Reserved. Used by permission. "ALL STAR" performed by Smash Mouth (P)1999, Interscope Records Courtesy of Interscope Records under license from Universal Music Enterprises. Music from SHREK, Written by Harry Gregson-Williams and John Powell, Courtesy of DreamWorks Animation L.L.C.



SWITCH MATRIX GRID [#1 - #64] {Switch Locations on the next page}

CPU/Sound Board	01	02	03	04	05	06	07	08	09	10	11	12	13	14	15	16
	IC-U22A RETURN▲ WHT-BRN J6-P9	IC-U22B RETURN▲ WHT-RED J6-P8	IC-U22C RETURN▲ WHT-ORG J6-P7	IC-U22D RETURN▲ WHT-YEL J6-P6	IC-U16A RETURN▲ WHT-GRN J6-P5	IC-U16B RETURN▲ WHT-BLU J6-P3	IC-U16C RETURN▲ WHT-VIO J6-P2	IC-U16D RETURN▲ WHT-GRY J6-P1	IC-U36A RETURN▲ TAN-BLK J12-P9	IC-U36B RETURN▲ TAN-RED J12-P8	IC-U36C RETURN▲ TAN-ORG J12-P7	IC-U36D RETURN▲ TAN-YEL J12-P6	IC-U40A RETURN▲ TAN-GRN J12-P4	IC-U40B RETURN▲ TAN-BLU J12-P3	IC-U40C RETURN▲ TAN-VIO J12-P2	IC-U40D RETURN▲ TAN-WHT J12-P1
01 Q1 DRIVE ▶ GRN-BRN J1-P1	SW. #1 BALL SAVER UP 180-5010-04 below playfield	SW. #2 BALL SAVER DOWN 180-5010-04 below playfield	SW. #3 LEFT ORBIT STAND-UP 515-5162-08 below playfield	SW. #4 RIGHT 2-BANK BOTTOM 515-5162-08 below playfield	SW. #5 RIGHT 2-BANK TOP 515-5162-08 below playfield	SW. #6 LEFT NEWTON ROLLER 500-6227-01 below playfield	SW. #7 RIGHT NEWTON ROLLER 500-6227-02 below playfield	SW. #8 GODMOTHER (S-UP) TARGET 515-5967-04 below playfield	SW. #9 1-BANK DROP TARGET 520-5252-01 below playfield	SW. #10 FIONA (STAND-UP) TARGET 515-5162-08 below playfield	SW. #11 NOT USED	SW. #12 NOT USED	SW. #13 SWAMP EJECT 180-5183-00 1 per Asm. D.O.T.S.	SW. #14 NOT USED	SW. #15 TOURNAMENT START 180-5119-03 Front Molding CABINET	SW. #16 START BUTTON 180-5174-00 In Cabinet CABINET
02 Q2 DRIVE ▶ GRN-RED J1-P3	SW. #17 NOT USED	SW. #18 (4-BALL) TROUGH #4 (L) 180-5119-02 below playfield	SW. #19 (4-BALL) TROUGH #3 180-5119-02 below playfield	SW. #20 (4-BALL) TROUGH #2 180-5119-02 below playfield	SW. #21 (VUK OPTO) TROUGH #1 (R) TRANS./REC. TX 515-0173-00 RX 515-0174-00 below playfield	SW. #22 (STACK OPTO) TROUGH JAM 180-5157-00 below playfield	SW. #23 SHOOTER LANE 500-6227-02 below playfield	SW. #24 LEFT OUTLANE 500-6227-02 below playfield	SW. #25 LEFT RETURN [LANE] 500-6227-02 below playfield	SW. #26 LEFT SLING 180-5054-00 2 per Asm.	SW. #27 RIGHT SLING 180-5054-00 2 per Asm.	SW. #28 RIGHT RETURN [LANE] 500-6227-01 below playfield	SW. #29 RIGHT OUTLANE 500-6227-01 below playfield	SW. #30 TOP BUMPER 180-5015-04 below playfield	SW. #31 RIGHT BUMPER 180-5015-04 below playfield	SW. #32 BOTTOM BUMPER 180-5015-04 below playfield
03 Q3 DRIVE ▶ GRN-ORG J1-P4	SW. #33 LEFT RAMP MADE 180-5087-00 20 pin playfield	SW. #34 NOT USED	SW. #35 CASTLE GUARD 180-5119-02 above playfield	SW. #36 NOT USED	SW. #37 NOT USED	SW. #38 NOT USED	SW. #39 RIGHT ORBIT SPINNER 180-5010-04 above playfield	SW. #40 PINOCCHIO RETURN [INNER RT.] 500-6227-02 below playfield	SW. #41 3 BANK (STAND-UP) BOTTOM 515-5162-08 below playfield	SW. #42 3 BANK (STAND-UP) MIDDLE 515-5162-08 below playfield	SW. #43 3 BANK (STAND-UP) TOP 515-5162-08 below playfield	SW. #44 BABY 4 (BOT) [4-BANK] 520-5252-04 below playfield	SW. #45 BABY 3 [4-BANK] 520-5252-04 below playfield	SW. #46 BABY 2 [4-BANK] 520-5252-04 below playfield	SW. #47 BABY 1 (TOP) [4-BANK] 520-5252-04 below playfield	SW. #48 SNEAK RAMP 180-5183-00 below playfield
04 Q4 DRIVE ▶ GRN-YEL J1-P5	SW. #49 MAGIC MIRROR (CAN) 180-5189-00 3 pin playfield	SW. #50 MINI MAIN TARGET [STAND-UP] 500-7098-00 below mini-of	SW. #51 MINI SHREK TARGET [STAND-UP] 180-5098-00 below mini-of	SW. #52 MINI RIGHT ORBIT 500-6775-00 mini-playfield	SW. #53 MINI LEFT ORBIT 500-6775-00 mini-playfield	SW. #54 MINI RAMP 500-6775-01 mini-playfield	SW. #55 MINI TROUGH 500-6775-01 mini-playfield	SW. #56 NOT USED	SW. #57 RIGHT ORBIT 500-6227-02 below playfield	SW. #58 NOT USED	SW. #59 NOT USED	SW. #60 NOT USED	SW. #61 NOT USED	SW. #62 NOT USED	SW. #63 NOT USED	SW. #64 MERLIN EJECT 180-5209-00 below playfield D.O.T.S.

Wire Color Abbreviations used: **BLK** Black, **BLU** Blue, **BRN** Brown, **GRY** Gray, **GRN** Green, **LGN** Light Grn., **ORG** Orange, **PNK** Pink, **RED** Red, **TAN** Tan, **VIO** Violet, **WHT** White, **YEL** Yellow

Dedicated Switches (D-1 - D-32) {Dedicated Switch Locations on the next page}

CPU/SND Board	IC-U2 PNK-BRN J2-P2	IC-U2 PNK-RED J2-P3	IC-U2 PNK-ORG J2-P4	IC-U2 PNK-YEL J2-P6	IC-U2 PNK-GRN J2-P7	IC-U2 PNK-BLU J2-P8	IC-U2 PNK-VIO J2-P9	IC-U2 PNK-GRY J2-P10	IC-U4 GRY-BRN J3-P1	IC-U4 GRY-RED J3-P2	IC-U4 GRY-ORG J3-P3	IC-U4 GRY-YEL J3-P5	IC-U4 GRY-GRN J3-P6	IC-U4 GRY-BLU J3-P7	IC-U4 GRY-VIO J3-P8	IC-U4 GRY-BLK J3-P9
GROUND (BLK) J2-P11 & J3-P10	SW. D-1 LEFT COIN SLOT 180-5204-00 Coin Door	SW. D-2 CENTER COIN SLOT/DBA 180-5204-00 Coin Door	SW. D-3 RIGHT COIN SLOT 180-5204-00 Coin Door	SW. D-4 4TH COIN SLOT 180-5204-00 Coin Door	SW. D-5 5TH COIN SLOT IF USED	SW. D-6 NOT USED	SW. D-7 NOT USED	SW. D-8 NOT USED	SW. D-9 LEFT FLIPPER BUTTON 180-5164-01 Cabinet Side	SW. D-10 LEFT FLIPPER E.O.S. 180-5149-00 Flipper Asm.	SW. D-11 RIGHT FLIPPER BUTTON 180-5160-01 Cabinet Side	SW. D-12 RIGHT FLIPPER E.O.S. 180-5149-00 Flipper Asm.	SW. D-13 UPR. LT. FLIPPER BUTTON 180-5164-01 Cabinet Side	SW. D-14 NOT USED	SW. D-15 UPR. RT. FLIPPER BUTTON 180-5164-01 Cabinet Side	SW. D-16 NOT USED

CPU/SND Board	IC-41 LGN-BRN J13-P1	IC-41 LGN-RED J13-P3	IC-41 LGN-ORG J13-P4	IC-41 LGN-YEL J13-P5	IC-41 LGN-BLK J13-P6	IC-41 LGN-BLU J13-P7	IC-41 LGN-VIO J13-P8	IC-41 LGN-GRY J13-P9								
GROUND (BLK) J13-P10	SW. D-17 TILT PENDULUM (PLUMB BOB) See Sec. 4, Chp. 1, Pg. 63 for cab. parts	SW. D-18 SLAM TILT OPTIONAL 502-5032-00 Optional Kit	SW. D-19 TICKET NOTCH NOTIFIED BELOW P/F	SW. D-20 NOT USED	SW. D-21 BACK (GREEN BUTTON) 180-5192-04 Coin Door	SW. D-22 MINUS (-) / RED BUTTON 180-5192-02 Coin Door	SW. D-23 PLUS (+) / RED BUTTON 180-5192-02 Coin Door	SW. D-24 SELECT (BLACK BUTTON) 180-5192-00 Coin Door	SW. D-25 DIP SWITCH POSITION #1 ON / OFF	SW. D-26 DIP SWITCH POSITION #2 ON / OFF	SW. D-27 DIP SWITCH POSITION #3 ON / OFF	SW. D-28 DIP SWITCH POSITION #4 ON / OFF	SW. D-29 DIP SWITCH POSITION #5 ON / OFF	SW. D-30 DIP SWITCH POSITION #6 ON / OFF	SW. D-31 DIP SWITCH POSITION #7 ON / OFF	SW. D-32 DIP SWITCH POSITION #8 ON / OFF

CPU/SOUND BD. SW1 DIP SWITCH (located between Connectors J3/J13)

FULL SIZE MATRICES: FIND-IT-IN-FRONT (DR. 4 & DR. 6)

LAMP MATRIX GRID [#1 - #80] {Lamp Locations on the next page}

I/O Power Driver Board	IC-U17 18VDC YEL-BRN J13-P9	IC-U16 18VDC YEL-RED J13-P6	IC-U15 18VDC YEL-ORG J13-P7	IC-U14 18VDC YEL-BLK J13-P6	IC-U13 18VDC YEL-GRN J13-P5	IC-U12 18VDC YEL-BLU J13-P4	IC-U11 18VDC YEL-VIO J13-P3	IC-U10 18VDC YEL-GRY J13-P1
01 Q33 GROUND RED-BRN J12-P1	LP. #1 START BUTTON 165-5002-00	LP. #2 TOURNAMENT START BUTTON 165-5103-00	LP. #3 SHREK 165-5002-00	LP. #4 FIONA 165-5000-44-HF	LP. #5 PUSS IN BOOTS 165-5000-44-HF	LP. #6 GINGY 165-5000-44-HF	LP. #7 PRINCE CHARMING 165-5000-44-HF	LP. #8 DONKEY 165-5000-44-HF
02 Q34 GROUND RED-BLK J12-P2	LP. #9 (P) INBALL 165-5002-00	LP. #10 P (I) NBALL 165-5000-44-HF	LP. #11 PI (N) BALL 165-5000-44-HF	LP. #12 PIN (B) ALL 165-5000-44-HF	LP. #13 PINB (A) LL 165-5000-44-HF	LP. #14 PINBAL (L) L 165-5000-44-HF	LP. #15 PINBAL (L) 165-5000-44-HF	LP. #16 LEFT OUTLANE [EXTRA BALL] 165-5000-44-HF
03 Q35 GROUND RED-ORG J12-P3	LP. #17 LEFT RETURN [2X GINGY] 165-5002-00	LP. #18 TELL A LIE [LEFT INNER] 165-5000-44-HF	LP. #19 BRIDGE TO FIONA 165-5000-44-HF	LP. #20 DINNER THEATRE 165-5000-44-HF	LP. #21 WRESTLING MATCH 165-5000-44-HF	LP. #22 COOKIE CRUMBLES 165-5000-44-HF	LP. #23 OGRES ARE ONIONS 165-5000-44-HF	LP. #24 (1) [BY RT. SLING] 165-5000-44-HF
04 Q36 GROUND RED-YEL J12-P4	LP. #25 [BY RT. SLING] (2) 165-5002-00	LP. #26 [BY RT. SLING] (3) 165-5000-44-HF	LP. #27 RT RETURN [2X FIONA] 165-5000-44-HF	LP. #28 RT. OUTLANE [SPECIAL] 165-5000-44-HF	LP. #29 SWAMP [SCOOP] 165-5000-44-HF	LP. #30 PINBALL [SCOOP] 165-5000-44-HF	LP. #31 MULTIBALL [SCOOP] 165-5000-44-HF	LP. #32 FIONA JACKPOT 165-5000-44-HF
05 Q37 GROUND RED-GRN J12-P5	LP. #33 FAIRY GOD-MOTHER [STD-UP] 165-5002-00	LP. #34 RT. NEWTON JACKPOT 165-5000-44-HF	LP. #35 BABY 1 (TOP) [4-BNK DRP/TRG] 165-5000-44-HF	LP. #36 BABY 2 [4-BNK DRP/TRG] 165-5000-44-HF	LP. #37 BABY 3 [4-BNK DRP/TRG] 165-5000-44-HF	LP. #38 BABY 4 (BOT) [4-BNK DRP/TRG] 165-5000-44-HF	LP. #39 LEFT ORBIT PUSS (IN BOOTS) 165-5000-44-HF	LP. #40 LEFT ORBIT JACKPOT 165-5000-44-HF
06 Q38 GROUND RED-BLU J12-P6	LP. #41 PINOCCHIO LIES [1-BNK DRP/TRG] 165-5002-00	LP. #42 SKILL SHOT 165-5000-44-HF	LP. #43 200K [TO LEFT RAMP] 165-5000-44-HF	LP. #44 300K [TO LEFT RAMP] 165-5000-44-HF	LP. #45 400K [TO LEFT RAMP] 165-5000-44-HF	LP. #46 500K [TO LEFT RAMP] 165-5000-44-HF	LP. #47 REPAY YOUR DEBT [TO L RAMP] 165-5000-44-HF	LP. #48 RALLY THE VIL-LIANS [MIRROR] 165-5000-44-HF
07 Q39 GROUND RED-VIO J12-P8	LP. #49 3 LITTLE PIGS [MIRROR] 165-5002-00	LP. #50 UN-HAPPY HOUR [MIRROR] 165-5000-44-HF	LP. #51 ONCE UPON A TIME [MIRROR] 165-5000-44-HF	LP. #52 DRAGON MULTI-BALL [MIRROR] 165-5000-44-HF	LP. #53 EXTRA BALL [LEFT NEWTON] 165-5000-44-HF	LP. #54 LEFT NEWTON JACKPOT 165-5000-44-HF	LP. #55 PUSS IN BOOTS JACKPOT 165-5000-44-HF	LP. #56 3 BANK STAND-UP [X STAND-UP] 165-5000-44-HF
08 Q40 GROUND RED-GRY J12-P9	LP. #57 3 BANK MID [X STAND-UP] 165-5002-00	LP. #58 3 BANK BOT [X STAND-UP] 165-5000-44-HF	LP. #59 NOT USED	LP. #60 NOT USED	LP. #61 LED WB WHT BOTTOM & TOP BUMPERS 112-5024-08 D.O.T.S.	LP. #62 MERLIN [MYSTERY] 165-5000-44-HF	LP. #63 DONKEY [STAND-UP X2] 165-5000-44-HF	LP. #64 SHOOT AGAIN 165-5000-44-HF
09 Q41 GROUND RED-WHT J12-P10	LP. #65 RIGHT ORBIT GINGY 165-5002-00	LP. #66 RIGHT ORBIT JACKPOT 165-5000-44-HF	LP. #67 SPINNER [GINGY] 165-5000-44-HF	LP. #68 MINI-PLAYFIELD SHOOT AGAIN 165-5000-44-HF	LP. #69 BALL SAVER POST 165-5000-44-HF	LP. #70 DONKEY SPOT LIGHT 165-5000-44-HF	LP. #71 NOT USED	LP. #72 NOT USED
10 Q42 GROUND RED J12-P11	LP. #73 NOT USED	LP. #74 NOT USED	LP. #75 NOT USED	LP. #76 NOT USED	LP. #77 NOT USED	LP. #78 NOT USED	LP. #79 NOT USED	LP. #80 NOT USED

▼ U.S. ▼
Customary
Inch Ruler



DREAMWORKS SHREK

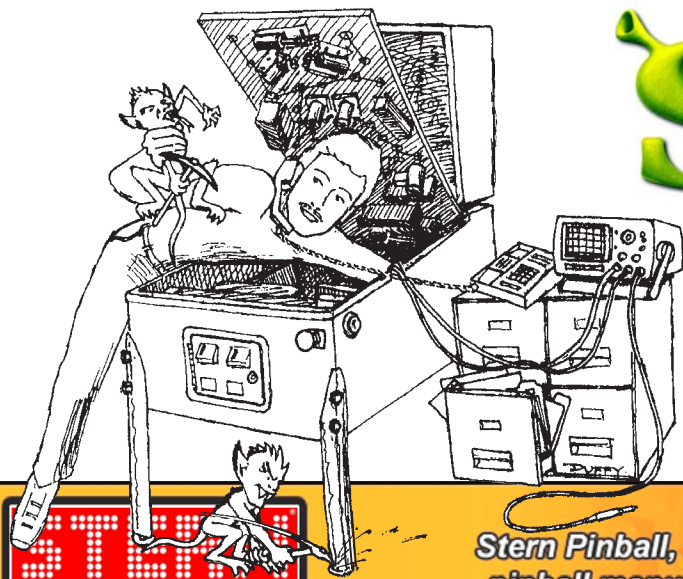

PINBALL, INC.

**Stern Pinball, Inc. is the only coin-op
pinball manufacturer on the planet!**

2020 Janice Avenue
Melrose Park, IL 60160
phone: 708.345.7700
fax: 708.345.7813
info@sternpinball.com

Tech. Support
& Parts Sales

Distributors

Pinball Links

Stern Info

Tournaments

Tour

Game Archive

Contact Us

Home

Technical Support & Parts Sales

[2002](#), [2003](#) (2-Disc Set) [2004](#) (2-Disc Set) & [2005](#) (2-Disc Set) & [2006](#) (3-Disc Set) CD-ROMs are now available! *Click year for more info!*

We at STERN Pinball continuously strive to provide our distributors, operators, and game owners with the best technical support possible. We, therefore, have provided you with the service options listed below. If your game requires parts and/or service, please contact your nearest STERN Pinball distributor (See our [Distribution List](#)). For any additional assistance, contact our technical service staff at 800-KICKERS (800-542-5377) or by e-mail (parts.service@sternpinball.com).

If your STERN Pinball is in need of repair, please contact your nearest [STERN Distributor](#).

Pinball Game Parts

- **2006+** Complete Pinball Service Game Manuals in PDF Format available (*includes parts and schematics*).
- **2004 — 2005** Select Pinball Service Game Manual Excerpts only : Parts Identification & Location (**The Pink Pages**), Drawings for Major Assemblies & Ramps (**The Blue Pages**)
- Appendixes **A — J** (*updated with each game*)

Schematics, Theory of Operation and Troubleshooting Tips

- Current S.A.M. System Games complete Schematic Section
- Archived Drawings for the White Star Board System™

Service Bulletins

- Detailing Technical Information, Tips, FYIs, Notices and Updates

NTE Semi-Conductor Cross Reference

Game Code Library

- Offering S.A.M. System Game Code
- Offering archived White Star Game Code for all Data East®, Sega™ and STERN® Pinballs (*EPROM Programmer required*)

Coinage Cards

- Offering a range of Coinage Cards for download
- Country Setting, Pricing Scheme, Dip Switch Setting (*opens a pop-up window*)
- [Custom Pricing Demonstration](#) (*for S.A.M. System*)

Tricks & Tips

- *Pinball Machine Foam Cushion Packing*
- *1st Time Pinball Set-Up & Preventative Maintenance*
- *Pinball Location Maintenance*
- *How to Update Your Game Code (S.A.M. System)*

Track Your Order Via UPS [Non-USA select your location](#)
[Radio Shack Component Catalogue](#)

Visit our website www.sternpinball.com for Pinball & Redemption game information!

Click  to view, print or download all of the above!

HELP US, HELP YOU! *If you have any suggestions, questions, need technical advice, find errors or have comments, contact us through our website or call!*

This Game Service Manual and all other documents relating to this product, playfield components, features, rules, programming and operation are subject to change without notice (Service Bulletins, if applicable, available through our website).



Metric Conversion

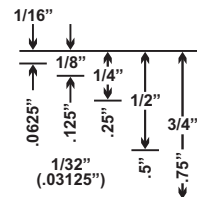

1" = 2.54 cm or 25.4 mm
1 cm = .3937"
1 mm = .03937"

For metric, multiply the inch value by the metric value:

e.g.: 5" X 2.54 cm = 12.7 cm or 127 mm

For US, multiply the metric value by the inch value:

e.g.: 13 cm X .3937" = 5.1181"

 Games shipped factory direct to Europe from Stern Pinball, Inc. are CE approved and will have an "E" prefix attached to the Serial Number.

800-KICKERS
5 4 2 5 3 7 7



After Set-Up

Machine Set-Up Procedures

...after reading the included Pinball Game Set-Up Instruction Sheet (SPI 755-5310-08) continue reading important info below:

(a) "The appliance has to be placed in a horizontal position." **(b)** "This appliance is not to be cleaned by a Water Jet."

UL 603335-7.12.1 (i) "Do not locate this appliance in an area where a Water Jet is used." **(ii)** "Do not clean this appliance with a Water Jet."

60335-7.12.5 (b) If the supply cord is damaged, it must be replaced by the manufacturer, its service agent or similarly qualified persons in order to avoid a hazard.

Backbox (backglass removed):

1. Check all connectors for loose wire terminations. Reseat any loose wire by pushing in on the terminal. Push on all plugged in connectors for the CPU/Sound, I/O Power Driver and the Display Power Supply Boards (check that they are properly seated). Ensure the Fluorescent Light Tube is seated correctly. Check that all fuses are seated properly (fuses on the I/O PCB have Red LED Status indicators). Reinstall backglass, lock the Backbox and secure its keys inside the Coin Door.

Playfield (glass removed):

2. Remove all shipping tie downs, shipping blocks, packing foam, etc., if present. **READ ALL PRINTED INFORMATION!** Shipping Instructions and/or Decals describe warnings, cautions, and/or important information specific to the game.

SAVE ALL IN CABINET!

If pinballs were already installed into the Ball Trough (under the arch), remove them before performing the following step. *****Pinballs can fall out and away from the playfield*****

3. Raise the playfield and rest it against the Backbox. See the illustration "Easy Access Service System - 2 Positions" on Page 4.

4. Visually inspect all cabinet cables and connector terminations; ensure no wires or cables are pinched and that cable harnesses are not pulled tight.

5. Make sure the proper amount of pinballs are installed (decal on the lock down assembly and the inside manual cover describe how many pinballs are needed).

6. Lower the playfield and ensure game is level side-to-side by adjusting Leg Levelers, if required. See the illustration "Leg Leveler Adjustment" on Page 4. Start with the Leg Levelers turned all the way in (1.25" from floor to bottom of leg), depending on the condition of the floor, adjust the Leg Levelers as required until the game pitch is 6.5°, determined by the Bubble Level.

USE THE BUBBLE LEVEL ON THE WOOD RAIL (LOWER RIGHT) TO DETERMINE IF LEVEL IS ACHIEVED. BUBBLE SHOULD APPEAR BETWEEN THE 2 BLACK LINES. SEE PAGE 4 FOR AN ILLUSTRATION.

The playfield incline affects difficulty of play. Use the recommended incline; Game difficulty is best varied using game adjustments.

With the Coin Door Open:

7. If desired, perform any self tests at this time (see Section 3, Chapter 1, Service Menu Introduction, and Chapter 2, GO TO DIAGNOSTICS MENU, for information on how to enter "Begin Play Test" and "Game Name Test" Menus, if any, to test components on the game).

8. If desired, adjust Game Pricing, Standard and/or Custom (see Section 3, Chapter 4, GO TO ADJUSTMENTS MENU and Section 3, Chapter 5, GO TO INSTALLS MENU to adjust Game Difficulty, 3- or 5-Ball Play, Competition or Home Settings, Novelty, Add-A-Ball, etc.).

If you saved your foam cushion packing materials and box, download the PINBALL MACHINE FOAM CUSHION PACKING 11" X 17" Color Sheet on-line on our website: <http://www.sternpinball.com/tips.shtml>

PINBALL GAME SET-UP

CAUTION: At least two (2) people are required to move and maneuver game. Use proper moving equipment & extreme care while handling. Pinball game is heavy! (200 lbs +/- 5 lbs) Boxed. Refer to Service Game Manual for further After Set-Up Procedures (Section 3, Chapter 1) and other important information!

TOOLS REQUIRED: S/S Socket Wrench, Utility Knife & Snps

- Before unpacking box, note the side which says "TRUCK THIS SIDE ONLY" this is the side the box will be cut. Note: If you want to "open" the box, lay box flat on its side, pull game out and sit back into the upright position as shown. Use a standard 1/2" ratchet to protect floor.
- With top of the box open, remove the four (4) foam pieces and the two (2) narrow box tubes which contain the four (4) identical Legs with Levelers (2 per side).
- At this point DO NOT CUT STRAPPING (You want to keep the Backbox secured in the down position).
- With the utility knife, CAREFULLY cut down on the left and right sides of the box. Carefully remove the entire side by carefully cutting the bottom edge.
- With the S/S Socket Wrench, remove the 2 Leg Bolts on each side of the front cabinet.
- Install FRONT LEGS using the bolts removed from Step 5. Secure tightly. Take care not to scratch the Finish on any of the Legs.
- Remove 2 Bolts per side.
- Carefully lift the game down on the FRONT LEGS. Care should be taken to ensure the game is level. SET THE OPEN BOX.
- With the S/S Socket Wrench, loosen and remove the 2 Leg Bolts on each side of the rear cabinet.
- Using supports on two (2) people, prop the rear of the cabinet up. (See 200 lb. max. weight limit on the back of the cabinet.)
- Install REAR LEGS using the bolts removed from Step 8. Secure tightly. Take care not to scratch the Finish on Legs.
- CUT NYLON STRAPPING. CAUTION: Strapping can SNAP - protect your eyes! Use extreme care when using a utility knife. Remove all V-Clamps.
- After the BACKBOX is in the UPRIGHT POSITION, locate the S/S HEX KEY. (S/S means: stainless steel) with a 3/8" hex nut - attached & locked.
- With the keys removed, open the COIN DOOR. Pull the YELLOW HANDLE to the LEFT and all the keys will pop up on the FRONT TOP. INCLUDING, remove and set aside.
- Install the PLUMB BOB. (See Section 3, Chapter 1, Service Menu Introduction, and Chapter 2, GO TO DIAGNOSTICS MENU, for information on how to enter "Begin Play Test" and "Game Name Test" Menus, if any, to test components on the game).

NOTE: COIN DOOR KEYS are in the Service Menu. If you are in need to the Right Side of the Coin Door, use the Right Side of the Coin Door. (See Section 3, Chapter 1, Service Menu Introduction, and Chapter 2, GO TO DIAGNOSTICS MENU, for information on how to enter "Begin Play Test" and "Game Name Test" Menus, if any, to test components on the game).

REAR SERVICE MOUNTING: Remove the REAR SERVICE MOUNTING. (See Section 3, Chapter 4, GO TO ADJUSTMENTS MENU, for information on how to enter "Begin Play Test" and "Game Name Test" Menus, if any, to test components on the game).

PLAYFIELD GLASS: The PLAYFIELD GLASS can now be pulled out forwards and removed. TAKE CARE while moving, as glass can be quite heavy (depending on recommended).

REAR SERVICE MOUNTING: Remove the REAR SERVICE MOUNTING. (See Section 3, Chapter 4, GO TO ADJUSTMENTS MENU, for information on how to enter "Begin Play Test" and "Game Name Test" Menus, if any, to test components on the game).

STERN PINBALL THE ORIGINAL

Sec. 1: After Set-Up



PINBALL GAME SET-UP

CAUTION: At least two (2) people are required to move and maneuver game. Use proper moving equipment & extreme care while handling. Pinball game is heavy! 280lbs (+/- 5) Boxed. Refer to Service Game Manual for further **After Set-Up Procedures** (Section 1, Chapter 1) and other important information!

TOOLS REQUIRED:

5/8" Socket Wrench, Utility Knife & Snips

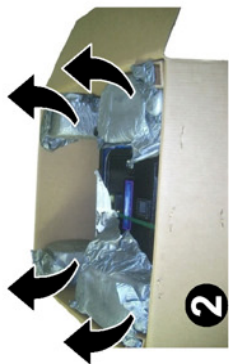

1. Before unpacking box, note the side which says "TRUCK THIS SIDE ONLY" (this is the side the box will be cut). **Note:** If you want to "save" the box, lay box flat on this side, pull game out and tilt back into the upright position as shown. Use of a blanket is then required to protect floor.
2. With top of the box open, remove the four (4) foam pieces and the two (2) narrow box tubes which contain the **four (4) Identical Legs with Levelers (2 per tube)**.

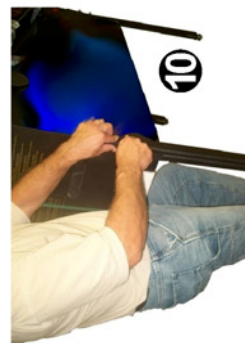
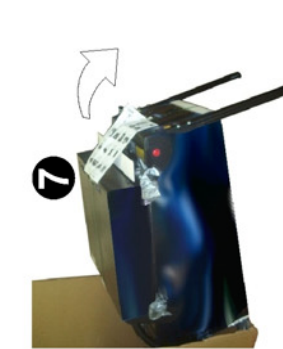

7. Carefully set the game down on the **FRONT LEGS**. Care should be taken... **Game is heavy, two (2) people are recommended for this and the following step. SET ASIDE THE OPEN BOX.**
8. With the 5/8" Socket Wrench, loosen and remove the 2 Leg Bolts on each side of the rear cabinet.
9. Using supports or two (2) people, prop the rear of the cabinet up. (Not shown in pictures is second person handling legs and bolts to the installer.)
10. Install **REAR LEGS** using the bolts removed from **Step 8**. Secure tightly. Take care not to scratch the **Finish on Legs**.

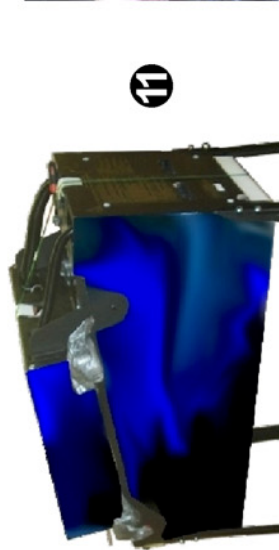
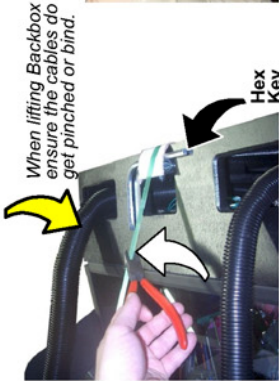

11. Cut NYLON STRAPPING. **CAUTION:** Strapping will SNAP, protect your eyes! Use extreme care when using a utility knife, snips. Remove all V boards.

12. After the BACKBOX is in the UPRIGHT POSITION, locate the 5/16" HEX KEY. While inserted, rotate KEY with a 3/4 turn until latched & locked.

13. With the keys removed, open the COIN DOOR. Pull the YELLOW HANDLE to the LEFT and at the same time pull up on the FRONT TOP MOLDING, remove and set aside.

NOTE: COIN DOOR KEYS are tied to the Shooter Rod* (if equipped) or taped to the Playfield Glass (if equipped with Auto Plunger Button). Remove keys. BACKBOX KEY are located inside Coin Door. Backbox Lock (remove Backglass to access the CPU/Sound and I/O PCBs).

ALWAYS STORE THE GAME SERVICE MANUAL & INFORMATION SHEETS INSIDE THE CABINET WHEN NOT USING.

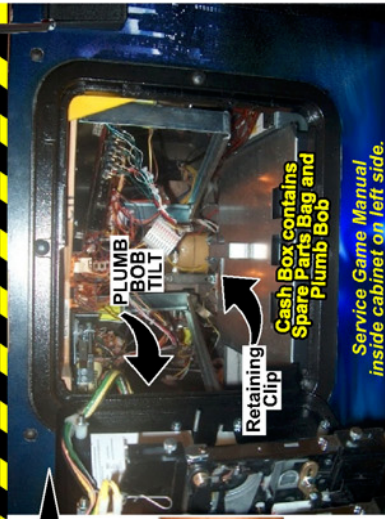

14. Through the open Coin Door, remove the RETAINING CLIP at the rear of the CASH BOX and open. Remove the PINBALLS & the PLUMB BOB from the SPARE PARTS BAG (save the other spare parts in cabinet). Install the PINBALLS by placing them on the playfield so they can roll down between the lower flippers into the Ball Trough (the amount of pinballs to install noted under FRONT TOP MOLDING or 1st page of manual). **Remove any shipping materials which may be present. Check for parts which may have come loose during transportation and secure.**

15. Install the PLUMB BOB (located in parts bag in cash box) onto the Hanger Wire & tighten the Thumb Screw. Loosening the Thumb Screw & lowering or raising the PLUMB BOB makes the Games Tilt Function more or less sensitive (tilt warnings adjustable through DIAGNOSTICS, GO TO ADJUSTMENTS MENU).

16. The PLAYFIELD GLASS can now be pulled out forwards and removed. **TAKE CARE** while moving, set glass on a safe surface (carpeting recommended).

Remove the GAME SERVICE MANUAL (stapled to side of the left wall of the cabinet). Review Section 1, Chapter 1, Page 1, and perform Steps 1 - 8+. Review the end of this chapter on how to lift the playfield to access the Plumb Bob Tilt. **READ YOUR SERVICE GAME MANUAL** and review the SERVICE MENU (Diagnostics, Adjustments, Installs), Parts & Schematics. **GAME SERVICE MANUALS ON-LINE:** <http://www.sterminball.com/techsupport.shtml>

Remove the GAME SERVICE MANUAL (stapled to side of the left wall of the cabinet). Review Section 1, Chapter 1, Page 1, and perform Steps 1 - 8+. Review the end of this chapter on how to lift the playfield to access the Plumb Bob Tilt. **READ YOUR SERVICE GAME MANUAL** and review the SERVICE MENU (Diagnostics, Adjustments, Installs), Parts & Schematics. **GAME SERVICE MANUALS ON-LINE:** <http://www.sterminball.com/techsupport.shtml>

How to Secure the Backbox for Transporting

Sec. 1: After Set-Up

For more Backbox details & part numbers, see Section 4, Chapter 1, Parts Id. & Location, Backbox Assembly.

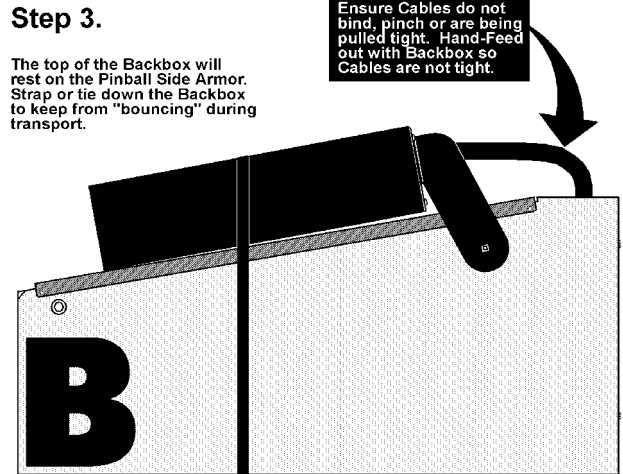
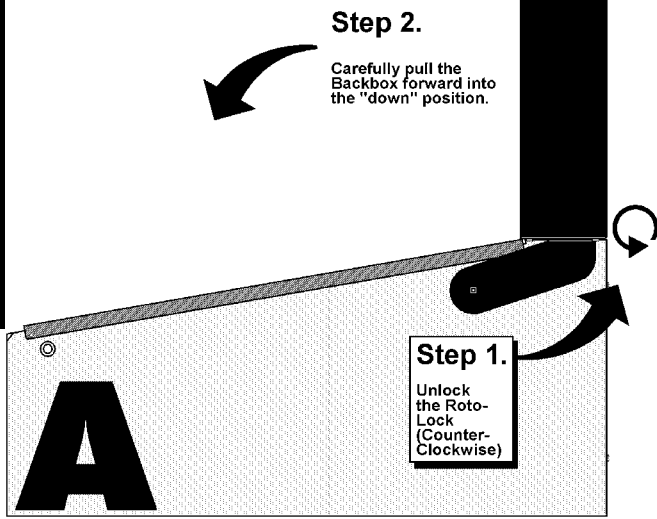

Leg Leveler Adjustment

Attach the four (4) Leg Assemblies to cabinet corners with the eight (8) leg bolts provided .

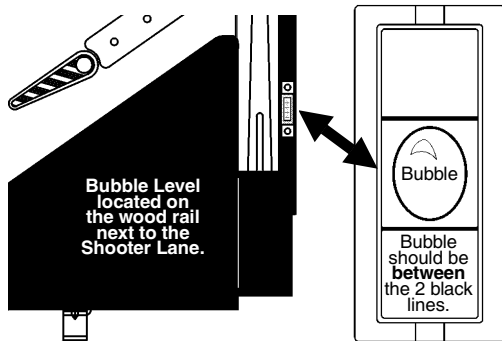

Start adjustment with the leg levelers *turned all the way in*.

View the *bubble* in the level provided on the right side wood rail.

Adjust the front or rear levelers as necessary to cause the bubble to float between the two (2) black lines.

Use a pinball to roll down the center of the playfield for side-to-side leveling.

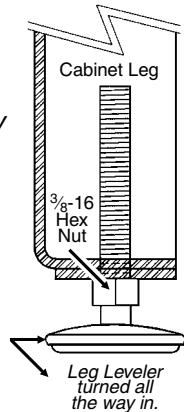

YOUR PLAYFIELD PITCH IS NOW AT 6.5° AS REQUIRED FOR PROPER GAME PLAY!

Note: For custom adjustment greater than >6.5° can be achieved by turning out the rear leg leveler(s), however, it is not recommended.

Easy Access Service System - 2 Positions

With the front molding & glass removed, carefully lift the playfield (*take care when using the Bottom Arch to hoist*).

Position 1

When lifted high enough, the **Playfield Support Slide Brackets** (Fig. 1A) can be seen and can clear the cabinet front (Fig. 1B). At this time, pull the playfield toward the front of the cabinet, checking that the mechanical components clear the cabinet front, then rest the playfield on the **Playfield Support Slide Brackets** at the front channel of cabinet (Fig. 1C);

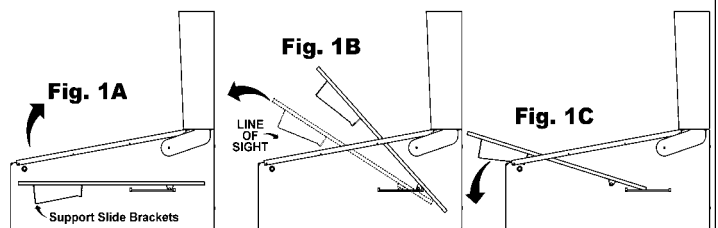

Position 2

With the playfield at rest, hold the sides & pull toward the front of the cabinet (*approx. 6" to 8"*), until resistance is felt from **Edge Slide Brackets** stopping against the **Slide & Pivot Support Brackets** located on either side of the cabinet (Fig. 2A). At this time, swivel the playfield toward the Backbox, then rest on the top edge (Fig. 2B & 2C).

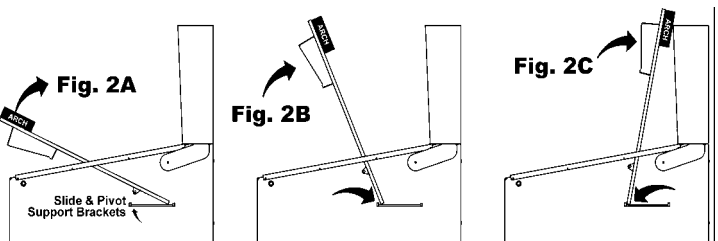

Game Operation & Features

Start of Game Features

Starting a Normal Game

Insert coin(s). The game generates a sound for the first coin & for each subsequent coin with the display indicating the number of credits posted. Press the **Start Button** and a start-up sound is produced, and the posted credits are reduced by one. Subsequent players can be added (**up to 4 can play!**) by pressing the **Start Button** before the end of ball 1 (*with sufficient credit in the game*).

The display now indicates the player or # of players selected from the total depressions of the **Start Button**. The display indicates the ball in play, and a ball is served to the *Shooter Lane*. Pressing the **Start Button** after ball 1 of any player will start a new game (*if credits are available*), **but only** if the **Start Button** is depressed for 2-3 seconds. This delay is to avoid accidental "re-starts" of a game. **Note:** *Any partial credit remaining during game play after the end of the first ball, or power down, will be eliminated.*

Starting Team Play (Doubles!)

This option is adjustable with **Standard Adjustment (Adj.) 58, Team Scores** (Default = **NO**). If **Standard Adj. 58, Team Scores** is changed to **YES**, then Team Play will be made available. **Team Play only works in a 4-Player Game**. The totals for Players 1 / 3 (Team 1) & Players 2 / 4 (Team 2) are then displayed individually **as well as** the combined score for **BOTH TEAMS**.

Starting Tournament Play

This Pinball Game is **Tournament Ready**. **Optional Tournament betaBRITE Color Dot Display & hardware (sold separately) is available**. Review **Section 3, Chapter 6, GO TO TOURNAMENT MENU**, for more info!

Unlike a "Normal Game", the Tournament Game is started by depressing the **Tournament Start Button** (*located on the Front Molding, if installed*). If adequate credit(s) are posted **and a Tournament is started (set-up properly)** via the **Service Menu** (*select the "TOUR" Icon in the Main Menu*), the **Tournament Start Button** will flash. *Any adjustments or installs changed will not be in affect. Starting a Tournament Game defaults to preprogrammed Tournament Rules (e.g. No Extra Balls, Specials or Bonus Credits are awarded); however, starting a Normal Game after a Tournament Game will then revert back to any unique adjustments or installs performed previously.* **During** and **End of Game Features** operate in the same manner.

During Game Features

Video Mode

Our games may feature video interactive play modes. *Also, don't forget to watch the display for hints or instructions.* The interactive video modes require the player to play on-screen using the flipper buttons. When in video mode, the ball-in-play is "held" (*usually in a Scoop, Eject Saucer or lock of some sort*).

During Game Features Continued

Feature Mode & Combination Shots

Features are lit on the playfield and started by completing *certain shots (e.g. completion of Target Banks, Orbit(s), Ramp(s) and/or any combination of the shots)*.

Multiball

Multiball is started after completion of certain features (*amount of balls used depends on game rules*).

Replay Feature

Replay awards are given as the player exceeds a High Score Level during game play. This can be adjusted with **Standard Adj. 3, Replay Award** (Default = **CREDIT**). Players exceeding the High Score Levels can receive: **CREDIT, EXTRA BALL, or SPECIAL**. Adjust to **NONE** if a replay award is not desired.

End of Game Features

Game Endings

When all player(s) have played all balls (including any Extra Balls), the game ends. If power is interrupted during the course of a game, it will end that game (**see Starting a Normal Game**). Closure of the Plumb Bob Tilt Switch according to the number of tilts set, **Standard Adj. 22, Tilt Warnings** (Default = **2**) or prolonged closure, will end the current Ball-In-Play. Closure of the Slam Tilt Switch on the Coin Door ends the current game(s).

Match Feature

At the end of each ball, earned bonuses are collected. At the end of the last ball of a game (including any extra balls, if applicable), earned bonuses are collected, then the system produces a random 2-digit number (a multiple of 10; 00 to 90). Matching the last 2 digits of the player's score with this number awards a credit. In **Std. Adj. 19, Match Percentage** (Default = **9%**) can be changed from 0-10%. Changing the percentage to **0% displays** the "Match Animation" at the end of the game, however, will never match nor award anything. Changing this adjustment to **OFF** will **not display** the "Match Animation" nor award anything.

Entering Initials/Name

If player achieved a new *High Score* in a game or achieved a *Special Feature (if given)* the player may enter 3 Initials. In **Std. Adj. 36, HSTD (High Score To Date) Initials** (Default = **3 Initials**) can also be changed to **10-Letter Name**. Use the **Flipper Buttons** to choose a letter or character as seen on the Dot Display. Hitting the **Start Button** locks in the letter or character and proceeds to the next letter. The game then proceeds into the **Game-Over Mode** and then to the **Attract Mode**.

Note: **Standard Adj. 41, Custom Message** (Default = **ON**) can be displayed during the **Attract Mode**; enter letters in the same fashion. For more details on Adjustments, see **Section 3, Chapter 4**.

... continued on the next page.

Auto Percentaging

This game is equipped with Auto Percentaging, **Standard Adjustment (Adj.) 1, Replay Type** (Default = **AUTO**, adjustable). The *Replay Percent* is automatically adjusted, **Standard Adj. 2, Replay Percentage**, or you can set a *Fixed Replay Score*. Four levels may be selected. Adjustments allow awarding of a "CREDIT" (or your setting) as each level is exceeded. This can be adjusted with, **Standard Adj. 3, Replay Award** (Default = **CREDIT**). With the **Autopercentage Feature**, if the actual replay percentage is higher or lower than that desired, the game will automatically adjust for the new recommended percentage score(s). You may choose to make a different "score-to-beat" adjustment; this is done by utilizing **Standard Adj. 4, Replay Levels**. For more details with **Adjustments**, see **Section 3, Chapter 4, GO TO ADJUSTMENTS MENU**; also, see **Section 3, Chapter 5, GO TO INSTALLS MENU** (via the **UTILITIES MENU**) for further customization of your Pinball Game.



Print on Astrobrights® Solar Yellow #65
Wausau Paper Products (Stock #22731).

Sec. 2: Game Op.

Instruction Card

Below is a **COPY** of the Game Instruction Card (SPI Number: **755-51A5-12-Y English Front / Spanish Back**). For a replacement *Game Instruction Card* simply **COPY** this page and *cut out* the card as a *temporary replacement* until a *new card is ordered through your distributor*; or *download from our website, www.sternpinball.com*, and *click on the pinball game desired or click the the Game Archive link*. *Multiple language Instruction Cards are included with the PDF.*



COPY & CUT

Para jugar Donkey's Mini-Pinball, escribe P-I-N-B-A-L-L, pegando a las **bolas cautivas**. Después de formar la palabra **P-I-N-B-A-L-L**, dispara al **cucharon del Pantano de Shrek** para iniciar "el juego De Donkey Pinball" en el campo de juego pequeño.

Donkey Pinball El nombre del personaje aparece deletreado con luces en el campo de juego pequeño. Cada tiro en esta mesa agrega una letra al nombre del personaje. Deletrea el nombre de cada personaje para encender su rostro en el campo de juego. Debes encender el rostro de todos los personajes para iniciar el **Multiball de Donkey**.

Multiball Pégale a las cuatro dianas abatibles de la bancada para avanzar en el **Multiball**. Pégale a la diana abatible de la bancada para avanzar en el **Multiball**.

Guardia De Castillo Dispara a la diana el Gato con botas (en el extremo superior izq.) para bajar la diana del Guardia De Castillo y avanzar hacia el premio del Guardia De Castillo. Acumula los 5 premios del Guardia De Castillo para comenzar el modo **Pagar lo que Devez**.

1 diana abatible de la bancada de Pinocchio Pégale a la diana abatible de la bancada de Pinocchio para subir el poste salvador de la bola y hacer a Pinocchio mentir.

Extra Ball Dispara a la rampa izquierda varias veces para encender el tiro de la Extra Ball.

Sugerencia: Dispara a la diana hielador (Spinner) para encender el Pantano De Shrek.

To Play Donkey's Mini-Pinball, spell P-I-N-B-A-L-L by hitting the **Captive Balls**. After spelling **P-I-N-B-A-L-L**, shoot **Shrek's Swamp Scoop** to start "Donkey Pinball" on the mini-playfield.

Donkey Pinball The name of each character is spelled out in lights on the mini-playfield. Each mini-playfield shot adds a 'letter' to a character's name. Spell out each character's name to light their face on the playfield. Get all the character faces to start **Donkey Multiball**.

Multiball Hit the **4-Bank Drop Targets** to advance to **Multiball**.

Castle Guard Shoot the **Puss In Boots Target** (upper left) to lower the **Castle Guard Target** and advance the **Castle Guard Award**. Collect all **5 Castle Guard Awards** to start **Repay Your Debt**.

Pinocchio 1-Bank Drop Target Hit the **Pinocchio 1-Bank Drop Target** to raise the **Ball Saver Post** and make **Pinocchio lie!**

Extra Ball Shoot the **Left Ramp** multiple times to light the **Extra Ball Shot**.

Hint: Shoot the **Spinner Target** (right orbit) to light **Shrek's Swamp**.

Shrek® Ears and Shrek "S" TM & ©2008 DreamWorks L.L.C., Shrek Evergreen TM & ©2008 DreamWorks Animation L.L.C. 755-51A5-12-Y English
Shrek Pinball, Inc. All Rights Reserved.

FOLD HERE





- Chapter 1, Service Menu Introduction8 – 12**
 - ▶ Table of Contents for Section 3.....7
 - ▶ **Service Switch X4 Set Acces & Use**8
 - ▷ Function 1: SERVICE CREDITS MENU ▷ Function 2: VOLUME MENU ▷ Function 3: SERVICE MENU
 - ▶ **Service Menu Introduction**9
 - ▷ How to Use This Section
 - ▶ **Shrek® Pinball Service Menu Icon Tree**10-11
 - ▶ **Exit Service Menu**.....12
 - ▷ Problem / Solution Table
- Chapter 2, GO TO DIAGNOSTICS MENU13 – 20**
 - ▶ **Go To Switch Menu**14
 - ▷ Switch Test ▷ Active Switch Test ▷ Switch Alerts
 - ▶ **Go To Coil Menu**15
 - ▷ Single Coil Test ▷ Cycling Coil Test
 - ▶ **Go To Flash Lamps Menu**15
 - ▷ Single Flash Lamp Test ▷ Cycling Flash Lamp Test
 - ▶ **Go To Lamp Menu**16
 - ▷ Single Lamp Test ▷ All Lamps Test ▷ Row Lamps Test ▷ Column Lamps Test ▷ Ordered Lamps Test
 - ▶ **Donkey Motor Test (Shrek Test)**.....17
 - ▶ **Ball Trough Test**17
 - ▶ **Technician Alerts**.....18
 - ▶ **Knocker Test ▶ Sound / Speaker Test ▶ Begin Burn-In**19
 - ▶ **Dot Matrix Test**.....20
- Chapter 3, GO TO AUDITS MENU21 – 24**
 - ▶ **Earnings Audits [#1 – #13 Definitions]**.....21
 - ▶ **Standard Audits [#1 – #59 Definitions]**.....22-23
 - ▶ **Feature Audits [#1 – #70]**.....24
 - ▶ **Tournament Audits [#1 – #14] subject to change**.....24
 - ▶ **Dump Audits to USB**24
- Chapter 4, GO TO ADJUSTMENTS MENU25 – 34**
 - ▶ **Standard Adjustments [#1 – #63]**.....25-32
 - ▶ **Feature Adjustments [#1 – #25]**33-34
- Chapter 5, GO TO UTILITIES MENU35 – 40**
 - ▶ **Go To Installs Menu**.....35-38
 - ▷ Install Extra Easy ▷ Install Easy ▷ Install Medium ▷ Install Hard ▷ Install Extra Hard ▷ Install 3-Ball ▷ Install 5-Ball
 - ▷ Install Competition ▷ Install Directors Cut ▷ Install Home Play ▷ Install Novelty ▷ Install Add-A-Ball ▷ Install Factory
 - ▶ **Enter Custom Message**.....39
 - ▶ **Set Custom Pricing**39
 - ▶ **Set Date / Time**.....40
 - ▶ **Go To Resets Menu**40
 - ▷ Reset Coin Audits ▷ Reset Game Audits ▷ Reset Grand Champion (Score) ▷ Reset High Scores ▷ Reset Credits
 - ▷ Reset Factory Settings
 - ▶ **Go To USB Menu**40
 - ▷ Dump to USB Memory Stick ▷ Update Game Code ▷ Backup to USB Memory Stick
- Chapter 6, GO TO TOURNAMENT MENU41 – 42**
 - ▶ **Start Tournament / Stop Tournament**41-42
 - ▶ **View Tournament Data**42
 - ▶ **Tournament Audits [#1 – #14]**42
 - ▶ **Sign Messages A-B**42

Sec. 3: ...Menu Intro.



Service Switch X4 Set Access & Use

The 4-Button Service Switch Set provides access for **three (3) functions** available for your use: 1: **SERVICE CREDIT**, 2: **VOLUME [-] / [+]** and 3: **SERVICE MENU**.

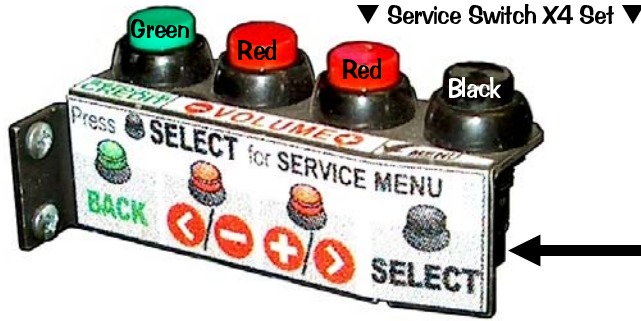

Inside Coin Door

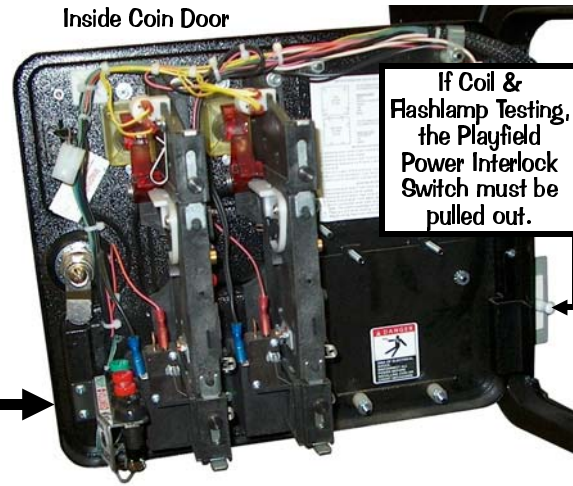

If Coil & Flashlamp Testing, the Playfield Power Interlock Switch must be pulled out.

To access any of these **three (3) functions** you must first open the **Coin Door** (see pictorial above) with the Game in the **Attract Mode** (not already in any Function or Menu stated below) and then follow below.

Pushing the **GREEN** BUTTON first.



◀ Function 1: SERVICE CREDITS MENU

Pushing the Green [**SERVICE CREDIT**] Button first, adds a **Service Credit** per push (will not affect your audits as "paid" credits). This is useful for the technician to test games in regular play without affecting the game audits. Each depression adds **1 credit**; up to **50 credits** can be applied. **Standard Adjustment 23, Credit Limit**, determines this, however, it can be changed from 04-50; for details see Chapter 4 of this Section 3.

Note: Once your credits are added, this menu will **automatically exit** a few seconds after the last button depression or when the Green [**BACK**] or Black [**SELECT**] Button is pushed. This function is disabled if **Standard Adjustment**

38, Free Play, is set to **YES**. The Service Credits are limited to the Credit Limit in addition to any paid credits present in the game (e.g. If the Credit Limit is 30, with 8 paid credits present, only 22 Credits can be applied.)

Pushing either **RED** BUTTON first.



Pushing either **RED** BUTTON first.



▲ Function 2: VOLUME MENU ▲

Pushing either of the Red [**VOLUME**] Buttons first, enters the **VOLUME MENU**. While in this Mode, to **DECREASE** the volume, hold down or depress the **1st Red [</-] Button** until desired the volume is achieved; to **INCREASE** the volume, hold down or depress the **2nd Red [+/>] Button** until the desired volume is achieved.

Note: The volume can be set between **0-63**; Once your adjustments are made, this menu will **automatically exit** a few seconds after the last button depression or when the Green [**BACK**] or Black [**SELECT**] Button is pushed.

Pushing the **BLACK** BUTTON first.



◀ Function 3: SERVICE MENU

Pushing the Black [**SELECT**] Button first, enters the **SERVICE MENU**. Once in, navigate through all menus by depressing the **Service Menu Buttons**. Use the Red [**</-**] or [**+/>**] Buttons to move **LEFT / RIGHT, NEXT/PREVIOUS (audits/adjustments)** or to **INCREASE / DECREASE** an adjustment (setting). Use the **Black [SELECT] Button** to select a highlighted **Icon**, move to the next line of text or to answer **"OK"** where applicable. Use the **Green [BACK] Button** to exit or escape back.

Please read Section 3, Chapters 2-6, for explanation on all **Icons and Menus. Read! Read! Read!**

Sec. 3: ...Menu Intro.



Service Menu Introduction

Important: The **Switch Bracket** holds the **Playfield Power Interlock**. It is located just inside the **Coin Door** frame (see pictorial of the **Coin Door** on the previous page). The **Button Switch** for the **Playfield Power Interlock Switch** must be pulled out for electro-mechanical device testing or diagnostic purposes (this is required). If this button is pushed in, the **Playfield Power** is disabled while the **Coin Door** is **OPEN**.

How to Use This Section

This section will cover all functions available in the **SERVICE MENU** in a *Step-By-Step* process. This section is divided into **chapters** which coincide with the **MAIN MENU** (will also provide more detailed information). The previous and following pages in this Chapter will instruct the operator on how to move through the Menus. *It's simple, easy and fun to use!*

To get into the **SERVICE MENU MODE** review "**Function 3: SERVICE MENU**" on the previous page. After Power-Up, push down the **Black [SELECT] Button** to begin. Looking at the display you will momentarily see "**SERVICE MENU**" followed by the **MAIN MENU**:



Use the **Red [</-] / [+ / >] Buttons** to move the selected **Icon** left or right, and the **Black [SELECT] Button** to activate the selected **Icon**.

The **MAIN MENU** now appears with the "DIAG" **Icon** (**GO TO DIAGNOSTICS MENU**) highlighted:



As the operator views the Menu Screen(s), the **MORE MORE** symbols indicates that there are more **Icons** to select in each direction. The **Icon** selected will blink. Pushing the **Black [SELECT] Button** will select the **Icon** and the Menu Screen will change to the menu selected. Select the **Green [BACK] Button** to move backwards through the menu levels. Press the **Green [BACK] Button** repeatedly or select the "**QUIT**" **Icon** to completely exit the **SERVICE MENU** Mode.

View the **SERVICE MENU Icon Tree** on the next pages for a complete overview of all menus used in this system. The "**HELP**" **Icon** provides an explanation of **ICON** usage or any other information in the Menu where the "**HELP**" **Icon** was selected (when available).

DIAG: GO TO DIAGNOSTICS MENU | **AUD:** GO TO AUDITS MENU | **ADJ:** GO TO ADJUSTMENTS MENU
UTIL: GO TO UTILITIES MENU (INSTALLS, CUSTOM MSG., CUSTOM PRICING, SET TIME, RESET & USB)
TOUR: GO TO TOURNAMENT MENU (START TOURNAMENT, VIEW TOURNAMENT DATA, SIGN MESSAGES)

>> TO UPDATE THE GAME CODE, REVIEW THE STEPS ON THE INSIDE FRONT COVER OF THIS MANUAL.

Use both the manual and the display to help customize, troubleshoot and/or diagnose faults, if any.

Shrek® Pinball Service Menu Icon Tree

Sec. 3: ...Menu Intro.

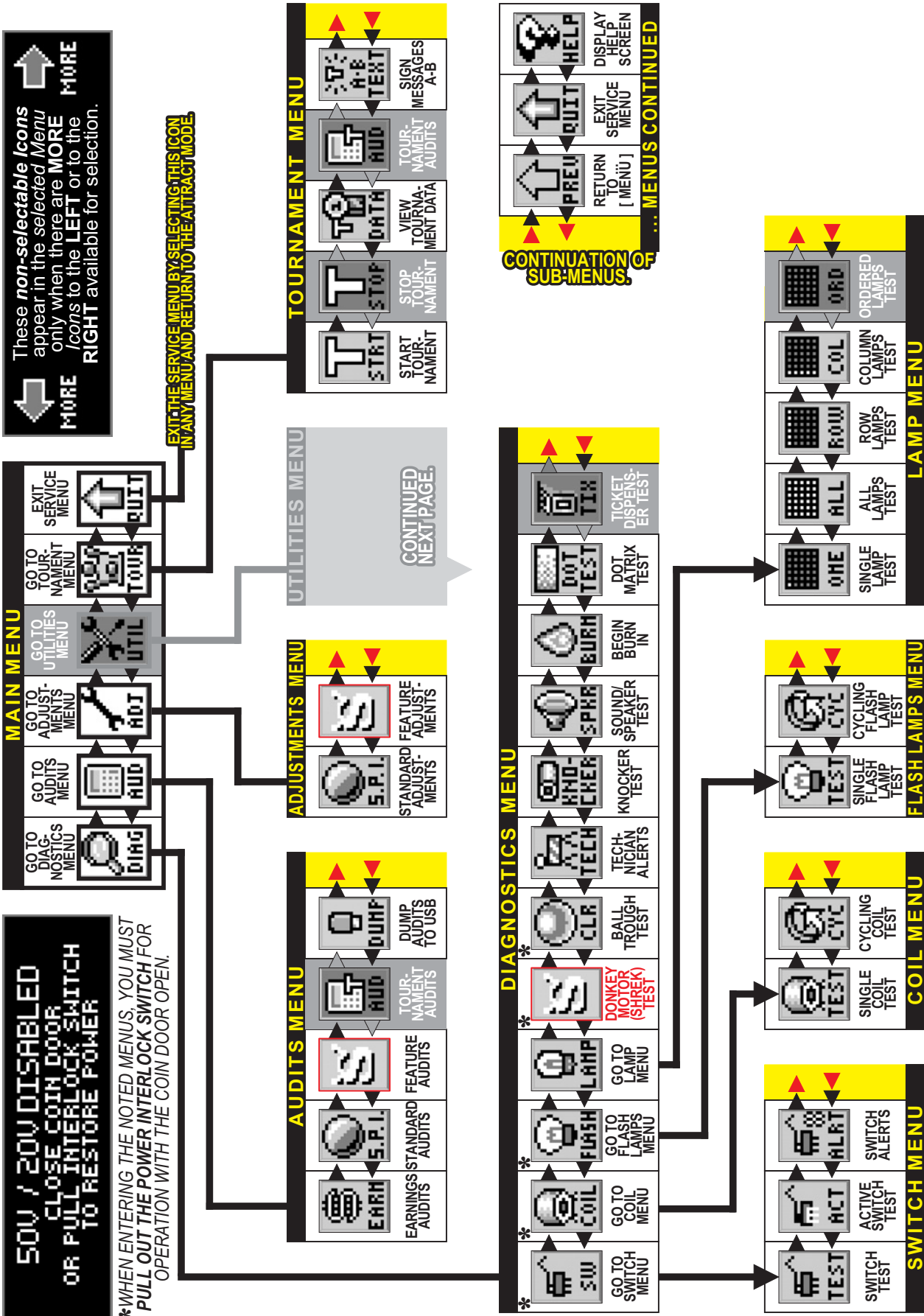

Shrek® Pinball Service Menu Icon Tree Continued

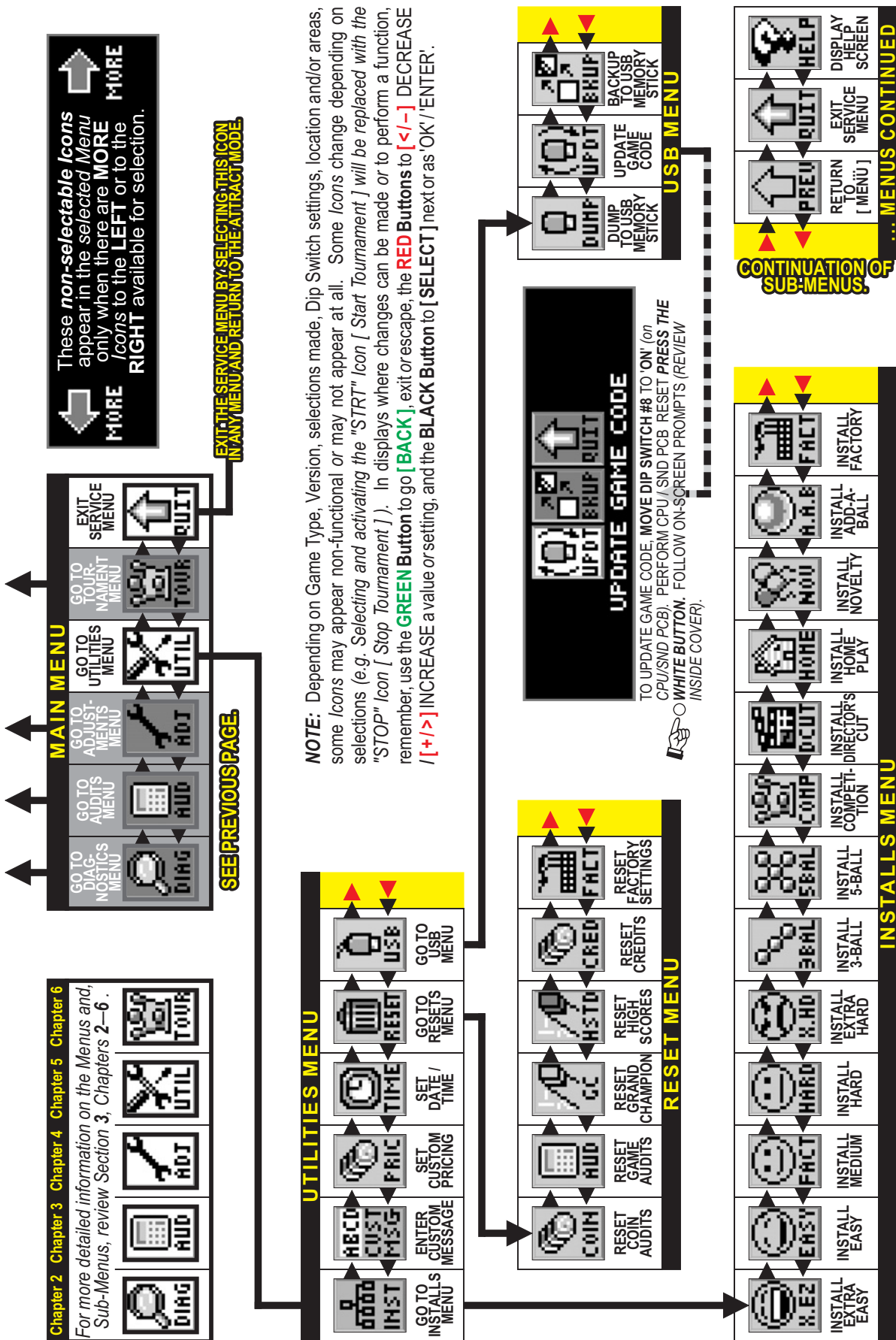

These non-selectable Icons appear in the selected Menu only when there are MORE Icons to the LEFT or to the RIGHT available for selection.

EXIT THE SERVICE MENU BY SELECTING THIS ICON IN ANY MENU AND RETURN TO THE ATTRACT MODE.

SEE PREVIOUS PAGE.

NOTE: Depending on Game Type, Version, selections made, Dip Switch settings, location and/or areas, some Icons may appear non-functional or may not appear at all. Some Icons change depending on selections (e.g. Selecting and activating the "STRT" Icon [Start Tournament] will be replaced with the "STOP" Icon [Stop Tournament]). In displays where changes can be made or to perform a function, remember, use the GREEN Button to go [BACK], exit or escape, the RED Buttons to [< / -] DECREASE [+ / >] INCREASE a value or setting, and the BLACK Button to [SELECT] next or as 'OK' / 'ENTER'.

Note: Press [SELECT] to Install; Press [BACK] to cancel. After selection of any of the Install Icons, the request is installed and returns to the Install Menu. The last icon activated before exiting this menu will supersede any previous icon selected in the group.

Sec. 3: ...Menu Intro.



Exit Service Menu

In the **MAIN MENU** and in all **SUB-MENUS** (where the "QUIT" Icon is present), if the "QUIT" Icon is selected and *activated*, or the **Green [BACK] Button** is selected repeatedly (depending on which sub-menu you're in...), the **SERVICE MENU Session** will be exited and returned to the **Attract Mode**.

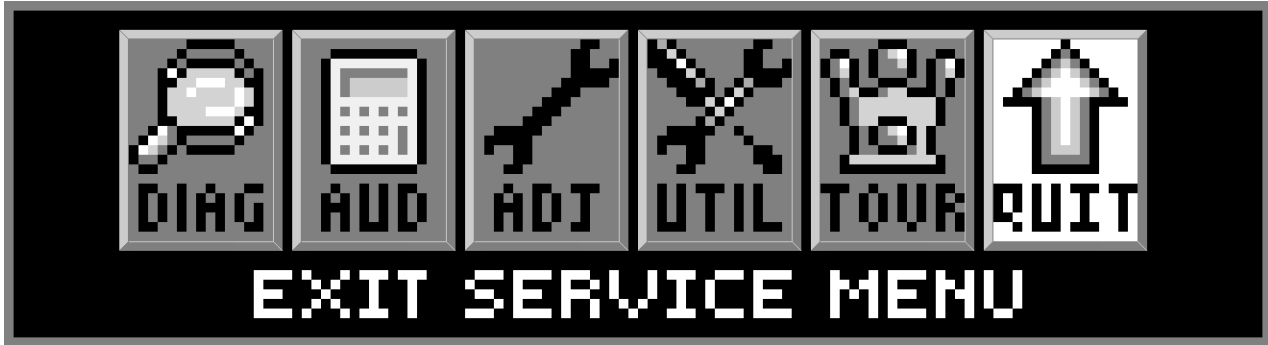

Turning the game on/off will start the *Power-Up Routine*. Upon **Power-Up**, the DISPLAY will indicate the COUNTRY, FILE VERSION and LANGUAGE(S) installed. LANGUAGE/COUNTRY: change via Dip Switch.



The below **Problem / Solution Table** was designed to answer some common problems frequently asked.

Problem / Solution Table

PROBLEM	SOLUTION
Will not enter the SERVICE MENU after depressing the Black [SELECT] Button .	<ul style="list-style-type: none"> • Check the Service Switches [GREEN, RED (x2) & BLACK Buttons] for loose connections or bad ground. • Check the associated wiring harness to/from the CPU/Sound Board, Connector J13. • Check CPU/Sound Board for possible failure.
All Service Buttons [•••• Buttons] appear nonfunctional.	<ul style="list-style-type: none"> • Check the Service Switches wiring harness for poor or no connection and/or broken wires.
The Green Button in the Attract Mode will not enter the SERVICE CREDITS MENU to add Service Credits.	<ul style="list-style-type: none"> • Check to make sure the Game is not in "Free Play." <i>If the game is set to Free Play, adding Service Credits is not required.</i> • Check the Service Switches wiring harness for poor or no connection and/or broken wires.
The Display "blanks out."	<ul style="list-style-type: none"> • Check the Dot Matrix Display for loose wiring harness for poor or no connection and/or broken wires. • Check F1 (3/4A Fuse) on the Display Power Supply Board. Refer to Section 5, SCHEMATICS & TROUBLESHOOTING.
Icons "scroll" along continuously in the MAIN MENU .	<ul style="list-style-type: none"> • Check for a stuck switch on either of the Red Buttons.
The Start and Flipper Buttons do not select or activate <i>Icons</i> in the SWITCH TEST MENU .	<ul style="list-style-type: none"> • This is normal. These switches are deactivated, as they are a part of the Switch Test. Refer to Section 3, Chapter 2, GO TO DIAGNOSTICS MENU, Switch Test.
Can't move selection of <i>Icon</i> with the Left and/or Right Flipper Buttons .	<ul style="list-style-type: none"> • Check the Flipper Buttons for loose connections or bad Ground and refer to Section 5, Chapter 2, Playfield Wiring, #-Flipper Circuit Wiring Diagram. • This is normal <i>only</i> in Diagnostic's Switch & Active Switch Tests (see previous Problem).
Some <i>Icons</i> appear non-functional in the MENU or missing.	<ul style="list-style-type: none"> • Some functionality of the Service Menu may not have been completed during development. If exists, it should only be a non-critical function, such as the "HELP" <i>Icon</i>, which will explain the usage of icons. When completed, a software update will correct the problem. Software updates are announced via Service Bulletins (if critical) and on our website http://www.sternpinball.com/GAME-code.shtml; view the Game Code Library Message Board Marquee or click Previous Messages for past announcements.
In COIL TEST MENU , the coils and flashlamps <i>do not</i> fire after pressing the Black [SELECT] Button .	<ul style="list-style-type: none"> • Ensure the POWER INTERLOCK SWITCH is pulled out (see the start of this Chapter).
In the SERVICE MENU , the volume cannot be adjusted with either of the Red Buttons .	<ul style="list-style-type: none"> • The Volume adjustment can only be made when in the Attract Mode (see the start of this Chapter).
In the SERVICE MENU , the display seems to lock up, or the Help Display appears to be non-functional.	<ul style="list-style-type: none"> • If you cannot clear the situation by exiting back one Menu, exit completely out of the SERVICE MENU, and re-enter. If the problem persists, call Technical Support for additional help.

Sec. 3: ...Menu Intro.

IF YOU NOTE ANY OTHER PROBLEMS or HAVE ANY SYMPTOMS NOT DESCRIBED ABOVE, PLEASE CALL TECHNICAL SUPPORT 800-542-5377 (708-345-7700 OPTION #1), SO WE MAY ASSIST YOU.





To initiate, from the **MAIN MENU**, select the "DIAG" *Icon*. The **DIAGNOSTICS MENU** provides tests for switches, coils, flash lamps, lamps, sounds and dots in the Dot Matrix Display. Each feature may be tested manually or automatically after entering the **SERVICE MENU** (see Section 3, Chapter 1, Service Menu Introduction). The [**CYCLING COIL TEST**] / [**FLASH LAMP TEST**] may be used for a quick verification of automatic test functions. The [**SWITCH TEST**] / [**SINGLE COIL TEST**] / [**SINGLE LAMP TEST**] / [**ALL LAMPS TEST**] / [**ROW LAMPS TEST**] / [**COLUMN LAMPS TEST**] / [**FLASH LAMP TEST**] may be used for troubleshooting.

All **DIAGNOSTICS MENU** *Icons* and there usages are explained throughout this chapter in the same order as seen in the Dot Matrix Display. **NOTE:** Depending on Game Type, Version, selections made, Dip Switch settings, location and/or areas, some *Icons* may appear non-functional or may not appear at all. Some *Icons* change depending on selections (e.g. Selecting and activating the "STRT" *Icon* [Start Tournament] will be replaced with the "STOP" *Icon* [Stop Tournament]). **Icons and/or functions, order and operation are subject to change.**

In displays where changes can be made or to perform a function, use the **GREEN Button** to go [**BACK**], exit or escape, the **RED Buttons** to [**</-**] MOVE BACK / LEFT / DECREASE / [**+/>**] MOVE FORWARD / RIGHT / INCREASE a value or setting, and the **BLACK Button** to [**SELECT**] next or as "OK / ENTER / ENERGIZE."

Important: Upon **Power-Up** (Game CPU Reset) or opening the **Coin Door** watch the **Display** for any **Alerts**.*



This **audible / visual alert display** is shown when the **50V / 20V Power** is disabled (by opening the **Coin Door**). **PULL OUT THE INTERLOCK SWITCH ONLY WHILE IN THE SERVICE MENU FOR COIL OR SWITCH TESTING & BURN-IN WHEN THE COIN DOOR IS REQUIRED TO STAY OPEN FOR SERVICE BUTTON USE!** Pulling out the Power Interlock Switch or

pressing the 'escape' **Green [BACK] Button** will remove the alert display. Initial display presentation is accompanied by 3 audible tones (the bright display warning will go dim after approximately 30 seconds).



This **alert display** is shown momentarily during **Game Mode** or **Power-Up** to alert the operator of a device malfunction (device or mechanism doesn't energize or is energized repeatedly).

OPERATOR ALERT! works by monitoring any *switch activated device* that has the potential to trap a ball when disabled (e.g. in the Shooter Lane, Scoop or Eject Holes, etc.). This alert can

also appear if a switch associated with a device (e.g. Ball Trough, Auto Plunger, etc.) is stuck closed (caused by a switch jam or stuck ball); the game will activate the device a predetermined number of times and if the problem is still detected, this device or switch will be noted in **Switch Alerts** (next page) and/or **Technician Alerts** (Page 18).



Upon entering the **SERVICE MENU**, if an asterisk " * " is displayed after the words "SERVICE MENU," the game has detected possible faulty devices, switches and/or missing pinballs. Press the either of the **Red Buttons** (short-cut to the **TECHNICIAN ALERTS MENU**) or continue into the **SERVICE MENU** (press the **Black Button** again), select the "DIAG" *Icon* and "TECH" *Icon* for the **Technician Alerts** information (Page 18).



CAUTION! Remove all pinballs from the Ball Trough prior to lifting the playfield to it's full upright position for servicing. **PULL OUT** the **Power Interlock Switch** for operation. To eject pinballs, select the "DIAG" *Icon* from the **MAIN MENU** to enter the **DIAGNOSTICS MENU**. Select the "CLR" *Icon* to enter the **BALL TROUGH TEST MENU**. Press the **Black [SELECT] Button**. To return to the **DIAGNOSTICS MENU**, press the **Green [BACK] Button**. This feature also useful to retrieve a pinball for game testing in **Switch** or **Coil Tests**.



Go To Switch Menu

To initiate, from the **DIAGNOSTICS MENU**, select the "SW" *Icon*. Switches are configured in an 4 X 16 Matrix of Rows [Switch Drives] and Columns [Sw. Returns] with up to **64** possible switches. Dedicated Switches are configured in a 2 X 16 Matrix of Rows [Dedicated Sw. Drives / Ground] and Column [Ded. Switch Returns] with up to **32** possible dedicated switches (*includes the 8 dip switch positions*). The **SWITCH TEST MENU** consists of three (3) parts: **Switch & Active Switch Tests** and **Switch Alerts** to test *all* switches.

Reminder: The **Flipper & Start Buttons** (part of Switch Tests) are temporarily disabled as **Service Menu Navigation Buttons** during these test(s) so they can be tested and shown on-screen. Pressing the **Green [BACK] Button** (Dedicated Switch D-21), Light Green-Black / Black (GND), will exit **Switch Test** or **Active Switch Test**.



Switch Test

To initiate, from the **SWITCH MENU**, select the "TEST" *Icon*. Ensure the **Power Interlock Switch** is pulled out if testing with the Coin Door open and the activation of coils is required. Upon entering **Switch Test**, you will notice that some switches are already indicated as closed. In the examples, the 4-Ball Trough Switches **#18, #19, #20 & #21** are shown closed (*pinballs at rest in the ball trough*), along with the Flipper E.O.S. Dedicated Switches **D-10 & D-12** (End-of-Stroke Switches are 'normally closed'). If the game has more flippers with E.O.S. Dedicated Switches, CPU Dip Switch Setting *other than 1-8 OFF* or switches stuck closed, more dots will be indicated (*enter Active Switch Test to reveal the names*).

In **Switch Test**, close each switch and observe the display (*switch closure is accompanied by a short audible tone*). In the example, the **Black [SELECT] Button** Dedicated Switch **D-24** is pressed. The Dot Matrix Display will light up (*highlight*) the corresponding dot in the on-screen matrix, display the *switch name, switch number and the Switch Drive / Return wire colors*. When not closing a switch, the display indicates **NONE** and the last switch number closure. For the Switch Matrix Grid and Dedicated Switch Grid, see **Find-It-In-Front: Dr. Pinball, DR. 4** or escape out of this test and enter **Active Switch Test** (*described below*) to view the names of the switches closed. **Note:** Pressing the **Green [BACK] Button** (Ded. Switch D-21), Lt. Green-Black / Black (GND), will exit the **Switch Test**.

CAUTION! COIL MECHANISMS WHEN ACTIVATED HAVE FAST MOVING PARTS! While performing **Switch Test** with the Coin Door closed or open (*with the Power Interlock Switch is pulled out*), **DO NOT USE YOUR FINGER** to test switches which are associated with a coil mechanism such as a Vertical Up-Kicker (*hole with a switch*), Slingshots, Bumpers, etc..



Active Switch Test

To initiate, from the **SWITCH MENU**, select the "ACT" *Icon*. In **Active Switch Test**, if any switches are stuck closed (*or normally closed from the presence of pinball(s) as in the Ball Trough*), the display will flash the corresponding dot(s) in the on-screen matrix, display the *name and the Switch Drive / Return wire colors*. If more than one switch is closed, the switch information will change with each switch. This cycle continues until all switches are cleared or until **Active Switch Test** is exited. In the example, the **Black [SELECT] Button** Dedicated Switch **D-24** is pressed and held down. The display will cycle and flash each dot, naming each switch which is closed. To determine the *switch number*, compare the highlighted dot to the same position in the Switch Matrix Grid, see **Find-It-In-Front: Dr. Pinball, DR. 4**.



Switch Alerts

To initiate, from the **SWITCH MENU**, select the "ALRT" *Icon*. In **Switch Alerts Menu**, possible inoperable switches are marked with an "X" (OUT OF SERVICE). Mark switches **IN** or **OUT OF SERVICE** by pressing the **Black Button** while the intended switch is highlighted and change with either of the **Red Buttons**. Switches which are determined as "OUT OF SERVICE" by the game or manually, will be automatically marked as "IN SERVICE" as soon as the game determines a valid switch closure (*after adjusting, fixing or replacing the switch, then testing/actuating the switch*). **Note:** A **Factory Reset** will also put the switch back "IN SERVICE" in which the game will need to redetermine if the switch should be marked **OUT OF SERVICE**.

Upon entering **Switch Test**, you will notice that some switches are already indicated as 'closed'.



D-24 position is highlighted and accompanied by a short audible tone when pressed.



After pressing the switch (to make it close), the display will indicate the last switch number.



Typical Switch Wiring & Schematic

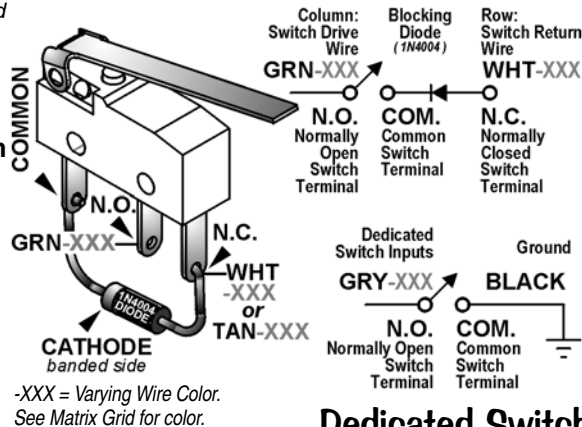

Dedicated Switch Schematic

... D-24 is held down. The display will cycle and flash each dot, naming each switch ... closed.





Go To Coil Menu

To initiate, from the **DIAGNOSTICS MENU**, select the "COIL" *Icon*. Coils **#01 – #16** are typically High Current Coils (*although Low Current Coils may be used in these positions & will be noted*). Coils **#17 – #32** are typically Low Current Coils. Flash Lamps are typically used in positions **#25 – #32** (*although Flash Lamps may be used in any position and will be noted*). Auxiliary Coils may be used in positions **#33 – #35**.

Remember, use the **GREEN Button** to go [**BACK**], exit or escape, the **RED Buttons** to [**</-**] GO BACK [**+ / >**] GO FORWARD, and the **BLACK Button** to [**SELECT**] ENERGIZE the coil (*solenoid*) or flash lamp.



Single Coil Test

To initiate, from the **COIL MENU**, select the "TEST" *Icon*. Ensure the **Power Interlock Switch** is pulled out if testing with the Coin Door open. Upon entering

Single Coil Test, you will notice the #1 coil is shown. The Dot Matrix Display will indicate the *coil or flash lamp name, coil (solenoid) or flash lamp number and the Coil or Flash Lamp Power Line / Drive Transistor Control Line wire colors*. To determine the "Pin-Outs" from the I/O Power Driver Board, the Coil Voltage Gauge-Turns (*e.g. 23-800*) or lamp type (*e.g. #89 or #906 Bulb*), view the Coils Detailed Chart Table, see **Find-It-In-Front: Dr. Pinball, DR. ③** or for more on troubleshooting and diagnosing, see Section 5.



Cycling Coil Test

To initiate, from the **COIL MENU**, select the "CYC" *Icon*. Ensure the **Power Interlock Switch** is pulled out if testing with the Coin Door open. The test pulses each regular coil or flash lamp sequentially (*cycling*) on the Playfield and in the Backbox (*if coils or flash lamps are used*). The Dot Matrix Display indicates the same information you will find in **Single Coil Test**.



Typical Coil Wiring & Schematic

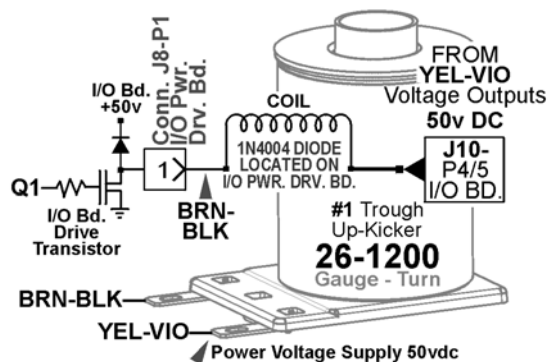

Go To Flash Lamps Menu

To initiate, from the **DIAGNOSTICS MENU**, select the "FLASH" *Icon*. The two tests allows the technician to easily spot any burned-out flash lamps and replace them. Unlike **Single Coil Test**, which tests *all* coil (*solenoids*), including flash lamps, **Single** and **Cycling Flash Lamp Tests**, test only the flash lamps used in the game. Flash Lamps are typically used in positions **#25 – #32** (*although Flash Lamps may be used in any position and will be noted*).

Remember, use the **GREEN Button** to go [**BACK**], exit or escape, the **RED Buttons** to [**</-**] GO BACK / [**+ / >**] GO FORWARD, and the **BLACK Button** to [**SELECT**] ENERGIZE the flash lamp.



Single Flash Lamp Test

To initiate, from the **FLASH LAMPS MENU**, select the "TEST" *Icon*. Ensure the **Power Interlock Switch** is pulled out if testing with the Coin Door open. Upon entering **Single Flash Lamp Test**, you will notice the first Flash Lamp is shown. The Dot Matrix Display will indicate the *flash lamp name, flash lamp number and the Flash Lamp Power Line / Drive Transistor Control Line wire colors*. To determine the "Pin-Outs" from the I/O Power Driver Board or lamp type (*e.g. #89 or #906 Bulb*), view the Coils Detailed Chart Table, see **Find-It-In-Front: Dr. Pinball, DR. ③** or for more on troubleshooting and diagnosing, see Section 5.



Cycling Flash Lamp Test

To initiate, from the **FLASH LAMPS MENU**, select the "CYC" *Icon*. Ensure the **Power Interlock Switch** is pulled out if testing with the Coin Door open. The test pulses each flash lamp sequentially (*cycling*) on the Playfield and in the Backbox (*if flash lamps are used*). The Dot Matrix Display indicates the same information you will find in **Single Flash Lamp Test**.



Bulb Types used for Flash Lamps

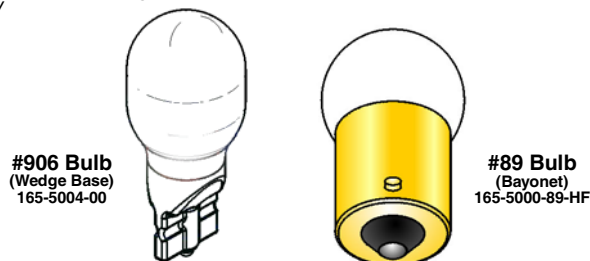



Go To Lamp Menu

To initiate, from the **DIAGNOSTICS MENU**, select the "LAMP" *Icon*. Controlled lamps are configured in and 8 X 10 Matrix of Rows [Lamp Returns / Ground] and Columns [Lamp Drives / 18VDC] with up to 80 lamps possible. The **LAMP TEST MENU** consists of five (5) parts: **Single Lamp Test**, **Test All Lamps**, **Row Lamps Test**, **Column Lamps Test** and **Ordered Lamps Test*** to test *all* lamps.

Remember, use the **GREEN Button** to go [**BACK**], exit or escape, the **RED Buttons** to [**</->**] GO BACK / LEFT / [**+/>**] GO FORWARD / RIGHT, and the **BLACK Button** to [**SELECT**] next or as "OK / ENTER."

Upon entering **Single Lamp Test**, ... the #1 lamp is shown. Display will light up ... the dot ... ▶



Single Lamp Test

To initiate, from the **LAMP MENU**, select the "ONE" *Icon*. As each lamp is selected, the lamp will light at it's location on the playfield as well as the Dot Matrix

Display. Upon entering **Single Lamp Test**, you will notice the #1 lamp is shown. The Dot Matrix Display will light up (*highlight*) the corresponding *dot* in the on-screen matrix, display the *lamp name*, *lamp number* and the *Lamp Return / Drive wire colors*. For the Lamp Matrix Grid, see **Find-it-in-Front: Dr. Pinball, DR. Ⓞ**, at the beginning section of this Service Game Manual.



Upon entering **All Lamps Test**, ... the Dot Matrix Display is flashing "ALL LAMPS ON" ... ▶



All Lamps Test

To initiate, from the **LAMP MENU**, select the "ALL" *Icon*. Upon entering **All Lamps Test**, you will notice the Dot Matrix Display is flashing **ALL LAMPS ON** and the

lamps on the playfield will be lit, alternating between the rows in the Lamp Matrix Grid. The Dot Matrix Display will light up (*highlight*) all of the *dots* in the on-screen matrix.



Upon entering **Row Lamps Test**, you will notice the #1 lamp row is shown. ▶



Row Lamps Test

To initiate, from the **LAMP MENU**, select the "ROW" *Icon*. As each lamp row is selected, the lamps in the row will light on the playfield as well as the Dot Matrix

Display. Upon entering **Row Lamps Test**, you will notice the #1 lamp row is shown. The Dot Matrix Display will light up (*highlight*) the corresponding row of *dots* in the on-screen matrix, display the *lamp row number*, the *Lamp Return wire colors*, the *I/O PCB Connector* and *transistor number*.



Upon entering **Column Lamps Test**, you will notice the #1 lamp column is shown. ▶



Column Lamps Test

To initiate, from the **LAMP MENU**, select the "COL" *Icon*. As each lamp column is selected, the lamps in the column will light on the playfield as well as the Dot

Matrix Display. Upon entering **Column Lamps Test**, you will notice the #1 lamp column is shown. The Dot Matrix Display will light up (*highlight*) the corresponding row of *dots* in the on-screen matrix, display the *lamp column number*, the *Lamp Drive (18VDC) wire colors*, the *I/O PCB Connector* and *IC number*.



Sec. 3: ... Diagnostics

Bulb Types used for Control Lamps

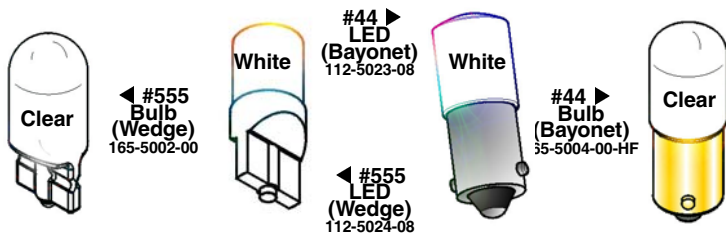

* If not required in this game, *Icon* will not be shown.



Ordered Lamps Test

To initiate, from the **LAMP MENU**, select the "ORD" *Icon*. If required, this *Icon* will appear in the **LAMP MENU**. Identical to **Single Lamp Test**, however, the lamps lit are not in the Lamp Matrix numeric order, but ordered or arranged in separate localized grouping(s) for easier lamp checking.

Typical Lamp Schematic & Wiring

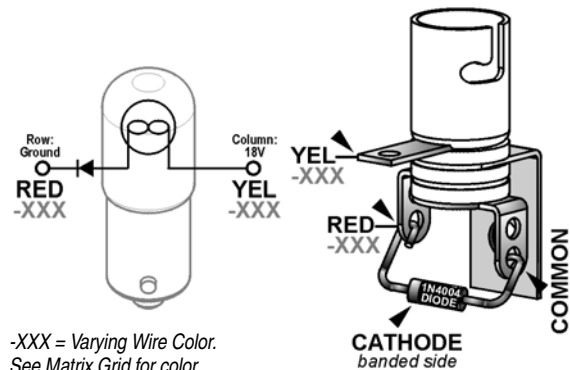

-XXX = Varying Wire Color. See Matrix Grid for color.



Donkey Motor (Shrek) Test

To initiate, from the **DIAGNOSTICS MENU**, select the " 'S' " *Icon*. Ensure the Power Interlock Switch is pulled out when testing with the Coin Door open. This Menu is provided to allow the technician a simple method of properly testing the Donkey Stepper Motor & Controller PCB Drive (Coil #20) which will not appear in the normal **SINGLE COIL TEST MENU** or **CYCLING COIL TEST MENU** (as described on Page 15).

DONKEY MOTOR TEST
PRESS 'SELECT' TO ACTIVATE
PRESS 'BACK' TO EXIT

DONKEY MOTOR TEST
PRESS 'SELECT' TO CANCEL
PRESS 'BACK' TO EXIT

If the Donkey character came out of alignment (doesn't turn towards the Donkey Mini-Pinball Machine when this feature is activated), this test will align the Donkey in the correct position.

First ensure the character is not loose and the **Set Screw** is correctly in place to secure the **Character Platform** onto the motor shaft adaptor. The **Set Screw** should tighten up against the " flat " of the Adaptor on the Motor Shaft (see Section 4, Chapter 2, Item 4, **Donkey & Motor Assembly**, on Page 87).

To activate the Stepper Motor Controller PCB (Coil #20), from the **DONKEY MOTOR TEST MENU**, press the **BLACK [SELECT] Button** and let it run a few times. It will pulse the Stepper Motor enough to adjust even the most extreme out-of-alignment scenario; so no matter where the **Set Screw** is at, it will stop against the **raised portion** of the **Motor Mounting Bracket**. Then the Stepper Motor Controller PCB will pulse the Stepper Motor in the opposite direction to align the donkey properly.

View the Coils Detailed Chart Table on Page **DR. 8 (Find-It-In-Front)** or Section 5, Pages **96-97 & 142**, for more technical information on the Coil Drive (wire colors) & the Stepper Controller PCB (520-5261-00).

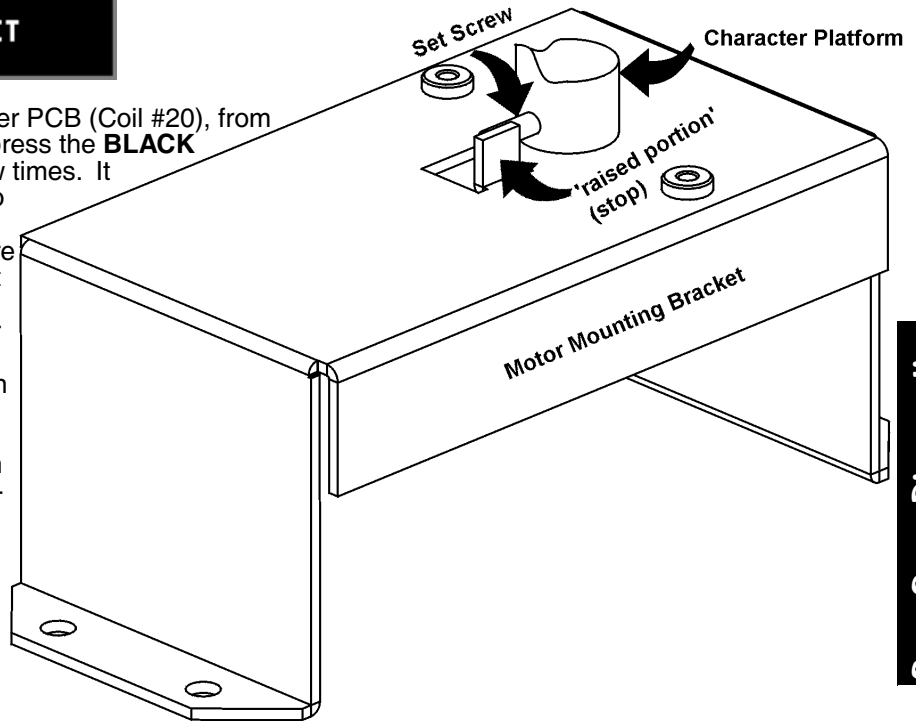

Sec. 3: ... Diagnostics



Ball Trough Test

To initiate, from the **DIAGNOSTICS MENU**, select the "CLR" *Icon*. Ensure the **Power Interlock Switch** is pulled out if testing with the Coin Door open. This Menu is provided to allow the technician a simple method of removing the balls from the trough and also, to test functionality of the trough, ensuring proper trough operation. Upon entering **Ball Trough Test**, you will notice that four switches are already indicated as closed. In the example, the 4-Ball Trough Switches #18, #19, #20 & #21 are shown closed (pinballs at rest in the ball trough). To return to the **DIAGNOSTICS MENU**, press the **Green [BACK] Button**.



Press the **Black [SELECT] Button** to eject the ball in the first position Switch #21 (VUK OPTO Trough #1 (R)). Simultaneously, the Dot Matrix Display and the playfield will eject the ball to the Trough Up-Kicker, eject from the Trough Up-Kicker into the Shooter Lane, momentarily closing Switch #23 (Shooter Lane), and is ejected onto the playfield where the technician can easily retrieve the pinball or allow the ball(s) to re-enter the trough to continue **Ball Trough Test**. The Dot Matrix Display indicates Switch #18 (4-Ball Trough #4 (L)) as open as the remaining three (3) pinballs shift over one (1) position to the right. If the technician allows the ejected pinball to reenter the ball trough, the Dot Matrix Display will indicate Switch #18 as closed. **REMINDER:** Switch #22 is the stacking OPTO switch; If more than five (5) pinballs are used, the additional switches will be noted. In this game, **four (4)** pinballs are used and required for proper operation.



CAUTION! Continuous use off the above test may overheat the Trough Up-Kicker Coil.



Technician Alerts

To initiate, from the **DIAGNOSTICS MENU**, select the "TECH" *Icon*. This Menu is provided to show any switch or solenoid problems and/or missing pinballs. If upon entering the **SERVICE MENU** the display indicated an asterisk (*) and "USE -/+ TO VIEW TECH. ALERTS", alerts are present.



After pressing either **Red [</-] / [+ / >] Button** or selecting this *Icon* in the **DIAGNOSTICS MENU**, the display will indicate the alert(s). If there are 2 alerts present, the display will indicate (1/2) with the 1st alert on the display. Press the **Red [+ / >] Button** to view the second alert (2/2). The second number in the parenthesis () after the slash (/) indicates how many alerts are present. Refer to the start of this chapter (*bottom of Page 13*) regarding "Upon entering the **SERVICE MENU ***" indication and to **SWITCH ALERTS** (*Page 14*). To return to the **DIAGNOSTICS MENU**, press the **Green [BACK] Button**. **Note:** While in this menu, an option may be present to jump (short-cut) to the appropriate Testing Menu (e.g. *Coil Test, Switch Test, Game Specific Test or Ticket Dispenser Test, if installed*).

NOTE ON SWITCH DETECTION : During game play, activation of switches are continuously monitored. For a switch to be determined as inoperable or **OUT OF SERVICE**, up to twenty games or so must be played for a switch to be automatically marked as **OUT OF SERVICE**. In programming, if a switch is determined to be faulty, game play is compensated. Switches noted as **OUT OF SERVICE** are determined to be stuck closed or open depending on switch usage. Free up the switch actuator, adjust or replace, if necessary. Performing a valid switch closure will put the switch back "IN SERVICE."

Determination of switch usage can be checked in **Audits** (*review Section 3, Chapter 3, GO TO AUDITS MENU*). Find the associated Audit with the switch in question and check usage; compare the numbers to commonly used switches. After any switch is checked and repaired or replaced, it's suggested to test the switch in the **Switch Test** or **Single Coil Test** (*reviewed earlier in this chapter, Pages 14-15*) where the associated coil to the switch can be tested as well. After correcting the problem, the switch will marked "IN SERVICE" and the switch is again monitored as specified above. *Only you can determine if a switch marked OUT OF SERVICE is actually inoperable, or if it is just not getting actuated during game play.*

NOTE ON PINBALL DETECTION : While in **TECHNICIAN ALERTS MENU**, if the following is displayed, the game has detected one (1) or more pinball(s) missing and has compensated for the lost pinball(s) to provide normal game play.



During game play, a pinball can get trapped or stuck. If after approximately 15 seconds of inactivity or "no scoring," **Ball Search** is started. **Note:** *If the pinball is in the Plunger Lane or "held" on the flipper, no Ball Search will be performed.* The game will perform one **Ball Search** in an attempt to "find" or free-up the pinball.

If the game does not see a switch closure (*indicating the pinball has not been found*), the Dot Matrix Display may indicate [**LOCATING PINBALLS PLEASE WAIT ...**], during which **Ball Search** will continue until the timer runs out (*this feature will not happen if the game is in Competition Mode; Ball Search will continue until the pinball is found, unstuck and/or replaced manually*). The display will momentarily acknowledge the missing pinball(s). The game will provide another pinball into play and will compensate for the lost pinball. Game play will appear normal.

Note: *This detection and compensation will happen with every pinball, if each suffers the same fate of a ball trap. If all balls get trapped, the game cannot be played or started until the situation is rectified.*

Important: *Determine where the pinball is! Do not add pinball(s) until it is determined the pinball(s) are indeed missing and not just stuck. The most common places for a pinball to be stuck is in device holes (ejects and VUKs) or ball troughs. Determine that all devices are functionally properly. Check around plastic pieces and ramps to see if the pinball got jammed or stuck.*

When the found pinball or a replacement pinball is added to the Ball Trough, the **Technican Alert** will immediately clear and will then indicate any remaining alerts (*if present*) or **NO TECHNICIAN ALERTS**.

Enter the **BALL TROUGH TEST** (*review the previous page*) to cycle the pinballs and to check proper switch and coil operation. *If a pinball was added, and the originally stuck pinball has freed itself at a later time, the game will not operate correctly.*

NOTE ON DEVICE MALFUNCTION : While in **TECHNICIAN ALERTS MENU**, if the following is displayed, the game has detected a "device malfunction." Check the device indicated (*coil and/or switch*).





Knocker Test

To initiate, from the **DIAGNOSTICS MENU**, select the "KNO-CKER" *Icon*. The digitally mastered "Knocker" is sounded. The *knocker sound* is used to alert the player if he/she has received a special, replay or a credit from the Match Award feature. Press the **Black [SELECT] Button** to activate the knocker. To return to the **DIAGNOSTICS MENU**, press the **Green [BACK] Button**.

FACTOID: *The knocker got it's name from the 'original knocker' (20th century pinball games), which used a coil and when energized (fired), the plunger would strike a wood panel inside the cabinet.*



Sound / Speaker Test

To initiate, from the **DIAGNOSTICS MENU**, select the "SPKR" *Icon*. This system produces true digital stereo sound from Backbox & Cabinet Speakers or "Mono" on the Cabinet Speaker (*when used by itself*). This Menu is provided to allow the technician a simple method of testing the speakers if rewired or replaced.

Upon entering **Sound / Speaker Test**, you will notice the Dot Matrix Display indicating the first option of *available music and/or sound* in this test. Press the **Red [+ / >] Button** to cycle through the *available music and/or sounds*, and press the **Black [SELECT] Button** to play the option shown in the Dot Matrix Display. Press the **Green [BACK] Button** to exit.

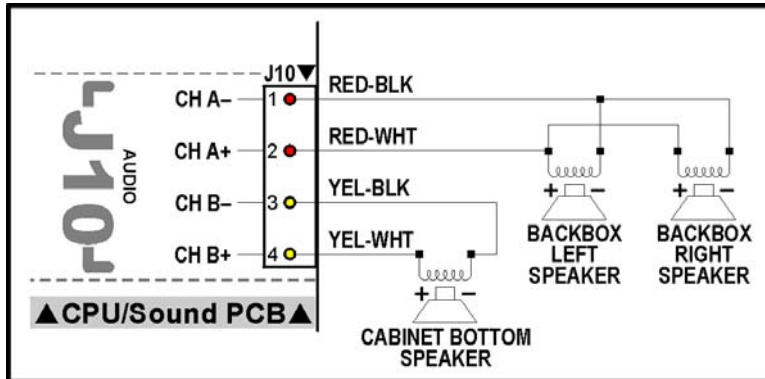

Speaker Phase Testing

Connections to each of speakers are polarized and each must be connected appropriately for the best quality sound. If one speaker has the positive and negative connections reversed with respect to the other one, bass frequencies will not be produced properly and the overall sound quality will be poor. To test for proper speaker phasing, use the **Sound / Speaker Test** to cycle through the available music and sound. If the sound is not balanced or doesn't sound correct, check the speaker wiring.

1. Check each speaker for polarity markings. If the speakers have polarity markings, verify that the Backbox Speaker's **RED-BLK** Wires and the Cabinet Speaker **YEL-BLK** Wire(s) are connected to the negative (-) terminal.
2. Disconnect the speaker output **Connector J10 (AUDIO)** from the CPU / Sound PCB (*in the Backbox*) and connect a 1.5-volt battery across each speaker pair one at a time while observing the speakers.
3. Make sure the positive (+) battery terminal is connected to the positive lead [J10, Pin-2, **CH A+**] (**RED-WHT**) or [J10, Pin-4, **CH B+**] (**YEL-WHT**) each time. As the connection is made, check speaker cone movement; proper connections are indicated by outward movement.



Begin Burn-In

To initiate, from the **DIAGNOSTICS MENU**, select the "BURN" *Icon*. After selecting this *Icon*, the **Burn-In Test** will start. Ensure the **Power Interlock Switch** is pulled out if testing with the Coin Door open (*required for coil function*). Upon entering **Burn-In Test**, the game will exercise all CPU I/O Functions: **Dot Matrix Display Test**, **Coil Cycling Testing**, **All Lamps Test** and **Sound / Speaker Test**. Press the **Green [BACK] Button**, to pause and to view the cumulative Burn-In minutes. Press the **Green [BACK] Button** again to return to the **DIAGNOSTICS MENU**.

Note: *To reset Burn-In minutes back to 0:00, see Section 3, Chapter 5, GO TO RESET MENU (via the UTILITIES MENU), Reset Factory Settings. CAUTION: Performing a FACTORY RESET will reset all other information as well (read Section 3, Chapter 5, GO TO UTILITIES MENU, for more information).*



Dot Matrix Test

To initiate, from the **DIAGNOSTICS MENU**, select the "DOT TEST" *Icon*. After selecting this *Icon* the **Dot Matrix Test** immediately begins. The Dot Matrix Display will immediately and continuously illuminate and cycle each of the **5 Tests for 1 pass each**. To return to the **DIAGNOSTICS MENU**, press the **Green [BACK] Button**.

Test 1

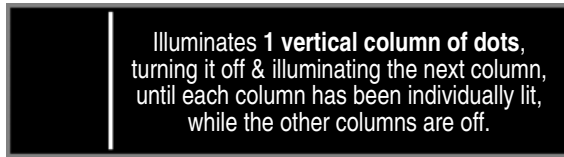

Test 2

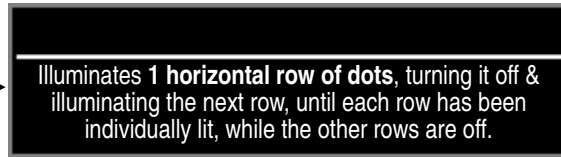

Test 3

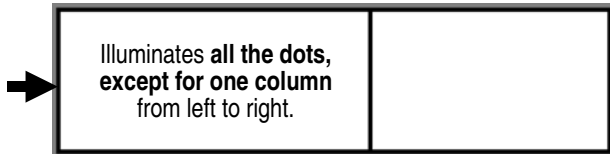

Test 4

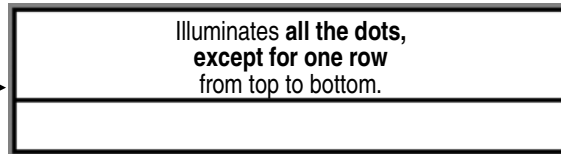

Test 5



Test 1

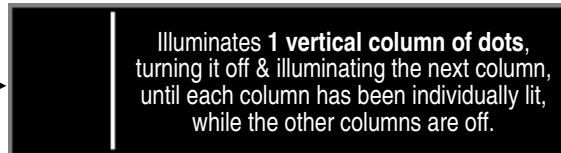

Sec. 3: ... Diagnostics



Ticket Dispenser Test

To initiate, from the **DIAGNOSTICS MENU**, select the "TIX" *Icon*. This Menu (*Icon*) will only appear if **Standard Adjustment 56, Ticket Dispenser**, is set to **YES** (Default = **NO***). ***Note:** Some games shipped from the factory with a unique Dip Switch Setting will default to **YES**. To view and/or change your setting, see **Section 3, Chapter 4, GO TO ADJUSTMENTS MENU**. Please remember, if you install an optional Ticket Dispenser, and your default setting is "NO," you will have to reset it back to "YES" if a **Factory Reset** is performed.

After selecting this *Icon*, the **Ticket Dispenser Test** will start. With the Ticket Dispenser properly installed, manually feed your tickets into the dispenser. The dispenser will activate and pull in the first ticket. Press the **Black [SELECT] Button** (which energizes Coil #35, Aux 3: Switched Ground) to advance a ticket. Feeding your Tickets into the dispenser works because Coil #33, Aux 1: Ticket Advance (Enable) is always 'energized'. With a Ticket Meter installed, as one Ticket Passes through the Ticket Dispenser, one 'click' is fired to the Meter (Coil #34, Aux 2: Ticket Meter) for each ticket passing through. Dedicated Switch **D-19, Ticket Notch**, will also be indicated on-screen (*in combination with a audible sound*) as "closing" as the notch between the tickets passes through. In this test you can clear ticket jams and check and/or clear tickets in Escrow, if necessary. To return to the **DIAGNOSTICS MENU**, press the **Green [BACK] Button**.



To initiate, from the **MAIN MENU**, select the "AUD" *Icon*. The **AUDITS MENU** provides **156*** Audits for accounting purposes and for evaluation of *Game Programming*. The Audits are divided into 4 groups: • **Earnings Audits [#1 – #13]**, • **Standard Audits [#1 – #59]**, • **Feature Audits (Programming Use Only) [#1 – #70]** and • **Tournament Audits [#1 – #14]**, "T AUD" *Icon* provided as an alternate access to Tournament Audits (*if data is available). For more information on the **TOURNAMENT MENU**, review *Section 3, Chapter 6, GO TO TOURNAMENT MENU*). Try the "DUMP AUDITS TO USB" feature to create a text file of your audits. Don't forget to set the **DATE & TIME** in the **UTILITIES MENU**. See *Sec. 3, Chp. 5, GO TO UTILITIES MENU*, for more information.

Audits which are named **Proprietary** are also for **Future Expansion** or **Programming**. Game code may get upgraded during production; compare all Audits in the Dot Matrix Display with the manual and make any corrections, as necessary. Audits are subject to change (*with or without notice*).

All **AUDITS MENU** *Icons* and their usages are explained throughout this chapter in the same order as seen in the Dot Matrix Display. **NOTE:** Depending on Game Type, Version, selections made, Dip Switch settings, location and/or areas, some *Icons* may appear non-functional or may not appear at all. **Icons and/or functions, order and operation are subject to change.**

In displays where changes can be made or to perform a function, use the **GREEN Button** to go [**BACK**], exit or escape, the **RED Buttons** to [**</-**] MOVE BACK / LEFT / [**+ / >**] MOVE FORWARD / RIGHT to view the next audit in the group, and the **BLACK Button** to [**SELECT**] the sub-menus.



Earnings Audits [#1 – #13]

To initiate, from the **AUDITS MENU**, select the "EARN" *Icon*. The Dot Matrix Display will indicate the *audit number (in this group), audit name and the audit total or value*. The current audit will remain on the display until the next audit is viewed or when this sub-menu is exited.

- #1 **TOTAL PAID CREDITS [0]**: Total number of *Paid Credits*.
- #2 **FREE GAME PERCENTAGE [0%]**: Percentage value is 'Total Free Plays' (Standard Audit 15) divided by 'Total Plays' (Standard Audit 16).
- #3 **AVERAGE BALL TIME [0:00]**: In seconds, the average ball time is derived from the total play time divided by Standard Audit 1, Total Balls Played.
- #4 **AVERAGE GAME TIME [0:00]**: The average game time is expressed in minutes and seconds.
- #5 **COINS THROUGH LEFT SLOT [0]**: Total 'Left Coin Slot' Dedicated Switch (**D-1**) closures.
- #6 **COINS THROUGH RIGHT SLOT [0]**: Total 'Right Coin Slot' Dedicated Switch (**D-3**) closures.
- #7 **COINS THROUGH CENTER SLOT [0]**: Total 'Center Coin Slot' Dedicated Switch (**D-2**) closures.
- #8 **COINS THROUGH FOURTH SLOT**: Total '4th Coin Slot' Dedicated Switch (**D-4**) closures.
- #9 **COINS THROUGH FIFTH SLOT**: Total '5th Coin Slot' Dedicated Switch (**D-5**) closures.
- #10 **TOTAL COINS [0]**: Total amount of coins registered through all the *Coin Slots*.
- #11 **TOTAL EARNINGS [USD 0.00]**: Total cash value accumulated since the last Factory Reset occurred (review *Section 3, Chapter 5, GO TO RESET MENU* (via the **UTILITIES MENU**), **Reset Coin Audits**).
- #12 **METER CLICKS [0]**: Total number of money clicks accumulated.
Based on the country's lowest coin denomination used for the game credit.
- #13 **SOFTWARE METER [0]**: Continuing total of Meter Clicks.
This audit cannot be reset; the display shows the constant addition of Meter Clicks.



Standard Audits [#1 – #59]

To initiate, from the **AUDITS MENU**, select the "S.P.I." *Icon*. The Dot Matrix Display will indicate the *audit number (in this group)*, *audit name* and the *audit total or value*. The current audit will remain on the display until the next audit is viewed or when this sub-menu is exited.

- #1 **TOTAL BALLS PLAYED [0]**: Total number of *Regular* and *Extra Balls*.
- #2 **TOTAL EXTRA BALLS [0]**: Total number of *Extra Balls* awarded.
- #3 **EXTRA BALLS PERCENTAGE [0%]**: Percentage value is 'Total Extra Balls' (Standard Audit 2) divided by 'Total Plays' (Standard Audit 16).
- #4 **REPLAY 1 AWARDS [0]**: Total Awards (*Credits, Extra Balls or Scores*) for Level 1.
- #5 **REPLAY 2 AWARDS [0]**: Total Awards (*Credits, Extra Balls or Scores*) for Level 2.
- #6 **REPLAY 3 AWARDS [0]**: Total Awards (*Credits, Extra Balls or Scores*) for Level 3.
- #7 **REPLAY 4 AWARDS [0]**: Total Awards (*Credits, Extra Balls or Scores*) for Level 4.
- #8 **TOTAL REPLAYS [0]**: Total Awards (*Credits, Extra Balls or Scores*) for exceeding *Replay Score Levels*.
- #9 **REPLAY PERCENTAGE [0%]**: Percentage value is 'Total Replays' (Standard Audit 8) divided by 'Total Plays' (Standard Audit 16). *The percentage reflects replay total awards for exceeding replay score levels.*
- #10 **TOTAL SPECIALS [0]**: Total Awards (*Credits, Extra Balls, or Scores*) for making *Specials*.
- #11 **SPECIAL PERCENTAGE [0%]**: Percentage value is 'Total Specials' (Standard Audit 10) divided by 'Total Plays' (Standard Audit 16).
- #12 **TOTAL MATCHES [0]**: Total *Credits* awarded for matching the last two digits of the score with the *System-Generated Match Number* at the end of the game. Percentage of *Match Credits* is adjustable from 0% to 10% or OFF by Standard Adjustment 19, *Match Percentage, if enabled (review Section 3, Chapter 4, GO TO ADJUSTMENTS MENU, Standard Adjustments)*.
- #13 **HIGH SCORE AWARDS [0]**: Total Awards (*Credits, Extra Balls, or Scores*) for exceeding the High-Score-To-Date scores.
- #14 **HIGH SCORE PERCENT [0%]**: Percentage value is 'High Score Awards' (Standard Audit 13) divided by 'Total Plays' (Standard Audit 16).
- #15 **TOTAL FREE PLAYS [0]**: Total *Free Credits* for *Replays, High-Score-To-Date, Specials and Match*.
- #16 **TOTAL PLAYS [0]**: This total is derived by adding the sum of 'Total Paid Credits' (Earnings Audit 1) and 'Total Free Plays' (Standard Audit 13). *Note: Free credits are not recorded in the Audit until actually used.*
- #17 **0.0M–1.99M SCORES [00]**: Total number of games the Player's final score was between 0 and 1,999,990 points.
- #18 **2.0M–3.99M SCORES [00]**: Total number of games the Player's final score was between 2,000,000 and 3,999,990 points.
- #19 **4.0M–5.99M SCORES [00]**: Total number of games the Player's final score was between 4,000,000 and 5,999,990 points.
- #20 **6.0M–7.99M SCORES [00]**: Total number of games the Player's final score was between 6,000,000 and 7,999,990 points.
- #21 **8.0M–9.99M SCORES [00]**: Total number of games the Player's final score was between 8,000,000 and 9,999,990 points.
- #22 **10.0M–12.49M SCORES [00]**: Total number of games the Player's final score was between 10,000,000 and 12,499,990 points.
- #23 **12.5M–14.99M SCORES [00]**: Total number of games the Player's final score was between 12,500,000 and 14,499,990 points.
- #24 **15.0M–17.49M SCORES [00]**: Total number of games the Player's final score was between 15,000,000 and 17,499,990 points.
- #25 **17.50M–19.99M SCORES [00]**: Total number of games the Player's final score was between 17,500,000 and 19,999,990 points.
- #26 **20.0M–24.99M SCORES [00]**: Total number of games the Player's final score was between 20,000,000 and 24,499,990 points.
- #27 **25.0M–29.99M SCORES [00]**: Total number of games the Player's final score was between 25,000,000 and 29,999,990 points.

Standard Audits 28-59 continued on the next page.

Sec. 3: Go To Audits





Standard Audits Continued

- #28 **30.0M–39.99M SCORES [00]** : Total number of games the Player's final score was between **30,000,000** and **39,999,990** points.
- #29 **40.0M–49.99M SCORES [00]** : Total number of games the Player's final score was between **40,000,000** and **49,999,990** points.
- #30 **50.0M–74.99M SCORES [00]** : Total number of games the Player's final score was between **50,000,000** and **74,999,990** points.
- #31 **75.0M–99.99M SCORES [00]** : Total number of games the Player's final score was between **75,000,000** and **99,999,990** points.
- #32 **100.0M–149.99M SCORES [00]** : Total number of games the Player's final score was between **100,000,000** and **149,999,990** points.
- #33 **150.0+M SCORES**: Total number of games the Player's final score was **150,000,000** points and over.
- #34 **AVERAGE SCORES [00]** : This total is derived by adding the Final Score of each game to a table and dividing this sum by 'Total Plays' (Standard Audit 16).
- #35 **SERVICE CREDITS [0]** : Total 'Green [SERVICE CREDIT] Button' Dedicated Switch (**D-21**) closures in **Attract Mode** (not while in the **SERVICE MENU**). See Section 3, Chapter 1, **Service Switch X4 Set Access & Use**, for how to receive Service Credits. See Section 3, Chapter 5, **GO TO RESET MENU** (via **GO TO UTILITIES MENU**), **Reset Credits**, for how to delete credits.
- #36 **BALL SEARCH STARTED [0]** : Total number of times the game performed a *Ball Search*.
- #37 **LOST BALL FEEDS [0]** : Total number of times the game added a pinball to play when it could not find a pinball after *Ball Search* (review Section 3, Chapter 2, **GO TO DIAGNOSTICS MENU**, **Technicians Alert [Pinball Detection]**).
- #38 **LOST BALL GAME STARTS [0]** : Total number of times the game started with a pinball missing from the ball trough at the start of a game (review Section 3, Chapter 2, **GO TO DIAGNOSTICS MENU**, **Technicians Alert [Pinball Detection]**).
- #39 **LEFT DRAINS [0]** : Total 'Left Outlane' Switch (**24**) closures.
- #40 **CENTER DRAINS [0]** : Total number of times the pinball had drained when the last switch closed was not the 'Left Outlane' (**24**) or the 'Right Outlane' Switch (**29**).
- #41 **RIGHT DRAINS [0]** : Total 'Right Outlane' Switch (**29**) closures.
- #42 **TILTS [0]** : Total 'Tilt Pendulum' Dedicated Switch (**D-17**) closures.
- #43 **TOTAL BALLS SAVED [0]** : Total number of times this feature was used. This feature is adjustable from **0:01–0:15**, **AUTO** or **NO BALL SAVES** (review Section 3, Chapter 4, **GO TO ADJUSTMENTS MENU**, Standard Adjustment **48**, *Ball Save Time*). This feature is enabled at the start of each pinball and is disabled as soon as a predetermined number of switches are "closed" or the allocated time has expired.
- #44 **LEFT FLIPPER USED [0]** : Total 'Left Flipper Button' Dedicated Switch (**D-9**) closures in **Game Mode**.
- #45 **RIGHT FLIPPER USED [0]** : Total 'Right Flipper Button' Dedicated Switch (**D-11**) closures in **Game Mode**.
- #46 **0 - 1 MINUTE GAMES [0]** : Total games in which the total game time was between **0:00** and **1:00** minute.
- #47 **1 – 1.5 MINUTE GAMES [0]** : Total games where play time was between **1:00** and **1:30** minutes.
- #48 **1.5 – 2 MINUTE GAMES [0]** : Total games where play time was between **1:30** and **2:00** minutes.
- #49 **2 – 2.5 MINUTE GAMES [0]** : Total games where play time was between **2:00** and **2:30** minutes.
- #50 **2.5 – 3 MINUTE GAMES [0]** : Total games where play time was between **2:30** and **3:00** minutes.
- #51 **3 – 3.5 MINUTE GAMES [0]** : Total games where play time was between **3:00** and **3:30** minutes.
- #52 **3.5 – 4 MINUTE GAMES [0]** : Total games where play time was between **3:30** and **4:00** minutes.
- #53 **4 – 5 MINUTE GAMES [0]** : Total games where play time was between **4:00** and **5:00** minutes.
- #54 **5 – 6 MINUTE GAMES [0]** : Total games where play time was between **5:00** and **6:00** minutes.
- #55 **6 – 8 MINUTE GAMES [0]** : Total games where play time was between **6:00** and **8:00** minutes.
- #56 **8 – 10 MINUTE GAMES [0]** : Total games where play time was between **8:00** and **10:00** minutes.
- #57 **10 – 15 MINUTE GAMES [0]** : Total games where play time was between **10:00** and **15:00** minutes.
- #58 **15+ MINUTE GAMES**: Total games in which the total game time was **15:00** minutes and over.
- #59 **RECENT REPLAY PERCENT**: Percent figured with programming thresholds for a determined number of games. The % reflects replay total awards for exceeding replay score levels.



Feature Audits [#1 – #70]

To initiate, from the **AUDITS MENU**, select the "S" Icon. The Dot Matrix Display will indicate the *audit number (in this group)*, *audit name* and the *audit total or value*. The current audit will remain on the display until the next audit is viewed or when this sub-menu is exited.

Feature Audits Definition: Programming Use Only. *The proprietary information Total number of times a feature was started, awarded, lit, played and/or completed (awarded); also, the total number of Switch Closures during certain modes or features are tracked (a predetermined single/multiple variations of switch closures are used to determine the lighting and/or completion of the feature stated).*

SEE DOT MATRIX DISPLAY FOR CURRENT FEATURE AUDITS

FEATURE AUDITS [#1 – #70] ▼

Nr.	FEATURE AUDIT NAME	YOUR RESULT
1	LEFT OUTLANE	
2	RIGHT OUTLANE	
3	GINGY RETURN LANE	
4	PINOCCHIO RETURN LANE	
5	RIGHT RETURN LANE	
6	FIONA SHOTS	
7	PUSS IN BOOTS SHOTS	
8	LEFT RAMP	
9	PINOCCHIO TARGET	
10	4-BANK DROPS COMPLETED	
11	CASTLE GUARD TARGET	
12	MAGIC MIRROR SHOTS	
13	MERLIN	
14	UTURN SHOTS	
15	DONKEY SHOTS	
16	GINGY SHOTS	
17	SPINNERS	
18	SWAMP HOLE	
19	LEFT NEWTON ROLL OVER	
20	RIGHT NEWTON ROLL OVER	
21	GODMOTHER TARGET	
22	DONKEY PINBALL STARTS	
23	AVG. DONKEY PINBALL TIME	

Nr.	FEATURE AUDIT NAME	YOUR RESULT
24	MINI FIONA COMPLETES	
25	MINI (GINGY) MAN COMPLETES	
26	MINI SHREK COMPLETES	
27	MINI PUSS COMPLETES	
28	MINI CHARM (ING) COMPLETES	
29	DONKEY MULTIBALL STARTS	
30	BURP MULTIBALL STARTS	
31	REPAY YOUR DEBT STARTS	
32	MYSTERY LIT	
33	MYSTERY COLLECTED	
34	MYSTERY SPECIAL	
35	MYSTERY EXTRA BALL	
36	MYSTERY POPS AT MAX	
37	MYSTERY EXTRA BALL	
38	MYSTERY START MBALL	
39	MYSTERY HOLD BONUS	
40	MYSTERY COLLECT BONUS	
41	MYSTERY LIGHT SWAMP MODE	
42	MYSTERY SUPER	
43	MYSTERY PINOCCHIO	
44	MYSTERY POST	
45	MYSTERY PINBALL	
46	MYSTERY BIG POINTS	

Nr.	FEATURE AUDIT NAME	YOUR RESULT
47	MYSTERY BIGGER POINTS	
48	MYSTERY BONUS X	
49	MYSTERY SPOT CHARACTER	
50	MYSTERY REPAY YOUR DEBT	
51	MIRROR COLLECT VILLAINS	
52	MIRROR 3 PIGS	
53	MIRROR UN-HAPPY HOUR	
54	MIRROR ONCE UPON A TIME	
55	MIRROR DRAGON MULTIBALL	
56	BUMP SHREK	
57	BUMP GINGY	
58	BUMP FIONA	
59	BUMP PUSS	
60	BUMP CHARM	
61	BUMP DONKEY	
62	SWAMP LIT	
63	BRIDGES TO FIONA STARTED	
64	DINNER THEATRE STARTED	
65	WRESTLING MATCH STARTED	
66	COOKIE CRUMBLES STARTED	
67	OGRES ARE ONIONS STARTED	
68	DRAGON BOZO SET LIGHT	
69	DRAGON BOZO STARTS	
70	GAMES POST 2MIN GAME	

Note: Audits are subject to change (with or without notice).



Tournament Audits [#1 – #14] subject to change

"T AUD" Icon provided as an alternate access to Tournament Audits (if data is available). For more information on the **TOURNAMENT MENU**, review **Section 3, Chapter 6, GO TO TOURNAMENT MENU**.



Dump Audits To USB (Memory Stick)

To initiate, from the **USB MENU**, select the "DUMP" Icon. Follow the on-screen prompts to perform a **Data Dump (download)**. A dated text file will be created on your USB Memory Stick. *Don't forget to set the DATE & TIME first. See Section 3, Chapter 5, GO TO UTILITIES MENU, for more information.*





To initiate, from the **MAIN MENU**, select the "ADJ" *Icon*. The **ADJUSTMENTS MENU** provides **89** Adjustments to vary Game Functions to customize for your particular needs. The Adjustments are divided into 2 groups:

• **Standard Adjustments [#1 – #63]** and • **Feature Adjustments (Programming Use Only) [#1 – #26]**. For quick and easy customization of *Game Play Difficulty or Game Play Type* or how to **RESET ONLY** the Adjustments, review **Section 3, Chapter 5, GO TO INSTALLS MENU** (via the **UTILITIES MENU**). **Shortcut: Enter Custom Message** (Standard Adj. 41) and **Set Custom Pricing** (via Standard Adjustment 18, Game Pricing) can be quickly accessed via the **UTILITIES MENU**, see **Section 3, Chapter 5, GO TO UTILITIES MENU**.

Adjustments which are named **Proprietary** are also for **Future Expansion** or **Programming**. Game code may get upgraded during production; compare all Adjustments in the Dot Matrix Display with the manual and make any corrections, as necessary. Adjustments are subject to change (*with or without notice*).

All **ADJUSTMENTS MENU** *Icons* and there usages are explained throughout this chapter in the same order as seen in the Dot Matrix Display. **NOTE:** Depending on Game Type, Version, selections made, Dip Switch settings, location and/or areas, some *Adjustments* may appear non-functional or may not appear at all. **Adjustments and/or functions, order and operation are subject to change. If in doubt use the Factory Default Settings.**

In displays where changes can be made or to perform a function, use the **GREEN Button** to go [**BACK**], exit or escape, the **RED Buttons** to [**</-**] SELECT PREVIOUS [**+ / >**] SELECT NEXT when the adjustment name or setting is flashing and the **BLACK Button** to [**SELECT**] toggle between the ADJUSTMENT and SETTING.



Standard Adjustments [#1 – #63]

To initiate, from the **ADJUSTMENTS MENU**, select the "S.P.I." *Icon*. The Dot Matrix Display will indicate the *adjustment number (in this group), adjust. name, adjust. setting and comment line*. The current adjustment will remain on the display until the next adjustment is viewed or when this sub-menu is exited.

- #1 **REPLAY TYPE:** Set to **AUTO, NONE, FIXED** or **DYNAMIC**. Factory Default = **AUTO**. **AUTO & DYNAMIC** are based on the **Replay Percentage** (Standard Adjustment 2). • Select **FIXED** to give the player a **Replay Award** (Standard Adjustment 3) as the **Replay Levels** (Standard Adjustments 7-10) are reached. The **Replay Level(s)** (Standard Adjustments 7-10) will not adjust up or down. • Select **AUTO** to give the player a **Replay Award** (Standard Adjustment 3) as the **Auto Replay Start** (Standard Adjustment 5) score level is reached. This *score threshold* will automatically adjust up or down based on the **Replay Percentage** chosen (Standard Adjustment 2). The game periodically adjusts based upon the Player Base Skill Level. • Select **DYNAMIC** to give the player a **Replay Award** (Standard Adjustment 3) as the **Dynamic Replay Start** (Standard Adjustment 6) score level is reached. This *score threshold* will go down every game based on the **Replay Percentage** (Standard Adjustment 2) selected. • Select **NONE** to turn off Standard Adjustments 2-11.
- #2 **REPLAY PERCENTAGE:** Set between **01% – 50%**. Factory Default = **10%**. Adjustable only if **AUTO** or **DYNAMIC** is installed in Replay Type, Standard Adjustment 1. For [**DYNAMIC**] example, if the *score threshold* is 50,000,00 and the **Replay Percentage** selected is **10%**, every game a player does not reach the *score threshold*, the score to reach will drop by 5,000,000 (10% of 50M). This will continue every game until the *threshold score* is reached. Thus, if the score then drops to 15,000,000 after 7 games and is then achieved, the **Replay Award** (Standard Adjustment 3) is given. The original *score threshold* is added to 15,000,000 and is now 65,000,000. It will then take the same player 10 games to reach 15,000,000. *This adjustment is shown only if AUTO or DYNAMIC is installed in Replay Type* (Standard Adjustment 1).

Standard Adjustments 3-18 continued on the next page.



Standard Adjustments continued.

- #3 **REPLAY AWARD:** Set to **CREDIT**, **TICKET***, **TOKEN*** or **EXTRA BALL**. Factory Default = **CREDIT**. Set the type of award to be given to the player when the appropriate Replay Score threshold or level is achieved. If awarding a **CREDIT**, **TICKET** or **TOKEN** is prohibited in your area, select **EXTRA BALL**. *This adjustment is not shown if NONE is installed in Replay Type (Standard Adjustment 1).*
- *Note: If TICKET or TOKEN is selected, the game will require an optional Ticket or Token Dispenser and then Q24 Option (Standard Adj. 55) must be changed accordingly.*
- #4 **REPLAY LEVELS:** Set between **1 – 4** for the number of Replay Levels to be active. Factory Default = **1**. *This adjustment is not shown if NONE is installed in Replay Type (Standard Adjustment 1).*
- #5 **AUTO REPLAY START:** Set between **5,000,000 – 150,000,000** (increments of 1,000,000) for the Auto Replay Start threshold. Factory Default = **20,000,000**. *This adjustment is shown only if AUTO is installed in Replay Type (Standard Adjustment 1).*
- #6 **DYNAMIC REPLAY START:** Set between **5,000,000 – 150,000,000** (increments of 1,000,000) for the Dynamic Replay Start threshold. Factory Default = **60,000,000**. *This adjustment is shown only if DYNAMIC is installed in Replay Type (Standard Adjustment 1).*
- #7 **REPLAY LEVEL #1:** Set between **5,000,000 – 150,000,000** (increments of 1,000,000). Factory Default = **15,000,000**. Set the first or only Replay Level. *This adjustment is shown only if FIXED is installed in Replay Type (Standard Adjustment 1).*
- #8 **REPLAY LEVEL #2:** Set between **5,000,000 – 150,000,000** (increments of 1,000,000). Factory Default = **30,000,000**. Set the second Replay Level. *This adjustment is shown only if FIXED is installed in Replay Type (Standard Adjustment 1) and 2 is installed in Replay Levels (Standard Adjustment 4).*
- #9 **REPLAY LEVEL #3:** Set between **5,000,000 – 150,000,000** (increments of 1,000,000). Factory Default = **45,000,000**. Set the third Replay Level. *This adjustment is shown only if FIXED is installed in Replay Type (Standard Adjustment 1) and 3 is installed in Replay Levels (Standard Adjustment 4).*
- #10 **REPLAY LEVEL #4:** Set between **5,000,000 – 150,000,000** (increments of 1,000,000). Factory Default = **60,000,000**. Set the fourth Replay Level. *This adjustment is shown only if FIXED is installed in Replay Type (Standard Adjustment 1) and 4 is installed in Replay Levels (Standard Adjustment 4).*
- #11 **REPLAY BOOST:** Set to **YES** or **NO**. Factory Default = **YES**. When set to **YES**, while **FIXED** or **AUTO** maintains the Replay Levels, Replay Boost works as follows: If the Replay Level is 7,000,000 (regardless of the Replay Percentage), and the Player scores 20M, and receives the Replay Award, the next game the Current Replay Level is added to this base. Thus the next game, the Replay Level is 14,000,000. The Player again scores 20M. The next game the Player will need to achieve 21,000,000 to earn the Replay Award. If the Player does not achieve 21,000,000, the next game reverts back to the original 7,000,000 or the new adjusted level maintained by the Fixed or Autopercentageing Feature. *This adjustment is shown only if AUTO or FIXED is installed in Replay Type (Standard Adjustment 1).*
- #12 **SPECIAL LIMIT:** Set between **1 – 5**, **UNLIMITED** or **NO SPECIALS**. Factory Default = **1**. Set the maximum number of *Specials* that may be accumulated per game.
- #13 **SPECIAL PERCENTAGE:** Set between **1% – 50%**. Factory Default = **10%**. This adjustment allows the operator to adjust how frequently the **Special Feature** is made available to the player. *This adjustment is not shown if NO SPECIALS is installed in Special Limit (Standard Adjustment 12).*
- #14 **SPECIAL AWARD:** Set to **CREDIT**, **TICKET***, **TOKEN***, **POINTS** or **EXTRA BALL**. Factory Default = **CREDIT**. Select **EX. BALL** or **POINTS** if awarding a **CREDIT** or **TICKET / TOKEN** is prohibited in your area. *This adjustment is not shown if NO SPECIALS is installed in Special Limit (Standard Adjustment 12).*
- *Note: If TICKET or TOKEN is selected, the game will require an optional Ticket or Token Dispenser and then Q24 Option (Standard Adj. 55) must be changed accordingly.*
- #15 **FREE GAME LIMIT:** Set between **1 – 9**, **UNLIMITED** or **NO FREE GAMES**. Factory Default = **5**. Set the maximum number of *Free Games* that may be accumulated per game.
- #16 **EXTRA BALL LIMIT:** Set between **1 – 9**, **UNLIMITED** or **NO EXTRA BALLS**. Factory Default = **5**. Set the number of *Extra Balls* that may be accumulated per game.
- #17 **EXTRA BALL PERCENTAGE:** Set between **1% – 50%**. Factory Default = **25%**. This adjustment allows the operator to adjust how frequently the **Extra Ball Feature** is made available to the player. *This adjustment is not shown if NO EXTRA BALLS is installed in Extra Ball Limit (Standard Adjustment 16).*
- #18 **GAME PRICING:** There are two (2) methods available for *Coin Switch Programming*: **Standard & Custom**. Set between **AUSTRALIA 1 – UK 6** or **CUSTOM**. Factory Default = **USA 10**. *Shortcut: Set Custom Pricing and instructions, review Section 3, Chapter 5, GO TO UTILITIES MENU, Set Custom Pricing.* The appropriate Dip Switch Setting (Dip Sw. 1-8 location CPU/Sound PCB SW1) in relationship to the Pricing Scheme selected is important (*view the tables on the following pages for more information*).

Standard Adjustment 18, Game Pricing, continued on the next page.

Sec. 3: Go To Adjust.





Standard Adjustment 18, Game Pricing, continued.

USA Standard Pricing Select Table

CPU/SOUND PCB DIP SWITCH SW1 SETTING		COUNTRY SETTING OPTION(S)	COIN MECHANISMS (SWITCHES) COINS THRU ... SLOT:				PRICING SCHEME Number of Plays (Credits) for Price Amount Shown See "Appendix J" for Coin Cards Examples & Info!	Requires SPI Coin Card(s) Part Number		
Pos.	1 2 3 4 5 6 7 8	Default Highlighted	LEFT	CENTER	RIGHT	4TH				
ON		USA 1	0.25	1.00	0.25		USD // UNITED STATES DOLLAR // [\$]			
OFF	▼▼▼▼▼▼▼▼	USA 2					1/0.25	2/0.75	3/1.00	755-5400-01-Y
		USA 3					1/0.50	For USA 6 and USA 7 use: 755-5400-02-Y USA 6 Note: If player uses X4 25c quarters = 2 plays. However, \$1 bill = 3 plays!		755-5400-02-Y
		USA 4					1/0.50	3/1.50	5/2.00	755-5400-02-Y
		USA 5					1/0.50	2/1.00	3/1.50	755-5400-00-Y
		USA 6					1/0.50	2/1.00	3/\$ 1.00 Bill	Used to promote the Bill Validator.
		USA 7					1/0.50	4/1.50	6/2.00	755-5400-00-Y
		USA 8					1/0.50	3/1.00		755-5400-07-Y
		USA 9					1/1.00			755-5400-11-Y
		USA 10					1/0.75	2/1.50	3/2.00	

HIGHLIGHTED
= Factory Default

HIGHLIGHTED
= Not Shown on Coin Card

International (non-Euro) Standard Pricing Select Table

CPU/SOUND PCB DIP SWITCH SW1 SETTING		COUNTRY SETTING OPTION(S)	COIN MECHANISMS (SWITCHES) COINS THRU ... SLOT:				PRICING SCHEME Number of Plays (Credits) for Price Amount Shown See "Appendix J" for Coin Cards Examples & Info!	Requires SPI Coin Card(s) Part Number			
Pos.	1 2 3 4 5 6 7 8	Default Highlighted	LEFT	CENTER	RIGHT	4TH					
ON	▲▲▲▲	AUSTRALIA 1	0.20	1.00	2.00		AUD // AUSTRALIAN DOLLARS // [\$AUS]				
OFF	▼▼▼▼▼▼▼▼	AUSTRALIA 2					1/1.00	3/2.00	755-5406-00-Y (1 Side)		
ON	▲▲▲▲	CANADA 1 [25¢ door]	0.25	0.25	1.00	2.00	CAD // CANADIAN DOLLARS // [\$CAN]				
OFF	▼▼▼▼▼▼▼▼	CANADA 2 [dollar door]					1/0.50	2/0.75	3/1.00	755-5400-00-Y -01-Y or -02-Y	
ON	▲▲▲▲	CANADA 2 [dollar door]	1.00		2.00		1/1.00	3/2.00	755-5400-10-Y		
OFF	▼▼▼▼▼▼▼▼										
ON	▲▲▲▲	CROATIA	1	2	5		HRK // CROATIAN KUNA // [kuna]	755-5410-00-Y (2-Sided)			
OFF	▼▼▼▼▼▼▼▼						1/3	2/5			
ON	▲▲▲▲	DENMARK 1	1	5	10	20	DKK // DANISH KRONER // [Kr]	755-5402-00-Y (2-Sided)			
OFF	▼▼▼▼▼▼▼▼	DENMARK 2					1/3	2/5			
ON	▲▲▲▲	JAPAN 1	100		100		JPY // JAPANESE YEN // [¥]	755-5408-01-Y (2-Sided)			
OFF	▼▼▼▼▼▼▼▼	JAPAN 2					1/2	2/4	3/5	4/7	5/9
ON	▲▲▲▲	MIDDLE EAST	token		token		TOKEN // Middle East currency used to buy token // [TOKEN]	755-5400-06-Y (use Side 1)			
OFF	▼▼▼▼▼▼▼▼						1/1				
ON	▲▲▲▲	NEW ZEALAND 1	1		2		NZD // NEW ZEALAND DOLLAR // [\$NZD]	755-5406-00-Y (Side 2)			
OFF	▼▼▼▼▼▼▼▼	NEW ZEALAND 2					1/1	3/2			
ON	▲▲▲▲	NORWAY 1	10	5	20		NOK // NORWEGIAN KRONE // [Kr]	755-5403-01-Y (2-Sided)			
OFF	▼▼▼▼▼▼▼▼	NORWAY 2					1/10	3/20			
ON	▲▲▲▲	RUSSIA	10	5	1		RUB // RUSSIAN RUBLE // [Ruble]	755-5411-00-Y (2-Sided)			
OFF	▼▼▼▼▼▼▼▼						1/5				
ON	▲▲▲▲	SO. AFRICA 1	0.50	1.00	1.00	1.00	ZAR // SOUTH AFRICAN RAND // [R]	755-5409-01-Y (2-Sided)			
OFF	▼▼▼▼▼▼▼▼	SO. AFRICA 2					1/2.00	2/5.00			
ON	▲▲▲▲	SWEDEN 1	1	5	10		SEK // SWEDISH KRONOR // [kr]	755-5404-00-Y (2-Sided)			
OFF	▼▼▼▼▼▼▼▼	SWEDEN 2					1/10	2/15	3/20		
ON	▲▲▲▲	SWITZERLAND 1	1	2	5		CHF // SWISS FRANCS // [Sf]	755-5405-00-Y (2-Sided)			
OFF	▼▼▼▼▼▼▼▼	SWITZERLAND 2					1/1	2/2	3/3	4/4	6/5
ON	▲▲▲▲	TAIWAN	10		10		TWD // TAIWANESE DOLLAR // [TWD]	755-5412-00-Y (use Side 1)			
OFF	▼▼▼▼▼▼▼▼						1/10				
ON	▲▲▲▲	UK 1	0.10	0.50	1.00	0.20	GPB // UNITED KINGDOM POUNDS // [£]	755-5407-00-Y			
OFF	▼▼▼▼▼▼▼▼	UK 2					3/1.00	7/2.00		755-5407-01-Y*	
		UK 3					4/1.00			755-5407-01	
		UK 4					1/0.50	2/1.00	3/1.50	5/2.00	755-5407-01-Y*
		UK 5					1/0.30	2/0.60	3/0.90	4/1.00	755-5407-01
		UK 6					1/1.00	3/2.00			755-5407-01-Y*

HIGHLIGHTED = Factory Default

HIGHLIGHTED = Not Shown on Coin Card

Standard Adjustment 18, Game Pricing, continued on the next page.





Standard Adjustment 18, Game Pricing, continued.

Euro 1-12 Summary & International (Euro) Standard Pricing Select Table

CPU/SOUND PCB DIP SWITCH SW1 SETTING		COUNTRY SETTING OPTION(S)	COIN MECHANISMS (SWITCHES)				PRICING SCHEME				Requires SPI Coin Card(s) Part Number
			COINS THRU ... SLOT:				Number of Plays (Credits) for Price Amount Shown See "Appendix J" for Coin Cards Examples & Info!				
Pos.	1 2 3 4 5 6 7 8		LEFT	CENTER	RIGHT	4TH					
ON	S E E B E L O W	Euro 1	0.50	1.00	2.00	0.20	EUR // EUROPEAN UNION EUROS // € 1				755-5401-01-Y
OFF	S E T T I N G S	Euro 2					1/0.50 2/1.00 3/1.50 5/2.00				755-5401-02-Y
		Euro 3					1/0.50 3/1.00				755-5401-03-Y
		Euro 4					1/0.50 2/1.00 3/1.50 6/2.00				755-5401-04-Y
		Euro 5					1/0.50 3/1.00 4/1.50 7/2.00				755-5401-05-Y
		Euro 6					2/0.50				755-5401-06-Y
		Euro 7					1/1.00 2/2.00 3/3.00 5/4.00				755-5401-07-Y
		Euro 8					1/1.00 3/2.00				755-5401-08-Y
		Euro 9					1/1.00 2/1.50 3/2.00				755-5401-09-Y
		Euro 10					1/1.00 3/2.00 7/3.00				755-5401-10-Y
		Euro 11					1/1.00 4/2.00				755-5401-11-Y
		Euro 12					2/1.00 4/2.00 6/3.00 9/4.00				755-5401-12-Y

For a different Euro Pricing Scheme (other than Factory Default listed below), scroll through Standard Adjustment 18: Euro 1-12 or CUSTOM* for new setting (reference above Euro 1-12 Summary). Keep the Country Dip Switch Setting the same as listed below.

Sec. 3: Go To Adjust.

Pos.	1 2 3 4 5 6 7 8	Default Highlighted	EUR // EUROPEAN UNION EUROS // € 1				755-5401-09-Y	
ON	▲	AUSTRIA Euro 9	0.50	1.00	2.00	1/1.00	2/1.50	3/2.00
OFF	▼							
Pos.	1 2 3 4 5 6 7 8	Default Highlighted	EUR // EUROPEAN UNION EUROS // € 1				755-5401-01-Y	
ON	▲	BELGIUM Euro 1	0.50	1.00	2.00	1/0.50		
OFF	▼							
Pos.	1 2 3 4 5 6 7 8	Default Highlighted	EUR // EUROPEAN UNION EUROS // € 1				755-5401-08-Y	
ON	▲	FINLAND Euro 8	0.50	1.00	2.00	1/1.00	3/2.00	
OFF	▼							
Pos.	1 2 3 4 5 6 7 8	Default Highlighted	EUR // EUROPEAN UNION EUROS // € 1				755-5401-10-Y	
ON	▲	FRANCE Euro 10	0.50	1.00	2.00	1/1.00	3/2.00	7/3.00
OFF	▼							
Pos.	1 2 3 4 5 6 7 8	Default Highlighted	EUR // EUROPEAN UNION EUROS // € 1				755-5401-01-Y	
ON	▲	GERMANY 1	0.50	1.00	2.00	1/0.50		755-5401-01-Y
OFF	▼	GERMANY 2				1/0.50 2/1.00 3/1.50 5/2.00	755-5401-02-Y	
		GERMANY 3				1/0.50 2/1.00 3/1.50 6/2.00	755-5401-04-Y	
Pos.	1 2 3 4 5 6 7 8	Default Highlighted	EUR // EUROPEAN UNION EUROS // € 1				755-5401-08-Y	
ON	▲	GREECE Euro 8	0.50	1.00	2.00	1/1.00	3/2.00	
OFF	▼							
Pos.	1 2 3 4 5 6 7 8	Default Highlighted	EUR // EUROPEAN UNION EUROS // € 1				755-5401-01-Y	
ON	▲	ITALY 1	0.50		0.50	1/0.50		755-5401-01-Y
OFF	▼	ITALY 2				1/1.00	3/2.00	755-5401-08-Y
Pos.	1 2 3 4 5 6 7 8	Default Highlighted	EUR // EUROPEAN UNION EUROS // € 1				755-5401-03-Y	
ON	▲	NETHERLANDS Euro 3	0.50	1.00	2.00	1/0.50	3/1.00	
OFF	▼							
Pos.	1 2 3 4 5 6 7 8	Default Highlighted	EUR // EUROPEAN UNION EUROS // € 1				755-5401-01-Y	
ON	▲	PORTUGAL	0.50		0.50	1/0.50		755-5401-01-Y
OFF	▼							
Pos.	1 2 3 4 5 6 7 8	Default Highlighted	EUR // EUROPEAN UNION EUROS // € 1				755-5401-08-Y	
ON	▲	SPAIN Euro 8	0.50	1.00	2.00	1/1.00	3/2.00	
OFF	▼							

HIGHLIGHTED = Factory Default **HIGHLIGHTED** = Not Shown on Coin Card

For the associated Coinage Card required if the Factory Default Setting was changed, view on-line at:

<http://www.sternpinball.com/coinagecards.shtml>

You can download and print the replacement card. Adobe® Reader 5.0 or higher required (links on site). Use Yellow Card Stock: ASTROBRIGHTS® SOLAR YELLOW #65 FROM WAUSAU PAPER PRODUCTS (Stock #22731)

- #19 **MATCH PERCENTAGE:** Set between 0% – 10% or OFF. Factory Default = 9%. At 0% the Match Animation Feature occurs at the end of the game but never awards the Match Award (Standard Adjustment 20). Set to OFF, no Match Animation Feature is shown.
- #20 **MATCH AWARD:** Set to CREDIT, TICKET* or TOKEN*. Factory Default = CREDIT. This adjustment is not shown if OFF is installed in Match Percentage (Standard Adjustment 19).
*Note: If TICKET or TOKEN is selected, the game will require an optional Ticket or Token Dispenser and then Q24 Option (Standard Adj. 55) must be changed accordingly.
- #21 **BALLS PER GAME:** Set between 1 – 10. Factory Default = 3. Set the number of balls per game.

Standard Adjustments 22-36 continued on the next page.



Standard Adjustments continued.

- #22 **TILT WARNINGS:** Set between **0 – 3**. Factory Default = **2**. Set the number of Plumb Bob Tilt Switch closures before the ball in play is tilted. *Each closure generates an audible alert and/or display alert.*
- #23 **CREDIT LIMIT:** Set between **4 – 50**. Factory Default = **30**. Set the maximum credits allowed.
- #24 **ALLOW HIGH SCORES:** Set to **YES** or **NO**. Factory Default = **YES**. When set to **YES**, if a player exceeds the Default Grand Champion or 1-4 High Scores, the player may receive a **High Score Award** (Standard Adjustment 25) and enter their **3 Initials** or **10-Letter Name** (Standard Adjustment 36). Set to **NO** to disable this feature. *The following Standard Adjustments 25-37 are not shown if **NO** is installed.*
- #25 **HIGH SCORE AWARD:** Set to **CREDIT**, **TICKET*** or **TOKEN***. Factory Default = **CREDIT**. Set the type of award to be given to the player when the appropriate **Grand Champion Score** or **High Score #1 – #4** threshold or level is achieved. If awarding a **CREDIT**, **TICKET** or **TOKEN** is prohibited in your area, install **NO** in **Allow High Scores** (Standard Adjustment 24). *This adjustment is not shown if **NO** is installed in **Allow High Scores** (Standard Adjustment 24).*
- *Note: If **TICKET** or **TOKEN** is selected, the game will require an optional Ticket or Token Dispenser and then **Q24 Option** (Standard Adj. 55) must be changed accordingly.*
- #26 **GRAND CHAMPION AWARDS:** Set between **0 – 5**. Factory Default = **1**. Set the number of **High Score Award(s)** (Std. Adj. 25), awarded for exceeding the Grand Champion Score (Standard Adjustment 31). *This adjustment is not shown if **NO** is installed in **Allow High Scores** (Standard Adjustment 24).*
- #27 **HIGH SCORE #1 AWARDS:** Set between **0 – 3**. Factory Default = **1**. Set the number of **High Score Award(s)** (Std. Adj. 25), awarded for exceeding the High Score #1 (Standard Adjustment 32). *This adjustment is not shown if **NO** is installed in **Allow High Scores** (Standard Adjustment 24).*
- #28 **HIGH SCORE #2 AWARDS:** Set between **0 – 2**. Factory Default = **0**. Set the number of **High Score Award(s)** (Std. Adj. 25), awarded for exceeding the High Score #2 (Standard Adjustment 33). *This adjustment is not shown if **NO** is installed in **Allow High Scores** (Standard Adjustment 24).*
- #29 **HIGH SCORE #3 AWARDS:** Set between **0 – 1**. Factory Default = **0**. Set the number of **High Score Award(s)** (Std. Adj. 25), awarded for exceeding the High Score #3 (Standard Adjustment 34). *This adjustment is not shown if **NO** is installed in **Allow High Scores** (Standard Adjustment 24).*
- #30 **HIGH SCORE #4 AWARDS:** Set between **0 – 1**. Factory Default = **0**. Set the number of **High Score Award(s)** (Std. Adj. 25), awarded for exceeding the High Score #4 (Standard Adjustment 35). *This adjustment is not shown if **NO** is installed in **Allow High Scores** (Standard Adjustment 24).*
- #31 **GRAND CHAMPION SCORE:** Set between **1,000,000 – 1,000,000,000** (increments of 1,000,000). Factory Default = **75,000,000**. Set the desired **Grand Champion Score** level a player needs to exceed to earn the **High Score Award** (Standard Adjustment 25). A score higher than the default, cannot be reset by Standard Adjustment 37, **HSTD Reset Count**. *The Grand Champion Score will revert to the Factory Default Score **ONLY** if a **Reset Grand Champion** is performed in the **RESET MENU** (via the **UTILITIES MENU**, see Section 3, Chapter 5) or if the game is without power for more than 12 hours after the CPU/Sound PCB Coin Cell Battery is expired or removed. This adjustment is not shown if **NO** is installed in **Allow High Scores** (Standard Adjustment 24).*
- #32 **HIGH SCORE #1:** Set between **1,000,000 – 1,000,000,000**. Factory Default = **55,000,000**. Set the desired **High Score #1** level a player needs to exceed to earn the **High Score Award** (Standard Adjustment 25). A score higher than the default, will be reset by Standard Adjustment 37, **HSTD Reset Count**. *The High Score will revert to the Factory Default Score **ONLY** if a **Reset High Scores** is performed in the **RESET MENU** (via the **UTILITIES MENU**, see Section 3, Chapter 5) or if the game is without power for more than 12 hours after the CPU/Sound PCB Coin Cell Battery is expired or removed. This adjustment is not shown if **NO** is installed in **Allow High Scores** (Standard Adjustment 24).*
- #33 **HIGH SCORE #2:** Set between **1,000,000 – 1,000,000,000**. Factory Default = **40,000,000**. Set the desired **High Score #2** level a player needs to exceed ... (continued in Standard Adjustment 32 definition above).
- #34 **HIGH SCORE #3:** Set between **1,000,000 – 1,000,000,000**. Factory Default = **30,000,000**. Set the desired **High Score #3** level a player needs to exceed ... (continued in Standard Adjustment 32 definition above).
- #35 **HIGH SCORE #4:** Set between **1,000,000 – 1,000,000,000**. Factory Default = **25,000,000**. Set the desired **High Score #4** level a player needs to exceed ... (continued in Standard Adjustment 32 definition above).
- #36 **HSTD (HIGH SCORE TO DATE) INITIALS:** Set to **3 INITIALS** or **10 LETTER NAME**. Factory Default = **3 INITIALS**. When set to **3 INITIALS**, the player is allowed only 3 initials to input. When set to **10 LETTER NAME**, the player is allowed to enter 10 initials to input. *This adjustment is not shown if **NO** is installed in **Allow High Scores** (Standard Adjustment 24).*

Standard Adjustments 37-49 continued on the next page.



Standard Adjustments continued.

- #37 **HSTD (HIGH SCORE TO DATE) RESET COUNT:** Set between **100 – 9900** or **OFF** (increments of 100). Factory Default = **2000**. Set the number of games between "automatic resets" of High Scores back to the Factory Defaults for **ONLY** Standard Adj. **32 – 35, High Score #1 – #4**. The High Score will revert to the Factory Default Scores when the number of games stated is reached. **Reset High Scores** can be performed in the **RESET MENU** (via the **UTILITIES MENU**, see Sec. 3, Chp. 5) anytime or if the game is without power for more than 12 hours after the CPU/Sound PCB Coin Cell Battery is expired or removed. This adjustment is not shown if **NO** is installed in **Allow High Scores** (Standard Adj. 24).
- #38 **FREE PLAY:** Set to **YES** or **NO**. Factory Default = **NO**. When set to **YES**, no coins are required for Game Play.
- #39 **LANGUAGE:** Set to **ENGLISH, GERMAN, FRENCH, SPANISH** or **ITALIAN**. Factory Default = **ENGLISH**. Set the language for the game. Language of game is also shown in the Dot Display (along with the Game Title and code version) at the start-up routine which follows a game reset or power-up.
- #40 **PLAYER LANGUAGE SELECT:** Set to **YES** or **NO**. Factory Default = **YES**. When set to **YES**, after the player presses the **Start Button** (to start a game with adequate credit), the player has the option to choose a language by pressing either **Flipper Button** before game start (options of languages installed are shown on the Dot Display). **Note:** If set to **NO** or if only one language is installed and the setting is set to **YES**, the game will start immediately after the **Start Button** press. Language(s) available are dependent on game destination from the factory. Other languages may be available on-line for download and installed on your game. With the proper dip switch installed, the language option(s) can be changed. For more information or help, call Technical Support at 800-542-5377 (708-345-7700).
- #41 **CUSTOM MESSAGE:** Set to **ON, CHANGE** or **OFF**. Factory Default = **ON**. Shortcut: **Enter Custom Message** and instructions, review Sec. 3, Chp. 5, **GO TO UTILITIES MENU, Enter Custom Message**.
- #42 **FLASH LAMP POWER:** Set to **NORMAL, OFF** or **DIM**. Factory Default = **NORMAL**. When set to **DIM**, the Flash Lamps impulse power is reduced by **25%** and when set to **OFF** the Flash Lamps will not flash. For Flash Lamps used in this game, **Go To Flash Lamps Menu** via the **DIAGNOSTICS MENU** (see Section 3, Chapter 2, **GO TO DIAGNOSTICS MENU, Page 15**).
- #43 **COIL PULSE POWER:** Set to **NORMAL, HARD** or **SOFT**. Factory Default = **NORMAL**. When set to **HARD**, the coil pulse power is **increased** by **12.5%** of the normal pulse rate. When set to **SOFT** the coil pulse power is **decreased** by **12.5%** of the normal pulse rate. This adjustment is provided to compensate for **Low Line** or **High Line** voltage conditions where the solenoids (coils) appear to **kicking too weak** or **too hard**. Adjust as required.
- #44 **KNOCKER VOLUME:** Set to **NORMAL, OFF** or **LOW**. Factory Default = **NORMAL**. When set to **LOW**, the volume is decreased 50%. When set to **OFF**, no sound is heard when the "knocker" is sounded. Test the knocker sound in the **Fire Knocker Test** via the **DIAGNOSTICS MENU** (see Section 3, Chapter 2, **GO TO DIAGNOSTICS MENU, Page 19**).
- #45 **GAME RESTART:** Set to **YES** or **NO**. Factory Default = **YES**. When set to **YES**, a new game may be started during any ball after the first ball is completed (if credits allow). Pressing the Start Button during the first ball will add additional players (up to 4, if credits allow). When set to **NO**, the game disables the Start Button after the first ball until the final ball is in play.
- #46 **BILL VALIDATOR:** Set to **YES** or **NO**. Factory Default = **NO**. When set to **YES**, in **Game Attract Mode** an "Insert Bill Animation" is shown in the display (or just the absense of the Coin Animation). When set to **NO**, an "Insert Coin Animation" is shown. **Not yet implemented.**
- #47 **MUSIC VOLUME:** Set between **1 – 15**. Factory Default = **1**. After volume is set via Service Buttons this adjustment can be utilized to adjust the background music (1 all the way on, 15 all the way off) while keeping the Special Sound Effects at the same level.
- #48 **BALL SAVE TIME:** Set between **0:01 – 0:15, AUTO** or **NO BALL SAVES**. Factory Default = **0:05**. When set to **NO BALL SAVES** this feature is unavailable. Set between **0:01** through **0:15** (single increments) for the ball to be sent back into play if the time set is not met (per ball). Set to **AUTO** to automatically adjust the Ball Save Timer based on the average ball time.
- #49 **TIMED PLUNGER:** Set to **OFF** or **0:01 – 1:00**. Factory Default = **OFF**. The plunger will "Autoplunge" the ball (at the time set) when the ball is at the beginning of play, waiting for the player.

Sec. 3: Go To Adjust.

Standard Adjustments 50-63 continued on the next page.





Standard Adjustments continued.

- #50 **FLIPPER BALL LAUNCH:** Set to **OFF**, **LEFT FLIPPER**, **RIGHT FLIPPER**, **EITHER FLIPPER** or **BOTH FLIPPERS**. Default is **OFF**. This feature allows the player to operate the Auto Ball Launch with the Flipper Button(s) depending on which setting is chosen.
- #51 **COINDOOR BALL SAVER:** Set to **YES** or **NO**. Factory Default = **NO**. When set to **NO**, this feature is not available. When set to **YES**, this feature allows the Coin Door to be opened during game play; the ball will drain but the game will be placed "on hold". When the Coin Door is closed, the pinball will return to the Shooter Lane, and the game will resume. *Useful at locations where technicians change the cash box regularly at exact times of the day where players can be on the game.*
- #52 **COMPETITION MODE:** Set to **YES** or **NO**. Factory Default = **NO**. When set to **NO**, this feature is not available. Set to **YES**, this feature will equalize random game features and global score values during multi-player games by predetermined competition rules set by programming. If an **Install Competition** was made via the **INSTALLS MENU** (which automatically changes this setting to **YES**), and this setting was changed back to **NO**, the **Competition Mode** will be turned **OFF** (cancelled).
- #53 **CONSOLATION BALL:** Set to **YES** or **NO**. Factory Default = **NO**. When set to **YES**, the **EXTRA BALL** (lamp insert, location varies) will be lit on the last ball in play, if certain programming criteria is met.
- #54 **FAST BOOT:** Set to **YES** or **NO**. Factory Default = **YES**. When set to **NO** or if you hold both Flipper Buttons during Power-Up, this feature is not available and will display all normal Power-Up screens. When set to **YES**, the game will not display the normal informative Power-Up screens, specifically the CPU Version screen and the Location/Game ID screen. Regardless of the setting, normal Power-Up safety checks are still performed. **Not yet implemented.**
- #55 **Q24 OPTION:** Set to **COIN METER**, **TOKEN DISPENSER** or **KNOCKER**. Factory Default = **COIN METER**. This Coil (Solenoid) Location is left "open" at the Factory to allow for these optional Mechanisms to be added to the game. If selecting **TOKEN DISPENSER**, Standard Adjustments 3, 14, 20 & 25 should be changed to **TOKEN**. Call Tech. Support at 1-800-542-5377 if more information is required on this option.
- #56 **TICKET DISPENSER:** Set to **YES** or **NO**. Factory Default = **NO**. This adjustment is required only for games which have an optional Deltronics (DL-1275-2 PCB Style, SPI Part Nr. 515-7275-00) Ticket Dispenser installed. Unique CPU Sound Bd. Dip Switch Setting required, changes the Default to **YES**.
- #57 **PLAYER COMPETITION:** Set to **YES** or **NO**. Factory Default = **YES**. **Competition Mode** unrandomizes feature events, and standardizes game play and rule sets (varies from game to game) for fair competitions. With at least one credit posted, or with the game set for 'FREE PLAY', during the game-over Attract Mode, press the **Left Flipper Button** and hold it in for approximately one second. The following message will appear on the display for approximately 10 seconds: '**COMPETITION MODE READY ... PRESS START NOW**'. If a game is started (either by pressing the 'START' button for a regular game, or by pressing the 'TOURNAMENT START' button for a tournament game) while this message appears on the display, then competition mode will be enabled for all players during the game. General rules are covered in the Instruction Card. Other Hints and/or Rules can be made known on this game either visually (the Dot Display or Flashing Light Inserts) or can be audible.
- #58 **TEAM SCORES:** Set to **YES** or **NO**. Factory Default = **NO**. Set to **YES**, then Team Play will be made available. **Team Play only works in a 4-Player Game**. The totals for Players 1 / 3 (Team 1) & Players 2 / 4 (Team 2) are then displayed individually **as well as** the combined score for **BOTH TEAMS** to enable **Team Play (Doubles)**. See Section 2, Chapter 1, **Game Operation & Features**, for non-adjustable Features.
- #59 **LOCATION ID:** Set between **0** to **9999**. Factory Default = **0**. This adjustment allows the operator to assign a location identification number to the audit print-out sheet. (Will not be affected by a Factory Reset.)
- #60 **GAME ID:** Set between **0** to **9999**. Factory Default = **0**. This adjustment allows the operator to assign a game identification number to the audit print-out sheet. (Will not be affected by a Factory Reset.)
- #61 **TIME FORMAT:** Set to **12-HOUR** or **24-HOUR**. Factory Default = **12-HOUR**. This adjustments determines how the time is displayed. Time used for Tournament and Data Dumps where a time stamp is required.
- #62 **COIN INPUT DELAY:** Set between **30** to **60** or **OFF**. Factory Default = **30**. This adjustment creates a short time delay between the moment the coin is inserted into the **Coin Slot** to the moment the CPU/Sound PCB registers the coin (30 = approximately 1/2 second).
- #63 **LOST BALL RECOVERY:** Set to **YES** or **NO**. Factory Default = **NO**. Set to **YES**, at the start of the 5th consecutive ball search (with no scoring between searches), the game will consider any balls in play to be permanently lost and will attempt to recover from this situation by serving a new ball into play from the ball trough. Set to **NO** (to suppress this adjustment behavior) for the game to perform the "ball search" indefinitely until the lost balls are found or replaced.

STANDARD ADJUSTMENTS [#1 – #63] ▼

Nr.	STANDARD ADJUSTMENT NAME	USA DEFAULT	YOUR SETTING	Nr.	STANDARD ADJUSTMENT NAME	USA DEFAULT	YOUR SETTING
1	REPLAY TYPE	AUTO		32	HIGH SCORE #1	55,000,000	
2	‡ REPLAY PERCENTAGE	10%		33	HIGH SCORE #2	40,000,000	
3	‡ REPLAY AWARD	CREDIT		34	HIGH SCORE #3	30,000,000	
4	‡ REPLAY LEVELS	1		35	HIGH SCORE #4	25,000,000	
5	‡ AUTO REPLAY START	20,000,000		36	HSTD INITIALS	3 INITIALS	
6	‡ DYNAMIC REPLAY START	60,000,000		37	HSTD RESET COUNT	2000	
7	‡ REPLAY LEVEL #1	15,000,000		38	FREE PLAY	NO	
8	‡ REPLAY LEVEL #2	30,000,000		39	LANGUAGE	ENGLISH	
9	‡ REPLAY LEVEL #3	45,000,000		40	PLAYER LANGUAGE SELECT	YES	
10	‡ REPLAY LEVEL #4	60,000,000		41	CUSTOM MESSAGE	ON	
11	‡ REPLAY BOOST	YES		42	FLASH LAMP POWER	NORMAL	
12	SPECIAL LIMIT	1		43	COIL PULSE POWER	NORMAL	
13	‡ SPECIAL PERCENTAGE	10%		44	KNOCKER VOLUME	NORMAL	
14	SPECIAL AWARD	CREDIT		45	GAME RESTART	YES	
15	FREE GAME LIMIT	5		46	BILL VALIDATOR	NO	
16	EXTRA BALL LIMIT	5		47	MUSIC VOLUME	1	
17	‡ EXTRA BALL PERCENTAGE	25%		48	BALL SAVE TIME	0:05	
18	GAME PRICING	USA 10		49	TIMED PLUNGER	OFF	
19	MATCH PERCENTAGE	9%		50	FLIPPER BALL LAUNCH	OFF	
20	MATCH AWARD	CREDIT		51	COINDOOR BALL SAVER	NO	
21	BALLS PER GAME	3		52	COMPETITION MODE	NO	
22	TILT WARNINGS	2		53	CONSOLATION BALL	YES	
23	CREDIT LIMIT	30		54	FAST BOOT	YES	
24	ALLOW HIGH SCORES	YES		55	Q24 OPTION	COIN METER	
25	HIGH SCORE AWARD	CREDIT		56	TICKET DISPENSER	NO	
26	GRAND CHAMPION AWARDS	1		57	PLAYER COMPETITION	YES	
27	HIGH SCORE #1 AWARDS	1		58	TEAM SCORES	NO	
28	HIGH SCORE #2 AWARDS	0		59	LOCATION ID	0	
29	HIGH SCORE #3 AWARDS	0		60	GAME ID	0	
30	HIGH SCORE #4 AWARDS	0		61	TIME FORMAT	12-HOUR	
31	GRAND CHAMPION SCORE	75,000,000		62	COIN INPUT DELAY	30	
				63	LOST BALL RECOVERY	YES	

Sec. 3: Go To Adjust.

Factory Defaults Settings are subject to change during production (especially Standard Adjustments 2, 4, 5, 13, 16-17, 19, 31-35 & 47).
 ‡ Not all Standard Adjustments are shown. Depending on the setting (whether Factory Default or if changed by the operator), associated adjustments do not appear, if not required. **Note:** If Game Dip Switch other than USA is installed, different Defaults will appear.





Feature Adjustments [#1 – #26]

To initiate, from the **ADJUSTMENTS MENU**, select the " 'S' " *Icon*. The Dot Matrix Display will indicate the *adjustment number (in this group), adjust. name, adjust. setting and comment line*. The current adjustment will remain on the display until the next adjustment is viewed or when this sub-menu is exited.

- #1 **ADULT CONTENT ENABLED** : Set to **FAMILY** or **MODERATE**.
Factory Default = **FAMILY**. Controls whether the game will make use of more mature content.
Also reference Instruction Sheet 756-5036-93 .
MODERATE : partially-censored, if applicable.
FAMILY : censored! no offensive sounds and no swearing.
- #2 **POPS AT BALL START** : Set between **0 – 6**. Factory Default = **1**. *Determines how this feature is started and played.*
- #3 **PINBALL SPELLOUT DIFFICULTY** : Set to **EXTRA EASY, EASY, MEDIUM, HARD** or **EXTRA HARD**.
Factory Default = **MEDIUM**. *Determines how this feature is started and played.*
- #4 **MINI CHARM LETTERS SPOTTED** : Set between **0 – 4**. Factory Default = **0**.
Determines how many letters in C-H-A-R-M are lit at Donkey Pinball Game Start.
- #5 **MINI MAN LETTERS SPOTTED** : Set between **0 – 2**. Factory Default = **0**.
Determines how many letters in M-A-N are lit at Donkey Pinball Game Start.
- #6 **MINI SHREK LETTERS SPOTTED** : Set between **0 – 4**. Factory Default = **0**.
Determines how many letters in S-H-R-E-K are lit at Donkey Pinball Game Start.
- #7 **MINI PUSS LETTERS SPOTTED** : Set between **0 – 3**. Factory Default = **0**.
Determines how many letters in P-U-S-S are lit at Donkey Pinball Game Start.
- #8 **MINI FIONA LETTERS SPOTTED** : Set between **0 – 4**. Factory Default = **0**.
Determines how many letters in F-I-O-N-A are lit at Donkey Pinball Game Start.
- #9 **MINI PLAYFIELD MIN. PLAY TIME** : Set between **10 – 20**. Factory Default = **15**.
Determines the starting minimum count-down timer (in seconds) "Shoot Again" remains lit (allowing the ball to be returned to play after a ball drain between the mini flippers).
- #10 **MINI PLAYFIELD MAX PLAY TIME** : Set between **25 – 60**. Factory Default = **30**.
Determines the maximum count-down timer (in seconds) "Shoot Again" a player can have to remain lit (allowing the ball to be returned to play after a ball drain between the mini flippers).
- #11 **MINI PF TIME DONKEY INCREMENT** : Set between **1 – 3**. Factory Default = **1**.
Determines the increment in seconds the maximum play time gets increased when this feature is collected.
- #12 **LETTERS PER MINI PF SHOT** : Set between **1 – 5**. Factory Default = **2**.
Determines how many letters in each family name is lit when the switch is closed for the particular shot.
Left Orbit : **FIONA** Left Stand-Up Target : **MAN** Center Stand-Up Target : **SHREK**
Ramp : **PUSS** Right Orbit : **CHARM**
- #13 **MINI PLAYFIELD ENDING** : Set to **SUDDEN DEATH, SUDDEN DEATH + TIMER** or **INSTANT**. Factory Default = **SUDDEN DEATH**.
Determines how Donkey Pinball play ends when the display timer runs out (Shoot Again now unlit).
SUDDEN DEATH = Flippers die when ball drains (*play continues as long as the ball does not drain*).
SUDDEN DEATH + TIMER = Flippers die when audible timer reaches 0.
(audible timer starts when the display timer ends)
INSTANT = Flippers die instantly when the display timer reaches 0.
- #14 **BURP MULTIBALL DIFFICULTY** : Set to **EXTRA EASY, EASY, MEDIUM, HARD** or **EXTRA HARD**.
Factory Default = **MEDIUM**. *Determines how this feature is started and played.*
- #15 **PUSS IN BOOTS DIFFICULTY** : Set to **EXTRA EASY, EASY, MEDIUM, HARD** or **EXTRA HARD**.
Factory Default = **MEDIUM**. *Determines how this feature is started and played.*
- #16 **SHOW MINI FLIPPERS** : Set to **YES** or **NO**. Factory Default = **YES**. *Determines if the mini flippers are energized 3 times to get the player's attention to look up the first time Donkey Pinball is started.*
- #17 **POPS CARRYOVER** : Set to **YES** or **NO**. Factory Default = **NO**. *Determines if this feature stays lit on the next ball if feature wasn't completed before the play in play ended.*
- #18 **SWAMP DIFFICULTY** : Set to **EXTRA EASY, EASY, MEDIUM, HARD** or **EXTRA HARD**.
Factory Default = **HARD**. *Determines how this feature is started and played.*

Feature Adjustments 19-26 continued on the next page.



Feature Adjustments continued.

- #19 **LEFT RAMP DIFFICULTY** : Set to **EXTRA EASY, EASY, MEDIUM, HARD** or **EXTRA HARD**.
Factory Default = **MEDIUM**. *Determines how this feature is started and played.*
- #20 **BALL SAVER POST TIME** : Set between **5 – 20**. Factory Default = **9**. *Determines how many seconds the Ball Saver Post remains in the up position when activated (hitting the 1-Bank Drop Target when the Death Lamp is lit).*
- #21 **DRAGON MULTIBALLS** : Set between **1 – 10** or **OFF**. Factory Default = **3**.
Set the maximum number for this feature. Determines how this feature is started and played.
- #22 **DISABLE BALL SAVER POST** : Set to **YES** or **NO**. Factory Default = **NO**.
Set to **YES** if the Ball Saver Post coil and/or switches are awaiting repair or replacement.
- #23 **DISABLE 4-BANK** : Set to **YES** or **NO**. Factory Default = **NO**.
Set to **YES** if the 4-Bank Drop Target coil and/or PCB switches are awaiting repair or replacement.
- #24 **DISABLE 1-BANK** : Set to **YES** or **NO**. Factory Default = **NO**.
Set to **YES** if the 1-Bank Drop Target coil and/or PCB switch are awaiting repair or replacement.
- #25 **DISABLE MINI PLAYFIELD** : Set to **YES** or **NO**. Factory Default = **NO**. Disable the playfield manually.
Set to **YES** if the left flipper, right flipper, shooter coils and/or PCB switches (*ramp OPTOs or piezo stand-ups*) are awaiting repair or replacement. *In doing so, when all letters in **P-I-N-B-A-L-L** are spelled and the TV hole shot is made, the player will be awarded 1,000,000 points for the 1st occurrence (subject to change) and an incremental increase of 250,000 (subject to change) with each subsequent "play" of Donkey Pinball.*
- #26 **SMART MINIPF ERROR CHECK** : Set to **YES** or **NO**. Factory Default = **YES**. Disables the playfield automatically (see Feature Adjustment 25). Set to **NO** if you >>**do not want**<< the game to **AUTOMATICALLY** check if the left flipper, right flipper, shooter coils and/or PCB switches (*ramp and orbit OPTOs or piezo stand-ups*) are malfunctioning or not.

Note: *The game may determine a long duration of inactivity as a malfunction. If the game had automatically turned off the mini-playfield, and after all switches and coils were determined to be functioning normally in Switch and Coil Tests, turn this adjustment to **NO**.*

FEATURE ADJUSTMENTS [#1 – #26] ▼

Nr.	FEATURE ADJUSTMENT NAME	USA DEFAULT	YOUR SETTING	Nr.	FEATURE ADJUSTMENT NAME	USA DEFAULT	YOUR SETTING
1	ADULT CONTENT ENABLED	MODERATE		14	BURP MULTIBALL DIFFICULTY	MEDIUM	
2	POPS AT BALL START	1		15	PUSS IN BOOTS DIFFICULTY	MEDIUM	
3	PINBALL SPELLOUT DIFFICULTY	MEDIUM		16	SHOW MINI FLIPPERS	YES	
4	MINI CHARM LETTERS SPOTTED	0		17	POPS CARRYOVER	NO	
5	MINI MAN LETTERS SPOTTED	0		18	SWAMP DIFFICULTY	HARD	
6	MINI SHREK LETTERS SPOTTED	0		19	LEFT RAMP DIFFICULTY	MEDIUM	
7	MINI PUSS LETTERS SPOTTED	0		20	BALL SAVER POST TIME	9	
8	MINI FIONA LETTERS SPOTTED	0		21	DRAGON MULTIBALLS	3	
9	MINI PLAYFIELD MIN. PLAY TIME	15		22	DISABLE BALL SAVER POST	NO	
10	MINI PLAYFIELD MAX PLAY TIME	30		23	DISABLE 4-BANK	NO	
11	MINI PF TIME DONKEY INCREMENT	1		24	DISABLE 1-BANK	NO	
12	LETTERS PER MINI PF SHOT	2		25	DISABLE MINI PLAYFIELD	NO	
13	MINI PLAYFIELD ENDING	SDN DEATH		26	SMART MINIPF ERROR CHECK	YES	

Sec. 3: Go To Adjust.





To initiate, from the **MAIN MENU**, select the "UTIL" *Icon*. The **UTILITIES MENU** provides ways to quickly and easily customize your game with **Installs** (*pre-sets for game Standard & Feature Adjustments*), set-up a **Custom Message** (*short-cut to Standard Adjustment 41, Custom Message*), set-up **Custom Pricing** (*short-cut to Standard Adjustment 18, to the Custom Pricing Sub-Menu*), set-up the **Date and Time** (*required if the date and time is needed to be accurate for data dumps and for tournaments*), reset certain particular game data or perform a complete **Factory Reset** and to download game data, update or backup game code in the **USB MENU**.

All **UTILITIES, INSTALLS, RESETS MENU** and **USB MENU** *Icons* and there usages are explained throughout this chapter in the same order as seen in the Dot Matrix Display. **NOTE:** Depending on Game Type, Version, selections made, Dip Switch settings, location and/or areas, some *Icons* may appear non-functional or may not appear at all. **Installs (Adjustments), Icons and/or functions, order and operation are subject to change. If in doubt use the Factory Default Settings** (*review Install Factory on the next page*).

In displays where changes can be made or to perform a function, use the **GREEN Button** to go [**BACK**], exit or escape, the **RED Buttons** to [**</-**] MOVE BACK / LEFT / [**+ / >**] MOVE FORWARD / RIGHT to view the next audit in the group, and the **BLACK Button** to [**SELECT**] the sub-menus.



Go To Installs Menu

To initiate, from the **UTILITIES MENU**, select the "INST" *Icon*. The **INSTALLS MENU** provides **13 Installs** to vary **Game Play Difficulty** (*set with Feature Adjustments*) or **Game Play Type** and **Install Factory** (*restores all adjustments to Factory Defaults*).

For **detailed customization** or to check current **Adjustments Defaults** (*either changed by YOU in the Adjustments Menu or by this INSTALLS MENU or for Factory Default Settings*), see **Section 3, Chapter 4, GO TO ADJUSTMENTS MENU**. After completing one or more of the **Installs** in this chapter, go back to the **ADJUSTMENTS MENU** to see which **Standard and/or Feature Adjustments** have changed (*Feature Adjustments and/or settings are subject to change during production, and may differ than what is described in the tables at the end of this chapter*). The Dot Display will indicate if a setting is a **Factory Default** or not. If the settings are not to your liking, perform **one** of the following:

- 1.: **Manually** change the **Standard & Feature Adjustments** Settings (*perform this task in the ADJUSTMENTS MENU, see Section 3, Chapter 4, GO TO ADJUSTMENTS MENU*).
- 2.: **Install Factory** (*see the last install*) on how to reset all of the **Standard & Feature Adjustments** back to the **Factory Default Settings**.

Multiple **Installs can be set** to vary game play; however, for **Installs** that have *one or more* Adjustments in common, the **last** "Install" selected & **activated**, will **supersede** any previously changed Adjustment(s) from any prior **Installs**. Any adjustments which you changed and are not affected by the Install will remain as set.

For example, if you want a **5-BALL Game** set to **EXTRA EASY**: Select and **activate** the "5BAL" *Icon first* (which will typically change any **Feature** Difficulty Adjustments to **HARD**), **then** select & **activate** the "X.EZ" *Icon* to **change back** the Difficulty Adjustments to **EXTRA EASY**. However, if the "X.EZ" *Icon* was selected & **activated** first, **then** the "5BAL" *Icon* was selected & **activated**, the game will be set to a **5-BALL Game** set to **HARD**.

Remember, use the **GREEN Button** to go [**BACK**], exit or escape and the **BLACK Button** to [**SELECT**] to **INSTALL** your new setting(s).

INSTALLS MENU continued on the next page.

INSTALLS MENU Continued.



Install Extra Easy, Easy, Medium (**Normal or Factory Settings**), Hard or Extra Hard

To initiate, from the **INSTALLS MENU**, select one of the "X.EZ," "EASY," "FACT," "HARD," or "X.HD" *Icons*. The Dot Matrix Display

will indicate the **INSTALL EXTRA EASY, EASY, MEDIUM, HARD or EXTRA HARD** depending on choice. Follow the on-screen prompts to perform the **Install**. Set the **Game Play Difficulty** level.



Install 3-Ball

To initiate, from the **INSTALLS MENU**, select the "3BAL" *Icon*. The Dot Matrix Display will indicate the **INSTALL 3-BALL**. Follow the on-screen prompts to perform the **Install**.

Set the **Game Play Type** to 3 Balls per game (*Factory Default is 3 Balls per game, not including extra's...*).



Install 5-Ball

To initiate, from the **INSTALLS MENU**, select the "5BAL" *Icon*. The Dot Matrix Display will indicate the **INSTALL 5-BALL**. Follow the on-screen prompts to perform the **Install**.

Set the **Game Play Type** to 5 Balls per game (*not including extra balls earned by the player, if any*).



Install Competition

To initiate, from the **INSTALLS MENU**, select the "COMP" *Icon*. The Dot Matrix Display will indicate the **INSTALL COMPETITION**. Follow the on-screen prompts to perform the **Install**.

Set the **Game Play Type** to "Tournament" Rules. *Programming varies and is subject to change.*



Install Director's Cut

To initiate, from the **INSTALLS MENU**, select the "DCUT" *Icon*. The Dot Matrix Display will indicate the **INSTALL DIRECTOR'S CUT**. Follow the on-screen prompts to perform the **Install**.

Set the **Game Play Type** to programmer's choice. *Programming varies and is subject to change.*



Install Home Play

To initiate, from the **INSTALLS MENU**, select the "HOME" *Icon*. The Dot Matrix Display will indicate the **INSTALL HOME PLAY**. Follow the on-screen prompts to perform the **Install**.

Set the **Game Play Type** to "Home" Rules. *Programming varies and is subject to change.*



Install Novelty

To initiate, from the **INSTALLS MENU**, select the "NOV" *Icon*. The Dot Matrix Display will indicate the **INSTALL NOVELTY**. Follow the on-screen prompts to perform the **Install**.

***** This setting is recommended where local laws restrict certain game features. *****

Set the **Game Play Type** to "Restricted" Rules. *Programming varies and is subject to change.*



Install Add-A-Ball

To initiate, from the **INSTALLS MENU**, select the "A.A.B." *Icon*. The Dot Matrix Display will indicate the **INSTALL ADD-A-BALL**. Follow the on-screen prompts to perform the **Install**.

***** This setting is recommended where local laws restrict certain game features. *****

Set the **Game Play Type** to "Restricted" Rules. *Programming varies and is subject to change.*

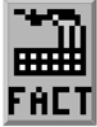

Install Factory

To initiate, from the **INSTALLS MENU**, select the "FACT" *Icon*. The Dot Matrix Display will indicate the **INSTALL FACTORY**. Follow the on-screen prompts to perform the **Install**. **CAUTION!** All **Standard and Feature Adjustments** which were changed in the **INSTALLS MENU** or **ADJUSTMENTS MENU** are returned to the **Factory Defaults** (as indicated in the Dot Display in the **ADJUSTMENTS MENU**). *Note: To perform a complete **Factory Reset**, GO TO THE RESETS MENU. Escape back to the UTILITIES MENU, select the "RESET" Icon, then select the "FACT" Icon in the RESETS MENU (review the end of this chapter, Page 40, Reset Factory Settings).*

INSTALLS MENU continued on the next page.

Overview of Factory Defaults which change with a Particular Install

STANDARD ADJUSTMENTS (ADJUSTMENTS NOT AFFECTED ARE NOT SHOWN) ▼

Nr.	STANDARD ADJUSTMENT NAME	INSTALL FACTORY	INSTALL MEDIUM *	INSTALL 3-BALL	INSTALL 5-BALL	INSTALL COMPETITION	INSTALL DIRECTOR'S CUT *	INSTALL HOME PLAY *	INSTALL NOVELTY	INSTALL ADD-A-BALL
1	REPLAY TYPE	AUTO		AUTO	AUTO	AUTO			NONE	AUTO
2	REPLAY PERCENTAGE	10%		10%	10%	10%				10%
3	REPLAY AWARD	CREDIT		CREDIT	CREDIT	CREDIT				EX. BALL
4	REPLAY LEVELS	1		1	1	1				1
5	AUTO REPLAY START	20,000,000		20,000,000	20,000,000	20,000,000				20,000,000
6	DYNAMIC REPLAY START	60,000,000								
7	REPLAY LEVEL #1	15,000,000								
8	REPLAY LEVEL #2	30,000,000								
9	REPLAY LEVEL #3	45,000,000								
10	REPLAY LEVEL #4	60,000,000								
11	REPLAY BOOST	YES		YES	YES	YES				YES
12	SPECIAL LIMIT	1		1	1	1			1	1
13	SPECIAL PERCENTAGE	10%		10%	10%	10%			10%	10%
14	SPECIAL AWARD	CREDIT		CREDIT	CREDIT	CREDIT			POINTS	EX. BALL
15	FREE GAME LIMIT	5		5	5	5			NO FREE...	NO FREE...
16	EXTRA BALL LIMIT	5		5	5	5			NO EXTRA	9
17	EX. BALL PERCENTAGE	25%		25%	25%	25%			25%	25%
18	GAME PRICING	USA 5		USA 5	USA 5	USA 5			USA 5	USA 5
19	MATCH PERCENTAGE	9%		9%	9%	9%			OFF	OFF
20	MATCH AWARD	CREDIT		CREDIT	CREDIT	CREDIT			CREDIT	CREDIT
21	BALLS PER GAME	3		3	5	3			3	3
22	TILT WARNINGS	2		2	2	2			2	2
23	CREDIT LIMIT	30		30	30	30			30	30
24	ALLOW HIGH SCORES	YES		YES	YES	YES			YES	YES
25	HIGH SCORE AWARD	CREDIT		CREDIT	CREDIT	CREDIT			CREDIT	CREDIT
26	GRND CHMPN AWARDS	1		1	1	1			0	0
27	HIGH SCORE #1 AWARDS	1		1	1	1			0	0
28	HIGH SCORE #2 AWARDS	0		0	0	0			0	0
29	HIGH SCORE #3 AWARDS	0		0	0	0			0	0
30	HIGH SCORE #4 AWARDS	0		0	0	0			0	0
31	GRND CHMPN SCORE	75,000,000		75,000,000	75,000,000	75,000,000			75,000,000	75,000,000
32	HIGH SCORE #1	55,000,000		55,000,000	55,000,000	55,000,000			55,000,000	55,000,000
33	HIGH SCORE #2	40,000,000		40,000,000	40,000,000	40,000,000			40,000,000	40,000,000
34	HIGH SCORE #3	30,000,000		30,000,000	30,000,000	30,000,000			30,000,000	30,000,000
35	HIGH SCORE #4	25,000,000		25,000,000	25,000,000	25,000,000			25,000,000	25,000,000
36	HSTD INITIALS	3 INITIALS		3 INITIALS	3 INITIALS	3 INITIALS			3 INITIALS	3 INITIALS
37	HSTD RESET COUNT	2000		2000	2000	2000			2000	2000
38	FREE PLAY	NO		NO	NO	YES			NO	NO
40	PLAYER LANG. SELECT	YES		YES	YES	NO			YES	YES
45	GAME RESTART	YES		YES	YES	NO			YES	YES
48	BALL SAVE TIME	0:05		0:05	0:05	0:05			0:05	0:05
49	TIMED PLUNGER	OFF		OFF	OFF	OFF			OFF	OFF
50	FLIPPER BALL LAUNCH	OFF		OFF	OFF	OFF			OFF	OFF
51	COINDOOR BALL SAVER	NO		NO	NO	YES			NO	NO
52	COMPETITION MODE	NO		NO	NO	YES			NO	NO
53	CONSOLATION BALL	YES		YES	YES	YES			YES	YES
57	PLAYER COMPETITION	YES		YES	YES	YES			YES	YES
58	TEAM SCORES	NO		NO	NO	NO			NO	NO
63	LOST BALL RECOVERY	YES		YES	YES	NO			YES	YES

* Note: Currently, no Standard Adjustments are changed if Install EXTRA EASY, ... EASY, MEDIUM, HARD, EXTRA HARD, Install HOME PLAY or Install DIRECTOR'S CUT is performed.

SOME INSTALLS MAY CHANGE ADJUSTMENTS NOT NOTED ABOVE WITH FUTURE UPGRADES. YOU CAN ALSO REVIEW OR CHANGE ANY ADJUSTMENT IN THE ADJUSTMENTS MENU (SEE SECTION 3, CHAPTER 4). ADJUSTMENTS WHICH WERE CHANGED ARE NOT NOTED WITH FACTORY DEFAULT ON THE BOTTOM LINE OF THE DOT DISPLAY. THE SETTINGS HIGHLIGHTED ABOVE WILL OVERRIDE ANY MANUAL CHANGES MADE IN THE ADJUSTMENTS MENU.

STANDARD ADJUSTMENTS NOT LISTED ABOVE WHICH NEVER CHANGE WITH ANY INSTALL : 39, 41-44, 46-47, 54-56 & 59-62
INSTALLS MENU continued on the next page.



Overview of Factory Defaults which change with a Particular Install

FEATURE ADJUSTMENTS (ADJUSTMENTS NOT AFFECTED ARE NOT SHOWN) ▼

Nr.	FEATURE ADJUSTMENT NAME	INSTALL FACTORY	INSTALL EXTRA EASY	INSTALL EASY	INSTALL MEDIUM or 3-BALL	INSTALL HARD	INSTALL EXTRA HARD	INSTALL 5-BALL	INSTALL COMPETITION	INSTALL DIRECTOR'S CUT	INSTALL HOME PLAY *
2	POPS AT BALL START	1			1						
3	PINBALL SPELLOUT DIFFICULTY	MEDIUM	EXTRA EASY	EASY	MEDIUM	HARD	EXTRA HARD	HARD		MEDIUM	
4	MINI (PLAYFIELD) CHARM LETTERS SPOTTED	0			0						
5	MINI (PLAYFIELD) MAN LETTERS SPOTTED	0			0						
6	MINI (PLAYFIELD) SHREK LETTERS SPOTTED	0			0						
7	MINI (PLAYFIELD) PUSS LETTERS SPOTTED	0			0						
8	MINI (PLAYFIELD) FIONA LETTERS SPOTTED	0			0						
9	MINI PLAYFIELD MIN. PLAY TIME	15			15				▲ SEE INSTALL HARD ▼		▲ SEE INSTALL MEDIUM ▼
10	MINI PLAYFIELD MAX PLAY TIME	30			30						
11	MINI PLAYFIELD TIME DONKEY INCREMENT	1			1						
12	LETTERS PER MINI PLAYFIELD SHOT	2			2						
14	BURP MULTIBALL DIFFICULTY	MEDIUM	EXTRA EASY	EASY	MEDIUM	HARD	EXTRA HARD			MEDIUM	
15	PUSS IN BOOTS DIFFICULTY	MEDIUM	EXTRA EASY	EASY	MEDIUM	HARD	EXTRA HARD			MEDIUM	
17	POPS CARRYOVER	NO			NO						
18	SWAMP DIFFICULTY	HARD	EASY	MEDIUM	HARD	EXTRA HARD	EXTRA HARD			HARD	
19	LEFT RAMP DIFFICULTY	MEDIUM	EXTRA EASY	EASY	MEDIUM	HARD	EXTRA HARD				
20	BALL SAVER POST TIME	9			9						
21	DRAGON MULTIBALLS	3			3						

Sec. 3: Go To Utilities

* Note: Currently, no Feature Adjustments are changed if Install **COMPETITION**, Install **HOME PLAY**, Install **NOVELTY** or Install **ADD-A-BALL** is performed.

SOME INSTALLS MAY CHANGE ADJUSTMENTS NOT NOTED ABOVE WITH FUTURE UPGRADES. YOU CAN ALSO REVIEW OR CHANGE ANY ADJUSTMENT IN THE **ADJUSTMENTS MENU** (SEE SECTION 3, CHAPTER 4). ADJUSTMENTS WHICH WERE CHANGED **ARE NOT NOTED** WITH **FACTORY DEFAULT** ON THE BOTTOM LINE OF THE DOT DISPLAY. THE SETTINGS HIGHLIGHTED ABOVE WILL OVERRIDE ANY MANUAL CHANGES MADE IN THE ADJUSTMENTS MENU.

FEATURE ADJUSTMENTS NOT LISTED ABOVE WHICH NEVER CHANGE WITH ANY INSTALL : **1, 13, 16, 22 – 25**





Enter Custom Message

To initiate, from the **UTILITIES MENU**, select the "ABCD CUST MSG" *Icon*. The **SET CUSTOM MESSAGE** (a short-cut for Standard Adjustment **41, Custom Message**) provides an opportunity to have a text message appear in the the **Attract Mode**. Follow the on-screen prompts to complete [END].

Remember, use the **GREEN Button** to go [**BACK**], exit or escape, the **RED Buttons** to [**</-**] MOVE LEFT / CHOOSE NEXT [**+/>**] MOVE RIGHT / CHOOSE PREVIOUS, and the **BLACK Button** to [**SELECT**] as 'OK'.



Set Custom Pricing

To initiate, from the **UTILITIES MENU**, select the "PRIC" *Icon*. The **CUSTOM PRICING MENU** (a short-cut for Standard Adjustment **18, Game Pricing**, and setting selected is **CUSTOM**) provides an opportunity to set **Custom Pricing**.

Note ! MONETARY AMOUNT MUST BE SELECTED FIRST! Press [**BACK**] to - DECREASE or [**SELECT**] to + INCREASE the [**< \$ >**] monetary amount (e.g. look at the right side of the display from **\$0.25** to **\$0.50**). Press [**</-**] to - DECREASE or [**+/>**] to + INCREASE the **credit quantity** (e.g. look at the left side of the display from **0 CREDITS AT:** to **1 CREDIT AT:**).

IF EXAMPLE CUSTOM PRICING SETTING DESIRED IS :

1 Play for \$0.50, 3 Plays for \$1.00 and 7 Plays for \$2.00

THEN YOU WILL NEED TO PERFORM THE FOLLOWING :

REMINDER

In these menus:

Press [**BACK**] to - DECREASE [**< \$**]

Press [**SELECT**] to + INCREASE [**\$ >**]

Step 1 The starting display appears as below if no prior **Custom Pricing** was installed.



Step 2 Press [**SELECT**] to + INCREASE to **\$0.50**. Press [**+/>**] to + INCREASE to 1 CREDIT AT:

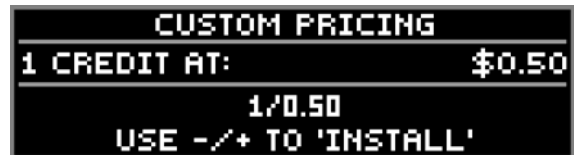

Step 3 Press [**SELECT**] to + INCREASE to **\$1.00**. Press [**+/>**] to + INCREASE to 2 CREDITS AT:

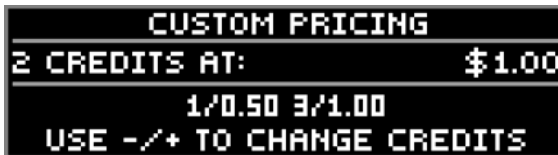

Step 4 Press [**SELECT**] to + INCREASE to **\$2.00**. Press [**+/>**] to + INCREASE to 4 CREDITS AT:

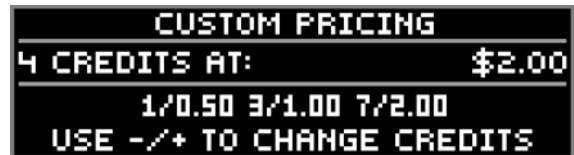

Step 5 Press [**SELECT**] to + INCREASE the amount once (example = **\$2.25**). Press [**</-**] once ...

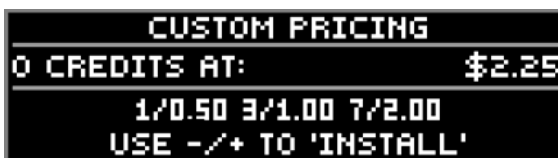

Step 6 Press [**SELECT**] to **INSTALL**. Press [**</-**]/[**+/>**] or [**BACK**] to edit.

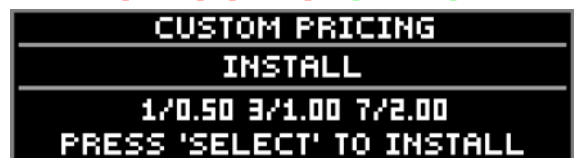

... or press [**+/>**] eleven times until **INSTALL** appears.

Step 7 Press [**SELECT**], press [**BACK**] twice to exit the **SERVICE MENU** with your **Custom Pricing** installed.



To correct or make new changes, reenter, which brings you to **Step 6**. Press [**BACK**] repeatedly until the monetary amount shown is the desired amount and then continue following the above steps with your new or corrected settings. *If you are still having difficulty or if you have any questions, please call Technical Support 800-542-5377 or 708-345-7700, option 1.*



Set Date / Time

To initiate, from the **UTILITIES MENU**, select the "TIME" *Icon*. The **SET TIME MENU** appears with the **MONTH** flashing. Setting the date and time is required for 'Data Dumps' and Tournament Start and End Dates. If the setting of Standard Adjustment **61, Time Format**, is set to **12-HOUR** (*Factory Default*) the time will be expressed in the **AM / PM format**. If Standard Adjustment **61, Time Format**, is set to **24-HOUR** the time will be expressed in the **24-hour format**.



Go To Resets Menu

To initiate, from the **UTILITIES MENU**, select the "RESET" *Icon*. The **RESETS MENU** provides six (6) functions to reset *only the Coin Audits*, reset *only the Game Audits*, reset *only the Grand Champion Score*, reset *only the High Score(s)*, reset *only the paid Credits (includes Service Credits)* or to reset **ALL DATA** back to the **Factory Default Settings**.



Reset Coin Audits

To initiate, from the **RESET MENU**, select the "COIN" *Icon*. **⚠ ONLY the Coin Audits** [Earnings Audits **5-12**], will be reset to zero (0), *Factory Default Settings*. Follow the on-screen prompts to perform the **Reset**.



Reset Game Audits

To initiate, from the **RESET MENU**, select the "AUD" *Icon*. **⚠ ONLY the Game Audits** [Earnings Audits **1-4**, Standard Audits **1-59** and Feature Audits **1-XX***], will be reset to zero (0), *Factory Default Settings*. Follow the on-screen prompts to perform the **Reset**. *varies per game title.



Reset Grand Champion (Score)

To initiate, from the **RESET MENU**, select the "GC" *Icon*. **⚠ ONLY the Grand Champion Score** [adjustable via Standard Adjustment **31**], will be reset to *Factory Default Setting*. Follow the on-screen prompts to perform the **Reset**.



Reset High Scores

To initiate, from the **RESET MENU**, select the "HSTD" *Icon*. **⚠ ONLY the High Score(s)** [adjustable via Standard Adjustments **32-35**], will be reset to *Factory Default Setting(s)*. Follow the on-screen prompts to perform the **Reset**. **Note:** *High Scores (but not Grand Champion Score) are reset automatically every 2,000 games (Factory Default Setting) [adjustable via Standard Adjustment **37, HSTD Reset Count**]*.



Reset Credits

To initiate, from the **RESET MENU**, select the "CRED" *Icon*. **⚠ ONLY the Credits (includes Service Credits)** [adjustable via Standard Adjustment **23, Credit Limit**], will be reset to zero (0), *Factory Default Settings*. Follow the on-screen prompts to perform the **Reset**.



Reset Factory Settings

To initiate, from the **RESET MENU**, select the "FACT" *Icon*. **⚠ ALL GAME DATA IS RESET!** (*with the exception of Earnings Audit **13**, Software Meter*). **NOTE: IF YOU HAD SET-UP CUSTOM PRICING OR HAD CHANGED ANY ADJUSTMENTS OR PERFORMED INSTALLS, IT IS SUGGESTED TO WRITE DOWN YOUR CHANGES PRIOR TO THE FACTORY RESET.** Follow the on-screen prompts to perform the **Reset**.



Go To USB Menu

To initiate, from the **UTILITIES MENU**, select the "USB" *Icon*. The **USB MENU** provides three (3) functions to download game data, update your game code or backup your code onto a USB Memory Stick. *Review the inside cover for information on how to update your game code.*



Dump to USB Memory Stick

To initiate, from the **USB MENU**, select the "DUMP" *Icon*. Follow the on-screen prompts to perform a **Data Dump** (download).



Update Game Code

To initiate, from the **USB MENU**, select the "UPDT" *Icon*. Follow the on-screen prompts *or review the inside cover for more information.*



Backup to USB Memory Stick

To initiate, from the **USB MENU**, select the "BKUP" *Icon*. Follow the on-screen prompts to perform a **Backup** (game code only). This backup feature does not retain adjustments and/or settings changes made.

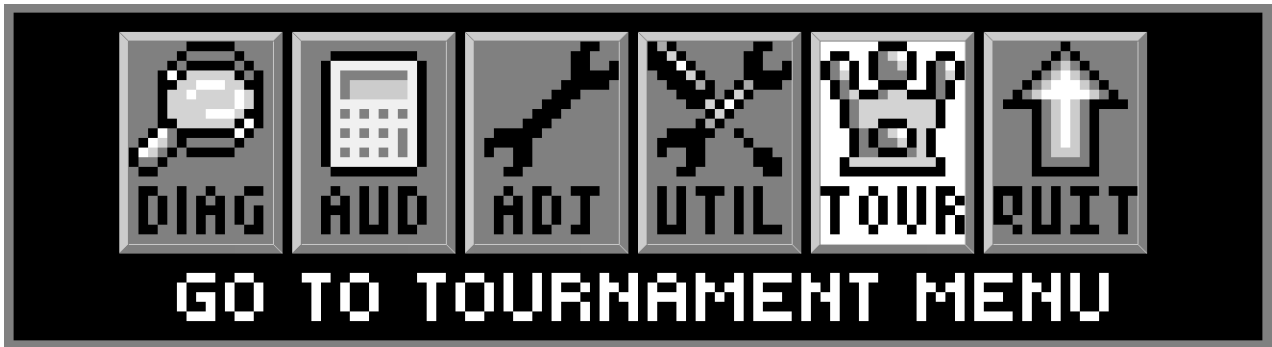

To initiate, from the **MAIN MENU**, select the "TOUR" *Icon*. The **TOURNAMENT MENU** provides ways to quickly and easily start and stop a tournament. Also, tournament data can be viewed (*audits, prize info, etc.*).

All **TOURNAMENT MENU** *Icons* and their usages are explained throughout this chapter in the same order as seen in the Dot Matrix Display. **NOTE:** Depending on Game Type, Version, selections made, Dip Switch settings, location and/or areas, some *Icons* may appear non-functional or may not appear at all. **Icons and/or functions, order and operation are subject to change.**

In displays where changes can be made or to perform a function, use the **GREEN Button** to go [**BACK**], exit or escape, the **RED Buttons** to [**</-**] HIGHLIGHT PREVIOUS or DECREASE / [**+ / >**] HIGHLIGHT NEXT or INCREASE to highlight the desired option, and the **BLACK Button** to [**SELECT**] it or activate.



Start Tournament

To initiate, from the **TOURNAMENT MENU**, select the "STRT" *Icon*. The **START TOURNAMENT MENU** allows the operator to start a tournament. Select **QUICK START** or **CUSTOM** Tournament Start. For the first time Tournament Set-Up, it is recommended to select **CUSTOM**. Follow the on-screen prompts.

After completion of all options in **QUICK START** or **CUSTOM**, the Tournament is started, the **START TOURNAMENT MENU** is exited and returns to the **TOURNAMENT MENU**.

QUICK START :

Increase or decrease the: • **DAYS, HOURS and MINUTES** • **PRIZE POOL \$ (DOLLAR) and ¢ (CENT) AMOUNT**
• **INCREMENT THE PRIZE POOL PER PLAY INCREASES \$ and ¢ AMOUNT**

CUSTOM START :

- Confirm the current date and time (*if it was not set previous via the UTILITIES MENU it can be set-up in this display as well*). Enter the **MONTH, DAY, YEAR** and **TIME**
- Choose the Tournament **Start Date: MONTH, DAY, YEAR** and **TIME**
- Choose the Tournament **End Date: MONTH, DAY, YEAR** and **TIME**
- Choose the **CREDITS** per play desired (01-10). Set the maximum number of *Credits* that may be accumulated per game. **Note:** *The current pricing is displayed; to change pricing GO TO THE ADJUSTMENTS MENU.*

Increase or decrease the: • **PRIZE POOL \$ (DOLLAR) and ¢ (CENT) AMOUNT**
• **INCREMENT THE PRIZE POOL PER PLAY INCREASES \$ and ¢ AMOUNT**
• **MAXIMUM (CAP) PRIZE POOL \$ and ¢ AMOUNT.**

- Increase or decrease the number of **PRIZES** (01-05 **HIGH SCORE**; 02-05 **B'N'W**). Set the maximum # of *Prize Positions* to be awarded during a Tournament. **Selections are as follows** (*% distribution cannot be changed*):

		HIGH SCORE:					BUMP N' WIN :																
Set to 01	1 Winner	100%	(1)	Prize Pool	Cannot set to 01. Minimum of 2 winners required.																		
Set to 02	2 Winners	65%	(1)	35%	(2)	Set to 02	2 Winners	65%	(1)	35%	(2)												
Set to 03	3 Winners	50%	(1)	30%	(2)	20%	(3)	Set to 03	3 Winners	50%	(1)	25%	(2)	25%	(3)								
Set to 04	4 Winners	50%	(1)	25%	(2)	15%	(3)	10%	(4)	Set to 04	4 Winners	40%	(1)	20%	(2)	20%	(3)	20%	(4)				
Set to 05	5 Winners	50%	(1)	20%	(2)	15%	(3)	10%	(4)	5%	(5)	Set to 05	5 Winners	40%	(1)	15%	(2)	15%	(3)	15%	(4)	15%	(5)

- Select the **AWARD TYPE** (**CASH, POINTS, PRIZE, TICKETS** or **NONE**). Select **CASH** for the displays to represent the Prize Pool amount (*based on Jackpot Base and Max.*) in **\$Dollars**. Select **POINTS** for the display to represent the Prize Pool amount in **Points**. Select **PRIZE**, if applicable. Select **TICKET** for the display to represent the Prize Pool amount in **Tickets**. Select **NONE NOT TO** represent anything.

Custom Start continued on the next page.

CUSTOM START Continued.

The following option is available only if **CASH** was selected as the **AWARD TYPE**.

- Select the option to **SHOW PLAYER CASH** (YES or NO). Select **YES** for the display to represent the >>> **previous** <<< Tournament Winners & Cash amount (or Points, Prizes, etc.) will show in the **Attract Mode**.
- Select the kind of **TOURNAMENT** desired (BUMP 'N' WIN or HIGH SCORE).

The following options are available only if **BUMP 'N' WIN** was selected as the **TOURNAMENT TYPE**.

- Select or confirm the **BASE POINT AMOUNT** (00 or 1,000,000 – 4,294,967,295 increments of 1,000,000).
- Select or confirm the **RANGE AMOUNT** (00 or 1,000,000 – 4,294,967,295 increments of 1,000,000).
- Select the **BALLS** per game (1 – 10).



STOP TOURNAMENT

To initiate, from the **TOURNAMENT MENU**, select the "STOP" *Icon*. The **STOP TOURNAMENT MENU** allows the operator to stop a tournament. **Note:** This *Icon* only appears if a Tournament was set-up and is running (in place of the Start *Icon*).

STOP TOURNAMENT ARE YOU SURE?

- Use the **BLACK Button** to [**SELECT**] to confirm. Press the **BLACK Button** again to continue.

The **STOP TOURNAMENT MENU** is exited and returns to the **TOURNAMENT MENU**.



VIEW TOURNAMENT DATA

To initiate, from the **TOURNAMENT MENU**, select the "DATA" *Icon*. If no data is available, the display will indicate NO PREVIOUS DATA. Press the **GREEN Button** to escape [**BACK**] to the **TOURNAMENT MENU**.



TOURNAMENT AUDITS [#1 – #14]

To initiate, from the **TOURNAMENT MENU**, select the "AUD" *Icon*. The Dot Matrix Display will indicate the *audit number (in this group)*, *audit name* and the *audit total or value*. The current audit will remain on the display until the next audit is viewed or when this sub-menu is exited.

- | | |
|----|---|
| 01 | TOTAL PLAYS : Total number of <i>Regular</i> and <i>Tournament Games</i> played while a <i>Tournament</i> is in progress. This total is derived by adding the below <i>Tournament Audit 02</i> with Regular Plays . |
| 02 | TOURNAMENT PLAYS : Total number of <i>Tournament Games</i> played while a <i>Tournament</i> is in progress. |
| 03 | TOTAL QUALIFYING PLAYS : Total number of times a player qualified (<i>invited to enter name</i>). |
| 04 | TOTAL GAME EARNINGS : Total Gross Earnings <i>accepted</i> , while a <i>Tournament</i> is active (<i>in progress</i>). |
| 05 | TOTAL TOUR. EARNINGS : <i>Tournament Earnings (Audit 04 less Reg. Game Earnings)</i> while a <i>Tournament</i> is in progress. |
| 06 | JACKPOT (PRIZE POOL TOTAL) : Total Prize Pool (<i>Jackpot</i>) Amount to be paid out while a <i>Tournament</i> is in progress. |
| 07 | NET EARNINGS : Provides the total Net Earnings (<i>Gross Earnings less Prize Pool</i>) while a <i>Tournament</i> is active (<i>in progress</i>). |
| 08 | ACCUM. TOTAL PLAYS : Accumulative total amount of <i>Regular & Tourn. Games</i> played since the first <i>Tournament</i> was played. |
| 09 | ACCUM. TOUR. PLAYS : Accumulative total amount of <i>Tournament Games</i> played since the first <i>Tournament</i> was played. |
| 10 | ACCUM. QUALIFYING PLAYS : Accumulative total number of times a player qualified (<i>invited to enter name</i>). |
| 11 | ACCUM. EARNINGS : Total Gross Earnings <i>accepted</i> , since the first <i>Tournament</i> was played. |
| 12 | ACCUM. TOUR EARNINGS : Accumulative total <i>Tournament Game Earnings</i> since the first <i>Tournament</i> was played. |
| 13 | ACCUM. JACKPOT : Accumulative total of Prize Pool (<i>Jackpot</i>) Amounts paid out since the 1st <i>Tourn.</i> was played. |
| 14 | # TOURNAMENTS : Number of <i>Tournaments (not individual Tournament Games)</i> since the first <i>Tournament</i> was played. |



SIGN MESSAGES A-B

To initiate, from the **TOURNAMENT MENU**, select the "A-B TEXT" *Icon*. *At time of print, menu non-functional. If made available in future code updates, this menu will allow the operator to display "Location" and "Prize" Messages.* Follow the on-screen prompts to complete [**END**].

Remember, use the **GREEN Button** to go [**BACK**], exit or escape, the **RED Buttons** to [**< / -**] MOVE LEFT / CHOOSE NEXT [**+ / >**] MOVE RIGHT / CHOOSE PREVIOUS, and the **BLACK Button** to [**SELECT**] as 'OK'.

Parts Identification & Location (The Pink Pages)

Table of Contents for Section 4, Chapter 1 of 2

Table of Contents for Section 4, Chapter 1	41
Backbox [S.A.M. System] - Parts □	42 – 43
▷ Backbox & Tournament Header Sign Front Views ▷ Backbox Parts Table ▷ Backglass Parts Table	
Speaker Panel [S.A.M. System] - Parts □	43
▷ Speaker Panel Side View ▷ Speaker Panel Parts Table	
Cabinet - Parts ■ & Switches □	44 – 45
▷ Cabinet Inside Views ▷ Cabinet Parts & Switches Table	
Playfield Top - Miscellaneous Parts □ & Brackets ■	46
▷ Playfield Location & Bottom Arch Drawings ▷ Misc. Parts (Above) Table ▷ Misc. Brackets (Above) Table	
Playfield Bottom - Miscellaneous Parts ■ & Brackets ■	47
▷ Playfield & Back Panel Location Drawings ▷ Misc. Parts (Below) Table ▷ Misc. Brackets (Below) Table	
Playfield Top - Switches (Above) □	48
▷ Playfield Location Drawing	
Playfield Top - Switches (Below) ■	49
▷ Playfield Location Drawing	
Playfield Top - Flat Rails □, Wood Rails ■, Ball Guides ■ & Wire Forms ■	50
▷ Playfield Location Drawing ▷ Flat Rails Table ▷ Wood Rails Table ▷ Ball Guides Table ▷ Wire Forms Table	
Playfield Top - Plastics (Screened & Clear) Kit, Decals & Mylar Kits	51
▷ Plastic Shape & Decal Art Drawings	
Playfield Top & Bottom - Metal Posts □ & Fin Shank Screws ■ (Actual Size)	52 – 53
▷ Metal Posts & Fin Shank Screw Drawings ▷ Metal Posts Table ▷ Fin Shank Screws Table ▷ Playfield Location Drawing	
Playfield Top & Bottom - Nylon Stop, KEPS, Hex, T-, Flange, Pal & Wing Nuts (Actual Size)	53
▷ Nylon Stop Nuts Table ▷ Keps Nuts Table ▷ Hex Nuts Table ▷ T-Nuts Table ▷ Flange Nuts Table ▷ Pal Nuts Table	
▷ Wing Nuts Table	
Playfield Top - Hex Spacers □ (Actual Size)	54 – 55
▷ Hex Spacers Drawings ▷ Hex Spacers Table ▷ Playfield Location Drawing	
Playfield Top - Plastic Posts & Spacers □ & Metal Spacers ■	56 – 57
▷ Plastic Posts & Spacers Drawings ▷ Plastic Posts & Spacers Table ▷ Playfield Location Drawings	
Playfield Top & Bottom - Rubber Parts Black ■ & White □ (Rings Actual Size)	58 – 59
▷ Rubber Parts Drawings ▷ Rubber Bumper Pads Table ▷ Rubber Bumper Post Sleeves Table ▷ Rubber Rings Table	
▷ Playfield Location Drawing(s)	
Playfield Top & Bottom - Small Bayonet Sockets & Bulbs ■ (Actual Size)	60 – 61
▷ Bulbs & Socket Drawings ▷ Bulbs (#44 / LED & #455) Table ▷ Small Bayonet Sockets Table	
Playfield Bottom - Large Bayonet Sockets & Bulbs ■ (Actual Size)	61
▷ Bulbs & Socket Drawings ▷ Bulbs (#89) Table ▷ Large Bayonet Sockets Table	
Playfield Top & Bottom - Wedge Base Sockets & Bulbs ■ (Actual Size)	62
▷ Bulbs & Socket Drawings ▷ Bulbs (#555 & LED / #906) Table ▷ Wedge Base Sockets Table	

Backbox [S.A.M. System] - Parts

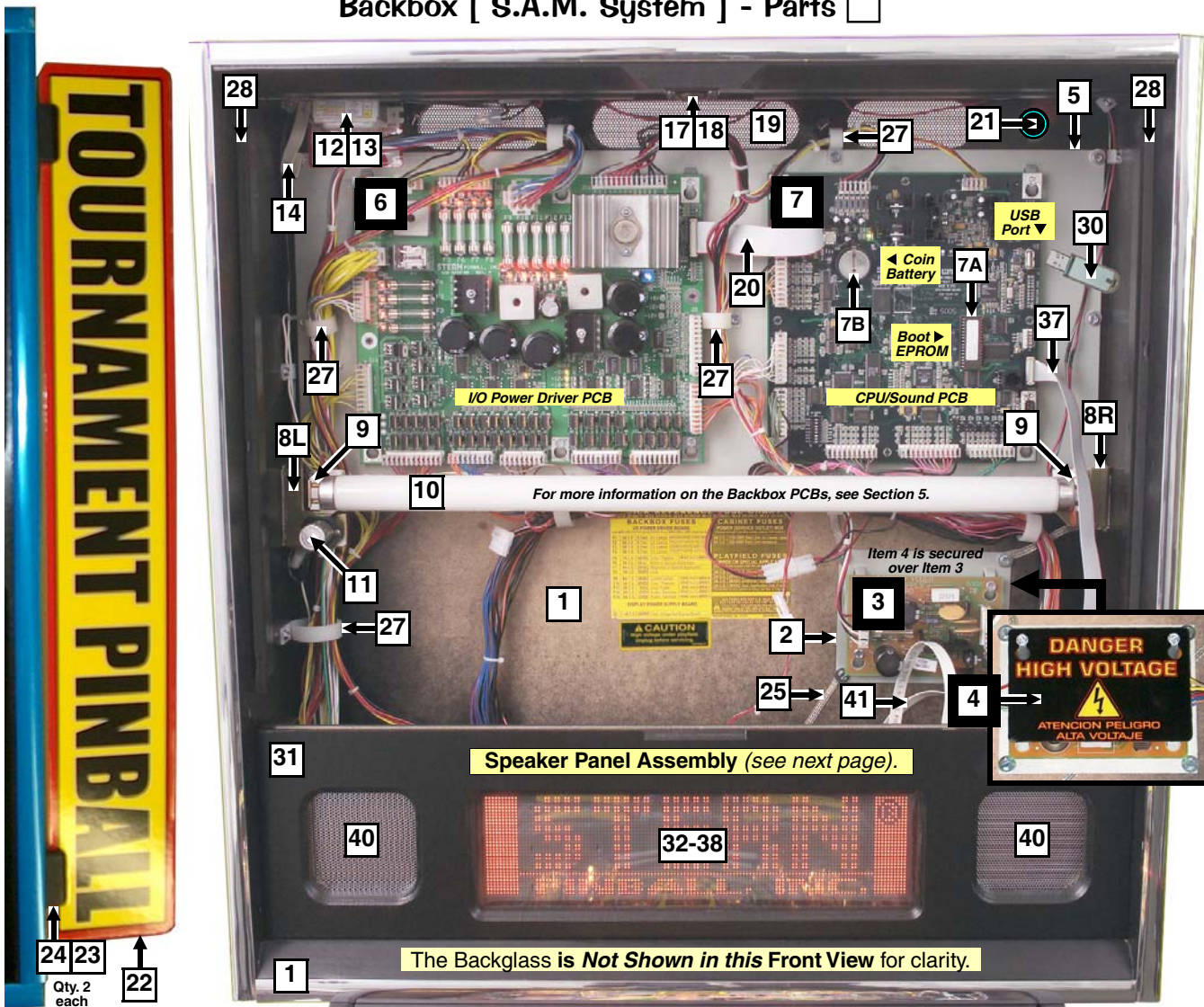

Sec. 4: Parts Id. ...

Nr.	BACKBOX PARTS	QTY.	SPI PART Nr.	Nr.	BACKBOX PARTS	QTY.	SPI PART Nr.
1	Backbox Shrek® (No Parts)	1	525-5631-17-A5	11	Starter - Fluorescent (FS2 Light)	1	165-5011-01
<i>Item 1 Note: Chrome T-Molding is installed and cannot be ordered separately. Fuse Description (820-6384-00) and Risk of Electrical Shock - (UL) (820-6082-03) Decals.</i>				11	Starter Base (with leads) [on Item 8L]	1	077-5213-00
2	PCB Metal Mounting Plate [Display]	1	535-9769-00	Item 11 is secured to Item 8L by: #4-40 X 1/2" PPH MS (Sems) Zc. (Qty. 2) (237-5813-00)			
3	Display Power Supply PCB	1	520-5138-00	12	Ballast Mounting Plate	1	535-8657-00
Item 3 is secured to @ bottom by: #8-32 X 3/8" SHWH Swg. (Zinc) (Qty. 2) (237-5975-00)				13	Ballast CU452-W 1/2" Core 120v 60 Hz 13W	1	010-5015-00
4	Plastic Cover [DANGER HIGH VOLTAGE]	1	830-6053-00	Items 12 & 13 are secured to Item 1 by: #6 X 5/8" SHWH AB (Zc) (Qty. 2) (234-5102-04) >>> CAUTION - VERY HOT" Decal (820-6266-00) EU / UK Only : Ballast, 5/8" Core 50/60 Hz (010-5015-01)			
Items 3 & 4 are secured to @ top by: 1-1/4" X 3/8" Plastic Spacer Gray (Qty. 2) (254-5000-05) and #8-32 X 1-3/4" SHWH Ser. (Zinc) (Qty. 2) (237-5975-28)				14	Ground Strap (5")	1	600-5006-05
5	PCB Metal Mounting Plate [I/O+CPU]	1	535-9664-00	15*	Roto Lock Male (on Cabinet)	1	355-5006-01
Items 2 & 5 are secured to Item 1 by: #8 X 1/2" SHWH AB (Zinc) (Qty. 1/hole) (234-5101-00) and #10 Washer 7/32" I.D. X .5" O.D. X 1/16" Thick (Qty. 1/hole) (242-5003-00) Note: Where a Wire Clamp (Item 27) is mounted, a #10 Washer is not required.				16	Roto Lock Female (R2-0002-02)	1	355-5006-02
6	I/O Power Driver PCB [S.A.M. Sys.]	1	520-5249-00	Item 16 is secured by: #10-24 X 1-3/4" CBSN (231-5022-00), #10-24 Keps Nut (Qty. 2) (240-5207-00), #10-24 X 2" CBSN (231-5045-00), #10-24 Keps Nut (240-5207-00) and #10 Washer 7/32" I.D. X .5" O.D. X 1/16" (Qty. 5) (242-5003-00); See opposite next page.			
7A: 8MB EPROM #M27C801-100F1 (960-5016-00) Ordering Note: Programmed EPROM (965-BOOT-SAM) 7B: Coin Cell Battery (CR2430 3V) (000-0644-01) For USB Memory Stick Information, see Item 30 on the next page.				17	Lock Mounting Plate	1	535-0072-00
7	CPU/Sound PCB [S.A.M. System]	1	520-5246-00	18	Lock 5/8" Barrel, 3/4"Ø, 1.5" Flat Cam	1	355-5055-00
Items 6 & 7 are secured to Item 5 by: #8-32 X 3/8" HWH MS (Qty. 10) (237-5903-00) and 1/4" Sft. Rtn. Plastic Spacer White (Qty. 5 [I/O] / Qty. 4 [CPU]) (254-5007-05)				Items 17 & 18 are secured by: #8 X 1/2" TP Torx T20 Black (Qty. 2) (237-6173-05)			
8L	Fluorescent Light Bracket (Left Style)	1	535-7739-00	19	Back Vent Grill 2-1/2" X 18"	1	545-5072-02
8R	Fluorescent Light Brckt. (Right Style)	1	535-7739-01	20	Ribbon Cable, 20-Pin (3.5")	1	036-5000-350
Items 8L & 8R are secured to Item 1 by: #10-24 X 1-1/4" Carriage Bolt Square Neck (Qty. 2/per) (231-5012-00), #10-24 Keps Nut (Qty. 2/per) (240-5207-00) and 3/4" X 3" Reinforced Strapping Tape (Qty. 1, sold in 12" length only) (626-5040-00)				Item 20 connects the I/O Pwr. Drvr. PCB to the CPU/Sound PCB; For 14-Pin see next page.			
9	Fluorescent Lamp Holder (Socket)	2	077-5214-01	21	Button Hole Plug (Blk) (Happ #52-6214-00)	1	500-6566-00
Item 9 is secured to Items 8L and 8R by: #6-32 X 5/8" PPH MS (Sems) Zinc (Qty. 1/per) (232-5203-00) Lock-In Fluor. Bulb with Yellow Socket Clip (Qty. 1/per) (545-6271-00)				22	Header Sign TOURNAMENT PINBALL	1	545-6133-00
10	Fluorescent Tube 24" (F20T9CW)	1	165-5061-00	23	Friction Hinge (Black) behind ▲▼	2	390-5053-00
				24	Block / Sign & Hinge Stop (Black)	2	545-6174-00
				Item 22 is sandwiched between Items 23 & 24 through 2 holes on each side. Item 23 is secured to Item 1 by: #8-32 X 3/8" PPH MS Ext. Sems (Zinc) (Qty. 2/per) (232-5301-00) and Item 24 to Items 22-23 by: #8 X 5/8" PPH AB Black (Qty. 2/per) (232-5101-01)			

PARTS TABLE & VIEWS CONTINUED ON THE NEXT PAGE. ▶



Backbox [S.A.M. System] - Parts

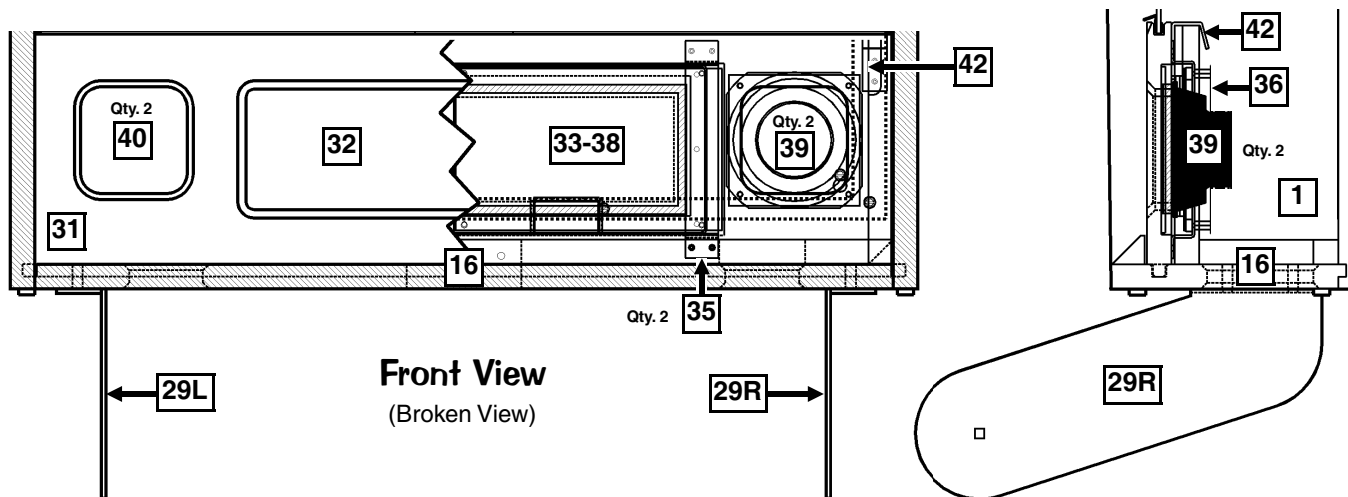

Speaker Panel [S.A.M. System] - Parts

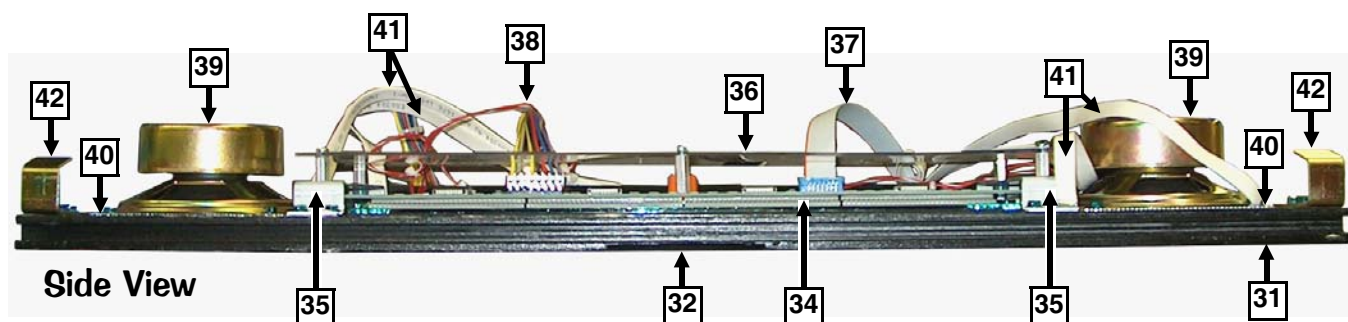

Nr.	BACKBOX PARTS	QTY.	SPI PART Nr.	Nr.	SPEAKER PANEL PARTS	QTY.	SPI PART Nr.
<p>← PARTS TABLE & VIEWS CONTINUED FROM THE PREVIOUS PAGE.</p>							
25	Braided Wire (1-1/2 Feet)	1	600-5001-00	31	Speaker Panel (Black Wood)	1	525-5515-00
Item 25 is secured by: Staple 5/16" (Qty. 23) (631-5000-00)				32	Plastic Shield (Display Front Cover)	1	545-5884-00
26*	Zip Cable Tie (Screw Down Style)	2	040-5005-00	Item 33 is secured to inside Item 31 by: #6 X 3/8" SHWH AB (Zinc) (Qty. 8) (234-5000-00)			
Item 26 is secured @ inside bot. by: #8 X 1/2" SHWH AB (Zinc) (Qty. 1/per) (234-5101-00)				33*	Foam 3/16" Thick X 1/4" Wide X 12"	3	626-5026-00
Item 27 secured by: #8 X 1/2" SHWH AB (Zinc) (Qty. 1/per) (234-5101-00)				Above Item 33 is self-adhesive. Located between Items 32-34. Sold in 12" Lengths only.			
27	Clamps [Multiple Sizes]	15	040-5000-XX	34	128 X 32 Dot Matrix Display PCB	1	520-5052-00
For following sizes, replace -XX with: 1/4" Double = -23 (Qty. 5); 1/2" Single = -06 (Qty. 1); 3/4" Single = -08 (Qty. 3); 1" Single = -09 (Qty. 1); 1-1/4" Double = -30 (Qty. 2)				Item 34 is secured to Item 35 by (at corners): 3/16" X 3/8" Spacer Gray (Qty. 4) (254-5000-18) and #6-32 X 1/2" SHWH Swage (Serr) Zinc (Qty. 4) (237-5976-03)			
28	Foam 3/16" Thick X 1/4" Wide X 12"	3	626-5026-00	35	Dot Matrix Display Mounting Bracket	2	535-8368-01
Above Item 28 is self-adhesive. 17.5" strip on each side. Sold in 12" Lengths only.				Item 35 is secured to Item 31 by: #8 X 1/2" SHWH AB (Zinc) (Qty. 4/per) (234-5101-00)			
29L	Pivot Hinge (Left) Shrek® Green	1	535-7999-08	36	Plastic Shield (Display Back Cover)	1	830-6040-00
29R	Pivot Hinge (Right) Shrek® Green	1	535-7999-09	Item 36 is secured to Item 34 by: 1/2" X 1/4" Hex Spacer #6-32 Tap (Qty. 4) (254-5008-03), 3/4" X 1/4" Hex Spacer #6-32 Tap (Qty. 2) (254-5008-04), #6-32 X 1/4" PPH MS (Sems) Zinc (Qty. 2) (232-5200-00) and #6-32 X 3/8" PPH (Qty. 6) (232-5201-00)			
Items 29L-29R are secured to Backbox by: 1/4"-20 X 1-1/4" C.B. Sq. Neck (Qty. 4) (231-5003-00) and 1/4"-20 Flange Nut (Qty. 4) (240-5300-00)				37	Ribbon Cable, 14-Pin (32")	1	036-5260-32
Items 29L-29R are secured to Cabinet by: Spacer Hex Nut 1/2" O.D. - 1/4-20 X 1/2" TD (Black) (Qty. 1/per) (254-5042-00), Nylon Spacer (Black) (Qty. 1/per) (242-5084-00), 1/4-20 X 1/2" Carriage Bolt Square Neck (Zinc) (Qty. 1/per) (231-5072-01) and Washer 1" O.D. X 1/2" I.D. X 1/16" (Black) (Qty. 1/per side, only if required) (242-5087-00)				Item 37 (14-Pin) connects the 128 X 32 Dot Matrix Display PCB to the CPU/Sound PCB.			
30*	Memory Stick USB 1.1+ [Generic] 64MB		970-0064-00	38	Display Cable (Wiring Harness)	1	036-5454-01
Item 30 was not included with your game. Read the inside cover or go on-line for more info. To order with the latest game code copied onto it, add -A5 to the Part Nr. (970-0128-00-A5). File(s) can be downloaded from our website (Files are 25MB or larger, DSL or Fast Modern recommended). Not all manufacturers of Memory Sticks are compatible with our system. Test it out, if it doesn't work properly, return your purchase and order the memory stick through you local pinball distributor (Stern Pinball Memory Sticks guaranteed compatible).				Item 38 (14-Pin) connects the 128 X 32 Dot Matrix Display PCB to the CPU/Sound PCB.			
(ASM. REF. 505-6002-A5-A5, Items 1-42 Only, [29-30 not included in assembly])				39	Speaker (Shld.) 4" 8Ω #MG ELE 4060SH	2	031-5004-02
Take Note:				40	Speaker Grill (Chrome w/no Artwork)	2	535-8081-04
* An asterisk (*) indicates item(s) are not noted in the pictorials.				Items 39-40 are secured by: #8 X 1/2" SHWH AB (Black) (Qty. 4/per) (234-5101-01)			
				41	Ground Strap (25") [2 per : Items 35 & 39]	4	600-5006-25
				42	Speaker Panel Hook Bracket	2	535-7009-02
				Item 42 is secured by: #8 X 1/2" SHWH AB (Zinc) (Qty. 2/per) (234-5101-00)			
				(ASM. REF. 515-6888-05, Items 31-42 Only [includes wiring])			

Nr.	BACKGLASS PARTS	QTY.	SPI PART Nr.	Nr.	BACKGLASS PARTS	QTY.	SPI PART Nr.
i*	Clear Backglass 25.906" X 19.187"	1	660-5038-02	iv*	Bottom Plastic Lift Channel - 26-1/16"	1	545-5021-01
ii*	Shrek® Film Art (#A5)	1	830-52A5-00	v*	Plastic Edging (Left/Right) - 18-1/8"	2	545-5018-14
iii*	Top Plastic Channel - 26"	1	545-5018-15	Items i-v are secured to Item i by: Taple (Double-Sided), 12" (Qty. 1) (626-5005-00)			
				Note: Only 6" required, sold in 12" lengths only.			
				(ASM. REF. 515-5450-00-A5, Items i-v)			

Cabinet - Parts & Switches

For Backbox Parts see the previous two pages.

Cabinet color and design shown is for reference only. Actual photo of game is on the Shrek Brochure. Side Armor (9L/R), Front Molding (10) & Legs (2) shown black are actually green.

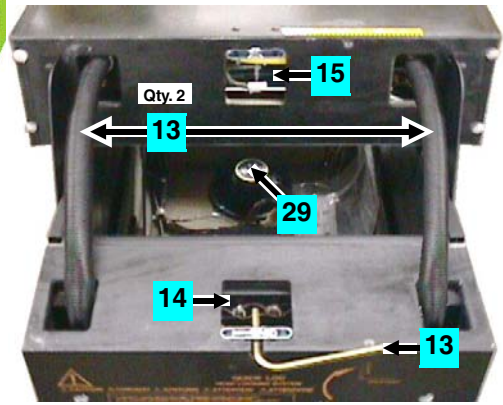
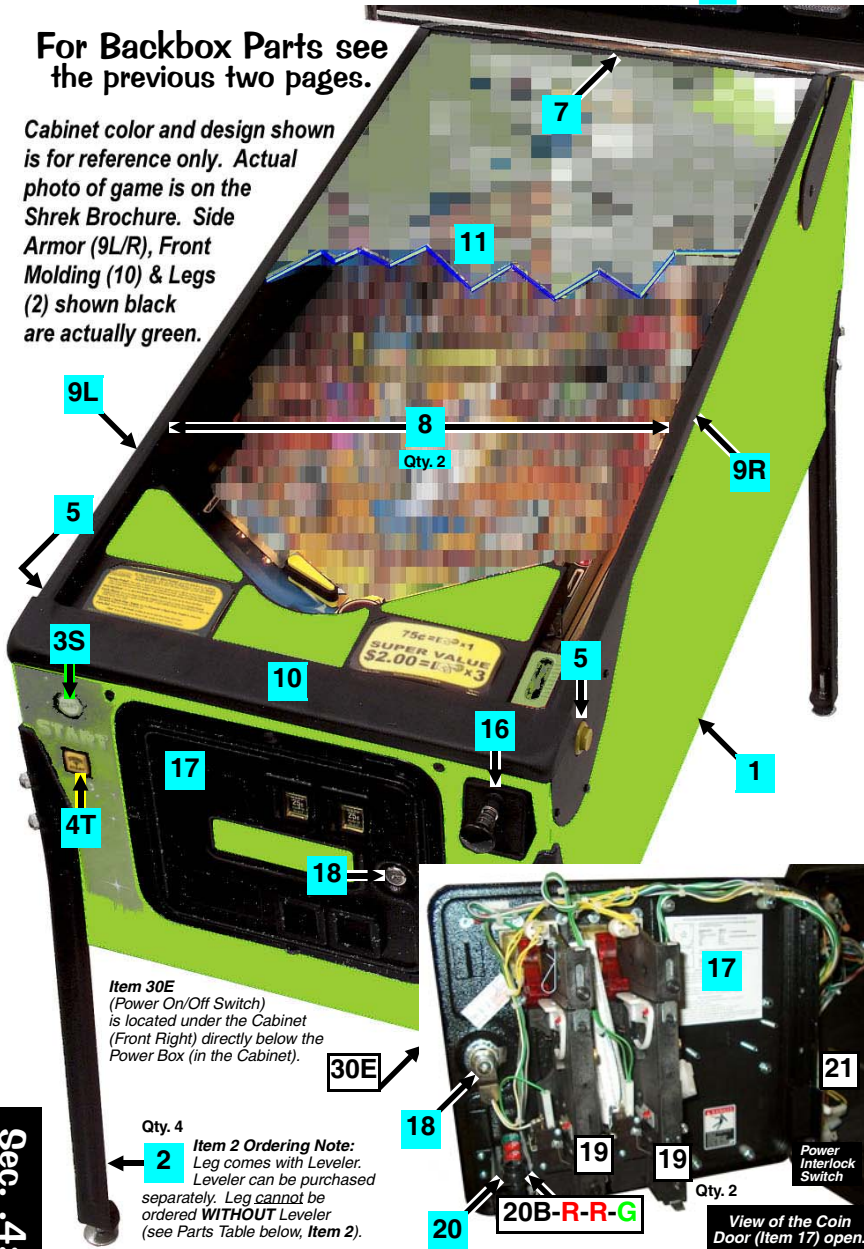

Take Note:

* An asterisk (*) indicates item(s) are not noted in the pictorials.

Legend Note: Items noted with a cyan square ■ are Cabinet Parts. Items noted with a white square □ are Switches.

Item 30E (Power On/Off Switch) is located under the Cabinet (Front Right) directly below the Power Box (in the Cabinet).

Qty. 4
2 Item 2 Ordering Note: Leg comes with Leveler. Leveler can be purchased separately. Leg cannot be ordered WITHOUT Leveler (see Parts Table below, Item 2).

Sec. 4: Parts Id. ...

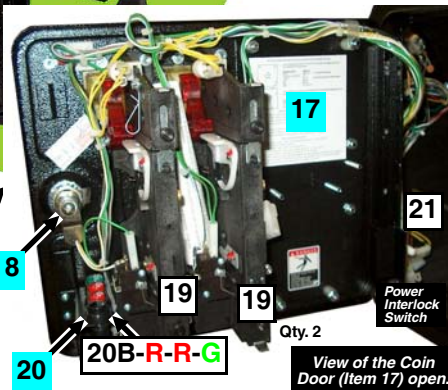

Nr.	CAB. PARTS & SWITCHES	QTY.	SPI PART Nr.
1	Screened Cabinet Shrek® (No Parts)		525-5395-15P-A5
2	Leg with Leveler Asm. Shrek® Green	4	500-5921-44
Item 2 is secured by: Leg Bolt Back Plate (535-5703-00) and Leg Bolt 3/8" X 16 X 2-1/2" Hex 5/8" Hd. (2/per) (231-5001-01) Leg Leveler ONLY (3/8"-16 X 3") (500-5017-00).			
3S	Start Button (Green Round) with Sw. + Lamp	1	500-6388-44-TL
4T	Tournament Button (Yellow Sq.), w/Sw. + Lmp.	1	500-6587-06-TL
Item 3S & 4T includes the Switch & Lamp (No Wiring; desolder old wiring where required). Switch or Bulb replacement: TWIST LOCK (-TL) >> not snap-in << Assembly Parts Included: Microswitch (180-5174-00); #55 Wedge Base Clear Bulb (165-5002-00); If 4T is not desired, use optional Button Plug Black (500-6566-00). Requires 3-Lug Terminal Strip (055-5204-03) and Diodes, 1N4004 (Qty. 2) (112-5003-00) inside cabinet under button(s) for Lamp Operation (Diode for Switch, located on Switch.)			
5	Flipper Button (Yellow) Assembly (No Switch)	2	500-5026-36
Item 5 is secured by: Pal Nut for Flipper Button (Metal) (Qty. 2/per) (240-5003-01) Pal Nut inside cabinet secured by: #8 X 1/2" SHWH AB (Zinc) (Qty. 1/per) (234-5101-00) and Washer (Zinc), .187" ID X .875" OD X .048" Thick (Qty. 1/per) (242-5059-00)			
6S	Flipper Switch Single Assembly	0	500-6889-01
Assembly Parts Included: Flipper Switch Stack Single (Paliney Contact) (180-5160-01) and Capacitor - Ceramic .05 Mfd 25 volt (130-5001-00)			
Item 6S/6D are secured to Cab. by: #6 X 1-1/4 SHWH AB (Zinc) (Qty. 2/per) (237-5959-00)			
6D	Flipper Switch Double Assembly	2	500-6890-01
Assembly Parts Included: Flipper Switch Stack Double (Paliney Contact) (180-5164-01) and Capacitor - Ceramic .05 Mfd 25 volt (130-5001-00)			
Item 6S/6D are secured to Cab. by: #6 X 1-1/4 SHWH AB (Zinc) (Qty. 2/per) (237-5959-00)			

Nr.	CAB. PARTS & SWITCHES	QTY.	SPI PART Nr.
7	Rear Glass Channel 20-3/8" Length	1	545-5038-00
8	Plastic Channel 42-5/8" Lg. (Left/Rt.)	2	545-5017-00
9L	Side Armor (L.) w/Button Guard (Grn)	1	535-9596-30
9R	Side Armor (Right) w/B.G. (Green)	1	535-9596-31
Items 9L & 9R are secured @ front & side by: Pem Stud 1/4 X 1" Flange Head (Zinc) 93580A195 (Qty. 1/per) (237-6116-00), 1/4-20 Flange Nut (Qty. 1/per) (240-5300-00) and #8 X 5/8" PPH AB (Zinc) (Qty. 5/per) (232-5101-00); @ rear (backbox) by: #10-24 X 1" Sq. Neck Carr. Bolt Zinc (Qty. 1/per) (231-5021-01) and #10-24 Hex Nut (Qty. 1/per) (240-5202-00)			
10	Front Molding (Green) < NO BUTTON HOLE >	1	500-6882-02-03
Item 10 includes: Self-Adhesive Foam Rubber 3/8" X 3/16" X 20-3/8" (3) (626-5001-00) Items 10 works with Item 22 (next page) ONLY.			
11	Playfield Glass (Tempered) 21" X 43" X 3/16"	1	660-5001-00
12	Hex Key Allen Wrench 5/16"	1	777-0001-00
13	Corrugated Tubing Black 1"ø X 2.6" Lg.	1	605-5008-03
Above Item 13 covers the Cable Wiring Harnesses going into the Backbox from the Cabinet.			
14	Roto Lock Male (R2-0055-02)	1	355-5006-01
Item 14 is secured by: #10-24 X 1-3/4" Carriage Bolt Square Neck (Qty. 2) (231-5022-00), #10-24 Nylon Stop Nut (Qty. 2) (240-5206-00) and #10 Washer, 7/32" ID X 1/2" OD X 1/16" Thick (Qty. 2) (242-5003-00)			
15	Roto Lock Female (on Backbox)	1	355-5006-02
16	Ball Shooter (Plunger) Assembly	1	500-6146-00-04
FOR A BREAKDOWN OF PARTS SEE: Sec. 4, Chp. 2, Drawings for ... Assemblies...			



Cabinet - Parts & Switches Continued

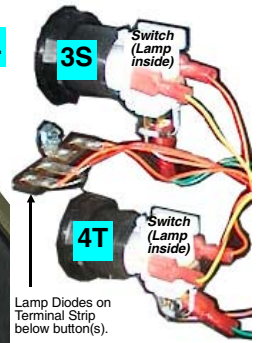
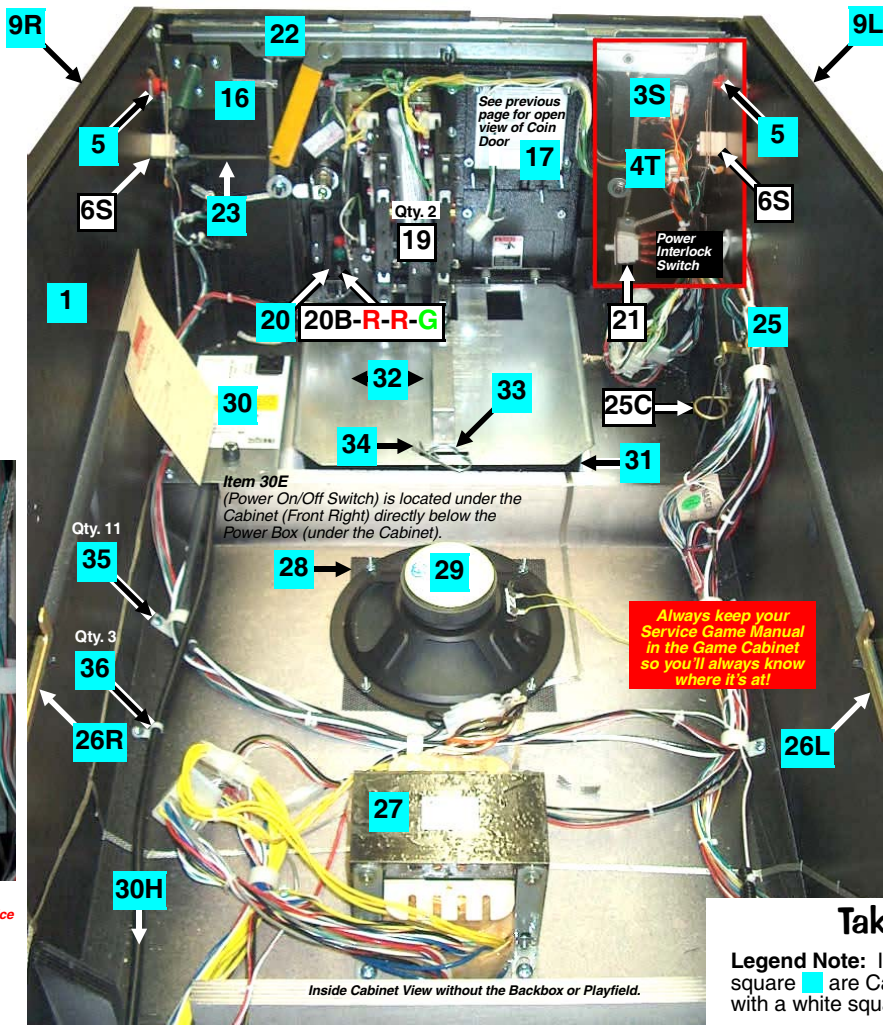
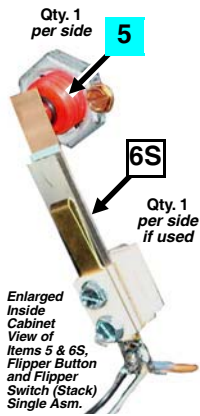

Enlarged Inside Cabinet View of Items 3S, 4T and 25 (25B, 25C, 25H & 25W), Plumb Bob Tilt Switch.

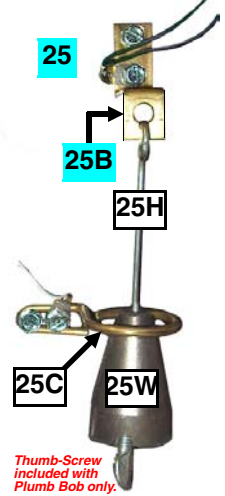

Enlarged Inside Cabinet View of Items 30: Power Box (30A), Service Outlet (30G), Fuse (30K) and Fuse Holder (30L).

Take Note:

Legend Note: Items noted with a cyan square ■ are Cabinet Parts. Items noted with a white square □ are Switches.

Nr.	CAB. PARTS & SWITCHES	QTY.	SPI PART Nr.	Nr.	CAB. PARTS & SWITCHES	QTY.	SPI PART Nr.
◀ PARTS TABLE & VIEWS CONTINUED FROM THE PREVIOUS PAGE.							
17	Coin Door 2-Cht \$V Up-Stk. 4-Button Bracket	1	501-5018-172	27	Transformer 5.7VAC (with Ballast Winding)	1	010-5012-01
Item 17 is secured by: 1/4"-20 X 1-1/4" Carriage Bolt Square Neck (Qty. 4) (231-5003-00) 1/4"-20 Flange Nut (Qty. 4) (240-5300-00) and Fend Washer 1/4" I.D. X 1" O.D. (Qty. 3) (242-5009-00) Note: For Coin Door other than USA call Technical Support for SPI Part Nr.				Item 27 is secured by: 1/4"-20 X 5/8" PPH MS (Zinc) (Qty. 4) (237-5854-00) and 1/4" Split Lock Washer (Qty. 4) (244-5000-00)			
18	Lock 7/8" Barrel, 435X, Offset Cam	1	355-5021-03K	28	Speaker Grill 7" X 7"	1	545-5072-03
Coin Door Switch (USA) (Happ)				29	Speaker 8" ø Round 8010 4Ω	1	031-5007-01
19	ALT. SW.: 19C: Coin Door Switch (USA) (Coin Control) (180-5024-00)	2	180-5024-01	Items 28 & 29 are secured by: #6-32 X 1-1/4" Fin Shank Screw (Qty. 4) (237-5883-00) and #6-32 Keps Nut (Qty. 4) (240-5008-00)			
ALT. SW.: 19J: Coin Door Switch (¥ Japan) (180-5091-00)				Power Input Box Assembly			
20	4-Button Bracket (for Service Menu Buttons)	1	535-6860-04	30A: Power Box (No Parts) Mounting Frame (535-5932-00)			
SWITCH: 20B: Push-Button Service Switch (Black) (180-5192-00)				30B*: Line Filter (150-5000-00)			
SWITCH: 20R: Push-Button Service Switch (Red) (Qty. 2) (180-5192-02)				30C*: Varistor* TNR159211KM (Domestic) (150-5001-00)			
SWITCH: 20G: Push-Button Service Switch (Green) (180-5192-04)				30D*: Varistor TRM15G431KM (Euro) (150-5002-00)			
Ordering Note: Securing hardware for switches included. Decal in kit sold separately.				SWITCH: 30E: On/Off Rocker Switch + Bracket Assembly (515-7085-00)			
21	Power Interlock-Memory Protect Switch Asm.	1	500-5808-05	30E incl.: Switch, APEM R2101C5NBB (180-5001-03) + Bracket (535-8318-00)			
Assembly Parts Included: Mounting Bracket (535-9794-00), Power Interlock (Playfield) Switch (180-5136-00) and secured by: #8 X 1/2" SHWH AB (Zinc) (Qty. 2) (234-5101-00)				30F*: Power Box Decal (820-6123-03)			
22	Front Molding Lockdown Asm.	1	500-6881-00	30G: Service Outlet (3-Prong / US) (180-5008-01)			
Item 22 is secured by: #10-24 X 1-1/4" Carr. Bolt (Qty. 2) (231-5012-00), #10-24 Keps Nut (Qty. 2) (240-5207-00), #8 X 1/2" SHWH AB Zinc (Qty. 1) (234-5101-00) and #10 Washer 7/32" I.D. X 1/2" O.D. X 1/16" (Qty. 1) (242-5003-00)				30H: Line Cord 10' ROJ 3" + Ring Terminal Assembly (515-6566-00)			
23	Lockdown Spring (connected to handle)	1	265-5008-00	30H incl.: Line Cord 10' ROJ 3" (034-5000-10) + Ring Terminal (055-5031-10)			
24	Grills 2-1/2" X 18" (on Back & Bottom)	2	545-5072-02	30I: Recessed (Black) Cup (rear of Cabinet) (545-5122-00)			
Plumb Bob Tilt Switch Individual Parts Only Ind. Parts Only				30J*: Snap Bushing 9/16" (White) (280-5001-01)			
25	SWITCH:	25B: Bracket for Hanger Wire (535-5221-00)					
		25C: Contact Wire Form (535-7563-01)					
		25H: Hanger Wire (535-5319-02)					
		25W: Plumb Bob Weight (535-5029-00) (includes Thumb-Screw)					
Item 25B is secured to Cabinet by: #8 X 1/2" SHWH AB (Zinc) (Qty. 4) (234-5101-00)							
26L	Slide & Pivot Support Bracket (Left)	1	535-5989-00	31	Cash Box Plastic Bottom	1	545-5090-00
26R	Slide & Pivot Support Bracket (Right)	1	535-5990-00	32	Cash Box Cover (Validator)	1	535-5013-03
Items 26L & 26R are secured by: #10-24 X 1-1/4" Carriage Bolt Square Neck Black (3/per) (231-5012-00) and #10-24 KEPS Nut (3/per) (240-5207-00)				33	Cash Box Lock Bracket (U-Wire)	1	535-7562-00
				Item 33 is secured by: #8 X 5/8" HWH AB (Green) (Qty. 2) (234-5102-04)			
25	Zip Cable Tie (Screw Down Style)	3	040-5005-00	34	Large Hair-Pin Clip	1	535-7772-00
Item 36 is secured by: #8 X 7/8" PPH AB (Zinc) (Qty. 1/per) (232-5103-00)				35	Clamps [Multiple Sizes]	11	040-5000-XX
				Item 35 is secured to Item 1 by: #8 X 1/2" SHWH AB (Zinc) (Qty. 1/per) (234-5101-00) For following sizes, replace -XX with: 3/4" Single = -08 (Qty. 8); 1-1/2" Single = -10 (Qty. 3)			
37†	Meter +12VDC with Bracket Optional	0	G-0053-013-102	36	Zip Cable Tie (Screw Down Style)	3	040-5005-00
† Meters (Diode included) are optional and were not included in this Pinball Machine. Order without the bracket use G-0053-013-102A. More information or Qs? Call Technical Support.							

Sec. 4: Parts Id. ...



Main Playfield Top - Miscellaneous Parts and Brackets

Nr.	THE PLAYFIELD	QTY.	SPI PART Nr.
Main	P/F Screened w/ Inserts & NO Parts	1	830-5100-A5
P/F	P/F Complete w/ Inserts & ALL Parts	1	505-6004-A5-A5

Nr.	MISC. PARTS (ABOVE)	QTY.	SPI PART Nr.
1	Arch (Black Metal) [no Forks]	1	535-8392-01
Item 1 is secured to Item 9 below by: #10-32 X 5/16" PFH U/C MS (Zinc) (Qty. 2) (237-6013-00) Usage Note: When replacing the Arch, order new replacement Nelson Protect Strips 7-5/8" (not included) (Qty. 2) (545-5212-04; use -02 for 8-9/16" size) For Decals, see <i>Playfield Top - Plastics Kit, Decals & Mylar Kits.</i>			
2	Instruction Card [Eng./Esp.] Shrek®		755-51A5-12-Y
Note: Visit www.sternpinball.com for a PDF copy of the Game Instruction Card which will also have any translated Instruction Cards made for this game. Find Game Link or Archives.			
3A	Coin Card (2-Sided) USA 10 Default	1	755-5400-11-Y
3B	Coin Card (2-Sided) USA 5	1	755-5400-08-Y
For Coin Card views, see below or online: http://www.sternpinball.com/coinagecards.shtml Ordering Note: If this is a non-US Game, Coin Card(s) Part Numbers provided will differ.			



4	Bumper [Pop] Cap (Multi-Colors)	2	550-5057-XX
Replace -XX in the part number with -04 (Green); -06 (Yellow) Item 4 is secured by: #4 X 3/4" PRH (Zinc) T-25 (Qty. 2/per) (237-5873-00)			
5	Light Cover w/ tabs (Multi-Colors)	5	550-5031-XX
Replace -XX in the part number with -01 (Clear); -06 (Yellow); -11 (Fluor. Green) Item 5 is secured to the Backpanel by: #8 X 1/2" SHWH AB (Zinc) (Qty. 2/per) (234-5101-00) and is secured to the Plastics by: #6-32 X 1/2" PPH Sems (Zinc) (Qty. 2/per) (232-5202-00) and #6-32 Nylon Stop Nut (Qty. 2/per) (240-5005-00)			
6	Light Reflector (Silver)	4/2	545-5409-01
Ordering Note: #555 Wedge Base Bulb (165-5002-00) (Qty. 1/per); Wedge Base Socket (Laydown) (077-5026-01) (Qty. 1/per) (views on Page 64)			
7	Bubble Level Assembly	1	500-6815-00
Assembly Parts Included: Level .8mm Empire #0224 (545-6001-01) or Level Mount (545-6068-00). Flange secured by: #6-32 X 1/4" PPH MS (no Sems) Zinc (237-5500-00) and #6-32 Keps Nut (240-5008-00) Item 7 is secured to the Wood Rail by: #6 X 1/2" HWH AB Zinc Red (Qty. 2) (234-5001-02)			
8	Pinball (Steel) 1-1/16" ø	8	260-5000-00

Nr.	MISC. BRACKETS (ABOVE)	QTY.	SPI PART Nr.
9	Bracket, Playfield Hanger	2	535-8385-00
Item 9 is secured to the Playfield (P/F) by: #8-32 X 7/8" HWH MS Zinc (Qty. 2/per) (237-5890-00) and #8-32 T-Nut (Qty. 2/per) (240-5101-00)			
10	Bracket, Arch Retaining (Hold-Down)	2	535-8394-00
Item 10 is secured to the P/F by: #8 X 1/2" SHWH AB (Zinc) (Qty. 3/per) (234-5101-00)			
11	Bracket, Plate (Newton Ball)	2	535-9523-00
Wire Form (Newton Ball Retention) 2 535-9522-00			
Item 11 is secured by: #8 Washer (Qty. 1/per perm) (242-5005-00), 3/16" I.D. Rubber Ring (Black) (Qty. 4) (545-5348-01) and #8-32 Nylon Stop Nut (Qty. 1/per perm) (240-5102-00)			
12	Bracket, Gate with Spring Flap Asm.	1	515-7436-00
Wire Form (for above Gate Bracket) 1 535-9683-00			
Item 12 is secured by: #8-32 Nylon Stop Nut (Qty. 2) (240-5102-00) Ref. Asm: 500-6853-00			
13	Bracket, Ramp Mounting	1	515-6508-00
Item 13 is secured to the Wood Rail by: #6 X 1/2" PTH A (Zinc) (Qty. 2) 237-5809-00			
14	Bracket, Support (for Fiona)	1	535-0132-00
Item 14 is secured by: #6-32 X 1-1/4" PPH MS (Zinc) (Qty. 1) (237-5508-00), #6-32 X 1-1/2" PPH MS (Zinc) (Qty. 1) (237-5510-00) and @ figurine by: #6-32 X 7/8" PPH MS Ext. Sems (Zinc) (Qty. 2) (232-5205-00) and Spacer 5/8" X 3/8" (Qty. 2) (254-5000-14)			
15	Bracket, Support (for Gingy)	1	535-0124-00
Item 15 is secured by: #6 X 1/2" HWH AB Zinc Red (Qty. 2) (234-5001-02) and @ figurine by: #6-32 X 3/8" PPH Sems (Zinc) (Qty. 1) (232-5201-00) and #6-32 X 7/8" PPH MS Ext. Sems (Zinc) (Qty. 1) (232-5205-00)			
18	Bracket, Support (for Mini-Pinball)	1	535-9975-00
Item 18 is secured to Back Panel by: #8-32 X 5/8" SHWH Serr. Swage (Zinc) Wax (Qty. 2) (237-5975-03) and #8-32 T-Nut (Qty. 2) (240-5101-00) See Page 89.			

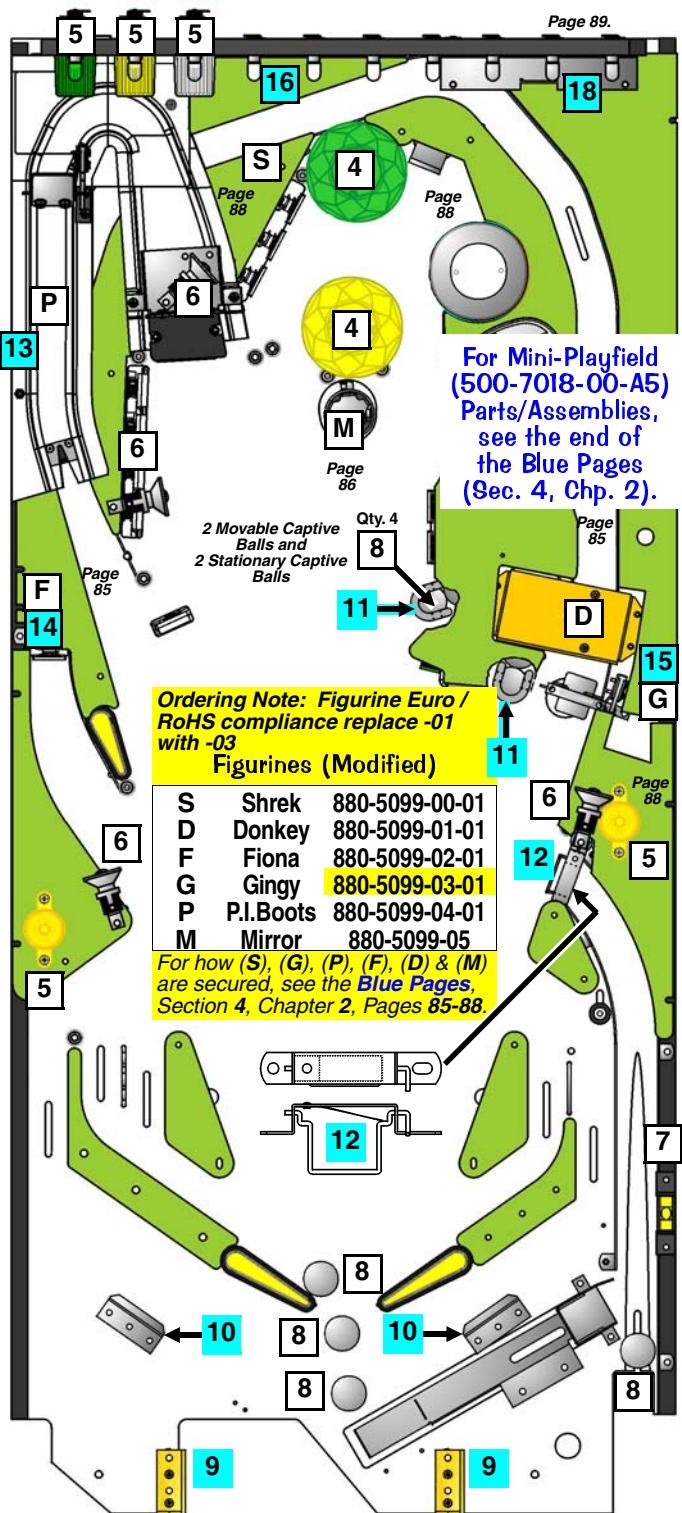

For Mini-Playfield (500-7018-00-A5) Parts/Assemblies, see the end of the Blue Pages (Sec. 4, Chp. 2).

Ordering Note: Figurine Euro / RoHS compliance replace -01 with -03

Figurines (Modified)

S	Shrek	880-5099-00-01
D	Donkey	880-5099-01-01
F	Fiona	880-5099-02-01
G	Gingy	880-5099-03-01
P	P.I.Boots	880-5099-04-01
M	Mirror	880-5099-05

For how (S), (G), (P), (F), (D) & (M) are secured, see the **Blue Pages**, Section 4, Chapter 2, Pages 85-88.

For Mini-Playfield Parts, Assemblies and/or Main Playfield brackets securing other plastics or parts on assemblies not shown on this page, see the **BLUE PAGES**, Pages

Take Note:

Legend Note:
Items noted with a white square are Misc. Parts (Above).
Items noted with a cyan square are Misc. Brackets (Above).

Optional Kits available through your Distributor:

Pinball Location Maintenance Standard Kit: 502-6002-A5

Kit includes: 8 oz. Novus Wax #2 Fine (Red) (675-0003-01), Cloth, Rubber Rings (used above playfield), Bulbs (Bulb quantities vary and is limited to 25 per type), Fuses (5/per type) and 4 Pinballs. **Note:** Quantities, sizes and contents subject to change without notice.

Sec. 4: Parts Id. ...



Main Playfield Bottom - Miscellaneous Parts and Brackets

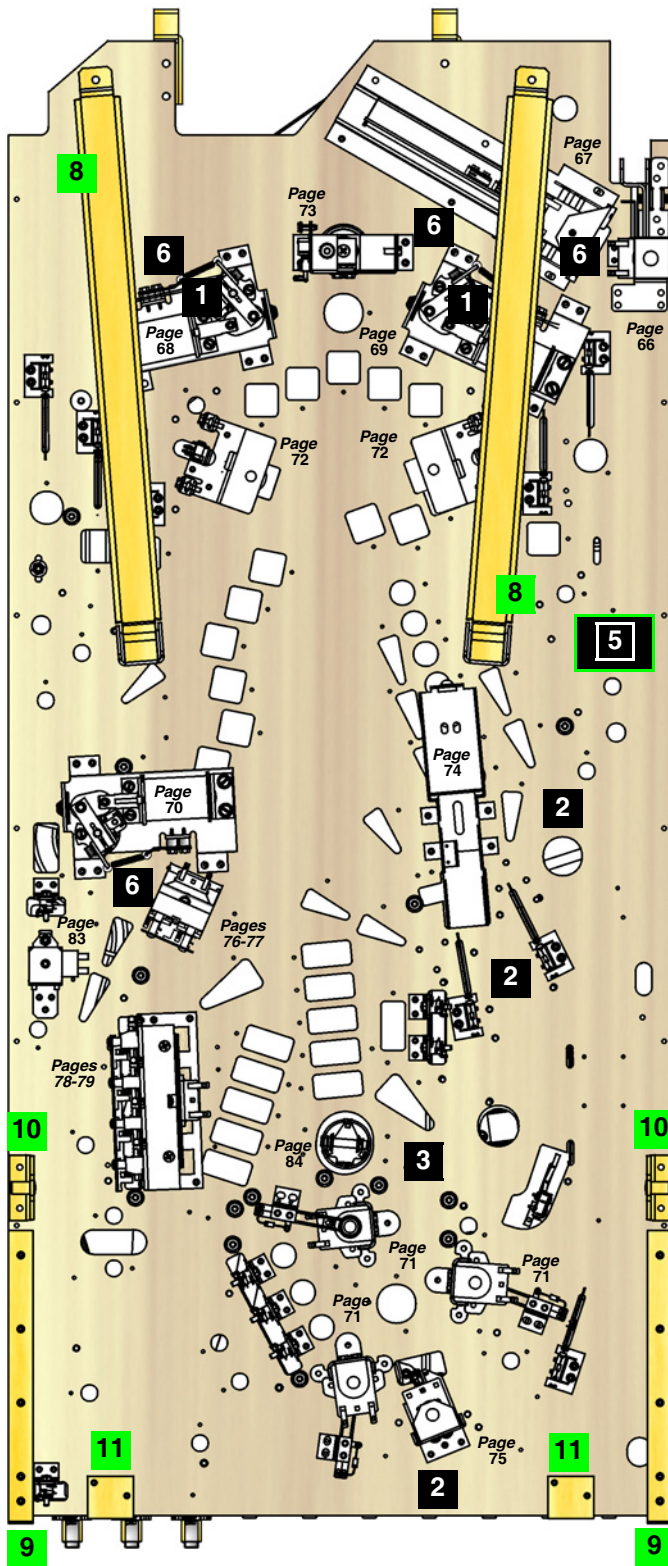

Nr.	THE PLAYFIELD	QTY.	SPI PART Nr.
Main	P/F Screened w/ Inserts & NO Parts	1	830-5100-A5
P/F	P/F Complete w/ Inserts & ALL Parts	1	505-6004-A5-A5

Nr.	MISC. PARTS (BELOW)	QTY.	SPI PART Nr.
1	Insulation Fiche Paper (under Lower Flippers)	2	545-5721-00
2	Diode Terminal Strip 2-Lug (810) Isolated	3	055-5203-00
3	Diode Terminal Strip 3-Lug (813) Isolated	1	055-5204-03
4	Diode Terminal Strip 5-Lug (813) Isolated	0	055-5204-05

Items 2-4 are secured by: #6 X 3/8 HWH AB Zinc (Qty. 1-2/per) (234-5000-00)
 Note: 1N4004 Diodes (112-5003-00) are used in all Diode applications. 1N4001 Diodes can be used for Switches and/or Lamps.

5	PCB, Stepper Motor Controller	1	511-5045-00
---	-------------------------------	---	-------------

Item 5 is secured by: #6 X 3/4" SHWH AB (Zinc) (Qty. 4) (234-5003-00)
 For more details on Item 4, see Sec. 5, Chapter 4, Printed Circuit Boards, Pages 144.

6	3A 250v Slo-Blo Fuse	3	200-5000-08
	Fuse Clip Holder (Socket)	3	205-5000-01

Item 6 is secured by: #6 X 1/2" PPH AB (Qty. 1/per) (237-5805-00)
 Note: Item 6, Fuse Clip Holder (Socket) 205-5000-01 is part of a set of 12 (205-5000-12). You can order them as individuals (...-01) or a set of 12 (...-12).

7*	Terminal Strip/Fuse Decals A-D	1	820-6221-A5
----	--------------------------------	---	-------------

Note: For Decal Descriptions & Locations, see Playfield Terminal Strips, Fuses & Misc. Wiring Descriptions & Locations, Section 5, Chapter 2, Playfield Wiring.

Nr.	MISC. BRACKETS (BELOW)	QTY.	SPI PART Nr.
8	Bracket, Playfield Support Slide	2	535-6862-05

Item 8 is secured by: #10 X 1/2" HWH A (Zinc) (Qty. 2/per) (237-5817-00), #8-32 X 5/8" SHWH Swage (Zinc) Wax (Qty. 1/per) (237-5975-03) and #8-32 T-Nut (Qty. 1/per) (240-5101-00)

9	Bracket, Edge Slide (Extended)	2	535-5988-01
---	--------------------------------	---	-------------

Item 9 is secured by: #4 X 1/2" PFH (Zinc) (Qty. 5/per) (237-5840-00) and #8-32 T-Nut (Qty. 2/per) (240-5101-00)

10	Bracket, Pivot Pin Welded Assembly	2	500-5329-03
----	------------------------------------	---	-------------

Item 10 is secured by: #8-32 X 5/8" SHWH Swage (Zinc) Wax (Qty. 2/per) (237-5975-03)

11	Bracket, Back Panel Mounting	2	535-8964-00
----	------------------------------	---	-------------

Item 11 is secured by: #8 X 1/2" SHWH AB (Zinc) (Qty. 2/per) (234-5101-00) and #8-32 T-Nut (Qty. 2/per) (240-5101-00)

12*	Tie Post (White Nylon)	7	545-5253-01
-----	------------------------	---	-------------

Item 12 is secured by: #6 X 5/8" SHWH AB Green (Qty. 1/per) (234-5002-00)

Take Note:

* An asterisk (*) indicates item(s) are not noted in the pictorials.

Legend Note:

Items noted with a black square ■ are Miscellaneous Parts (Below)
 Items noted with a green square ■ are Misc. Brackets (Below).

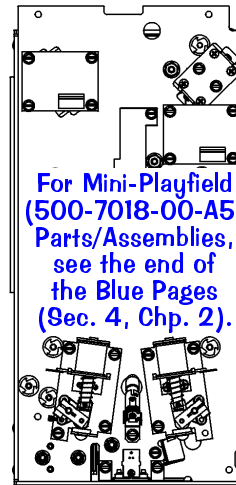

For Mini-Playfield Parts, Assemblies and/or Backpanel Parts not shown on this page, see the BLUE PAGES, Pages 65-94.

Optional Kits available through your Distributor:

Pinball Location Maintenance Deluxe Kit: 502-6003-A5

Deluxe Kit includes: Pinball Location Maintenance Standard Kit as described plus a quantity of Flipper Rebuild Kits. Note: Quantity varies which equals the same quantity of flippers used in this game. ◀ THIS GAME KIT INCLUDES (3) FLIPPER REBUILD KITS ▶

Playfield Top - Switches (Above) (on Gates, Spinners & Stand-Alone)

For Mini-Playfield
(500-7018-00-A5)
Parts/Assemblies,
see the end of
the Blue Pages
(Sec. 4, Chp. 2).

Nr.	SWITCHES	QTY.	SPI PART Nr.
	Exit Gate Assembly	1	Ind. Parts Only
A-33	<i>Individual Parts Only</i> : Switch (180-5087-00), Switch Gate Bracket (535-6303-03), Wire Form on Bracket (535-6304-03), Switch Body Protect Plate (535-6539-00), Diode 1N4004 (112-5003-00) and #2-56 X 1/2" Uns. Serr. HWH #4 Head TR3 Black (Qty. 2) (237-5937-02) (ASM. REF. ONLY 515-6498-05-A5)		
	Switch (for Playfield Wire Gates)	1	180-5087-00

Also see Section 4, Chapter 2, (Blue Pages): Left Ramp Assembly, see T.O.C., Page 65.

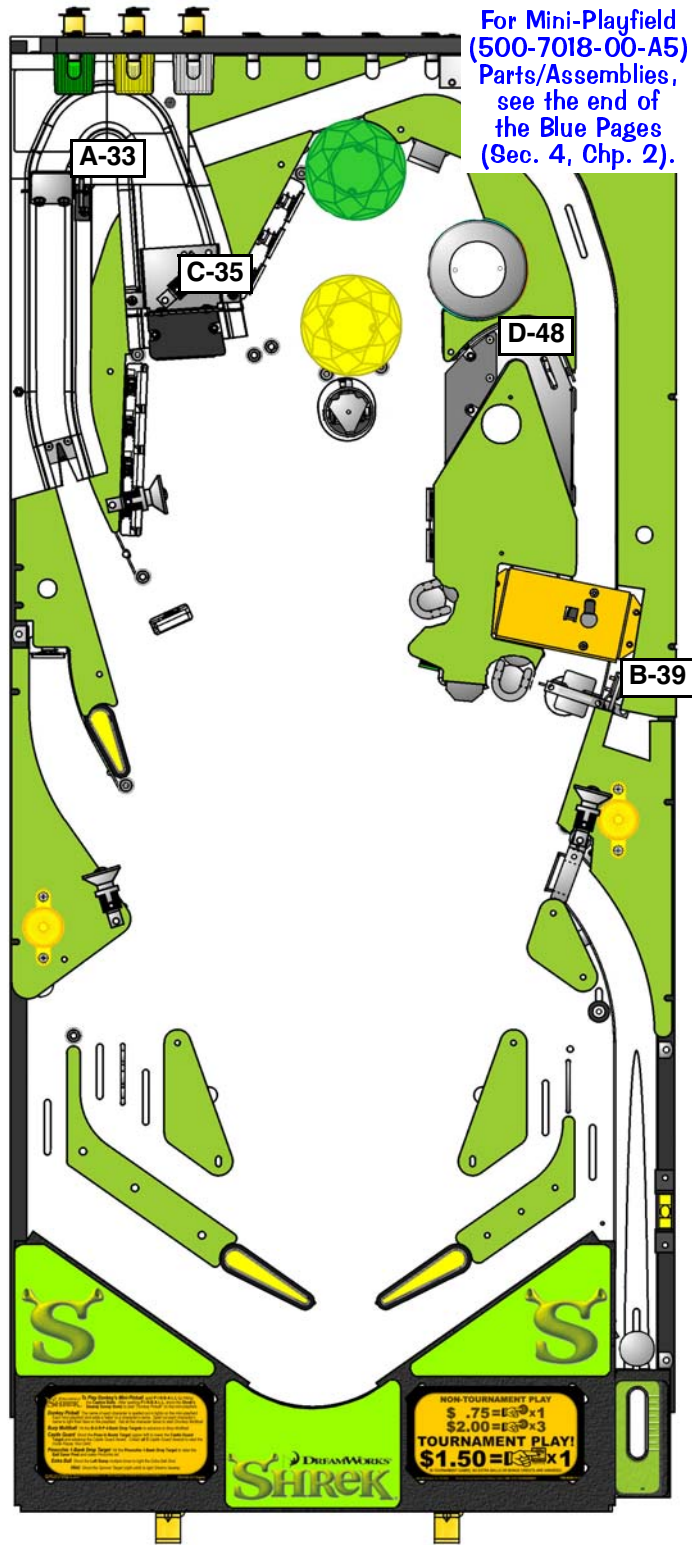
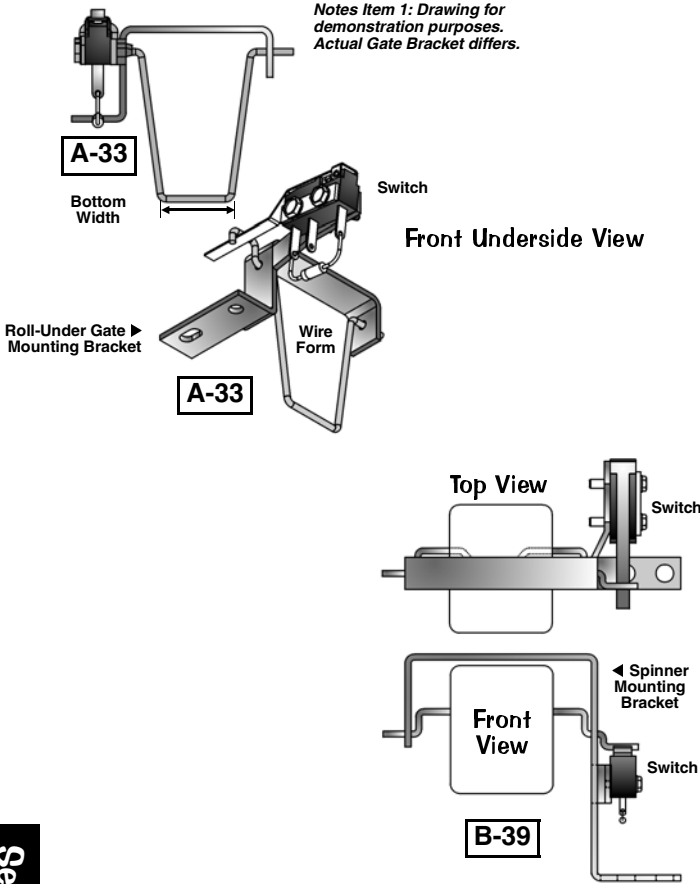

B-39	Spinner & Switch Assembly	1	Ind. Parts Only
	<i>Individual Parts Only</i> : Switch (1-1/4" Actuator Blade) (180-5010-04), Spinner Mounting Bracket (535-8684-01) and Spinner Target Sub-Assembly (515-7088-00) and Lexan Decals (reference only) (Kit: 802-5001-A5) Note: Individual Lexan Decals (830-6394-XX) are not available individually, ordering of kit is required. For all pieces, see Playfield Top - Plastics (Screened & Clear) Kit, Decals* & Mylar* Kits , Page 53. (ASM. REF. 500-6421-01)		
	Switch (1-1/4" Actuator Blade)	1	180-5010-04
C-35	Switch (Roller Actuator, Lite-Force)	1	180-5119-02
	<i>Associated Parts Not Included</i> : Switch Body Protect Plate (535-6539-00) and Diode 1N4004 (Qty. 1/per) (112-5003-00)		
	Item C-6 is secured by: #2-56 X 1/2" Unstl HWH #4 Hex TR3 Blk (Qty. 2/per) (237-5937-02)		
	Also see Section 4, Chapter 2, (Blue Pages): Latch Gate Assembly, see T.O.C., Page 65.		
D-48	Switch (Happ #95-1128-00)	1	180-5183-00
	Requires: Switch Body Protect Plate (535-6539-00), Diode 1N4004 (112-5003-00) and #2-56 X 1/2" Uns. Serr. HWH #4 Head TR3 Black (Qty. 2) (237-5937-02) and #2-56 Hex Nut (Qty. 2) (240-5301-00)		
	Also see Sec. 4, Chp. 2, (Blue Pages): Flat Ramp Asm. (Sneak Lanes), see T.O.C., Page 65.		

example:

"A-#" means, it is Item Number A-# in the Part Table. The "-#" indicates more than 1 switch is present. So it is replaced with the Switch's "Switch Matrix Number" (e.g. A-33, Item A Switch and one of the Switches referenced is from Switch Matrix Number 33).

If only 1 switch type for the item exists, the Switch Number will be listed with the Item Number (e.g. C-39, Item C Switch and the Switch Matrix Number is 39).

Playfield Bottom - Switches (Below) (on Assemblies & Stand-Alone)

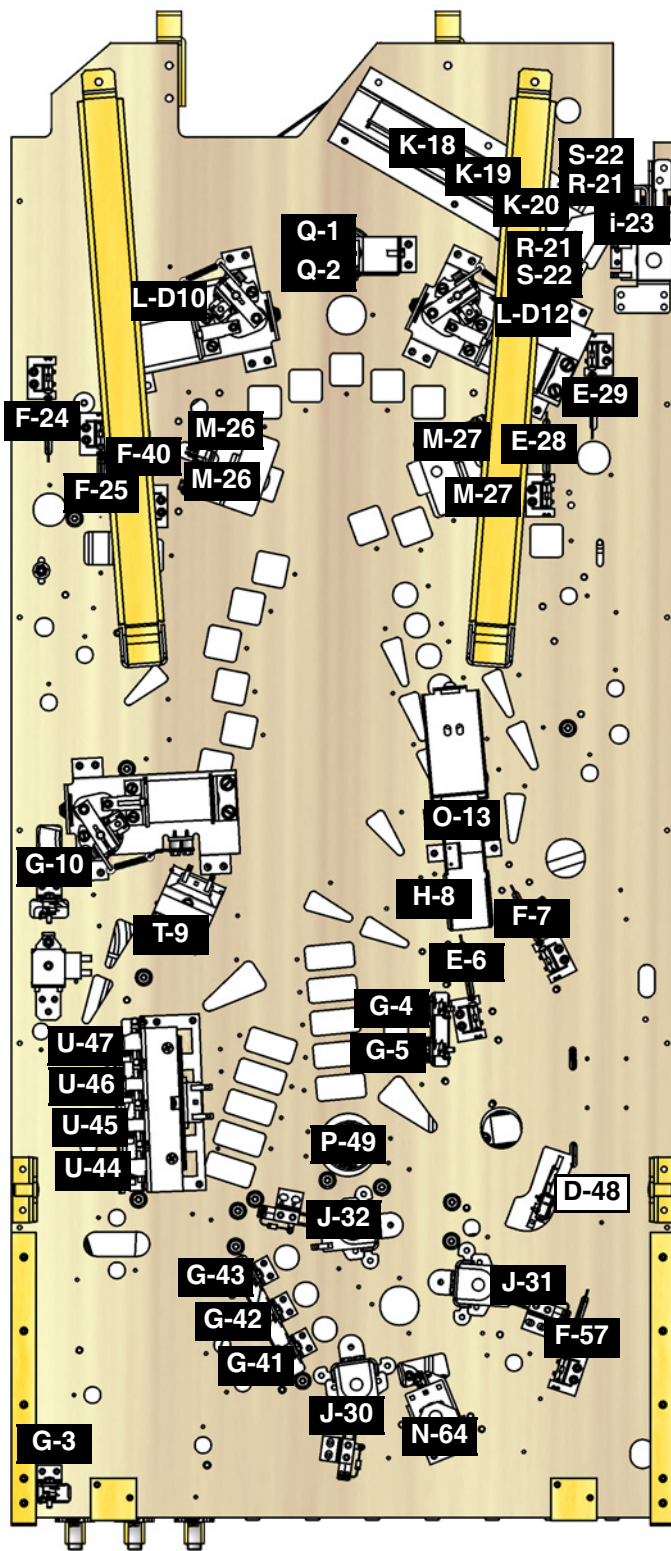

Nr.	SWITCHES	QTY.	SPI PART Nr.
E-#	Sw., Roll-Over Standard Force (Left Mnt. Style) <i>Switch Matrix Numbers 6, 28 & 29.</i>	3	500-6227-01
F-#	Sw., Roll-Over Std. Force (Right Mount Style) Bracket secured to Playfield by: #6 X 1/2" SHWH AB (Zinc) (Qty. 2/per) (234-5001-02) <i>Switch Matrix Numbers 7, 24, 25, 40 & 57.</i>	5	500-6227-02
G-#	Switch & Target Riveted Asm. 1"² (White) Asm. Parts Included: Stack Switch (180-5133-00) and 1" Sq. Target White (545-5470-08) Not Included, order separately: Switch Mounting Bracket (535-6896-00), Switch Back Plate (535-6452-00), Foam Pad (626-5029-00) and #6-32 X 3/4" HWH Swage (Zinc) (Qty. 2) (237-5976-05) <i>Switch Matrix Numbers 3, 4, 5, 10, 41, 42 & 43.</i>	7	515-5162-08
H-8	Switch & Target Riveted Asm. 1/2" (Green) Asm. Parts Included: Stack Sw. (180-5132-00) and 1/2" Narr. Target Green (545-5210-04) Not Included, order separately: Switch Mounting Bracket (535-6896-00), Switch Back Plate (535-6452-00), Foam Pad (626-5029-00) and #6-32 X 3/4" HWH Swage (Zinc) (Qty. 2) (237-5976-05) Note: G-H Plastic Targets are riveted with: Rivet 1/8" ø X 3/16" (Qty. 1/per) (249-5001-00) and Washer 9/64" I.D. X 5/16" O.D. X .048" Thick (Zinc) (Qty. 1/per) (242-5017-00)	1	515-5967-04
i-23	Switch (for Shooter Lane) Associated Part Not Included: Switch Mounting Bracket (535-6173-00) Bracket secured to Playfield by: #6 X 1/2" SHWH AB (Zinc) (Qty. 2) (234-5001-02) <i>Also see Section 4, Chapter 2, (Blue Pages): Shooter Lane Switch Assembly, Page 66.</i>	1	180-5157-00
J-#	Switch Asm., Stack (Blade) (for Pops) Assembly Parts Included: Switch (180-5015-04), Sw. Mounting Bracket (535-7342-00), Spoon Actuator (545-5610-02), Switch Body Protect Plate (535-7344-00), Diode 1N4004 (Qty. 1/per) (112-5003-00) and #6-32 X 3/4" HWH Zc (Qty. 2/per) (237-5976-05) Bracket secured to Playfield by: #8 X 1/2" SHWH AB (Z) (Qty. 2) (234-5101-00) <i>Also see Section 4, Chapter 2, (Blue Pages): Bumper Switch Individual Parts ..., Page 71.</i> <i>Switch Matrix Numbers 30, 31 & 32</i>	3	515-6459-09
K-#	Switch (Roller Actuator, Lite-Force) Associated Parts Not Included: Heat Shrink Tubing 1/8" ø PUI-24 (Qty. 1' per) (605-5006-00) and Diode 1N4004 (Qty. 1/per) (112-5003-00) Item K-# is secured by: #2-56 X 1/2" Unslt HWH #4 Hex TR3 Blk (Qty. 2/per) (237-5937-02) <i>Also see Section 4, Chapter 2, (Blue Pages): 4-Ball Trough Assembly, Page 67.</i> <i>Switch Matrix Numbers 18, 19 & 20</i>	3	180-5119-02
L-#	Switch (End-of-Stroke), Stack (Blade) Item L-# is secured by: #6-32 X 5/8" SHWH Swage (Serr.) Zinc (Qty. 2/per) (237-5976-04) <i>Also see Section 4, Chapter 2, (Blue Pages): ... Flipper Assemblies, Pages 68-69.</i> <i>Dedicated Switch Numbers D10 & D12</i>	2	180-5149-00
M-#	Switch, Stack (Blade) Associated Parts Not Included: Switch Body Protect Plate (Qty. 1/per) (535-5045-00) and Diode 1N4004 (Qty. 1 for every 2 connected together) (112-5003-00) Item M-# is secured by: #6-32 X 5/8" HWH Swage (Ser.) Zinc (Qty. 2/per) (237-5976-04) <i>Also see Section 4, Chapter 2, (Blue Pages): Slingshot Assemblies (Qty. 2/per), Page 72.</i> <i>Switch Matrix Numbers 26 & 27 (Dual Switches = Slingshots)</i>	4	180-5054-00
N-64	Switch (Sim. Roller Actuator) VUKs <i>Also see Section 4, Chapter 2, (Blue Pages): Vertical Up-Kicker Assembly, Page 75.</i>	1	180-5209-00
O-13	Switch (Happ #95-1128-00) <i>Also see Section 4, Chapter 2, (Blue Pages): TV Eject (Scoop) Assembly, Page 74.</i>	1	180-5189-00
P-49	Switch <i>Also see Section 4, Chapter 2, (Blue Pages): Brian Beer Can Assembly, Page 86.</i>	1	180-5189-00
Q-#	Switch (1-1/4" Actuator Blade) <i>Also see Section 4, Chapter 2, (Blue Pages): Up/Down Post Assembly, Page 73.</i> <i>Switch Matrix Number 1 & 2</i>	2	180-5010-04
R-21	Dual OPTO TRANS PC Board Asm. Assembly Parts Included: Dual OPTO Trans. PCB (Qty. 1) (520-5173-00), OPTO PCB Tube Spacer (Brass) (Qty. 3) (530-5308-02) and Rubber Grommet (Qty. 3) (545-5518-00)	1	515-0173-00
S-22	Dual OPTO REC PCB Assembly Assembly Parts Included: Dual OPTO Rec. PCB (Qty. 1) (520-5174-00), OPTO PCB Tube Spacer (Brass) (Qty. 3) (530-5308-02) and Rubber Grommet (Qty. 3) (545-5518-00) Items R-#-S-# are secured by: #6-32 X 5/8" HWH Sw. (Ser.) Zc. (Qty. 3/per) (237-5976-04) <i>Also see Section 4, Chapter 2, (Blue Pages): 4-Ball Trough Assembly, Page 67, or see Section 5, Chapter 4, (Yellow Pages): Trough Up-Kicker Dual OPTO PCBs, Pages 109-111.</i> <i>Switch Matrix Numbers 21 & 22 Switch Note: Both R & S PCBs required per switch.</i>	1	515-0174-00
T-9	PCB, OPTO Interrupter Asm. (1-Bank) <i>Switch Matrix Number 9</i>	1	520-5252-01
U-#	PCB, OPTO Interrupter Asm. (4-Bank) <i>Also see Sec. 4, Chp. 2, (Blue Pages): 1- & 4-Bank Drop Target Asm., see T.O.C., Page 65, or see Section 5, Chapter 4, (Yellow Pages): OPTO Interrupter PCBs, Pages 138-139.</i> <i>Switch Matrix Numbers 44, 45, 46 & 47</i>	1	520-5252-04

example:

"G-#" means, it is Item Number A-# in the Part Table. The "-#" indicates more than 1 switch is present. So it is replaced with the Switch's "Switch Matrix Number" (e.g. G-1, Item G Switch and one of the Switches referenced is from Switch Matrix Number 1).

If only 1 switch type for the item exists, the Switch Number will be listed with the Item Number (e.g. J-23, Item J Switch and the Switch Matrix Number is 23).

For Mini-Playfield (500-7018-00)
Switches & PCBs, see the end of
the Blue Pages (Section 4, Chapter 2).

Sec. 4: Parts Id. ...

P/F Top - Flat Rails & Ramp Asm.
Wood Rails , Ball Guides ,
Wire Forms & Wire Ramp

Nr.	FLAT RAILS	QTY.	SPI PART Nr.
FR1- FR7	Flat Rails #1 - #7 are located on the Mini-Playfield. See Sec. 4, Chp. 2.	1	535-9923-01 - 535-9923-07
FR8	Flat Rail #8 Not Used	0	Not Used
FR9	Flat Rail #9 Not Used	0	Not Used
FR10	Flat Rail #10	1	535-9923-10
Item FR10 is secured by: ■ (Qty. 2) and ⌘ (Qty. 2)			
FR11	Flat Rail #11	1	535-9923-11
FR12	Flat Rail #12	1	535-9923-12
Item FR11 & FR12 are secured by: ■ (Qty. 2/per)			
FR13	Flat Rail #13	1	535-9923-13
Item FR13 is secured by: ■ (Qty. 5), ◆ (Qty. 1) and ❖ (Qty. 1)			
FR14	Flat Rail #14	1	535-9923-14
Item FR14 is secured by: ■ (Qty. 1), ◆ (Qty. 1) and ❖ (Qty. 1)			
FR15	Flat Rail #15	1	535-9923-15
Item FR15 is secured by: ■ (Qty. 3), ◆ (Qty. 2) and ❖ (Qty. 2)			
FR16	Flat Rail #16	1	535-9923-16
Item FR16 is secured by: ◆ (Qty. 2) and ❖ (Qty. 2)			
FR17	Flat Rail #17	1	535-9923-17
Item FR17 is secured by: ■ (Qty. 3) and ⌘ (Qty. 1)			
FR18	Flat Rail #18	1	535-9923-18
Item FR17 is secured by: ⌘ (Qty. 1), ◆ (Qty. 1) and ❖ (Qty. 1)			
FR19	Flat Rail #19	1	535-9923-19
Item FR19 is secured by: ◆ (Qty. 2) and ❖ (Qty. 2)			
FR20	Flat Rail #20	1	535-9923-20
Item FR19 & FR20 are secured by: ◆ (Qty. 2/per) and ❖ (Qty. 2/per)			
FR21	Flat Rail #21 Assembly	1	515-7607-21
Item FR15 is secured by: ■ (Qty. 1), ◆ (Qty. 5) and ❖ (Qty. 5) Ref. Only: 535-9923-21A & 535-9923-21B			
FR22	Flat Rail (Bottom Arch Drain)	1	535-8393-00
Item FR22 is secured by: ■ (Qty. 4)			
FR23	Flat Ramp & Flap Assembly	1	510-5006-00
Items FR23 is secured by: #4 X 5/8" PFH (Black) (Qty. 2) (237-5833-00)			

Nr.	WOOD RAILS	QTY.	SPI PART Nr.
WR1	Wood Rail, 42"	2	525-5007-59
Items WR1 is secured by: #6 X 1-1/4" PFH A (Zinc) (Qty. 12) (237-5804-00)			

Nr.	BALL GUIDES	QTY.	SPI PART Nr.
BG1	Ball Guide, Return Left (Bracket)	1	535-9905-00
BG2	Ball Guide, Return Right (Bracket)	1	535-9906-00
BG3	Ball Guide, 3.0" X 0.12" ø	1	535-5356-04
BG4	Ball Guide, 1.5" X 0.12" ø	1	535-5356-20
BG5	Ball Guide, Outlane Fence Left	1	535-9979-00

Nr.	WIRE FORMS	QTY.	SPI PART Nr.
WF1	Wire Form (Newton Ball Retention)	2	535-9522-00
WF2	Wire Form (on Gate Bracket)	1	535-5307-02
For Wire Forms on Roll-Under Switch Gates or 1-Way Gates, see Previous Page 50.			

Nr.	WIRE RAMP (YELLOW)	QTY.	SPI PART Nr.
WR1	Yel. Wire Ramp (Exit into Left Return)	1	535-9920-01
For a 3D view, see Sec. 4, Chp. 2, Drawings ... Assemblies & Ramps (Blue Pages), Pg. 85.			

Take Note:

Legend Note:

- Items noted with a white square are Flat Rails & Ramp Asm.
- Items noted with a magenta square are Wood Rails.
- Items noted with a red square are Ball Guides (Snubber Wires)
- Items noted with a cyan square are Wire Forms & Wire Ramp.

- #8 X 1/2" SHWH AB (Zinc) (234-5101-00)
- ❖ #8-32 Nylon Stop Nut (240-5102-00)
- ◆ #8 Washer (242-5005-00)
- ⊠ #6-32 X 7/8" Fin Shank Screw (237-5921-04)
- ⌘ #6-32 X 1/2" PTH A (Zinc) (237-5809-00) into Wood Rail.

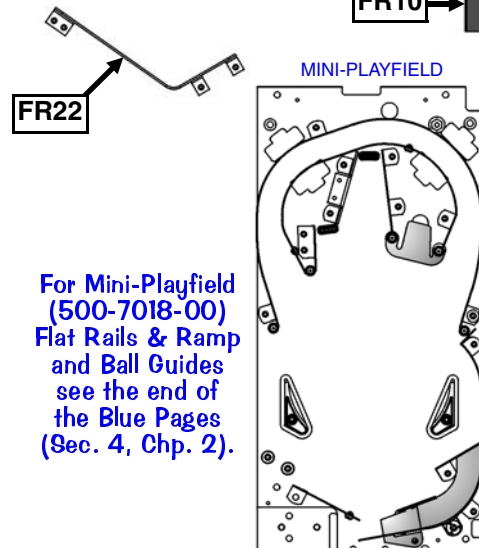
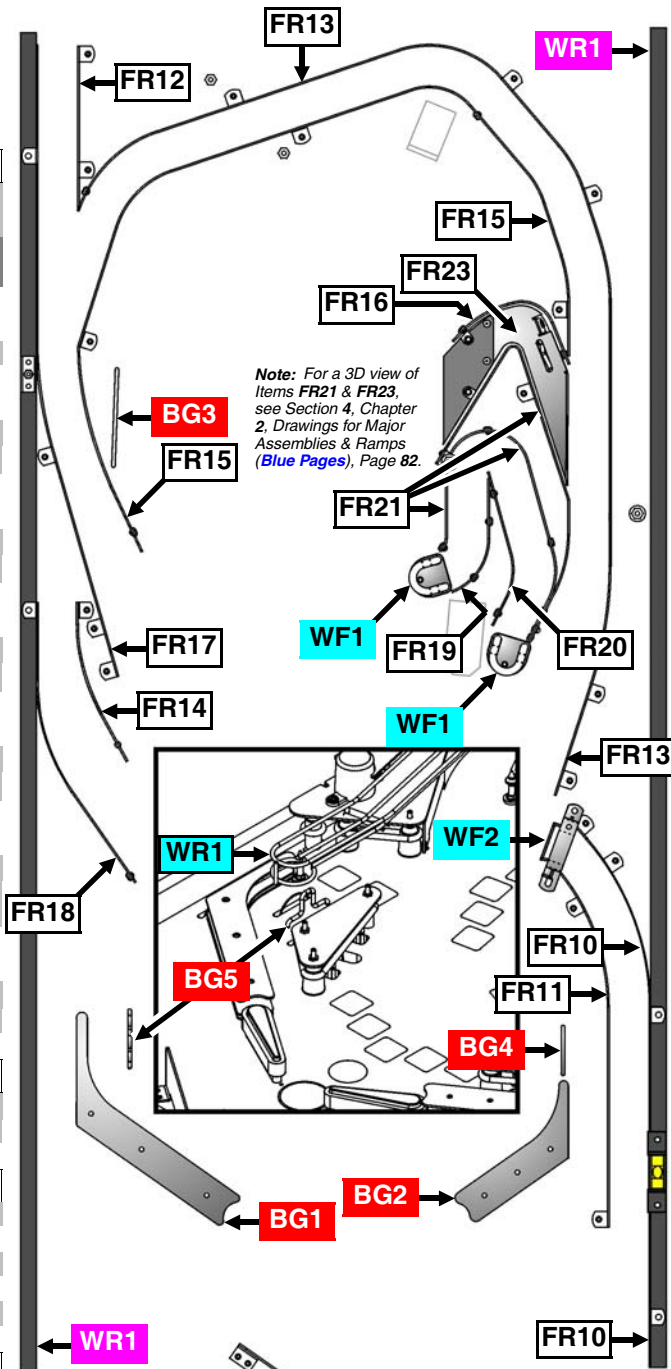

For Mini-Playfield (500-7018-00) Flat Rails & Ramp and Ball Guides see the end of the Blue Pages (Sec. 4, Chp. 2).

Sec. 4: Parts Id. ...



Playfield Top - Plastics (Screened & Clear) Kit, Decals* & Mylar* Kits ‡

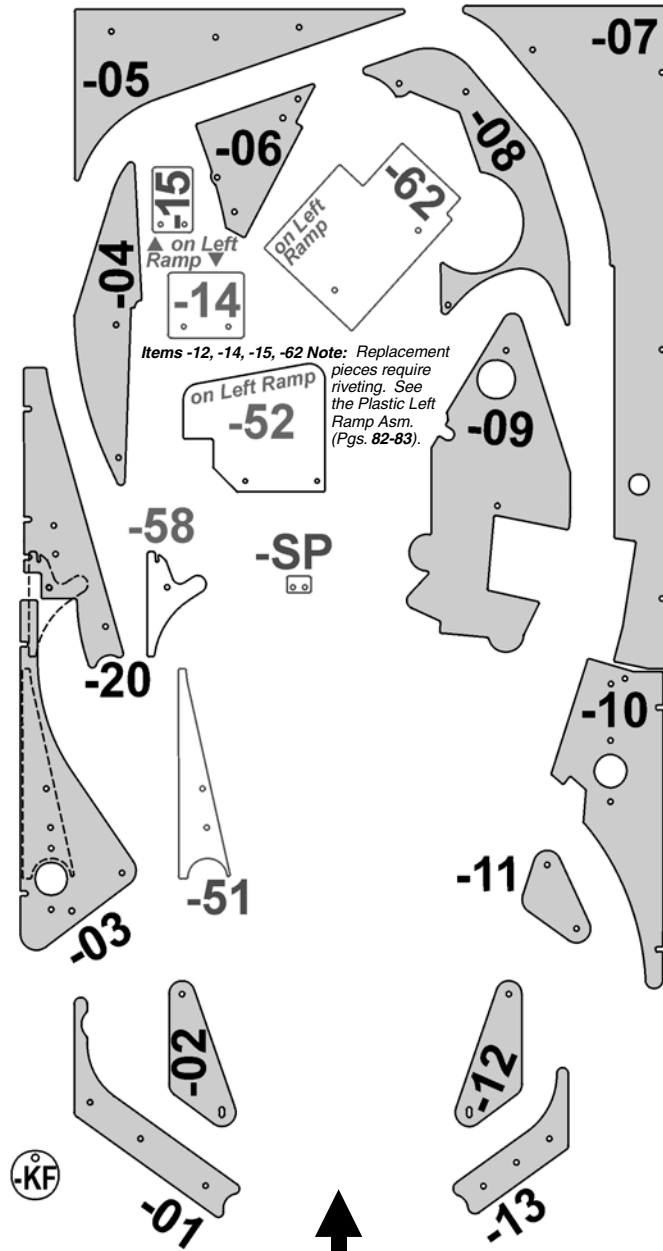

Items -12, -14, -15, -62 Note: Replacement pieces require riveting. See the Plastic Left Ramp Asm. (Pgs. 82-83).

803-5000-A5 Kit (Plastics) includes:
Screened & Clear Sets (830-6074-XX, 830-6075-XX* and 830-6063-00).

* **Ordering Note:** Item 830-6075-63 clear plastic is not included in Kit 803-5000-A5. IT IS INCLUDED with Kit 803-5001-A5.

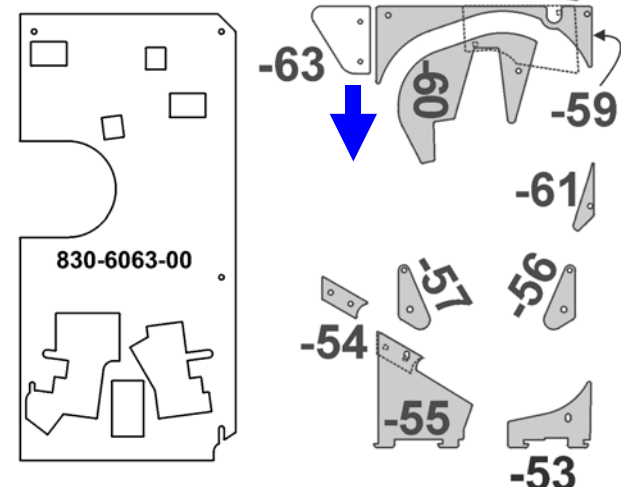

803-5001-A5 Kit (Plastics) includes:
Enclosure Set (830-6084-XX & 830-6075-63)
(requires riveting and reuse of the existing brackets; Also note that Decal 820-6394-29, Inside Front Plastic -91 Protector, is not included. The purchase the Playfield Decal Kit 802-5000-A5 is required).
To order preassembled, use part number 510-5011-00-A5 in lieu of kit.

For details on the Mini-Playfield (500-7018-00-A5) Enclosure Assembly, see the end of the Blue Pages

Sec. 4: Parts Id. ...

‡ **Attention:** No individual Plastic or Decal can be ordered separately, unless noted otherwise. Plastics & Decals are subject to change without notice during and / or after production. Shapes and / or Screening may change. Pieces can be added or subtracted. Service Bulletin(s) will announce any critical changes, if warranted.

Note:

Note that there are two (2) Decal Kits. 802-5000-A5 contains all of the playfield decals **plus** an **extra set** of -22, -23, -24, -25 and -26 for the 1-Bank & 4-Bank Drop Targets.

802-5000-A5 Main Kit (Decals*) includes:
Decal Sets (820-6412-XX, 820-6403-00 (-SMF), and 820-6403-01 (-SMT))

802-5001-A5 D/T Kit (Decals*) includes:
Individual Decals (820-6412-22, -23, -24, -25 & -26)
Only 2 each of the 1-Bank & 4-Bank Drop Targets.

Plastics & Decals Note: Key Fobs subject to availability and may or may not be included in the plastic set. All designs, shapes and pieces used subject to change without notice. Kit contents subject to change.
* Decals/Mylar Not Shown

802-5002-A5 Kit (Mylar*) includes:
Full Playfield Mylar (820-5999-A5) **Not Shown**



Playfield Top & Bottom - Metal Posts & Fin Shank Screws (Actual Size) †

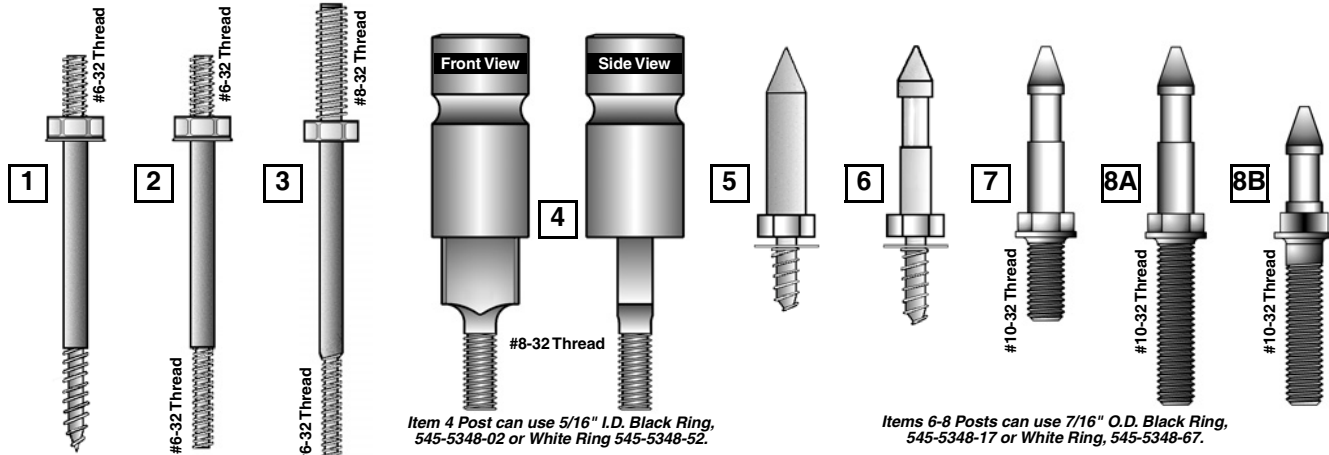

Item 4 Post can use 5/16" I.D. Black Ring, 545-5348-02 or White Ring 545-5348-52.

Items 6-8 Posts can use 7/16" O.D. Black Ring, 545-5348-17 or White Ring, 545-5348-67.

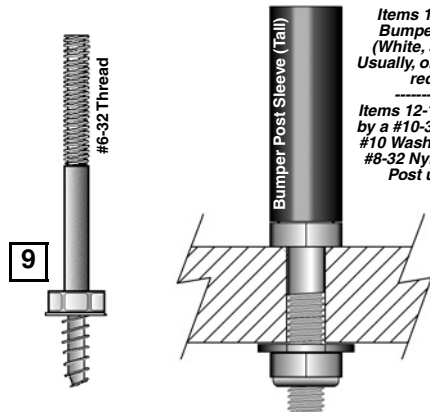

Items 11-16 & 18 Posts can use a Black Bumper Post Sleeve (Tall), 545-5308-00 (White, 545-5308-08 or Red, 545-5308-22) Usually, only Posts which are in the ball path require a Bumper Post Sleeve.

Items 12-15 & 18 Posts are typically secured by a #10-32 Nylon Stop Nut, 240-5203-00 and #10 Washer, 242-5003-00 (Item 11 Post use a #8-32 Nylon Stop Nut, 240-5102-00; Item 16 Post use a #8-32 T-Nut, 240-5101-00).

Take Note:

Legend Note:
Items noted with a white square are Metal Posts. Items noted with a black square are Fin Shank Screws.

A & B Items A & B Note: Typically used to secure Hex Spacers onto the Playfield Wood or Back Panel.

C Item C Note: Quantity 4 on bottom Cabinet Speaker Grill (Qty. 4) (also requires #6-32 Nylon Stop Nut, 240-5005-00).

D Item D Note: Quantity 3/per on the Coil Bracket Welded Assembly (515-5939-00) in the Bumper Bottom Assembly (515-6459-04).

A - D Items A-D Note: The "Fins" keep the screw from turning inside the wood hole.

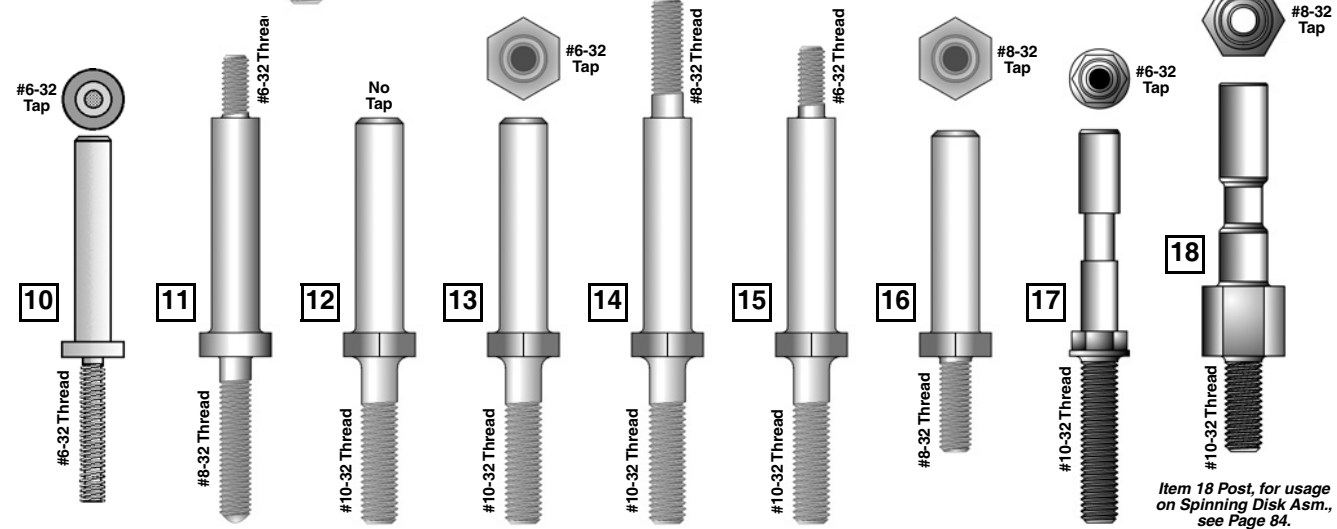

Item 18 Post, for usage on Spinning Disk Asm., see Page 84.

Sec. 4: Parts Id. ...

Nr.	METAL POSTS	QTY.	SPI PART Nr.	Nr.	METAL POSTS	QTY.	SPI PART Nr.	
1	Post [Fasten] #6-32 Thread // Wood Scr.	6/4	530-5010-02	12	Post [Hex Base] NO TAP // #10-32 Thread		530-5332-00	
2	Post [Fasten] #6-32 Thread // #6-32 Thread	13	530-5012-02	13	Post [Hex Bs.] #6-32 TAP // #10-32 Thread		530-5332-01	
3	Post [Fasten] #8-32 Thread // #6-32 Thread	1	530-5008-00	14	Post [Hex Bs.] #8-32 Thread // #10-32 Thread		530-5332-02	
4	Post Brass [Adjustable, Sliding] #8-32 Thread	1	530-5621-00	15	Post [Hex Bs.] #6-32 Thread // #10-32 Thread		530-5332-03	
5	Mini-Post Wood Screw (no cut-away)	2	530-5004-01	16	Post [Hex Bs.] #8-32 TAP // #8-32 Thread		530-5332-04	
6	Mini-Post Wood Screw		530-5004-00	17	Post [Hex Bs.+Groove] #6-32 TAP // #10-32 Thr.	1	530-5679-00	
7	Mini-Post MS // #10-32 .4" Thread		530-5005-01	18	Post [Hex Bs.+Groove] #8-32 TAP // #10-32 Thr.		530-5753-00	
8A	Mini-Post MS // #10-32 .875" Thread	14	530-5005-00					
8B	Mini-Post Short MS // #10-32 .875" Thread	0/5	530-5749-00	Nr.	FIN SHANK SCREWS		QTY.	SPI PART Nr.
9	Post [Fasten] #6-32 Thread // Wood Screw		530-5263-01	A	#6-32 X 3/4" Fin Shank Screw		237-5921-02	
10	Post #6-32 Tap // #6-32 Thread		530-5127-00	B	#6-32 X 7/8" Fin Shank Screw	1	237-5921-04	
11	Post [Fasten] #6-32 Thread // #8-32 Thread		530-5007-00	C	#6-32 X 1 1/4" Fin Shank Screw	(4)	237-5883-00	
				D	#6-32 X 1 3/16" Spiral Fin Shank Screw	8	237-5957-00	

Note: # / X X = Mini-Pinball Qty. See Pages 90-94.



† The item type (size / description), the quantity and/or location used, are subject to change without notice. Service Bulletins will announce any changes, if warranted.

Playfield Top & Bottom - Metal Posts
 □ & Fin Shank Screws ■ Continued

For Mini-Playfield (500-7018-00)
 Metal Posts, see the end of
 the Blue Pages (Sec. 4, Chp. 2).

† The item type (size / description), the quantity and/or location used, are subject to change without notice. Service Bulletins will announce any changes, if warranted.

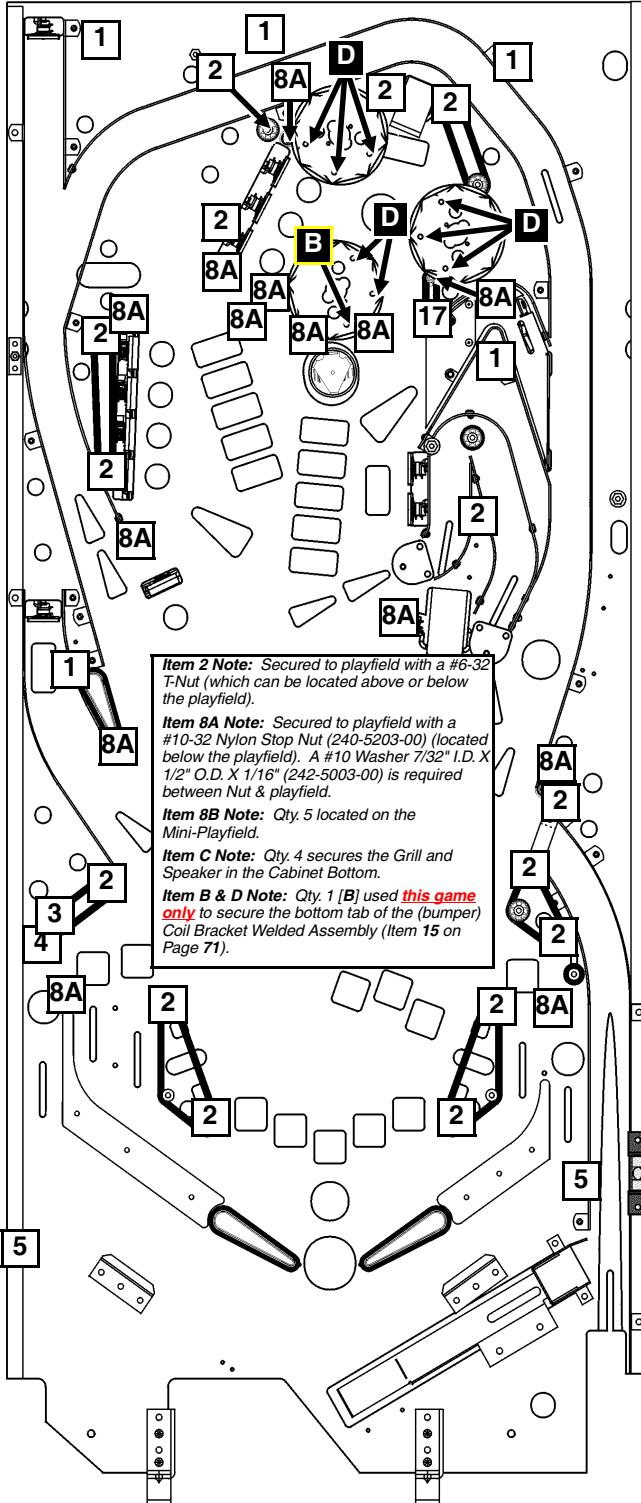

Item 2 Note: Secured to playfield with a #6-32 T-Nut (which can be located above or below the playfield).

Item 8A Note: Secured to playfield with a #10-32 Nylon Stop Nut (240-5203-00) (located below the playfield). A #10 Washer 7/32" I.D. X 1/2" O.D. X 1/16" (242-5003-00) is required between Nut & playfield.

Item 8B Note: Qty. 5 located on the Mini-Playfield.

Item C Note: Qty. 4 secures the Grill and Speaker in the Cabinet Bottom.

Item B & D Note: Qty. 1 [B] used **this game only** to secure the bottom tab of the (bumper) Coil Bracket Welded Assembly (Item 15 on Page 71).

Take Note:

Legend Note:
 Items noted with a white square □ are Metal Posts.
 Items noted with a black square ■ are Fin Shank Screws.

Playfield Top & Bottom -
 Nylon Stop, KEPS, Hex, T-, Flange,
 Pal & Wing Nuts* (Actual Size) †

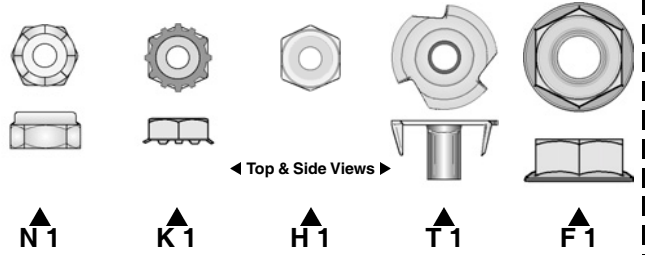

Nr.	NYLON STOP NUTS*	QTY.	SPI PART Nr.
N1	#6-32 Nylon Stop Nut	59/4	240-5005-00
N2	#6-32 N.S. Nut (with 1/4" Hex Body)		240-5010-00
N3	#8-32 Nylon Stop Nut	32/5	240-5102-00
N4	#10-32 Nylon Stop Nut	19/5	240-5203-00
N5	#10-24 Nylon Stop Nut	2	240-5206-00
<small>Item N5 used with #10-24 X 1-3/4" Carriage Bolt Square Neck Black (231-5022-00) located in the Cabinet for the Roto Lock (Male) (355-5006-01).</small>			
N6	#4-40 Nylon Stop Nut		240-5303-00
N7	#4-40 (18/8 Stainless) Nylon Stop Nut		240-5303-01
N8	5/16"-18 Nylon Stop Nut		240-5316-00

Nr.	KEPS NUTS*	QTY.	SPI PART Nr.
K1	#6-32 Keps Nut (with Star Washer)	7	240-5008-00
K2	#6-32 Keps Nut (with 1/4" Hex Body)		240-5011-00
K3	#8-32 Keps Nut		240-5104-00
K4	#10-32 Keps Nut	1	240-5208-00
K5	#10-24 Keps Nut	14	240-5207-00
K6	#4-40 Keps Nut		240-5318-00

Nr.	HEX NUTS*	QTY.	SPI PART Nr.
H1	#6-32 Hex Nut (No Star Washer)	4	240-5004-00
H2	#8-32 Hex Nut		240-5103-00
H3	#10-32 Hex Nut		240-5201-00
H4	#10-24 Hex Nut	2	240-5202-00
<small>Item H4 used with #10-24 X 1" Carriage Bolt Square Neck Black (231-5021-00) located in the Cabinet for the Side Armor Rear (towards Backbox).</small>			
H5	#10-32 X 3/8" Hex Nut		240-5209-00
H6	3/4"-16 Hex Nut		240-5315-00
H7	#2-56 Hex Nut	6	240-5301-00
H8	7/8"-14 Hex Nut		240-5317-00

Nr.	T-NUTS*	QTY.	SPI PART Nr.
T1	#6-32 T-Nut	26/2	240-5002-00
T2	#6-32 T-Nut (with Side Cut Off)		240-5002-01
T3	#8-32 T-Nut	13	240-5101-00
T4	#10-32 (Black Oxide) T-Nut		240-5007-00
T5	#10-32 T-Nut (with Side Cut Off)		240-5205-00
T6	#10-32 X 5/16" T-Nut		240-5204-00
T7	#10-24 T-Nut		240-5200-00

Nr.	FLANGE NUT*	QTY.	SPI PART Nr.
F1	1/4" X 20 Flange Nut	10	240-5300-00
<small>Item F1 used with 1/4"-20 X 1-1/4 Sq. Neck Carriage Bolt Black (231-5003-00) located in the Cabinet for the Side Armor (Front) and Pivot Hinges.</small>			

Nr.	PAL NUTS*	QTY.	SPI PART Nr.
P1	Plastic Pal Nut (on Flipper Buttons)		240-5003-00
P2	Metal Pal Nut (on Flipper Buttons)	2	240-5003-01

Nr.	WING NUTS*	QTY.	SPI PART Nr.
W1	#6-32 Wing Nut		240-5001-00
W2	#8-32 Wing Nut		240-5100-00
W3	#10-24 Wing Nut		240-5211-00
W4	1/4"-20 Wing Nut		240-5302-00
W5	1/4"-20 Toggle Wing		240-5324-00

* **Not Shown:** Items N2-N8, K2-K6, H2-H8, T2-T7, P1-P2 & W1-W5

Sec. 4: Parts Id. ...

Playfield Top - Hex Spacers (Actual Size) †

Hex Spacers:
#6-32
Tap

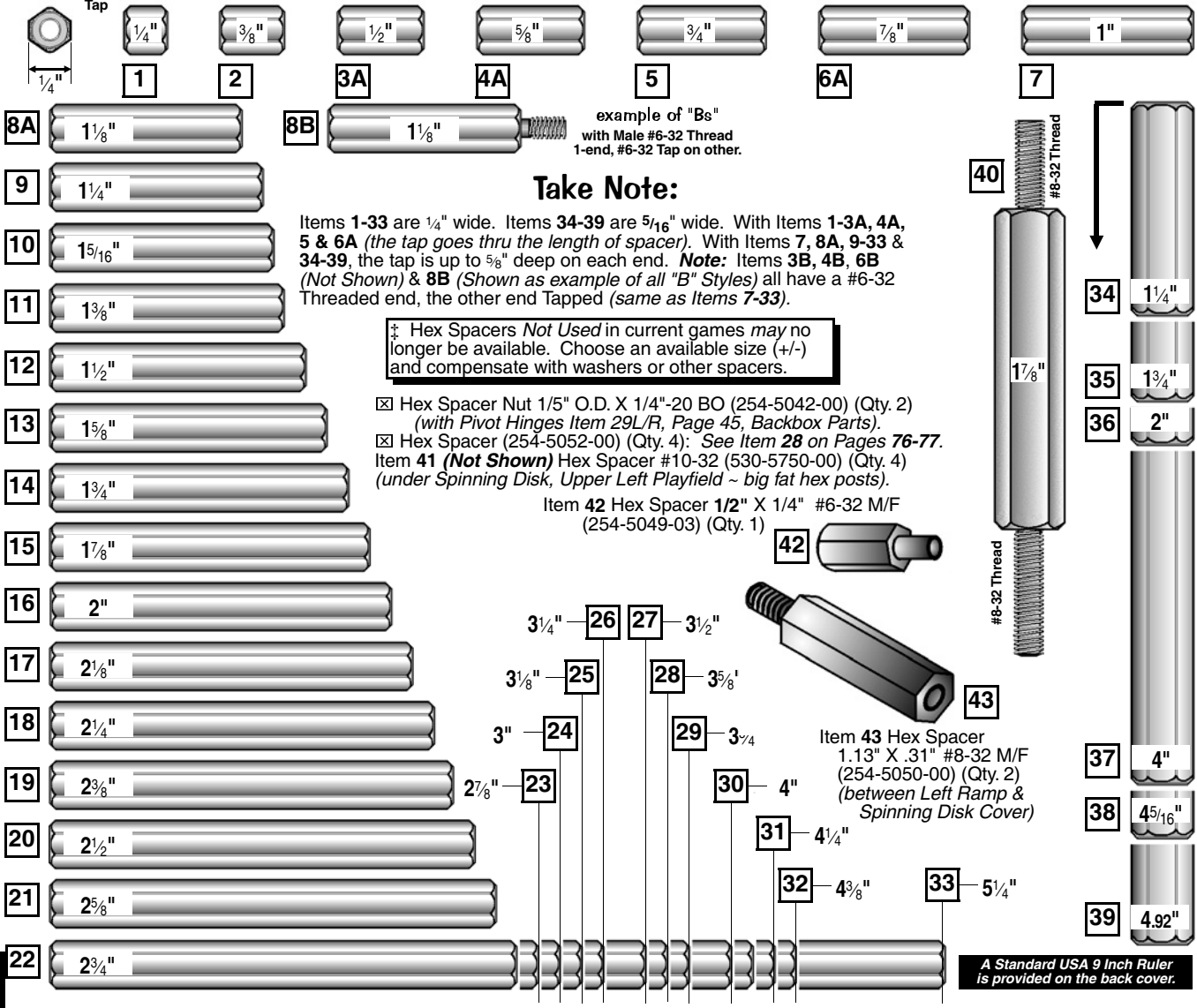

Sec. 4: Parts Id. ...

Nr.	HEX SPACERS	QTY.	SPI PART Nr.	Nr.	HEX SPACERS	QTY.	SPI PART Nr.
1	1/4" X 1/4" : #6-32 Tap (both ends)		254-5008-00	19	2 3/8" X 1/4" : #6-32 Tap (both ends)		254-5008-28
2	3/8" X 1/4" : #6-32 Tap (both ends)		254-5008-12	20	2 1/2" X 1/4" : #6-32 Tap (both ends)		254-5008-16
3A	1/2" X 1/4" : #6-32 Tap (both ends)	4	254-5008-03	21	2 5/8" X 1/4" : #6-32 Tap (both ends)		254-5008-08
3B*	Identical to 3A with #6-32 Thread end		254-5024-03	22	2 3/4" X 1/4" : #6-32 Tap (both ends)		254-5008-15
4A	5/8" X 1/4" : #6-32 Tap (both ends)		254-5008-02	23	2 7/8" X 1/4" : #6-32 Tap (both ends)		254-5008-31
4B*	Identical to 4A with #6-32 Thread end		254-5024-02	24	3" X 1/4" : #6-32 Tap (both ends)		254-5008-14
5	3/4" X 1/4" : #6-32 Tap (both ends)	2	254-5008-04	25	3 1/8" X 1/4" : #6-32 Tap (both ends)		254-5008-19
6A	7/8" X 1/4" : #6-32 Tap (both ends)		254-5008-05	26	3 1/4" X 1/4" : #6-32 Tap (both ends)		254-5008-26
6B*	Identical to 6A with #6-32 Thread end		254-5024-05	27	3 1/2" X 1/4" : #6-32 Tap (both ends)		254-5008-27
7	1" X 1/4" : #6-32 Tap (both ends)		254-5008-06	28	3 5/8" X 1/4" : #6-32 Tap (both ends)		254-5008-25
8A	1 1/8" X 1/4" : #6-32 Tap (both ends)	1	254-5008-17	29	3 3/4" X 1/4" : #6-32 Tap (both ends)		254-5008-36
8B	Identical to 8A with #6-32 Thread end		254-5024-17	30	4" X 1/4" : #6-32 Tap (both ends)		254-5008-21
9	1 1/4" X 1/4" : #6-32 Tap (both ends)		254-5008-11	31	4 1/4" X 1/4" : #6-32 Tap (both ends)		254-5008-30
10	1 5/16" X 1/4" : #6-32 Tap (both ends)		254-5008-34	32	4 3/8" X 1/4" : #6-32 Tap (both ends)		254-5008-29
11 ‡	1 3/8" X 1/4" : #6-32 Tap (both ends)		254-5008-33	33	5 1/4" X 1/4" : #6-32 Tap (both ends)		254-5008-35
12 ‡	1 1/2" X 1/4" : #6-32 Tap (both ends)		254-5008-09	34	1 1/4" X 5/16" : #6-32 Tap (both ends)		254-5018-09
13 ‡	1 5/8" X 1/4" : #6-32 Tap (both ends)		254-5008-13	35	1 3/4" X 5/16" : #6-32 Tap (both ends)		254-5018-06
14 ‡	1 3/4" X 1/4" : #6-32 Tap (both ends)	1	254-5008-10	36	2" X 5/16" : #6-32 Tap (both ends)		254-5018-07
15 ‡	1 7/8" X 1/4" : #6-32 Tap (both ends)	1	254-5008-20	37	4" X 5/16" : #6-32 Tap (both ends)		254-5018-03
16	2" X 1/4" : #6-32 Tap (both ends)		254-5008-07	38	4 5/16" X 5/16" : #6-32 Tap (both ends)		254-5018-00
17	2 1/8" X 1/4" : #6-32 Tap (both ends)		254-5008-32	39	4.92" X 5/16" : #6-32 Tap (both ends)		254-5018-04
18	2 1/4" X 1/4" : #6-32 Tap (both ends)	1	254-5008-18	40	1 7/8" X 3/8" : #8-32 Thread (both ends)		530-5285-00

† The item type (size / description), the quantity and/or location used, are subject to change without notice. Service Bulletins will announce any changes, if warranted.



Playfield Top - Hex Spacers Continued

3A *Item 3A Note: Quantity 4 on the Static Shield located on the Speaker Panel; Quantity 1 on the Display Controller PCB (both in Backbox).*

Take Note:

Legend Note:
Items noted with a white square are Hex Spacers.

The item type (size / description), the quantity and/or location used, are subject to change without notice. Service Bulletins will announce any changes, if warranted.

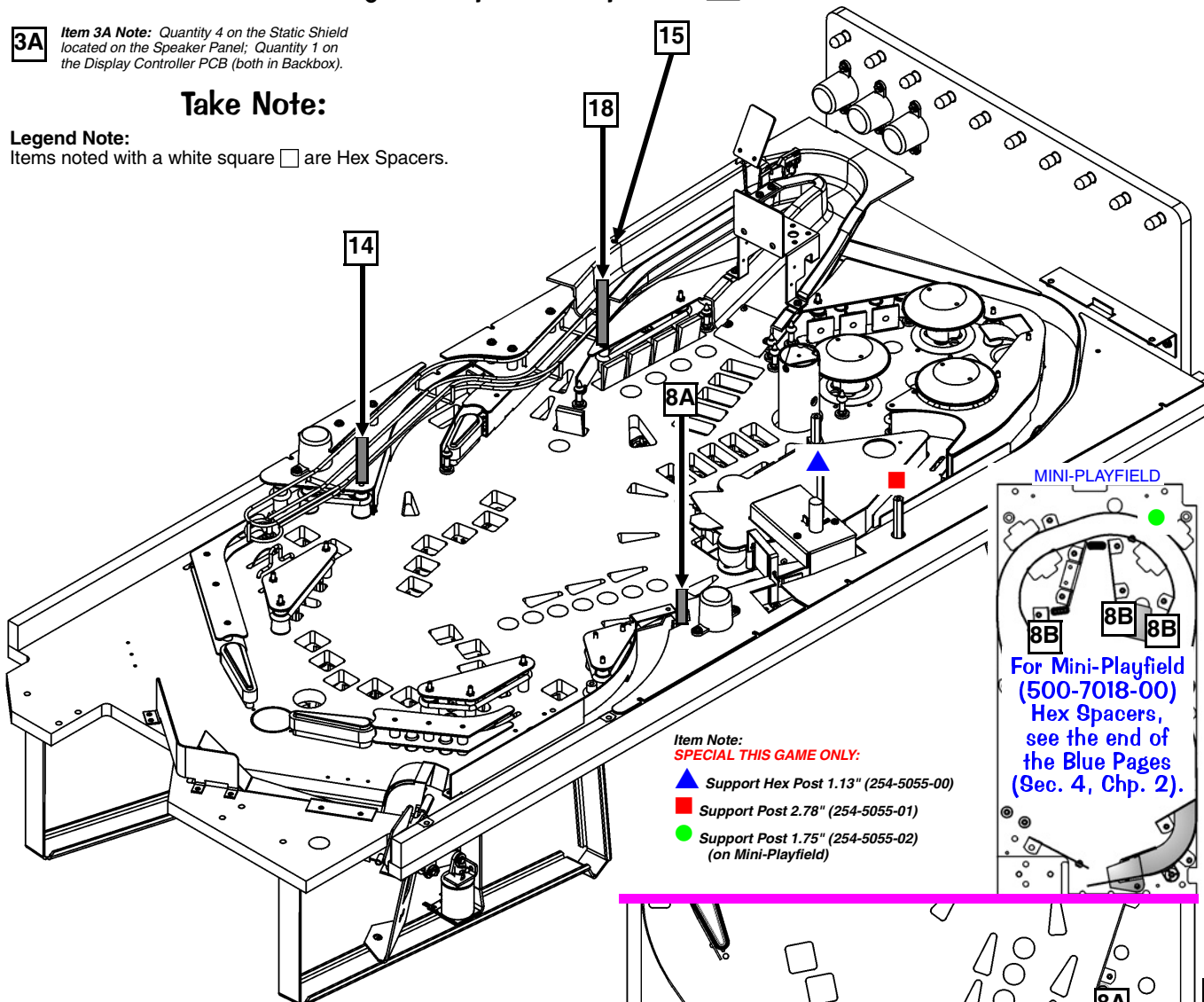

- Item Note:**
SPECIAL THIS GAME ONLY:
- ▲ Support Hex Post 1.13" (254-5055-00)
 - Support Post 2.78" (254-5055-01)
 - Support Post 1.75" (254-5055-02) (on Mini-Playfield)

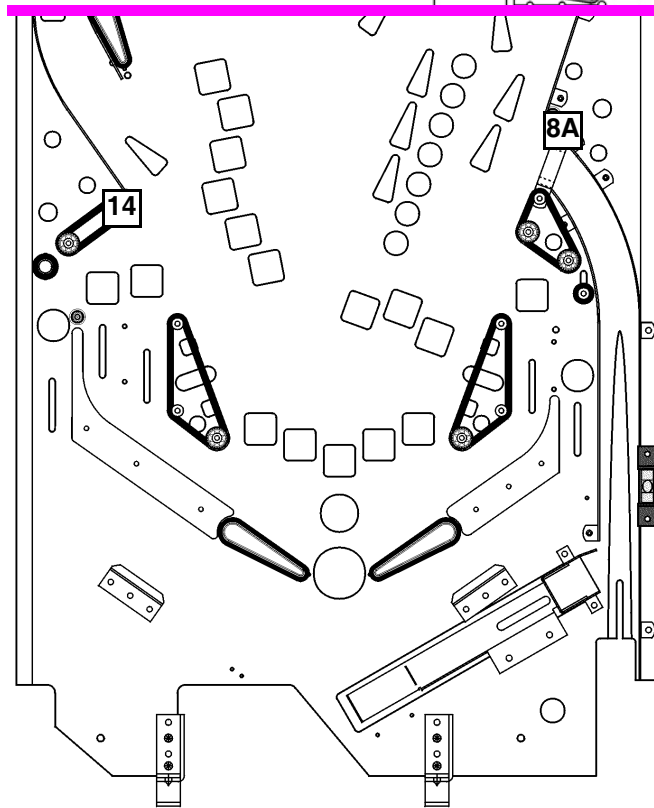
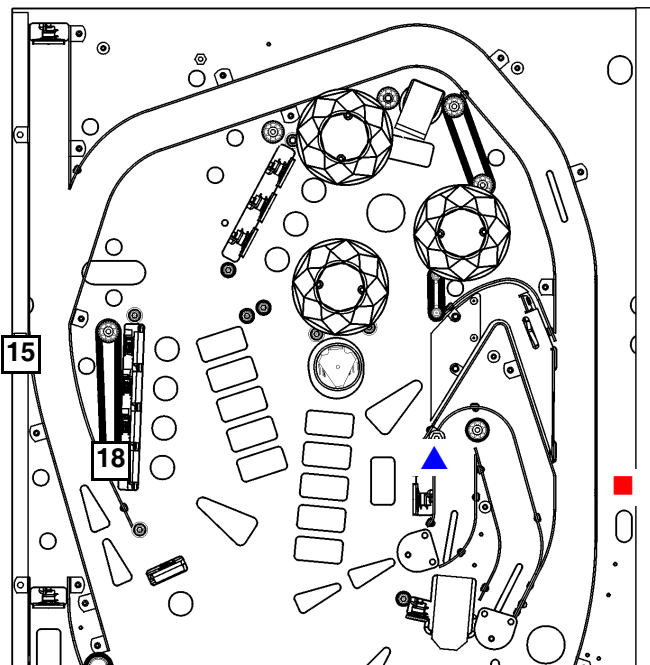
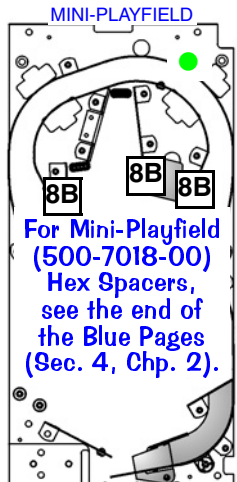

Sec. 4: Parts Id. ...

Playfield Top - Plastic Posts & Spacers & Metal Spacers (Actual Size) †

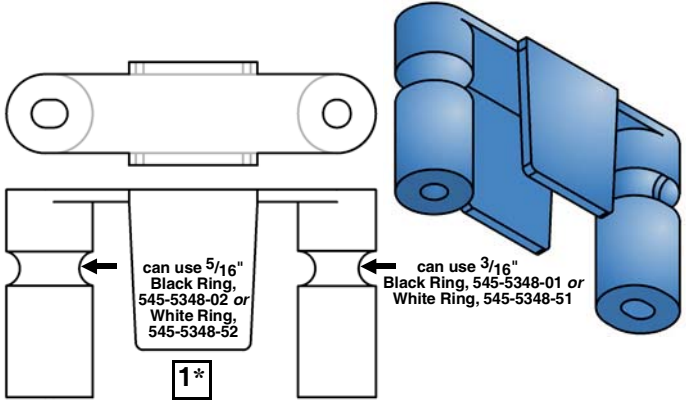

can use 5/16" Black Ring, 545-5348-02 or White Ring, 545-5348-52

can use 3/16" Black Ring, 545-5348-01 or White Ring, 545-5348-51

Take Note:

PLASTIC PART COLOR CHART

Nr.	Color	Nr.	Color	Nr.	Color
-00	Black	-06	Yellow	-12	Fluor. Blue
-01	Clear	-07	Orange	-13	Teal Green
-02	Red	-08	White	-14	Gray
-03	Amber	-09	Purple	-15	Luminescent
-04	Green	-10	Fluor. Orange	-16	Gold
-05	Blue	-11	Fluor. Green		

* Items 1 & 5 come in various colors. The "-XX" (last 2-Digits in part number), should be replaced with the desired 2-Digit number from the above Color Chart (may not be available in every color; other colors used in prior games may no longer be available).

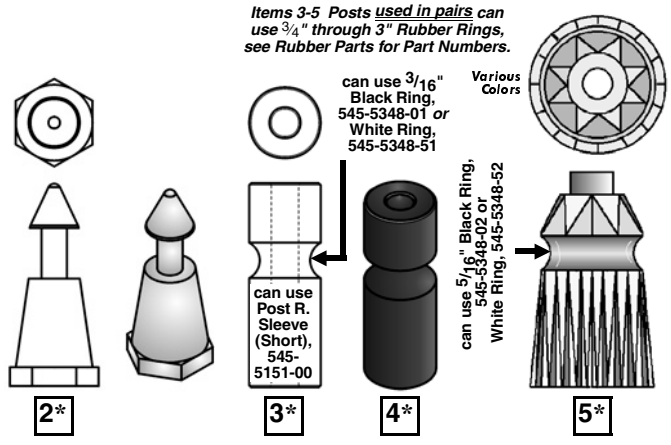

Items 3-5 Posts used in pairs can use 3/4" through 3" Rubber Rings, see Rubber Parts for Part Numbers.

can use 3/16" Black Ring, 545-5348-01 or White Ring, 545-5348-51

Various Colors

can use 5/16" Black Ring, 545-5348-02 or White Ring, 545-5348-52

can use 5/16" Black Ring, 545-5348-02 or White Ring, 545-5348-52

Take Note:

PLASTIC PART COLOR CHART

Nr.	Color	Nr.	Color	Nr.	Color
-00	Black	-06	Yellow	-12	Fluor. Blue
-01	Clear	-07	Orange	-13	Teal Green
-02	Red	-08	White	-14	Gray
-03	Amber	-09	Purple	-15	Luminescent
-04	Green	-10	Fluor. Orange	-16	Gold
-05	Blue	-11	Fluor. Green		

* Items 1 & 5 come in various colors. The "-XX" (last 2-Digits in part number), should be replaced with the desired 2-Digit number from the above Color Chart (may not be available in every color; other colors used in prior games may no longer be available).

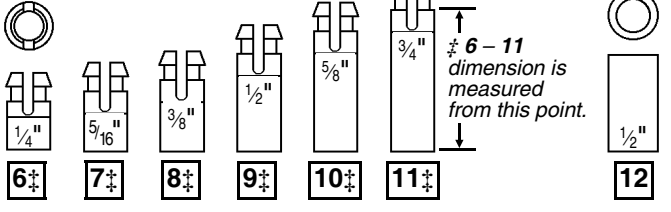

‡ Items 6 through 11 dimensions are measured from bottom to just under the cut-away. Item 32 dimension is measured from top-to-top of curve. See pictorials with Items 11 & 32.

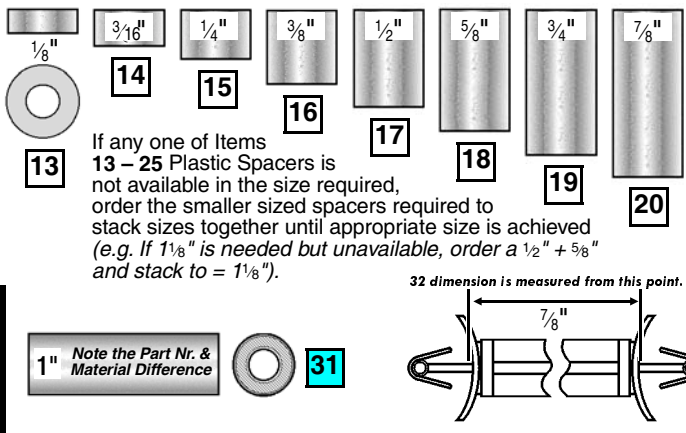

If any one of Items 13 – 25 Plastic Spacers is not available in the size required, order the smaller sized spacers required to stack sizes together until appropriate size is achieved (e.g. If 1 1/8" is needed but unavailable, order a 1/2" + 5/8" and stack to = 1 1/8").

32 dimension is measured from this point.

1" Note the Part Nr. & Material Difference

Sec. 4: Parts Id. ...

Nr.	PLASTIC POSTS & SPACERS	QTY.	SPI PART Nr.
1*	Top Lane Plastic Mini-Lite Hood		550-5061-XX
Item 2 typically secured by: #6-32 X 1-3/4" PPH MS (Zinc) (Qty. 2/per) (237-5511-00) and Washer 9/64" X 5/16" OD X 1/32" (Qty. 2/per) (242-5017-00), if used.			
2**	Mini-Jewel Plastic Post (Clear)		550-5052-01
Item 3 typically secured by: #6 X 3/8" HWH AB (Zinc) (Qty. 1/per) (234-5000-00)			
3**	1 1/16" 1-Groove Plastic Post (Clear)	14/4	550-5059-01
4**	1 1/16" 1-Groove Plastic Post (Black)		550-5059-00
5**	1-Groove Jewel Plastic Post (Clear)	11	550-5034-01
Items 4 & 5 typically secured by: Post Fastening Screw #6-32 Top / #6-32 Bottom (Qty. 1/per) (530-5012-02) For view of post, see Item 2, Page 54.			
6 ‡	1/4" Slf. Rtn. Plastic Spacer White	2/5	254-5007-02
7 ‡	5/16" Slf. Rtn. Plastic Spacer White	9	254-5007-05
8 ‡	3/8" Slf. Rtn. Plastic Spacer White	*	254-5007-01
9 ‡	1/2" Slf. Rtn. Plastic Spacer White		254-5007-04
10 ‡	5/8" Slf. Rtn. Plastic Spacer White	0/4	254-5007-00
11 ‡	3/4" Slf. Rtn. Plastic Spacer White		254-5007-03
12	1/2" X 1/4" Plastic Spacer White (Narrow)		254-5000-03
13	1/8" X 3/8" Plastic Spacer Gray		254-5000-19
14	3/16" X 3/8" Plastic Spacer Gray	4/1	254-5000-18
15	1/4" X 3/8" Plastic Spacer Gray	2/2	254-5000-02

Nr.	PLASTIC POSTS & SPACERS	QTY.	SPI PART Nr.
16	3/8" X 3/8" Plastic Spacer Gray	0/1	254-5000-12
17	1/2" X 3/8" Plastic Spacer Gray	0/1	254-5000-01
18	5/8" X 3/8" Plastic Spacer Gray	6	254-5000-14
19	3/4" X 3/8" Plastic Spacer Gray	7/3	254-5000-07
20	7/8" X 3/8" Plastic Spacer Gray		254-5000-11
21	1" X 3/8" Plastic Spacer Gray or Black	2/2	254-5000-04
22	1 1/8" X 3/8" Plastic Spacer Gray		254-5000-06
	1 1/8" X 3/8" Plastic Spacer Natural		254-5000-06N
23	1 1/4" X 3/8" Plastic Spacer Gray	8	254-5000-05
24	1 1/2" X 3/8" Plastic Spacer Gray		254-5000-08
25	1 5/8" X 3/8" Plastic Spacer Gray		254-5000-15
26	1/4" X 5/16" X .144" I.D. Metal Spacer		254-5014-03
27	1/2" X 5/16" X .144" I.D. Metal Spacer		254-5014-00
28	9/16" X 5/16" X .144" I.D. Metal Spacer		254-5014-04
29	3/4" X 5/16" X .144" I.D. Metal Spacer		254-5014-01
30	1 1/8" X 5/16" X .144" I.D. Metal Spacer		254-5014-02
31	1" X 5/16" X .144" I.D. Metal Spacer		254-5001-00
32 ‡	7/8" Plastic Spacer Support (Dual-Locking)		254-5039-14

Note: # / x X = Mini-Pinball Qty. See Pages 90-94.



† The item type (size / description), the quantity and/or location used, are subject to change without notice. Service Bulletins will announce any changes, if warranted.

Playfield Top & Bottom - Rubber Parts Black & White (Rings Actual Size) †

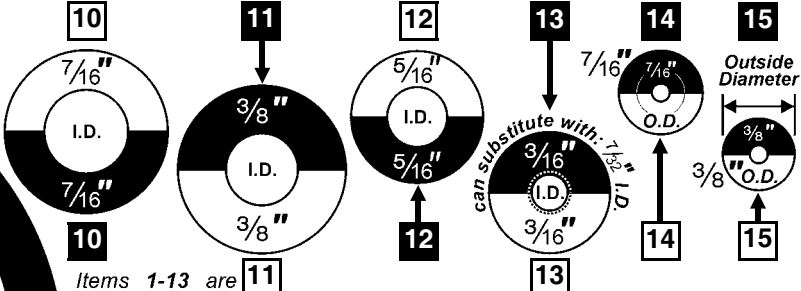
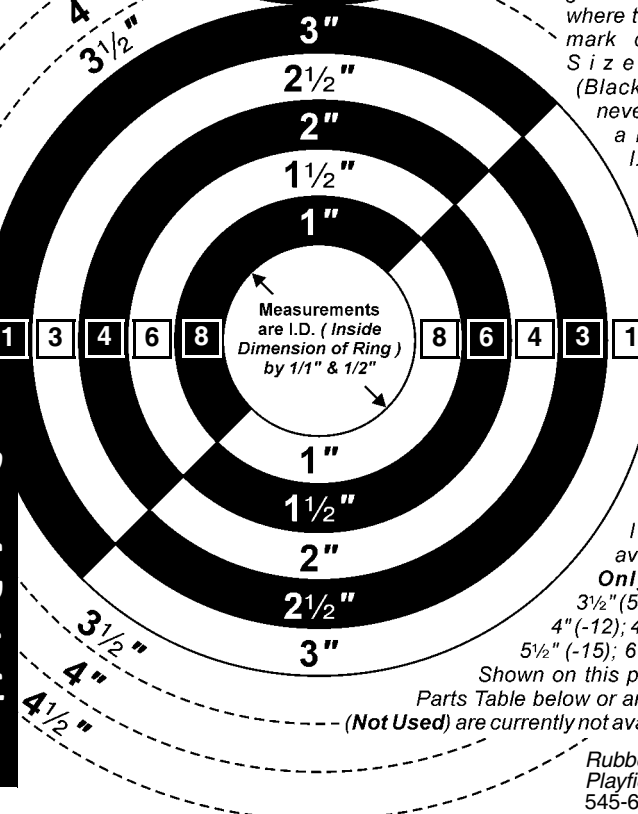
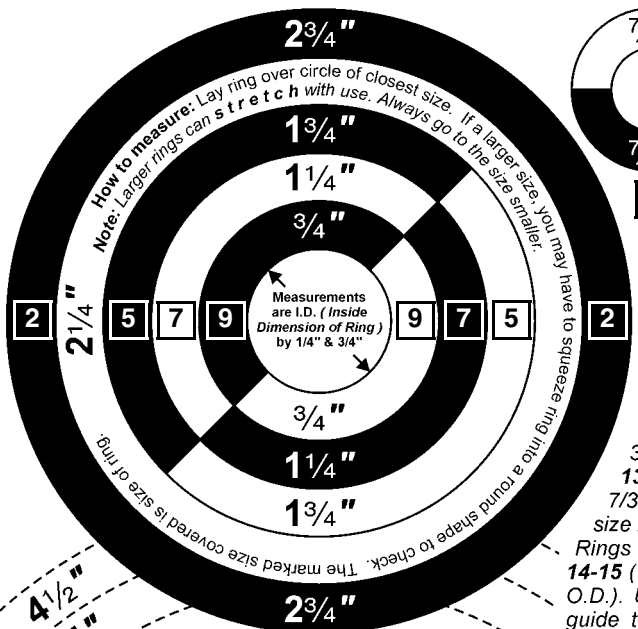

Nr.	RUBBER RINGS	QTY.	SPI PART Nr.
1	3" I.D. Rubber Ring BLACK		545-5348-10
	3" I.D. Rubber Ring WHITE		545-5348-60
2	2 3/4" I.D. Rubber Ring BLK		545-5348-20
	2 3/4" I.D. Rubber Ring WHT	N/U	545-5348-70
3	2 1/2" I.D. Rubber Ring BLK		545-5348-09
	2 1/2" I.D. Rubber Ring WHT		545-5348-59
4	2" I.D. Rubber Ring BLACK	3	545-5348-08
	2" I.D. Rubber Ring WHITE		545-5348-58
5	1 3/4" I.D. Rubber Ring BLK		545-5348-21
	1 3/4" I.D. Rubber Ring WHT	N/U	545-5348-71
6	1 1/2" I.D. Rubber Ring BLK	1	545-5348-07
	1 1/2" I.D. Rubber Ring WHT		545-5348-57
7	1 1/4" I.D. Rubber Ring BLK	1	545-5348-06
	1 1/4" I.D. Rubber Ring WHT		545-5348-56
8	1" I.D. Rubber Ring BLACK	1	545-5348-05
	1" I.D. Rubber Ring WHITE		545-5348-55
9	3/4" I.D. Rubber Ring BLACK	1	545-5348-04
	3/4" I.D. Rubber Ring WHITE		545-5348-54
10	7/16" I.D. Rubber Ring BLK		545-5348-18
	7/16" I.D. Rubber Ring WHT		545-5348-68
11	3/8" I.D. Rubber Ring BLACK	1	545-5348-03
	3/8" I.D. Rubber Ring WHITE	N/U	545-5348-53
12	5/16" I.D. Rubber Ring BLK	3	545-5348-02
	5/16" I.D. Rubber Ring WHT		545-5348-52
13	3/16" I.D. Rubber Ring BLK	1	545-5348-01
	3/16" I.D. Rubber Ring WHT		545-5348-51
14	7/16" O.D. Rubber Ring BLK	47/2	545-5348-17
	7/16" O.D. Rubber Ring WHT		545-5348-67
	<i>Note: Item 14, 7/16" O.D. Black Rings (Qty. 35 of 46) are used to cushion the Bayonet Sockets under the playfield (between bracket & playfield).</i>		
15	3/8" O.D. Rubber Ring BLK		545-5348-19
	3/8" O.D. Rubber Ring WHT	0/5	545-5348-69
16	Small Flipper BLACK Ring (Soft Duro)	1	545-5207-00
	Small Flipper RED Ring (Soft Duro)		545-5207-22
	Large Flipper BLACK Ring (50 Duro)	2	545-5277-00
	Large Flipper YELLOW Ring (50 Duro) (use -06 40 Duro)		545-5277-04
17	Large Flipper WHITE Ring (50 Duro)		545-5277-08
	Large Flipper RED Ring (Soft Duro)		545-5277-22
18	O-Ring (1 1/32" I.D. x 7/32" O.D. x 1/16")	0	545-5850-00
	<i>(Located inside Cabinet with each Flipper Button Assembly)</i>		

Sec. 4: Parts Id. ...

Nr.	RUBBER BUMPER PADS	QTY.	SPI PART Nr.
A*	Bumper BLK Pad (Lg. w/ grommet)		545-5428-00
	<i>Item B are located on Flipper Assemblies. See next page for location.</i>		
B*	Bumper BLK Pad (Sm. w/ grommet)	3/3	545-5105-00
	<i>Item B are located on multiple assemblies. See next page for location.</i>		
Nr.	RUBBER ... POST SLEEVES	QTY.	SPI PART Nr.
C*	Bumper BLACK Post Sleeve (Tall)		545-5308-00
	<i>Item C in RED use 545-5308-22; Item C in WHITE use 545-5308-08.</i>		
D*	Bumper Post Sleeve (Short)		545-5151-00

Note: Sizes larger than 3" I.D. currently available in **Black Only (Not Used)**: 3 1/2" (545-5348-11); 4" (-12); 4 1/2" (-13); 5" (-14); 5 1/2" (-15); 6" (-16). Sizes Not Shown on this page, listed in the Parts Table below or are noted with **N/U** (Not Used) are currently not available.

Rubber Rings on Mini-Playfield Flippers 545-6187-00 (Qty. 2) Not Shown This Page

Take Note:

* An asterisk (*) indicates view of item on the Assembly Drawing only (for location see next page). For better view(s), see **Drawings for Major Assemblies...** (The Blue Pages), Section 4, Chapter 2, (Page 65), (view Table of Contents for exact page).

Legend Note:
Items noted with a black square ■ are Black Rubber Parts.
Items noted with a white square □ are White Rubber Parts.

† The item type (size / description), the quantity and/or location used, are subject to change without notice. Service Bulletins will announce any changes, if warranted.

Note: # / x X = Mini-Pinball Qty. See Pages 90-94.



Playfield Top & Bottom - Rubber Parts Black ■ & White □ Continued

Item B Note:
 Located **below** ~ on three (3) assemblies:
 4-Ball Trough (Page 67), Scoop & VUK (Page 74) and Eject / VUK (Page 75)

Take Note:

Legend Note:
 Items noted with a black square ■ are Black Rubber Parts.
 Items noted with a white square □ are White Rubber Parts.

The item type (size / description), the quantity and/or location used, are subject to change without notice. Service Bulletins will announce any changes, if warranted.

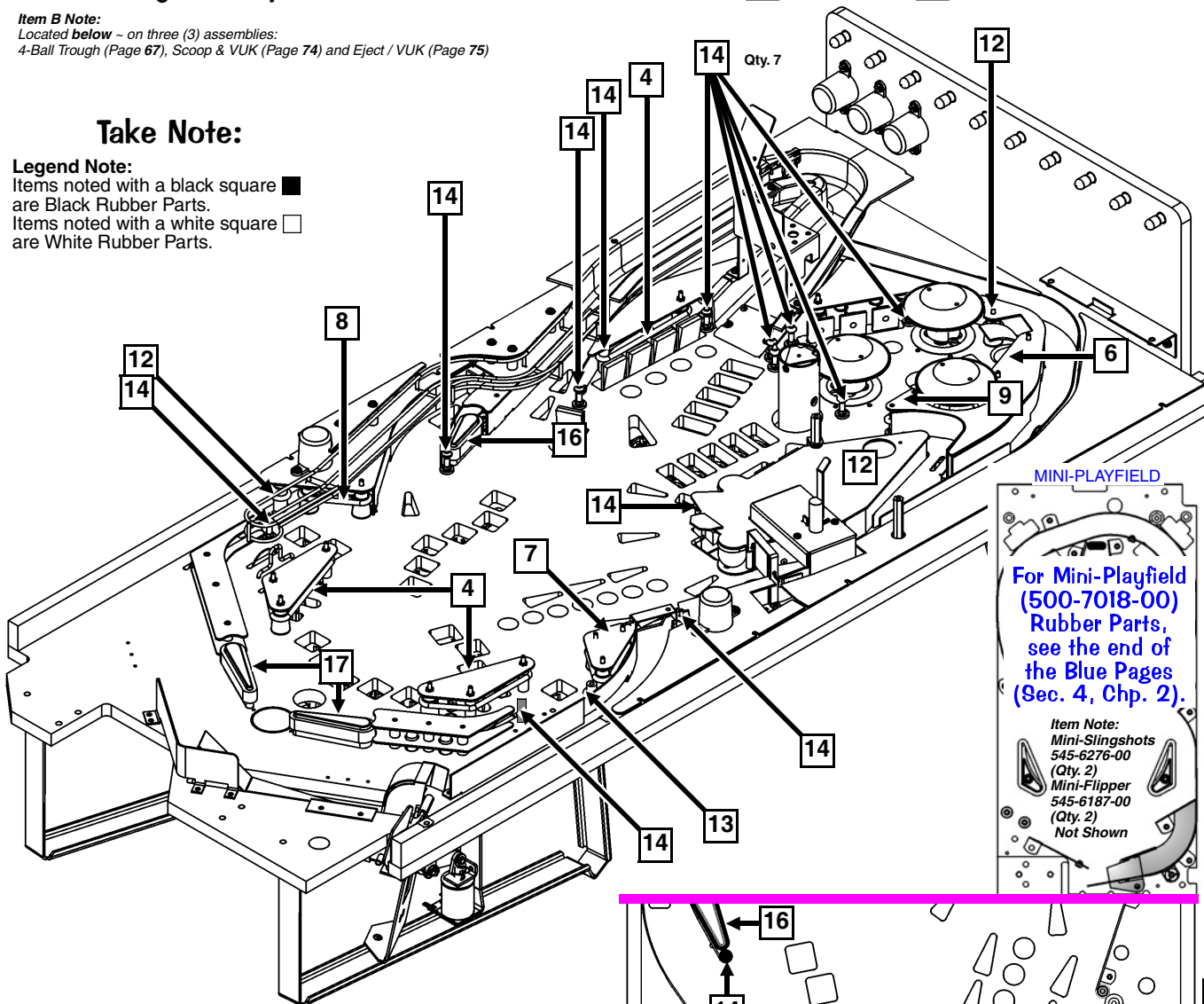

MINI-PLAYFIELD

For Mini-Playfield (500-7018-00) Rubber Parts, see the end of the Blue Pages (Sec. 4, Chp. 2).

Item Note:
 Mini-Slingshots
 545-6276-00
 (Qty. 2)
 Mini-Flipper
 545-6187-00
 (Qty. 2)
 Not Shown

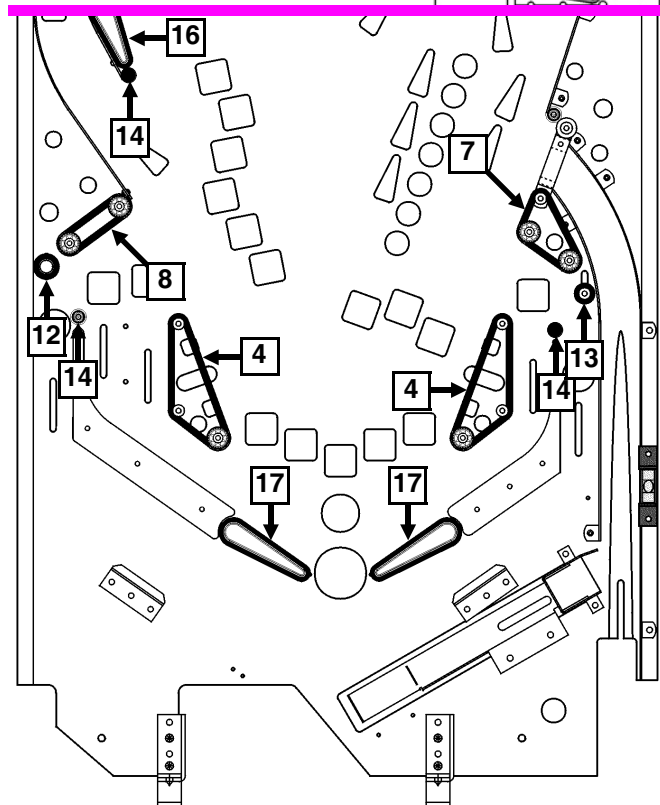
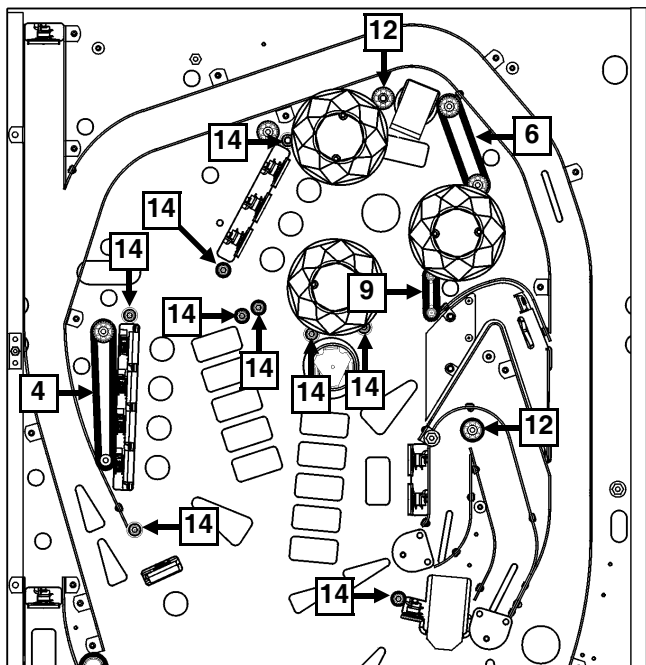

Sec. 4: Parts Id. ...

Playfield Top & Bottom - Small Bayonet Sockets & Bulbs (Actual Size) †

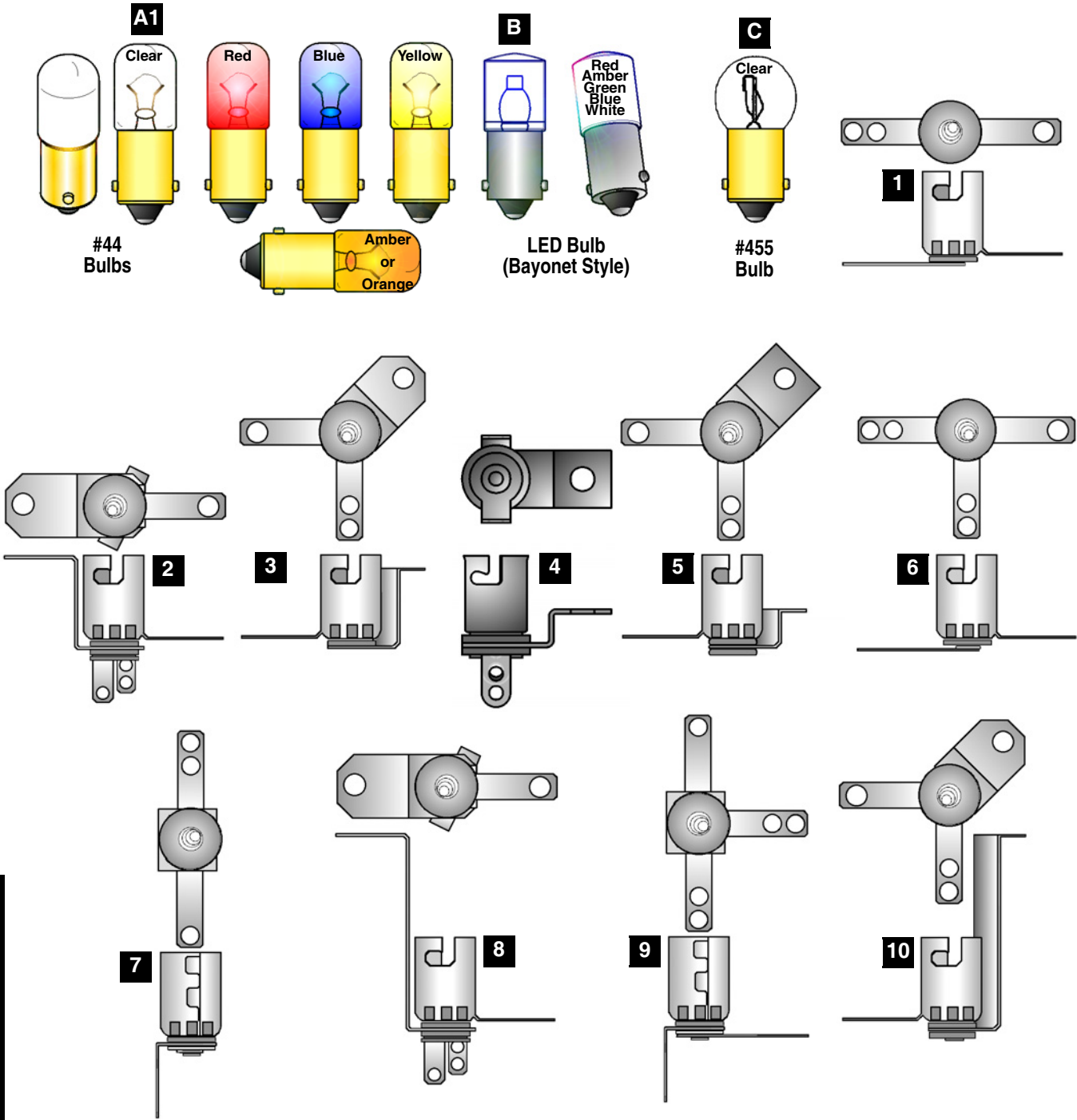

Sec. 4: Parts Id. ...

† The item type (size / description), the quantity and/or location used, are subject to change without notice. Service Bulletins will announce any changes, if warranted.

Nr.	BULBS (#44)	QTY.	SPI PART Nr.	Nr.	BULBS (LED & #455)	QTY.	SPI PART Nr.
A	#44 Bulb (Clear) Heavy Filament	33/1	165-5000-44-HF	B	LED Module (WHT) (12.8v 20-25mA) Bynt.		112-5023-08
	#44 Bulb (Yellow)	10	165-5053-06-HF		<i>Item B Note: Different Colors available (not used in this game) ~</i>		
	<i>Item A Note: Different Colors available ~ Green (165-5053-04-HF)</i>				<i>Red (112-5023-02); Amber (112-5023-03); Green (112-5023-04); Blue (112-5023-05);</i>		
	<i>Red (165-5053-02-HF); Amber (165-5053-03-HF); Blue (165-5053-05-HF); Orange (165-5053-07-HF)</i>			C	#455 Twinkle Bulb		165-5003-00

Nr.	SMALL BAYONET SOCKETS	QTY.	SPI PART Nr.	Nr.	SMALL BAYONET SOCKETS	QTY.	SPI PART Nr.
1	2-Lug Staple Down Socket	14	077-5000-00	9	3-Lug Laydown Socket (3 Lugs Flat)		077-5006-00
2	3-Lug Stand-Up Socket (Med. Brkt.)		077-5008-00	10	2-Lug Stand-Up Socket (Tall Bracket)		077-5005-00
3	2-Lug Stand-Up Socket (Med. Brkt.)		077-5002-00	11	3-Lug Stand-Up Long Shell Socket		077-5013-00
4	2-Lug Stand-Up Socket (Short Brkt.)		077-5223-00	12	2-Lug Stand-Up Lg. Shell Socket (Gls)	18	077-5031-00
5	2-Lug Stand-Up Sckt. (Short Bracket)		077-5002-31	13	1-Lug S-U Lg. Shell Sckt. (Med. Brkt.)		077-5012-00
6	3-Lug Staple Down Socket		077-5001-00	14	3-Lug S-U Lg. Shell Sckt. (45° Brkt.)	10/1	077-5035-00
7	2-Lug Laydown Socket		077-5003-00	15	3-Lug Laydown Socket (2 Lugs Bent)	1	077-5032-00
8	3-Lug Stand-Up Socket (Tall Bracket)		077-5009-00				

Note: # / x X = Mini-Pinball Qty.
See Pages 90-94.



Playfield Top & Bot. - Small Bayonet Sockets & Bulbs ■ (Actual Size) † Continued

† The item type (size / description), the quantity and/or location used, are subject to change without notice. Service Bulletins will announce any changes, if warranted.

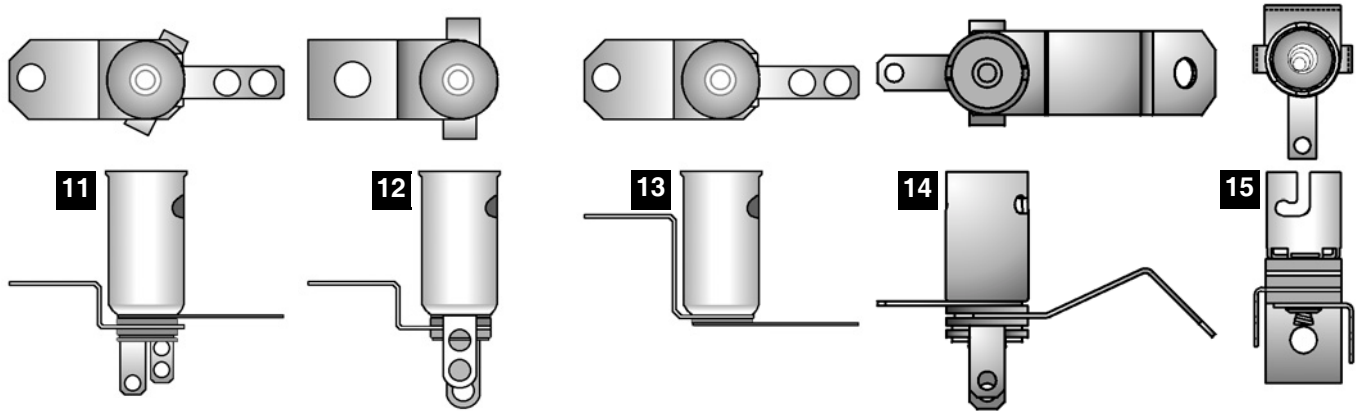

Playfield Bottom - Large Bayonet Sockets & Bulbs ■ (Actual Size) †

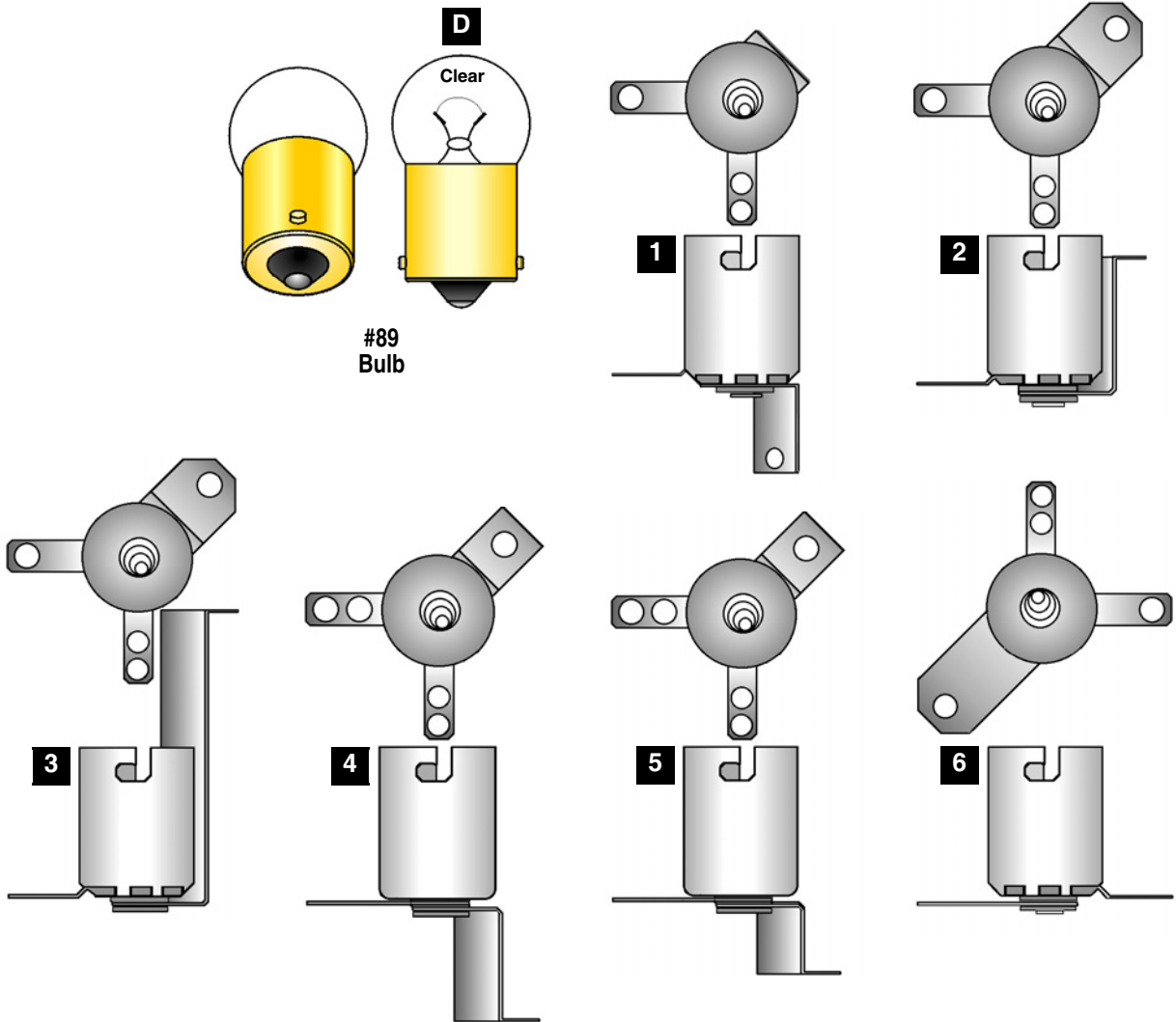

Nr.	BULBS (#89)	QTY.	SPI PART Nr.
D	#89 Bulb Heavy Filament	8	165-5000-89-HF

Nr.	LARGE BAYONET SOCKETS	QTY.	SPI PART Nr.	Nr.	LARGE BAYONET SOCKETS	QTY.	SPI PART Nr.
1	2-Lug Laydown Standard Socket		077-5100-00	4	2-Lug Stand-Up Rev. Mount Socket		077-5103-00
2	2-Lug Stand-Up Short Socket	3	077-5101-00	5	2-Lug Stand-Up Rv. Mnt. Short Socket	3	077-5106-00
3	2-Lug Stand-Up Long Socket	2	077-5102-00	6	2-Lug Straight Leg Socket		077-5107-00

Sec. 4: Parts Id. ...

Playfield Top & Bottom - Wedge Base Sockets & Bulbs (Actual Size) †

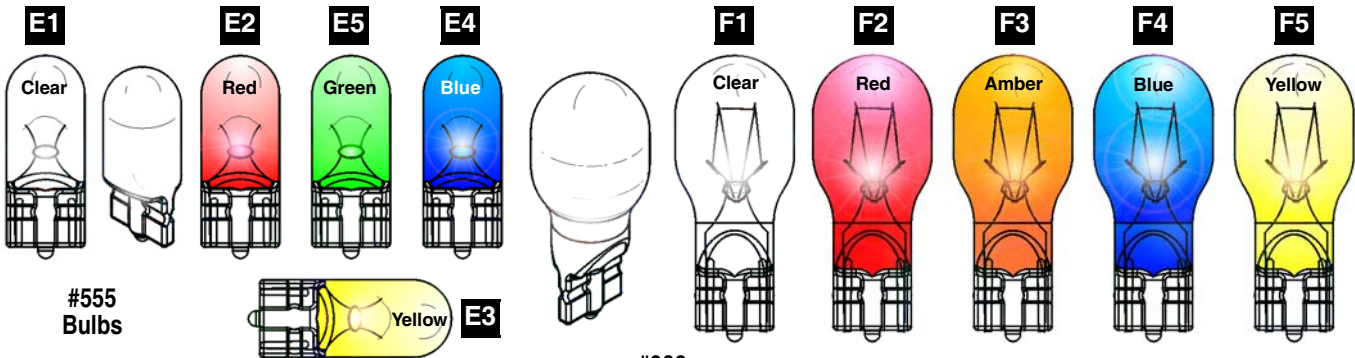

#555 Bulbs

#906 Bulbs

Note: Always replace with same type bulb in original application.

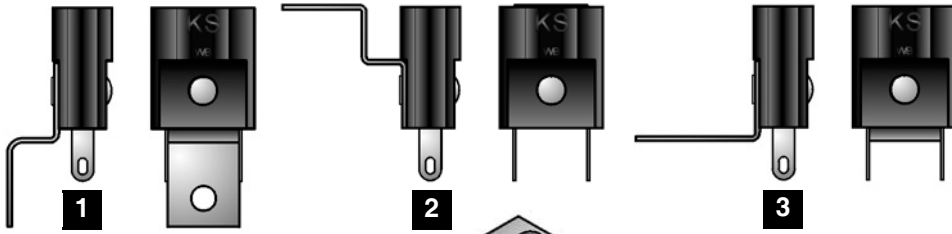

LED Bulb (Wedge Base)

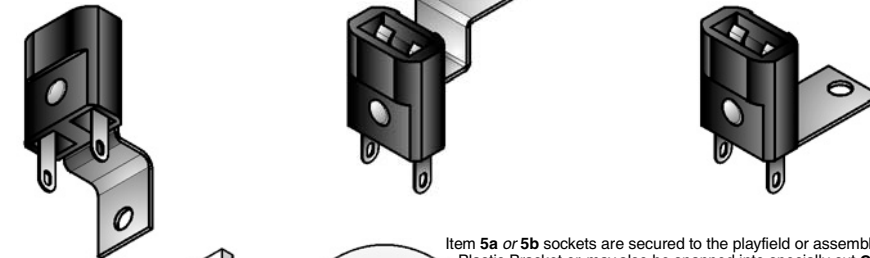

Item 4 Socket does not require brackets. Old stock may include "L" style brackets (each side); do not secure to assembly. Black Wires (Qty. 2) are 12" each.

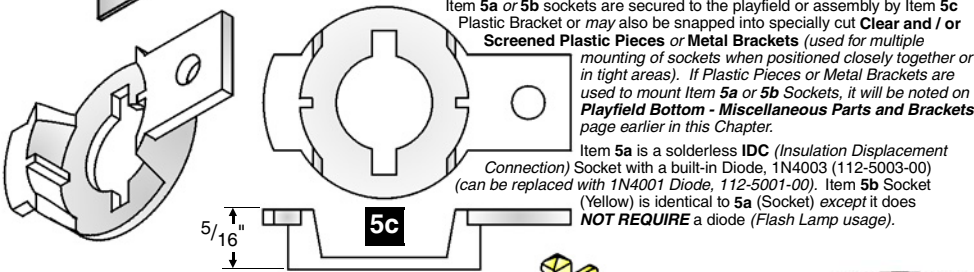
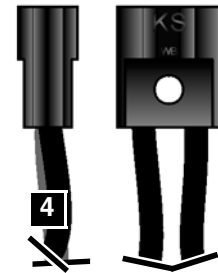

Item 5a or 5b sockets are secured to the playfield or assembly by Item 5c Plastic Bracket or may also be snapped into specially cut Clear and / or Screened Plastic Pieces or Metal Brackets (used for multiple mounting of sockets when positioned closely together or in tight areas). If Plastic Pieces or Metal Brackets are used to mount Item 5a or 5b Sockets, it will be noted on Playfield Bottom - Miscellaneous Parts and Brackets, page earlier in this Chapter.

Item 5a is a solderless IDC (Insulation Displacement Connection) Socket with a built-in Diode, 1N4003 (112-5003-00) (can be replaced with 1N4001 Diode, 112-5001-00). Item 5b Socket (Yellow) is identical to 5a (Socket) except it does NOT REQUIRE a diode (Flash Lamp usage).

Just squeeze the "side arms" of the socket together and pull away from the plastic or bracket for easy Bulb replacement.

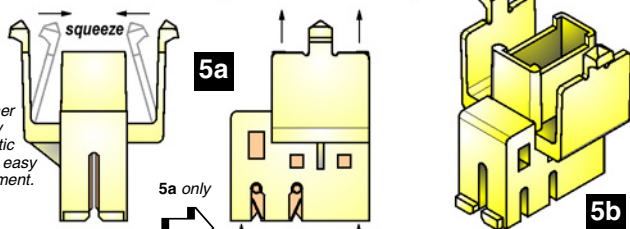

5b is Yellow with No Diode

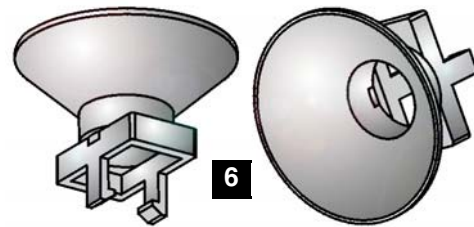

6

Sec. 4: Parts Id. ...

Nr.	BULBS (#555 & LED)	QTY.	SPI PART Nr.	Nr.	BULBS (#906)	QTY.	SPI PART Nr.
E1	#555 Wedge Base Bulb (Clear)	56/2	165-5002-00	F	#906 Wedge Base Bulb (Clear)		165-5004-00
E2-E5	#555 Wedge Base Bulb (Multi-Color)		165-5054-XX	Item F Note: Different Colors available (not used in this game) - Red (165-5004-02); Amber (165-5004-03); Blue (165-5004-05); Yellow (165-5004-06) Ordering Note: C86 / CM86 / #86 6.3V Mini-Wedge Base Bulb (Clear) used inside the Tournament Button (as described in Section 4, Chapter 1, (The Pink Pages) Parts Identification & Location, Cabinet - Parts & Switches, Item 11T), use Part Number 165-5002-01. Neon Bulb (Spike Suppression / Connector for Motors) NE-2 (A1A), use PN 165-5021-00.			
E6	LED Module (WHT) (5v - 6.3v) Wedge Base	2	112-5024-08	Item E6 Bulb Note: If LED is not a Module and connected with 2 leads soldered to a Terminal Strip 3-Lug with 3X Resistors under Playfield, call Tech Support for Part Number.			
Nr.	WEDGE BASE SOCKETS	QTY.	SPI PART Nr.	Nr.	WEDGE BASE SOCKETS	QTY.	SPI PART Nr.
1	Wedge Base Socket (Laydown)	3	077-5026-01	5a	IDC Snap-On Socket (Biege)	52	077-5216-00
2	Wedge Base Socket (Offset)	1/2	077-5029-00	5b	IDC Snap-On Socket No Diode (Yel.)		077-5216-01
3	Wedge Base Socket (Laydown GI)		077-5030-00	5c	5/16" Ht. Bracket (White)		545-5760-18
4	W.B. Socket (Bumpers/Special App.)	1	077-5206-00	6	Light Reflector (Silver Plastic)		545-5409-01
				Note Item 6: Typically used with Item 1 (but will fit on any similar Wedge Base Socket).			

Note: # / x X = Mini-Pinball Qty. See Pages 90-94.



† The item type (size / description), the quantity and/or location used, are subject to change without notice. Service Bulletins will announce any changes, if warranted.

Drawings for Major Assemblies & Ramps (The Blue Pages)

Table of Contents for Section 4, Chapter 2 of 2

Table of Contents for Section 4, Chapter 2	65
Ball Shooter (Plunger) Assembly, 500-6146-00-04..... (Top)	66
▷ Assembly View ▷ Ball Shooter Parts Table	
Autoplunger Arm Weld Assembly, 500-6091-00 Autoplunger Coil Assembly, 500-6092-02-ND and Shooter Lane Switch Assembly, 500-6096-00	(Bot) 66
4-Ball Trough Assembly, 500-6318-14-ND	67
▷ Associated Parts: Ball Trough Enter/Exit Scoop, 535-7329-01; Steel Balls (1-1/16" ø), 260-5000-00	
Flipper (Left) Assembly, 500-6543-14-ND	68
▷ Associated Parts: YELLOW Flipper Bat & Shaft Asm., 515-5133-06-06; Large Flipper BLACK Rubber Ring, 545-5277-00	
Flipper (Right) Assembly, 500-6543-04-ND	69
▷ Associated Parts: YELLOW Flipper Bat & Shaft Asm., 515-5133-06-06; Large Flipper BLACK Rubber Ring, 545-5277-00	
Flipper (Upper Left) Assembly, 500-6543-35-NDM.....	70
▷ Associated Parts: YELLOW Mini-Flipper Bat & Shaft Asm., 515-6275-06; Mini-Flipper BLACK Rubber Ring, 545-5207-00	
Bumper Top, Bumper Bottom & Bumper Switch Individual Parts Only	71
▷ Associated Part: Bumper [Pop] Caps (Clear, Red & Blue), 550-5057-01, -02 & -05 (Qty. 1/per)	
Slingshot (Left & Right) Assemblies, 500-5849-02-ND (Qty. 2)	72
Up/Down Post (Center Drain) Assembly, 500-7022-00	73
Scoop & Vertical Up-Kicker (VUK) Assembly, 500-7028-00	74
Eject / Vertical Up-Kicker (VUK) Assembly, 500-6846-01	75
1-Bank Drop Target Assembly, 500-7029-01.....	76-77
4-Bank Drop Target Assembly, 500-7029-04	78-79
1- or 4-Bank Drop Target ... Disassembly Procedures	80-81
Plastic Left Ramp Asm. & Puss In Boots & Mounting Info, Individual Parts Only	82-83
Flat Rail #21 (Riveted) Assembly, 515-7607-21	(Top) 84
Flat Ramp & Flap (Riveted) Assembly, 510-5006-00	(Bot) 84
Red Wire Ramp, 535-9920-00	85
Magic Mirror [Prince Charming] Assembly, Individual Parts Only	86
Donkey & Motor Assembly, Individual Parts Only.....	87
Shrek & Mounting Info, Individual Parts Only	(Top) 88
Fiona & Mounting Info, Individual Parts Only	(Mid) 88
Gingy & Mounting Info, Individual Parts Only	(Bot) 88
Back Panel Assembly, Individual Parts Only.....	89
Donkey Mini-Pinball Assembly Overview	90-91
Mini-Playfield Flipper (Left) Assembly, 500-7019-00	(Top) 92
▷ Associated Parts: YELLOW Mini-Flipper Bat & Shaft Asm., 515-7591-06 & Mini-Flipper BLACK Rubber Ring, 545-6187-00	
Mini-Playfield Flipper (Right) Assembly, 500-7019-01	(Bot) 92
▷ Associated Parts: YELLOW Mini-Flipper Bat & Shaft Asm., 515-7591-06 & Mini-Flipper BLACK Rubber Ring, 545-6187-00	
Mini-Playfield Shooter Assembly, 500-7023-00	(Top) 93
Mini-Playfield Steel Shooter Ramp & Flap Asm. and OPTO Asm., Individual Parts Only	(Bot) 93
Mini-Playfield Plastic Ramp Assembly, Individual Parts Only	(Top) 94
Mini-Pinball Plastic Enclosure Assembly, Individual Parts Only	(Bot) 94

Ball Shooter (Plunger) Assembly, 500-6146-00-04 (Items 1-6)

Take Note:

Securing Hardware for Items 3 & 5 are also shown separated from the Ball Shooter (Plunger)

Assemble into Housing in the following order:

Rod Assembly (see Item 2), Short Spring (see Item 3), Washer (see Item 3), Bushing (see Item 4) and then ...

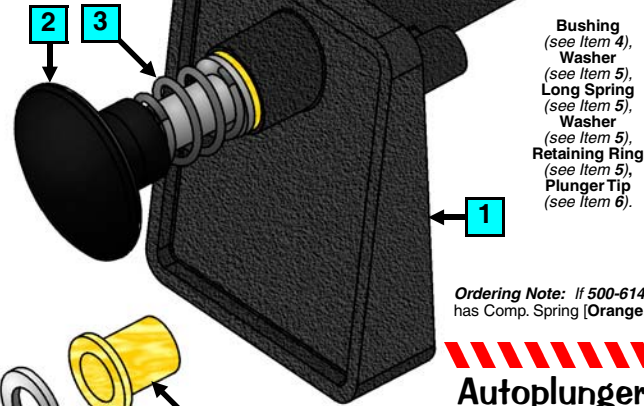

and then ...

Bushing (see Item 4), Washer (see Item 5), Long Spring (see Item 5), Washer (see Item 5), Retaining Ring (see Item 5), Plunger Tip (see Item 6).

Nr.	BALL SHOOTER PARTS	QTY.	SPI PART Nr.
1	Housing (Shooter Assembly)	1	535-5067-02
Item 1 is secured to the Cabinet by: Support Plate [not included with Item 1 or Assembly] (535-5027-00), #10-32 X 1/2" PPH (Sems) Zinc TF (Qty. 3) (237-6033-00), #10 Split Lock Washer (Qty. 3) (244-5003-00) and #6 X 1/2" HWH AB (Zinc) Red (Qty. 2) (234-5001-02)			
2	Rod Assembly (with Black Knob)	1	515-6557-00
3	Comp. Spring (Short) (Knob Side)	1	266-5010-00
Item 3 is sandwiched onto Item 2 (Front Side) between the knob and by: Washer, 3/8" I.D. X 5/8" O.D. X 1/16" (280-5010-00)			
4	Bushing, 3/8" I.D. (Oilite)	2	280-5010-00
Item 4 Note: Insert into housing (1 @ the front; 1 @ the back) as shown.			
5	Comp. Spring (Long) [GREEN , .035" ø]	1	266-5001-04
Item 5 is sandwiched onto Item 2 (Rubber Tip Side) by: Washer, 3/8" I.D. X 5/8" O.D. X 1/16" (Qty. 1/per side) (280-5010-00) and Retaining Ring, 3/8" ø Shaft (270-5012-00)			
6	Rubber [Plunger] Tip (Black 50 Duro)	1	545-5276-00

Ordering Note: If 500-6146-00-04 is unavailable, order the individual part(s) actually required. ... Identical to 500-6146-00-07 has Comp. Spring [Orange, .038" ø] (266-5001-07) or 500-6146-00-05 has Comp. Spring [Blue, .031" ø] (266-5001-05).

Autoplunger Arm Weld Asm., 500-6091-00 (Items 1-5), Autoplunger Coil Assembly, 500-6092-02-ND (Items 6-9) and Shooter Lane Switch Assembly, 500-6096-00 (Items 10-12)

Nr.	AUTOPL. ARM WELD PARTS	QTY.	SPI PART Nr.	Nr.	AUTOPLNGR. COIL PARTS	QTY.	SPI PART Nr.
1	Arm Weld Assembly	1	515-6526-00	6	Autoplunger Coil Bracket Assembly	1	515-6527-00
Item 1 is secured to Item 2 by: Retaining Ring, 1/4" ø Shaft (Qty. 1) (270-5002-00)				Items 1 & 6 are secured below the P/F by: #8 X 1/2" SHWH AB (Zc.) (Qty. 9) (234-5101-00)			
2	Autoplunger Fulcrum	1	535-7697-00	7	Coil Retainer Bracket	1	535-5203-03
3	Nyliner, 1/4" (Thomson #411-FF)	2	545-5423-00	Item 7 is secured to Item 6 by: #8-32 X 1/4" PPH MS (Sems) Zinc (Qty. 2) (232-5300-00)			
4	Plunger & Link Assembly	1	511-5183-00	8	Coil, 24-940 [NO DIODE]	1	090-5036-ND
Item 4 is secured to Item 1 by: Retaining Ring, 1/4" ø Shaft (Qty. 1) (270-5002-00)				COIL DOES NOT REQUIRE A DIODE. SEE ☺ COIL NOTE BELOW FOR DETAILS.			
For Individual Items use: Plunger 1.81" Lg. (530-5025-05), Plunger Link (545-5293-00) and Roll Pin 1/8" ø x 5/8" Lg. (251-5008-00)				9	Coil Sleeve	1	545-5031-00
5	Compression (Return) Spring	1	266-5020-00	(ASM. REF. 500-6092-02-ND, Items 6-9)			
(ASM. REF. 500-6091-00, Items 1-5)							

Nr.	SWITCH PARTS	QTY.	SPI PART Nr.
10	Switch (for Shooter Lane)	1	180-5157-00
Switch has a Diode (1N4004) (112-5003-00). Can be replaced with (1N4001) (112-5001-00).			
11	Switch Mounting Bracket	1	535-6173-00
Item 11 is secured to Playfield by: #6 X 1/2" SLT HWH AB (Zinc) (Qty. 2) (234-5001-02)			
12	Switch Body Protect Plate	1	535-6539-00
Item 12 is secured to Items 10-11 by: #2-56 X 1/2" Unslotted Ser. HWH #4 Head TR3 Black (Qty. 2) (237-5937-02) and #2-56 Hex Nut (Qty. 2) (240-5301-0) (ASM. REF. 500-6096-00, Items 10-12)			

Sec. 4: Drawings ...

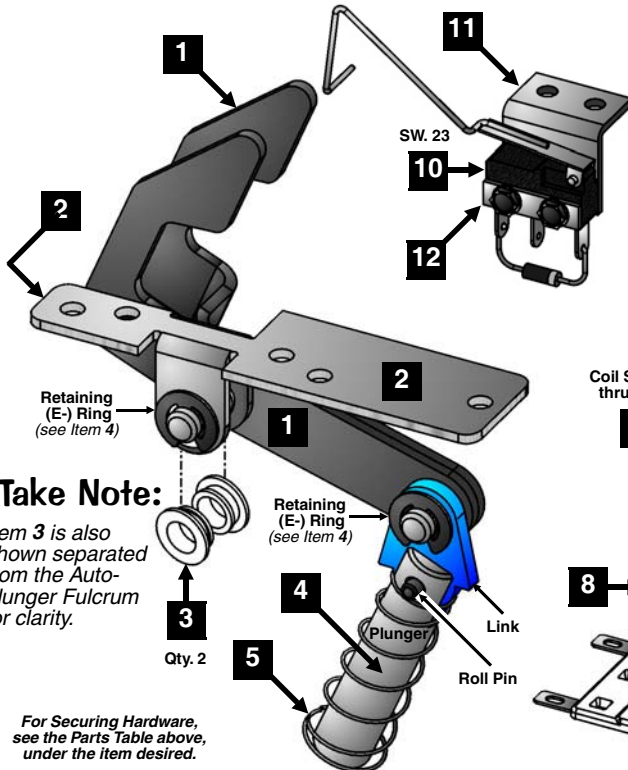

Take Note:

Item 3 is also shown separated from the Autoplunger Fulcrum for clarity.

Retaining (E-) Ring (see Item 4)

Qty. 2

Plunger Link
Roll Pin

For Securing Hardware, see the Parts Table above, under the item desired.

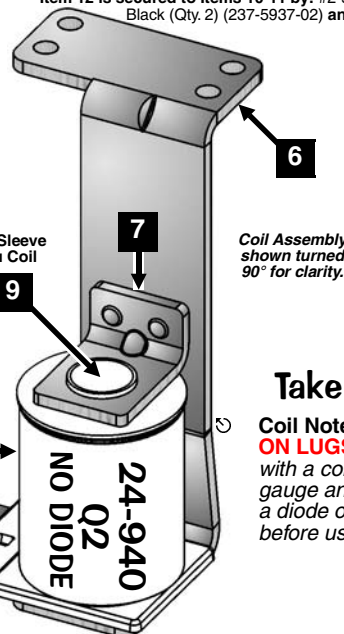

For Securing Hardware, see the Parts Table above, under the item desired.

Coil Assembly shown turned 90° for clarity.

Take Note:

Coil Note: ☺ **NO DIODE ON LUGS.** If replacing with a coil of the same gauge and turn & it has a diode on it, remove it before using.

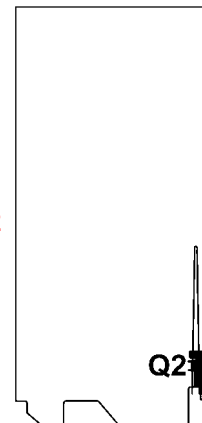

4-Ball Trough Assembly, 500-6318-14-ND (Items 1-13) and Associated Parts: See Parts Table Below.

Ordering Note: Identical to 500-6318-24 with exceptions, see note below Item 13 (Parts Table).

Nr.	4-BALL TROUGH PARTS	QTY.	SPI PART Nr.	Nr.	4-BALL TROUGH PARTS	QTY.	SPI PART Nr.
1	Ball Trough Outhole Mounting Bracket <small>Item 1 is secured below the playfield by: #8 X 1/2" SHWH AB (Zc.) (Qty. 4) (234-5101-00)</small>	1	515-6580-01	11	Trough Ball Guide Plate <small>Item 11 is secured to Item 1 by: 1/4" X 5/16" X .144" I.D. Spacer Tap. (Qty. 1) (254-5014-03) and #2-56 X 1/2" HWH (Ser) UNS #4HD TR3 BO (Qty. 4) (237-5937-02)</small>	0	535-7801-00
2	Coil Mounting Bracket <small>Item 2 is secured to Item 1 by: #8-32 X 3/8" HWH Swage (Sr.) Zinc (Qty. 4) (237-5975-00)</small>	1	535-7330-01	12	Dual OPTO TRANS Board Assembly	1	515-0173-00
3	Coil Retaining Bracket <small>Item 3 is secured to Item 2 by: #8-32 X 1/4" SHWH (Serr) Zinc (Qty. 2) (237-5975-04)</small>	1	535-5203-03	13	Dual OPTO REC Board Assembly <small>Items 12 & 13 are secured by: #6-32 X 5/8" HWH Swg (Ser) Zc (Qty. 3/per) (237-5976-04) For Individual Items use : Dual OPTO Transmitter Board (Qty. 1) (520-5173-00), Dual OPTO Receiver Board (Qty. 1) (520-5174-00), OPTO PCB Tube Spacer (Brass) (Qty. 3/per) (530-5308-02) and OPTO PCB Rubber Grommet (Qty. 3/per) (545-5518-00)</small>	1	515-0174-00
4	Coil, 26-1200 [NO DIODE] COIL DOES NOT REQUIRE A DIODE. SEE ☺ COIL NOTE BELOW FOR DETAILS.	1	090-5044-ND	Ordering Note: If 500-6318-14-ND is unavailable, order the individual part(s) actually required. This assembly is identical to 500-6318-24-ND, -15 or -25 except for the quantity of Items 9 & 10 (Qty. 4/per on 5-Ball Trough) and Item 11, required when a Magnet Mech. is used in the game (this game not required). -ND means no diode on Item 4, Coil, 26-1200.			
5	Coil Sleeve (Short) (Formost #10-7077)	1	545-5076-01	<small>ASSOCIATED PARTS ARE NOT INCLUDED WITH THE ABOVE ASSEMBLY.</small>			
6	Steel & Nylon Plunger Assembly	1	515-7309-01	Nr.	ASSOCIATED PART(S)	QTY.	SPI PART Nr.
7	Compression (Return) Spring	1	266-5020-00	AP-A	Ball Trough Enter / Exit Scoop <small>Item AP-A secured to the playfield by: #8 X 1/2" SHWH AB (Zinc) (Qty. 4) (234-5101-00).</small>	1	535-7329-01
8	Rubber Bumper (Grommet)	1	545-5105-00	AP-B	* Steel Balls (1-1/16" ø)	4	260-5000-00
9	Micro Switch (Roller Actuator, Lite-Force) <small>Item 9 requires: Heat Shrink Tubing 1/8" ø PUI-24 (Qty. 1"/per) (605-5006-00) Switch has a Diode (1N4004) (112-5003-00). Can be replaced with (1N4001) (112-5001-00).</small>	3	180-5119-02				
10	Switch Body Protect Plate	3	535-6539-00				

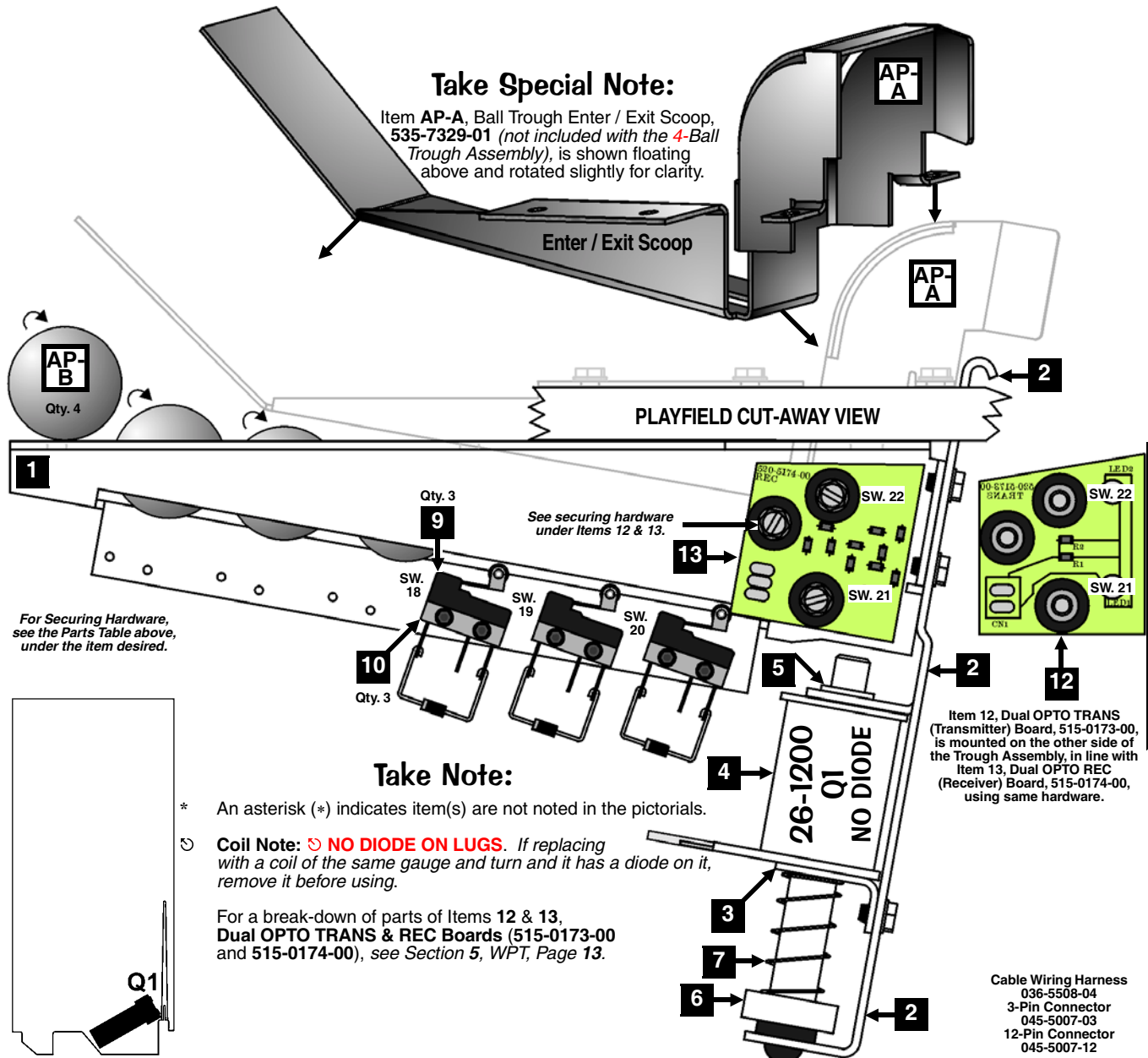

Sec. 4: Drawings ...

Flipper (Lower Left) Assembly, 500-6543-14-ND (Items 1-15) and Assoc. Parts: Yellow Flipper Bat & Shaft Assy., 515-5133-06-06 (Items AP-A/-B)



Nr.	FLIPPER (LEFT) PARTS	QTY.	SPI PART Nr.	Nr.	FLIPPER (LEFT) PARTS	QTY.	SPI PART Nr.
1	Flipper Base Plate (LEFT)	1	See FRP1	13	Crank Bar	1	530-5070-02
Item 1 is secured below the playfield by: #8 X 1/2" SHWH AB (Zc.) (Qty. 8) (234-5101-00)				Item 13 requires: Bushing, .192" ø ID X .312" ø OD X .195" (Qty. 1) (530-5139-00)			
2	Flipper Bat Bushing (White Plastic) .25" ø I.D.	1	545-5070-00	14®	Switch Actuator (LEFT) Sub-Assy.	1	515-7257-01
Item 2 is secured to Item 1 by: #6-32 X 3/8" HWH Swage (Ser.) Zc. (Qty. 3) (237-5976-02)				For Individual Items use : Actuator & Spring Bracket (LEFT) (535-9038-01) and ® Switch Actuator (White Plastic) (545-5612-00) and is secured to the Bracket by: Rivet, 1/8" ø X 1/4" Lg. (Qty. 1) (249-5003-00)			
3	Power (EOS / End-of-Stroke) Switch	1	180-5149-00	15	Set Screw: #10-32 X 3/4" Socket Hd.	2	237-6144-00
Item 3 is secured to Item 1 by: #6-32 X 5/8" HWH Swage (Ser.) Zc. (Qty. 2) (237-5976-04)				Item 15 requires: #10-32 Nylon Stop Nut (Qty. 1 Flipper Link Side Only) (240-5203-00) and #10 Split Lock Washer (244-5003-00) Tool Required for Item 15: 5/32" or 4mm Allen Wrench			
4	Sw. Plate/Spring Return Brkt. (LEFT)	1	535-7354-01	Flipper Rebuild Parts for Easier Installation, Save \$:			
5	Flipper Return Spring	1	265-5035-00	Flipper Base Plate Kit (LEFT)			
6	Coil Stop Bracket Sub-Assembly	1	515-6308-01	FRP1	Includes Item 1 pre-threaded, with the Securing Hardware for Items 2, 3, 6 & 8.		515-6617-01
Item 6 is secured to Item 1 by: #10-32 X 3/8" SHWH Swage (Serr) Zinc (Qty. 2) (237-5985-00) and #10 Split Lock Washer (Qty. 2) (244-5003-00)				Plunger, Link & Crank (LEFT) Assy.			
7	Spring Washer (17/32" ID X 3/4" X 1")	1	269-5002-00	FRP2	Includes above Items 12, 13, 14 and 15 and is pre-assembled.		515-7203-01
8	Coil Support Bracket	1	535-7356-00	Flipper (LEFT) Rebuild Kit			
Item 8 is secured to Item 1 by: #8-32 X 3/8" HWH Swage (Ser.) Zc. (Qty. 2) (237-5975-00)				FRP3	Same as FRP2, but also includes above Items 6 & 10.		500-6307-10
9	Coil, 23-1100 [NO DIODE] (Left)	1	090-5030-ND	COIL DOES NOT REQUIRE A DIODE. SEE ☺ COIL NOTE BELOW FOR DETAILS.			
10	Coil Sleeve	1	545-5388-00	ASSOCIATED PARTS ARE NOT INCLUDED WITH THE ABOVE ASSEMBLY.			
11	Deflector Pad (Bumper)	1	545-5428-00	Nr.	ASSOCIATED PART(S)	QTY.	SPI PART Nr.
12	Flipper Plunger & Link Sub-Assy.	1	515-6304-03	AP-A	YELLOW Flipper Bat (Plain) & Shaft (Non-Knurled End) Assembly	1	515-5133-06-06
For Individual Items use : Flipper Plunger (530-5349-01) and Plunger "Flipper" Link (545-5611-01) and is secured to the Plunger by: Bushing, .16" ø ID X .281" ø OD X .187" (Qty. 1) (530-5532-00) and Spiral Pin ø 5/32" X 3/4" Lg. (Qty. 1) (251-5015-02)				AP-B	Large Flipper BLACK Rubber Ring	1	545-5277-00

Sec. 4: Drawings ...

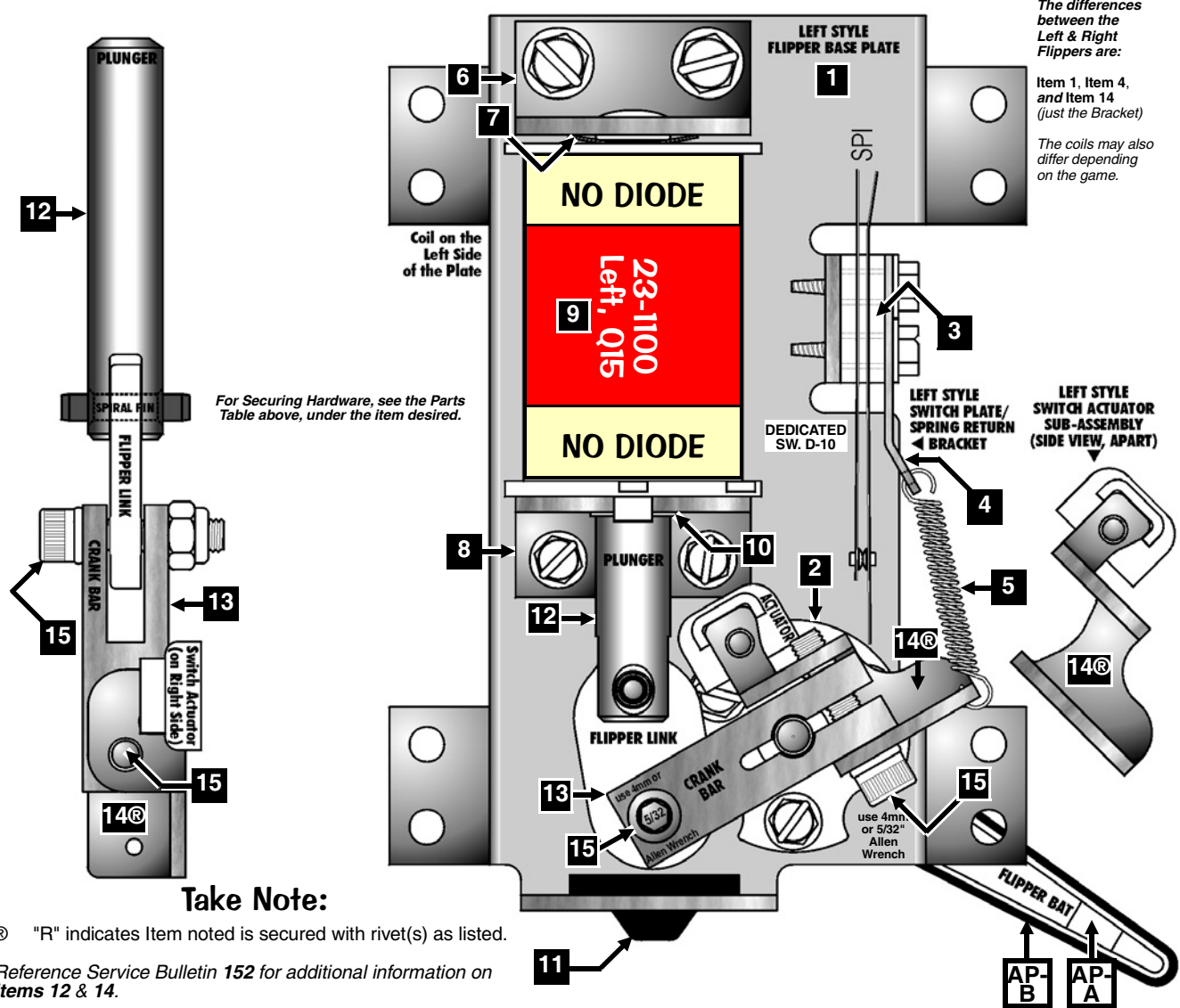

Take Note:

® "R" indicates Item noted is secured with rivet(s) as listed.

Reference Service Bulletin 152 for additional information on Items 12 & 14.



Flipper (Lower Right) Assembly, 500-6543-04-ND (Items 1-15) and Assoc. Parts: Yellow Flipper Bat & Shaft Assy., 515-5133-06-06 (Items AP-A/-B)



Nr.	FLIPPER (RIGHT) PARTS	QTY.	SPI PART Nr.	Nr.	FLIPPER (RIGHT) PARTS	QTY.	SPI PART Nr.
1	Flipper Base Plate (RIGHT)	1	See FRP1	13	Crank Bar	1	530-5070-02
Item 1 is secured below the playfield by: #8 X 1/2" SHWH AB (Zc.) (Qty. 8) (234-5101-00) Ordering Note: Use Item FRP1, see the end of this Parts Table.				Item 13 requires: Bushing, .192" ø ID X .312" ø OD X .195" (Qty. 1) (530-5139-00)			
2	Flipper Bat Bushing (White Plastic) .25" ø I.D.	1	545-5070-00	14®	Switch Actuator (RIGHT) Sub-Assy.	1	515-7257-00
Item 2 is secured to Item 1 by: #6-32 X 3/8" HWH Swage (Ser.) Zc. (Qty. 3) (237-5976-02)				For Individual Items use : Actuator & Spring Bracket (RIGHT) (535-9038-00) and ® Switch Actuator (White Plastic) (545-5612-00) and is secured to the Bracket by: Rivet, 1/8" ø X 1/4" Lg. (Qty. 1) (249-5003-00)			
3	Power (EOS / End-of-Stroke) Switch	1	180-5149-00	15	Set Screw: #10-32 X 3/4" Socket Hd.	2	237-6144-00
Item 3 is secured to Item 1 by: #6-32 X 5/8" HWH Swage (Ser.) Zc. (Qty. 2) (237-5976-04)				Item 15 requires: #10-32 Nylon Stop Nut (Qty. 1 Flipper Link Side Only) (240-5203-00) and #10 Split Lock Washer (244-5003-00) Tool Required for Item 15: 5/32" or 4mm Allen Wrench			
4	Sw. Plate/Spring Return Brkt. (RIGHT)	1	535-7354-00	Flipper Rebuild Parts for Easier Installation, Save \$:			
5	Flipper Return Spring	1	265-5035-00	Flipper Base Plate Kit (RIGHT)			
6*	Coil Stop Bracket Sub-Assembly	1	515-6308-01	FRP1	Includes Item 1 pre-threaded, with the Securing Hardware for Items 2, 3, 6 & 8.		515-6617-00
Item 6 is secured to Item 1 by: #10-32 X 3/8" SHWH Swage (Serr) Zinc (Qty. 2) (237-5985-00) and #10 Split Lock Washer (Qty. 2) (244-5003-00)				Plunger, Link & Crank (RIGHT) Assy.			
7	Spring Washer (17/32" ID X 3/4" X 1")	1	269-5002-00	FRP2	Includes above Items 12, 13, 14 and 15 and is pre-assembled.		515-7203-00
8	Coil Support Bracket	1	535-7356-00	FRP3	Flipper (RIGHT) Rebuild Kit		500-6307-00
Item 8 is secured to Item 1 by: #8-32 X 3/8" HWH Swage (Ser.) Zc. (Qty. 2) (237-5975-00)				Same as FRP2, but also includes above Items 6 & 10.			
9	Coil, 23-1100 [NO DIODE] (Right)	1	090-5030-ND				
COIL DOES NOT REQUIRE A DIODE. SEE ☺ COIL NOTE BELOW FOR DETAILS.							
10	Coil Sleeve	1	545-5388-00				
11	Deflector Pad (Bumper)	1	545-5428-00				
12	Flipper Plunger & Link Sub-Assy.	1	515-6304-03				
For Individual Items use : Flipper Plunger (530-5349-01) and Plunger "Flipper" Link (545-5611-01) and is secured to the Plunger by: Bushing, .16" ø ID X .281" ø OD X .187" (Qty. 1) (530-5532-00) and Spiral Pin ø 5/32" X 3/4" Lg. (Qty. 1) (251-5015-02)							
ASSOCIATED PARTS ARE NOT INCLUDED WITH THE ABOVE ASSEMBLY.							
Nr.	ASSOCIATED PART(S)	QTY.	SPI PART Nr.				
AP-A	YELLOW Flipper Bat (Plain) & Shaft (Non-Knurled End) Assembly	1	515-5133-06-06				
AP-B	Large Flipper BLACK Rubber Ring	1	545-5277-00				

* To Order the Flipper (Right) Rebuild Kit ask for Part Nr.: 500-6307-00 (includes Items 6, 10, 12, 13, 14 & 15)

The differences between the Left & Right Flippers are:

Item 1, Item 4, and Item 14 (just the Bracket)

The coils may also differ depending on the game.

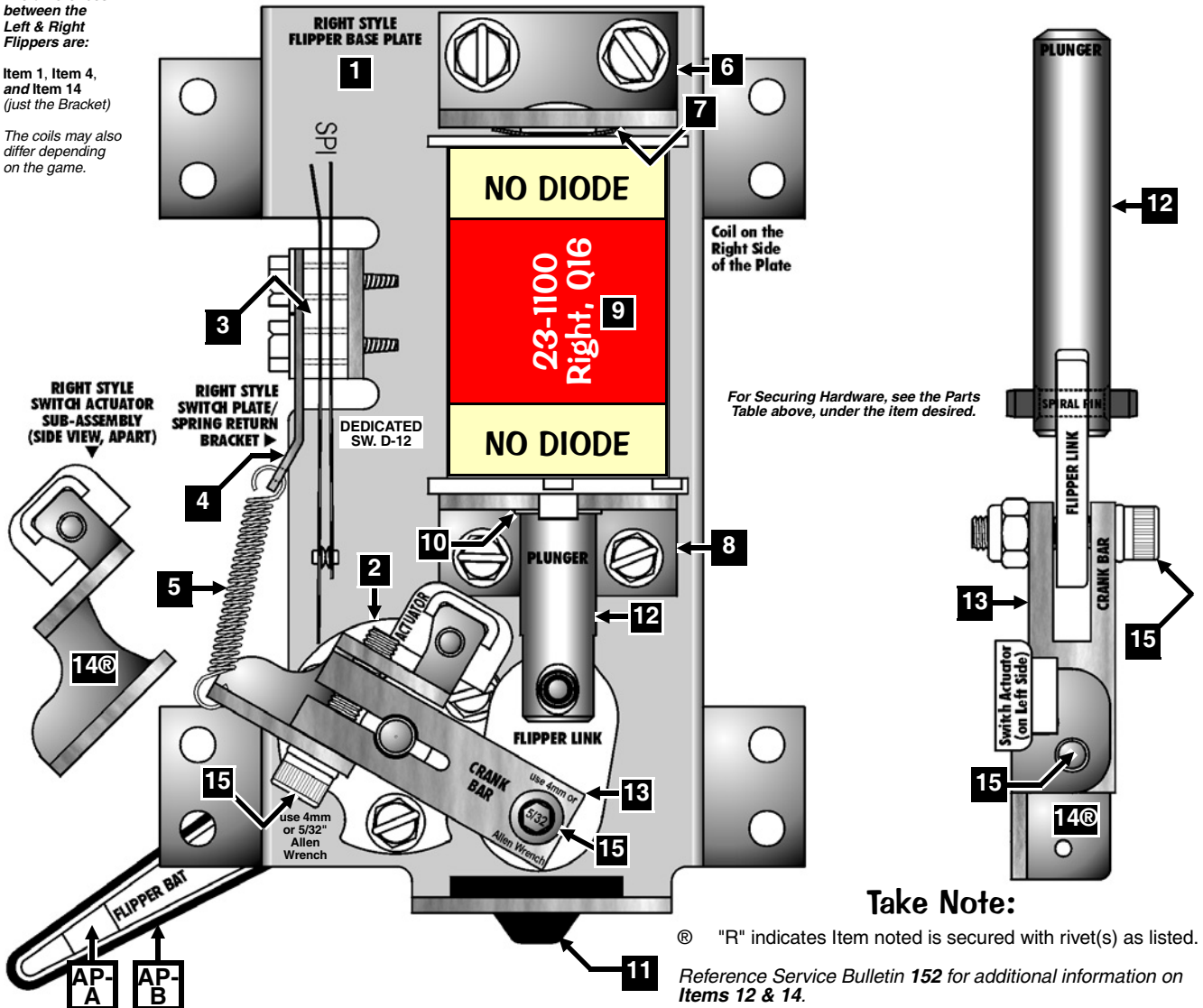

Sec. 4: Drawings ...

Flipper (Upper Left) Assembly, 500-6543-35-NDM (Items 1-15) and Assoc. Parts: Yellow Mini-Flipper Bat & Shaft Assy., 515-6275-06 (Items AP-A/-B)



Nr.	FLIPPER (LEFT) PARTS	QTY.	SPI PART Nr.	Nr.	FLIPPER (LEFT) PARTS	QTY.	SPI PART Nr.
1	Flipper Base Plate (LEFT) Modified Item 1 is secured below the playfield by: #8 X 1/2" SHWH AB (Zc.) (Qty. 8) (234-5101-00) Ordering Note: Use Item FRP1, see the end of this Parts Table.	1	See FRP1	13	Crank Bar Item 13 requires: Bushing, .192" ø ID X .312" ø OD X .195" (Qty. 1) (530-5139-00)	1	530-5070-02
2	Flipper Bat Bushing (White Plastic) .25" ø I.D. Item 2 is secured to Item 1 by: #6-32 X 3/8" HWH Swage (Ser.) Zc. (Qty. 3) (237-5976-02)	1	545-5070-00	14®	Switch Actuator (LEFT) Sub-Assy. For Individual Items use : Actuator & Spring Bracket (LEFT) (535-9038-01) and ® Switch Actuator (White Plastic) (545-5612-00) and is secured to the Bracket by: Rivet, 1/8" ø X 1/4" Lg. (Qty. 1) (249-5003-00)	1	515-7257-01
3	1/4" x 3/8" Plastic Spacer Gray Item 3 is secured to Item 1 by: #6-32 X 5/8" HWH Swage (Ser.) Zc. (Qty. 2) (237-5976-04)	2	254-5000-02	15	Set Screw: #10-32 X 3/4" Socket Hd. Item 15 requires: #10-32 Nylon Stop Nut (Qty. 1 Flipper Link Side Only) (240-5203-00) and #10 Split Lock Washer (244-5003-00) Tool Required for Item 15: 5/32" or 4mm Allen Wrench	2	237-6144-00
4	Sw. Plate/Spring Return Brkt. (LEFT)	1	535-7354-01	Flipper Rebuild Parts for Easier Installation, Save \$:			
5	Flipper Return Spring	1	265-5035-00	FRP1	Flipper Base Plate Kit (LEFT) Modified Includes Item 1 pre-threaded, with the Securing Hardware for Items 2, 3, 6 & 8.		515-6617-01-93
6	Coil Stop Bracket Sub-Assembly Item 6 is secured to Item 1 by: #10-32 X 3/8" SHWH Swage (Serr) Zinc (Qty. 2) (237-5985-00) and #10 Split Lock Washer (Qty. 2) (244-5003-00)	1	515-6308-01	FRP2	Plunger, Link & Crank (LEFT) Assy. Includes above Items 12, 13, 14 and 15 and is pre-assembled.		515-7203-01
7	Spring Washer (17/32" ID X 3/4" X 1")	1	269-5002-00	FRP3	Flipper (LEFT) Rebuild Kit Same as FRP2, but also includes above Items 6 & 10.		500-6307-10
8	Coil Support Bracket Item 8 is secured to Item 1 by: #8-32 X 3/8" HWH Swage (Ser.) Zc. (Qty. 2) (237-5975-00)	1	535-7356-00	ASSOCIATED PARTS ARE NOT INCLUDED WITH THE ABOVE ASSEMBLY.			
9	Coil, 23-1500 [NO DIODE] (Left) COIL DOES NOT REQUIRE A DIODE. SEE ☺ COIL NOTE BELOW FOR DETAILS.	1	090-5062-ND	Nr.	ASSOCIATED PART(S)	QTY.	SPI PART Nr.
10	Coil Sleeve	1	545-5388-00	AP-A	YELLOW Mini-Flipper Bat (Plain) & Shaft (Non-Knurled End) Assembly	1	515-6275-06
11	Deflector Pad (Bumper)	1	545-5428-00	AP-B	Small Flipper BLACK Rubber Ring	1	545-5207-00
12	Flipper Plunger & Link Sub-Assy. For Individual Items use : Flipper Plunger (530-5349-01) and Plunger "Flipper" Link (545-5611-01) and is secured to the Plunger by: Bushing, .16" ø ID X .281" ø OD X .187" (Qty. 1) (530-5532-00) and Spiral Pin ø 5/32" X 3/4" Lg. (Qty. 1) (251-5015-02)	1	515-6304-03				

Sec. 4: Drawings ...

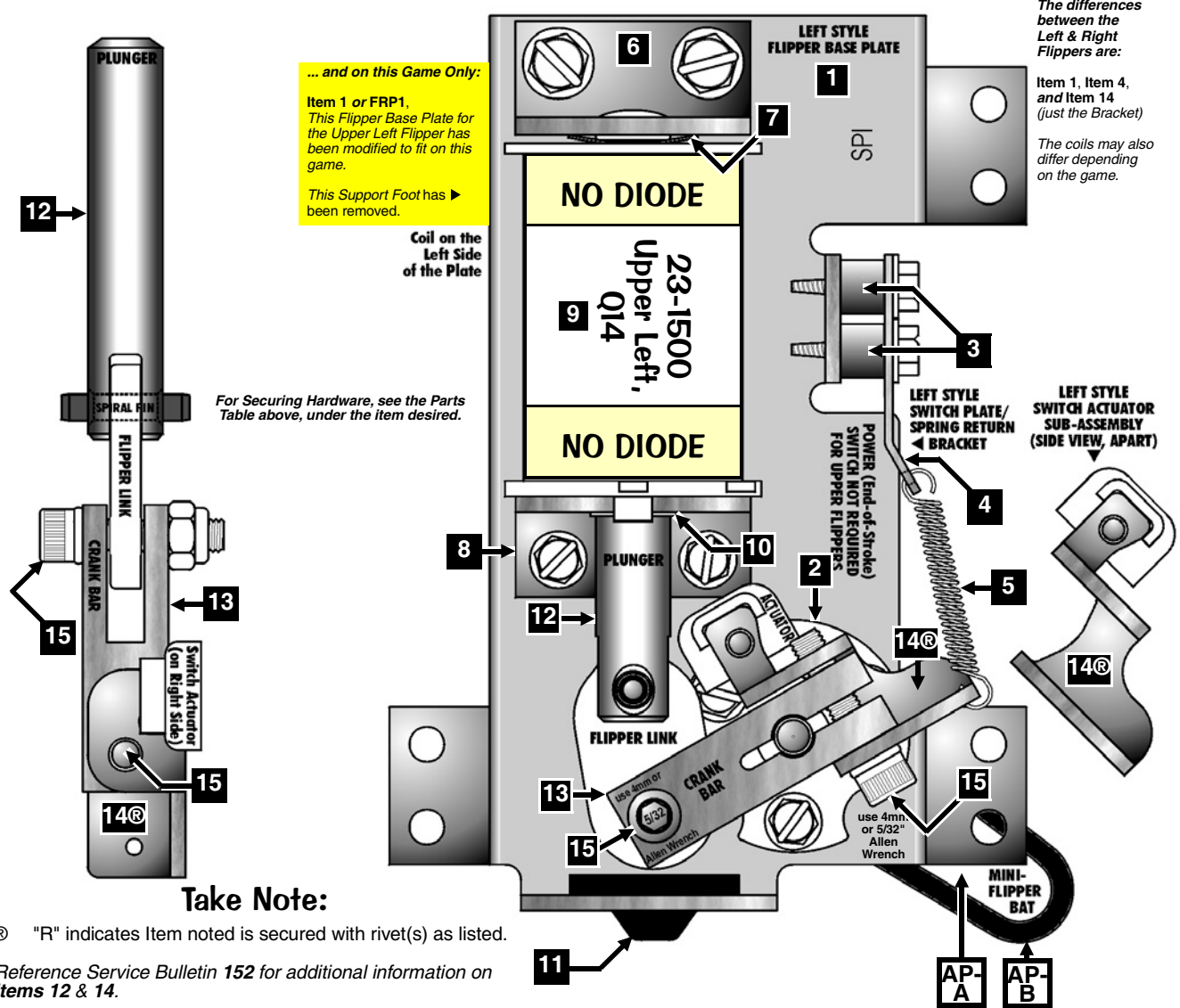

Take Note:

® "R" indicates Item noted is secured with rivet(s) as listed.

Reference Service Bulletin 152 for additional information on Items 12 & 14.

* To Order the Flipper (Left) Rebuild Kit ask for Part Nr.: 500-6307-10 (includes Items 6, 10, 12, 13, 14 & 15)



Bumper Top, Bumper Bottom & Bumper Switch Individual Parts Only (Items 1-18) and Associated Part: See Parts Table Below.

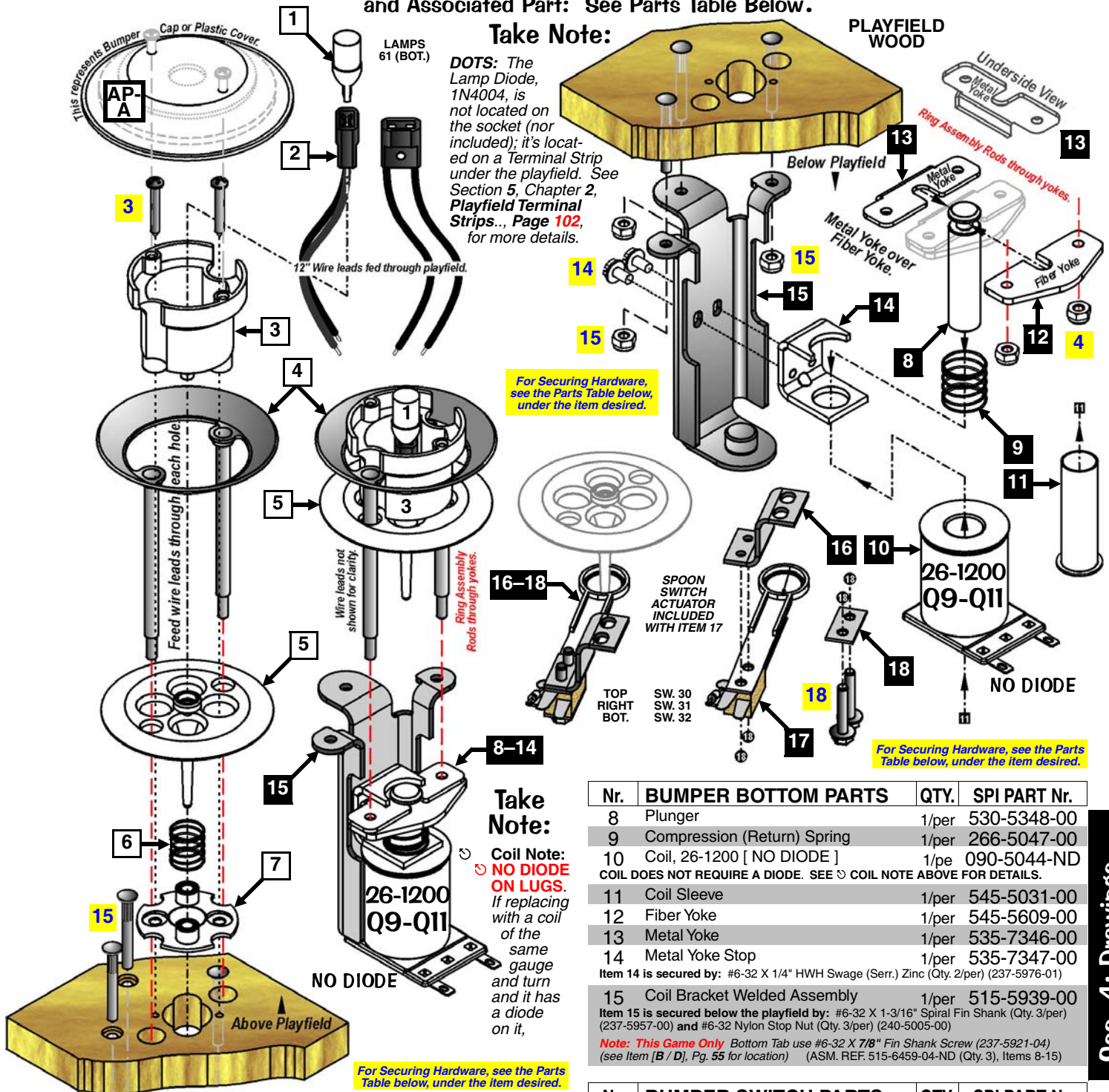

Nr.	BUMPER TOP PARTS	QTY.	SPI PART Nr.
1	LED Module (WHT) (6.3v) Wedge Base	2	112-5024-08
2	Wedge Base Socket	2	077-5206-00
3	Bumper Body	1/per	545-5197-00
Item 3 is secured above the P/F by: #5 X 7/8" PRH AB (Zinc) (Qty. 2/per) (237-5826-00)			
4	Ring Assembly	1/per	515-5085-00
Item 4 is secured by: #6-32 Nylon Stop Nut (Qty. 2/per) (240-5005-00)			
5	Bumper Skirt (Switch Actuator)	1/per	545-5607-00
6	Bumper Skirt Compression Spring	1/per	266-5048-00
7	Bumper Base	1/per	545-5195-00
(ASM. REF. 515-6459-01L (Qty. 2), Items 1-7; 515-6459-00 (Qty. 1), Items 3-7)			

The Top & Bottom Assemblies are secured together by hardware noted in Item 4.

Nr.	BUMPER BOTTOM PARTS	QTY.	SPI PART Nr.
8	Plunger	1/per	530-5348-00
9	Compression (Return) Spring	1/per	266-5047-00
10	Coil, 26-1200 [NO DIODE]	1/pe	090-5044-ND
COIL DOES NOT REQUIRE A DIODE. SEE COIL NOTE ABOVE FOR DETAILS.			
11	Coil Sleeve	1/per	545-5031-00
12	Fiber Yoke	1/per	545-5609-00
13	Metal Yoke	1/per	535-7346-00
14	Metal Yoke Stop	1/per	535-7347-00
Item 14 is secured by: #6-32 X 1/4" HWH Swage (Serr.) Zinc (Qty. 2/per) (237-5976-01)			
15	Coil Bracket Welded Assembly	1/per	515-5939-00
Item 15 is secured below the playfield by: #6-32 X 1-3/16" Spiral Fin Shank (Qty. 3/per) (237-5957-00) and #6-32 Nylon Stop Nut (Qty. 3/per) (240-5005-00)			
Note: This Game Only Bottom Tab use #6-32 X 7/8" Fin Shank Screw (237-5921-04) (See Item [B / D], Pg. 55 for location) (ASM. REF. 515-6459-04-ND (Qty. 3), Items 8-15)			

Nr.	BUMPER SWITCH PARTS	QTY.	SPI PART Nr.
16	Switch Bracket	1/per	535-7342-00
Item 16 is secured by: #8 X 1/2" HWH AB (Zinc) (Qty. 2/per) (234-5101-00)			
17	Bumper Stack (Blade) Switch Assy.	1/per	180-5015-04
Included with Item 17: Spoon Switch Actuator (545-5610-02). Switch has a Diode (1N4004) (112-5003-00). Can be replaced with (1N4001) (112-5001-00).			
18	Switch Body Protect Plate	1/per	535-7344-00
Items 17 & 18 are secured by: #6-32 X 3/4" HWH Swage (Serr.) Zc. (Qty. 2) (237-5976-05) (ASM. REF. 515-6459-09 (Qty. 3), Items 16-18)			

ASSOCIATED PARTS ARE NOT INCLUDED WITH THE ABOVE ASSEMBLIES.

Nr.	ASSOCIATED PART(S)	QTY.	SPI PART Nr.
AP-A	Bumper [Pop] Cap (Multi-Colors)	2	550-5057-XX
Replace -XX in the part number with -04 (Green); -06 (Yellow) Location: Page 48			
Item AP-A is secured by: #4 X 3/4" PRH (Zinc) T-25 (Qty. 2/per) (237-5873-00)			

Sec. 4: Drawings ...



Slingshot (Left & Right) Assemblies, 500-5849-02-ND (Qty. 2) (Items 1-9)

Nr.	SLINGSHOT PARTS	QTY.	SPI PART Nr.	Nr.	SLINGSHOT PARTS	QTY.	SPI PART Nr.
1	Slingshot Bracket Assembly Item 1 is secured below the playfield by: #8 X 1/2" SHWH AB (Zc.) (Qty. 3) (234-5101-00)	1/per	515-5339-01	6	Compression (Return) Spring	1/per	266-5020-00
2	Coil Retaining Bracket Item 2 is secured to Item 1 by: #8-32 X 3/8" PPH MS (Sems) (Qty. 2) (232-5301-00)	1/per	535-5203-03	7	Slingshot Stack (Blade) Switch Only 1 of the 2 Switches has a Diode (1N4004) (112-5003-00). See Note Below on Drawing. Can be replaced with (1N4001) (112-5001-00).	2/per	180-5054-00
3	Coil, 27-1500 [NO DIODE] COIL DOES NOT REQUIRE A DIODE. SEE ☺ COIL NOTE BELOW FOR DETAILS.	1/per	090-5004-ND	8	Switch Body Protect Plate Items 7 & 8 are secured to Item 1 by: #6-32 X 5/8" HWH Swage (Qty. 4) (237-5976-04)	2/per	535-5045-00
4	Coil Sleeve	1/per	545-5031-00	9®	Riveted Arm & Tip Assembly For Individual Parts use (requires drilling out rivet & re-venting): Arm (515-5341-01), Kicker Tip (545-5216-01) and Rivet, 1/8" ø x 1/4" Lg. (249-5003-00) The Riv. Arm is secured to Item 1 by: Retaining Ring, 1/4" ø Shaft (Qty. 1) (270-5002-00) Ordering Note: If 515-5340-01 is unavailable, order the individual part(s) actually required.	1/per	515-5340-01
5	Plunger & Link Assembly For Individual Items use: Plunger 2" Lg. (530-5025-01), Plunger Link (545-5293-00) and Roll Pin 1/8" ø x 5/8" Lg. (251-5008-00) The Plunger Link is secured to the Riveted Arm by: Retaining Ring, 1/4" ø Shaft (Qty. 1) (270-5002-00) Ordering Note: If 515-5338-00 is unavailable, order the individual part(s) actually required.	1/per	515-5338-00				

Take Note:

- ☺ **Coil Note:** ☺ **NO DIODE ON LUGS.** If replacing with a coil of the same gauge and turn and it has a diode on it, remove it before using.
- ® "R" indicates Item noted is secured with rivet(s) as listed.

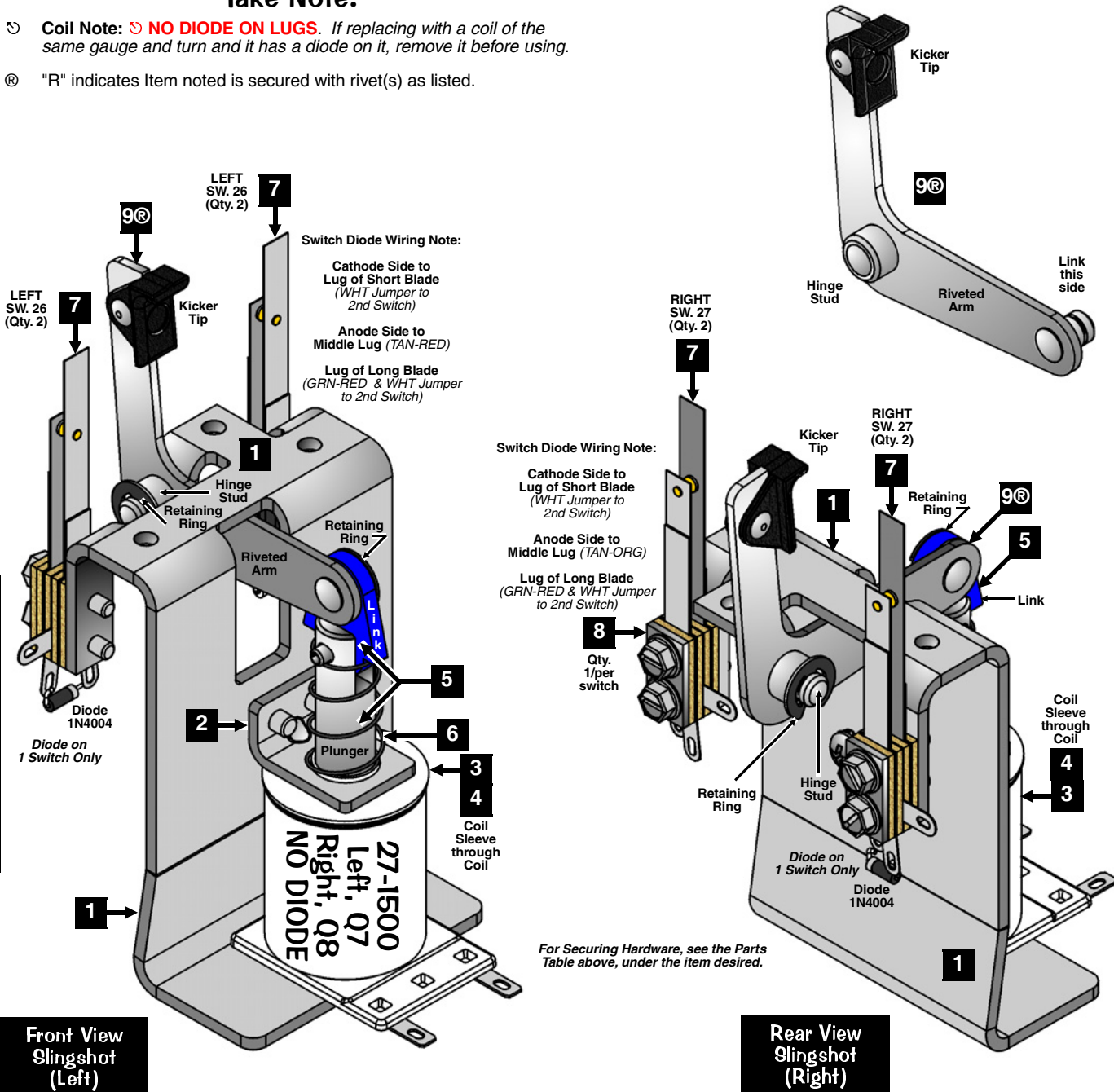

Up/Down Post (Center Drain) Assembly, 500-7022-00 (Items 1-14)

When energized, the Up/Down Post prevents the ball from draining between the lower flippers.

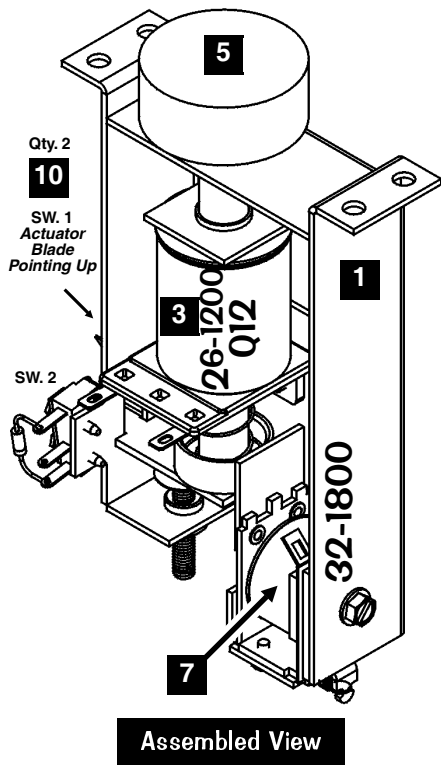

Assembled View

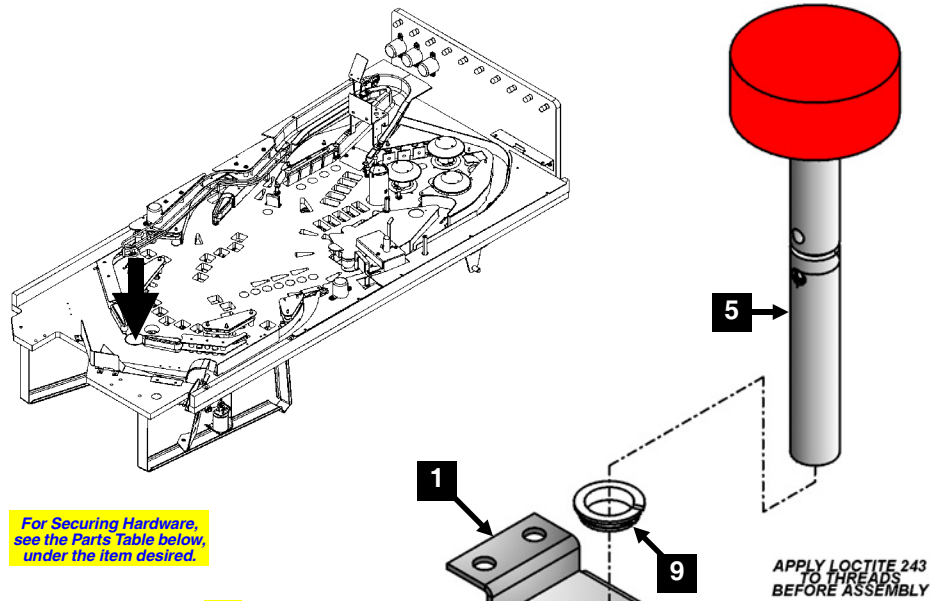

Take Note:

☉ **Coil Note:** ☉ **NO DIODE ON LUGS.** If replacing with a coil of the same gauge and turn and it has a diode on it, remove it before using.

Nr.	UP/DOWN POST PARTS	QTY.	SPI PART Nr.
1	Bracket, Coil Mounting	1	535-9883-00
Item 1 is secured below the playfield by: #10 X 1/2" HWH A (Zinc) (Qty. 4) (237-5817-00)			
2	Coil Retaining Bracket	1	535-5203-03
Item 2 is secured by: #8-32 X 1/4" SHWH Swage Ser. (Zinc) Wax (Qty. 2) (237-5975-04)			
3	Coil, 26-1200 [NO DIODE]	1	090-5044-ND
COIL DOES NOT REQUIRE A DIODE. SEE ☉ COIL NOTE ABOVE FOR DETAILS.			
4	Coil Sleeve (Formost #10-7077)	1	545-5076-01
5	Up/Down Post Shaft + Bumper Asm.	1	511-5001-00
For Individual Items use : Up/Down Post Shaft Sub-Asm. (515-7597-00), Retaining Ring, 1/4" ø (270-5002-00) and Bumper (Red Plastic) (550-5029-02)			
6	Plunger Head	1	530-5511-00
Item 6 is secured by: #18-8 SS S/Pin 92373A143 3/32" X 1/2" (Qty. 1) (251-5002-00)			
7	Mini-Coil, Latch & Frame Assembly	1	515-7595-00-ND
For Individual Items use : Coil, 32-1800 [No Diode] (090-5031-00-ND), Spring Ramp Lock Up SPR29-12 (265-5024-00), Latch-Armature Assembly (515-7596-00) and Trip Coil Frame (535-6198-00)			
Item 7 is secured by: #10 X 1/2" PPH MS (Zinc) (Qty. 1) (237-5702-00)			
8	Spring Washer [17/32" ID X 7/8" X 1/64"]	1	269-5002-00
9	Nyliner [7/16" Shaft, 7L1-FF]	1	545-5418-00
10	Switch, 1-1/4" Actuator	2	180-5010-04
Switch has a Diode (1N4004) (112-5003-00). Can be replaced with (1N4001) (112-5001-00).			
11	Bracket (Flag), Switch Mounting	1	535-9885-00
Item 11 is secured by: #8-32 X 3/8" SHWH Swage Ser. (Zinc) Wax (Qty. 1) (237-5975-00)			
12	Switch Body Protect Plate	2	535-6539-00
Item 12 is secured to Items 10-11 by: #2-56 X 1/2" Unslotted Ser. HWH #4 Head TR3 Black (Qty. 2) (237-5937-02)			
13	Compression (Relay) Spring	1	266-5020-00
14	#10-32 Adj. Spindle Stop w/Rubber Tip	1	280-5014-00
Item 14 is secured by: #10-32 Keps Nut (Qty. 1) (240-5208-00)			

Ordering Note: If 500-7022-00 is unavailable, order the individual part(s) actually required (for cable wiring (036-5523-14-93) to be included with 500-7022-00 Asm., add -93 to Part #).

Sec. 4: Drawings ...



Scoop & Vertical Up-Kicker (VUK) Assembly, 500-7028-00 (Items 1-10)

When the ball enters the scoop, the VUK is energized and ejects the ball out.

Take Note:

DOTS: The Switch Diode, 1N4004, is not located on either VUK Assembly (nor included); it's located on a Terminal Strip under the playfield near this assembly. See Section 5, Chapter 2, **Playfield Terminal Strips...**, Page 102, for more details.

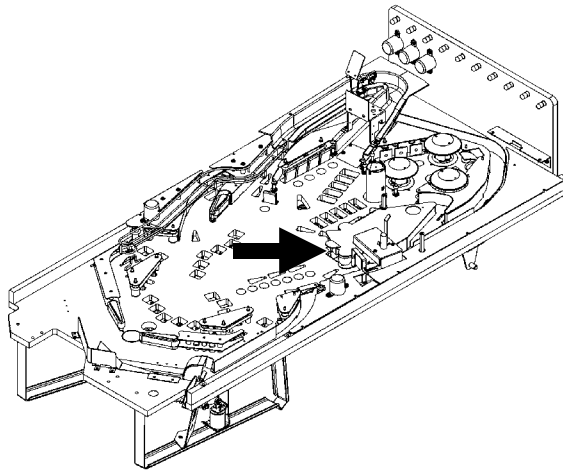

For Securing Hardware, see the Parts Table below, under the item desired.

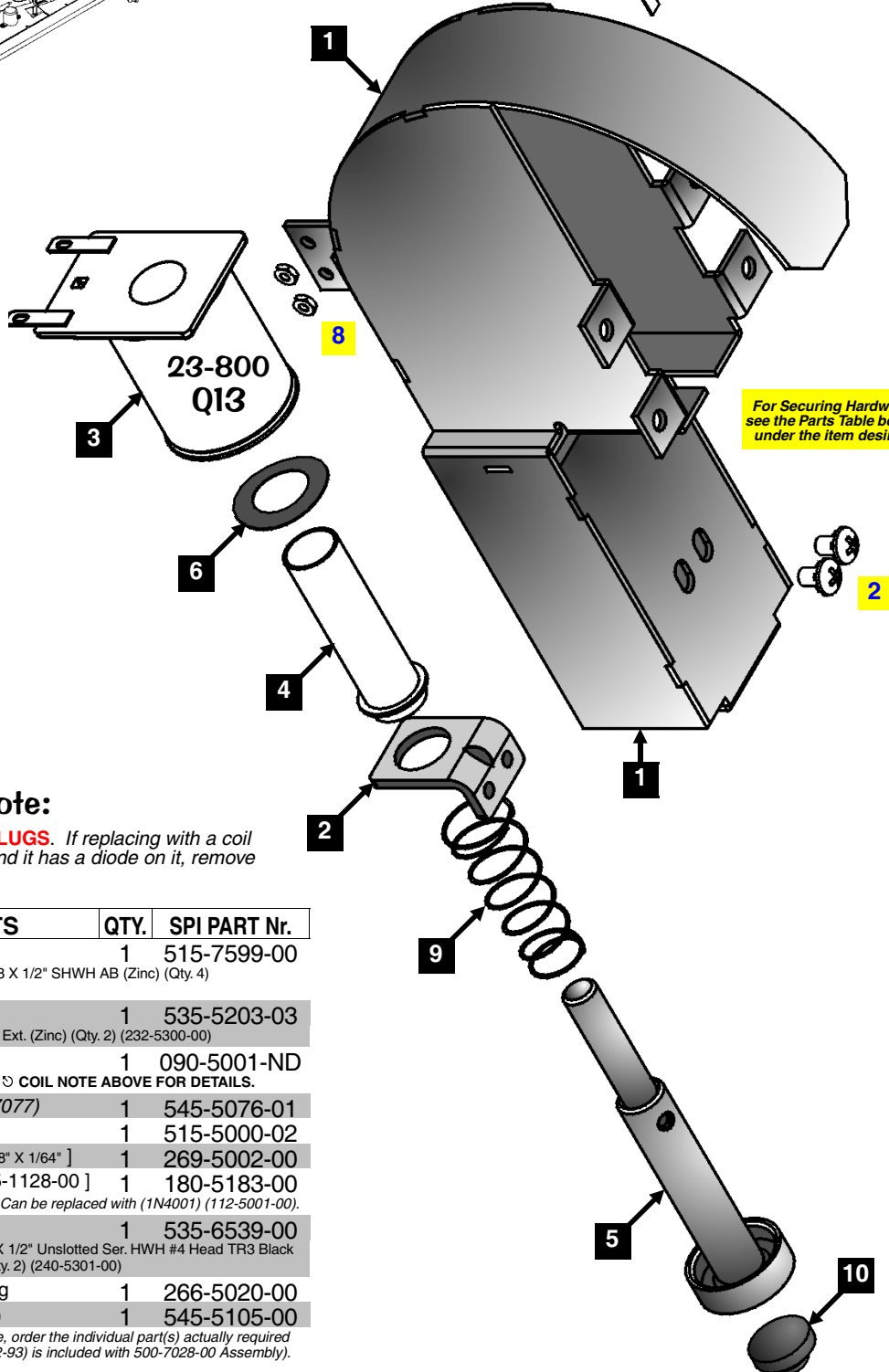
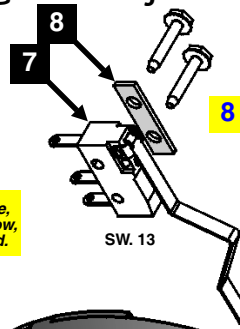

For Securing Hardware, see the Parts Table below, under the item desired.

Take Note:

☹ **Coil Note:** ☹ **NO DIODE ON LUGS.** If replacing with a coil of the same gauge and turn and it has a diode on it, remove it before using.

Sec. 4: Drawings ...

Nr.	SCOOP & VUK PARTS	QTY.	SPI PART Nr.
1	Bracket, Scoop Weldment	1	515-7599-00
Item 1 is secured below the playfield by: #8 X 1/2" SHWH AB (Zinc) (Qty. 4) (234-5101-00)			
2	Coil Retaining Bracket	1	535-5203-03
Item 2 is secured by: #8-32 X 1/4" PPH MS Ext. (Zinc) (Qty. 2) (232-5300-00)			
3	Coil, 23-800 [NO DIODE]	1	090-5001-ND
COIL DOES NOT REQUIRE A DIODE. SEE ☹ COIL NOTE ABOVE FOR DETAILS.			
4	Coil Sleeve (Formost #10-7077)	1	545-5076-01
5	Plunger Assembly	1	515-5000-02
6	Spring Washer [17/32" ID X 7/8" X 1/64"]	1	269-5002-00
7	Switch (Scoop), [Happ #95-1128-00]	1	180-5183-00
Switch has a Diode (1N4004) (112-5003-00). Can be replaced with (1N4001) (112-5001-00).			
8	Switch Body Protect Plate	1	535-6539-00
Item 8 is secured to Items 1 & 7 by: #2-56 X 1/2" Unslotted Ser. HWH #4 Head TR3 Black (Qty. 2) (237-5937-02) and #2-56 Hex Nut (Qty. 2) (240-5301-00)			
9	Compression (Relay) Spring	1	266-5020-00
10	Rubber Bumper (Grommet)	1	545-5105-00

Ordering Note: If 500-7028-00 is unavailable, order the individual part(s) actually required (cable wiring (036-5523-13-93 & 036-5523-12-93) is included with 500-7028-00 Assembly).



Eject / Vertical Up-Kicker (VUK) Assembly, 500-6846-01 (Items 1-10)

When the ball enters the eject hole, the VUK is energized and ejects the ball out.

Take Note:

DOTS: The Switch Diode, 1N4004, is not located on either VUK Assembly (nor included); it's located on a Terminal Strip under the playfield near this assembly. See Section 5, Chapter 2, **Playfield Terminal Strips..**, Page 102, for more details.

For Securing Hardware, see the Parts Table below, under the item desired.

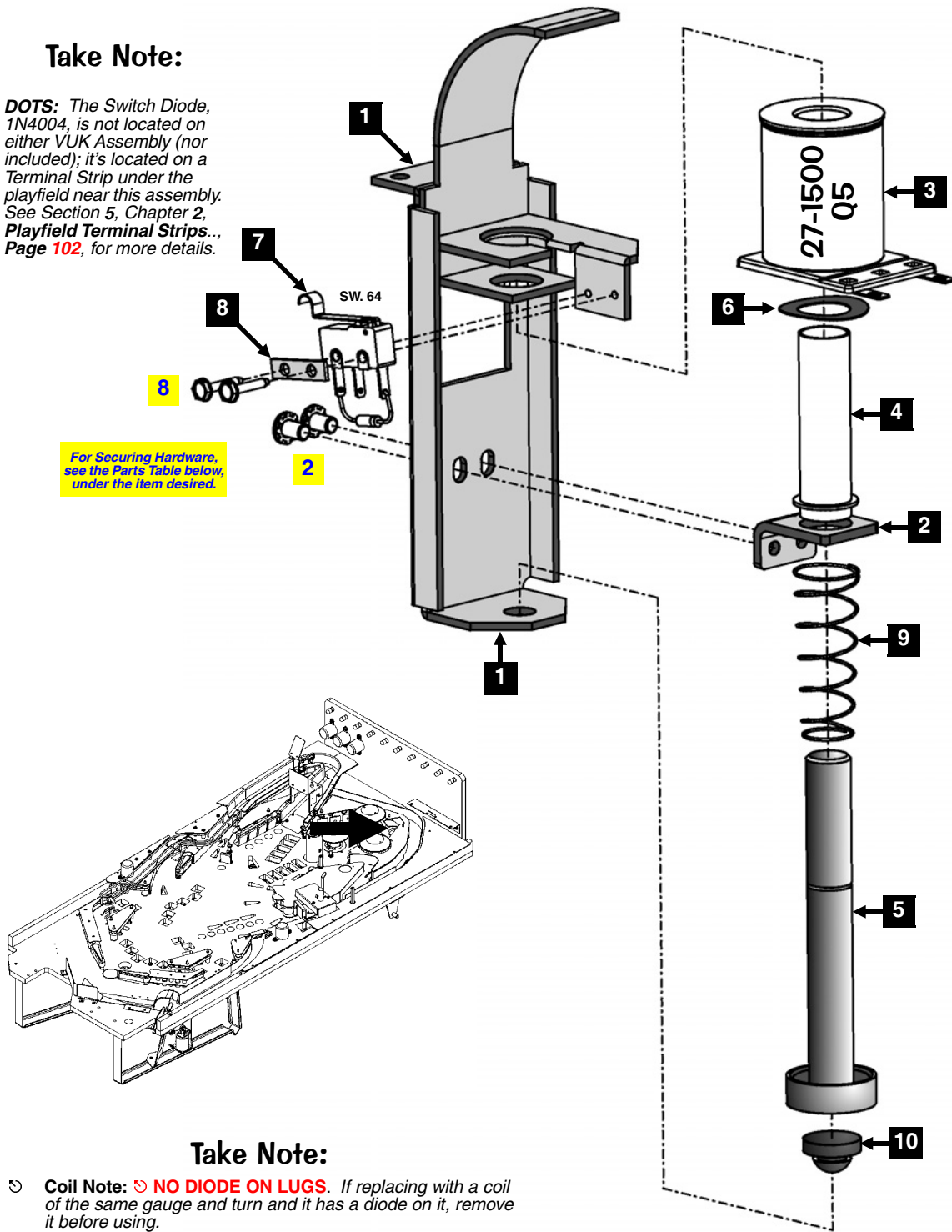

Take Note:

☺ **Coil Note:** ☹ **NO DIODE ON LUGS.** If replacing with a coil of the same gauge and turn and it has a diode on it, remove it before using.

Nr.	SCOOP & VUK PARTS	QTY.	SPI PART Nr.	Nr.	SCOOP & VUK PARTS	QTY.	SPI PART Nr.
1	Bracket, Eject VUK Housing	1	535-9637-01	7	Switch, Actuator Simulated Roller	1	180-5209-00
Item 1 is secured below the playfield by: #8 X 5/8" PPH AB (Zinc) (Qty. 3) (232-5101-00)				Switch [Omron 100MA SS01GL1373FT] has a Diode (1N4004) (112-5003-00). Can be replaced with (1N4001) (112-5001-00).			
2	Coil Retaining Bracket	1	535-5203-03	8	Switch Body Protect Plate	1	535-6539-00
Item 2 is secured by: #8-32 X 1/4" PPH MS Ext. (Zinc) (Qty. 2) (232-5300-00)				Item 8 is secured to Items 1 & 7 by: #2-56 X 1/2" Unslotted Ser. HWH #4 Head TR3 Black (Qty. 2) (237-5937-02)			
3	Coil, 27-1500 [NO DIODE]	1	090-5004-ND	9	Compression (Relay) Spring	1	266-5020-00
COIL DOES NOT REQUIRE A DIODE. SEE ☺ COIL NOTE ABOVE FOR DETAILS.				Item 9 is secured to Item 5 by: #2-56 X 1/2" Unslotted Ser. HWH #4 Head TR3 Black (Qty. 2) (237-5937-02)			
4	Coil Sleeve (Formost #10-7077)	1	545-5076-01	10	Rubber Bumper (Grommet)	1	545-5105-00
5	Steel & Nylon Plunger Assembly	1	515-5941-01	Ordering Note: If 500-6846-01 is unavailable, order the individual part(s) actually required (for cable wiring (036-5523-09-93) to be included with 500-6846-01 Asm., add -93 to Part #).			
6	Spring Washer [17/32" ID X 7/8" X 1/64"]	1	269-5002-00				

1-Bank Drop Target Assembly, 500-7029-01 (Items 1-14)

[Different Views & Parts Table on the next page.]

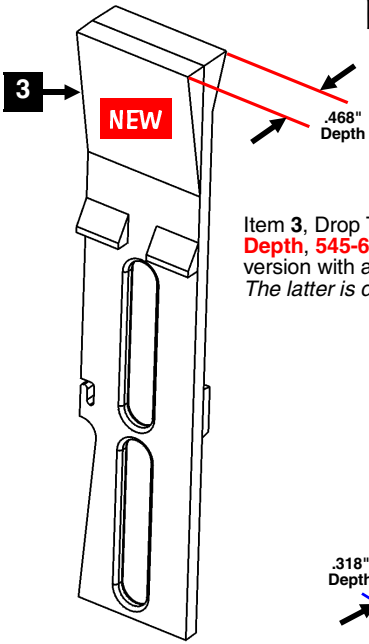

Front View

Drop Target Note:

Item 3, Drop Target (Black Plastic) Rollover with a **.468" Depth**, 545-6305-00 can be substituted with the previous version with a **.318" Depth**, 545-6162-00. The latter is depicted in the assembly drawings.

Take Note:

Coil Note: **NO DIODE ON LUGS**. If replacing with a coil of the same gauge and turn and it has a diode on it, remove it before using.

Coil Side Exploded View

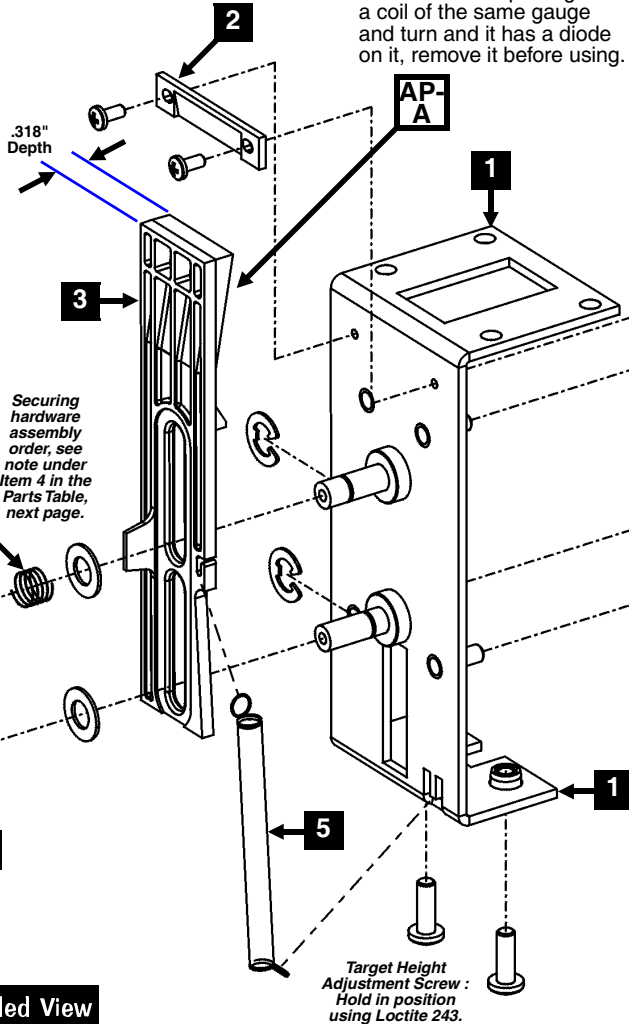
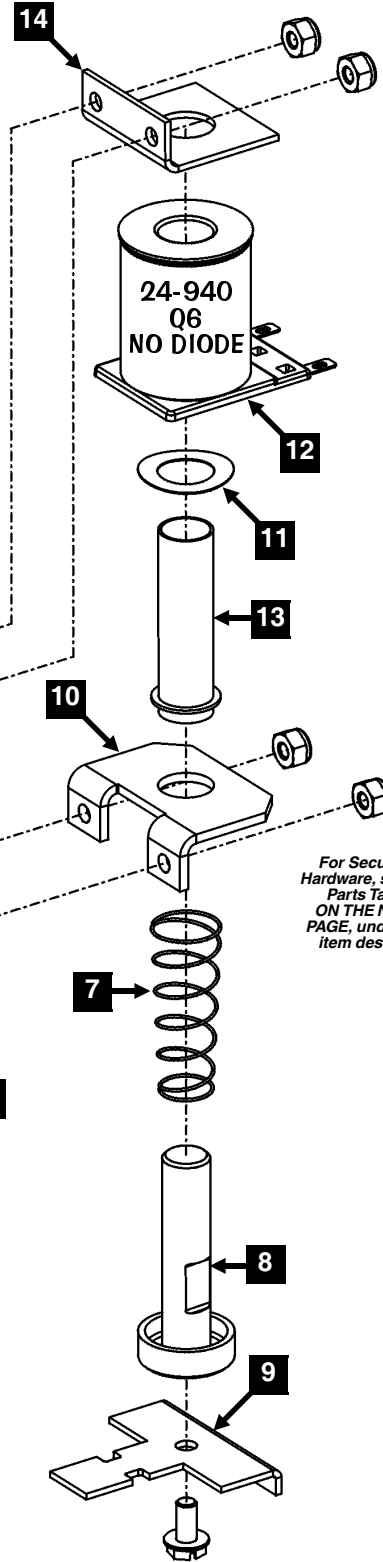

TARGET/PCB Side Exploded View

Securing hardware assembly order, see note under Item 4 in the Parts Table, next page.

For Securing Hardware, see the Parts Table ON THE NEXT PAGE, under the item desired.

Target Height Adjustment Screw : Hold in position using Loctite 243.

For Securing Hardware, see the Parts Table ON THE NEXT PAGE, under the item desired.

Sec. 4: Drawings ...



1-Bank Drop Target Assembly, 500-7029-01 (Items 1-14) Continued and Associated Part : See Parts Table Below [Different Views on the previous page.]

ASSOCIATED PARTS ARE NOT INCLUDED WITH THE ABOVE ASSEMBLY.

Nr.	1-BANK DROP TRGT. PARTS	QTY.	SPI PART Nr.	Nr.	ASSOCIATED PART(S)	QTY.	SPI PART Nr.
1	Frame & Pem Weldment, 1-Bank D/T	1	515-7604-01	AP-A	Kit: Decals (incl. -26 Drop Target)	1	802-5000-A5
Item 1 is secured under the playfield by: #8 X 1/2" SHWH AB (Zc.) (Qty. 4) (234-5101-00)							
2	Target Rest Ledge (Blk.), 1-Bank D/T	1	545-6163-01				
Item 2 is secured to Item 1 by: #4-40 X 1/4" PPH MS (Zinc) (Qty. 2) (237-6169-00)							
3	Drop Target (Black Plastic) Rollover	1	545-6305-00				
4	Compression (Short) Spring	1	266-5089-00				
Items 3 & 4 are secured to Item 1 @ top by: Washer, 1/2" X 17/64" X .03" (Qty. 2) (242-5091-00) and Retaining Ring, 1/4" ø (Qty. 1) (270-5002-00)							
FRAME PEM → WASHER → SPRING → WASHER → RETAINING RING → OPTO PCB → SCREW							
Item 3 is secured to Item 1 @ bottom by: Washer, 1/2" X 17/64" X .03" (Qty. 1) (242-5091-00) and Retaining Ring, 1/4" ø (Qty. 1) (270-5002-00)							
5	Reset (Long) Spring (Red Dipped)	1	265-5003-02				
6	PCB, Slotted OPTO X1	1	520-5252-01				
Item 6 is secured to Item 1 by: #6-32 X 3/8" PPH MS (Zinc) (Qty. 2) (237-5501-00)							
7	Compression (Return) Spring	1	266-5020-00				
8	Steel Plunger with End Cap	1	530-5757-00				
9	Bracket, Target Lift (1-Bank)	1	535-9760-01A				
Item 9 is secured to Item 8 Plunger by: #10-32 X 3/8" SHWH Swage (Zinc) Wax (Qty. 1) (237-5985-00) TARGET HEIGHT ADJUSTMENT: TARGET HEIGHT IS ADJUSTED THROUGH ITEM 1 BY: #8-32 X 1/2" PPH MS (Zinc) (Qty. 2) (237-5602-00)							
10	Coil Mounting Bracket [1-Bank Style]	1	535-9777-01				
Item 10 is secured to Item 1 by: #8-32 Nylon Stop Nut (Qty. 2) (240-5102-00)							
11	Spring Washer (17/32" ID X 3/4" X 1")	1	269-5002-00				
12	Coil, 24-940 [NO DIODE]	1	090-5036-ND				
COIL DOES NOT REQUIRE A DIODE. SEE COIL NOTE ABOVE FOR DETAILS.							
13	Coil Sleeve (Formost #10-7077)	1	545-5076-01				
14	Bracket, Plunger Stop	1	535-9959-00				
Item 14 is secured to Item 1 by: #8-32 Nylon Stop Nut (Qty. 2) (240-5102-00)							

Ordering Note: If 500-7029-01 is unavailable, order the individual part(s) actually required for cable wiring, use Part Number 036-5523-15-93).

Coil Side Assembled View

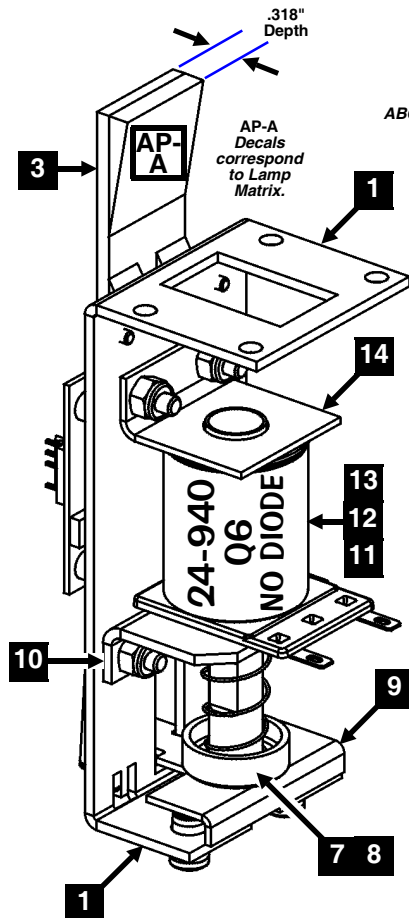

For Securing Hardware, see the Parts Table ABOVE, under the item desired.

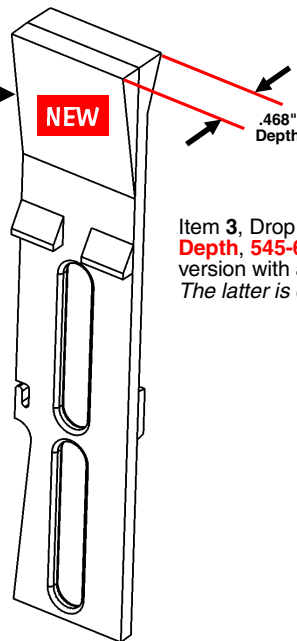

Front View

Take Note:

Coil Note: NO DIODE ON LUGS. If replacing with a coil of the same gauge and turn and it has a diode on it, remove it before using.

TARGET/PCB Side Asm'd View

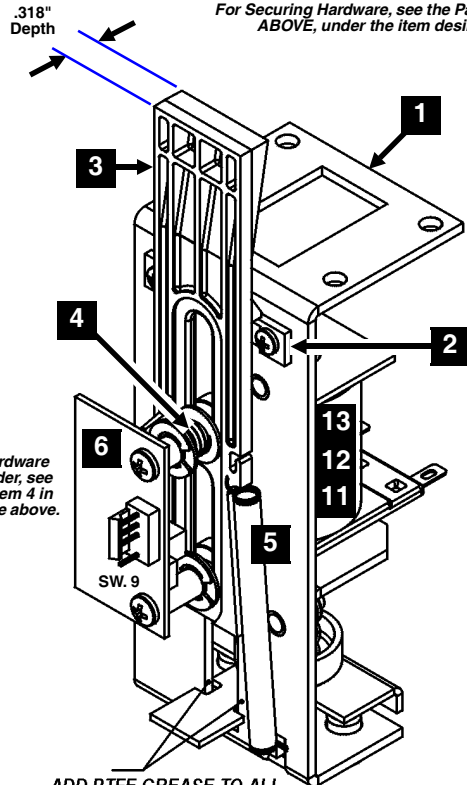

For Securing Hardware, see the Parts Table ABOVE, under the item desired.

Securing hardware assembly order, see note under Item 4 in the Parts Table above.

ADD PTFE GREASE TO ALL CONTACT AREAS AROUND SLOT P/N 000-0646-00 MAGNALUBE-G OR EQUIVALENT

Drop Target Note:

Item 3, Drop Target (Black Plastic) Rollover with a .468" Depth, 545-6305-00 can be substituted with the previous version with a .318" Depth, 545-6162-00. The latter is depicted in the assembly drawings.

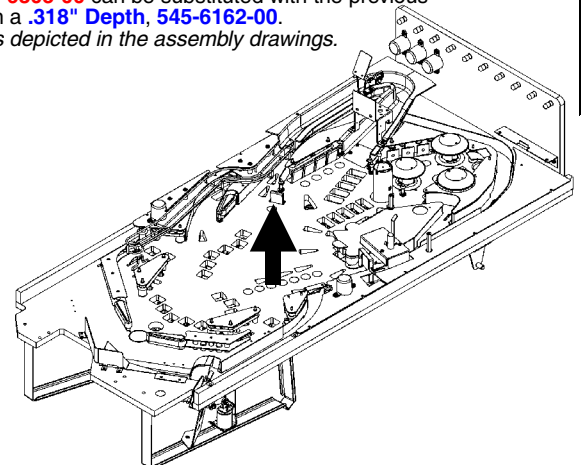

4-Bank Drop Target Assembly, 500-7029-04 (Items 1-14)

[Different Views & Parts Table on the next page.]

Coil Side Exploded View

Take Note:

Coil Note: **NO DIODE ON LUGS.**
 If replacing with a coil of the same gauge and turn and it has a diode on it, remove it before using.

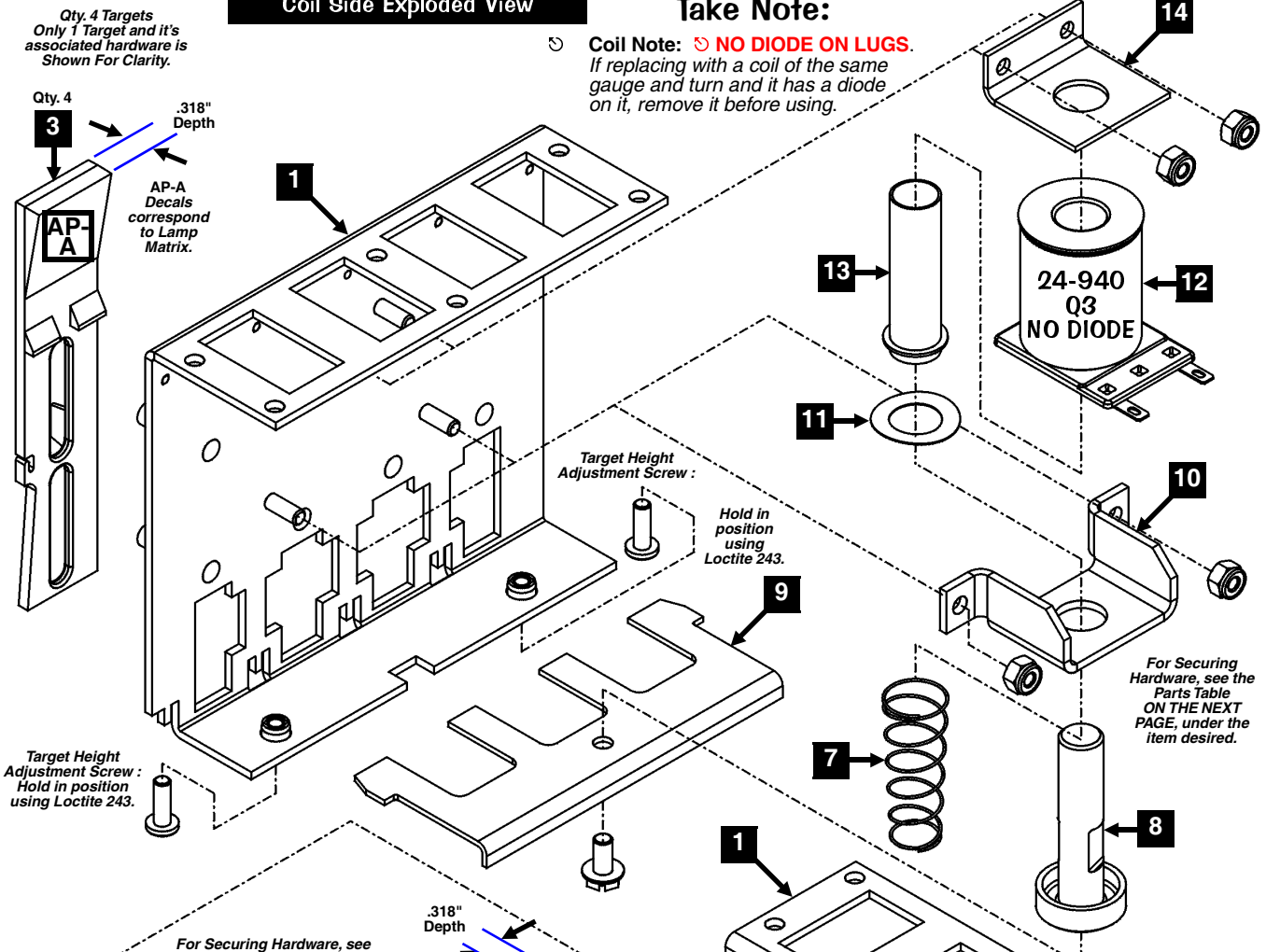

Sec. 4: Drawings ...

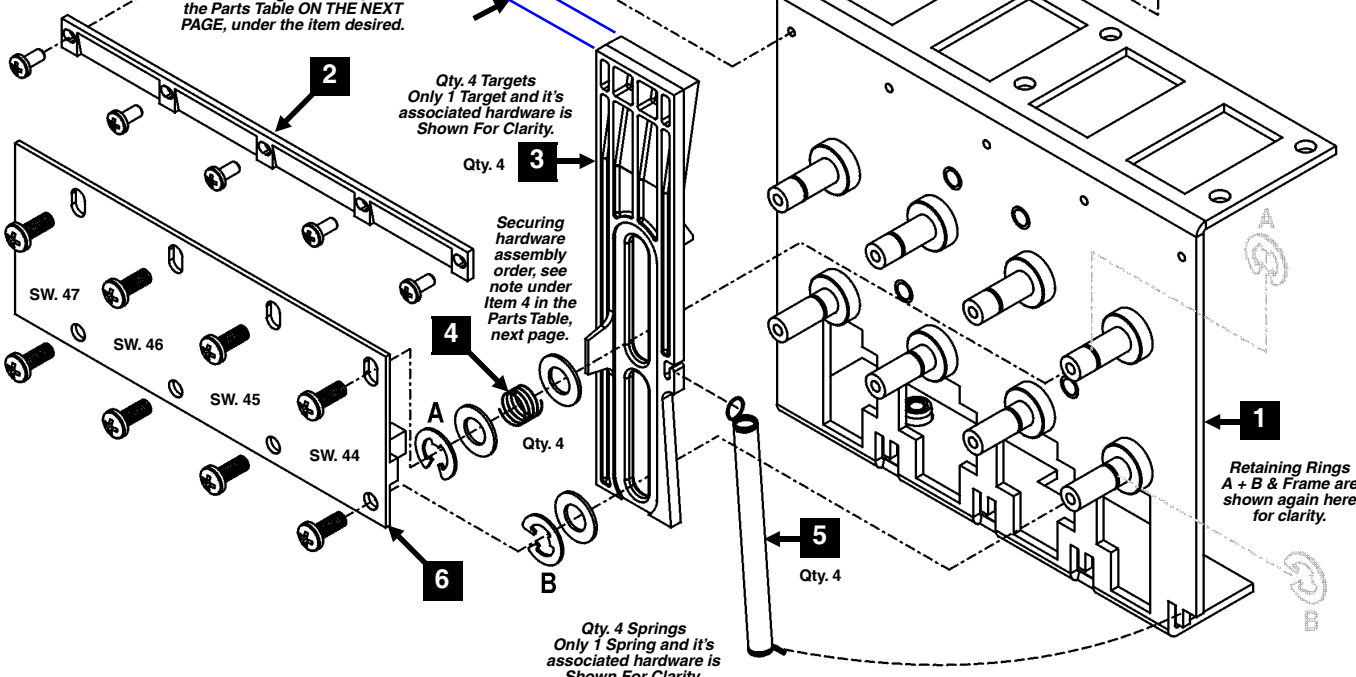

TARGET/PCB Side Exploded View



4-Bank Drop Target Assembly, 500-7029-04 (Items 1-14) Continued and Associated Part: See Parts Table Below [Different Views on the previous page.]

ASSOCIATED PARTS ARE NOT INCLUDED WITH THE ABOVE ASSEMBLY.

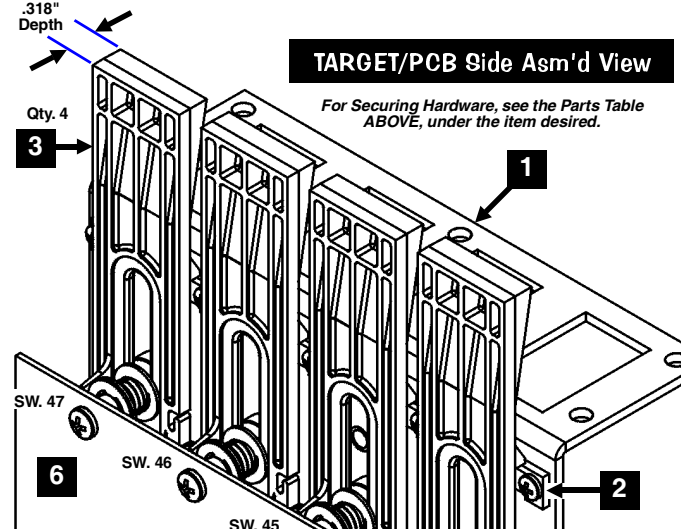
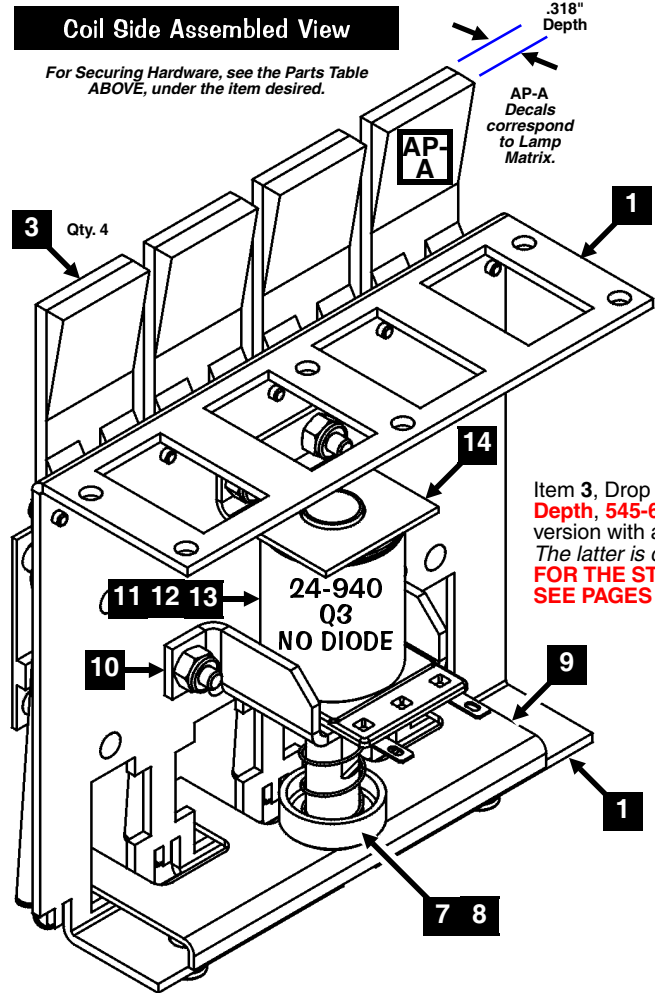
Nr.	4-BANK DROP TRGT. PARTS	QTY.	SPI PART Nr.	Nr.	ASSOCIATED PART(S)	QTY.	SPI PART Nr.
1	Frame & Pem Weldment, 4-Bank D/T	1	515-7604-04	AP-A	Kit: Decals (incl. -22--25 Drop Trgt.)	1	802-5000-A5
Item 1 is secured under the playfield by: #8 X 1/2" SHWH AB (Zc.) (Qty. 5) (234-5101-00)							
2	Target Rest Ledge (Blk.), 4-Bank D/T	1	545-6163-04	<i>Note: Individual Decals (820-6412-XX) are not available individually, ordering of kit is required.</i>			
Item 2 is secured to Item 1 by: #4-40 X 1/4" PPH MS (Zinc) (Qty. 6) (237-6169-00)							
3	Drop Target (Black Plastic) Rollover	4	545-6305-00	Take Note:			
4	Compression (Short) Spring	4	266-5089-00	☞ Coil Note: ☞ NO DIODE ON LUGS. If replacing with a coil of the same gauge and turn and it has a diode on it, remove it before using.			
Items 3 & 4 are secured to Item 1 @ top by: Washer, 1/2" X 17/64" X .03" (Qty. 2/per) (242-5091-00) and Retaining Ring, 1/4" ø (Qty. 4) (270-5002-00)							
FRAME PEM → WASHER → SPRING → WASHER → RETAINING RING → OPTO PCB → SCREW							
Item 3 is secured to Item 1 @ bottom by: Washer, 1/2" X 17/64" X .03" (Qty. 4) (242-5091-00) and Retaining Ring, 1/4" ø (Qty. 4) (270-5002-00)							
5	Reset (Long) Spring (Red Dipped)	4	265-5003-02	TARGET/PCB Side Asm'd View			
6	PCB, Slotted OPTO X4	1	520-5252-04	For Securing Hardware, see the Parts Table ABOVE, under the item desired.			
Item 6 is secured to Item 1 by: #6-32 X 3/8" PPH MS (Zinc) (Qty. 9) (237-5501-00)							
7	Compression (Return) Spring	1	266-5020-00				
8	Steel Plunger with End Cap	1	530-5757-00	Securing hardware assembly order, see note under Item 4 in the Parts Table above.			
9	Bracket, Target Lift (4-Bank)	1	535-9996-04	ADD PTFE GREASE TO ALL CONTACT AREAS AROUND SLOT P/N 000-0646-00 MAGNALUBE-G OR EQUIVALENT			
Item 9 is secured to Item 8 Plunger by: #10-32 X 3/8" SHWH Swage (Zinc) Wax (Qty. 1) (237-5985-00) TARGET HEIGHT ADJUSTMENT: TARGET HEIGHT ADJUSTMENT: TARGET HEIGHT ADJUSTMENT:							
Item 9 is adjusted through Item 1 by: #8-32 X 1/2" PPH MS (Zinc) (Qty. 2) (237-5602-00)							
10	Coil Mounting Bracket [+2 Bank Style]	1	535-9995-01	Coil Side Assembled View			
Item 10 is secured to Item 1 by: #8-32 Nylon Stop Nut (Qty. 2) (240-5102-00)							
11	Spring Washer (17/32" ID X 3/4" X 1")	1	269-5002-00	For Securing Hardware, see the Parts Table ABOVE, under the item desired.			
12	Coil, 24-940 [NO DIODE]	1	090-5036-ND	AP-A Decals correspond to Lamp Matrix.			
COIL DOES NOT REQUIRE A DIODE. SEE ☞ COIL NOTE ABOVE FOR DETAILS.							
13	Coil Sleeve (Formost #10-7077)	1	545-5076-01				
14	Bracket, Plunger Stop	1	535-9959-00	Qty. 4			
Item 14 is secured to Item 1 by: #8-32 Nylon Stop Nut (Qty. 2) (240-5102-00)							
Ordering Note: If 500-7029-04 is unavailable, order the individual part(s) actually required for cable wiring, use Part Number 036-5523-16-93).							

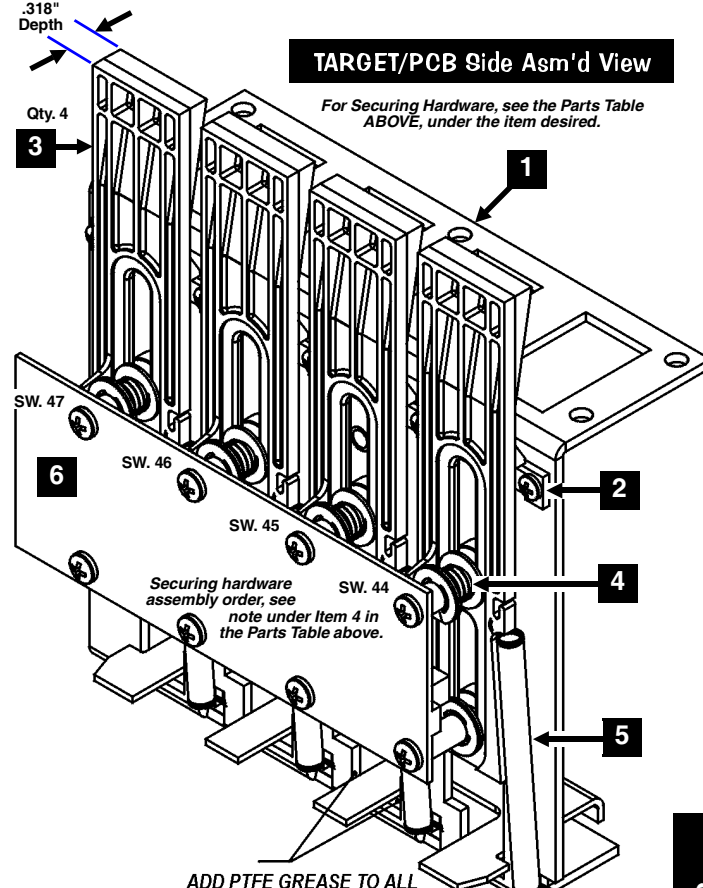
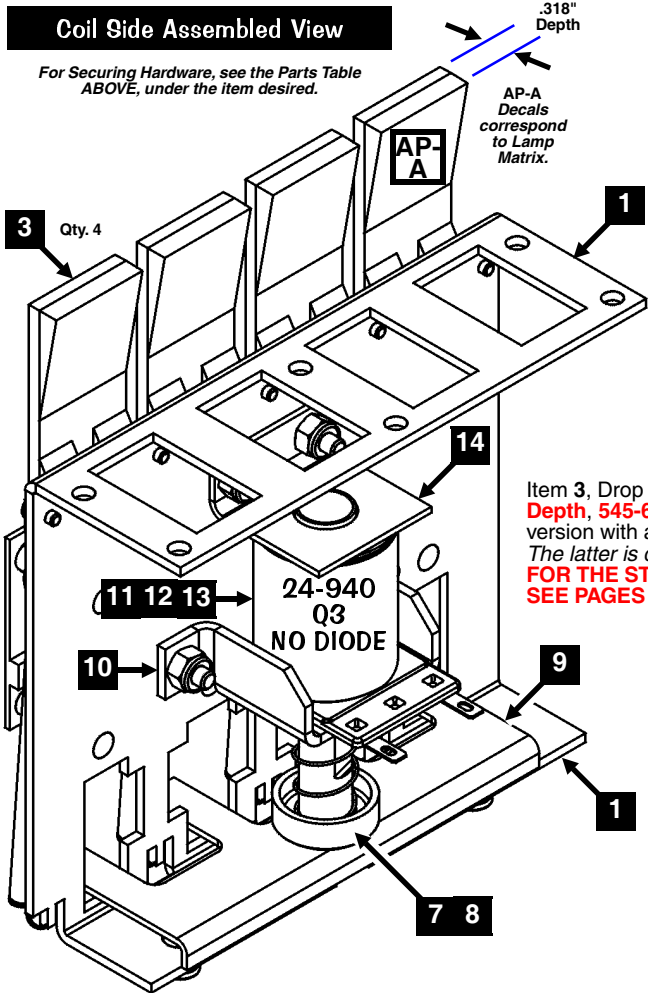

Drop Target Note:

Item 3, Drop Target (Black Plastic) Rollover with a **.468" Depth, 545-6305-00** can be substituted with the previous version with a **.318" Depth, 545-6162-00**. The latter is depicted in the assembly drawings. **FOR THE STAND-ALONE VIEW OF ITEM 3, SEE PAGES 76 & 77**

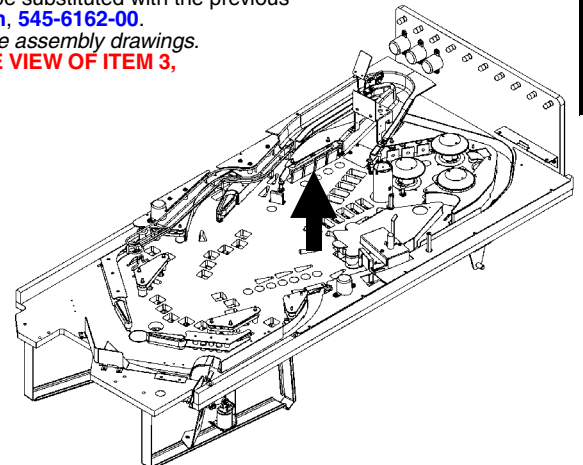

1- or 4-Bank Drop Target (500-7029-01 or 500-7029-04) Coil Side Disassembly Procedure (4-Bank Drop Target Shown)

Technicians Remember the Basics: All Service should be done by qualified personnel. **ALWAYS REMOVE POWER BEFORE SERVICING.** Service assemblies which are below the playfield, with the playfield in its' most upright position (leaning against the Backbox). Raise it carefully! Ensure the bottom edge (back) of the playfield is still resting on the Cabinet Side Support Rails and is forward enough to allow the Playfield to lean against the backbox at an angle so it does not fall forward. **When lowering, rest on the support brackets first, then continue to place in cabinet.** Re-assembly is the reverse of disassembly (removal). Keep track of securing hardware (which are referenced under the items in the Parts Table) Use **Loctite Blue 243** on the threads of all screws to ensure the screws will not loosen in play. When in doubt, give us a call!

COIL AND/OR PLUNGER-LIFT BRACKET REMOVAL:

Note: Assembly need not be removed from the playfield to perform this procedure.

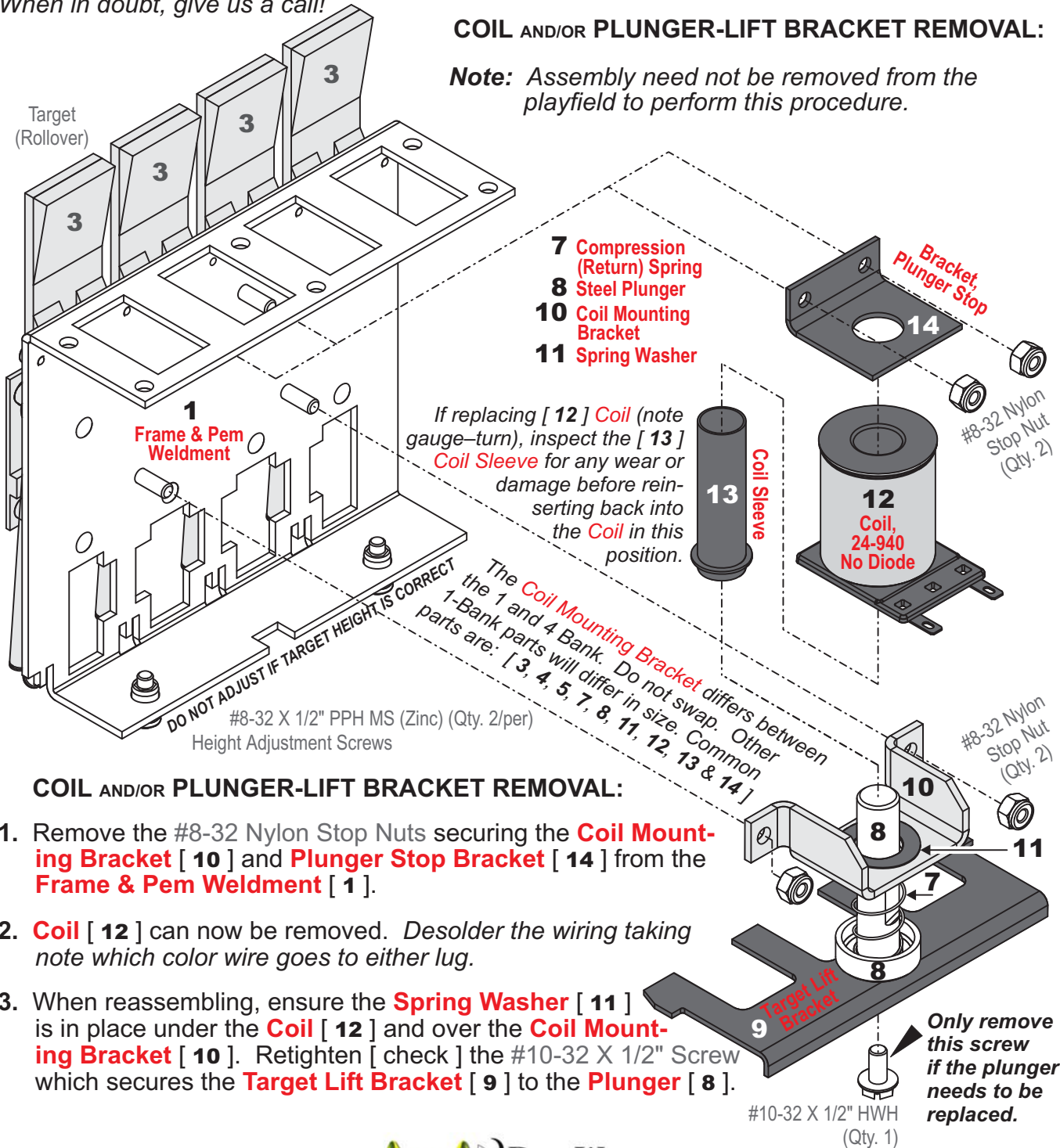

COIL AND/OR PLUNGER-LIFT BRACKET REMOVAL:

1. Remove the #8-32 Nylon Stop Nuts securing the **Coil Mounting Bracket [10]** and **Plunger Stop Bracket [14]** from the **Frame & Pem Weldment [1]**.
2. **Coil [12]** can now be removed. *Desolder the wiring taking note which color wire goes to either lug.*
3. When reassembling, ensure the **Spring Washer [11]** is in place under the **Coil [12]** and over the **Coil Mounting Bracket [10]**. Retighten [check] the #10-32 X 1/2\" Screw which secures the **Target Lift Bracket [9]** to the **Plunger [8]**.

1- or 4-Bank Drop Target (500-6946-01 or 500-7029-04)
 Target & PCB Side Disassembly Procedure (4-Bank Drop Target Shown)

Technicians Remember the Basics: All Service should be done by qualified personnel. **ALWAYS REMOVE POWER BEFORE SERVICING.** Service assemblies which are below the playfield, with the playfield in its' most upright position (leaning against the Backbox). Raise it carefully! Ensure the bottom edge (back) of the playfield is still resting on the Cabinet Side Support Rails and is forward enough to allow the Playfield to lean against the backbox at an angle so it does not fall forward. **When lowering, rest on the support brackets first, then continue to place in cabinet.** Re-assembly is the reverse of disassembly (removal). Keep track of securing hardware (which are referenced under the items in the Parts Table) Use **Loctite Blue 243** on the threads of all screws to ensure the screws will not loosen in play.

When in doubt, give us a call!

TARGET AND SPRING REMOVAL:

Note: Assembly need not be removed from the playfield to perform this procedure.

1. Remove the #6-32 x 3/8" PPH MS Screws securing the **PCB, Slotted OPTO** [6] from the **Frame & Pem Weldment** [1].
2. Remove the top [T] Retaining Ring, 1/4" ø and Washer and set aside the **Compression (Short) Spring** [4] and second Washer. Remove the bottom [B] Retaining Ring & Washer. Unhook the **Reset Spring** [5].

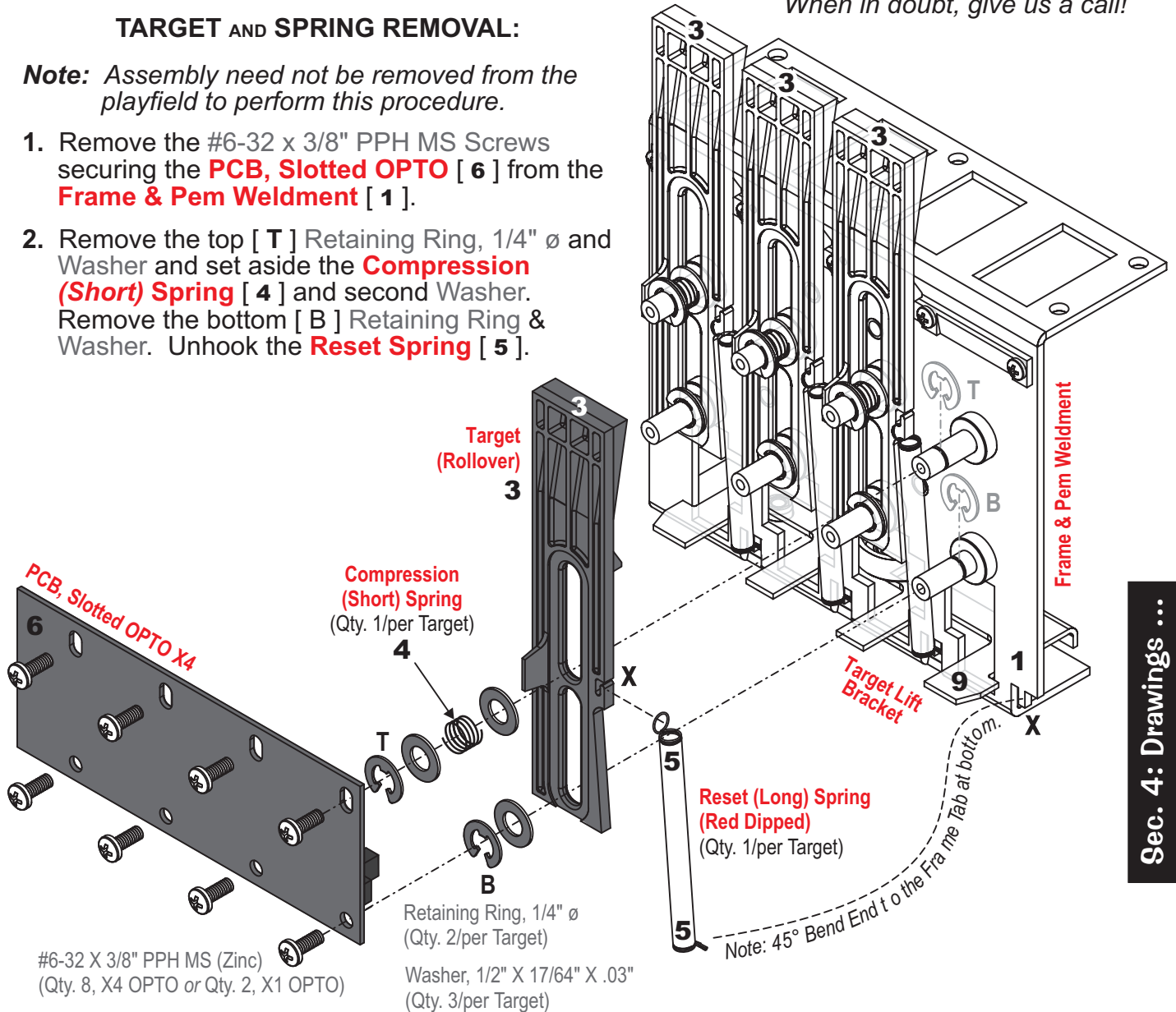

3. The **Target** [3] can now be removed. When reassembling, note the other targets. The **Compression Spring** [4] is at the top between the two Washers, secure with the top [T] Retaining Ring. When replacing the **Reset (Long) Spring** [5], hook one end to the **Target** tab [X] and the other 45° end to the tab [X] on the **Frame & Pem Weldment** [1].

Plastic Left Ramp Assembly, Individual Parts Only (Items 1-14)

[Different Views on the next page.]

Take Note:

® "R" indicates Item noted is secured with rivet(s) as listed.

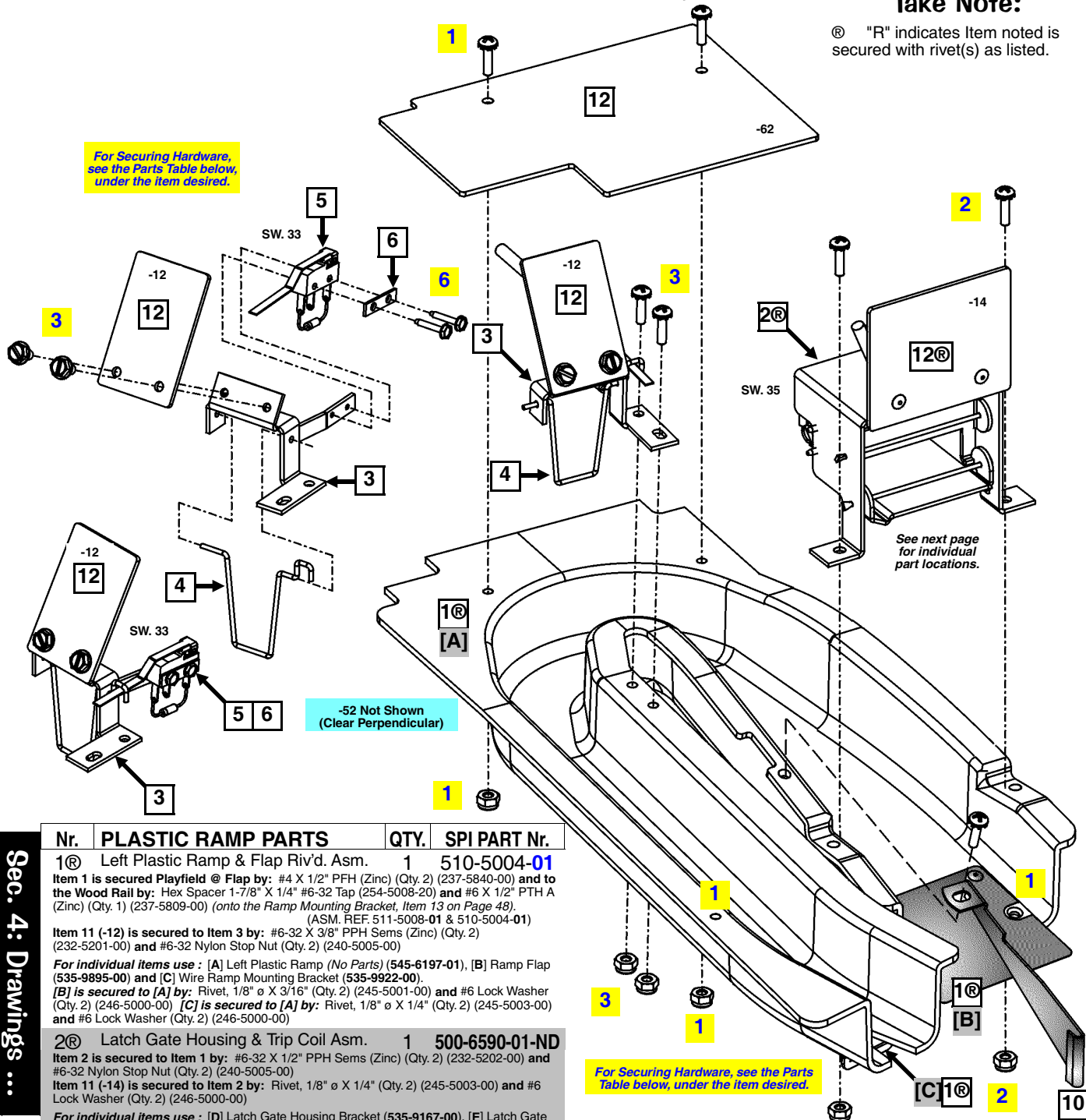

For Securing Hardware, see the Parts Table below, under the item desired.

-52 Not Shown (Clear Perpendicular)

For Securing Hardware, see the Parts Table below, under the item desired.

Sec. 4: Drawings ...

Nr.	PLASTIC RAMP PARTS	QTY.	SPI PART Nr.
1®	Left Plastic Ramp & Flap Riv'd. Asm.	1	510-5004-01
Item 1 is secured Playfield @ Flap by: #4 X 1/2" PFH (Zinc) (Qty. 2) (237-5840-00) and to the Wood Rail by: Hex Spacer 1-7/8" X 1/4" #6-32 Tap (254-5008-20) and #6 X 1/2" PTH A (Zinc) (Qty. 1) (237-5809-00) (onto the Ramp Mounting Bracket, Item 13 on Page 48). (ASM. REF. 511-5008-01 & 510-5004-01)			
Item 11 (-12) is secured to Item 3 by: #6-32 X 3/8" PPH Sems (Zinc) (Qty. 2) (232-5201-00) and #6-32 Nylon Stop Nut (Qty. 2) (240-5005-00)			
For individual items use : [A] Left Plastic Ramp (No Parts) (545-6197-01), [B] Ramp Flap (535-9895-00) and [C] Wire Ramp Mounting Bracket (535-9922-00).			
[B] is secured to [A] by: Rivet, 1/8" ø X 3/16" (Qty. 2) (245-5001-00) and #6 Lock Washer (Qty. 2) (246-5000-00) [C] is secured to [A] by: Rivet, 1/8" ø X 1/4" (Qty. 2) (245-5003-00) and #6 Lock Washer (Qty. 2) (246-5000-00)			
2®	Latch Gate Housing & Trip Coil Asm.	1	500-6590-01-ND
Item 2 is secured to Item 1 by: #6-32 X 1/2" PPH Sems (Zinc) (Qty. 2) (232-5202-00) and #6-32 Nylon Stop Nut (Qty. 2) (240-5005-00)			
Item 11 (-14) is secured to Item 2 by: Rivet, 1/8" ø X 1/4" (Qty. 2) (245-5003-00) and #6 Lock Washer (Qty. 2) (246-5000-00)			
For individual items use : [D] Latch Gate Housing Bracket (535-9167-00), [E] Latch Gate Mounting Bracket (535-9168-00), [F] Latch Gate (Flap) (535-9169-00), [G] Wire Form (Hinge) (Qty. 2) (535-9170-00), [H] Trip Coil (32-1250) Assembly (515-6916-01-ND), [I] Switch (Roller Actuator) (180-5119-02), [J] Switch Body Protect Plate (535-6539-00), [K] Diode (1N4004) (112-5003-00) and [L] Mylar Insulator (820-6315-21).			
[H] is secured to [D] by: #8-32 Nylon Stop Nut (240-5102-00) and #8 Washer (242-5005-00). [J] is secured to [I] by: #2-56 X 1/2" Uns. Ser. HWH #4HD TR3 Black Oxide (Qty. 2) (237-5937-02) (ASM. REF. 500-6590-01-A5)			
3	Exit Gate Mounting Bracket	1	535-6303-03
Item 3 is secured to Item 1 by: #6-32 X 1/2" PPH Sems (Zinc) (Qty. 2) (232-5202-00) and #6-32 Nylon Stop Nut (Qty. 2) (240-5005-00) (ASM. REF. 515-6490-09)			
Item 11 (-15) is secured to Item 3 by: #6-32 X 1/4" SHWH Sw. (Zc.) (Qty. 2) (237-5976-01)			
4	Exit Gate Wire Form	1	535-6304-03
5	Switch, Exit Gate	1	180-5087-00
Switch has a Diode (1N4004) (112-5003-00). Can be replaced with (1N4001) (112-5001-00).			
6	Switch Body Protect Plate	1	535-6539-00
Items 5 & 6 are secured to Item 3 by: #2-56 X 1/2" Uns. Ser. HWH #4HD TR3 Black Oxide (Qty. 2) (237-5937-02)			

Nr.	PLASTIC RAMP PARTS	QTY.	SPI PART Nr.
7	Wedge Base Socket (Laydown)	1	077-5026-01
Item 7 is secured to Items 1 & 11 (left hole) by: Rivet, 1/8" ø X 1/4" (Qty. 1) (245-5003-00) and #6 Lock Washer (Qty. 1) (246-5000-00) (ASM. REF. 511-5053-03)			
8	#555 Wedge Base Bulb (Clear)	1	165-5002-00
9	Light Reflector (Silver Plastic)	1	545-5409-01
10	Ramp Guard, Left Side	1	535-9981-00
Item 10 is secured to Item 1 by: #6-32 X 3/8" PPH Sems (Zinc) (Qty. 1) (232-5201-00)			
11	Kit: Decal (incl. -27 Castle Guard)	1	802-5000-A5
Note: Individual Decals (820-6412-XX) are not available individually, ordering of kit is required.			
12®	Kit: Plastics (incl. -14, -15 & -52, -62)	1	803-5000-A5
Note: Individual Plastics (830-6074-XX & 830-6075-XX) are not available individually, ordering of kit is required.			



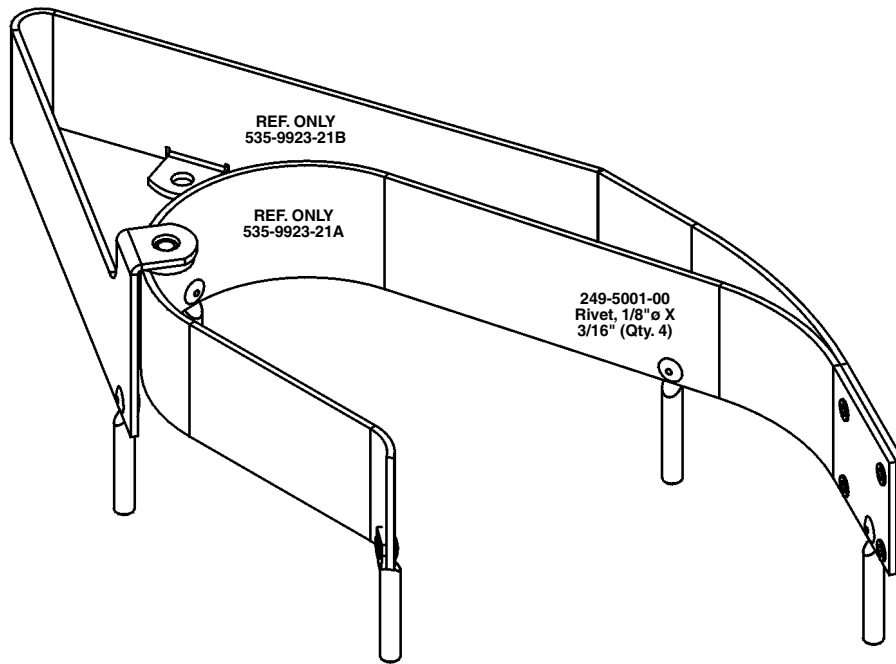

Flat Ramp & Flap (Riveted) Asm., Individual Parts Only (Item FR23, Page 52) ▼

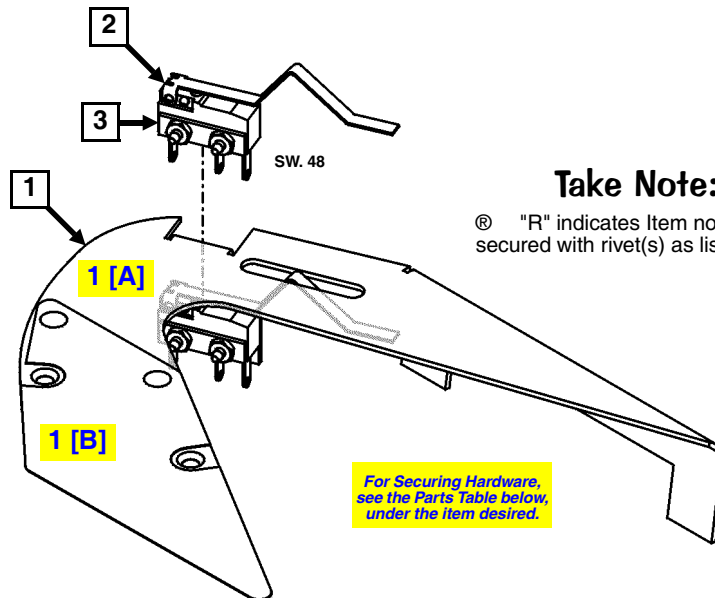

Take Note:

® "R" indicates Item noted is secured with rivet(s) as listed.

Nr.	METAL RAMP PARTS	QTY.	SPI PART Nr.
1®	Metal Ramp & Flap Riveted Assembly	1	510-5006-00
Item 1 is secured Playfield @ Flap by: #4 X 5/8" PFH (Black) (Qty. 2) (237-5833-00) (ASM. REF. 511-5002-00)			
<i>For individual items use :</i> [A] Metal Ramp (No Parts) (535-9900-00) and [B] Ramp Flap (535-9901-00).			
<i>[B] is secured to [A] by:</i> Rivet, 1/8" ø X 3/16" (Qty. 2) (245-5001-00) and #6 Lock Washer (Qty. 2) (246-5000-00)			
2	Switch (Happ #95-1128-00)	1	180-5183-00
Switch has a Diode (1N4004) (112-5003-00). Can be replaced with (1N4001) (112-5001-00).			
3	Switch Body Protect Plate	1	535-6539-00
Items 2 & 3 are secured to Item 1 by: #2-56 X 1/2" Uns. Ser. HWH #4HD TR3 Black Oxide (Qty. 2) (237-5937-02) and #2-56 Hex Nut (Qty. 2) (240-5301-00).			

Sec. 4: Drawings ...

Yellow Wire Ramp, 535-9920-01
(Item WRI, Page 52)

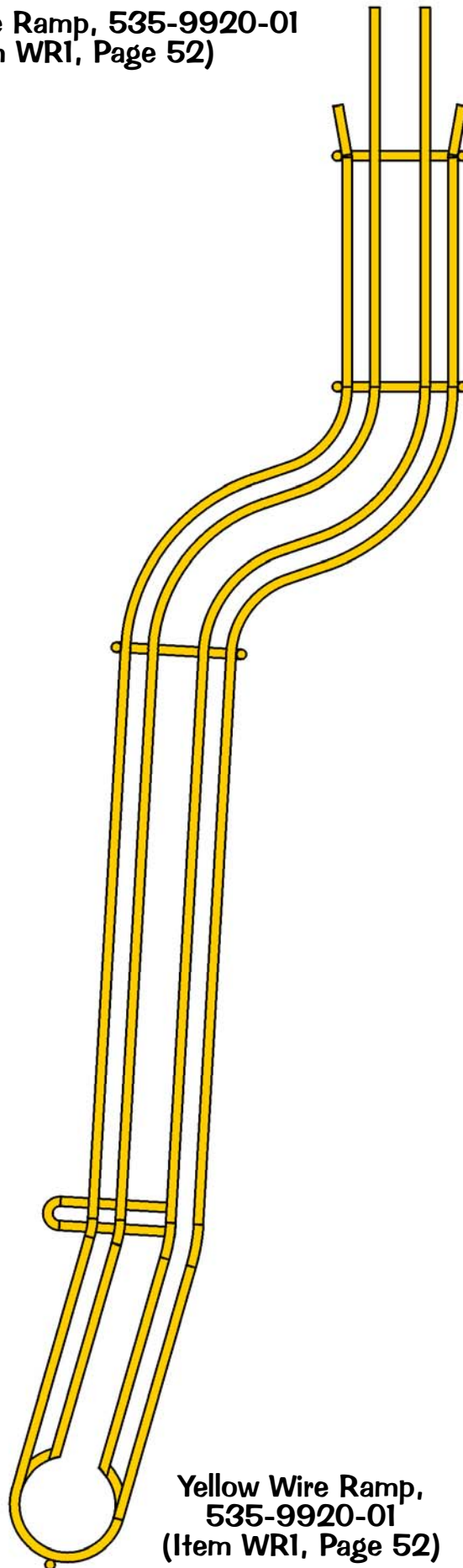

Yellow Wire Ramp,
535-9920-01
(Item WRI, Page 52)

Sec. 4: Drawings ...

Magic Mirror [Prince Charming] Assembly, Individual Parts Only (Items 1-13)

For Securing Hardware,
see the Parts Table below,
under the item desired.

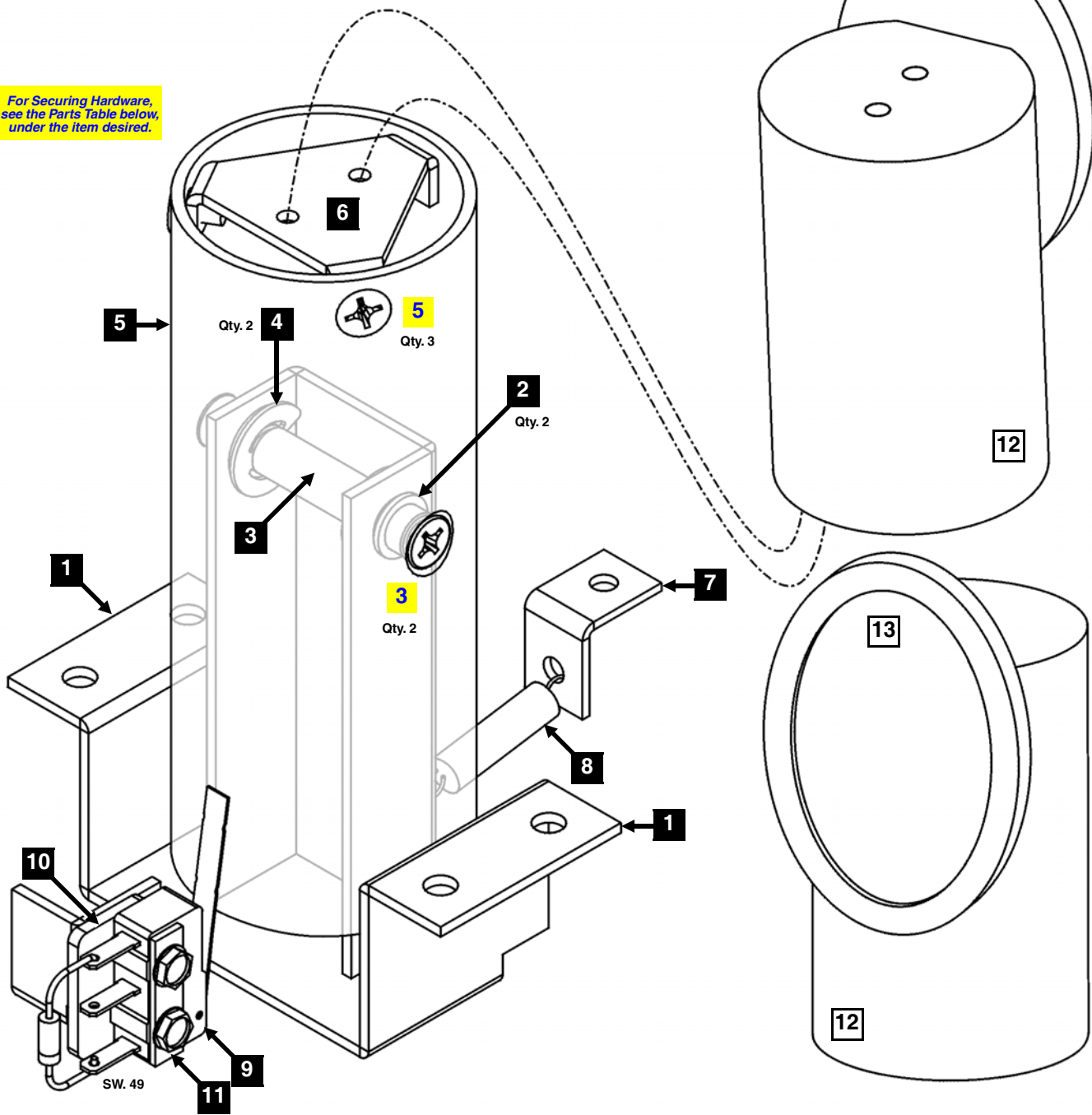

Sec. 4: Drawings ...

Nr.	MAGIC MIRROR PARTS	QTY.	SPI PART Nr.	Nr.	MAGIC MIRROR PARTS	QTY.	SPI PART Nr.
1	Bracket Weldment, Can Mount. Item 1 is secured under the playfield by: #8 X 1/2" SHWH AB (Zc.) (Qty. 4) (234-5101-00) (ASM. REF. 500-7025-01, Items 1-11 ONLY)	1	535-9896-00	8	Compression (Return) Spring	1	265-5035-00
2	Nyliner 1/4" ø (4L1-FF Thomson)	1	545-5423-00	9	Switch (Omron SS-01-FT) Switch has a Diode (1N4004) (112-5003-00). Can be replaced with (1N4001) (112-5001-00).	1	180-5190-28
3	Shaft (Can Pivot) Item 3 is secured to Item 5 by: #8-32 X 5/16" PFH 82° U/C MS Undercut (Zinc) (Qty. 2) (237-6030-01)	1	530-5745-00	10	Kit: Plastic (incl. -SP) Note: See "Kit Note Required" under Item 13.	1	803-5000-A5
4	Retaining Ring, 1/4" ø	2	270-5002-00	11	Switch Body Protect Plate Items 9-11 are secured to Item 1 by: #2-56 X 1/2" Uns. Ser. HWH #4HD TR3 Black Oxide (Qty. 2) (237-5937-02)	1	535-6539-00
5	Can	1	535-9899-00	12	Magic Mirror (Rotomold) Item 12 is secured to Item 6 by: #6-32 X 3/8" PPH Sems (Zinc) (Qty. 2) (232-5201-00) and #6 Washer (Qty. 2) (242-5000-00) (ASM. REF. 511-5121-00, Items 12-13, see Note).	1	880-5099-05
6	Figurine Mounting (Spider) Bracket Item 6 is secured to Item 5 by: #6-32 X 1/4" PFD MS 82 Undercut (Zinc) (Qty. 3) (237-5871-01)	1	535-9898-01	13	Kit: Decal (includes 820-6426-00) Note: Individual Plastics (830-6074-XX & 830-6075-XX) and Decals (820-6412-XX & 820-6426-00) are not available individually, ordering of kit is required.	1	802-5000-A5
7	Bracket, Spring & Can Mounting Item 7 is secured under the P/F by: #6 X 1/2" HWH AB (Zinc) Red (Qty. 1) (234-5001-02)	1	535-8941-04				

Donkey & Motor Assembly, Individual Parts Only (Items 1-7)

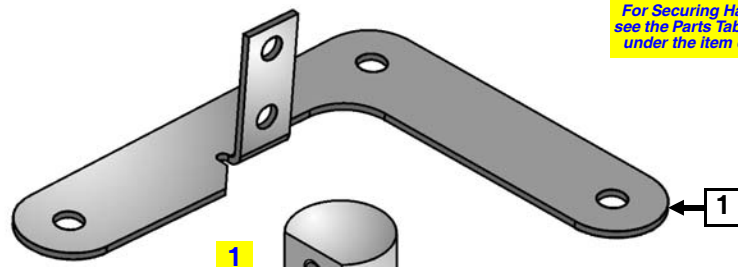

For Securing Hardware, see the Parts Table below, under the item desired.

After securing Item 4, Donkey Platform, to Item 5, Adaptor, correctly (set screw onto the "flat" of the Adaptor) **YOU MUST PERFORM** the Donkey Motor Test in **DIAGNOSTICS**. See Section 3, Chapter 2, Page 17, Donkey Motor Test, for details.

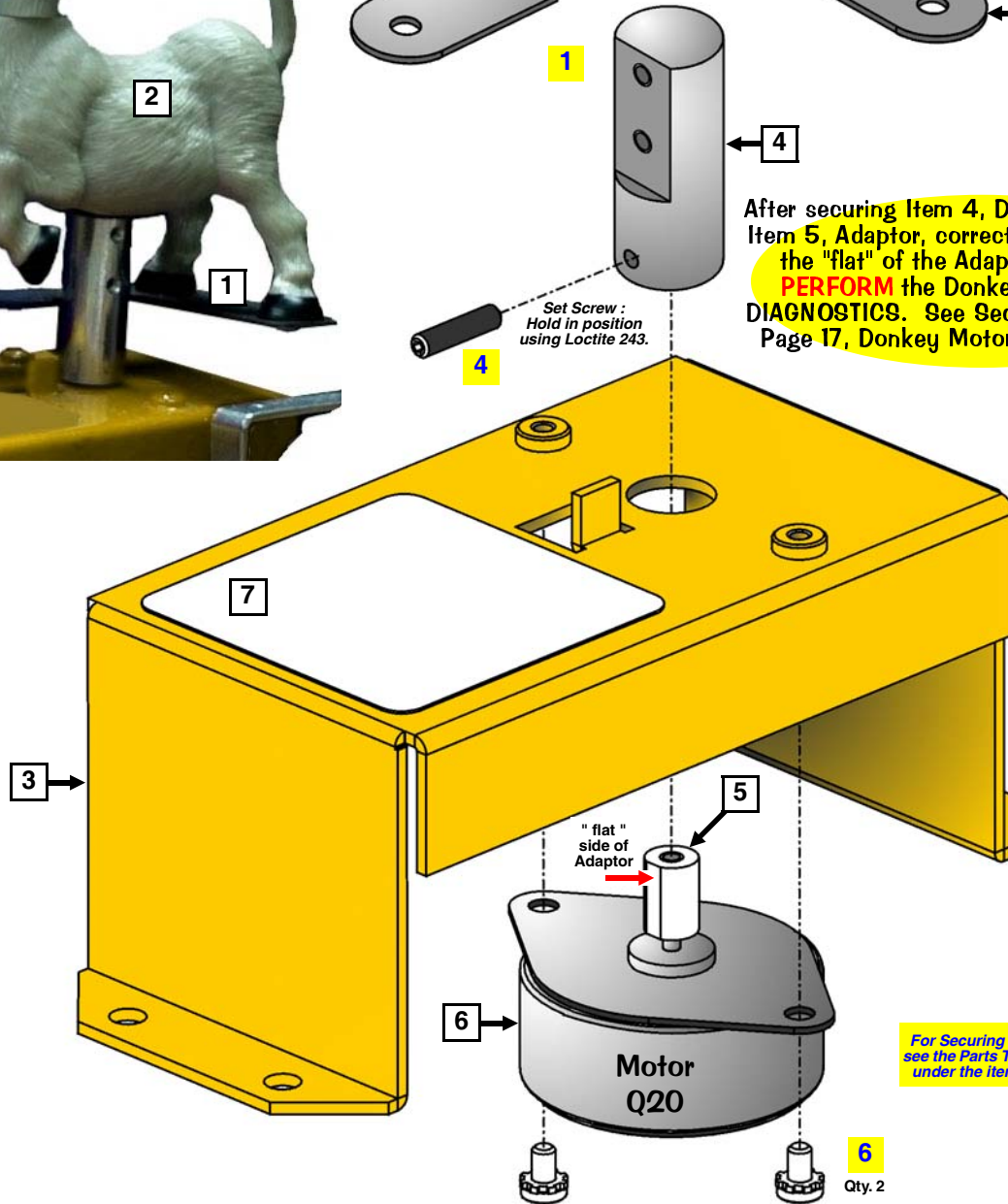

For Securing Hardware, see the Parts Table below, under the item desired.

Sec. 4: Drawings ...

Nr.	DONKEY & MOTOR PARTS	QTY.	SPI PART Nr.	Nr.	DONKEY & MOTOR PARTS	QTY.	SPI PART Nr.
1	Bracket, Support (for Donkey)	1	535-0126-00	5	Adaptor (for Motor Shaft)	1	530-5748-00
2	Donkey Figurine (Modified)	1	880-5099-01-01	<i>Note : Press Item 5 Adaptor onto the Motor Shaft. Ensure that it's flush with top.</i>			
	Donkey Figurine (RoHS/Modified)	1	880-5099-01-03	6	Stepper Motor & Connector	1	511-5043-00
	Item 2 is secured to Item 1 by: #4 X 3/8" PPH AB (Zinc) (Qty. 3) (237-5815-00) and secured to Item 4 by: #4-40 X 3/8" PPH Mx. Black Zinc Oxide (Qty. 2) (237-5997-00) (ASM. REF. 511-5093-01, Items 1-2 ONLY)			<i>For Individual Items use : Stepper Motor NPM PF35T-48D4STD 5V RVB (041-5102-00), 6-Pin Connector (045-5157-06) and 4" Cable Tie (040-5001-01). (ASM. REF. 511-5007-00, Items 5-6 ONLY)</i>			
3	Donkey Platform & Motor Mount	1	515-7605-00	<i>Item 6 works with the Stepper Motor Controller PCB Asm. (511-5045-00). For more information and wiring colors, schematics and parts of this PCB, see Section 5, Chapter 4, Printed Circuit Boards (PCBs), Page 142.</i>			
	Item 3 is secured above the playfield by: #8 X 1/2" SHWH AB (Zc.) (Qty. 4) (234-5101-00) (ASM. REF. 500-7030-01, Items 3-6 ONLY)			7	Kit: Decal (incl. -28 Donkey)	1	802-5000-A5
4	Yellow (Donkey) Platform & Mtr. Mount	1	530-5747-01	<i>Note: Individual Decals (820-6394-XX) are not available individually, ordering of kit is required.</i>			
	Item 4 is secured over Item 5 by: #4-40 X 1/2" Long Cup-Point Set Screw (237-6183-00) <i>Note : Use Loctie 243 (000-0632-00) before reinserting.</i>						

Shrek, Fiona & Gingy Figurines and Mounting Brackets, Indi. Parts Only (Items 1-5)
 (For Puss In Boots, see Plastic Left Ramp Assembly, Pages 82-83;
 for Donkey, see Donkey & Motory Assembly, Page 87)

Nr.	S., F. & G. FIGURINE PARTS	QTY.	SPI PART Nr.	Nr.	S., F. & G. FIGURINE PARTS	QTY.	SPI PART Nr.	
1	Shrek Figurine (Modified)	1	880-5099-00-01	4	Gingy Figurine (Modified)	1	880-5099-03-01	
	Shrek Figurine (RoHS/Modified)	1	880-5099-00-03		Gingy Figurine (RoHS/Modified)	1	880-5099-03-03	
Item 1 is secured to Plastic -06 by: #6 X 1/2" PTH A (Zinc) (Qty. 1) (237-5809-00)				5* Bracket, Support (for Gingy)				1 535-0124-00
2	Fiona Figurine (Modified)	1	880-5099-02-01	Item 15 is secured by: #6 X 1/2" HWH AB Zinc Red (Qty. 2) (234-5001-02) and @ figurine by: #6-32 X 3/8" PPH Sems (Zinc) (Qty. 1) (232-5201-00) and #6-32 X 7/8" PPH MS Ext. Sems (Zinc) (Qty. 1) (232-5205-00)				
	Fiona Figurine (RoHS/Modified)	1	880-5099-02-03					
3*	Bracket, Support (for Fiona)	1	535-0132-00					
Item 14 is secured by: #6-32 X 1-1/4" PPH MS (Zinc) (Qty. 1) (237-5508-00), #6-32 X 1-1/2" PPH MS (Zinc) (Qty. 1) (237-5510-00) and @ figurine by: #6-32 X 7/8" PPH MS Ext. Sems (Zinc) (Qty. 2) (232-5205-00) and Spacer 5/8" X 3/8" (Qty. 2) (254-5000-14)								



1

1



2

For Securing Hardware, see the Parts Table above, under the item desired.

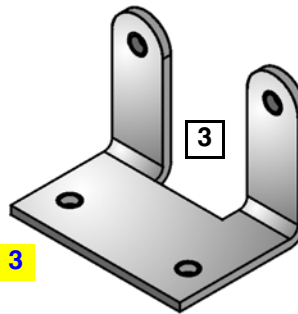

3



4

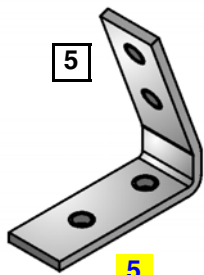

5

5

Sec. 4: Drawings ...

Back Panel Assembly, Individual Parts Only (Items 1-10)

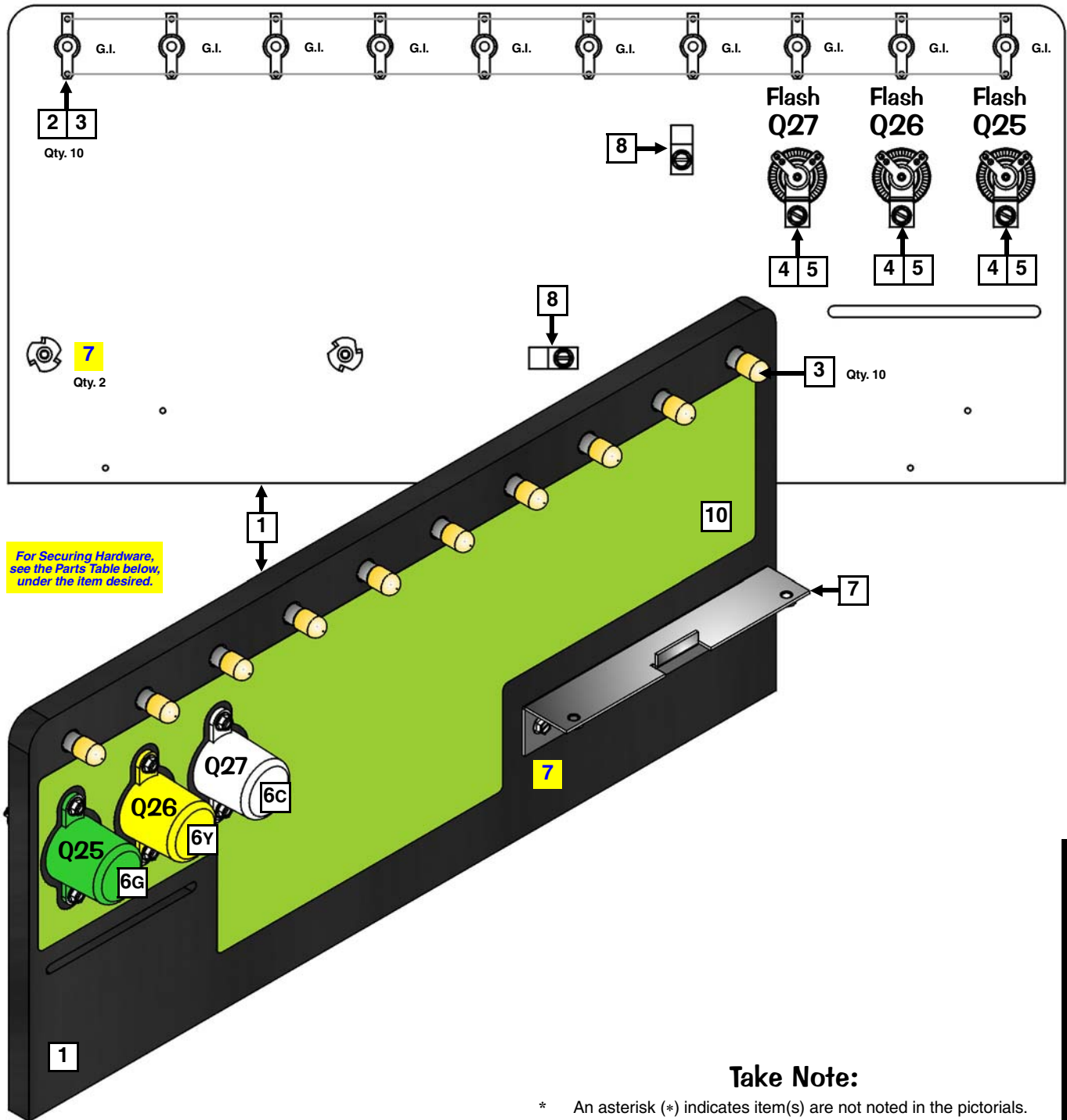

Take Note:

* An asterisk (*) indicates item(s) are not noted in the pictorials.

Nr.	BACK PANEL PARTS	QTY.	SPI PART Nr.	Nr.	BACK PANEL PARTS	QTY.	SPI PART Nr.
1	Back Panel (No Parts) Black Wood	1	525-5683-00	7	Donkey Mini-Pin. Rear Mnt. Bracket	1	535-9975-00
Item 1 is secured below the playfield with by Item 9: #8 X 1/2" SHWH AB (Zinc) (Qty. 2/per) (234-5101-00) (ASM. REF. 500-7032-00-A5, Items 1-8 ONLY)				Item 7 is secured to Item 1 by: #8-32 X 5/8" SHWH Ser. Swage (Zinc) (Qty. 2) (237-5975-03) and #8-32 T-Nut (Qty. 2) (240-5101-00)			
2	Socket, 2-Lug Staple Down	10	077-5000-00	8	Clamp, 1/4" (Single)	2	040-5000-03
3	#44 Bulb (Yellow) <i>Heavy Filament</i>	10	165-5053-06-HF	Item 8 is secured to Item 1 by: #6 X 3/8" HWH (Qty. 1/per) (234-5000-00)			
4	Socket, 2-Lug Stand-Up Short	3	077-5101-00	9*	Bracket, Back Panel Mounting	2	535-8964-00
Item 4 is secured to Item 1 by: #6 X 3/8" HWH Screw (Qty. 1/per) (234-5000-00)				Item 9 is secured to 1 by: #8 X 1/2" SHWH AB (Zinc) (Qty. 2/per) (234-5101-00) Note: For playfield location, see Page 49, Item 11.			
5	#89 Bulb (Clear) <i>Heavy Filament</i>	10	165-5000-89-HF	10	Kit: Decal (incl. -10 Back Panel)	1	802-5000-A5
6G	Light Cover with tabs (Fluor. Green)	1	550-5031-11	Note: Individual Decals (820-6412-XX) are not available individually, ordering of kit is required.			
6Y	Light Cover with tabs (Yellow)	1	550-5031-06				
6C	Light Cover with tabs (Clear)	1	550-5031-01				
Items 6B, 6R & 6C are secured by: #8 X 1/2" SHWH AB (Zinc) (Qty. 2/per) (234-5101-00)							

Donkey Mini-Pinball Assembly Overview

Reference 500-7018-00-A5

Mini-Playfield Screened with Inserts (No Parts) 830-51A5-01

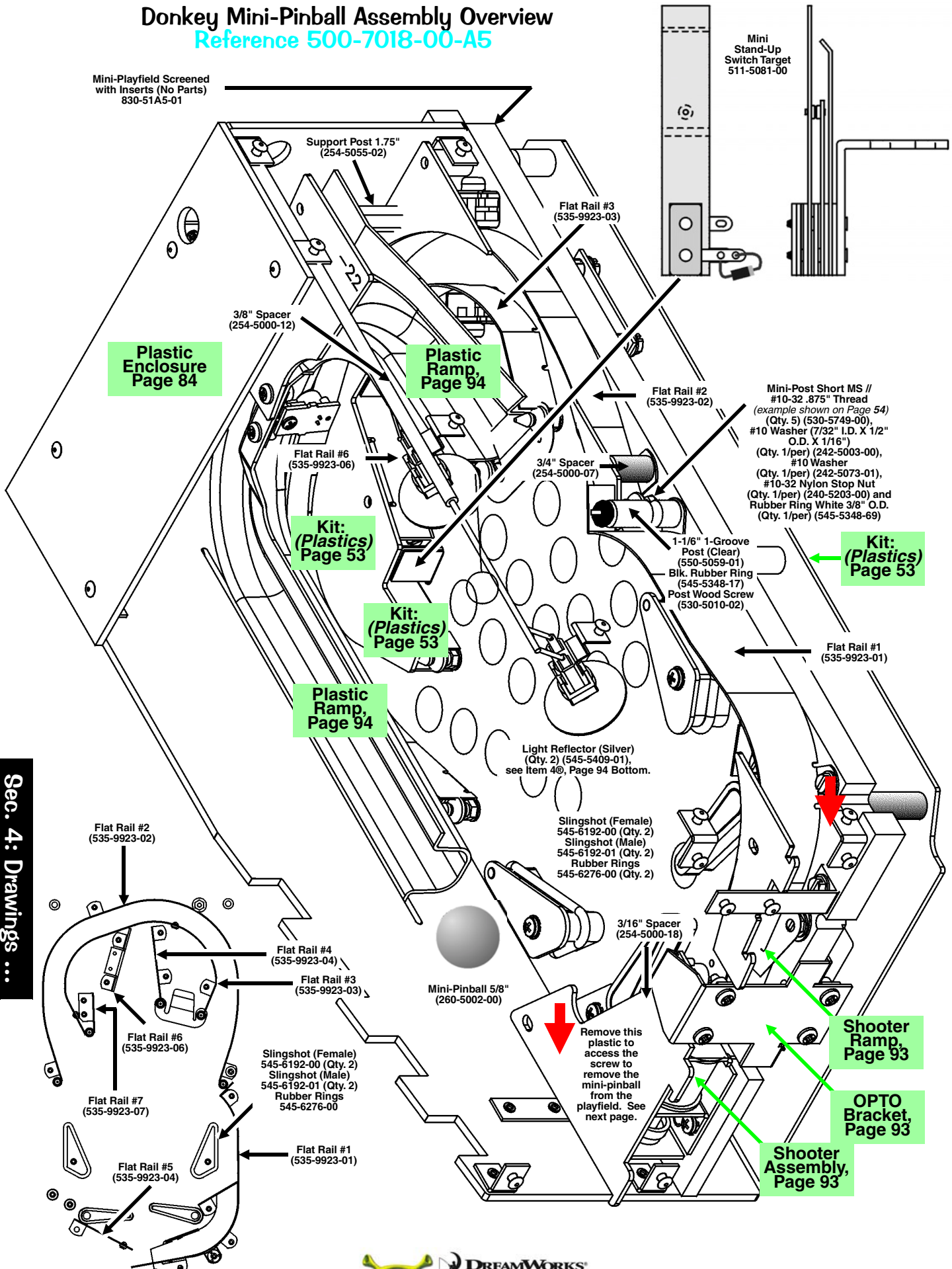

Plastic Enclosure Page 84

Plastic Ramp, Page 94

Kit: (Plastics) Page 53

Kit: (Plastics) Page 53

Plastic Ramp, Page 94

Kit: (Plastics) Page 53

Shooter Ramp, Page 93

OPTO Bracket, Page 93

Shooter Assembly, Page 93

Remove this plastic to access the screw to remove the mini-pinball from the playfield. See next page.

Mini Stand-Up Switch Target 511-5081-00

Mini-Post Short MS // #10-32 .875" Thread (example shown on Page 54) (Qty. 5) (530-5749-00), #10 Washer (7/32" I.D. X 1/2" O.D. X 1/16") (Qty. 1/per) (242-5003-00), #10 Washer (Qty. 1/per) (242-5073-01), #10-32 Nylon Stop Nut (Qty. 1/per) (240-5203-00) and Rubber Ring White 3/8" O.D. (Qty. 1/per) (545-5348-69)

Light Reflector (Silver) (Qty. 2) (545-5409-01), see item 4@, Page 94 Bottom.

Slingshot (Female) 545-6192-00 (Qty. 2) Slingshot (Male) 545-6192-01 (Qty. 2) Rubber Rings 545-6276-00 (Qty. 2)

Mini-Pinball 5/8" (260-5002-00)

Sec. 4: Drawings ...



Donkey Mini-Pinball Assembly, Overview Continued

Reference 500-7018-00-A5

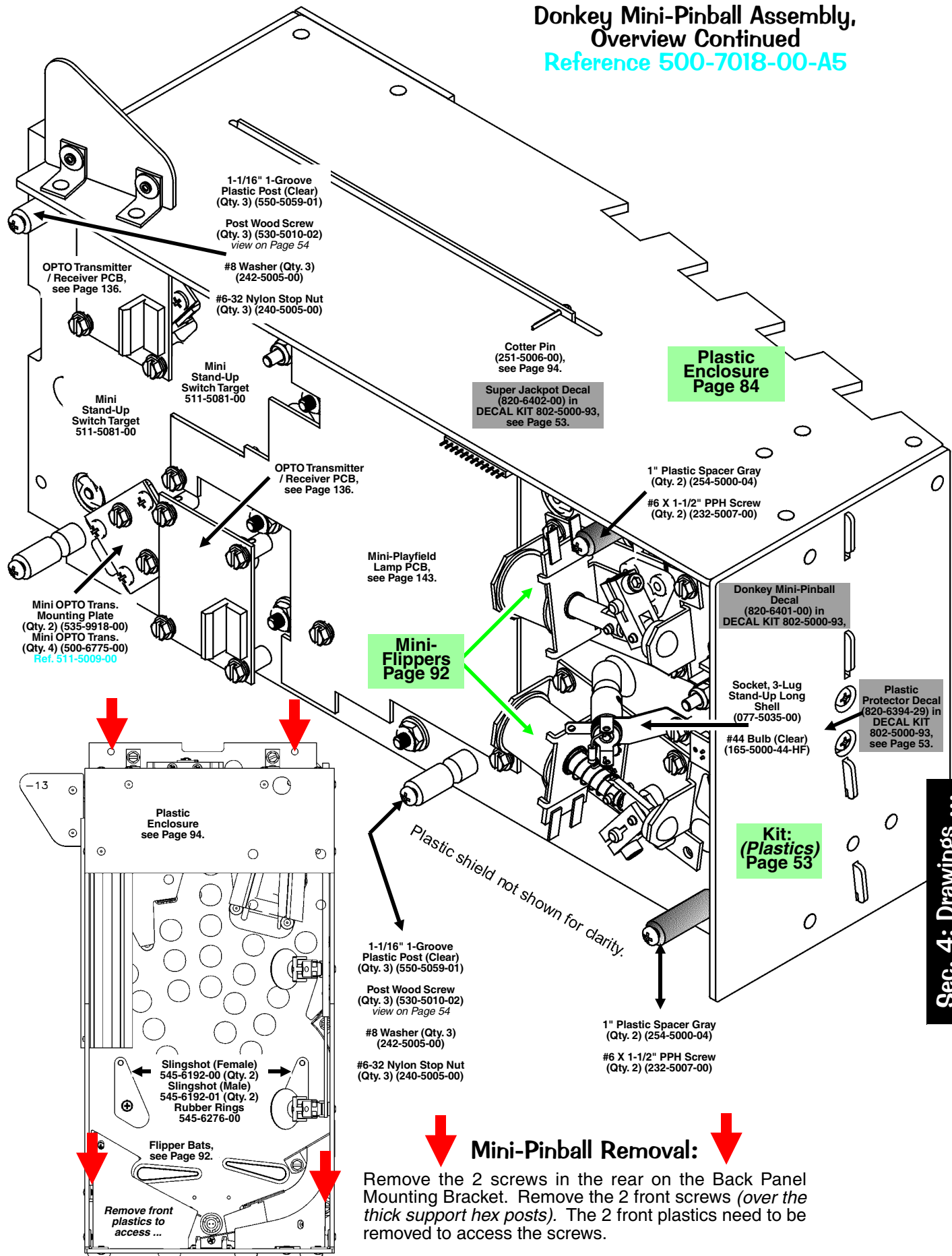

Sec. 4: Drawings ...

Mini-Pinball Removal:

Remove the 2 screws in the rear on the Back Panel Mounting Bracket. Remove the 2 front screws (over the thick support hex posts). The 2 front plastics need to be removed to access the screws.



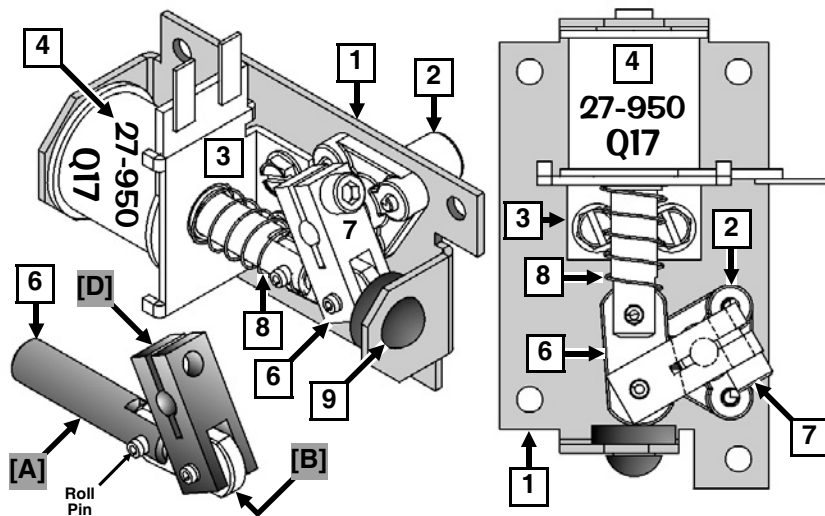

**Mini-Playfield Flipper (Left)
Assembly, 500-7019-00
(Items 1-9)**
and Associated Parts: Yellow
Mini-Flipper Bat & Shaft Assembly,
515-7591-06 (Items AP-A/-B)

Take Note:

☹ **Coil Note:** ☹ **NO DIODE ON LUGS.** If replacing with a coil of the same gauge and turn and it has a diode on it, remove it before using.

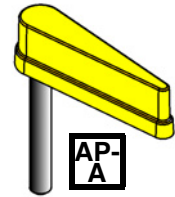

For Securing Hardware, see the Parts Table below, under the item desired.

Nr.	MINI-FLIPPER PARTS	QTY.	SPI PART Nr.
1	Bracket, Flipper Base Plate (LEFT) Item 1 is secured below the playfield by: #8 X 1/2" SHWH AB (Zc.) (Qty. 4) (234-5101-00)	1	515-7590-00
2	Mini-Flipper Bat Bushing (Plastic) Item 2 is secured to Item 1 by: #6 X 5/16" PPH (Zinc) Type-25 (Qty. 3) (237-5880-01)	1	545-6186-00
3	Bracket, Mini-Coil Retainer Item 3 is secured to Item 1 by: #6-32 X 1/4" SHWH Ser. Swage (Zinc) Wax (Qty. 2) (237-5976-01)	1	535-9871-00
4	Mini-Coil, 27-950 [NO DIODE] COIL DOES NOT REQUIRE A DIODE. SEE ☹ COIL NOTE ABOVE FOR DETAILS.	1	090-5046-01-ND
5	Mini-Coil Sleeve	1	545-5442-00
6	Mini-Plunger Assembly	1	511-5000-00

For Individual Items use : [A] Mini-Plunger (530-5734-00), [B] Mini-Flipper Link (545-6185-00), [C] Crank Bushing (530-5737-00) and [D] Mini-Crank Bar (530-5738-00).
Note : 6[C] located in 6[D] on 6[B] side. ◀ 6[B] is secured to 6[A] / [D] by: Roll (Spring) Pin .125" X .5" (Qty. 2) (251-5041-00)

Nr.	MINI-FLIPPER PARTS	QTY.	SPI PART Nr.
7	Set Screw: #8-32 X 3/8" SHCS (Zinc) Assembly Note : Crank must be oriented so that the slot does not interfere with the link (screw head should be pointed away from the coil).	1	237-5897-00
8	Mini-Compression (Relay) Spring	1	266-5091-00
9	Rubber Bumper (Grommet) Ordering Note : If 500-7019-00 is unavailable, order the individual part(s) actually required. All parts are identical to 500-7019-01 except for Item 1, Bracket, Flipper Base Plate (515-7590-01).	1	545-5105-00

ASSOCIATED PARTS ARE NOT INCLUDED WITH THE ABOVE ASSEMBLY.

Nr.	ASSOCIATED PART(S)	QTY.	SPI PART Nr.
AP-A	YEL. Mini-Flipper Bat & Shaft Asm.	1	515-7591-06
AP-B	Mini-Flipper BLACK Rubber Ring	1	545-6187-00

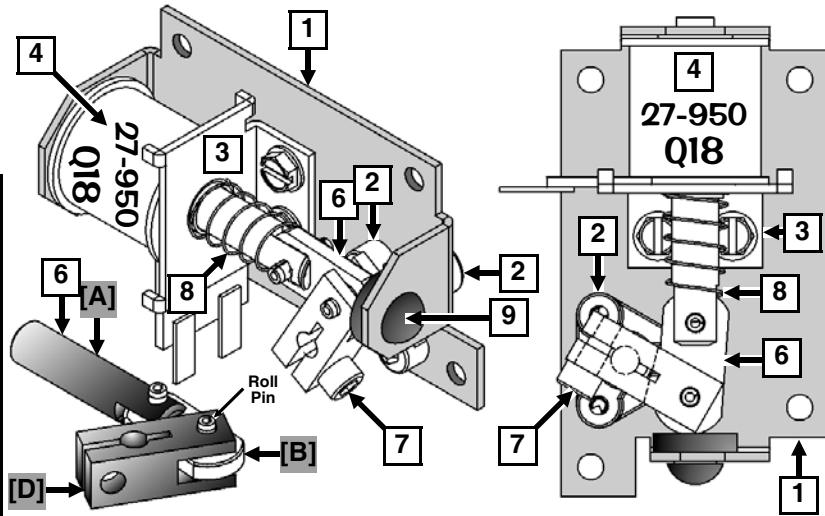

**Mini-Playfield Flipper (Right)
Assembly, 500-7019-01
(Items 1-9)**
and Associated Parts: Yellow
Mini-Flipper Bat & Shaft Assembly,
515-7591-06 (Items AP-A/-B)

Take Note:

☹ **Coil Note:** ☹ **NO DIODE ON LUGS.** If replacing with a coil of the same gauge and turn and it has a diode on it, remove it before using.

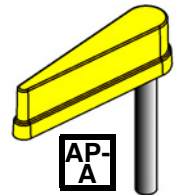

For Securing Hardware, see the Parts Table below, under the item desired.

Nr.	MINI-FLIPPER PARTS	QTY.	SPI PART Nr.
1	Bracket, Flipper Base Plate (RIGHT) Item 1 is secured below the playfield by: #8 X 1/2" SHWH AB (Zc.) (Qty. 4) (234-5101-00)	1	515-7590-01
2	Mini-Flipper Bat Bushing (Plastic) Item 2 is secured to Item 1 by: #6 X 5/16" PPH (Zinc) Type-25 (Qty. 3) (237-5880-01)	1	545-6186-00
3	Bracket, Mini-Coil Retainer Item 3 is secured to Item 1 by: #6-32 X 1/4" SHWH Ser. Swage (Zinc) Wax (Qty. 2) (237-5976-01)	1	535-9871-00
4	Mini-Coil, 27-950 [NO DIODE] COIL DOES NOT REQUIRE A DIODE. SEE ☹ COIL NOTE ABOVE FOR DETAILS.	1	090-5046-01-ND
5	Mini-Coil Sleeve	1	545-5442-00
6	Mini-Plunger Assembly	1	511-5000-00

For Individual Items use : [A] Mini-Plunger (530-5734-00), [B] Mini-Flipper Link (545-6185-00), [C] Crank Bushing (530-5737-00) and [D] Mini-Crank Bar (530-5738-00).
Note : 6[C] located in 6[D] on 6[B] side. ◀ 6[B] is secured to 6[A] / [D] by: Roll (Spring) Pin .125" X .5" (Qty. 2) (251-5041-00)

Nr.	MINI-FLIPPER PARTS	QTY.	SPI PART Nr.
7	Set Screw: #8-32 X 3/8" SHCS (Zinc) Assembly Note : Crank must be oriented so that the slot does not interfere with the link (screw head should be pointed away from the coil).	1	237-5897-00
8	Mini-Compression (Relay) Spring	1	266-5091-00
9	Rubber Bumper (Grommet) Ordering Note : If 500-7019-01 is unavailable, order the individual part(s) actually required. All parts are identical to 500-7019-00 except for Item 1, Bracket, Flipper Base Plate (515-7590-00).	1	545-5105-00

ASSOCIATED PARTS ARE NOT INCLUDED WITH THE ABOVE ASSEMBLY.

Nr.	ASSOCIATED PART(S)	QTY.	SPI PART Nr.
AP-A	YEL. Mini-Flipper Bat & Shaft Asm.	1	515-7591-06
AP-B	Mini-Flipper BLACK Rubber Ring	1	545-6187-00

Sec. 4: Drawings ...



Mini-Playfield Shooter Assembly, 500-7023-00 (Items 1-7)

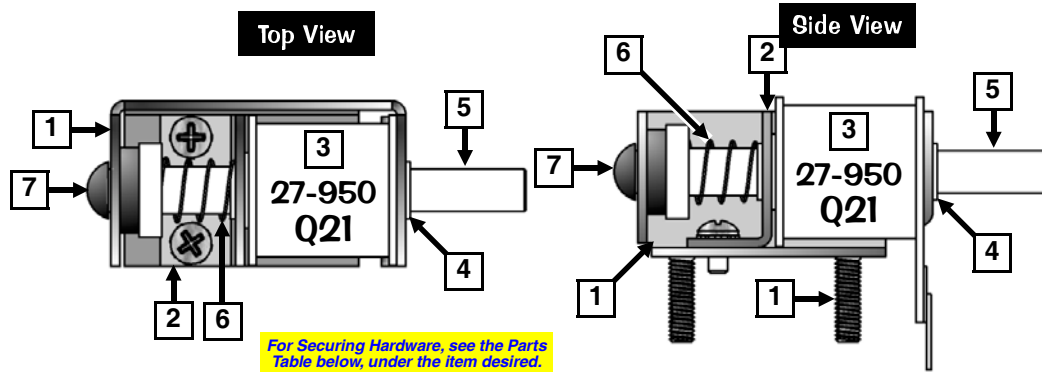

For Securing Hardware, see the Parts Table below, under the item desired.

Nr.	MINI-SHOOTER PARTS	QTY.	SPI PART Nr.	Nr.	MINI-SHOOTER PARTS	QTY.	SPI PART Nr.
1	Bracket, Shooter / Mini-Kicker Item 1 is secured below the playfield by: #8 Washer (Qty. 2) (242-5005-00) and #8-32 Nylon Stop Nut (Qty. 2) (240-5102-00)	1	515-7598-00	4	Mini-Coil Sleeve (diff. from mini-flips)	1	545-5500-00
2	Bracket, Mini-Coil Retainer Item 2 is secured to Item 1 by: #6-32 X 1/4" PPH MS Sems (Zinc) (Qty. 2) (232-5200-00)	1	535-9886-00	5	Mini-Plunger Assembly Individual Items Reference Only : [A] Mini-Plunger Tip 1.36" (530-5740-01) and [B] Mini-Plunger Bottom (530-5741-00)	1	515-7594-01
3	Mini-Coil, 27-950 [NO DIODE] COIL DOES NOT REQUIRE A DIODE. SEE COIL NOTE ABOVE FOR DETAILS.	1	090-5046-01-ND	6	Mini-Compression (Relay) Spring	1	266-5091-00
				7	Rubber Bumper (Grommet)	1	545-5105-00

Ordering Note: If 500-7023-00 is unavailable, order the individual part(s) actually required.

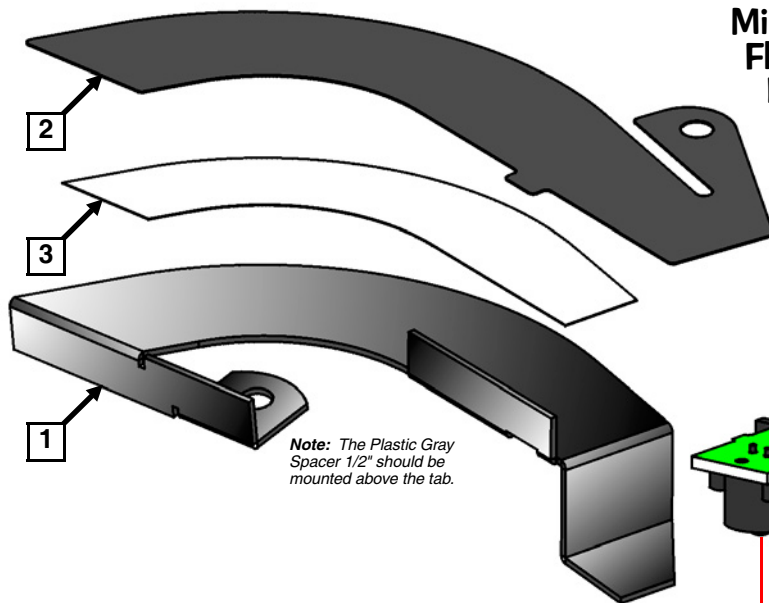

Note: The Plastic Gray Spacer 1/2" should be mounted above the tab.



Mini-Playfield Steel Shooter Ramp & Flap Assembly and OPTO Assembly Individual Parts Only (Items 1-6)

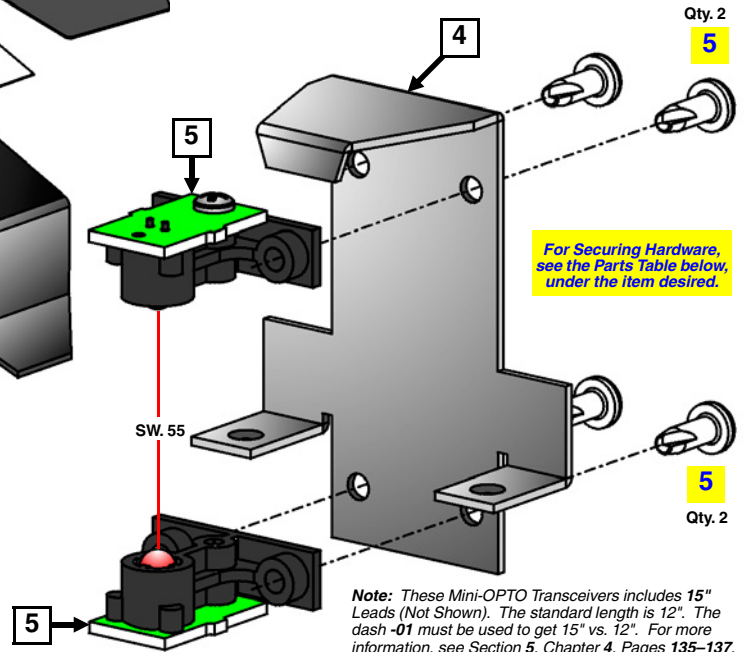

For Securing Hardware, see the Parts Table below, under the item desired.

Note: These Mini-OPTO Transceivers includes 15" Leads (Not Shown). The standard length is 12". The dash -01 must be used to get 15" vs. 12". For more information, see Section 5, Chapter 4, Pages 135-137.

Nr.	MINI-SHOOTER PARTS	QTY.	SPI PART Nr.	Nr.	MINI-SHOOTER PARTS	QTY.	SPI PART Nr.
1	Mini-Shooter Ramp Item 1 is secured to the playfield by: #6 X 1" SHWH (Qty. 1) (234-5005-00) and Spacer Gray 1/2" X 3/8" (Qty. 1) (254-5000-01) (ASM. REF. 511-5056-00, Items 1-3 ONLY)	1	535-9921-00	4	Bracket, OPTO Mounting (Shooter) Item 4 is secured below the playfield by: #8 X 1/2" SHWH AB (Zc.) (Qty. 4) (234-5101-00)	1	535-9976-00
2	Mini-Ramp Flap	1	535-9924-01	5	Mini OPTO Transceiver PCB Asm. Item 5 is secured to Item 1 by: #6 X 3/8" PPH (Zinc) Type-25 (Qty. 2/per) (237-5880-00) (ASM. REF. 511-5012-00, Items 4-5 ONLY)	2	500-6775-01
3	Tape, Double-Side (Die-Cut) Item 2 is secured to Item 1 by Item 3 and secured to the playfield by: #6 X 3/8" HWH Screw (Qty. 1) (234-5000-00)	1	000-0667-00	6	Steel Mini-Pinball (5/8" ø)	1	260-5002-00

Mini-Playfield Plastic Ramp Assembly, Individual Parts Only (Items 1-4)

Nr.	MINI-PLASTIC RAMP PARTS	QTY.	SPI PART Nr.	Nr.	MINI-PLASTIC RAMP PARTS	QTY.	SPI PART Nr.
1	Plastic Ramp, Mini-Pinball (No Parts)	1	545-6193-00	4	Kit: Plastic (incl. -22 Ramp Cover)	1	803-5000-A5
Item 1 is secured @ Left by: Cotter Pin (1/16" ø X 1/2" Long (Zinc)) (Qty. 1) (251-5006-00) (ASM. REF. 511-5011-00-A5, Items 1-3 ONLY)				Note: Individual Plastics (830-6074-XX & 830-6075-XX) are not available individually, ordering of kit is required.			
2	Mini OPTO Transceiver PCB Asm.	2	500-6775-01	Item 4 is secured to Item 1 @ Right by: #8-32 X 3/8" PPH MS (Sems) (Qty. 1) (232-5301-00) and @ Left Front by: Existing hardware of Item 2.			
Item 2 is secured to Item 1 by: #6 X 3/8" PPH (Zinc) Type-25 (Qty. 2/per) (237-5880-00)							
3	Ramp Flap	1	535-9929-00				
Item 3 is secured to the playfield by: Mini-Post Short MS // #10-32 .875" Thread (example shown on Page 54) (Qty. 2) (530-5749-00), #10 Washer (7/32" I.D. X 1/2" O.D. X 1/16") (Qty. 1/per) (242-5003-00), #10 Washer (Qty. 1/per) (242-5073-01), #10-32 Nylon Stop Nut (Qty. 1/per) (240-5203-00) and Rubber Ring White 3/8" O.D. (Qty. 1/per) (545-5348-69)							

For Securing Hardware, see the Parts Table below, under the item desired.

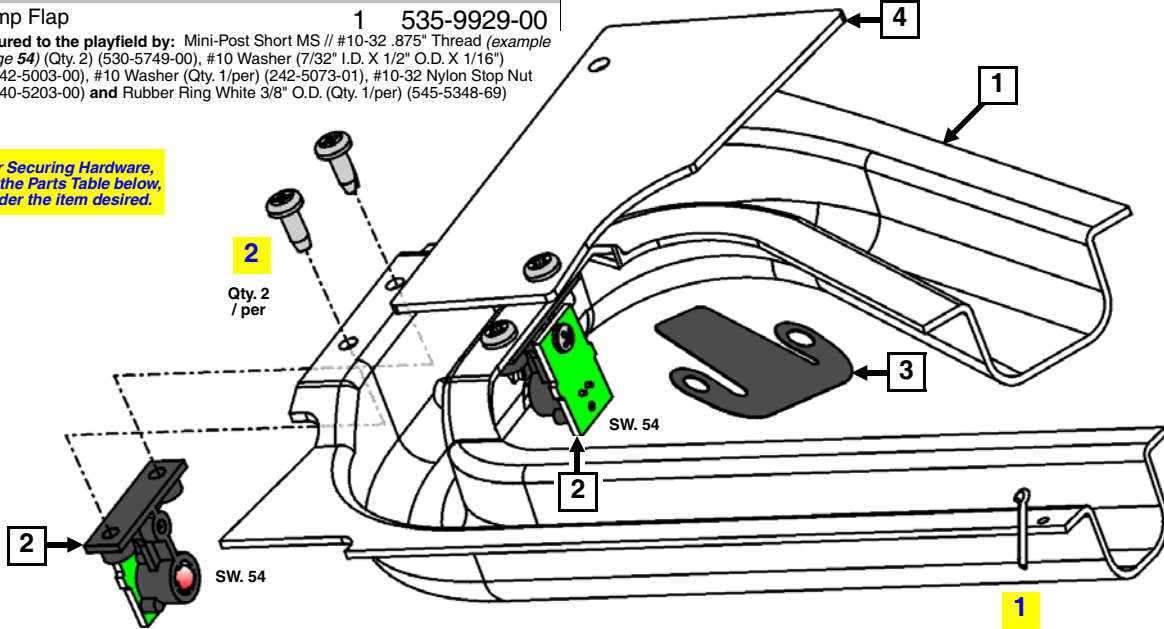

Mini-Pinball Plastic Enclosure Assembly, 510-5011-00-A5 (Items 1-4)

Nr.	ENCLOSURE PARTS	QTY.	SPI PART Nr.
1®	Kit: Plastic (incl. -01 - -06 + -13)	1	803-5001-A5
Note: Individual Plastics (830-6084-XX + 830-6075-63) are available unassembled. Use above part number 803-5001-A5. To order it assembled use part number 510-5011-00-A5.			

Take Note:

® "R" indicates Item noted is secured with rivet(s) as listed.

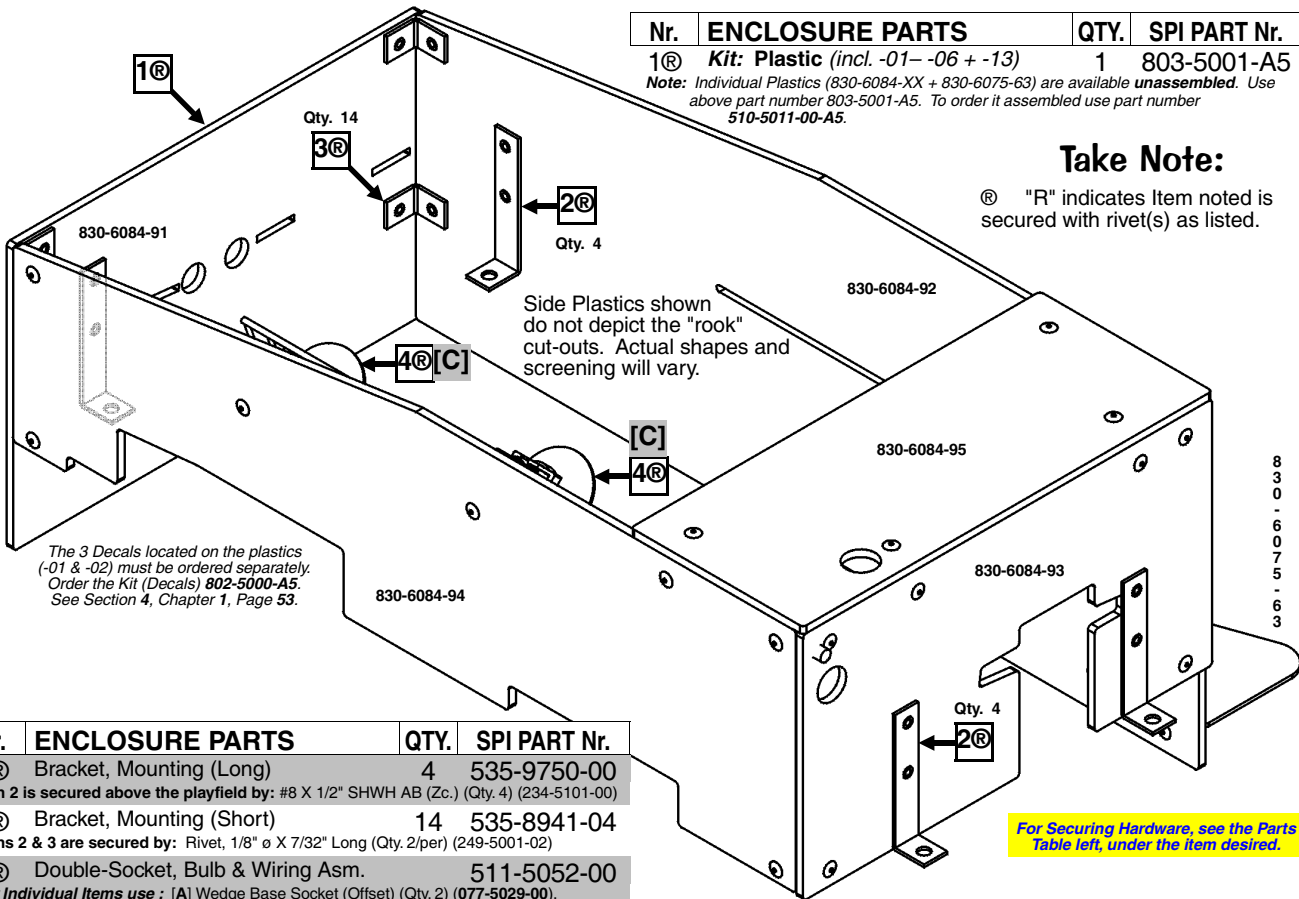

The 3 Decals located on the plastics (-01 & -02) must be ordered separately. Order the Kit (Decals) 802-5000-A5. See Section 4, Chapter 1, Page 53.

Nr.	ENCLOSURE PARTS	QTY.	SPI PART Nr.
2®	Bracket, Mounting (Long)	4	535-9750-00
Item 2 is secured above the playfield by: #8 X 1/2" SHWH AB (Zc.) (Qty. 4) (234-5101-00)			
3®	Bracket, Mounting (Short)	14	535-8941-04
Items 2 & 3 are secured by: Rivet, 1/8" ø X 7/32" Long (Qty. 2/per) (249-5001-02)			
4®	Double-Socket, Bulb & Wiring Asm.		511-5052-00
For Individual Items use : [A] Wedge Base Socket (Offset) (Qty. 2) (077-5029-00), [B] #555 Wedge Base Bulb (Clear) (Qty. 2) (165-5002-00), [C] Light Reflector (Silver) (Qty. 2) (545-5409-01) For Actual Size views, see Section 4, Chapter 1, Page 64.			

For Securing Hardware, see the Parts Table left, under the item desired.

Schematics, Wiring & Printed Circuit Boards

Table of Contents
for Section 5

Chapter 1, Backbox Wiring	96 – 98
▶ Table of Contents for Section 5.....	95
▶ Coils Detailed Chart Table.....	96
▶ Backbox I/O Power Driver Board Detailed Wiring Diagram.....	97
▶ Backbox Board Layout Wiring Diagram.....	98
Chapter 2, Playfield Wiring	99 – 103
▶ General Illumination Circuit Detailed Wiring Diagram.....	99
▶ Playfield Switch Wiring Diagram.....	100
▶ Playfield Lamp Wiring Diagram.....	101
▶ Playfield Terminal Strips, Fuses & Misc. Wiring Descriptions & Locations.....	102
▶ 3-Flipper Circuit Wiring Diagram.....	103
Chapter 3, Cabinet and Coin Door Wiring	105 – 108
▶ Transformer Power Wiring Diagram.....	105
▶ Cabinet Wiring Diagram.....	106
▶ Coin Door Wiring Diagram.....	107
Chapter 4, Printed Circuit Boards (PCBs)	109 – 138
▶ Trough Up-Kicker Dual OPTO PCBs (515-0173-00 & 515-0174-00) Theory of Operation & Schematic..... (Top)	109
▷ Trough Up-Kicker Dual OPTO PCBs (515-0173-00 & 515-0174-00) Component Layout & Parts..... (Bot)	109
▶ OPTO Troubleshooting..... (Top)	110
▷ Trough Dual OPTO PCBs Alignment / Tests for LED1 & LED2.....	110-111
▶ I/O Power Driver PCB S.A.M. System (520-5249-00) Schematic (Sheet 1 of 4).....	112-113
▶ I/O Power Driver PCB S.A.M. System (520-5249-00) Schematic (Sheet 2 of 4).....	114-115
▶ I/O Power Driver PCB S.A.M. System (520-5249-00) Schematic (Sheet 3 of 4).....	116-117
▶ I/O Power Driver PCB S.A.M. System (520-5249-00) Schematic (Sheet 4 of 4).....	118-119
▷ I/O Power Driver PCB S.A.M. System (520-5249-00) Component Layout.....	120
▷ I/O Power Driver PCB S.A.M. System (520-5249-00) Parts.....	121
▶ CPU / Sound PCB S.A.M. System (520-5246-00) Schematic (Sheet 1 of 5).....	122-123
▶ CPU / Sound PCB S.A.M. System (520-5246-00) Schematic (Sheet 2 of 5).....	124-125
▶ CPU / Sound PCB S.A.M. System (520-5246-00) Schematic (Sheet 3 of 5).....	126-127
▶ CPU / Sound PCB S.A.M. System (520-5246-00) Schematic (Sheet 4 of 5).....	128-129
▶ CPU / Sound PCB S.A.M. System (520-5246-00) Schematic (Sheet 5 of 5).....	130-131
▷ CPU / Sound PCB S.A.M. System (520-5246-00) Component Layout.....	132
▷ CPU / Sound PCB S.A.M. System (520-5246-00) Parts.....	132-133
▶ Display Power Supply PCB (520-5138-00) Schematic.....	134
▷ Display Power Supply PCB (520-5138-00) Component Layout & Parts.....	134
▶ Playfield Switches OPTO Transceiver PCBs (500-6755-00) Schematic..... (Top)	135
▶ Playfield OPTO Transmitter / Receiver Amplifier PCB (520-5239-01) Schematic..... (Bot)	135
▷ Playfield OPTO Transmitter / Receiver Amplifier PCB (520-5239-01) Component Layout & Parts..... (Top)	136
▷ Playfield OPTO Transmitter / Receiver Amplifier PCB (520-5239-01) Wiring..... (Bot)	136
▷ Playfield OPTO Transmitter / Receiver Amplifier PCB (520-5239-01) Locations.....	137
▶ OPTO Interrupter PCB (520-5252-04) Schematic (4-Bank Drop Target).....	138
▷ OPTO Interrupter PCB (520-5252-04) Component Layout & Parts (4-Bank Drop Target)..... (Top)	139
▶ OPTO Interrupter PCB (520-5252-01) Schematic (1-Bank Drop Target)..... (Bot)	139
▷ OPTO Interrupter PCB (520-5252-01) Component Layout & Parts (1-Bank Drop Target)..... (Bot)	139
▶ Mini-Playfield Lamp PCB (520-5264-00) Schematic.....	140
▷ Mini-Playfield Lamp PCB (511-5046-00) Component Layout & Parts.....	141
▶ Stepper Motor Controller PCB (520-5261-00) Schematic..... (Top)	142
▷ Stepper Motor Controller PCB (511-5045-00) Component Layout & Parts..... (Bot)	142
▶ Auxiliary (3X Transistor) Driver PCB (in Backbox) with the Coin/Ticket Meter and Ticket Disp. Wiring Diagram.....	143
▶ Auxiliary (3X Transistor) Driver PCB Schematic..... (Top)	144
▷ Auxiliary (3X Transistor) Driver PCB Component Layout..... (Bot)	144

Use the below **Coils Detailed Chart Table** in conjunction with **Sec. 5, Chp. 1, Backbox I/O Power Driver Board Detailed Wiring Diagram (I/O Board Connectors J6, J7, J8 & J9) and Backbox Board Layout Wiring Diagram:**

High Current Coils Group 1		Drive Transistor	Driver Output Board	Power Line Color	Power Line Connection	Power Voltage	Drive Transistor Control Line Color	D.T. Control Line Connect	Coil GA-Turn or Bulb Type
#1	TROUGH UP-KICKER	Q1	▲ I/O Power Driver ▼	YEL-VIO	J10-P9/10	50v DC	BRN-BLK	J8-P1	26-1200 ∪ 090-5044-ND
#2	AUTO LAUNCH	Q2		YEL-VIO	J10-P9/10	50v DC	BRN-RED	J8-P3	24-940 ∪ 090-5036-ND
#3	4-BANK DROP TARGET	Q3		YEL-VIO	J10-P9/10	50v DC	BRN-ORG	J8-P4	24-940 ∪ 090-5036-ND
#4	BALL SAVER DOWN (PINOCCHIO POST)	Q4		YEL-VIO	J10-P9/10	50v DC	BRN-YEL	J8-P5	32-1800 ∪ 090-5031-00-ND
#5	MERLIN EJECT (VUK)	Q5		YEL-VIO	J10-P9/10	50v DC	BRN-GRN	J8-P6	27-1500 ∪ 090-5004-ND
#6	1-BANK DROP TARGET	Q6		YEL-VIO	J10-P9/10	50v DC	BRN-BLU	J8-P7	24-940 ∪ 090-5036-ND
#7	LEFT SLINGSHOT	Q7		YEL-VIO	J10-P9/10	50v DC	BRN-VIO	J8-P8	27-1500 ∪ 090-5004-ND
#8	RIGHT SLINGSHOT	Q8		YEL-VIO	J10-P9/10	50v DC	BRN-GRY	J8-P9	27-1500 ∪ 090-5004-ND

High Current Coils Group 2		Drive Transistor	Driver Output Board	Power Line Color	Power Line Connection	Power Voltage	Drive Transistor Control Line Color	D.T. Control Line Connect	Coil GA-Turn or Bulb Type
#9	BOTTOM BUMPER	Q9	▲ I/O Power Driver ▼	YEL-VIO	J10-P9/10	50v DC	BLU-BRN	J9-P1	26-1200 ∪ 090-5044-ND
#10	RIGHT BUMPER	Q10		YEL-VIO	J10-P9/10	50v DC	BLU-RED	J9-P2	26-1200 ∪ 090-5044-ND
#11	TOP BUMPER	Q11		YEL-VIO	J10-P9/10	50v DC	BLU-ORG	J9-P4	26-1200 ∪ 090-5044-ND
#12	BALL SAVER UP (PINOCCHIO POST)	Q12		YEL-VIO	J10-P9/10	50v DC	BLU-YEL	J9-P5	26-1200 ∪ 090-5044-ND
#13	SWAMP EJECT (SCOOP)	Q13		YEL-VIO	J10-P9/10	50v DC	BLU-GRN	J9-P6	23-800 ∪ 090-5001-ND
#14	UPPER LEFT FLIPPER	Q14		BLU-YEL-3A Fuse-RED-YEL	J10-P6/7	50v DC	BLU-BLK	J9-P7	23-1500 ∪ 090-5062-ND
#15	LEFT FLIPPER (50v RED/YEL)	Q15		GRY-YEL-3A Fuse-RED-YEL	J10-P6/7	50v DC	ORG-GRY	J9-P8	23-1100 ∪ 090-5030-ND
#16	RIGHT FLIPPER (50v RED/YEL)	Q16		BLU-YEL-3A Fuse-RED-YEL	J10-P6/7	50v DC	ORG-VIO	J9-P9	23-1100 ∪ 090-5030-ND

Low Current Coils Group 1		Drive Transistor	Driver Output Board	Power Line Color	Power Line Connection	Power Voltage	Drive Transistor Control Line Color	D.T. Control Line Connect	Coil GA-Turn or Bulb Type
#17	LEFT MINI FLIPPER (UPR. P/F)	Q17	▲ I/O Power Driver ▼	BROWN	J7-P1	20v DC	VIO-BRN	J7-P2	27-950 ∪ 090-5046-01-ND
#18	RIGHT MINI FLIPPER (UPR. P/F)	Q18		BROWN	J7-P1	20v DC	VIO-RED	J7-P3	27-950 ∪ 090-5046-01-ND
#19	CASTLE GUARD (LEFT RAMP GATE)	Q19		BROWN	J7-P1	20v DC	VIO-ORG	J7-P4	32-1250 ∪ 515-6916-01-ND
#20	DONKEY MOTOR DRIVE	Q20		RED	J16-P4/8	5v DC	VIO-WHT	J7-P6	Strp. Motor 511-5043-00
#21	MINI TROUGH (SHOOTER UPR. P/F)	Q21		BROWN	J7-P1	20v DC	VIO-GRN	J7-P7	27-950 ∪ 090-5046-01-ND
#22	NOT USED	Q22					VIO-BLU	J7-P8	
#23	FLASH: LOWER LEFT	Q23		ORANGE	J6-P10	20v DC	VIO-BLK	J7-P9	#89 Bulb 165-5000-89
#24	OPTIONAL COIL	Q24		RED	J16-P4>8	5v DC	VIO-GRY	J7-P10	Opt. 5v

Diode On Terminal Strip (if noted)

Low Current Coils Group 2		Drive Transistor	Driver Output Board	Power Line Color	Power Line Connection	Power Voltage	Drive Transistor Control Line Color	D.T. Control Line Connect	Coil GA-Turn or Bulb Type
#25	FLASH: BACK(PANEL) LEFT	Q25	▲ I/O Power Driver ▼	ORANGE	J6-P10	20v DC	BLK-BRN	J6-P1	#89 Bulb 165-5000-89
#26	FLASH: BACK(PANEL) CENTER	Q26		ORANGE	J6-P10	20v DC	BLK-RED	J6-P2	#89 Bulb 165-5000-89
#27	FLASH: BACK(PANEL) RIGHT	Q27		ORANGE	J6-P10	20v DC	BLK-ORG	J6-P3	#89 Bulb 165-5000-89
#28	FLASH: (MAGIC) MIRROR	Q28		ORANGE	J6-P10	20v DC	BLK-YEL	J6-P4	#89 Bulb 165-5000-89
#29	FLASH: FIONA	Q29		ORANGE	J6-P10	20v DC	BLK-GRN	J6-P5	#89 Bulb 165-5000-89
#30	FLASH: RIGHT ORBIT (SPINNER)	Q30		ORANGE	J6-P10	20v DC	BLK-BLU	J6-P6	#89 Bulb 165-5000-89
#31	FLASH: POPS (BUMPERS)	Q31		ORANGE	J6-P10	20v DC	BLK-VIO	J6-P7	#89 Bulb 165-5000-89
#32	FLASH: LOWER RIGHT	Q32		ORANGE	J6-P10	20v DC	BLK-GRY	J6-P8	#89 Bulb 165-5000-89

Note: In Test Flash Lamps Menu ("Flash" Icon), Flashers tested are all Flash Lamps located between Q1-Q32 (This Game: **Q23, Q25-Q32**)

∪ Coil Note: ∪ -ND means 'No Diode'. -00B or -00T can be used for coil replacements, but the diode must be removed. Call for more info.

Sec. 5: Schematics...



Backbox I/O Power Driver Board (Coils Q1-Q32) Detailed Wiring Diagram

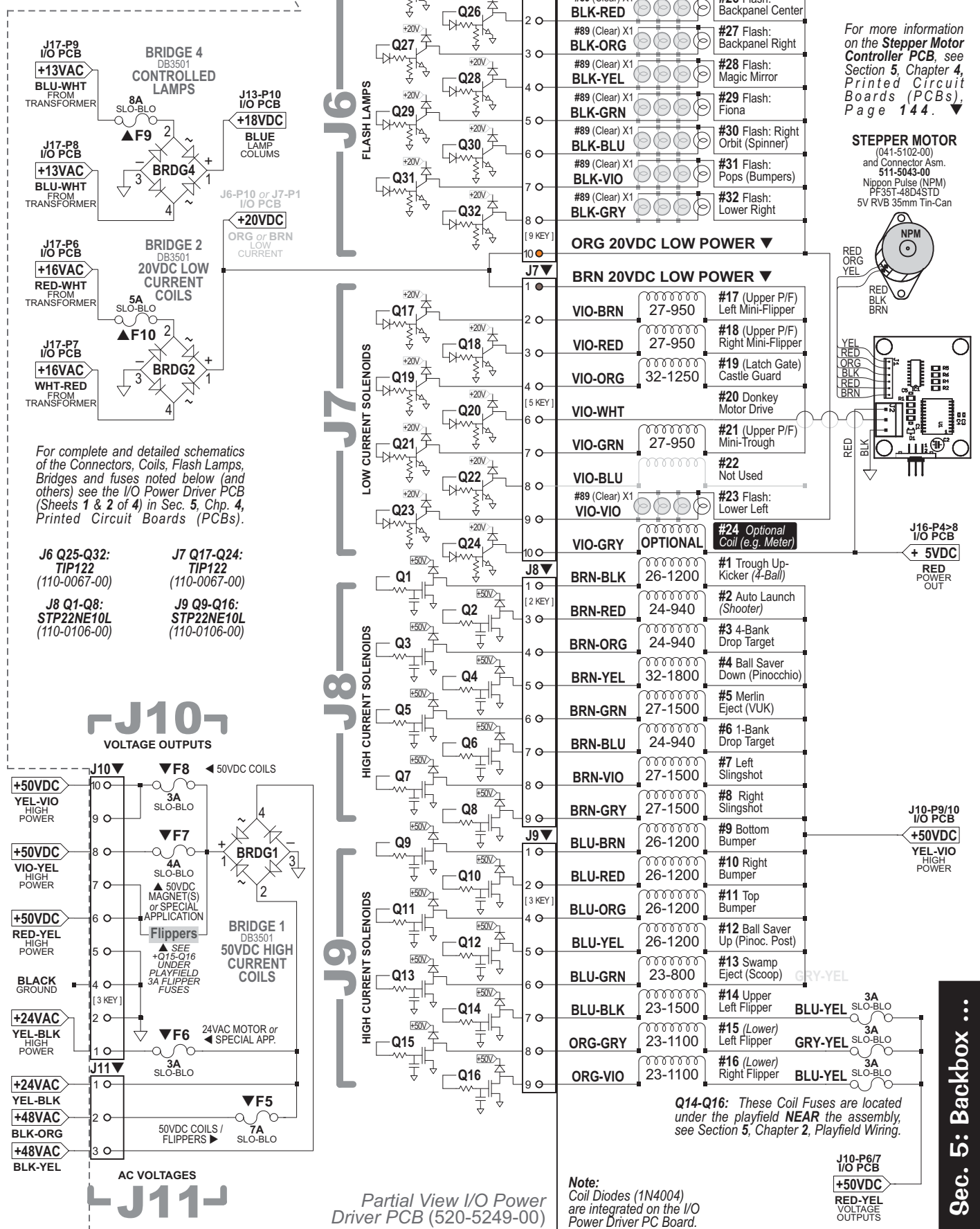

For more information on the Stepper Motor Controller PCB, see Section 5, Chapter 4, Printed Circuit Boards (PCBs), Page 144.

For complete and detailed schematics of the Connectors, Coils, Flash Lamps, Bridges and fuses noted below (and others) see the I/O Power Driver PCB (Sheets 1 & 2 of 4) in Sec. 5, Chp. 4, Printed Circuit Boards (PCBs).

- J6 Q25-Q32: TIP122 (110-0067-00)
- J7 Q17-Q24: TIP122 (110-0067-00)
- J8 Q1-Q8: STP22NE10L (110-0106-00)
- J9 Q9-Q16: STP22NE10L (110-0106-00)

Partial View I/O Power Driver PCB (520-5249-00)

Sec. 5: Backbox ...



Backbox Board Layout Wiring Diagram

- 128 X 32 Dot Matrix Display PCB (USA)** **520-5052-00**
- EURO ONLY RoHS** **Dot Matrix Pin-LED PCB** **520-5052-04**
- EURO ONLY RoHS** **Dot Matrix Pin-LED Bezel** **545-6281-00**
- Ribbon Cable, 14-Pin (32")** **036-5260-32**
- EURO ONLY RoHS** **LED Ribbon Cable Filter PCB** **520-5299-00**
- Display Cable (Wiring Harness)** **036-5454-01**
- FOR ALL PARTS IN TABLE, SEE SEC. 4, CHP. 1, SPEAKER PANEL PARTS, PG. 45.**

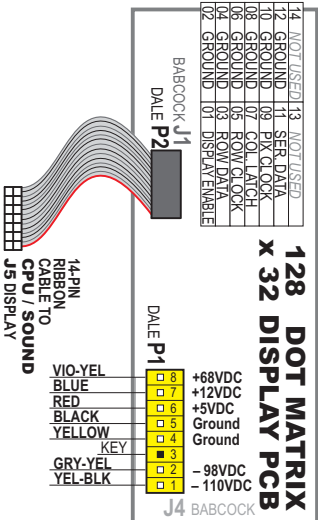

CN1 to Transformer (Cabinet)

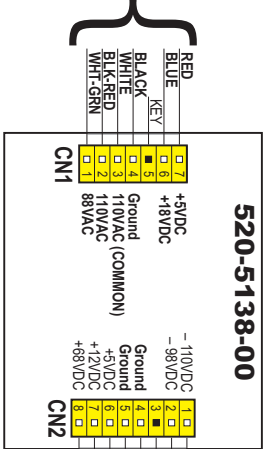

DISPLAY POWER SUPPLY PCB

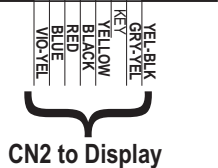

CN2 to Display

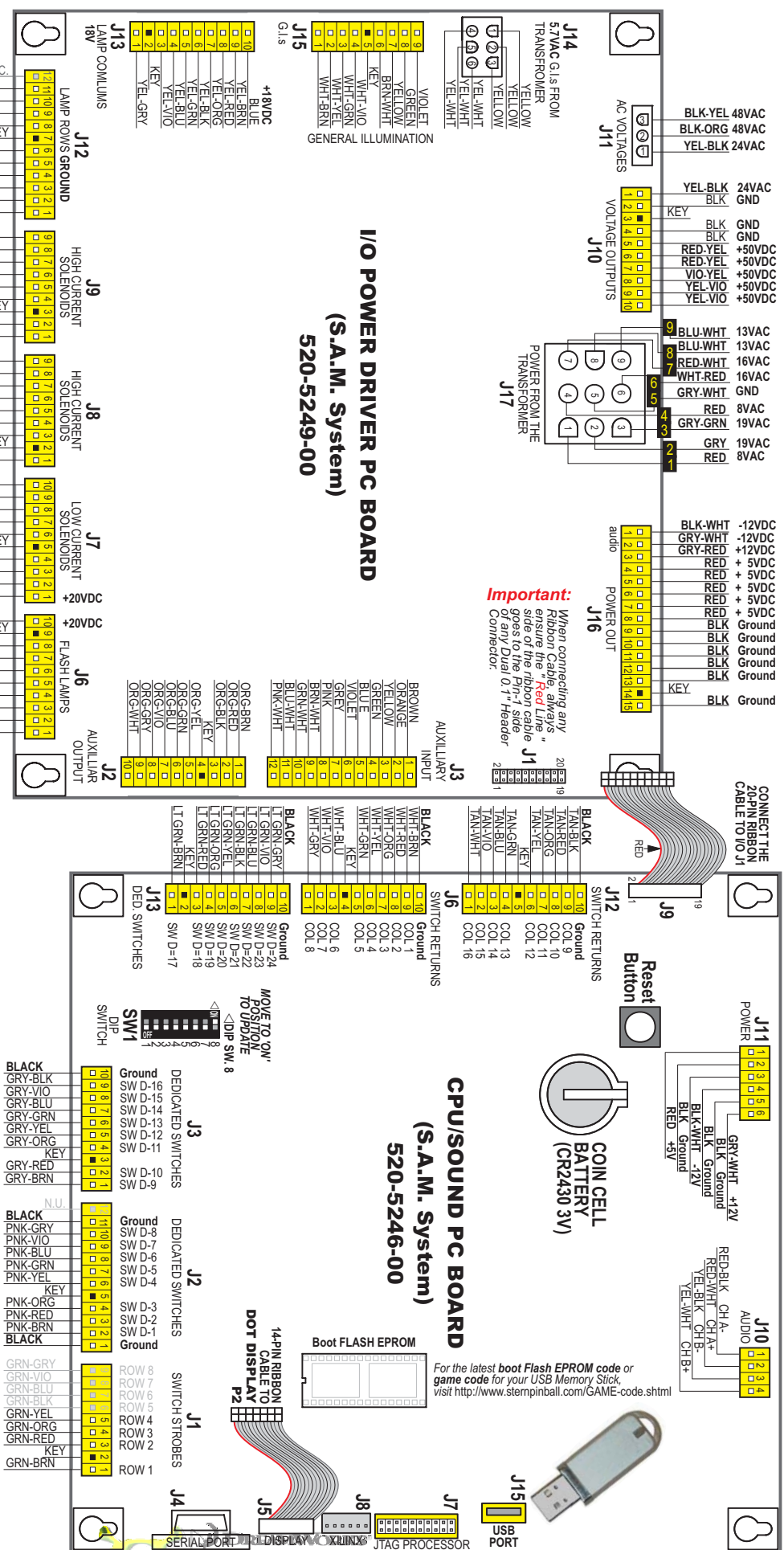

Playfield Wiring

General Illumination Circuit Detailed Wiring Diagram

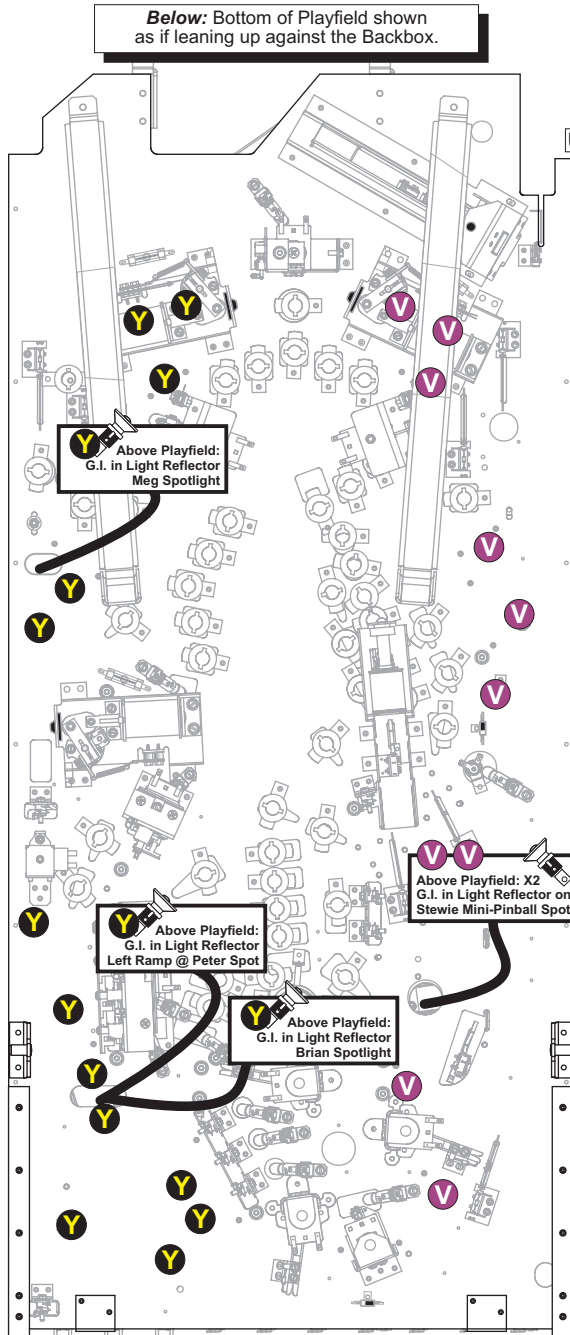

Below: Located at the top of the P/F, rear view of the Back Panel.

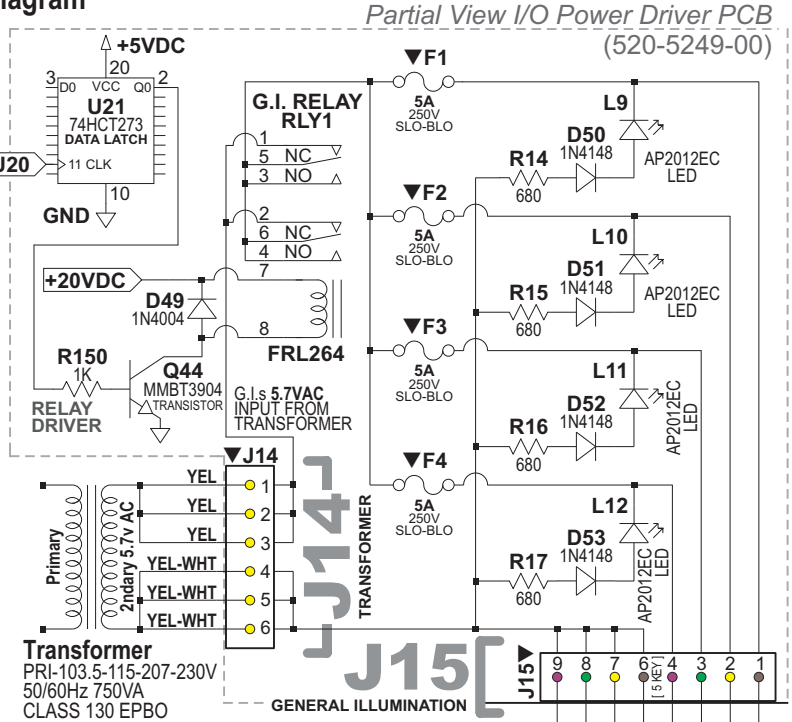

Transformer
 PRI-103.5-115-207-230V
 50/60Hz 750VA
 CLASS 130 EPBO

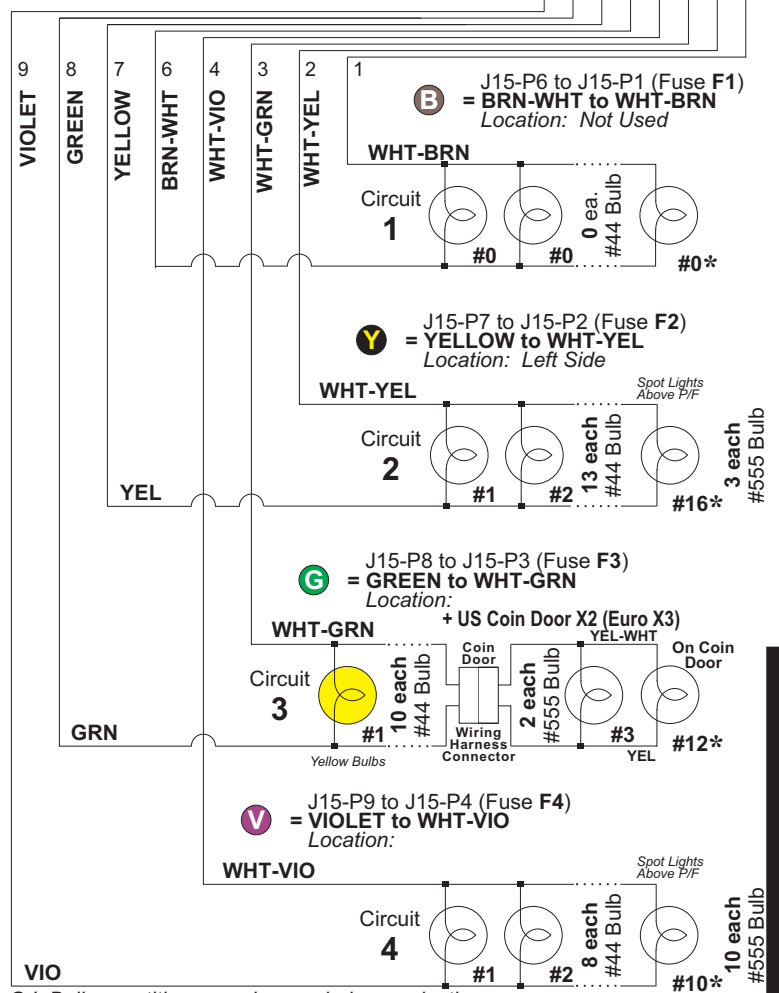

* G.I. Bulb quantities may change during production.

Sec. 5: Playfield ...

Playfield Switch Wiring Diagram



Please Note: Switch & Lamp Descriptions may differ slightly from that of the Dot Display due to space restraints.

Sec. 5: Playfield ...



Playfield Lamp Wiring Diagram

Please Note: Switch & Lamp Descriptions may differ slightly from that of the Dot Display due to space restraints.

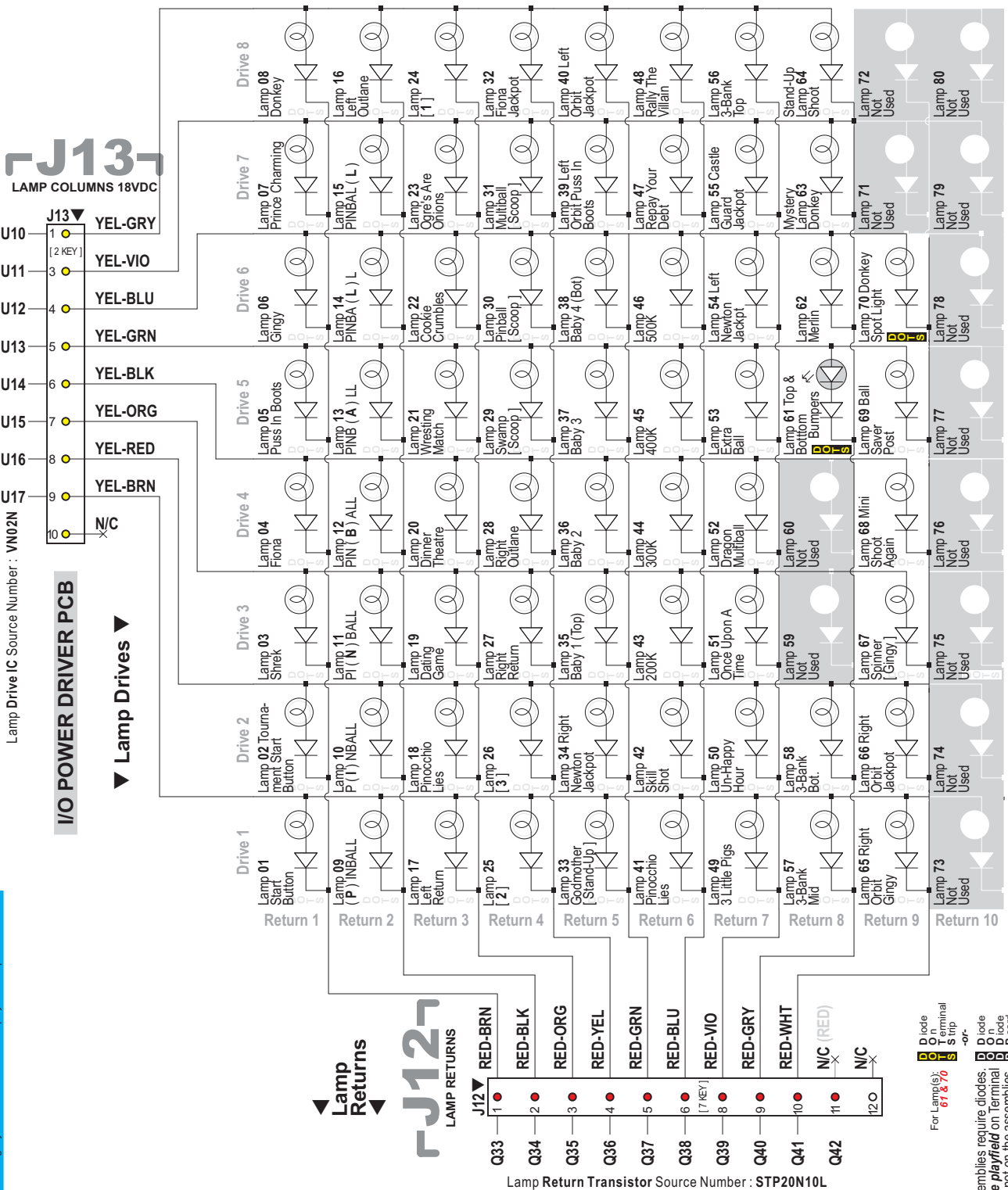

Note: All Switch, Lamp & Coil assemblies require diodes. Some diodes are located under the playfield on Terminal Strips or Diode Boards and not on the assemblies.

Sec. 5: Playfield ...

Playfield Terminal Strips, Fuses & Misc. Wiring Descriptions & Locations

Please Note: Terminal Strip(s), Diode Board(s) and/or Fuse Holder(s) locations shown, represent the general location (your game may differ slightly).

All fuses are rated:
3A 250v Slo-Blo
Do Not Over-Fuse

Bottom of Playfield shown as if leaning up against the Backbox.

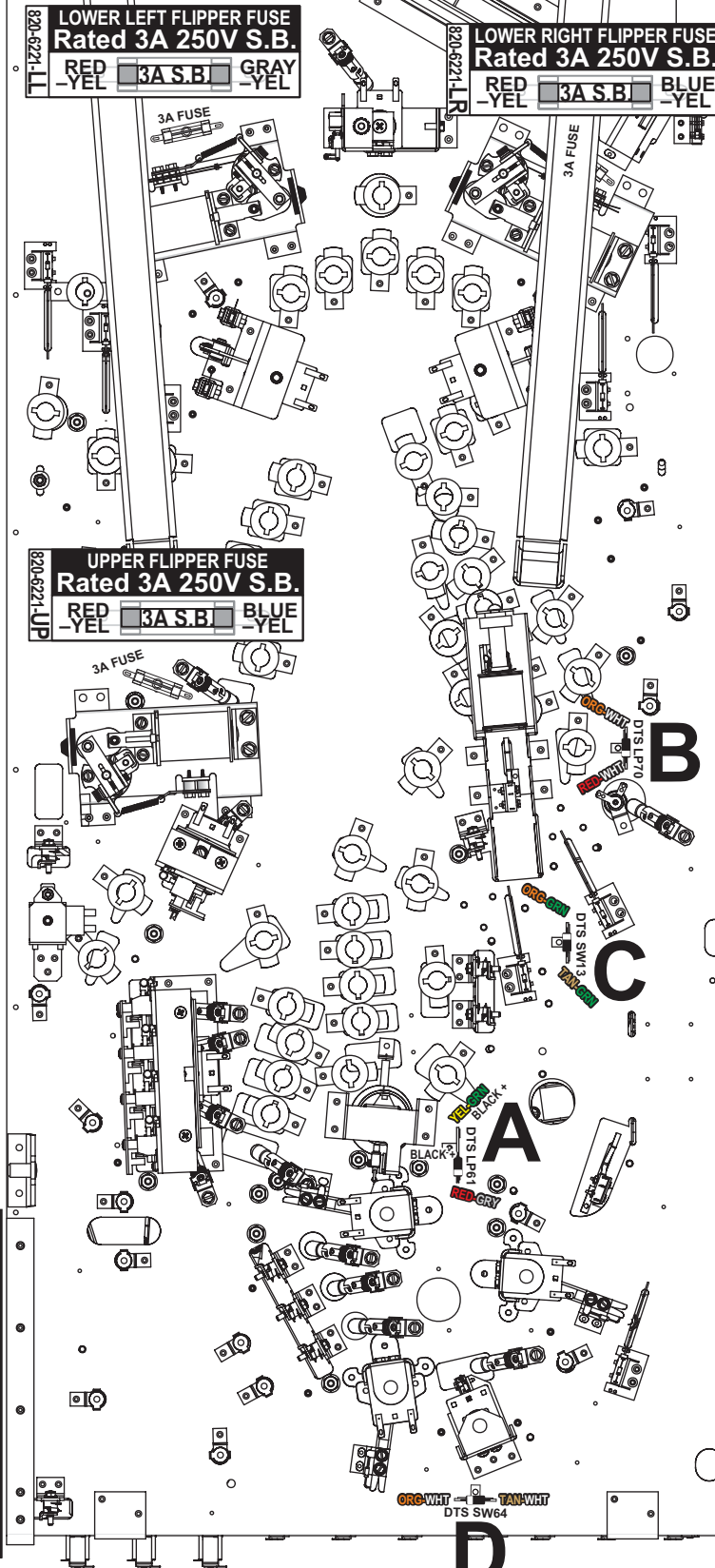

Explanation:

All Switches, Lamps & Coils require diodes. Coil diodes are located on the I/O Power Driver PCB (in Backbox). Some diodes from switches or lamps are moved onto Terminal Strips (**located under the playfield**). This is done where space constraints or excessive vibrations are present. The Switch & Lamp Matrix Grids also note which Switch or Lamp has a diode on a Terminal Strip, noted by **DOTS** (Diode On Terminal Strip).

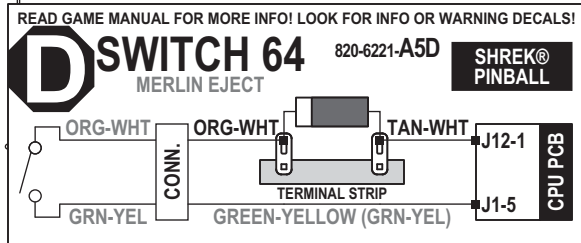
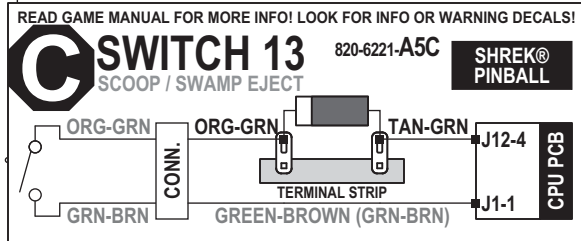
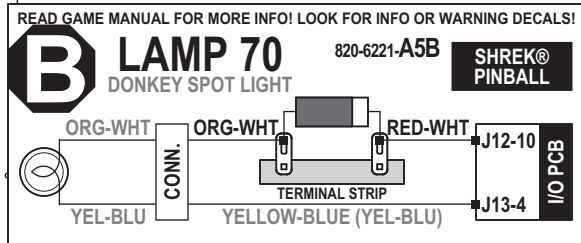
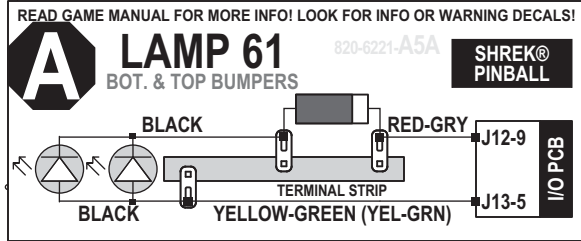

See Sec. 4, Chp. 1 (Pink Pages), Playfield Bottom – Misc. Parts and Brackets for Terminal Strips, Diodes, Fuses and Fuse Holders Part #s.



Sec. 5: Playfield ...



3- Flipper Circuit Wiring Diagram (Upper Mini-Playfield Flippers operate with lower button presses if programming allows.)

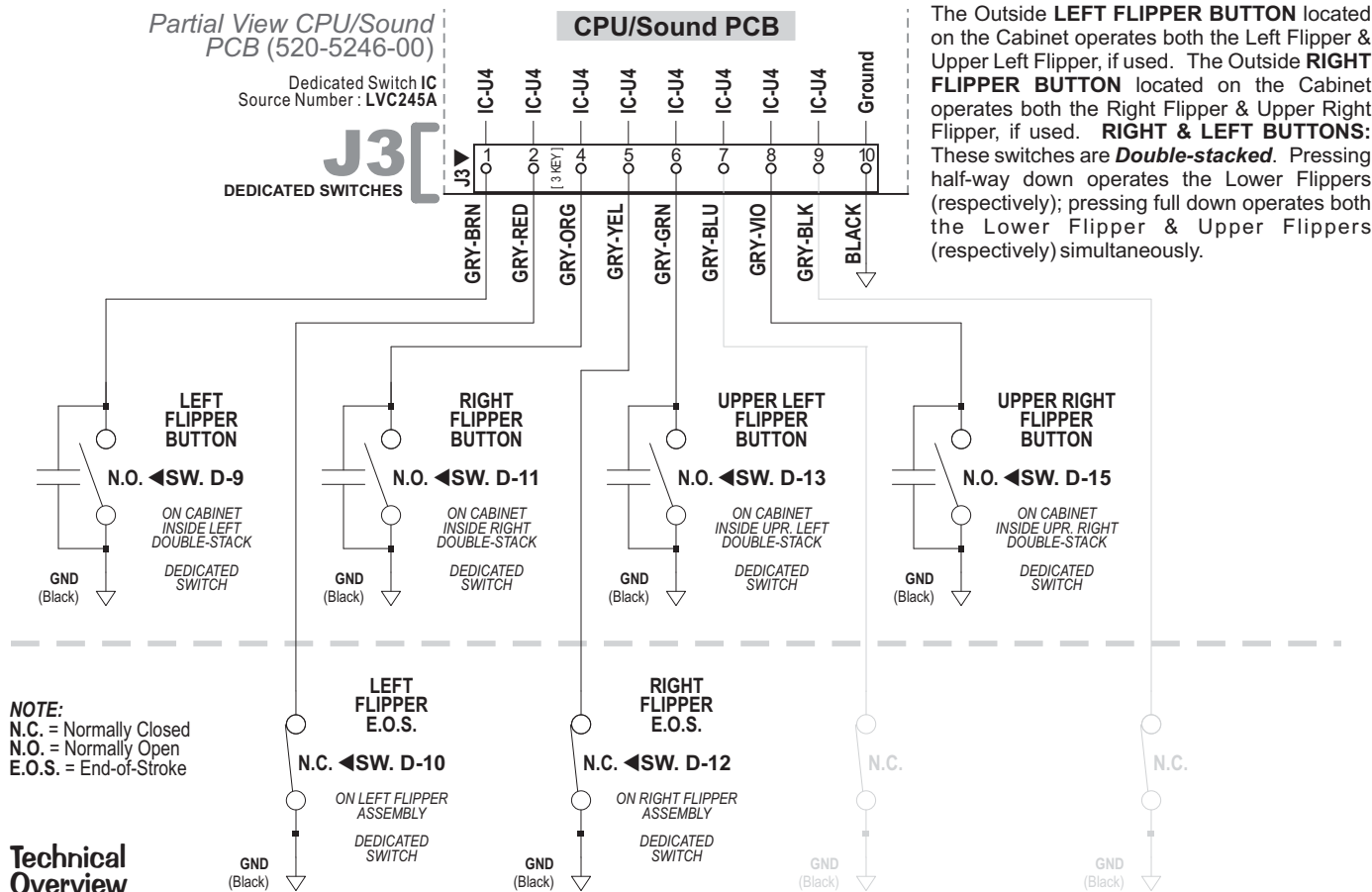

The Outside **LEFT FLIPPER BUTTON** located on the Cabinet operates both the Left Flipper & Upper Left Flipper, if used. The Outside **RIGHT FLIPPER BUTTON** located on the Cabinet operates both the Right Flipper & Upper Right Flipper, if used. **RIGHT & LEFT BUTTONS:** These switches are **Double-stacked**. Pressing half-way down operates the Lower Flippers (respectively); pressing full down operates both the Lower Flipper & Upper Flippers (respectively) simultaneously.

Our **Flipper System** uses one supply voltage (+50VDC) for both **kick & hold**. Once the **Game CPU** detects a Flipper Cabinet Switch closure (*during game play*) it applies a 40msec pulse to the gate of the Flipper Drive Transistor (STP22NE10L). If it continues to detect a Flipper Cabinet Switch closure (*the player holding the button in*) it will continue to pulse the flipper drive transistor 1msec every 12msecs for the duration of the hold cycle.

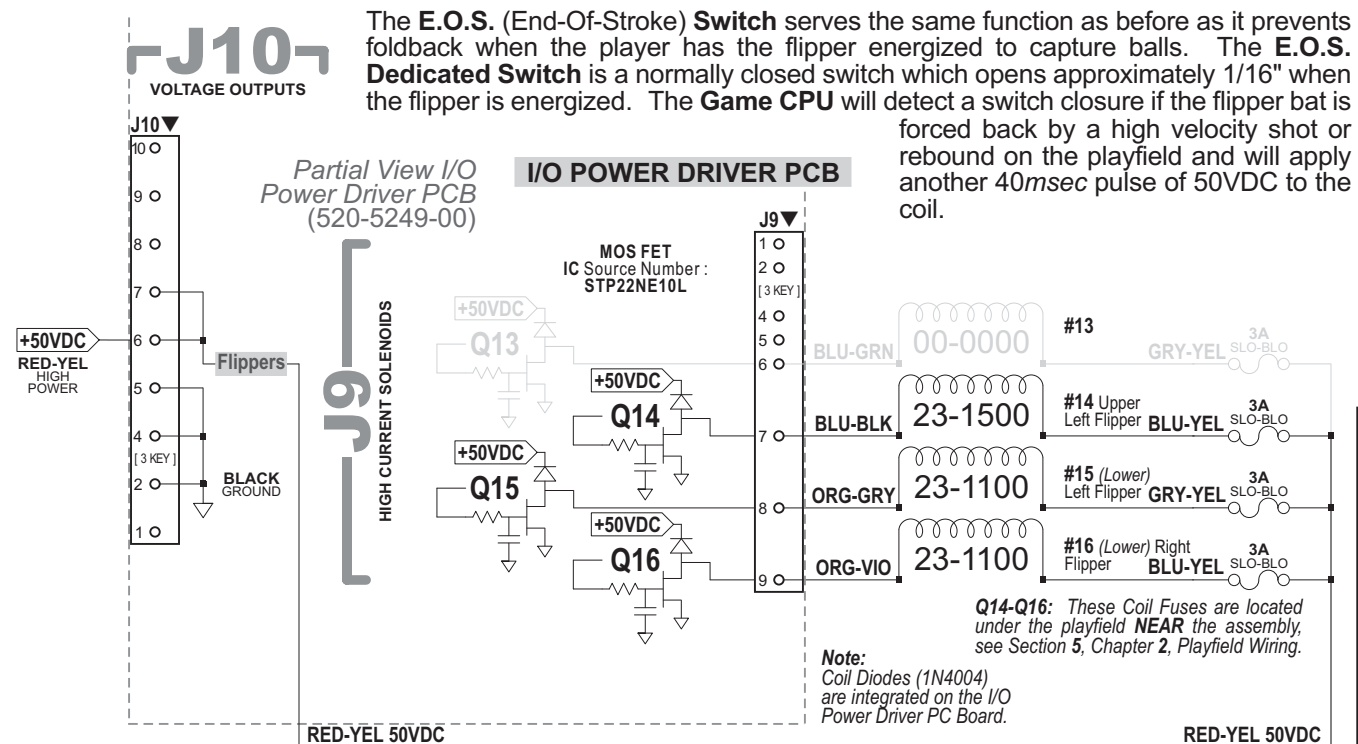



Cabinet and Coin Door Wiring

Transformer Power Wiring Diagram

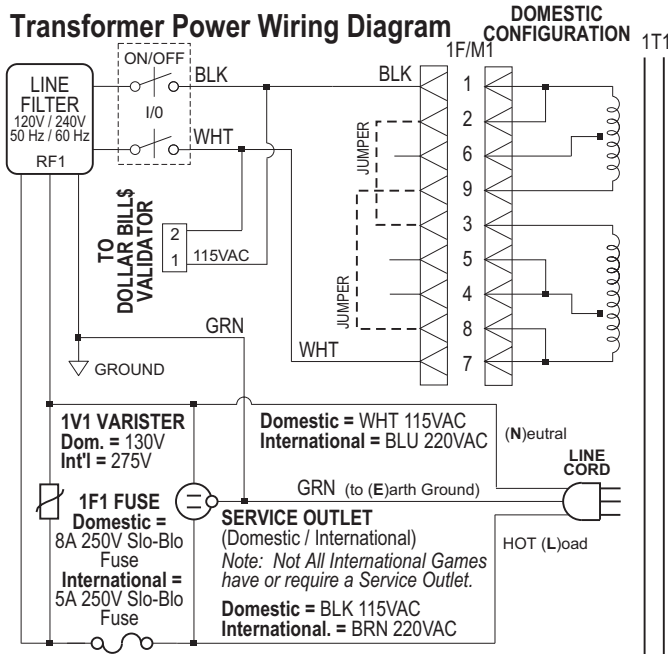

▼ Jumper Configurations for Voltage Variations ▼

N. AMERICA LINE VOLTAGE 110VAC / 120VAC

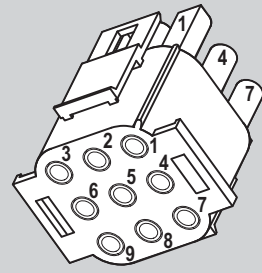
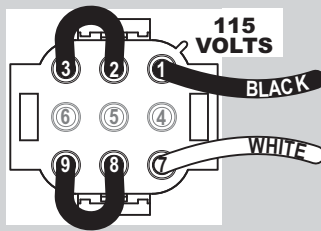

INTERNATIONAL or HIGH LINE VOLTAGE 230VAC / 218VAC / 206VAC

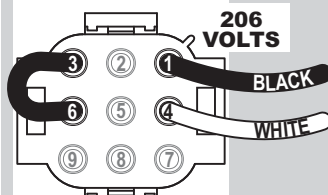
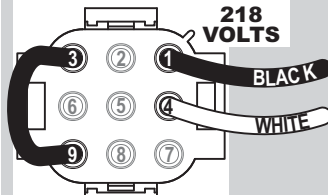
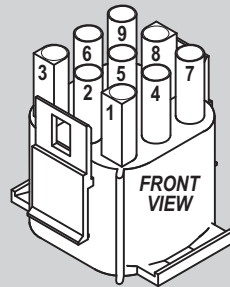
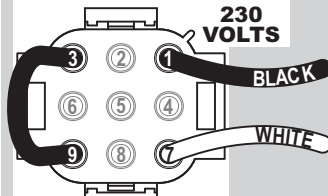

JAPAN or LOW LINE VOLTAGE 100VAC / 105VAC

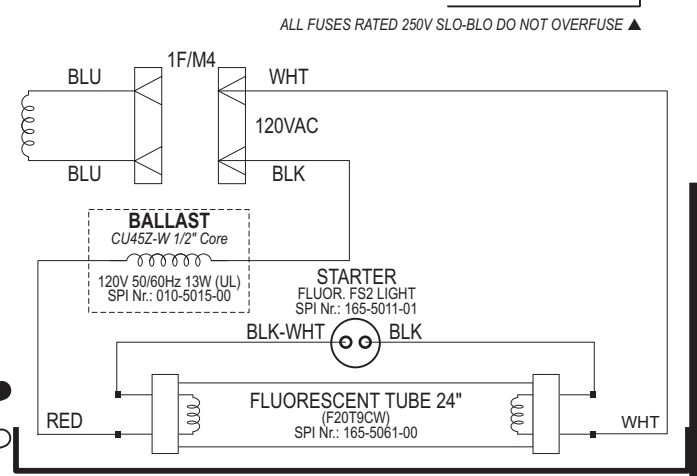
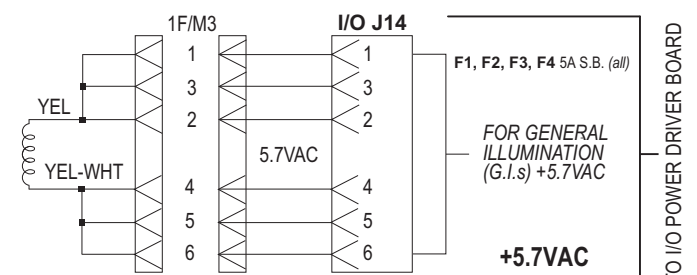
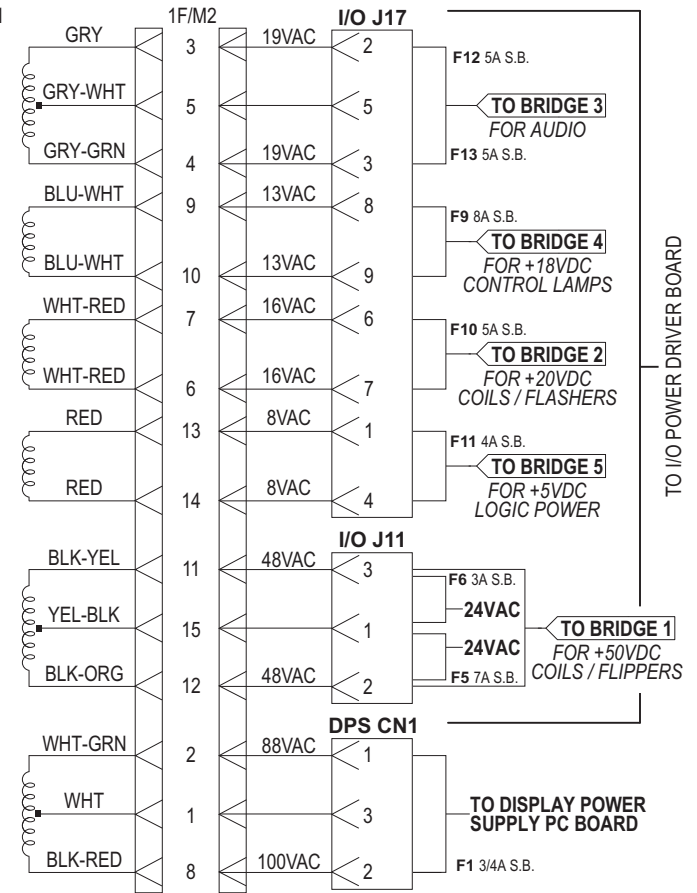
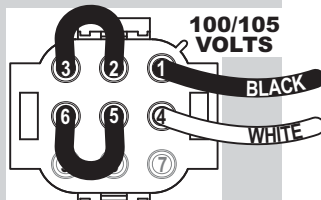

ALL FUSES RATED 250V SLO-BLO DO NOT OVERFUSE ▲

Cabinet Wiring Diagram

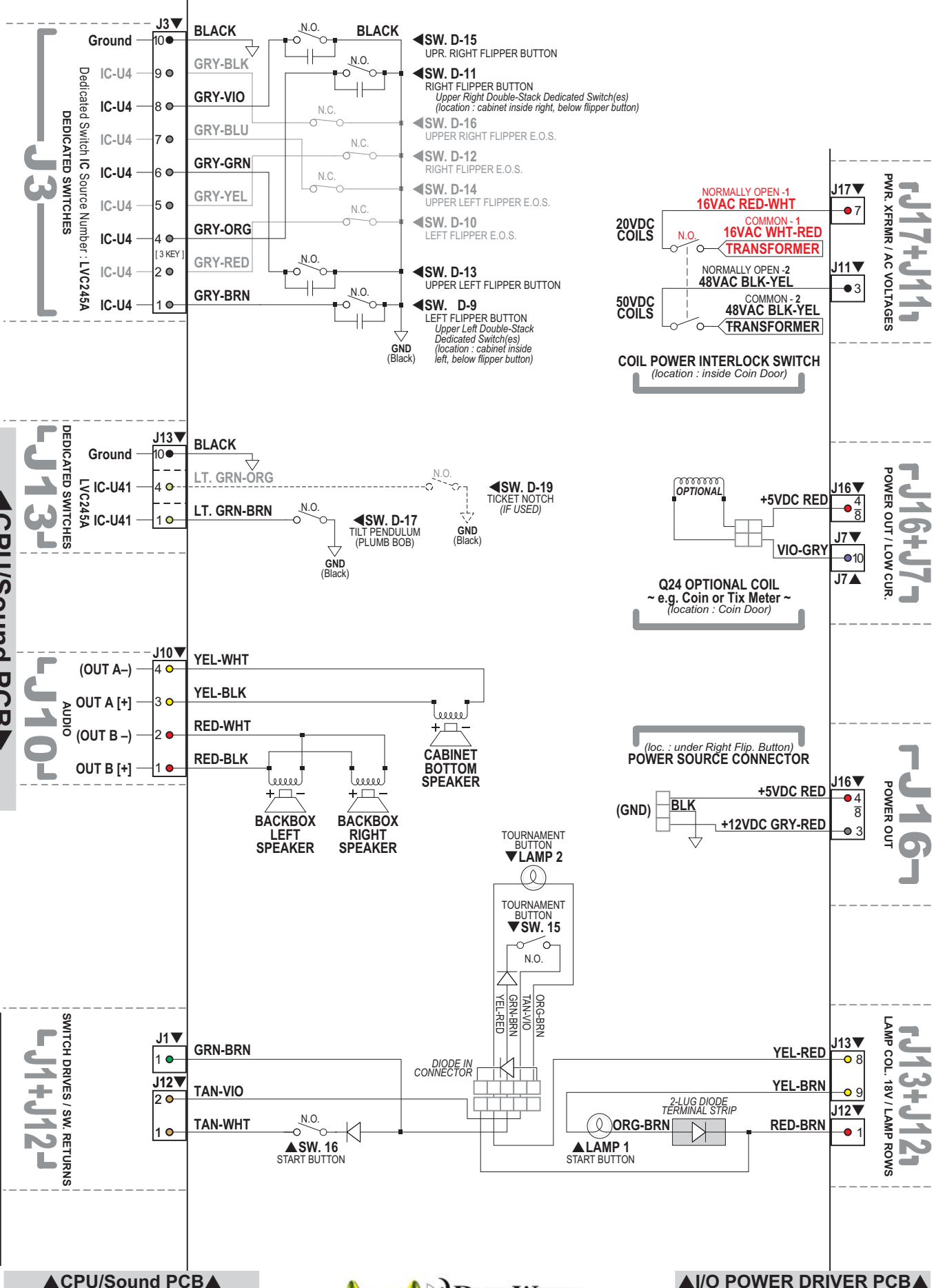

▲ CPU/Sound PCB ▲

▲ I/O POWER DRIVER PCB ▲



Coin Door Wiring Diagram

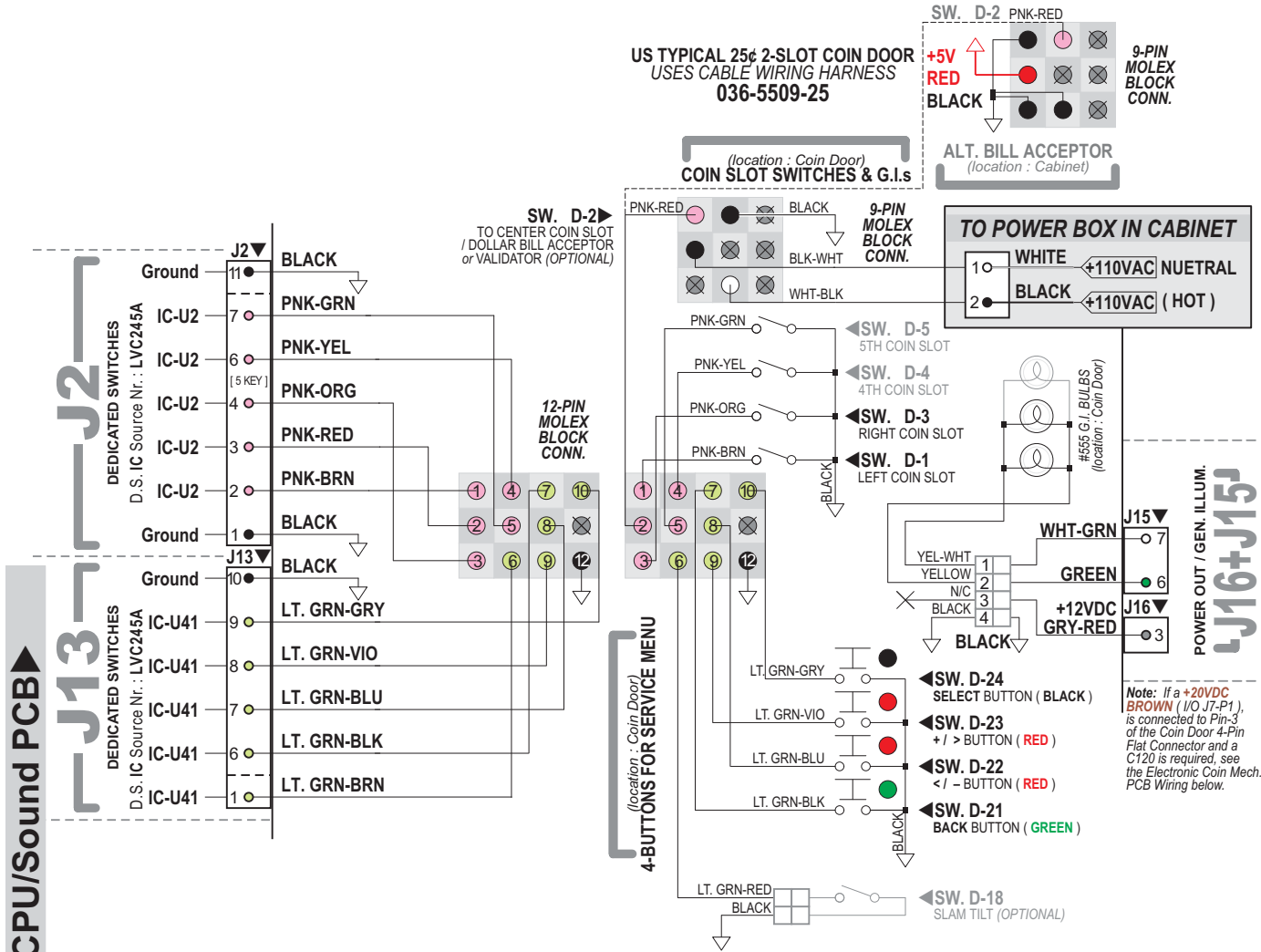

1-SLOT COIN DOOR WITH C120 CAPABILITIES (NO INTERFACE COIN MECH PCB REQUIRED)
USES CABLE WIRING HARNESS
036-5509-31A (+12VDC GRY-RED)

036-5509-31B (ICT/KAL ONLY) / 036-5509-31C (ODA ONLY) / 036-5509-31D (SPAIN ONLY)

NON-US NON-C120 2-SLOT COIN DOOR
USES CABLE WIRING HARNESS
036-5509-32

NON-US NON-C120 3-SLOT COIN DOOR
USES CABLE WIRING HARNESS
036-5509-33

IF YOUR GAME HAS AN ELECTRONIC COIN MECH. INTERFACE PC BOARD (520-5193-00):

1-SLOT COIN DOOR USE WITH C120 CAPABILITIES REQUIRING PCB 520-5193-00
USES CABLE WIRING HARNESS
036-5509-31 (S.A.M. SYSTEM)

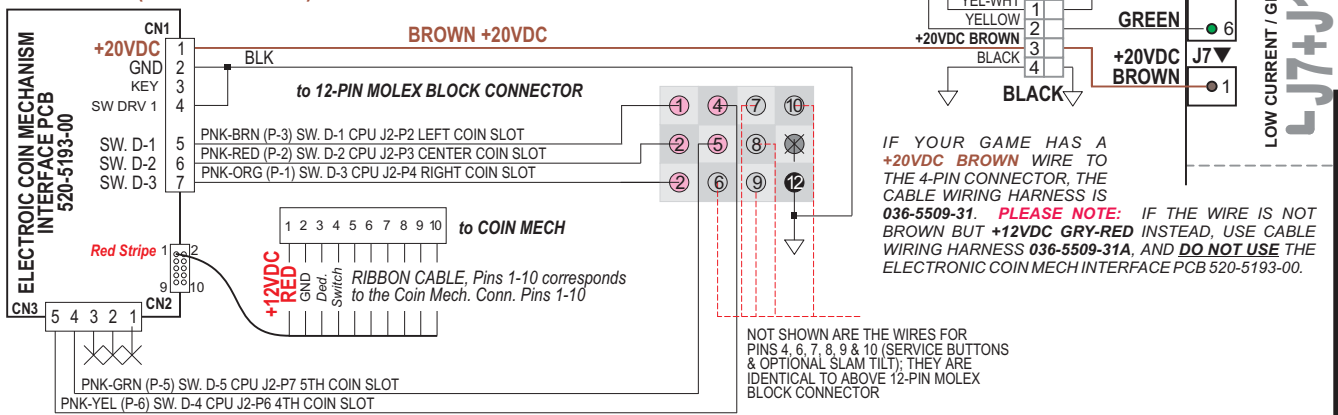

~ WIRING CONFIGURATION WILL VARY ACCORDING TO COUNTRY ~



Printed Circuit Boards (PCBs)

Trough Up-Kicker Dual OPTO PCBs (515-0173-00 & 515-0174-00) Theory of Op. & Schematic

As light from the **Transmitter LED1** falls on the **Receiver LED1**, it generates a Positive Bias Voltage (0.7v to 1.5v) which is applied to the **Gate (G)** of **Q1 (Fet 2N5460)** turning **Q1** off. When **Q1** is held off, no current flows through **Q2's (2N3906) Base (B)**. With no *base current*, **Q2** is off and acts as an **OPEN SWITCH**. When the light is interrupted (**BLOCKED**) **R1 (Rec. Bd.)** bleeds the gate voltage off of **Q1** allowing it to conduct, switching **Q2** on, which acts as a **CLOSED SWITCH**. The **LED2 (Trans/Rec) Circuit** operates identical as the **LED1 Circuit**.

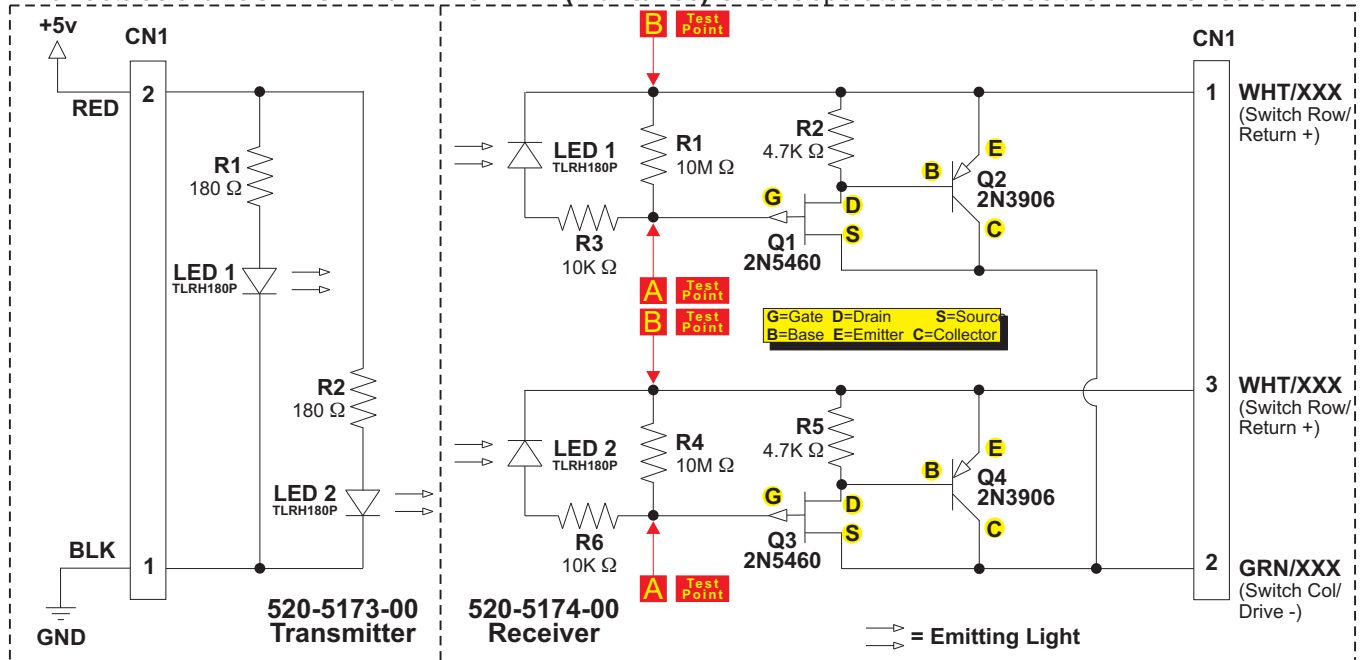

Trough Up-Kicker Dual OPTO PCBs (515-0173-00 & 515-0174-00) Component Layout & Parts

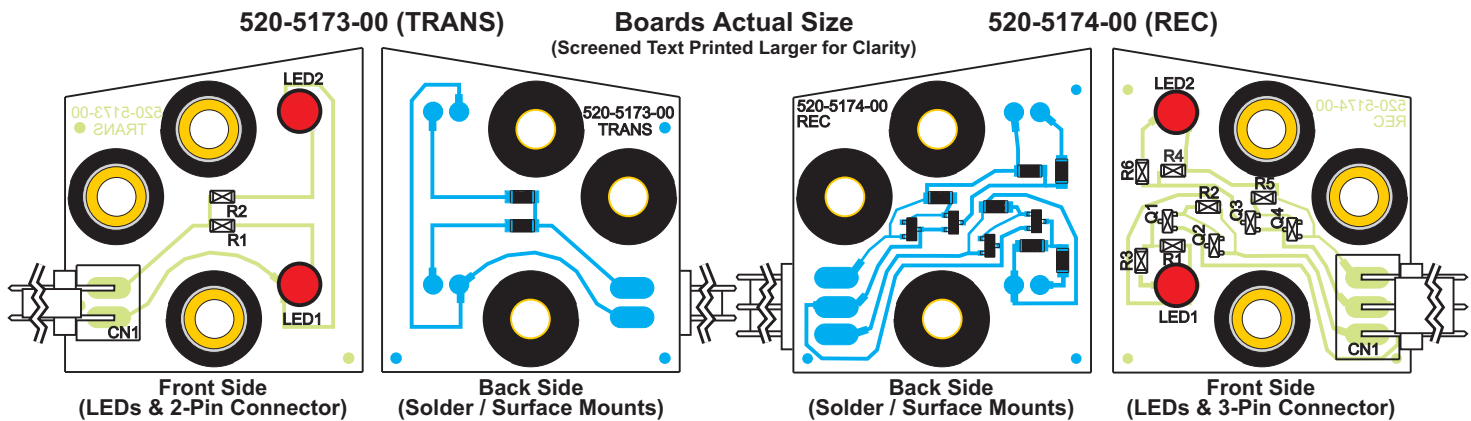

ITEM	QTY	PART NUMBER	REF-DESIGNATOR	DESCRIPTION
A+C & D	1	515-0173-00		Dual-OPTO Transmitter PCB Assembly (Item A PCB + Items C & D)
A	1	520-5173-00		Dual-OPTO Transmitter PCB
A-1	1	045-5111-02	CN1	(includes Items A-1 – A-3) 2X, .156" Rt. Angle (26-60-5020) Conn.
A-2	2	165-5052-00	LED1, LED2	LED TLRH180P (Ultra Bright Red)
A-3	2	121-5067-00	R1, R2	180 Ω Resistor SMT, 1/8W (CRCW)
B+C & D	1	515-0174-00		Dual-OPTO Receiver PCB Assembly (Item B PCB + Items C & D)
B	1	520-5174-00		Dual-OPTO Receiver PCB
B-1	1	045-5111-03	CN1	(includes Items B-1 – B-7) 3X, .156" Right Angle (26-60-5030) Conn.
B-2	2	165-5052-00	LED1, LED2	LED TLRH180P (Ultra Bright Red)
B-3	2	110-5006-00	Q1, Q3	2N5460, Transistor (P-FET SOT-23)
B-4	2	110-0086-00	Q2, Q4	2N3906, Transistor
B-5	2	121-5082-00	R1, R4	10M Ω Resistor SMT, 1/8W (CRCW)
B-6	2	121-5083-00	R2, R5	4.7K Ω Resistor SMT, 1/8W (CRCW)
B-7	2	121-5011-00	R3, R6	10K Ω Resistor SMT, 1/8W (CRCW)
C	3/per	530-5308-02		OPTO PCB Brass Tube Spacer
D	3/per	545-5518-00		OPTO PCB Rubber Grommet

Replacement Part:
LED TLRH180P
 (T1-3/4 GaAIAs)
 SPI Part N^o:
165-5052-00

Sec. 5: PCBs



OPTO Troubleshooting

1. Volt Meter Test (indicates normal operating condition):

A. **OPEN OPTO** (Light Falling on LED) = *SWITCH OPEN*. Place meter leads across points **A** and **B** on the **LED1 Circuit** (Refer to Schematic Drawing on previous page, 520-5174-00 Receiver Side). It should read approximately 0.8 - 1.2v DC. The **LED2 Circuit** operates the same.

B. **CLOSED OPTO** (Light Blocked) = *SWITCH CLOSED*. Place meter leads across points **A** and **B** on the **LED1 Circuit** (Refer to Schematic Drawing on previous page, 520-5174-00 Receiver Side). It should read approximately 0.0 - 0.1v DC. The **LED2 Circuit** operates the same.

2. Oscilloscope Test (indicates normal operating condition):

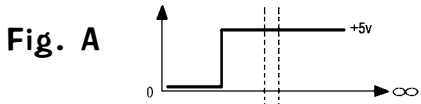

A. **OPEN OPTO** (Light Falling on LED) = *SWITCH OPEN*. Place Scope lead at **Pin-1** of OPTO Rec. Board with Scope Grounded (see Schematic). The Scope should display a **STEADY +5v** as shown in **Fig. A**, Wave Form Diagram.

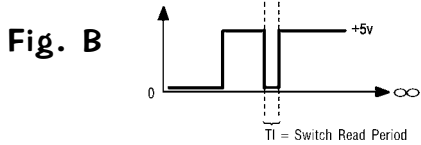

B. **CLOSED OPTO** (Light Blocked) = *SWITCH CLOSED*. Place Scope lead at **Pin-1** of OPTO Rec. Board with Scope Grounded (see Schematic). The Scope should display a **PULSE STREAM** indicating **Q2** has switched "On" as shown in **Fig. B**, Wave Form Diagram. This is your Switch Drive Pulse.

3. Bench Test (See Fig. C):

Please Note: To perform this test you must use a spare 560Ω Pull-Up Resistor, SPI N^o: 121-5047-00

Disconnect the **OPTO Transmitter / Receiver Board** from the circuit. Connect one side of a 560Ω Pull-Up Resistor to **Pin-1** of the OPTO Receiver Bd. and the other side of the resistor to a 5v DC source. Connect **Pin-2** to GND. Connect a +5v DC source to **Pin-1** of the Transmitter & GND to **Pin-2**. Align with the Receiver OPTO approx. 3" distance. Using your Volt-Meter or an Oscilloscope, monitor **Pin-1** while **BLOCKING** and **UNBLOCKING** the **BEAM** from the Trans. The output will be approx. +5v DC when the **BEAM IS NOT BLOCKED** and approx. 0v when the **BEAM IS BLOCKED**.

Fig. C

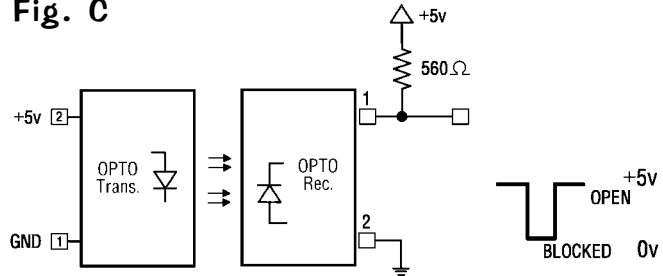

Trough Dual OPTO Boards Alignment / Test for LED1

When a working **OPTO** is installed and connected in a game, the transmitter should light (**LED1 lower & LED2 upper**) when the power is switched on. With the playfield in **Service Position #1** (playfield lifted up in the half-way position resting on the Prop Rod or edge slide support brackets) and the game on, the LED lights should show up as a **BRIGHT RED RINGS** through the back of the Receiver Board around the **Receivers LED1 & LED2** (see **Fig. 1**). Testing only **LED1**: With the game in **Switch Test Mode**, lifting the Trough Plunger with a fingertip should block the **BEAM** and cause the Switch Position to trigger (see **Fig. 2**). View **Fig. 2a & 2b** (on the next page) for a sectional view of the Light Path (note alignment) and what happens as a ball breaks the light beam.

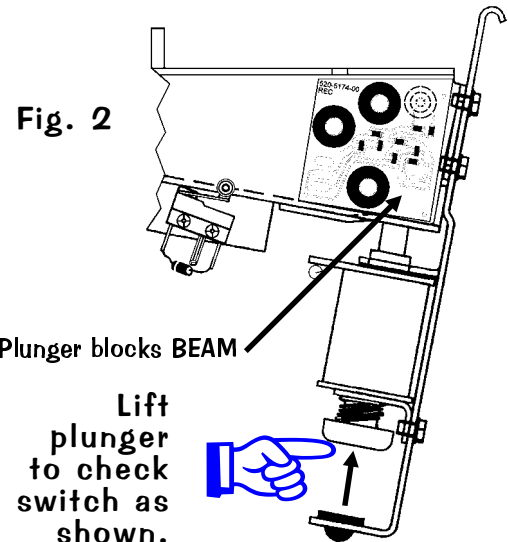
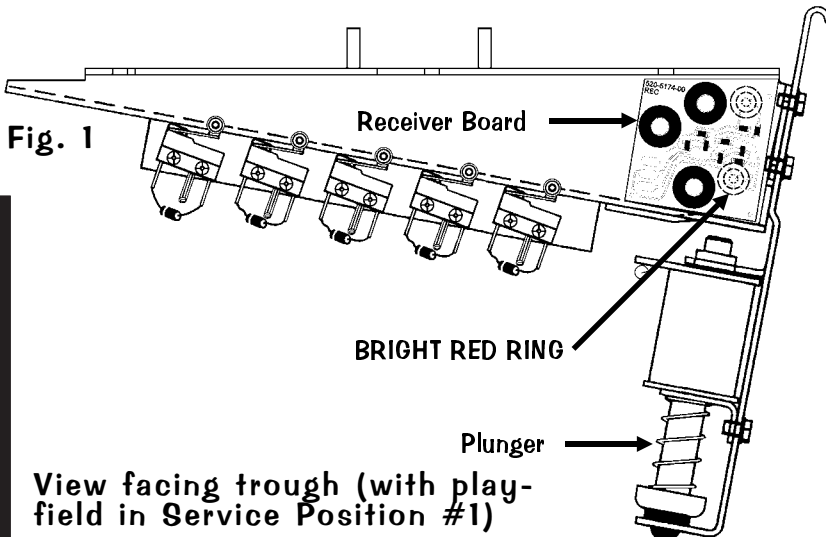

Sec. 5: PCBs



Sectional view from right (Fig. 2a & 2b)

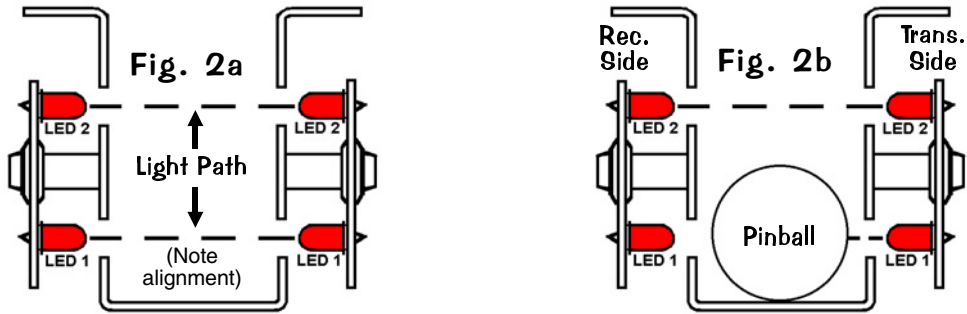

Trough Dual OPTO Boards Alignment / Test for LED2

When a working **OPTO** is installed and connected in a game, the transmitter should light (**LED1** lower & **LED2** upper) when the power is switched on. With the playfield in **Service Position #1** (playfield lifted up and resting on the Playfield Support Slide Brackets) and the game on, the LED lights should show up as a **BRIGHT RED RINGS** through the back of the Receiver Board around the **Receivers LED1 & LED2** (see Fig. 1, previous page). Testing only **LED2**: **TO PERFORM THIS TEST, A PINBALL MUST BE IN THE BALL TROUGH.** With the game in **Switch Test Mode**, lifting the Trough Plunger with a finger tip should block the **BEAM** on LED2 and cause the Switch Position to trigger (see Fig. 3). View Fig. 3a & 3b for a sectional view of the Light Path (note alignment) and what happens as a "double-stacked" ball scenario breaks the light beam.

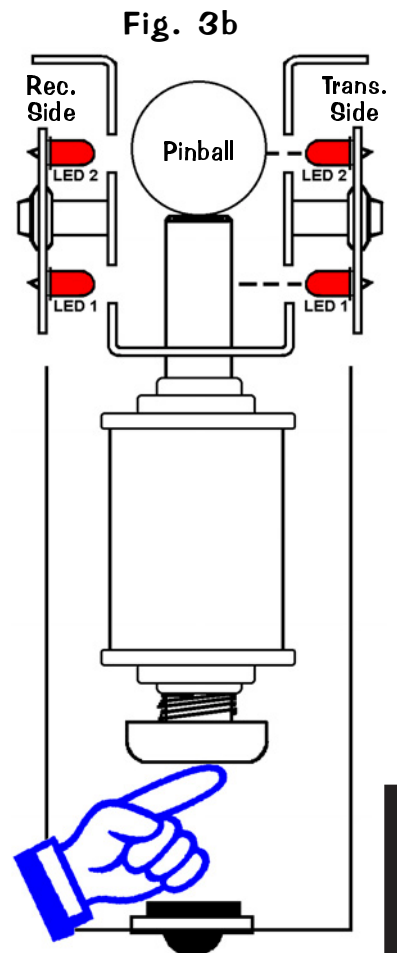
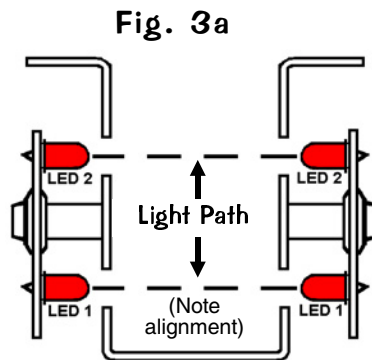
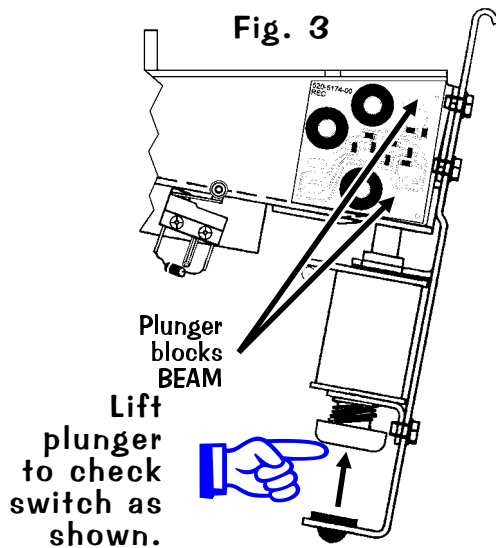

I M P O R T A N T

If replacement of **LED** is required, insure that is **mounted correctly before and after soldering** (See Fig. 4a / 4b).

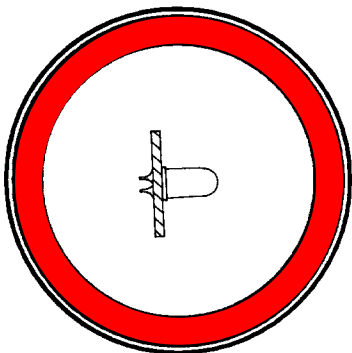

Fig. 4a
Correct Position

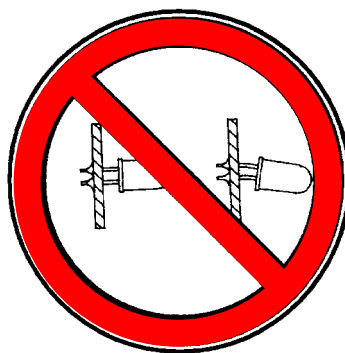
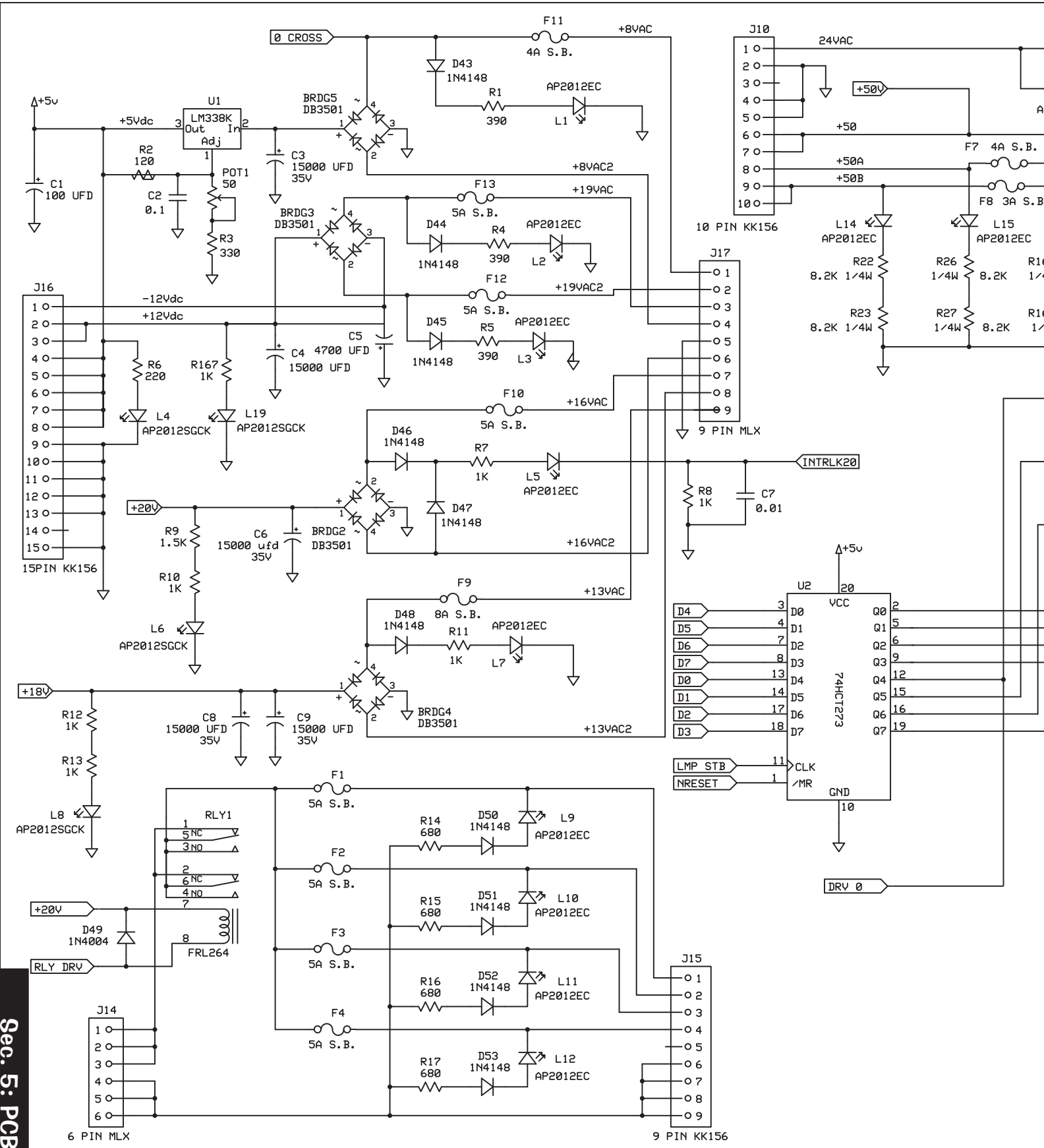

Fig. 4b
Incorrect Position

I/O POWER DRIVER PCB S.A.M. System (520-5249-00) Schematic (Sheet 1 of 4)



Sec. 5: PCBs



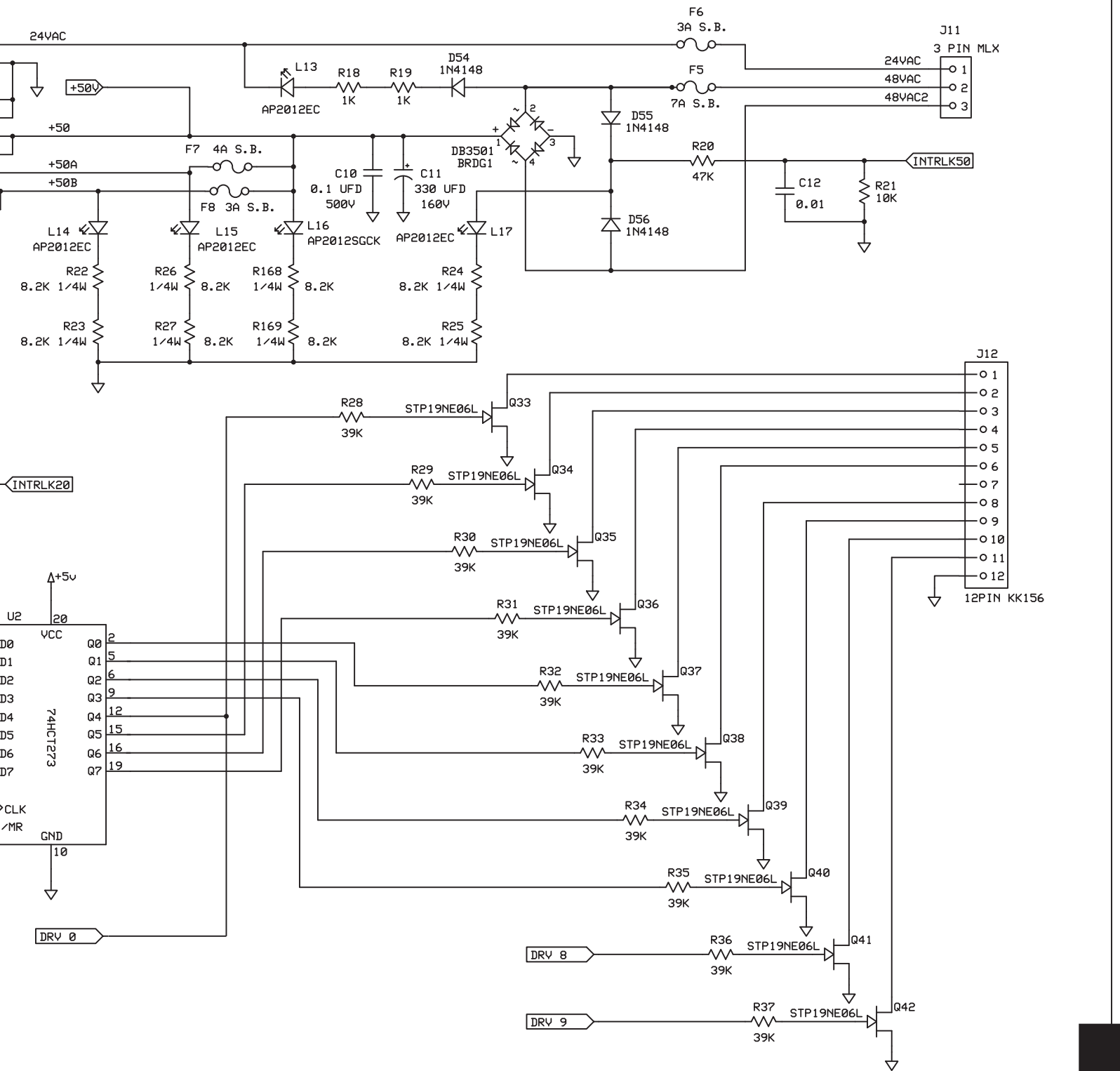

STERN PINBALL, INC.		
I/O POWER DRIVER BOARD		
520-5249-00	Rev A 5/20/2005	Page 1 of 4

Sec. 5: PCBs



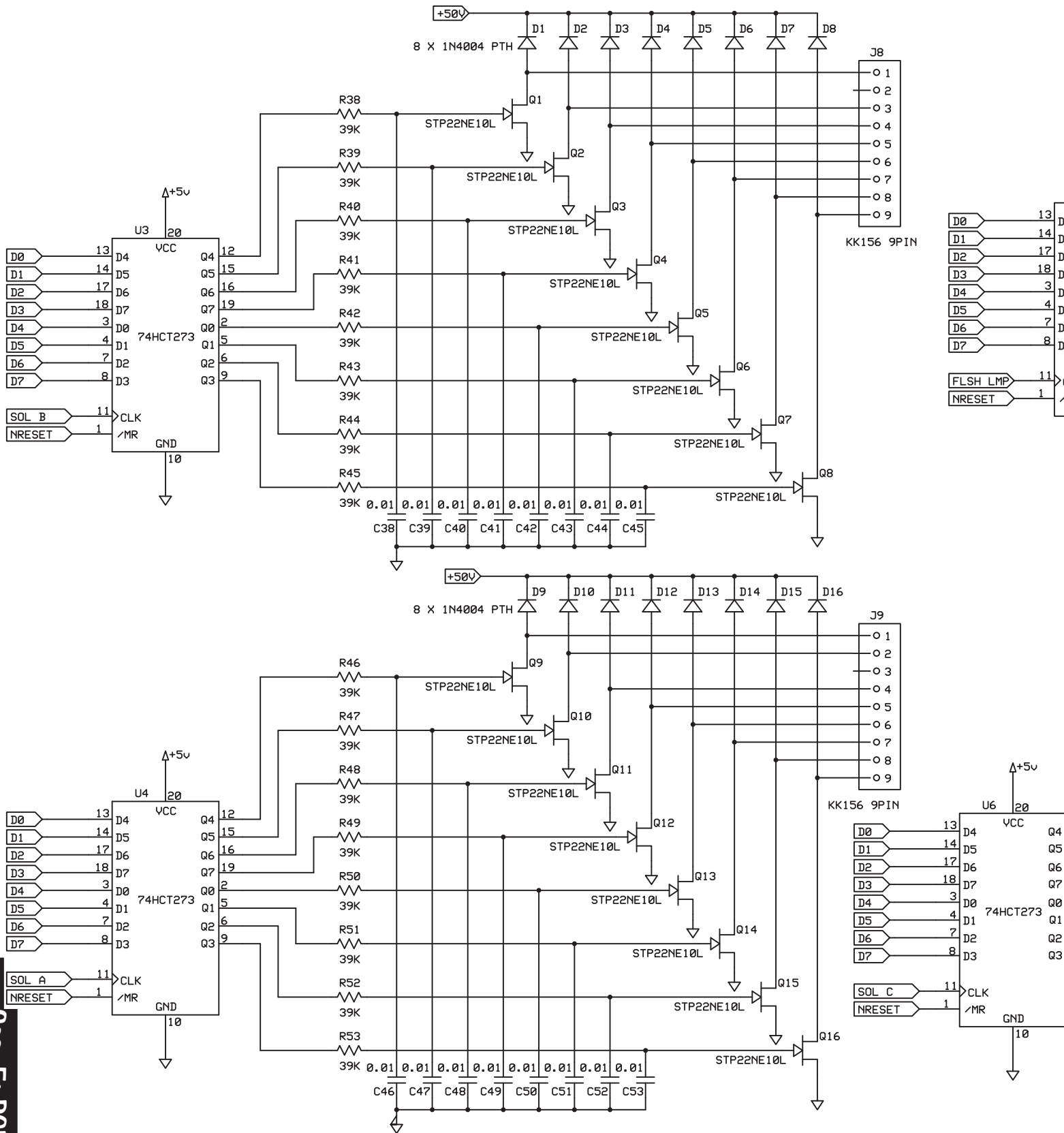

Sec. 5: PCBs



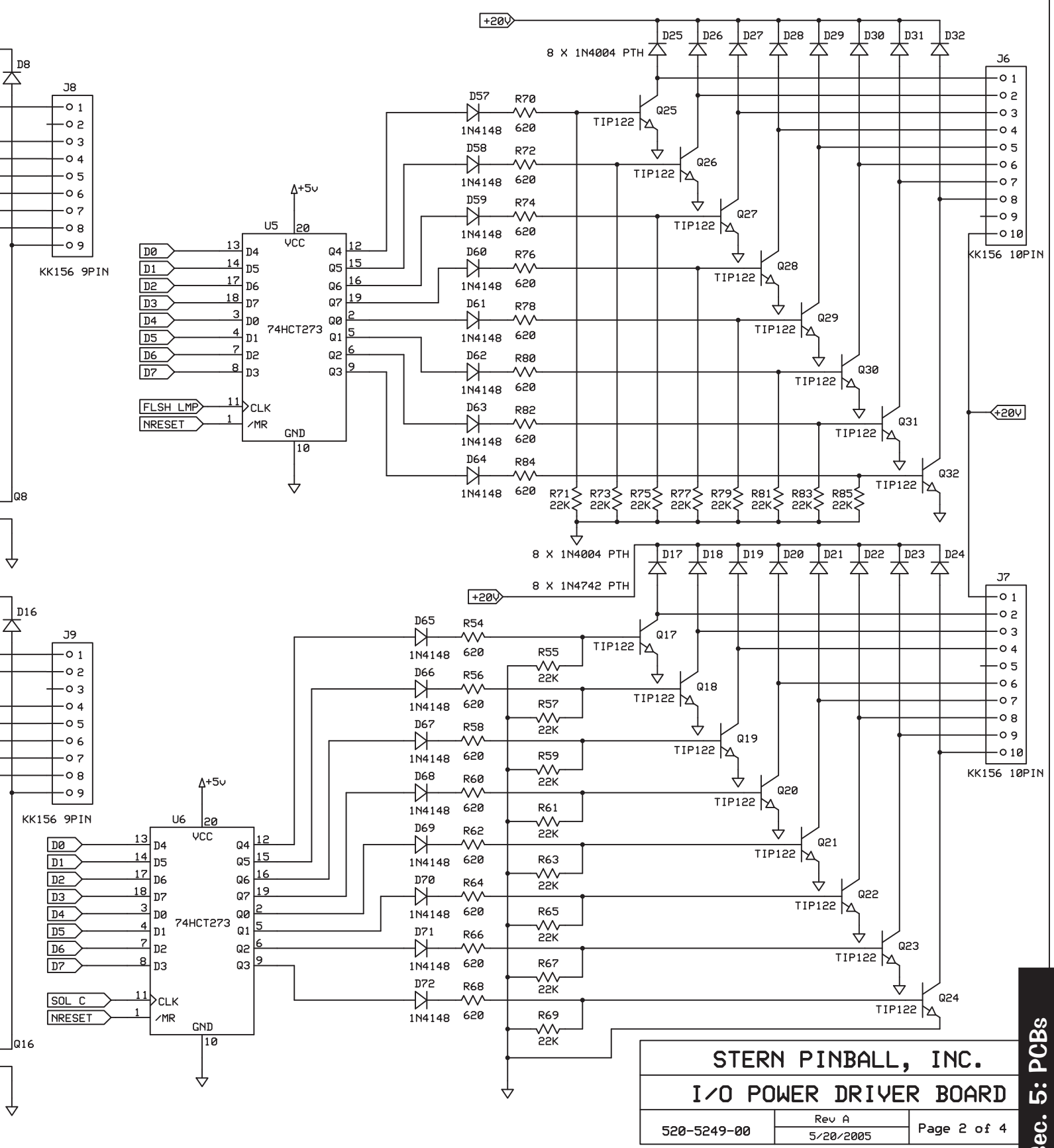

STERN PINBALL, INC.

I/O POWER DRIVER BOARD

520-5249-00	Rev A 5/20/2005	Page 2 of 4
-------------	--------------------	-------------

Sec. 5: PCBs



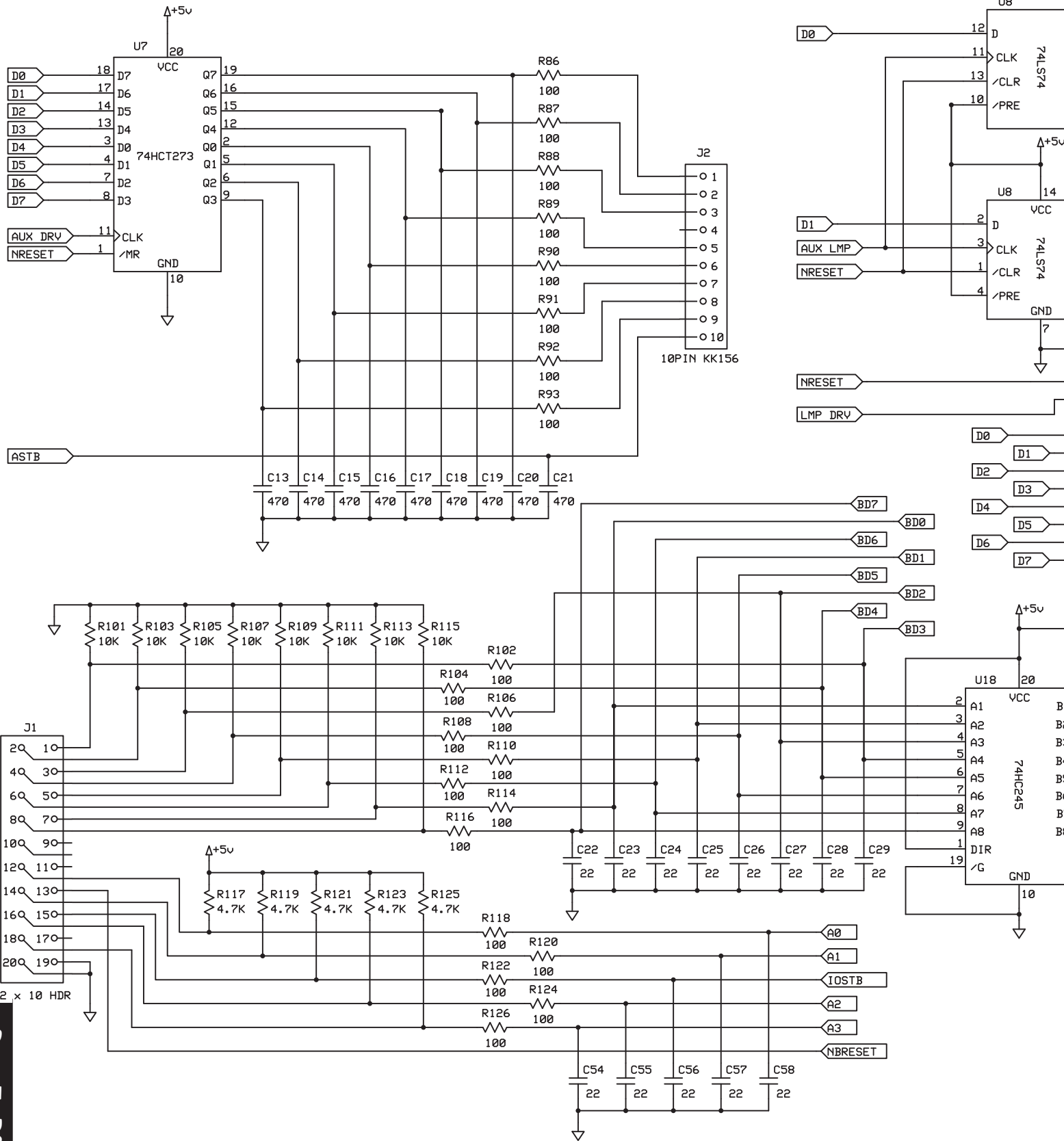

Sec. 5: PCBs



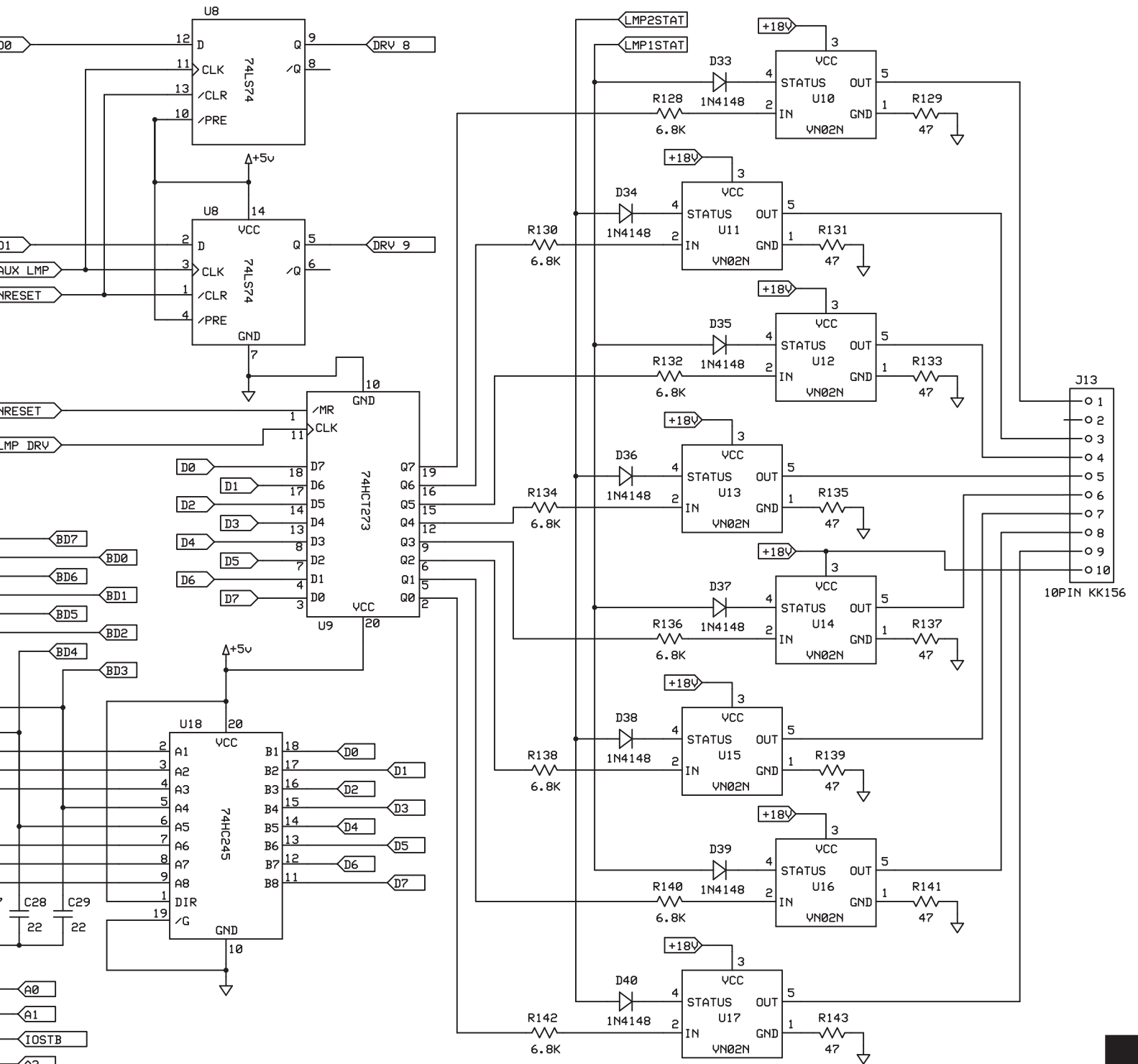

STERN PINBALL, INC.		
I/O POWER DRIVER BOARD		
520-5249-00	Rev A 5/20/2005	Page 3 of 4

Sec. 5: PCBs



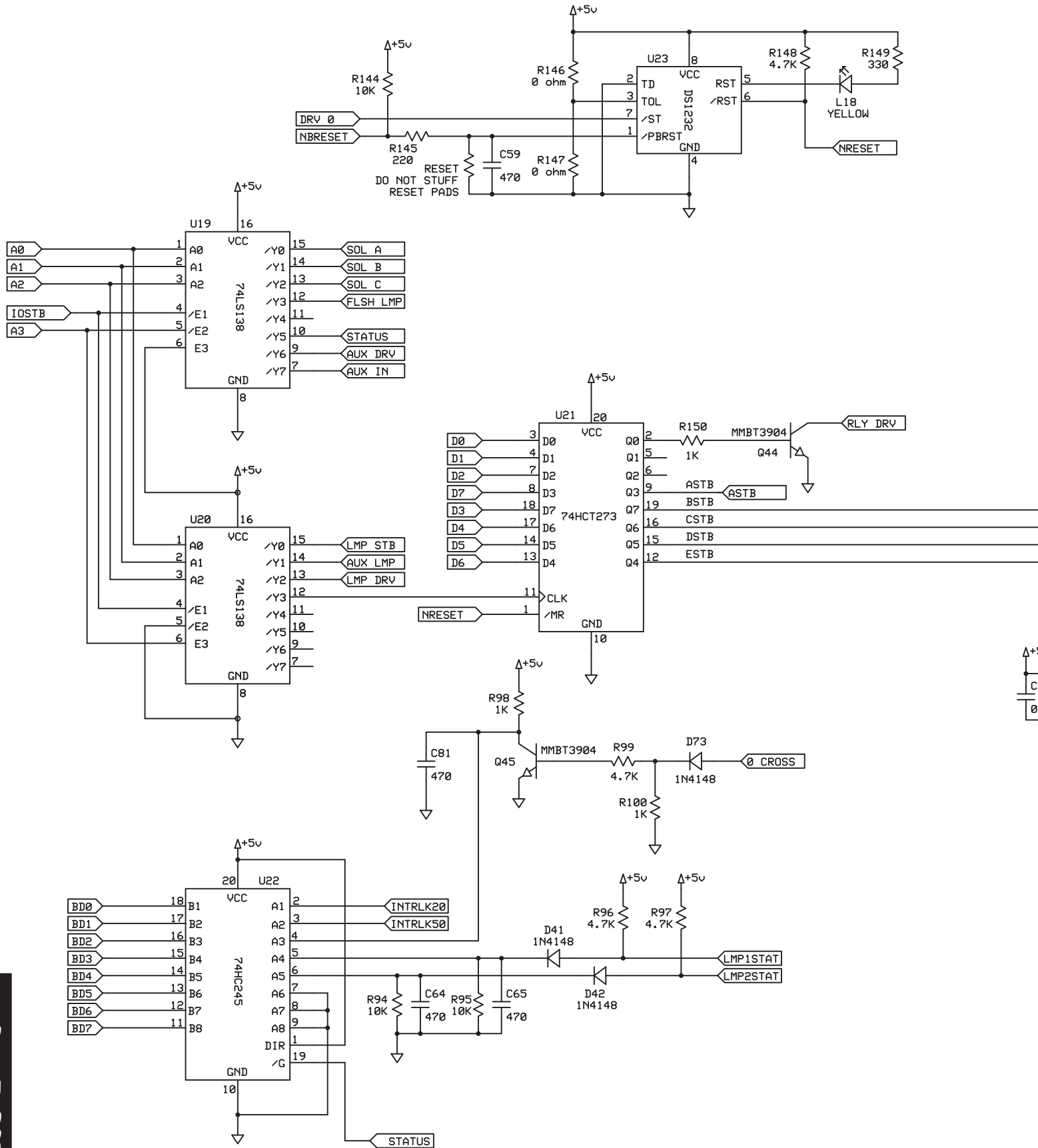

Sec. 5: PCBs



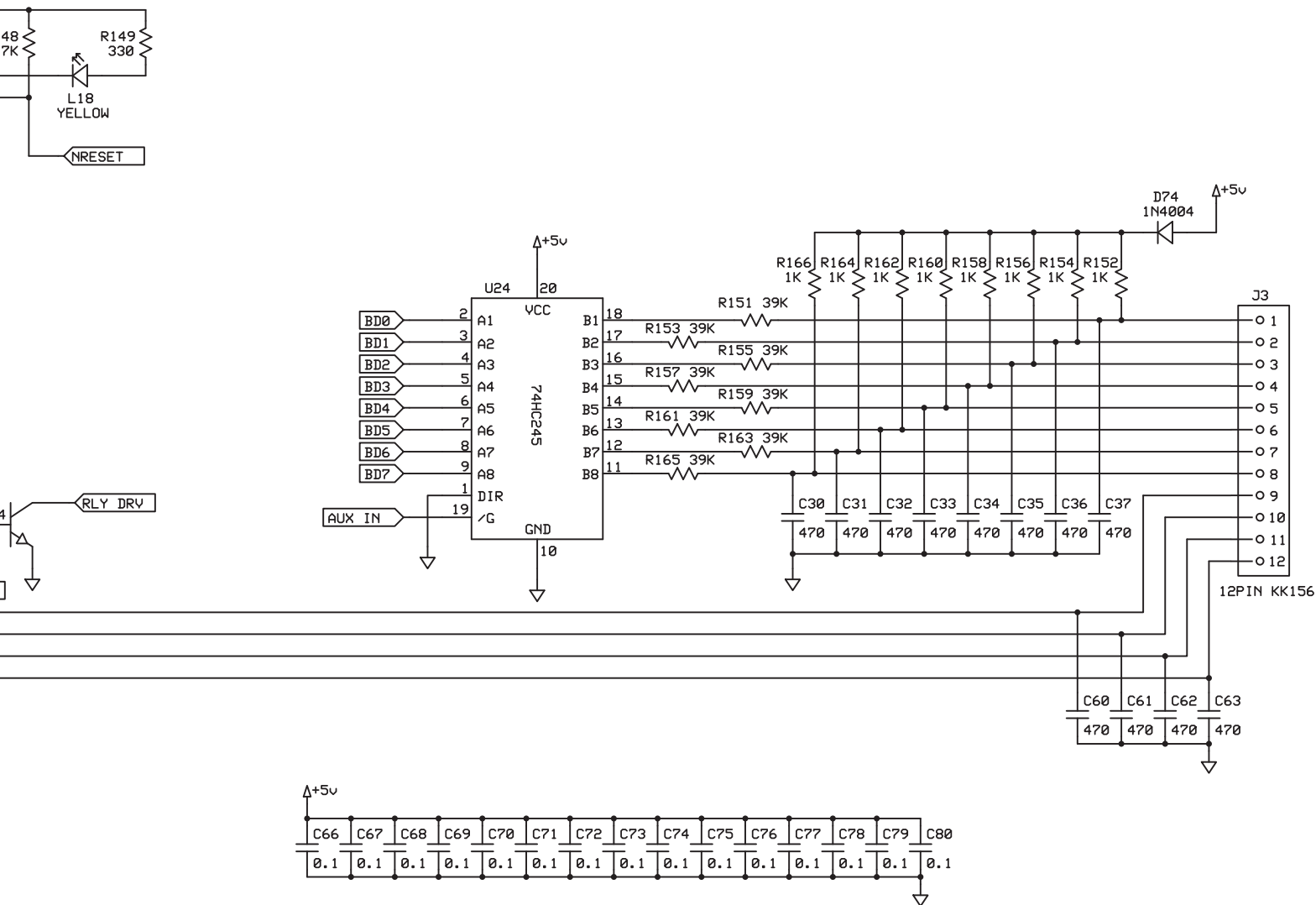

SS

STERN PINBALL, INC.		
I/O POWER DRIVER BOARD		
520-5249-00	Rev A 5/20/2005	Page 4 of 4

Sec. 5: PCBs



I/O POWER DRIVER PCB S.A.M. System (520-5249-00) Component Layout

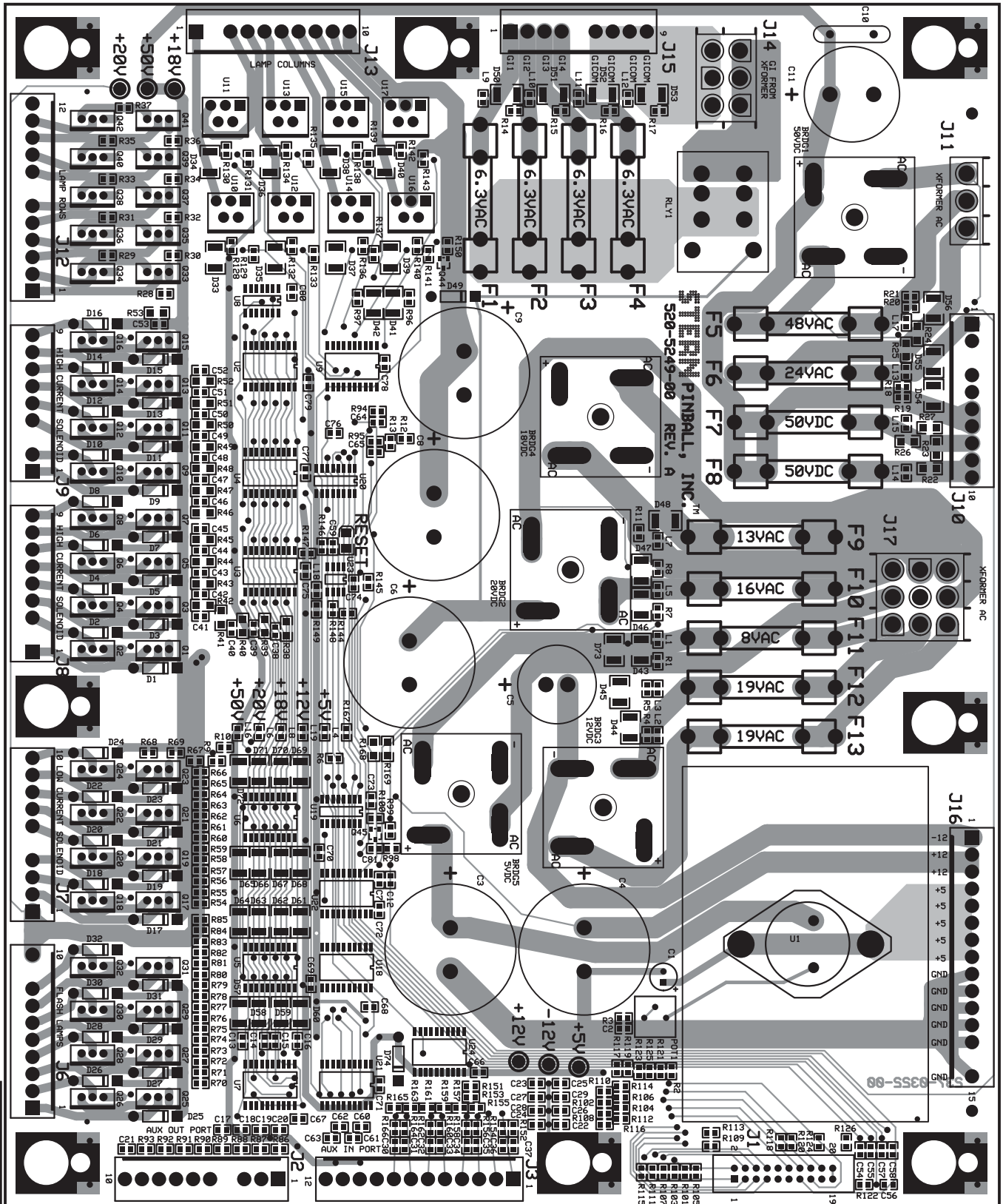

Sec. 5: PCBs



I/O POWER DRIVER PCB S.A.M. System (520-5249-00) Parts

ITEM	QTY.	SPI PART NUMBER	(MFG. P.N.)	REF-DESIGNATOR	DESCRIPTION (SM = Surface Mount)
—	1	520-5249-00		I/O Power Driver PCB (S.A.M. System), Rev. A	<i>(includes Items 1-67)</i>
1	1	121-6001-00	(101-0001807)	R9	Resistor SM 0805 Film 1.5KΩ 1/10W 5%
2	22	121-6002-00	(101-0001820)	R86, R87, R88, R89, R90, R91, R92, R93, R102, R104, R106, R108, R110, R112, R114, R116, R118, R120, R122, R124, R126, R146	Resistor SM 0805 Film 100Ω 1/10W 5%
3	12	121-6020-00	(101-0001827)	R21, R94, R95, R101, R103, R105, R107, R109, R111, R113, R115, R144	Resistor SM 0805 Film 10KΩ 1/10W 5%
4	1	121-6003-00	(101-0001845)	R2	Resistor SM 0805 Film 120Ω 1/10W 5%
5	20	121-6022-00	(101-0001905)	R7, R8, R10, R11, R12, R13, R18, R19, R98, R100, R150, R152, R154, R156, R158, R160, R162, R164, R166, R167	Resistor SM 0805 Film 1KΩ 1/10W 5%
6	2	121-6004-00	(101-0001943)	R6, R145	Resistor SM 0805 Film 220Ω 1/10W 5%
7	16	121-6005-00	(101-0001849)	R55, R57, R59, R61, R63, R65, R67, R69, R71, R73, R75, R77, R79, R81, R83, R85	Resistor SM 0805 Film 22KΩ 1/10W 5%
8	2	121-6006-00	(101-0002012)	R3, R149	Resistor SM 0805 Film 330Ω 1/10W 5%
9	3	121-6007-00	(101-0002031)	R1, R4, R5	Resistor SM 0805 Film 390Ω 1/10W 5%
10	8	121-6013-00	(101-0002035)	R151, R153, R155, R157, R159, R161, R163, R165	Resistor SM 0805 Film 39KΩ 1/10W 5%
11	9	121-6008-00	(101-0002046)	R96, R97, R99, R117, R119, R121, R123, R125, R148	Resistor SM 0805 Film 4.7KΩ 1/10W 5%
12	8	121-6014-00	(101-0002065)	R129, R131, R133, R135, R137, R139, R141, R143	Resistor SM 0805 Film 47Ω 1/10W 5%
13	1	121-6015-00	(101-0002071)	R20	Resistor SM 0805 Film 47KΩ 1/10W 5%
14	8	121-6009-00	(101-0002108)	R128, R130, R132, R134, R136, R138, R140, R142	Resistor SM 0805 Film 6.8KΩ 1/10W 5%
15	16	121-6010-00	(101-0002116)	R54, R56, R58, R60, R62, R64, R66, R68, R70, R72, R74, R76, R78, R80, R82, R84	Resistor SM 0805 Film 620Ω 1/10W 5%
16	4	121-6016-00	(101-0002126)	R14, R15, R16, R17	Resistor SM 0805 Film 680Ω 1/10W 5%
17	10	121-6011-00	(101-0002296)	R28, R29, R30, R31, R32, R33, R34, R35, R36, R37	Resistor SM 1206 Film 22KΩ 1/10W 5%
18	8	121-6012-00	(101-0002473)	R22, R23, R24, R25, R26, R27, R168, R169	Resistor SM 1206 Film 8.2KΩ 1/10W 5%
19	16	121-6013-01	(101-0002378)	R38, R39, R40, R41, R42, R43, R44, R45, R46, R47, R48, R49, R50, R51, R52, R53	Resistor SM 1206 Film 39KΩ 1/10W 5%
20	16	125-6001-00	(121-0000056)	C2, C66, C67, C68, C69, C70, C71, C72, C73, C74, C75, C76, C77, C78, C79, C80	Capacitor SM 0805 Cer. .1UF 50V 10% X7R
21	25	125-6002-00	(121-0000096)	C13, C14, C15, C16, C17, C18, C19, C20, C21, C30, C31, C32, C33, C34, C35, C36, C37, C59, C60, C61, C62, C63, C64, C65, C81	Capacitor SM 0805 Cer. 470PF 50V 5% NPO
22	18	125-6003-00	(121-0004236)	C7, C12, C38, C39, C40, C41, C42, C43, C44, C45, C46, C47, C48, C49, C50, C51, C52, C53	Capacitor SM 0805 Cer. .01UF 50V 10% X7R
23	13	125-6004-00	(121-0005318)	C22, C23, C24, C25, C26, C27, C28, C29, C54, C55, C56, C57, C58	Capacitor SM 0805 Cer. 22PF 100V 5% NPO
24	1	125-5032-00	(131-0003773)	C1	Capacitor Tht. Radial Alum. 100UF 25V 20%
25	1	125-5034-00	(131-0003864)	C5	Capacitor Tht. Radial Alum. 4700UF 35V 20%
26	1	125-5029-01	(133-0003741)	C10	Capacitor Tht. Disc Cer. .1UF 500V 20%
27	1	125-6022-00	(134-0003846)	C11	Capacitor Tht. Radial Alum. 330UF 160V 20%
28	5	125-5036-01	(134-0004000)	C3, C4, C6, C8, C9	Cap. Tht. Rad. Al. 15000UF 35V 20% Snap-In
29	34	112-6001-01	(183-0004374)	D1, D2, D3, D4, D5, D6, D7, D8, D9, D10, D11, D12, D13, D14, D15, D16, D17, D18, D19, D20, D21, D22, D23, D24, D25, D26, D27, D28, D29, D30, D31, D32, D49, D74	Diode Tht. DO-41 1N4004 400V 1A
30	5	112-5000-00	(187-0004700)	BRDG1, BRDG2, BRDG3, BRDG4, BRDG5	Bridge Tht. Fullwave 100V 35A MB-35
31	10	110-0088-01	(203-0003591)	Q33, Q34, Q35, Q36, Q37, Q38, Q39, Q40, Q41, Q42	Fet Tht. TO-220 STP20NE06L NFet 60V 20A
32	16	110-0106-00	(203-0003592)	Q1, Q2, Q3, Q4, Q5, Q6, Q7, Q8, Q9, Q10, Q11, Q12, Q13, Q14, Q15, Q16	Fet Tht. TO-220 20N10L NFet 100V 20A
33	8	110-0089-00	(203-0003597)	U10, U11, U12, U13, U14, U15, U16, U17	Fet Tht. PENTAWAT VN02N NFet HighSide 26V 6A
34	2	110-0069-01	(211-0003589)	Q44, Q45	Trans. SM SOT-23 MMST3904 NPN 40V 0.2A
35	16	110-0067-00	(213-0003565)	Q17, Q18, Q19, Q20, Q21, Q22, Q23, Q24, Q25, Q26, Q27, Q28, Q29, Q30, Q31, Q32	Transistor Tht. TO-220 TIP122 NPN 100V 5A
36	3	100-6003-00	(221-0000972)	U18, U22, U24	I.C. SM SOIC 74HC245 Oct. Bus. Xcvr.
37	1	100-6000-00	(221-0011253)	U23	I.C. SM SOIC DS1832S, SO-8
38	8	100-5056-00	(221-0001287)	U2, U3, U4, U5, U6, U7, U9, U21	I.C. SM SOIC 74HCT273 Oct. D F-F
39	2	100-6001-00	(221-0003728)	U19, U20	I.C. SM SO 74LS138D Hex Inverter; 3-8 DC/DMX
40	1	100-6002-00	(221-0011135)	U8	I.C. SM SOIC 74LS74AD SOIC-14
41	1	100-0356-00	(225-0003582)	U1	I.C. Tht. TO-3 LM338 5A Adjust. Voltage Reg.
42	5	045-	(315-0003427)	J2, J6, J7, J10, J13	Con. Tht. Hdr. 10 Pin, 1 Row .156"
43	1	045-	(315-0006910)	J1	Con. Tht. Hdr. 20 Pin, 2 Row .1"
44	2	045-	(315-0003430)	J3, J12	Con. Tht. Hdr. 12 Pin, 1 Row .156"
45	1	045-	(315-0003432)	J16	Con. Tht. Hdr. 15 Pin, 1 Row .156"
46	1	045-	(315-0003503)	J11	Con. Tht. Pwr. 3 Pin, 1 Row .25"
47	1	045-	(315-0003504)	J14	Con. Tht. Pwr. 6 Pin, 2 Row .25"
48	1	045-	(315-0003505)	J17	Con. Tht. Pwr. 9 Pin, 3 Row .25"
49	3	045-	(315-0003821)	J8, J9, J15	Con. Tht. Hdr. 9 Pin, 1 Row .156"
50	2	200-5000-08	(407-0003117)	F6, F8	Fuse 3 Amp 250V Slo-Blo (Glass, Tht. 3AG)
51	2	200-5000-06	(407-0003118)	F7, F11	Fuse 4 Amp 250V Slo-Blo (Glass, Tht. 3AG)
52	7	200-5000-01	(407-0003119)	F1, F2, F3, F4, F10, F12, F13	Fuse 5 Amp 250V Slo-Blo (Glass, Tht. 3AG)
53	1	200-5000-03	(407-0003121)	F5	Fuse 7 Amp 250V Slo-Blo (Glass, Tht. 3AG)
54	1	200-5000-05	(407-0003122)	F9	Fuse 8 Amp 250V Slo-Blo (Glass, Tht. 3AG)
55	1	121-5039-00	(415-0004788)	POT1	Potentiometer THT 50Ω Single Top Adjust. Trimr.
56	1	165-6000-00	(425-0006913)	L18	LED SM Yellow 0805 LED
57	5	165-6001-00	(425-0007753)	L4, L6, L8, L16, L19	LED SM Green Ultrabright Top
58	13	165-6002-00	(425-0007755)	L1, L2, L3, L5, L7, L9, L10, L11, L12, L15, L17	LED SM Red Ultrabright Top 0805 LED
59	1	190-5002-00	(448-0004778)	RLY1	Relay Tht. GW DPDT10A DC24 2400VA PC MNT
60	1	127-5001-00	(461-0003520)	for BRDG 4, BRDG 5	Heatsink, Sq. Finned Ba TO-220 Avid 531102
61	1	127-5001-02	(461-0003534)	for U1	Heatsink All Large Finned Alum. TO-3
62	1	127-5001-04	(579103B00000G)	for U1 on TO-3 LM338 5A Adj. Volt. Reg.	Heatsink, Circular Finned (Mfg. Aavid)
63	4	240-5008-00	(503-0004469)	2 pcs. for U1, 1 pc. each for BRDG 4 & 5	#6-32 Keps Nut
64	26	205-0004-00	(503-0004667)	2 pcs. each for F1 - F13	Fuseclip with End Stops (+ Ears)
65	4	237-5504-00	(504-0004610)	2 pcs. for U1, 1 pc. each for BRDG 4 & 5	#6-32 X 3/4" PPH MS (Zinc) Screw
66	2	254-5007-02	(507-0004544)	for BRDG 4 & 5 (Mfg. .169" I.D. X 9/32" O.D. X 1/4")	1/4" Sif. Rtn. Spacer White
67	5	254-5007-05	(507-0004547)	for BRDG1, 2 & 3 and for Mounting Holes	5/16" Sif. Rtn. Spacer White

Sec. 5: PCBs



CPU / SOUND PCB S.A.M. System (520-5246-00) Schematic (Sheet 1 of 5)

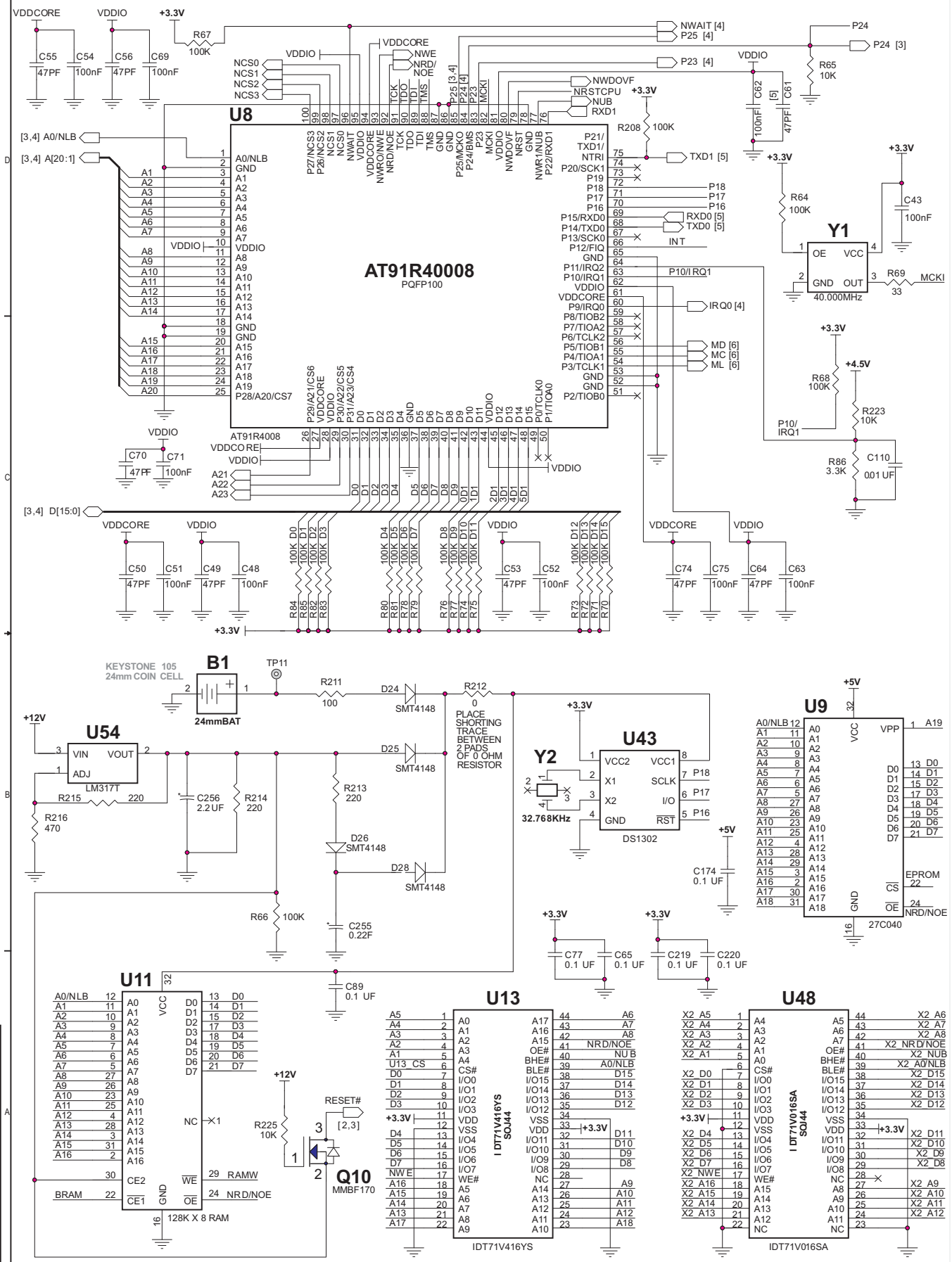

Sec. 5: PCBs



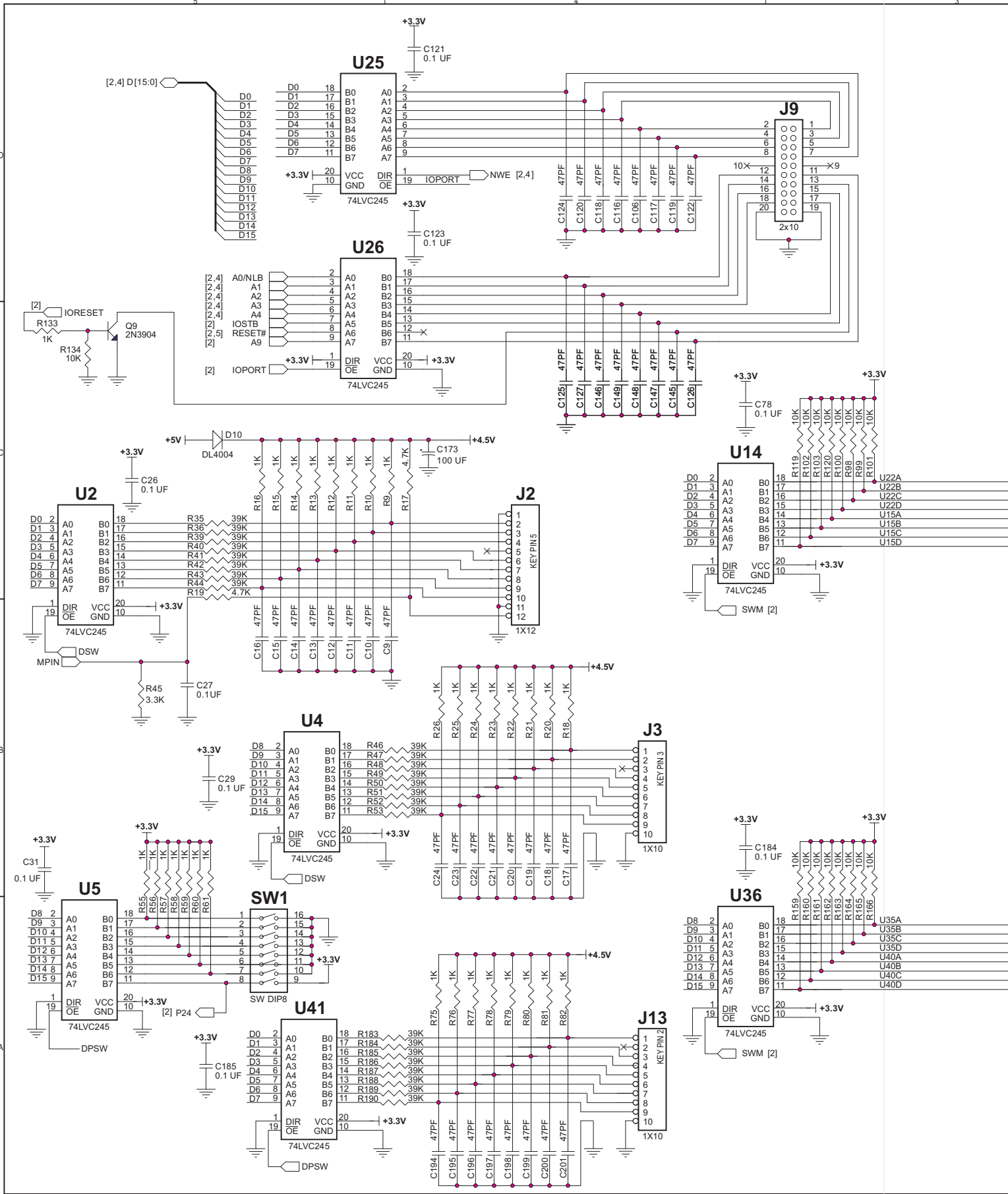

Sec. 5: PCBs



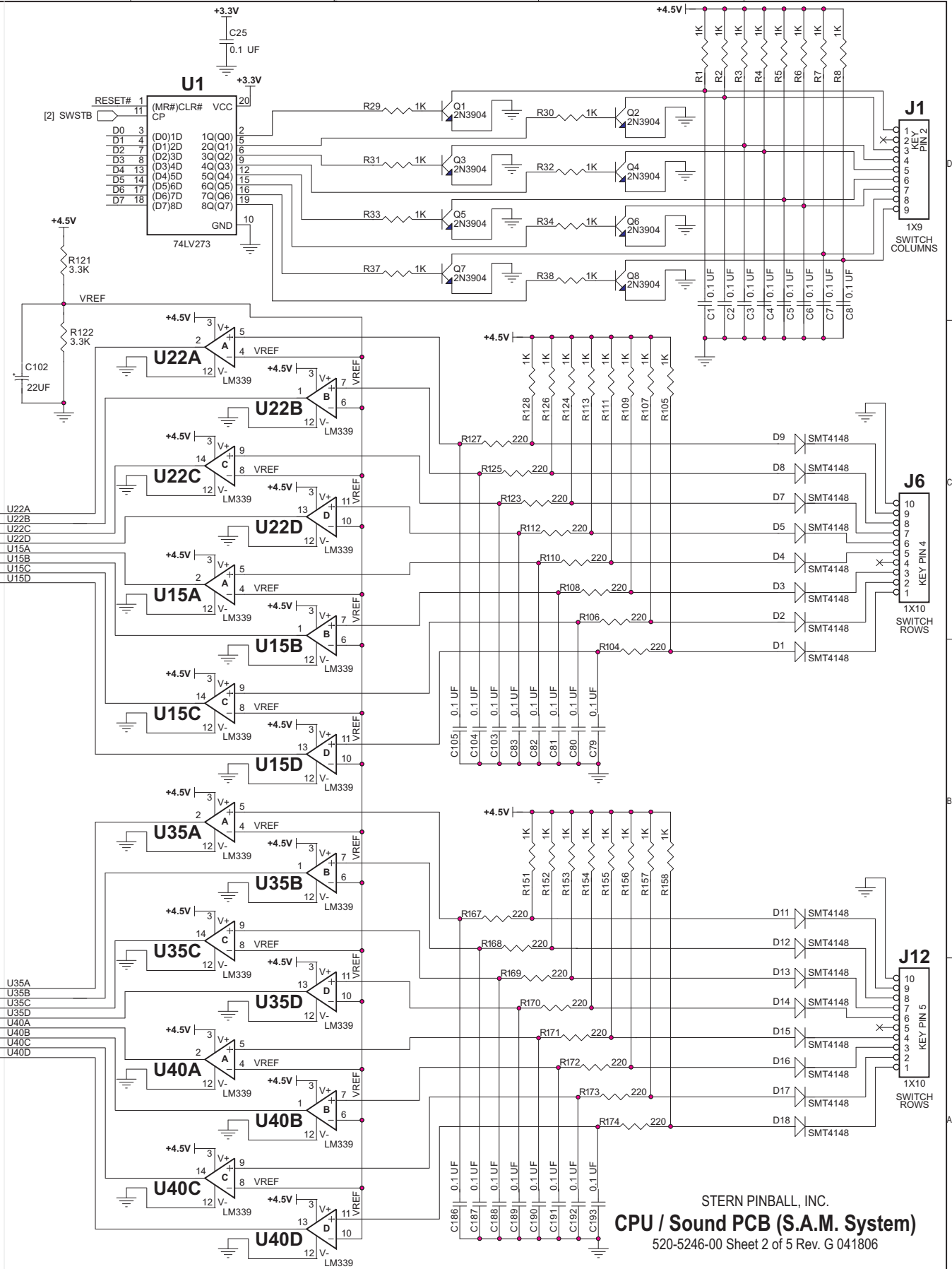

STERN PINBALL, INC.
CPU / Sound PCB (S.A.M. System)
 520-5246-00 Sheet 2 of 5 Rev. G 041806

Sec. 5: PCBs



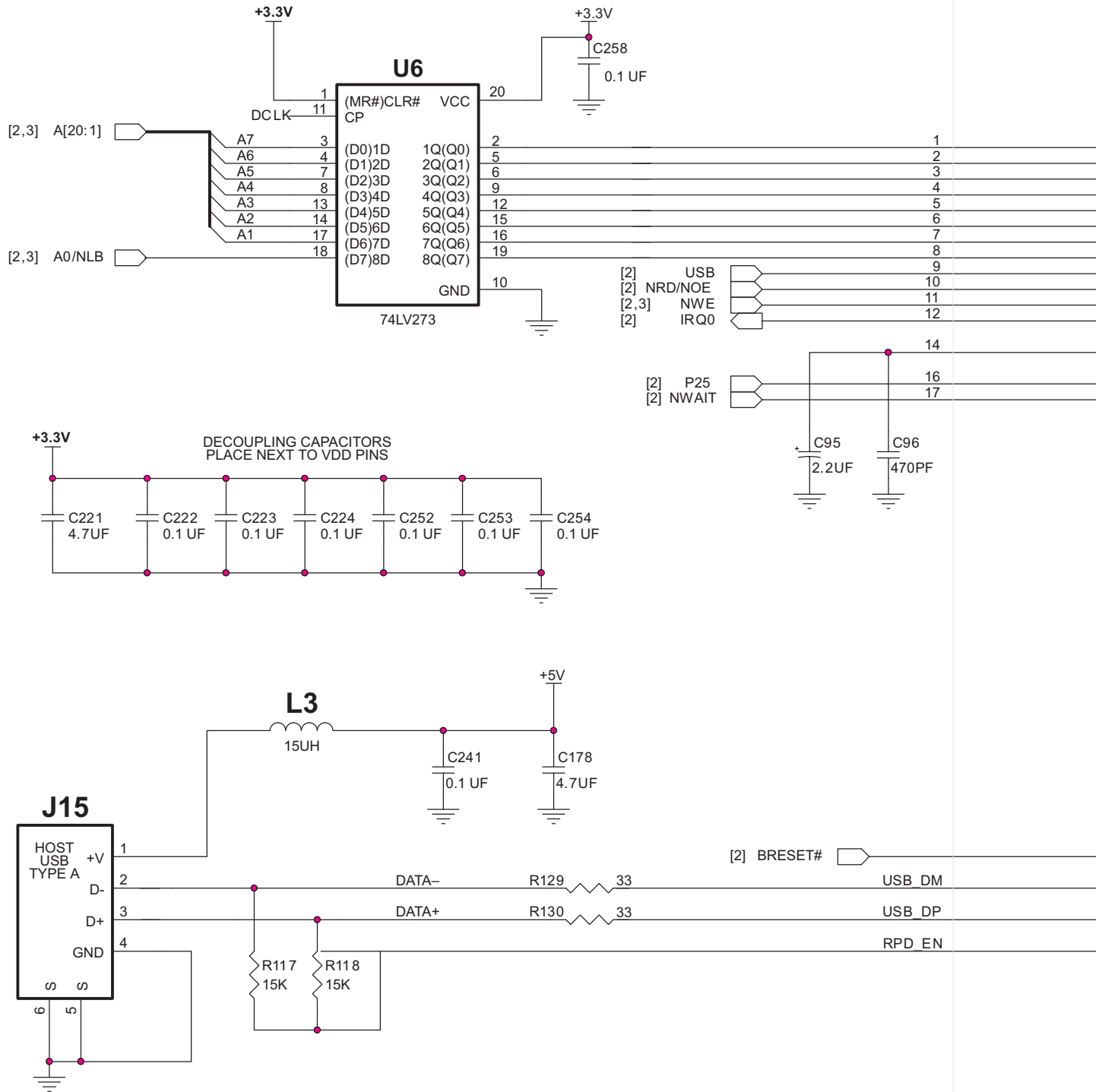

Sec. 5: PCBs



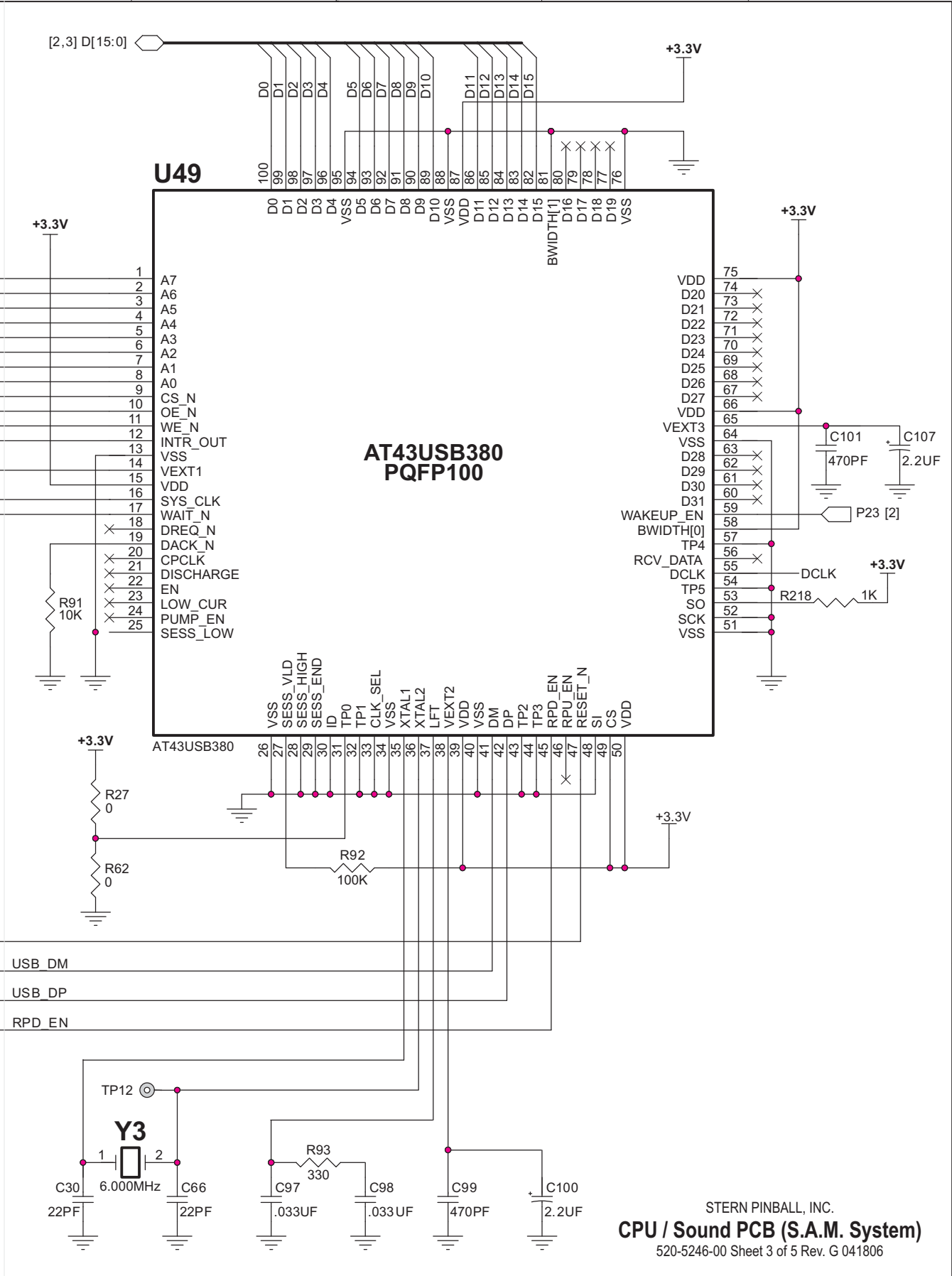

STERN PINBALL, INC.
CPU / Sound PCB (S.A.M. System)
 520-5246-00 Sheet 3 of 5 Rev. G 041806

Sec. 5: PCBs



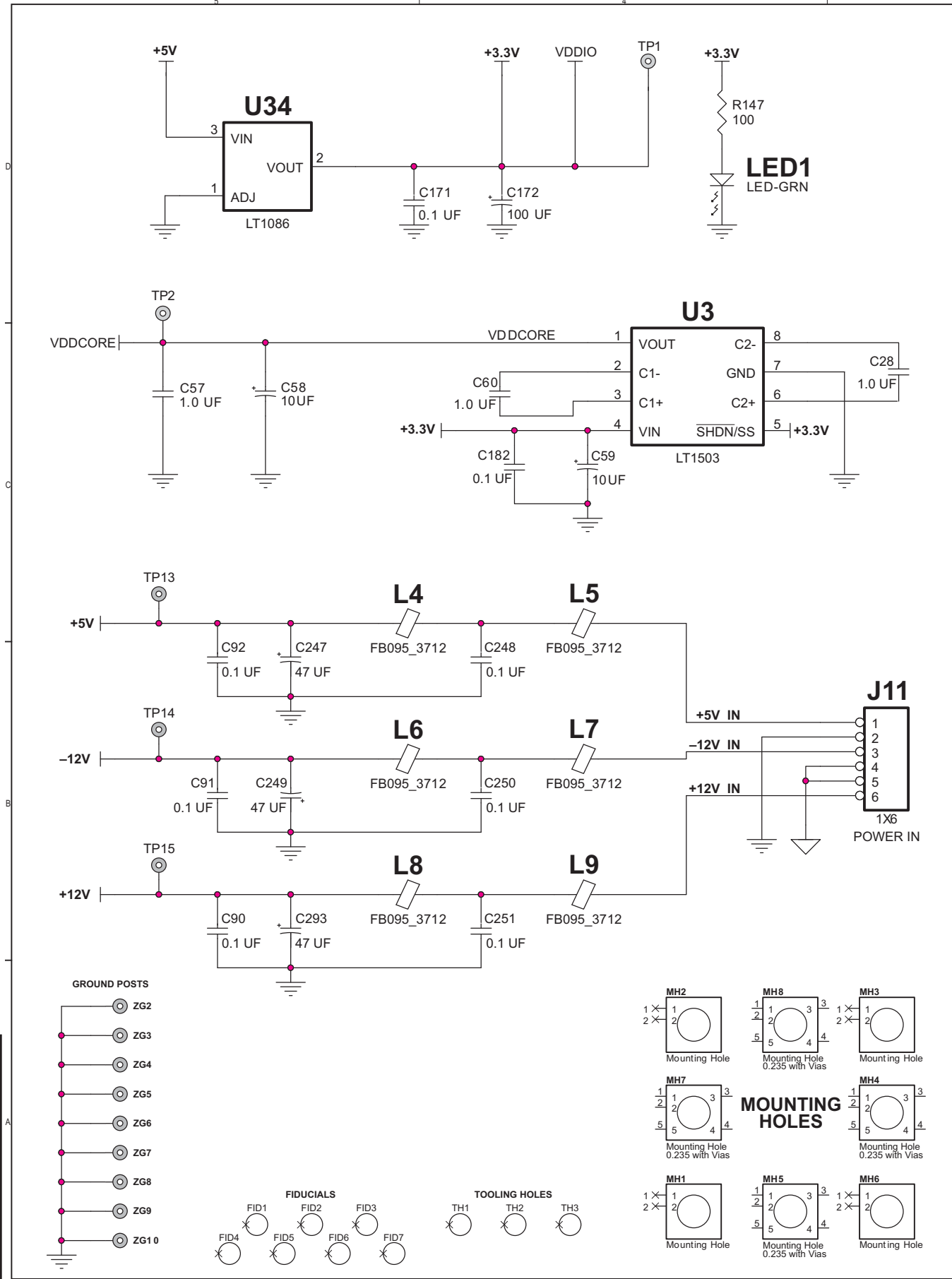

Sec. 5: PCBs



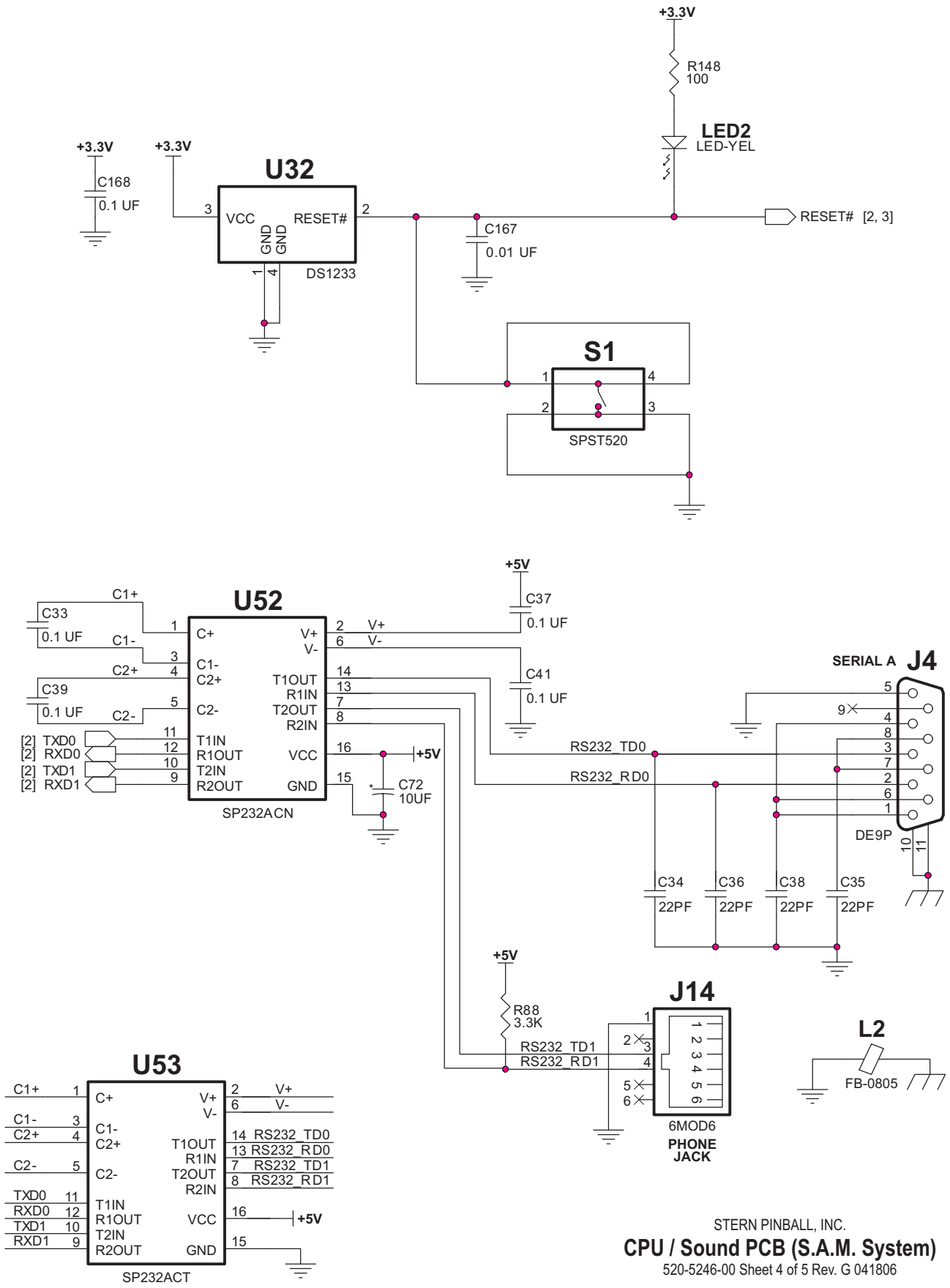

STERN PINBALL, INC.
CPU / Sound PCB (S.A.M. System)
 520-5246-00 Sheet 4 of 5 Rev. G 041806

Sec. 5: PCBs



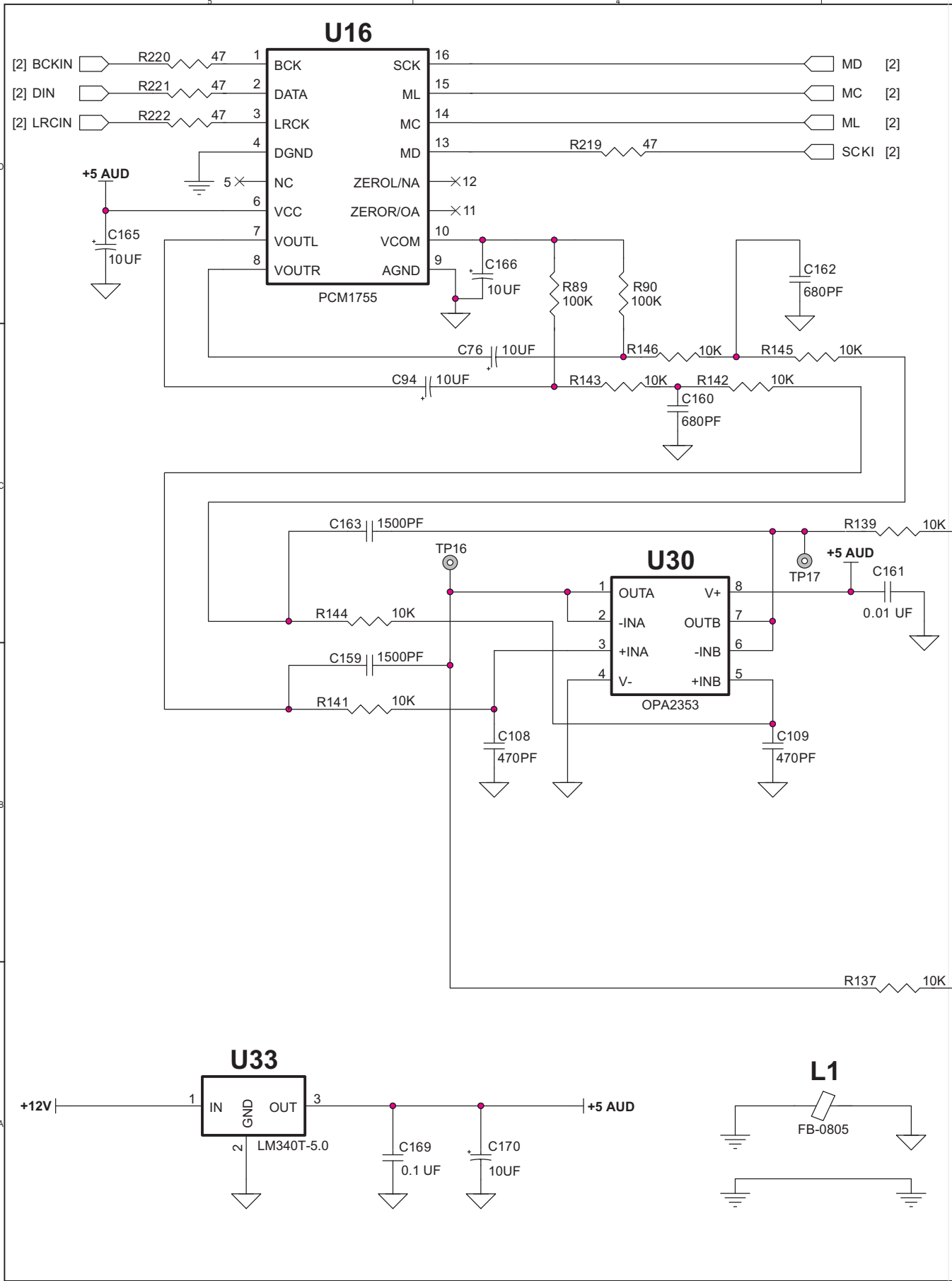

Sec. 5: PCBs



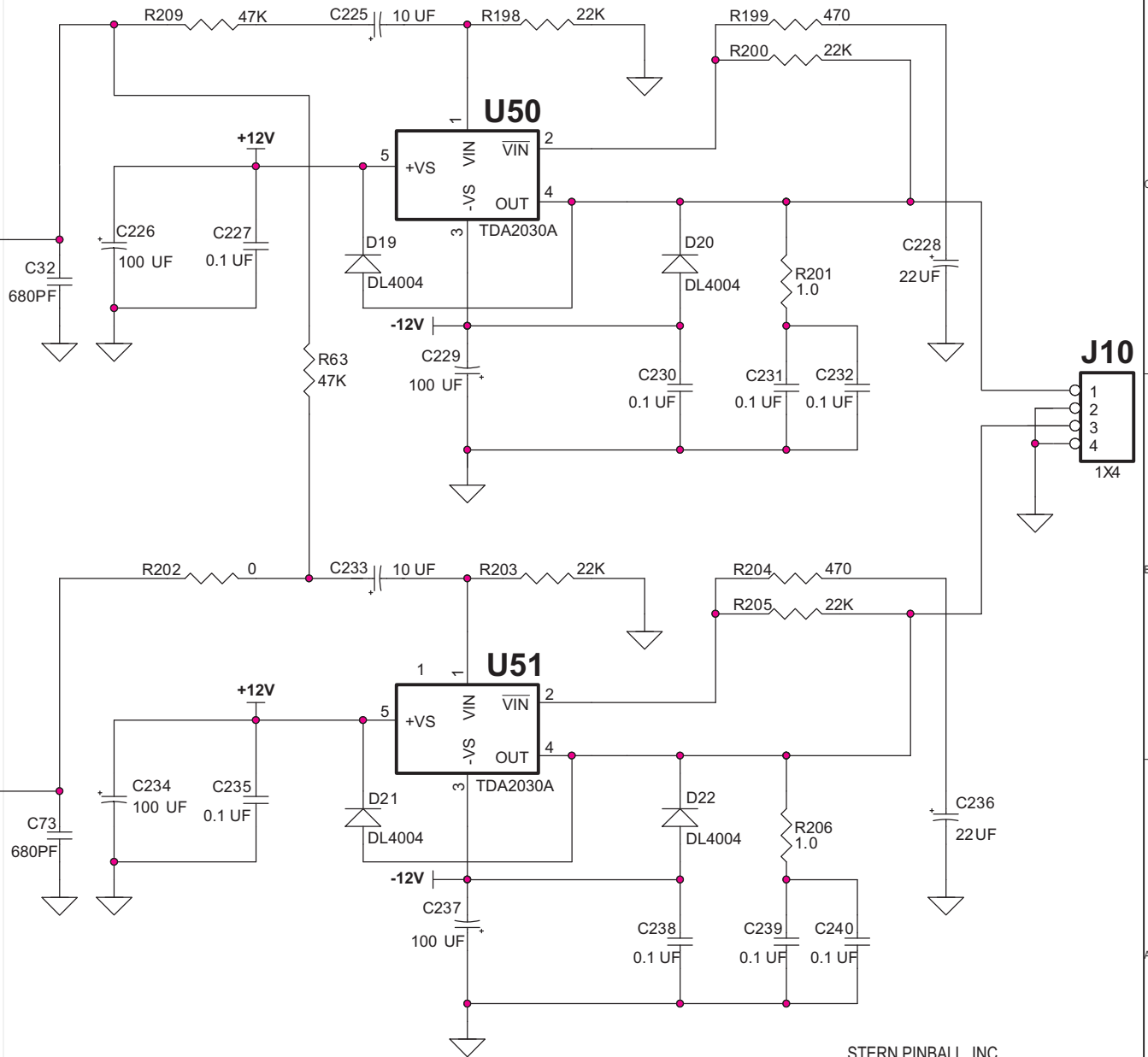

STERN PINBALL, INC.
CPU / Sound PCB (S.A.M. System)
 520-5246-00 Sheet 3 of 5 Rev. G 041806

Sec. 5: PCBs



CPU / SOUND PCB S.A.M. System (520-5246-00) Component Layout

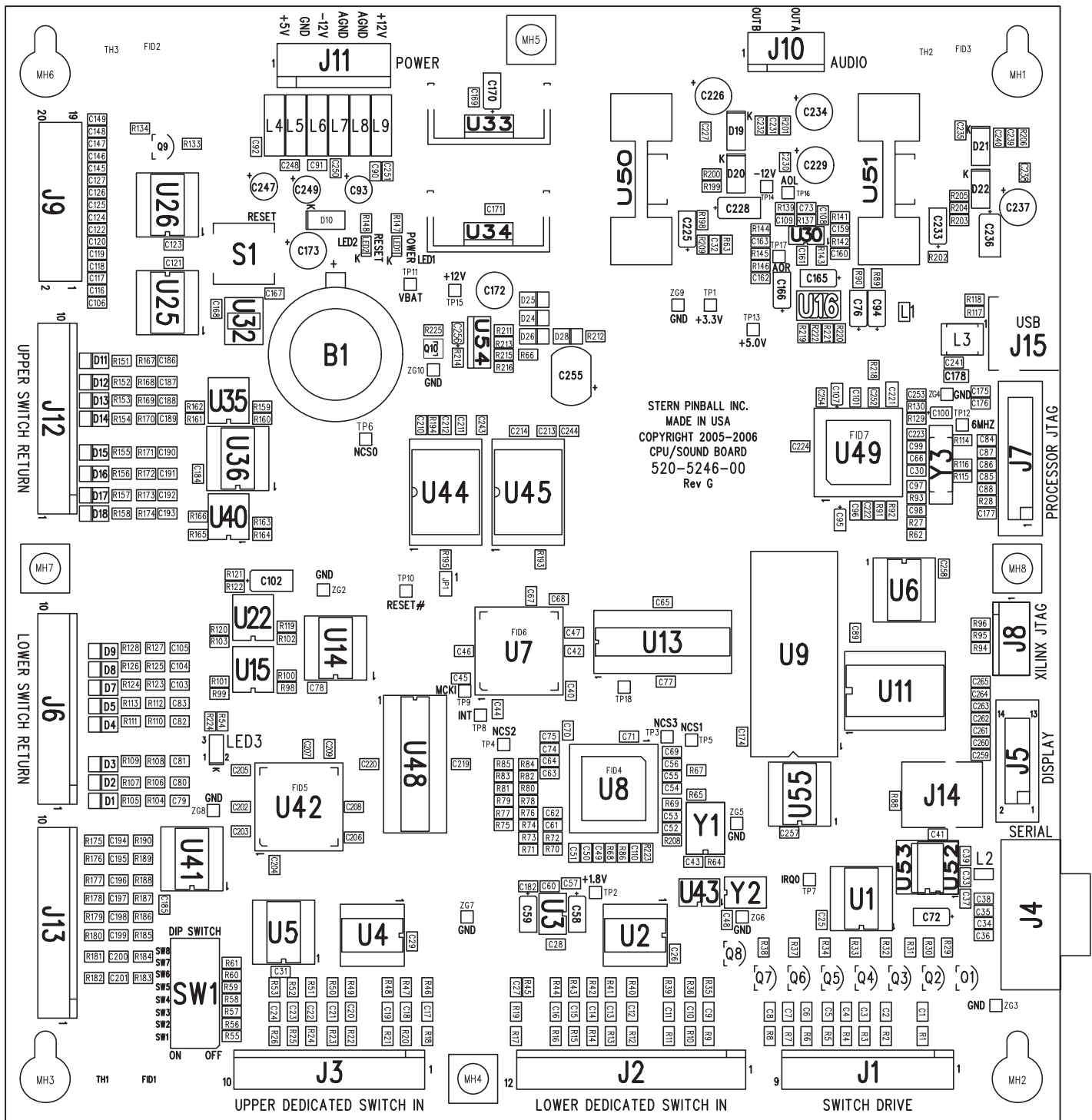

ITEM	QTY.	SPI PART NUMBER (MFG. P.N.)	REF-DESIGNATOR	DESCRIPTION (SM = Surface Mount)
1	1	520-5246-00	CPU/Sound PCB (S.A.M. System), Rev. G	(includes Items 1-90)
2	3	121-6017-00	(101-0001790)	R27, R202, R212
3	2	121-6108-00	(101-0001792)	R201, R206
4	24	121-6001-00	(101-0001807)	R9, R10, R11, R12, R13, R14, R15, R16, R18, R20, R21, R22, R23, R24, R25, R26, R175, R176, R177, R178, R179, R180, R181, R182, R147, R148, R211
5	3	121-6002-00	(101-0001820)	R64, R66, R67, R68, R70, R71, R72, R73, R74, R75, R76, R77, R78, R79, R80, R81, R82, R83, R84, R85, R89, R90, R92, R208
6	24	121-6019-00	(101-0001823)	R28, R65, R91, R98, R99, R100, R101, R102, R103, R119, R120, R134, R137, R139, R141, R142, R143, R144, R145, R146, R159, R160, R161, R162, R163, R164, R165, R166, R193, R194, R195, R223, R225
7	33	121-6020-00	(101-0001827)	R117, R118
8	2	121-6021-00	(101-0001880)	R117, R118

Sec. 5: PCBs



Parts List Continued Next Page.

CPU / SOUND PCB S.A.M. System (520-5246-00) Parts Continued

ITEM	QTY.	SPI PART NUMBER	(MFG. P.N.)	REF-DESIGNATOR	DESCRIPTION (SM = Surface Mount)
8	47	121-6022-00	(101-0001905)	R1, R2, R3, R4, R5, R6, R7, R8, R29, R30, R31, R32, R33, R34, R37, R38, R55, R56, R57, R58, R59, R60, R61, R94, R95, R96, R105, R107, R109, R111, R113, R114, R115, R116, R124, R126, R128, R133, R151, R152, R153, R154, R155, R156, R157, R158, R218, LED2	Resistor SM 0805 1KΩ 1/10W 5%
9	19	121-6004-00	(101-0001943)	R104, R106, R108, R110, R112, R123, R125, R127, R167, R168, R169, R170, R171, R172, R173, R174, R213, R214, R215	Resistor SM 0805 Film 220Ω 1/10W 5%
10	4	121-6005-00	(101-0001849)	R198, R200, R203, R205	Resistor SM 0805 Film 22KΩ 1/10W 5%
11	5	121-6023-00	(101-0001889)	R45, R86, R88, R121, R122	Resistor SM 0805 3.3KΩ 1/10W 5%
12	3	121-6024-00	(101-0002009)	R69, R129, R130	Resistor SM 0805 33Ω 1/10W 5%
13	2	121-6006-00	(101-0002012)	R54, R93	Resistor SM 0805 Film 330Ω 1/10W 5%
14	24	121-6013-00	(101-0002035)	R35, R36, R39, R40, R41, R42, R43, R44, R46, R47, R48, R49, R50, R51, R52, R53, R183, R184, R185, R186, R187, R188, R189, R190	Resistor SM 0805 Film 39KΩ 1/10W 5%
15	2	121-6008-00	(101-0002046)	R17, R19	Resistor SM 0805 Film 4.7KΩ 1/10W 5%
16	4	121-6014-00	(101-0002065)	R219, R220, R221, R222	Resistor SM 0805 Film 47Ω 1/10W 5%
17	3	121-6025-00	(101-0002067)	R199, R204, R216	Resistor SM 0805 470Ω 1/10W 5%
18	1	121-6015-00	(101-0002071)	R209	Resistor SM 0805 Film 47KΩ 1/10W 5%
19	99	125-6001-00	(121-0000056)	C25, C26, C27, C29, C31, C33, C37, C39, C40, C41, C42, C43, C44, C45, C46, C47, C48, C51, C52, C54, C62, C64, C65, C67, C68, C69, C71, C75, C77, C78, C79, C80, C81, C82, C83, C89, C90, C91, C92, C103, C104, C105, C121, C123, C168, C169, C171, C174, C175, C176, C177, C182, C184, C185, C186, C187, C188, C189, C190, C191, C192, C193, C202, C203, C204, C205, C206, C207, C208, C209, C210, C211, C212, C213, C214, C219, C220, C222, C223, C224, C227, C230, C231, C232, C235, C238, C239, C240, C241, C243, C244, C248, C250, C251, C252, C253, C254, C257, C258	Capacitor SM 0805 Cer. 1UF 50V 10% X7R
20	3	125-6013-00	(121-0000077)	C28, C57, C60	Capacitor SM 0805 Cer. 1UF 10V 10% X7R
21	1	125-6014-00	(121-0000086)	C97	Capacitor SM 0805 Cer. 3300PF 50V 5% X7R
22	7	125-6002-00	(121-0000096)	C259, C260, C261, C262, C263, C264, C265	Capacitor SM 0805 Cer. 470PF 50V 5% NPO
23	3	125-6015-00	(121-0000269)	C102, C228, C236	Capacitor SM Case D Tant 22UF 25V 20%
24	11	125-6003-00	(121-0004236)	C1, C2, C3, C4, C5, C6, C7, C8, C110, C161, C167	Capacitor SM 0805 Cer. 0.1UF 50V 10% X7R
25	49	125-6016-00	(121-0004245)	C9, C10, C11, C12, C13, C14, C15, C16, C17, C18, C19, C20, C21, C22, C23, C24, C49, C50, C53, C55, C56, C61, C63, C70, C74, C106, C116, C117, C118, C119, C120, C122, C124, C125, C126, C127, C145, C146, C147, C148, C149, C194, C195, C196, C197, C198, C199, C200, C201	Capacitor SM 0805 Cer. 47PF 50V 5% NPO
26	4	125-6017-00	(121-0005317)	C95, C100, C107, C256	Capacitor SM Case A Tant 2.2UF 16V 10%
27	6	125-6004-00	(121-0005318)	C30, C34, C35, C36, C38, C66	Capacitor SM 0805 Cer. 22PF 100V 5% NPO
28	2	125-6005-00	(121-0006113)	C178, C221	Capacitor SM 1206 Cer. 4.7PF 16V 20% Y5V
29	2	125-6006-00	(121-0007394)	C159, C163	Capacitor SM 603 Cer. 1500PF 25V 10% X7R
30	10	125-6007-00	(121-0007853)	C58, C59, C72, C76, C94, C165, C166, C170, C225, C233	Capacitor SM Case C Tant 10UF 16V 20%
31	1	125-6018-00	(121-0010097)	C98	Cap. SM 805 Cer. .033UF 50V +80/-20% Y5V
32	4	125-6009-00	(121-0010493)	C32, C73, C160, C162	Capacitor SM 805 Cer. 680PF 50V 5% NPO
33	6	125-6019-00	(134-0005415)	C172, C173, C226, C229, C234, C237	Capacitor Tht. Radial Alum. 100UF 35V 20%
34	3	125-6020-00	(134-0007336)	C93, C247, C249	Capacitor Tht. Radial Alum. 47UF 35V 20%
35	1	125-6010-00	(139-0006487)	C255	Capacitor Tht. .22UF 5.5V, Gold, SD, Vert
36	6	125-6011-00	(161-0004959)	L4, L5, L6, L7, L8, L9	Ind.-SM Ferrite 100Ω 1234 Smt.
37	2	125-6012-00	(161-0007286)	L1, L2	Ind.-SM 805 Bead 600Ω 100MHz 25% 500mA
38	1	125-6021-00	(161-0009686)	L3	Ind.-SM EP Inductor 15uH 1100mA 20%
39	20	125-6000-00	(181-0004347)	D1, D2, D3, D4, D5, D7, D8, D9, D11, D12, D13, D14, D15, D16, D17, D18, D24, D25, D26, D28, D10, D19, D20, D21, D22	Diode SM MiniMELFDL/LL4148 100V 500mW
40	5	112-6001-00	(181-0004478)	Q10	Diode SM MELF DL4004 400V 1.0A
41	1	110-6000-00	(201-0006808)	Q1	Fet-SM SOT-23 MMBF170 N-Chnnl. Fet
42	9	110-0069-00	(213-0003546)	Q1, Q2, Q3, Q4, Q5, Q6, Q7, Q8, Q9	Transistor Tht. TO-92 2N3904 NPN 40V 0.2A
43	1	124-6000-00	(213-0005687)	U34	Trans. Tht. TO-220 LT1086 3.3V 1.5A Volt Reg.
44	8	100-6004-00	(221-0001000)	U2, U4, U5, U14, U25, U26, U36, U41	I.C.-SM SO 74LVC245 Oct. Bus Xcvr.
45	1	100-5048-00	(221-0003716)	U55	I.C.-SM SOIC 74HCT245DW Octal Line Xvr. W/3S
46	4	100-6005-00	(221-0003718)	U15, U22, U35, U40	I.C.-SM SO LM339 Quad Diff. Comp.
47	1	100-6006-00	(221-0005249)	U43	I.C.-SM SOIC DS1302 Time Keeper
48	1	100-6008-00	(221-0006578)	U52	I.C.-SM SOIC SP232A SO-16
49	1	100-6009-00	(221-0006914)	U32	I.C.-SM SOT-223 DS1233A2-15 Reset
50	1	100-6007-00	(221-0006919)	U30	I.C.-SM OPA2353 Dual CMOS OpA MSOP-8
51	1	100-6018-00	(221-0006940)	U48	I.C.-SM SOJ IDT71V016SA15Y SOJ-44
52A	1	100-6016-00	(221-0007056)	U7 (must be programmed)	U7 (I.C.-SM TQFP CPLD 144 Macro Cell 3.3V)
52B	1	100-6017-00	(221-0007056)	U42 (must be programmed)	U42 (I.C.-SM TQFP CPLD 144 Macro Cell 3.3V)
53	1	124-6001-00	(221-0007298)	U3	I.C.-SM SOIC LT1503CS8-1.8
54	1	100-6012-00	(221-0010735)	U11	I.C.-SM SOIC CY62128 SRAM 128Kx8 3V LP SO32
55	1	100-6013-00	(221-0010736)	U49	I.C.-SM QFP-L AT43 USB380 Processor USB 2.0
56	1	100-6014-00	(221-0010738)	U16	I.C.-SM SSP PCM1755 24-Bit Audio DAC 16-Pi
57	1	100-6010-00	(221-0010978)	U13	I.C.-SM SOJ IDT71V416S15Y SOJ-44
58	1	100-6011-00	(221-0010981)	U44	I.C.-SM T50P S29GL256N11 256MB Flash
59	1	100-6015-00	(221-0011102)	U1	I.C.-SM SOIC 74LV273 SOIC-20
60	1	124-6002-00	(225-0003581)	U54	I.C.-Tht. TO-220 LM317T Adjustable Volt Reg.
61	2	100-5016-20	(225-0003635)	U50, U51	I.C.-Tht. Pentawat TDA2030 18W Amplifier
62	1	124-6003-00	(225-0006921)	U33	I.C.-Tht. TO-220 LM340T 5V 1A Volt Regulator
63	1	077-5217-00	(301-0004285)	SU9	Socket DIP/SIP 32-Pin, Tin, .6, Dip
64	2	n/a	(303-0005944)	TP1, TP2	Test Pt. All Test Point, White, Miniature
65	1	045-	(315-0003511)	JP1	Con.-Tht. Header 2 Pin, 1 Row, VT, Tin, .1"
66	1	045-	(315-0004097)	J11	Con.-Tht. Header 6 Pin, 1 Row, VT, Tin, .156"
67	1	045-	(315-0004121)	J1	Con.-Tht. Header 9 Pin, 1 Row, VT, Tin, .156"
68	4	045-	(315-0004122)	J3, J6, J12, J13	Con.-Tht. Hdr. 10 Pin, 1 Row, VT, Tin, .156"
69	1	045-	(315-0004124)	J8	Con.-Tht. Header 6 Pin, 1 Row, VT, Tin, .1"
70	1	045-	(315-0006776)	J14	Con.-Tht. Hdr. 6 Pos. Phone Jack, Vertical
71	1	045-	(315-0006910)	J9	Con.-Tht. Header 20 Pin, 2 Row, VT, Tin, .1"
72	1	045-	(315-0009252)	J10	Con.-Tht. Header 4 Pin, 1 Row, VT, Tin, .156"
73	1	045-	(315-0009520)	J2	Con.-Tht. Hdr. 12 Pin, 1 Row, VT, Tin, .156"
74	1	045-	(315-0009626)	J15	Con.-Tht. 4 Pos. USB Recept, VT, WHT/BLK
75	1	045-	(315-0009627)	J4	Con.-Tht. D-Sub 9 Pos, VT, w/lock & Hex Sc.
76	1	045-	(315-0010979)	J5	Con.-Tht. Hdr. 14 Pin, 2 Row, VT, Gold, .1" Shrou.
77	1	140-6000-00	(401-0007295)	Y2	XTAL -SM 32.768MHz Cl 12.5 FSR327
78	1	140-6001-00	(401-0010737)	Y3	XTAL -SM 600MHz 20PF
79	1	140-6002-00	(403-0005489)	Y1	Osc.-SM SO 400MHz 5V Tristate CMOS
80	1	515-	(421-0010979)	B1	Battery (Coin Cell 24.5mm) Holder with clip
81	1	000-0644-01	(421-0010980)	for B1	Coin Cell 3V 265mAh 24X3 mm (CR2430)
82	1	165-6003-00	(425-0005320)	LED1	LED SM Green 0805 LED
83	1	165-6004-00	(425-0010803)	LED3	LED SM Dual Red/Green 1210 Top
84	1	182-5002-00	(450-0004750)	SW1	8-Position Dip Switch
85	1	182-5001-00	(450-0004752)	S1	Spst. 16 Pin X8 Slide 5VDC 100ma White Push-Button Reset Switch Spst. 4 Pin Momentary 24VDC 50ma
86	2	127-5001-00	(461-0003520)	for U33, U34	Heatsink All Vert Mount Ba TO-220
87	2	127-5001-01	(461-0003528)	for U50, U51	Heatsink All Vert Mount Ba TO-220
88	4	237-5909-01	(504-0004604)	for Heat Sinks U33, U34, U50, U51	#4-40 X 3/8" PPH MS Sems (Zinc) Screw
89	4	240-5318-00	(503-0004457)	for Heat Sinks U33, U34, U50, U51	#4-40 Keps Nut
90	4	254-5007-05	(507-0004547)	for Mntg. Holes (Mfg. .169" I.D. X 9/32" O.D. X 5/16")	5/16" Sif. Rtn. Spacer White

Sec. 5: PCBs

Display Power Supply PCB (520-5138-00) Schematic

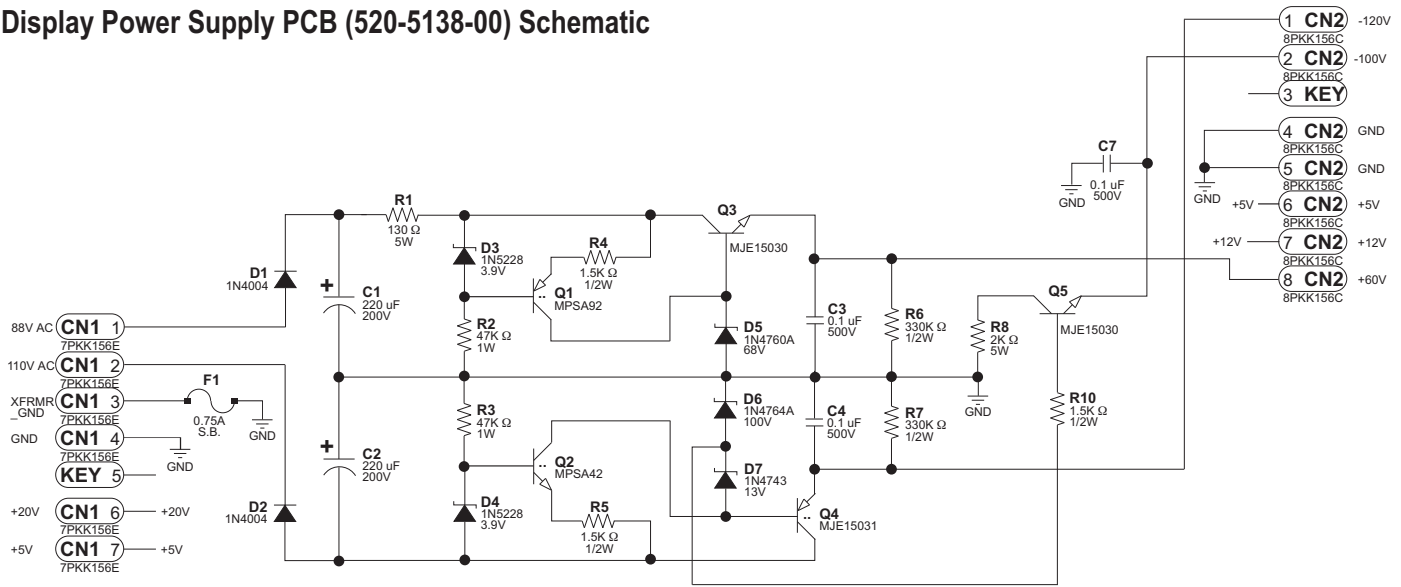

Display Power Supply PCB (520-5138-00) Component Layout & Parts

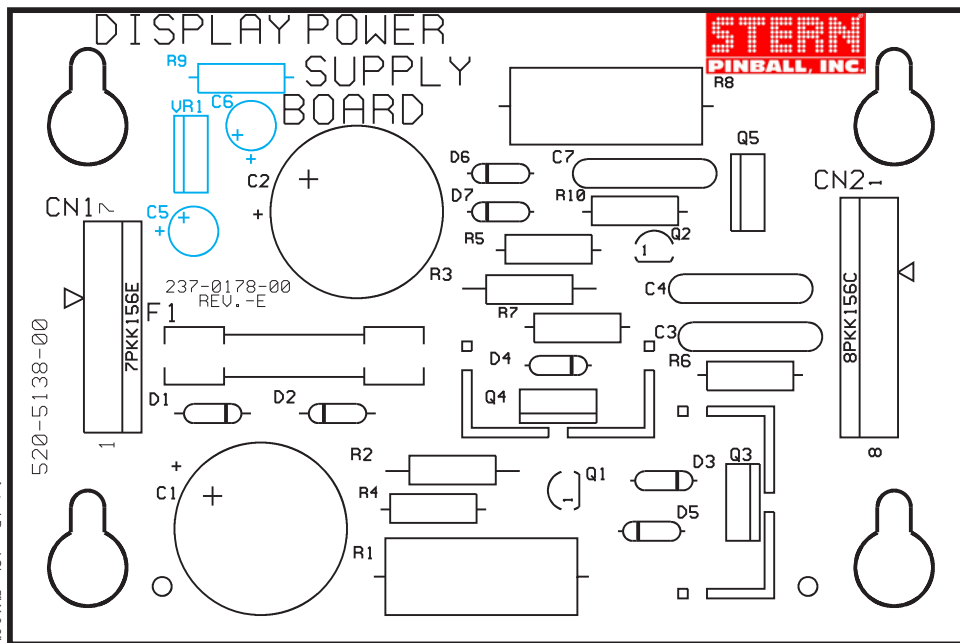

ITEM	QTY	PART NUMBER	REF-DESIGNATOR	DESCRIPTION (NS = Not Stuffed)
—	1	520-5138-00	Display Power Supply PCB	<i>(includes Items 1-2 + 4-24)</i>
1	2	125-5044-00	C1, C2	220uF, 200v, Radial Lytic Cap.
2	3	125-5035-00	C3, C4, C7	0.1uF, 500v, Ceramic Disk Cap.
3	0	125-5003-00	(C5, C6: NS)	22uF, 35v, Rad Lytic Cap
4	1	045-5015-07	CN1	7PKK156E (PIN5=KEY)
5	1	045-5015-08	CN2	8PKK156 (PIN3=KEY)
6	2	112-5003-00	D1, D2	1N4004, Diode
7	2	112-0053-00	D3, D4	1N5228, 3.9v, Diode
8	1	112-0062-00	D5	1N4760A, 68v, Diode
9	1	112-0049-00A	D6	1N4764A, 100v, Diode
10	1	112-0061-00	D7	1N4743, 13v, Diode
11	1	200-5000-17	F1	3/4A (0.75A) S.B. Fuse
12	2	205-0004-00	F1	Fuse Clip
13	1	110-0100-00	Q1	MPSA92, Transistor
14	1	110-0082-00	Q2	MPSA42, Transistor
15	2	110-0101-00	Q3, Q5	MJE15030, Transistor
16	2	535-5000-11	Q3, Q4	Heatsinks - AAVID #563002
17	2	240-5008-00	Q3, Q4	#6-32 KEPS Nut
18	2	237-5501-00	Q3, Q4	#6-32 X 3/8" PPH Screw
19	1	110-0103-00	Q4	MJE15031, Transistor
20	1	121-5061-00	R1	130 Ω Resistor SMT, 5W
21	2	121-5060-00	R2, R3	47K Ω Resistor SMT, 1W
22	3	121-5038-00	R4, R5, R10	1.5K Ω Resistor SMT, 1/2W (R9: NS)
23	2	121-5059-00	R6, R7	330K Ω Resistor SMT, 1/2W
24	1	121-5062-00	R8	2K Ω Resistor SMT, 5W
25	0	124-5003-00	(VR1: NS)	7812CT

Sec. 5: PCBs



Playfield Switches OPTO Transceiver PCBs (500-6775-00 & -01) Schematic

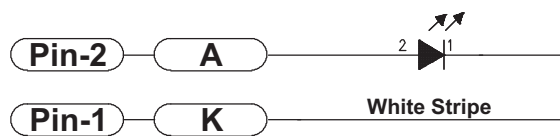

**Mini PCB
OPTO 12"/15" Lead
(Black Bracket)
500-6775-00/-01**

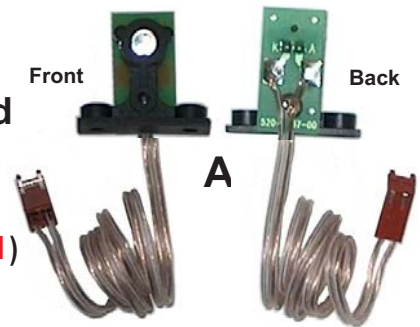

Playfield Switches OPTO Transceiver PCBs (500-6775-00 & -01) Component Layout & Parts

ITEM	QTY	PART NUMBER	REF-DESIGNATOR	DESCRIPTION
A, B & D	3 pair	500-6775-00		Mini OPTO Transceiver PCB Assembly (Items A PCB + B + C)
A, C & D	1 pair	500-6775-01		Mini OPTO Transceiver PCB Assembly (Items A PCB + B + C)
A	1	520-5237-00		Mini OPTO Transceiver PCB
A-1	1	545-6092-00		(includes Items A-1 – A-3)
A-2	1	237-5909-00		Black Bracket (Plastic) Holder
A-3	1	165-5052-00		#4-40 X 1/4 PPH Screw
B	1	601-5023-12	K, A	LED (Ultra Bright Red)
C	1	601-5023-15	K, A	12" Speaker Wire (1-Side White Stripe)
D	1	045-5020-02	Note White Strip to Pin-1	15" Speaker Wire (1-Side White Stripe)
				2-Pin Cn., .100 KK Cmp Trm Molex 08-50-0113

Playfield OPTO Transmitter / Receiver Amplifier PCB (520-5239-01) Schematic

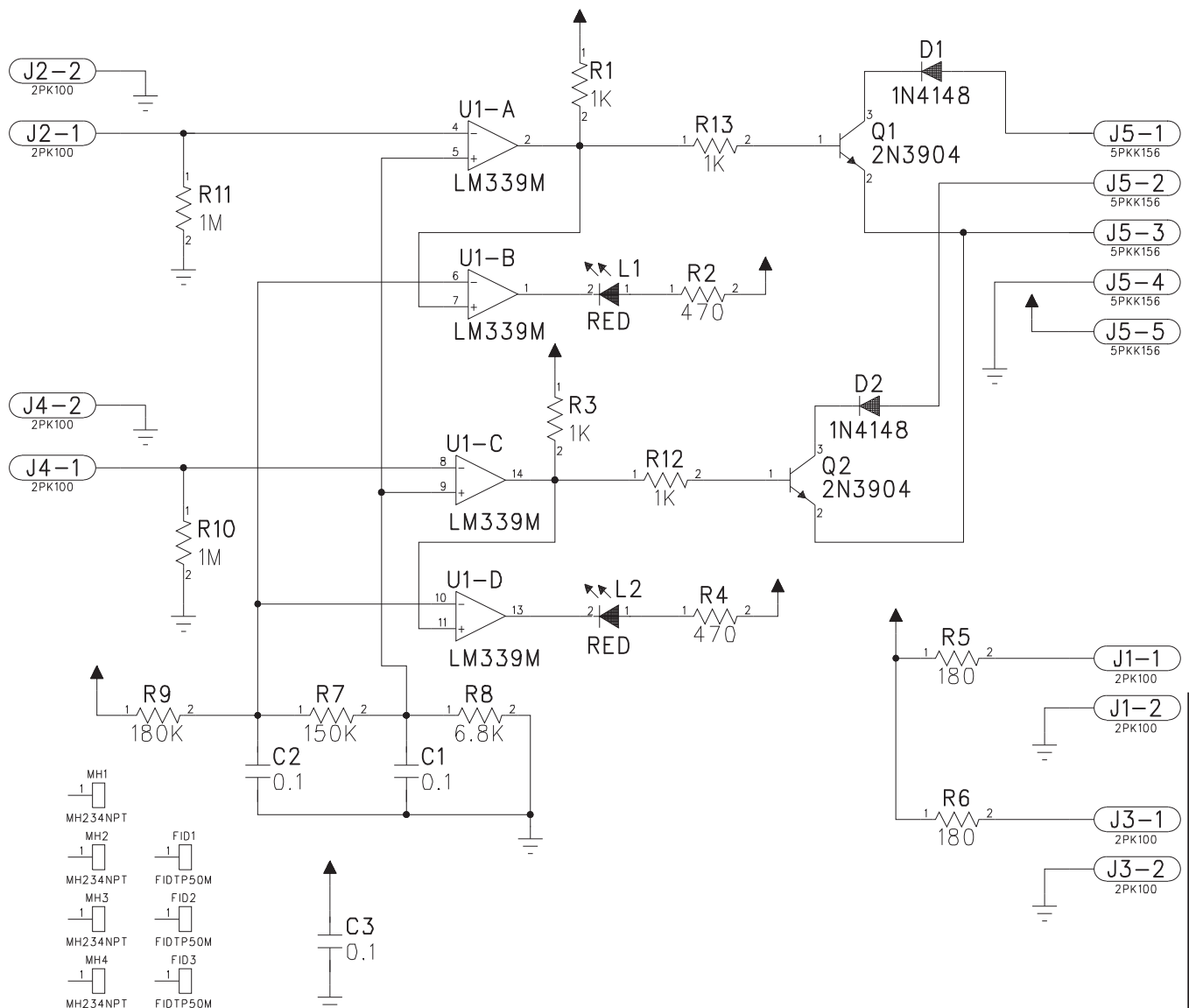

Sec. 5: PCBs

Playfield OPTO Transmitter/Receiver Amplifier PCB (520-5239-01) Component Layout & Parts

(for OPTO Switches 52 – 55)

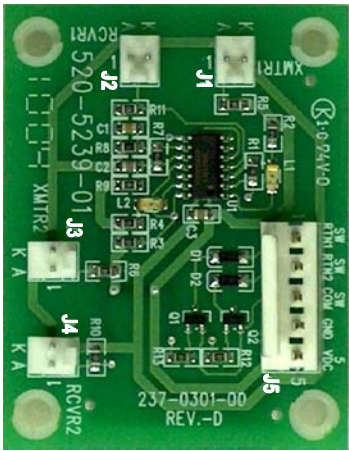

Front

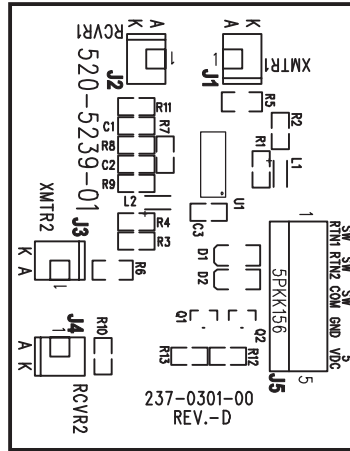

Front

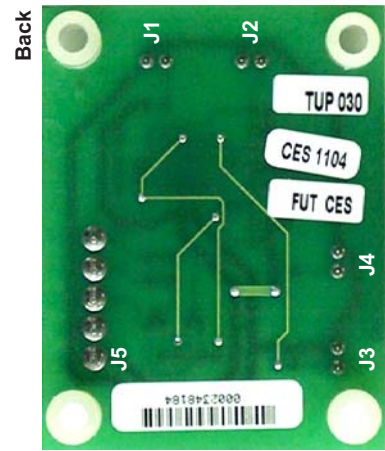

Back

ITEM	QTY	PART NUMBER	REF-DESIGNATOR
1	2	520-5239-01	OPTO Transmitter/Receiver Amplifier PCB
2	1		R7
3	2		R5, R6
4	1		R9
5	4	<i>If a part is required where a part number is not provided, call Technical Support (see back of cover).</i>	R1, R3, R12, R13
6	2		R10, R11
7	2		R2, R4
8	1		R8
9	3		C1, C2, C3
10	2		D1, D2
11	2		Q1, Q2
12	1		U1
13	4	Mfg. 22-23-2021	J1, J2, J3, J4
14	1	Mfg. 640445-5	J5
15	2	Mfg. APT3216SURC	L1, L2
	4		n/a

DESCRIPTION

(incl. Items 1–14 + Item 15 spacers)
 SMT 150K Ω 1/10W Resistor 805, 5%
 SMT 180 Ω 1/10W Resistor 805, 5%
 SMT 180K Ω 1/10W Resistor 805, 5%
 SMT 1K Ω 1/10W Resistor 805, 5%
 SMT 1M Ω 1/10W Resistor 805, 5%
 SMT 470 Ω 1/10W Resistor 805, 5%
 SMT 6.8K Ω 1/10W Resistor 805, 5%
 SMT Cer. .1uF 50v Cap., 10% X7R
 1N4148W, Diode, 100v, 350MW
 MMST3904, NPN, 40v, .02A
 LM339M, Low Power Offset QUA
 2-Pin, 0.1 Header (1 Row, VT, Tin)
 5-Pin, .156 Header (1 Row, VT, Tin)
 LEDD-SMT, Red 1206
 Spacer (Nylon), .153" ID X 9/32" OD X 3/8"

Playfield OPTO Transmitter/Receiver Amplifier PCB (520-5239-01) Wiring (General)

(for PCB 1: OPTO Switches 52 & 53 /// PCB 2: OPTO Switches 54 & 55)

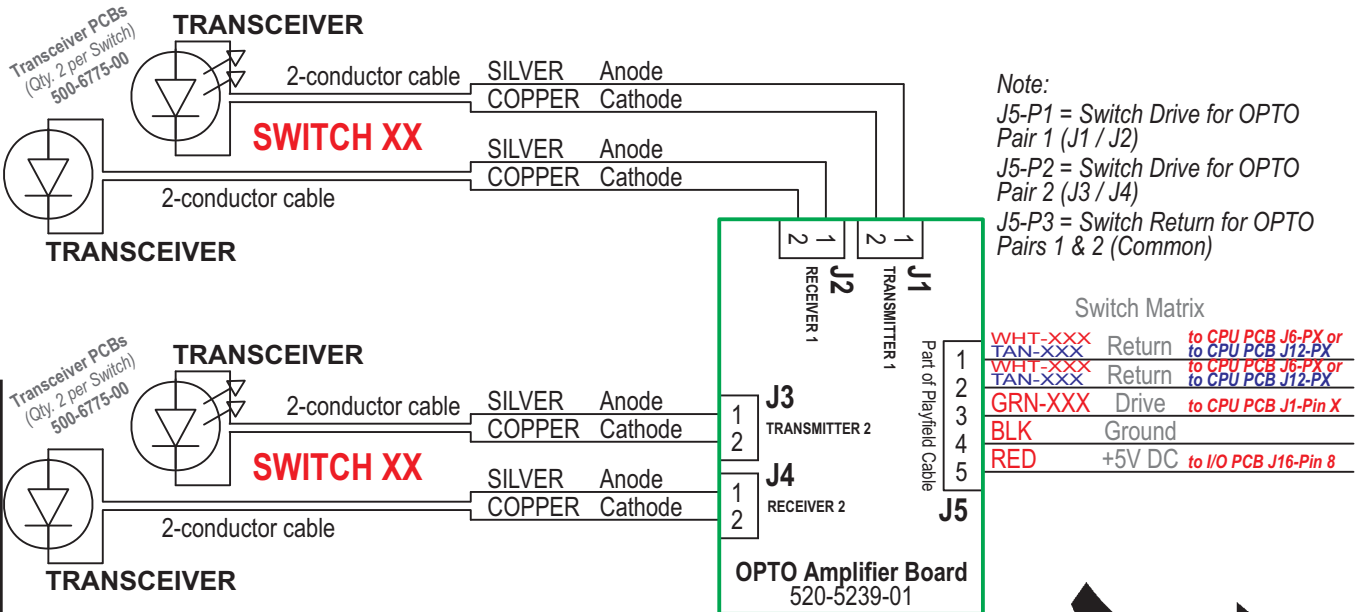

For details on Board Wiring Configuration for PCBs 1 – 2, see opposite pages.



Sec. 5: PCBs



Playfield OPTO Transmitter/Receiver Amplifier PCB (520-5239-01) Wiring (Game Specific)
PCB 1: OPTO Switches 52 [Mini-Playfield Right Orbit] & 53 [Mini-Playfield Left Orbit]

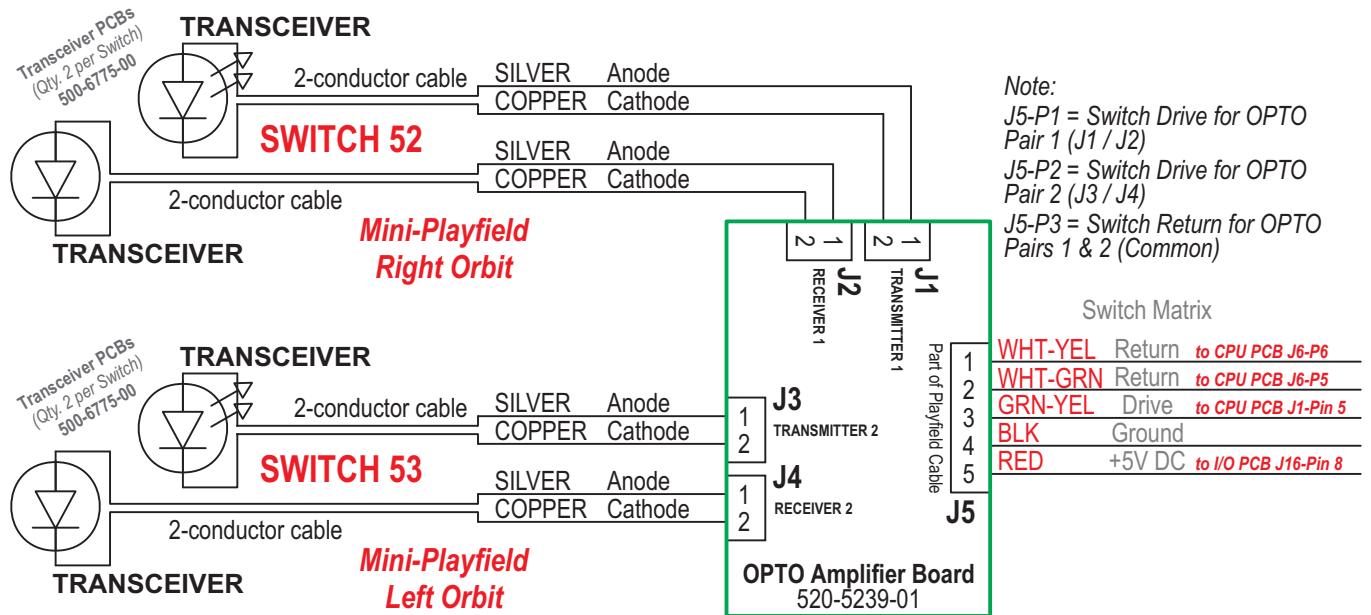

Playfield OPTO Transmitter/Receiver Amplifier PCB (520-5239-01) Wiring (Game Specific)
PCB 2: OPTO Switches 54 [Mini-Playfield Mini-Ramp] & 55 [Mini-Playfield Mini-Shooter]

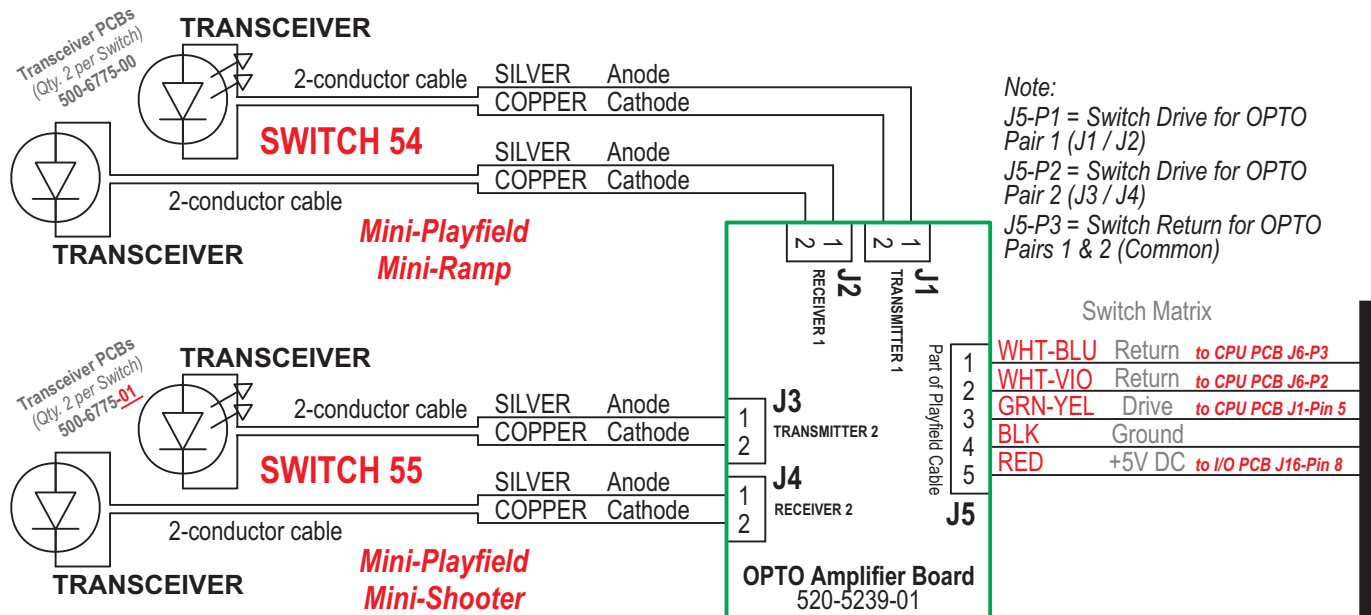

Sec. 5: PCBs

OPTO Interrupter PCB (520-5252-04) Schematic (4-Bank Drop Target)
 (for OPTO Switches 44 – 47)

*U-Shaped X4 OPTO
 Located on the 4-Bank Assembly*
PLAYFIELD HARNES
4-BANK DROP TARGET

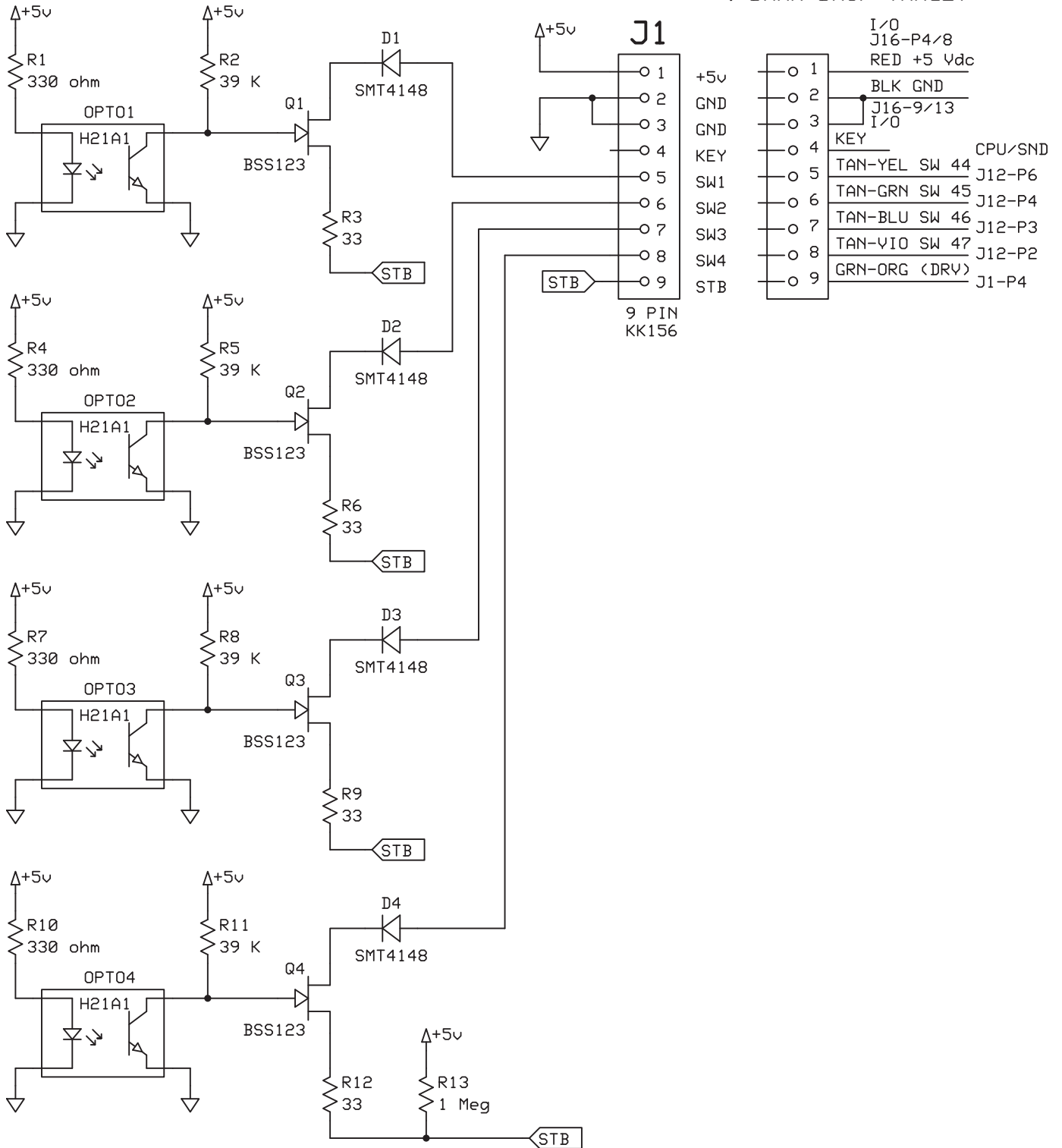

Sec. 5: PCBs

(Component Layout & Parts Next Page)



OPTO Interrupter PCB (520-5252-04) Component Layout & Parts (4-Bank Drop Target)

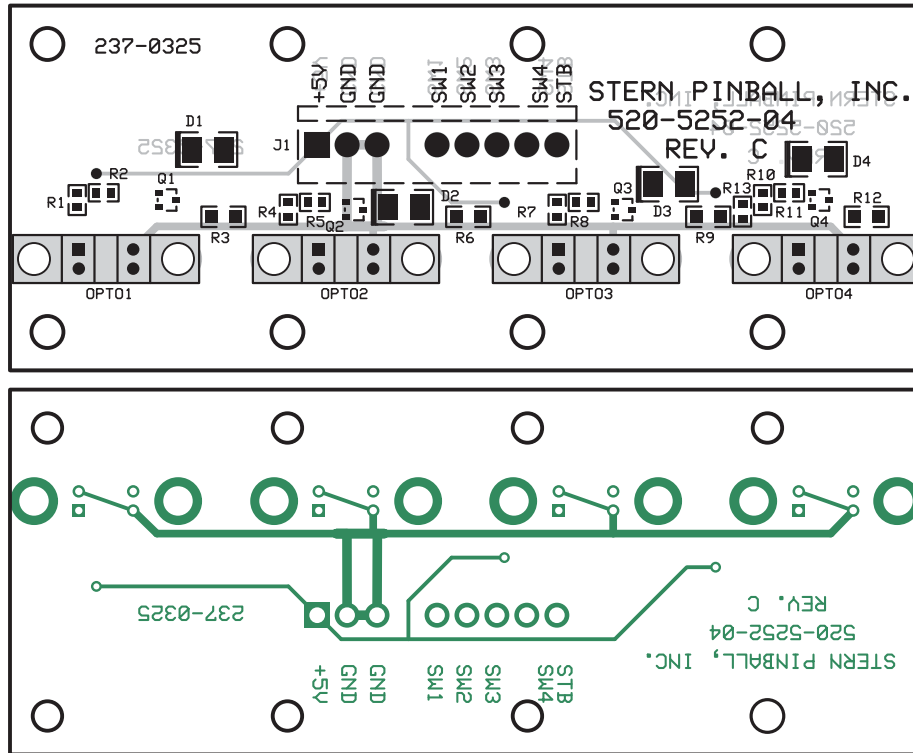

ITEM	QTY	PART NUMBER	REF-DESIGNATOR	DESCRIPTION
—	1	520-5252-04	4-Bank OPTO Interrupter PCB	<i>(includes Items 1–6)</i>
1	4	112-	D1, D2, D3, D4	1N4148W, Diode, 100v, 350mW SMT
2	4	<i>If a part is required where a part number is not provided, call Technical Support (see back of cover).</i>	OPTO1, OPTO2, OPTO3, OPTO4	H21A1 Slotted Optical Switch (OPTO)
3	4		Q1, Q2, Q3, Q4	BSS123 MOSFET Transistor 100v 6Ω
4	3		R1, R4, R7 (note diff. between 520-5252-01 & 520-5252-04)	330 Ω Resistor SMT
5	3		R2, R5, R8	39K Ω Resistor SMT
6	3	121-	R3, R6, R9	33 Ω Resistor SMT

Note: For the securing hardware of this PCB, see the 4-Bank Drop Target Assembly Drawing in Section 4, Chapter 2 (Blue Pages).

OPTO Interrupter (520-5252-01) Schematic, Component Layout & Parts (1-Bank Drop Target) (for OPTO Switch 9)

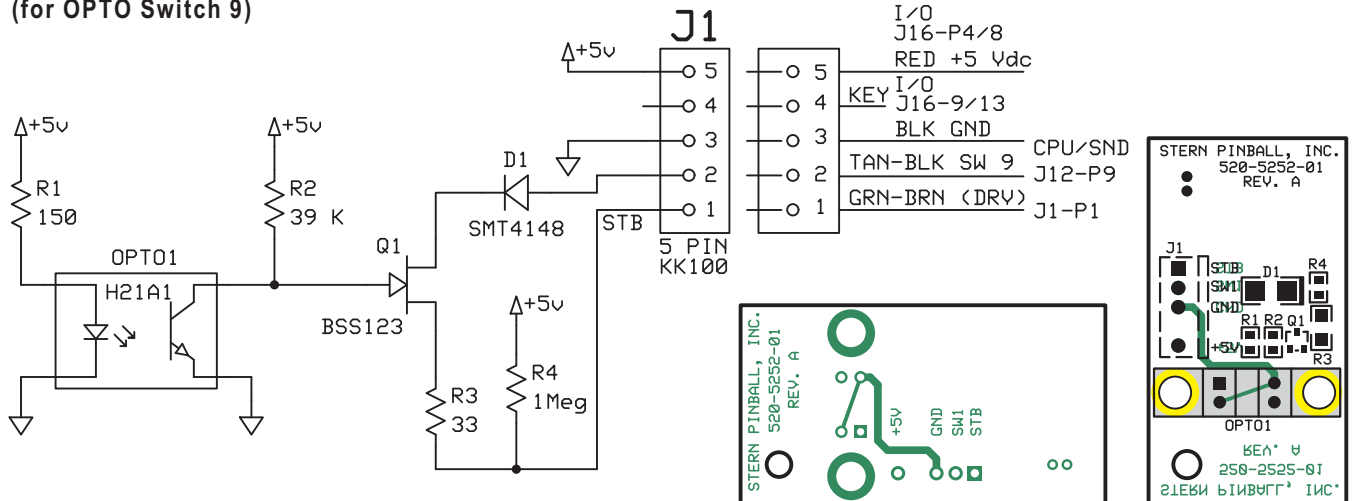

ITEM	QTY	PART NUMBER	REF-DESIGNATOR	DESCRIPTION
—	1	520-5252-01	1-Bank OPTO Interrupter PCB	<i>(includes Items 1–6)</i>
1	1	112-	D1	1N4148W, Diode, 100v, 350mW SMT
2	1	<i>If a part is required where a part number is not provided, call Technical Support (see back of cover).</i>	OPTO1	H21A1 Slotted Optical Switch (OPTO)
3	1		Q1	BSS123 MOSFET Transistor 100v 6Ω
4	1		R1 (note difference between 520-5252-01 & 520-5252-04)	150 Ω Resistor SMT
5	1		R2	39K Ω Resistor SMT
6	1	121-	R3	33 Ω Resistor SMT

Note: For the securing hardware of this PCB, see the 1-Bank Drop Target Assembly Drawing in Section 4, Chapter 2 (Blue Pages).

Mini-Playfield Lamp PCB (520-5264-00) Schematic

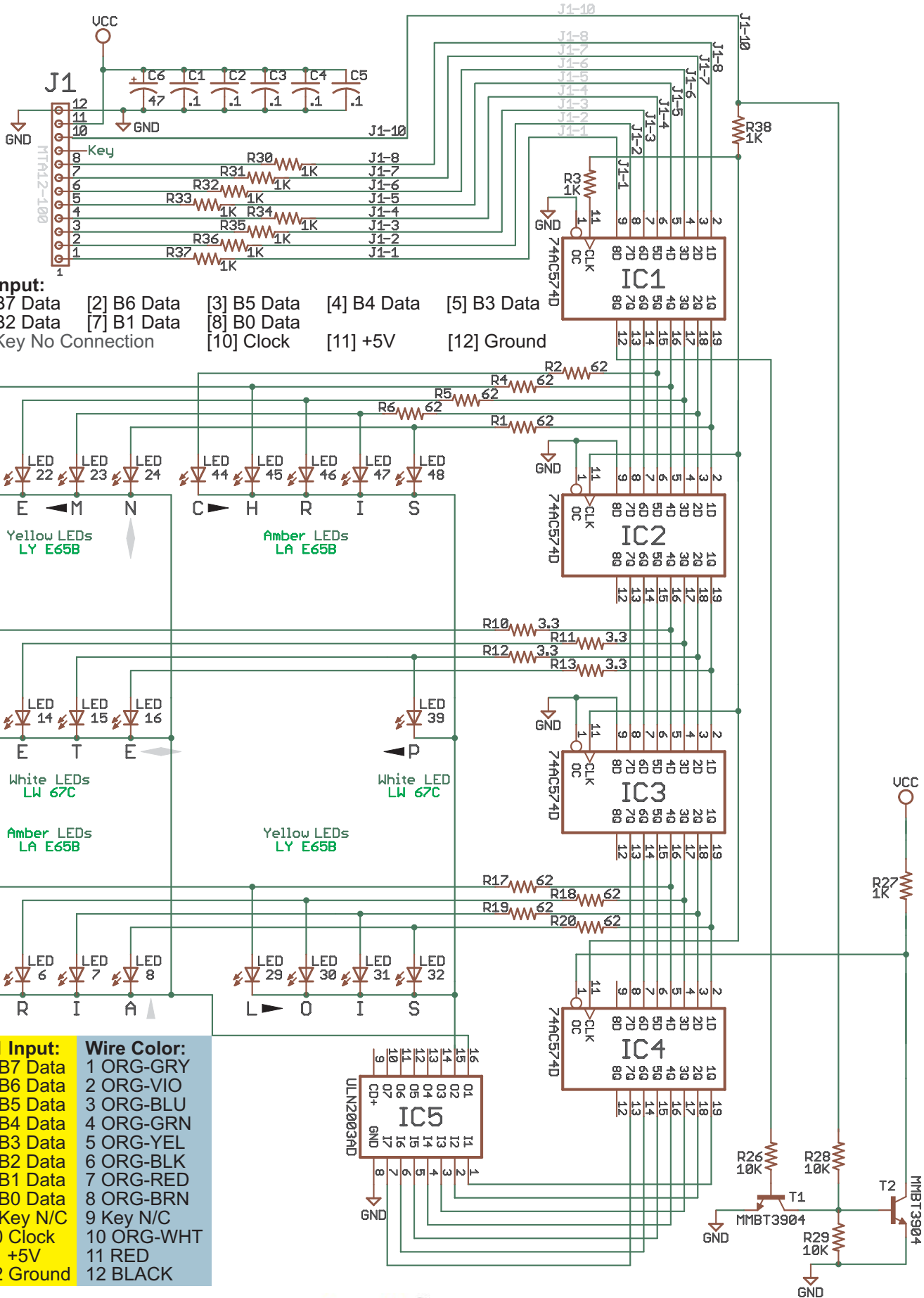

Sec. 5: PCBs



Mini-Playfield Lamp PCB (511-5046-00) Component Layout & Parts

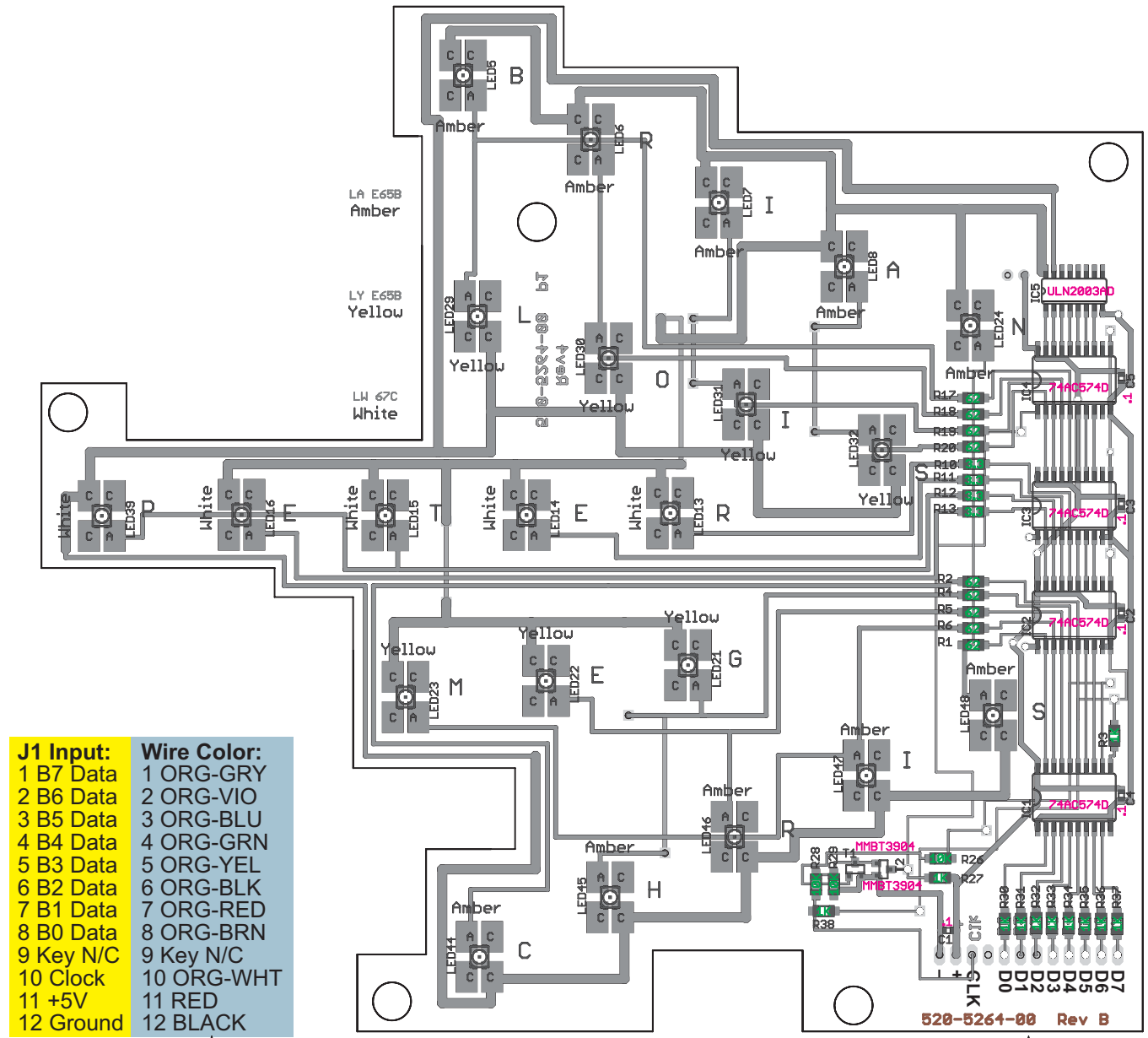

ITEM	QTY	PART NUMBER	REF-DESIGNATOR	DESCRIPTION (value, device)
A-B	1	511-5046-00	Mini-Playfield LED Lamp PCB Assembly (Items A PCB + Items B Spacers)	
A	1	520-5264-00	Mini-Playfield LED Lamp PCB	(includes Items A-1 – A-12)
A-1	11		R3, R27, R30, R31, R32, R33, R34, R35, R36, R37, R38	1K Ω Resistor SMT, R-US_R1206W
A-2	4		R10, R11, R12, R13	3.3 Ω Resistor SMT, R-US_R1206W
A-3	3		R26, R28, R29	10K Ω Resistor SMT, R-US_R1206W
A-4	9		R1, R2, R4, R5, R6, R17, R18, R19, R20	62 Ω Resistor SMT, R-US_R1206W
A-5	4		IC1, IC2, IC3, IC4	74ACT574D SMD
A-6	10		LED5, LED6, LED7, LED8, LED24, LED44, LED45, LED46, LED47, LED48	LED Amber Omron LA E65B, LEDP-LCC-4
A-7	5		LED13, LED14, LED15, LED16, LED39	LED White Omron LW 67C, LEDP-LCC-4
A-8	7		LED21, LED22, LED23, LED29, LED30, LED31, LED32	LED Yellow Omron LY E65B, LEDP-LCC-4
A-9	2		T1, T2	MMBT3904 Transistor, NPN SOT23 BEC
A-10	1		IC5	ULN2003AD Transistor
A-11	1		C6	22uF Capacitor, CPOL-USE2.5-6
A-12	5		C1, C2, C3, C4, C5	.1uF Capacitor, C-USC0603
A-13	1		J1	1-640457-2 Right Angle Header
B	5	254-5007-02		Spacer, Slf. Rtn. 1/4" White

Items A+ B secured to playfield by #6 X 3/4" SHWH AB (Zinc) (Qty. 1/per) (234-5003-00)



Stepper Motor Controller PCB (520-5261-00) Schematic

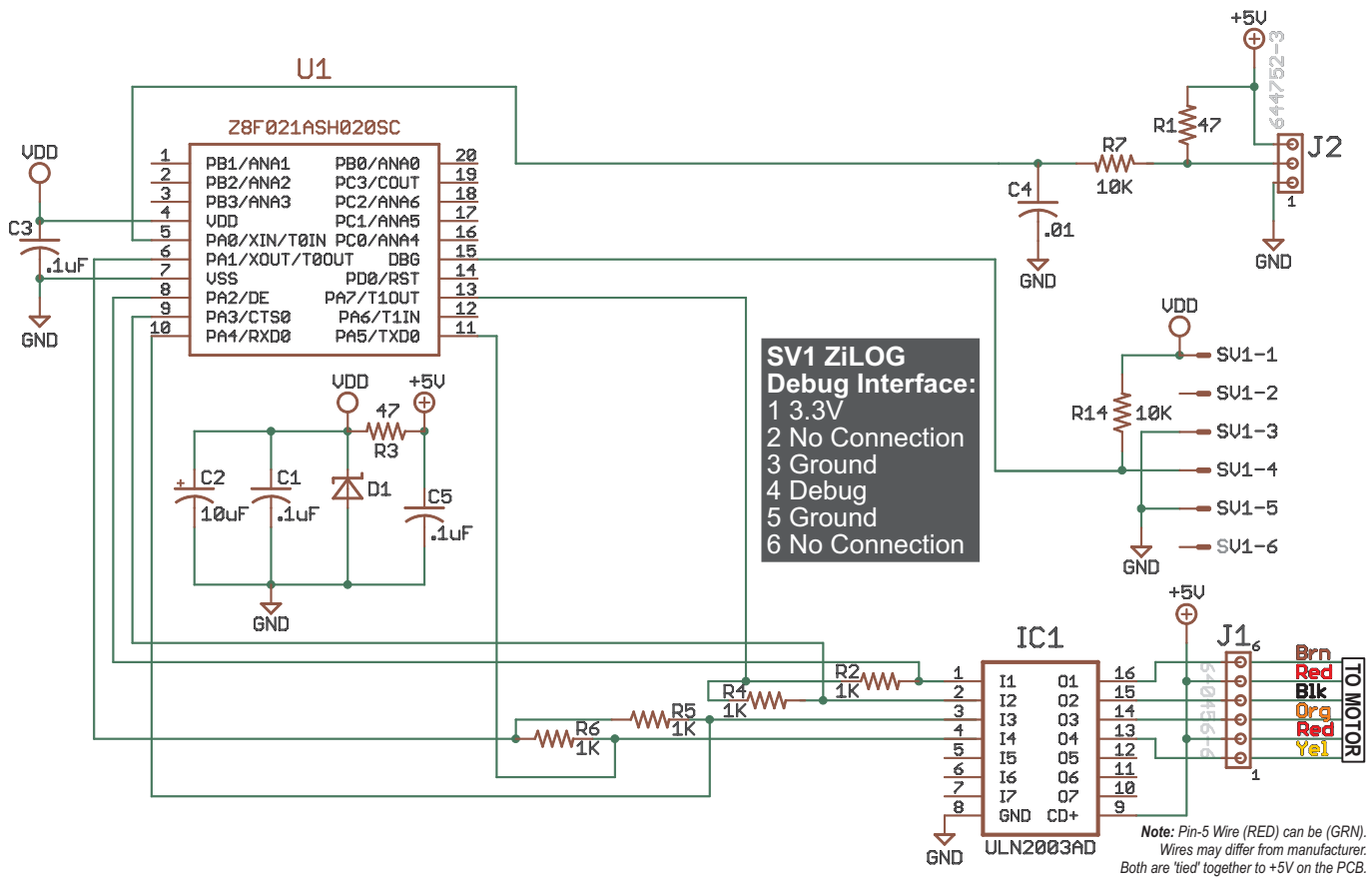

Stepper Motor Controller PCB Assembly (511-5045-00) Component Layout & Parts

J1 Motor Drive Wiring:

- 1 Motor Yellow
- 2 Motor Red (+5V)
- 3 Motor Orange
- 4 Motor Black
- 5 Motor Red (+5V)
- 6 Motor Brown

J2 Input Wiring:

- 1 Ground BLK
- 2 Coil Drive Q20 VIO-WHT: I/O J7-P6
- 3 +5V RED: I/O J16-P4>8

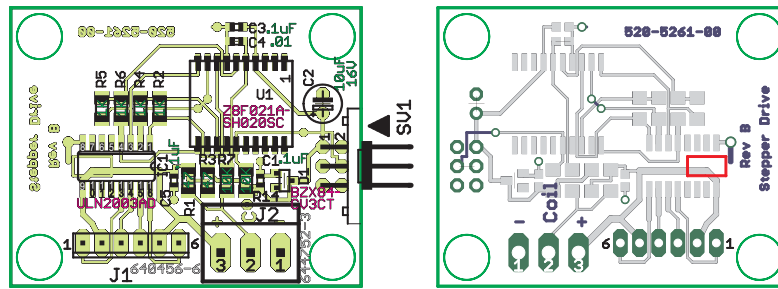

ITEM	QTY	PART NUMBER	REF-DESIGNATOR	DESCRIPTION (value, device)
A-B	1	511-5045-00	Stepper Motor Controller PCB Assembly (Item A PCB + Item B Spacers)	
A	1	520-5261-00	Stepper Motor Controller PCB	(includes Items A-1 - A-12)
A-1	1		SV1	929838-04-36, 3M Strip Conn.
A-2	1		C4	.01, Capacitor C-USC0603
A-3	3		C1, C3, C5	.1uF, Capacitor C-USC0603
A-4	4		R2, R4, R5, R6	1K Ω Resistor SMT, R-US_R1206
A-5	2		R7, R14 (not screened on PCB, see above for location)	10K Ω Resistor SMT, R-US_R1206
A-6	1	<i>If a part is required</i>	C2	10uF 16V, Capacitor CPOL-USE2.5-5
A-7	2	<i>where a part number</i>	R1, R3 (not screened on PCB, see above for location)	47 Ω Resistor SMT, R-US_R1206
A-8	1	<i>is not provided, call</i>	J1	6-Pin Conn., 640456-6, MTA06-100
A-9	1	<i>Technical Support</i>	J2	3-Pin Conn., 644752-3, MTA03-156
A-10	1	<i>(see back of cover).</i>	D1	Zener Diode, SOT-23 BZX84CV3CT
A-11	1		IC1	ULN2003AD Transistor
A-12	1		U1	Z8F021ASH020SC, ZiLOG XP (2KB Z8 Encore! XP® Flash MCU, 20 SOIC)
B	4	254-5007-02		Spacer, Sfl. Rtn. 1/4" White

Items A+ B secured to playfield bu #6 X 3/4" SHWH AB (Zinc) (Qty. 1/per) (234-5003-00)

Auxiliary (3X Transistor) Driver PCB (in Backbox) with the Coin/Ticket Meter and Ticket Dispenser Wiring Diagram

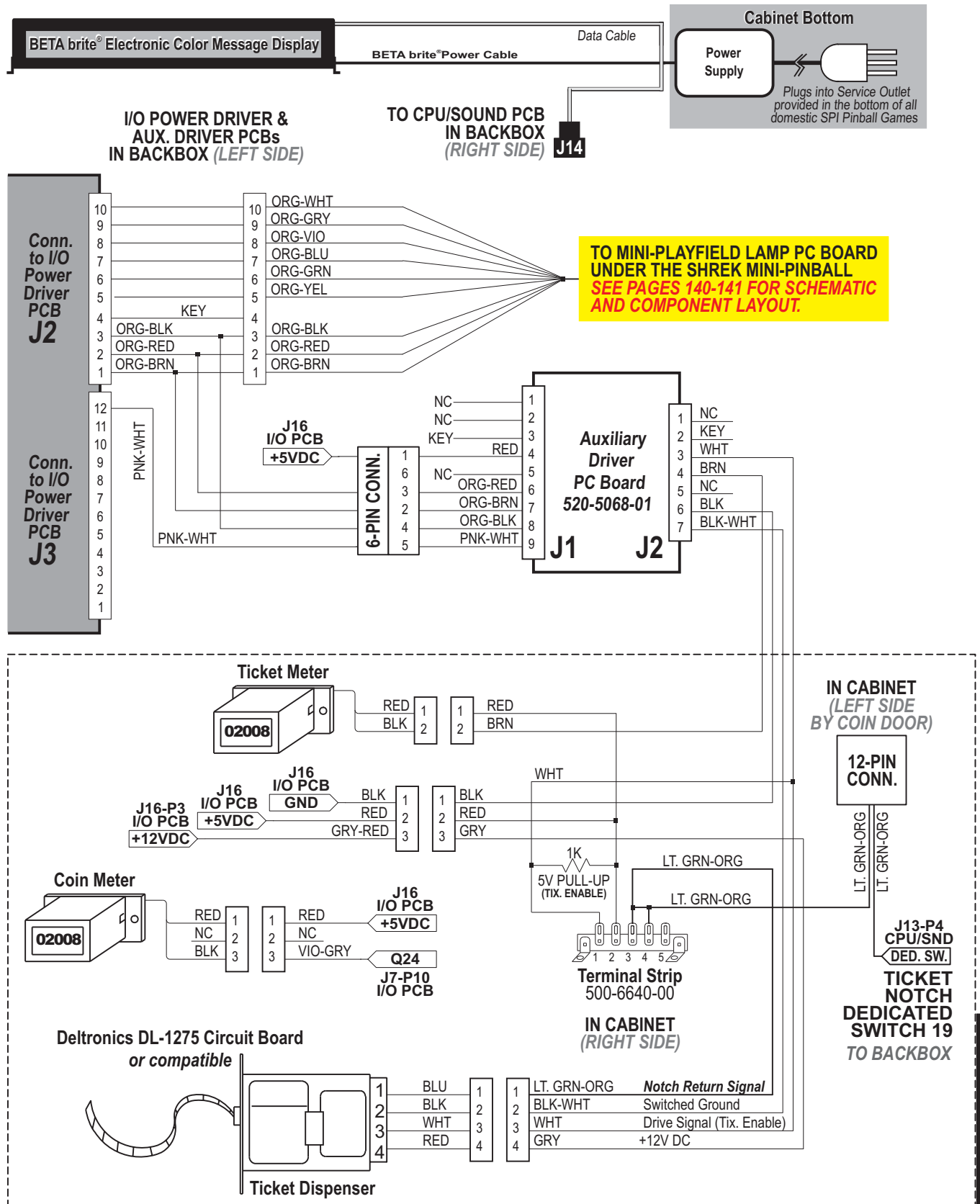

Sec. 5: PCBs

Auxiliary (3X Transistor) Driver PCB Schematic

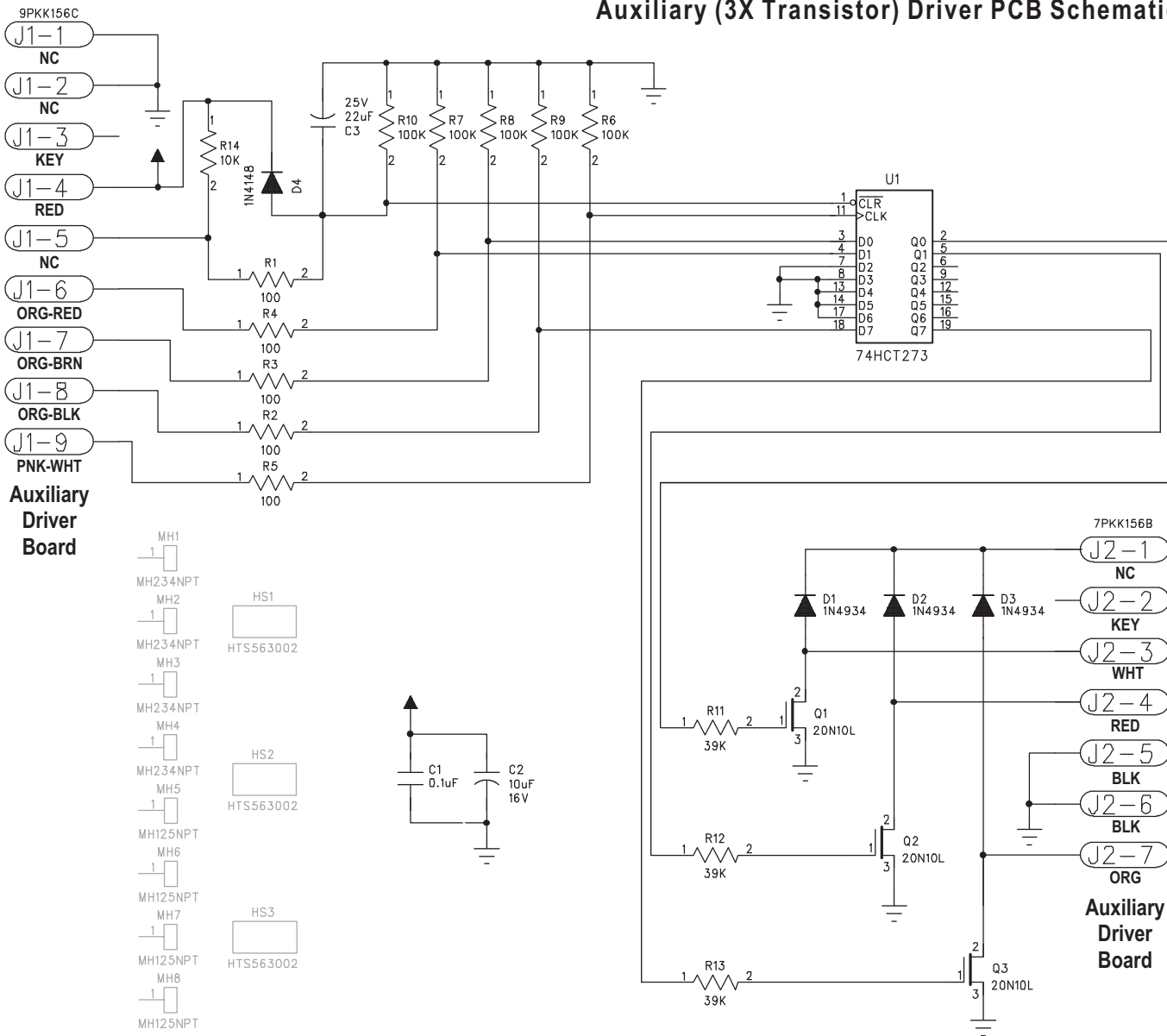

Auxiliary (3X Transistor) Driver PCB Component Layout

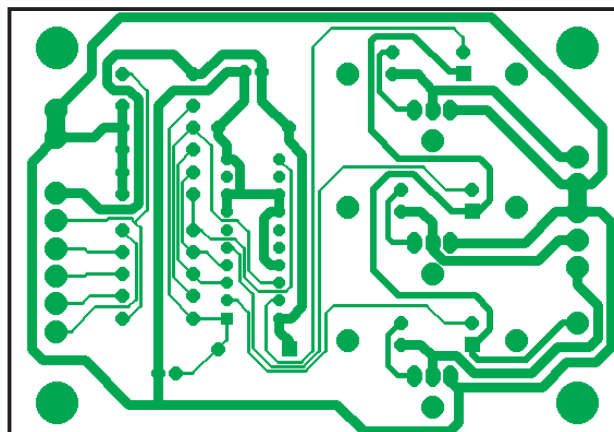
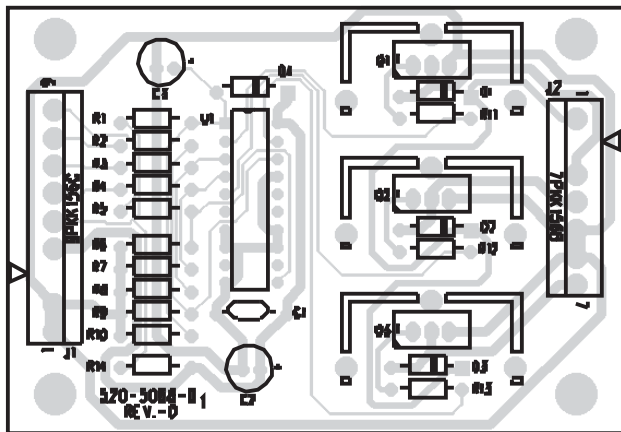

Sec. 5: PCBs

ITEM	QTY	PART NUMBER	REF-DESIGNATOR	DESCRIPTION
—	1	520-5068-01	Aux. / Solenoid Expander PCB (x3 Transistor)	Complete PCB Assembly



Appendixes A through J

Table of Contents for Appendixes

- ARCHIVE
 • **Appendix A : Pinball Game Firmware TableA1-A2**
 ▶ [White Star Board System and S.A.M. System Only*]
 ▷ ... describes the ROM / Chip Size / Program & Raw Part Number / USA Version / Check Sum and CPU/Sound PCB I & II ROM locations for Games Apollo 13 — Grand Prix (White Star Games); World Poker Tour – current (S.A.M. Games).
- **Appendix B : Semi-Conductors / I.C.'s / Relays Cross-Reference Table B1**
 ▷ ...describes diodes and transistors with Source Number, SPI Part Number, NTE Number, ECG Number, Radio Shack Number & RCA Part Number (*If applicable*).
- **Appendix C : Production Start Date, Manual Part N^o, ROM Size & Positions and Jumper W6 .. C1**
 ▶ [White Star Board System and S.A.M. System Only*]
 ▷ ...provides the Production Start Date, Manual Part Number, ROM Position(s), and Jumpers Installed for Games Apollo 13 — Grand Prix (White Star Games); World Poker Tour – current (S.A.M. Games).
- ARCHIVE
 • **Appendix D : Board TyPe Table D1-D2**
 ▶ [White Star Board System and S.A.M. System Only*]
 ▷ ...provides the Flipper**, I/O Power Driver, CPU/Sound, Display Power Supply, Dot Matrix Display, Display Controller, OPTOs and Misc. Board Part Numbers for Games Apollo 13 — Grand Prix (White Star Games); World Poker Tour – current (S.A.M. Games). ***Flipper Bd. with White Star Bd. System for A13 & Golden Eye only.*
- ARCHIVE
 • **Appendix E : Generic Coil Cross-Reference Guide & Flipper Coil TableE1-E2**
 ▶ [White Star Board System and S.A.M. System Only*]
 ▷ ...provides the Coils used with Part Number and Gauge-Turns (*of the coil*) for Games Apollo 13 — Grand Prix (White Star Games); World Poker Tour – current (S.A.M. Games).
- ARCHIVE
 • **Appendix F : Motor Specification Table F1-F2**
 ▶ [White Star Board System and S.A.M. System Only*]
 ▷ ...provides all the Motor Function, Specifications and Part Number for Games Apollo 13 — Grand Prix (White Star Games); World Poker Tour – current (S.A.M. Games)..
- **Appendix G : Part Number Prefix Classification Codes G1**
 ▷ ...explains how our Part Numbers are developed to help sort parts easier.
- **Appendix H : Playfield Inserts (Plastic Light Covers) H1**
 ▷ ...gives a pictoral view with the name and Part Nr. of all the inserts used (*with Color Code Chart*).
- **Appendix I : Stand-Up Targets & Modular Stand-Up Targets I1-I2**
 ▷ ...gives a pictoral view with the name and Part Number of all the Single Stand-Up Targets used (*with Color Code Chart*).
- **Appendix J : Coin Cards (USA & International) J1**
 ▷ ...gives a pictoral view with the name and Part Number of all the current Coin Cards for USA, Canada, Euro and other International Countries. *For all Coin Cards and/or free Coin Card files for download, visit our website : www.sternpinball.com*



APPENDIX A



Pinball Game Firmware (White Star Board System* Only) Table

See website for the latest International Code or Updated USA version / checksums

ROM	Chip Size	Program Part N ^o	USA ver. & Check Sum	Bd. Loc.	Raw Part N ^o
Apollo 13 (Note 1)					
Game ROM	(1M)	965-0208-00	A5.01 \$09FF	U210	960-5009-00
Sound	(512K)	965-0212-00	1.00 \$5244	U7	960-7001-02
Display	(4M)	965-0213-00	A5.00 \$B92B	ROM 0	960-5015-01
Voice 1	(4M)	965-0209-00	1.00 \$7FC7	U17	n/a (masked)
Voice 2	(4M)	965-0210-00	1.00 \$8E55	U21	n/a (masked)
Voice 3	(4M)	965-0211-00	1.00 \$08EE	U36	n/a (masked)
Golden Eye (Note 1)					
Game ROM	(1M)	965-0214-42	A4.04 \$3FFF	U210	960-5009-00
Sound	(512K)	965-0217-42	1.00 \$D615	U7	960-7001-02
Display	(4M)	965-0218-42	A4.00 \$E6ED	ROM 0	960-5015-01
Voice 1	(4M)	965-0215-42	1.00 \$3E32	U17	n/a (masked)
Voice 2	(4M)	965-0216-42	1.00 \$71F0	U21	n/a (masked)
Twister (Note 2)					
Game ROM	(1M)	965-0219-41	A4.05 \$E9FF	U210	960-5009-00
Sound	(512K)	965-0221-41	1.00 \$1FFF	U7	960-7001-02
Display	(4M)	965-0222-41	A4.00 \$FD01	ROM 0	960-5015-01
Voice 1	(4M)	965-0220-41	1.00 \$3650	U17	960-5015-01
Voice 2	(4M)	965-0223-41	1.00 \$9300	U21	960-5015-01
ID4: Independence Day (Note 2)					
Game ROM	(1M)	965-0224-45	A2.02 \$9CFF	U210	960-5009-00
Sound	(512K)	965-0227-45	1.00 \$222B	U7	960-7001-02
Display	(4M)	965-0228-45	A2.00 \$AB77	ROM 0	960-5015-01
Voice 1	(4M)	965-0225-45	1.00 \$3F41	U17	960-5015-01
Voice 2	(4M)	965-0226-45	1.00 \$206E	U21	960-5015-01
Space Jam (Note 2)					
Game ROM	(1M)	965-0229-43	A3.00 \$E6FF	U210	960-5009-00
Sound	(512K)	965-0233-43	1.00 \$F1E7	U7	960-7001-02
Display	(4M)	965-0230-43	A3.00 \$0057	ROM 0	960-5015-01
Voice 1	(4M)	965-0234-43	1.00 \$D8A8	U17	960-5015-01
Voice 2	(4M)	965-0231-43	1.00 \$DDF1	U21	960-5015-01
Voice 3	(4M)	965-0232-43	1.00 \$F32A	U36	960-5015-01
The Star Wars Trilogy - Special Edition (S.E.) (Note 2)					
Game ROM	(1M)	965-0235-56	A4.03 \$5EFF	U210	960-5009-00
Sound	(512K)	965-0238-56	1.00 \$4A7D	U7	960-7001-02
Display	(4M)	965-0239-56	A4.00 \$8817	ROM 0	960-5015-01
Voice 1	(4M)	965-0236-56	1.00 \$E66B	U17	960-5015-01
Voice 2	(4M)	965-0237-56	1.00 \$8F54	U21	960-5015-01
The Lost World: Jurassic Park (Note 2)					
Game ROM	(1M)	965-0240-53	A2.02 \$C8FF	U210	960-5009-00
Sound	(512K)	965-0243-53	1.00 \$A35B	U7	960-7001-02
Display	(4M)	965-0244-53	A2.01 \$7F46	ROM 0	960-5015-01
Voice 1	(4M)	965-0241-53	1.00 \$1D27	U17	960-5015-01
Voice 2	(4M)	965-0242-53	1.00 \$8DA4	U21	960-5015-01
The X-Files (Note 2)					
Game ROM	(1M)	965-0245-46	A3.03 \$A2FF	U210	960-5009-00
Sound	(512K)	965-0248-46	1.00 \$65A8	U7	960-7001-02
Display	(4M)	965-0249-46	A3.00 \$66D0	ROM 0	960-5015-01
Voice 1	(4M)	965-0246-46	1.00 \$349D	U17	960-5015-01
Voice 2	(4M)	965-0247-46	1.00 \$629C	U21	960-5015-01
Starship Troopers (Note 3)					
Game ROM	(1M)	965-0250-59	A2.00 \$85FF	U210	960-5009-00
Sound	(512K)	965-0253-59	1.00 \$64B2	U7	960-7001-02
Display	(4M)	965-0254-59	A2.00 \$E77B	ROM 0	960-5015-01
Voice 1	(4M)	965-0251-59	1.00 \$152A	U17	960-5015-01
Voice 2	(4M)	965-0252-59	1.00 \$0291	U21	960-5015-01
Voice 3	(4M)	965-0255-59	1.00 \$95A7	U36	960-5015-01
Viper Night Drivin' (Note 4)					
Game ROM	(1M)	965-0266-35	A2.01 \$C5FF	U210	960-5009-00
Sound	(512K)	965-0271-35	1.00 \$4DF8	U7	960-7001-02
Display	(4M)	965-0272-35	A2.01 \$C17D	ROM 0	960-5015-01
Voice 1	(4M)	965-0267-35	1.00 \$9018	U17	960-5015-01
Voice 2	(4M)	965-0268-35	1.00 \$2157	U21	960-5015-01
Voice 3	(4M)	965-0269-35	1.00 \$B5A6	U36	960-5015-01
Voice 4	(4M)	965-0270-35	1.00 \$D01E	U37	960-5015-01
Lost In Space (Note 4)					
Game ROM	(1M)	965-0282-60	A1.01 \$B2FF	U210	960-5009-00
Sound	(512K)	965-0287-60	1.00 \$A6AF	U7	960-7001-02
Display	(4M)	965-0288-60	A1.02 \$32AB	ROM 0	960-5015-01
Voice 1	(4M)	965-0283-60	1.00 \$4391	U17	960-5015-01
Voice 2	(4M)	965-0284-60	1.00 \$8215	U21	960-5015-01
Voice 3	(4M)	965-0285-60	1.00 \$5B32	U36	960-5015-01
Voice 4	(4M)	965-0286-60	1.00 \$8971	U37	960-5015-01
Godzilla (Note 4)					
Game ROM	(1M)	965-0289-40	A2.05 \$B1FF	U210	960-5009-00
Sound	(512K)	965-0294-40	1.00 \$0CC9	U7	960-7001-02
Display	(4M)	965-0290-40	A2.00 \$C929	ROM 0	960-5015-01
Voice 1	(4M)	965-0290-40	1.00 \$0D75	U17	960-5015-01
Voice 2	(4M)	965-0291-40	1.00 \$CCCF	U21	960-5015-01
Voice 3	(4M)	965-0292-40	1.00 \$227F	U36	960-5015-01
Voice 4	(4M)	965-0293-40	1.00 \$DB69	U37	960-5015-01
South Park (Notes 4, 5)					
Game ROM	(1M)	965-0301-71	A1.03 \$58FF	U210	960-5009-00
Sound	(512K)	965-0306-71	1.00 \$1286	U7	960-7001-02
Display	(4M)	965-0307-71	A1.01 \$166F	ROM 0	960-5015-01
Voice 1	(8M)	965-0302-71	1.00 \$7BF8	U17	960-5016-00
Voice 2	(8M)	965-0303-71	1.00 \$9CC0	U21	960-5016-00
Voice 3	(8M)	965-0304-71	1.00 \$ADD9	U36	960-5016-00
Voice 4	(8M)	965-0305-71	1.00 \$6559	U37	960-5016-00

ROM	Chip Size	Program Part N ^o	USA ver. & Check Sum	Bd. Loc.	Raw Part N ^o
Harley-Davidson® (Notes 4, 5, 6) Original (1999-2001)					
Game ROM	(1M)	965-0319-67	A1.03 \$3EFF	U210	960-5009-00
Sound	(512K)	965-0320-67	1.00 \$F4FF	U7	960-7001-02
Display	(4M)	965-0321-67	A1.04 \$FC7C	ROM 0	960-5015-01
Voice 1	(8M)	965-0322-67	1.00 \$CD26	U17	960-5016-00
Voice 2	(8M)	965-0323-67	1.00 \$3936	U21	960-5016-00
Voice 3	(8M)	965-0324-67	1.00 \$FB72	U36	960-5016-00
Voice 4	(4M)	965-0325-67	1.00 \$6100	U37	960-5015-01
► Harley-Davidson® (Notes 4, 5, 6, 8) 2nd Edition (2002-2003)					
Game ROM	(1M)	965-0319-67A	A1.08 \$23FF	U210	960-5009-00
Display	(4M)	965-0321-67A	A1.05 \$B594	ROM 0	960-5015-01
► Harley-Davidson® (Notes 4, 5, 6, 8) 3rd Edition (2004)					
Game ROM	(1M)	965-0319-87	A4.00 \$1CFF	U210	960-5009-00
Display	(4M)	965-0321-87	A4.00 \$F4FF	U5	960-5015-01
Striker Xtreme (Notes 4, 5)					
Game ROM	(1M)	965-0326-68	A1.03 \$E4FF	U210	960-5009-00
Sound	(512K)	965-0327-68	1.00 \$3BCA	U7	960-7001-02
Display	(4M)	965-0328-68	A1.03 \$1957	ROM 0	960-5015-01
Voice 1	(8M)	965-0329-68	1.00 \$482A	U17	960-5016-00
Voice 2	(8M)	965-0330-68	1.00 \$7312	U21	960-5016-00
Voice 3	(8M)	965-0331-68	1.00 \$DE2F	U36	960-5016-00
Voice 4	(8M)	965-0332-68	1.00 \$C508	U37	960-5016-00
NFL (Notes 4, 5) Not on CD-R or Website: Code through Distributor Only.					
Game ROM	(1M)	965-0339-73	A1.00 \$D2FF	U210	960-5009-00
Sound	(512K)	965-0340-73	1.00 U7	U7	960-7001-02
Display	(4M)	965-0341-73	A1.01 \$845A	ROM 0	960-5015-01
Voice 1	(8M)	965-0342-73	1.00 U17	U17	960-5016-00
Voice 2	(8M)	965-0343-73	1.00 U21	U21	960-5016-00
Voice 3	(8M)	965-0344-73	1.00 U36	U36	960-5016-00
Voice 4	(8M)	965-0345-73	1.00 U37	U37	960-5016-00
Sharkey's Shootout (Notes 4, 5)					
Game ROM	(1M)	965-0333-72	A2.11 \$49FF	U210	960-5009-00
Sound	(512K)	965-0333-72	1.01 \$9796	U7	960-7001-02
Display	(4M)	965-0335-72	A2.01 \$6C33	ROM 0	960-5015-01
Voice 1	(8M)	965-0336-72	1.00 \$58EA	U17	960-5016-00
Voice 2	(8M)	965-0337-72	1.00 \$272B	U21	960-5016-00
Voice 3	(8M)	965-0338-72	1.00 \$41AE	U36	960-5016-00
High Roller Casino (Notes 4, 5)					
Game ROM	(1M)	965-0346-65	A3.00 \$90FF	U210	960-5009-00
Sound	(512K)	965-0347-65	1.00 \$581C	U7	960-7001-02
Display	(4M)	965-0348-65	A3.00 \$74B3	ROM 0	960-5015-01
Voice 1	(8M)	965-0349-65	1.00 \$E12D	U17	960-5016-00
Voice 2	(8M)	965-0350-65	1.00 \$38F4	U21	960-5016-00
Voice 3	(8M)	965-0351-65	1.00 \$1B54	U36	960-5016-00
Voice 4	(8M)	965-0352-65	1.00 \$D720	U37	960-5016-00
Austin Powers™ (Notes 4, 5)					
Game ROM	(1M)	965-0353-74	A3.02 \$5DFF	U210	960-5009-00
Sound	(512K)	965-0354-74	1.00 \$D47B	U7	960-7001-02
Display	(4M)	965-0355-74	A3.00 \$6A3A	ROM 0	960-5015-01
Voice 1	(8M)	965-0356-74	1.00 \$D2B9	U17	960-5016-00
Voice 2	(8M)	965-0357-74	1.00 \$9E75	U21	960-5016-00
Voice 3	(8M)	965-0358-74	1.00 \$51F3	U36	960-5016-00
Voice 4	(8M)	965-0359-74	1.00 \$0AE5	U37	960-5016-00
MONOPOLY® (Notes 4, 5)					
Game ROM	(1M)	965-0360-75	A3.20 \$07FF	U210	960-5009-00
Sound	(512K)	965-0361-75	1.00 \$8C18	U7	960-7001-02
Display	(4M)	965-0362-75	A3.01 \$A381	ROM 0	960-5015-01
Voice 1	(8M)	965-0363-75	1.00 \$35E6	U17	960-5016-00
Voice 2	(8M)	965-0364-75	1.00 \$35A4	U21	960-5016-00
Voice 3	(8M)	965-0365-75	1.00 \$8A9F	U36	960-5016-00
Playboy (Notes 4, 5, 7)					
Game ROM	(1M)	965-0367-76	A5.00 \$7DFF	U210	960-5009-00
Sound	(512K)	965-0368-76	1.02 \$E7C2	U7	960-7001-02
Display	(4M)	965-0369-76	A5.00 \$A5FF	ROM 0	960-5015-01
Voice 1	(8M)	965-0370-76	1.00 \$9A9E	U17	960-5016-00
Voice 2	(8M)	965-0371-76	1.00 \$9F34	U21	960-5016-00
Voice 3	(8M)	965-0372-76	1.00 \$374B	U36	960-5016-00
Voice 4	(8M)	965-0373-76	1.00 \$237A	U37	960-5016-00
RollerCoaster Tycoon™ (Notes 4, 5, 7)					
Sound	(512K)	965-0374-78	1.00 \$F663	U7	960-7001-02
Game ROM	(1M)	965-0375-78	A7.02 \$5E5F	U210	960-5009-00
Voice 1	(8M)	965-0377-78	1.		



APPENDIX A

Pinball Game Firmware (White Star Board System* & S.A.M. System** Only) Table



See website for the latest International Code or Updated USA version / checksums

ROM	Chip Size	Program Part N°	USA Ver. & Check Sum	Bd. Loc.	Raw Part N°
Ripley's Believe It or Not!® (Notes 7, 8)					
Sound	(512K)	965-0408-81	1.00 \$D93D	U7	960-7001-02
Game ROM	(1M)	965-0409-81	A3.20 \$43FF	U210	960-5009-00
Voice 1	(8M)	965-0410-81	1.00	\$067B U17	960-5016-00
Voice 2	(8M)	965-0411-81	1.00	\$C8B8 U21	960-5016-00
Voice 3	(8M)	965-0412-81	1.00	\$6402 U36	960-5016-00
Voice 4	(8M)	965-0413-81	1.00	\$5341 U37	960-5016-00
Display	(4M)	965-0414-81	A3.00 \$DE4B	U5 DC PCB	960-5015-01

Elvis® (Notes 7, 8)					
Sound	(512K)	965-0415-84	1.00 \$8CD2	U7	960-7001-02
Game ROM	(1M)	965-0416-84	A5.00 \$50FF	U210	960-5009-00
Voice 1	(8M)	965-0417-84	1.00	\$538D U17	960-5016-00
Voice 2	(8M)	965-0418-84	1.00	\$8BCD U21	960-5016-00
Voice 3	(8M)	965-0419-84	1.00	\$60F8 U36	960-5016-00
Voice 4	(8M)	965-0420-84	1.00	\$14D8 U37	960-5016-00
Display	(4M)	965-0421-84	A5.00 \$A1F6	U5 DC PCB	960-5015-01

The SopranosSM (Notes 7, 8)					
Sound	(512K)	965-0422-85	4.00 \$9B5A	U7	960-7001-02
Game ROM	(1M)	965-0423-85	A5.00 \$5BFF	U210	960-5009-00
Voice 1	(8M)	965-0424-85	3.00	\$F01E U17	960-5016-00
Voice 2	(8M)	965-0425-85	1.04	\$C14C U21	960-5016-00
Voice 3	(8M)	965-0426-85	1.04	\$47A3 U36	960-5016-00
Voice 4	(8M)	965-0427-85	1.04	\$ADCD U37	960-5016-00
Display	(4M)	965-0428-85	A5.00 \$B4BB	U5 DC PCB	960-5015-01

NASCAR® (Notes 7, 8)					
Sound	(512K)	965-0429-86	2.00 \$32B3	U7	960-7001-02
Game ROM	(1M)	965-0430-86	A4.50 \$39FF	U210	960-5009-00
Voice 1	(8M)	965-0431-86	2.00	\$CFFB U17	960-5016-00
Voice 2	(8M)	965-0432-86	2.00	\$22C0 U21	960-5016-00
Voice 3	(8M)	965-0433-86	2.00	\$5FC8 U36	960-5016-00
Voice 4	(8M)	965-0434-86	2.00	\$2902 U37	960-5016-00
Display	(4M)	965-0435-86	A4.00 \$92BD	U5 DC PCB	960-5015-01

Grand Prix (Notes 7, 8)					
Sound	(512K)	965-0429-91	V1.00 \$6F89	U7	960-7001-02
Game ROM	(1M)	965-0430-91	A4.50 \$5EFF	U210	960-5009-00
Voice 1	(8M)	965-0431-91	1.00	\$C0E5 U17	960-5016-00
Voice 2	(8M)	965-0432-91	1.00	\$F406 U21	960-5016-00
Voice 3	(8M)	965-0433-91	1.00	\$057D U36	960-5016-00
Voice 4	(8M)	965-0434-91	1.00	\$2646 U37	960-5016-00
Display	(4M)	965-0435-91	A4.00 \$DA8E	U5 DC PCB	960-5015-01

[NDSE] (Notes 7, 8) <i>Call for more info if code update required.</i>					
Sound	(512K)	965-0436-97		U7	960-7001-02
Game ROM	(1M)	965-0437-97		U210	960-5009-00
Voice 1	(8M)	965-0438-97		U17	960-5016-00
Voice 2	(8M)	965-0439-97		U21	960-5016-00
Voice 3	(8M)	965-0440-97		U36	960-5016-00
Voice 4	(8M)	965-0441-97		U37	960-5016-00
Display	(4M)	965-0442-97		U5 DC PCB	960-5015-01

**** GAMES BELOW THIS LINE / NEXT COLUMN ARE S.A.M. SYSTEM GAMES**

TO ORDER MEMORY STICK WITH GAME FILES FROM YOUR DISTRIBUTOR, USE SPI PART NUMBER 970-0128-00 & INCLUDE THE GAME NAME / LANGUAGE FILE(S) DESIRED.

World Poker Tour™ Pinball (WPT) (Notes 7, 9)					
Boot B-02	(8M)	965-BOOT-SAM	1.04 \$7E62	U9	960-5016-00 unprogrammed
Memory Stick 128MB (970-0128-00)		Version		System	Bin Files:
English + Spanish		1.12AL		1.17+	WPT0112AL.bin
English Only		1.12A		1.17+	WPT0112A.bin
English + French		1.12AF		1.17+	WPT0112AF.bin
French Only		1.12F		1.17+	WPT0112F.bin
German + French		1.12GF		1.17+	WPT0112GF.bin
German Only		1.12G		1.17+	WPT0112G.bin
English + Italian		1.12AI		1.17+	WPT0112AI.bin
Italian Only		1.12I		1.17+	WPT0112I.bin

NOTE: THE TYPICAL SIZE PER UNZIPPED BIN FILE IS 25MB – 30MB+/-

The Simpsons™ Kooky Carnival Redemption (Note 9)					
Boot B-02	(8M)	965-BOOT-SAM	1.04 \$7E62	U9	960-5016-00 unprogrammed
Memory Stick 128MB (970-0128-00)		Version		Bin Files:	
English Only		1.05		SKC0105.bin	
English New Jersey Only		0.09NJ		SKC0090NJ.bin	

NOTE: THE TYPICAL SIZE PER UNZIPPED BIN FILE IS 5.5MB +/-

©Disney's Pirates of the Caribbean Pinball (POTC) (Notes 7, 9)					
Boot B-02	(8M)	965-BOOT-SAM	1.06 \$2014	U9	960-5016-00 unprogrammed
Memory Stick 128MB (970-0128-00)		Version		System	Bin Files:
English + Spanish		1.15AS		1.17+	POTC115AS.bin
English + French		1.15AF		1.17+	POTC115AF.bin
German + French		1.15GF		1.17+	POTC115GF.bin
English + Italian		1.15AI		1.17+	POTC115AI.bin

NOTE: THE TYPICAL SIZE PER UNZIPPED BIN FILE IS 25MB – 30MB+/-

Family Guy™ Pinball (FG) (Notes 7, 9)					
Boot B-02	(8M)	965-BOOT-SAM	2.09 \$10A3	U9	960-5016-00 unprogrammed
Memory Stick 128MB (970-0128-00)		Version		System	Bin Files:
English + Spanish		10.00AL		1.23+	FG1000AL.bin
English + French		10.00AF		1.23+	FG1000AF.bin
English + German		10.00AG		1.23+	FG1000GF.bin
English + Italian		10.00AI		1.23+	FG1000AI.bin

NOTE: THE TYPICAL SIZE PER UNZIPPED BIN FILE IS 25MB – 30MB+/-

Spider-Man™ Pinball (S-M) (Notes 7, 9)					
Boot B-02	(8M)	965-BOOT-SAM	2.10 \$F625	U9	960-5016-00 unprogrammed
Memory Stick 128MB (970-0128-00)		Version		System	Bin Files:
English + Spanish		1.3ES		1.27+	spd_1_30_es.bin
English + French		1.3EF		1.27+	spd_1_30_ef.bin
German + French		1.3GF		1.27+	spd_1_30_gf.bin
English + Italian		1.3EI		1.27+	spd_1_30_ei.bin

NOTE: THE TYPICAL SIZE PER UNZIPPED BIN FILE IS 25MB – 30MB+/-

footnotes:

- 1 ROMs on CPU/Sound Bd.: 520-5136-00 (Stereo) & Display Cont. Bd.: 520-5055-01
- 2 ROMs on CPU/Sound Bd.: 520-5136-10 (Mono) & Display Cont. Bd.: 520-5055-01
- 3 ROMs on CPU/Sound Board: 520-5136-15* (Mono) (*FCC 11-97) & Display Controller Board: 520-5055-02* (*FCC 11-97)



APPENDIX A

Pinball Game Firmware Table

EPROM	Chip Size	Program Part N ^o	USA Ver.	Bd. Loc.	Raw Part N ^o	EPROM	Chip Size	Program Part N ^o	USA Ver.	Bd. Loc.	Raw Part N ^o
Laser War						Lethal Weapon 3					
CPU	(256K)	965-0004-00	LWAR.C5	C5	960-5007-00	CPU	(512K)	965-0082-00	A2.08	C5	960-7001-02
Sound (Old)	(256K)	965-0005-00		J5	960-5007-00	Voice 1	(2M)	965-0083-00		U17	960-5010-00
Sound (Old)	(256K)	965-0006-00		J6	960-5007-00	Voice 2	(2M)	965-0084-00		U21	960-5010-00
Sound (Old)	(256K)	965-0007-00		J7	960-5007-00	Sound	(256K)	965-0085-00		U7	960-5007-00
			- OR -			Display	(2M)	965-0086-00	A2.06	ROM 0	960-5010-00
Sound	(256K)	965-0008-00		7F	960-5007-00	Display	(2M)	965-0087-00	A2.06	ROM 1	960-5010-00
Sound 1	(512K)	965-0009-00		6F	960-7001-02						
Sound 2	(512K)	965-0010-00		4F	960-7001-02	Display	(4M)	965-0087-04	-OR- A2.06	ROM 0	960-5015-00
									(Used on Display PCB 520-5055-01)		
Secret Service						Star Wars					
CPU	(256K)	965-0011-00	A4-6	B5	960-5007-00	CPU	(512K)	965-0119-00	A1.03	C5	960-7001-02
CPU	(256K)	965-0012-00	A4-6	C5	960-5007-00	Voice 0	(4M)	965-0132-00		U17	960-5015-00
Voice 1	(512K)	965-0014-00		6F	960-7001-02	Voice 1	(2M)	965-0133-00		U21	960-5010-00
Voice 2	(512K)	965-0015-00		4F	960-7001-02	Sound	(256K)	965-0134-00		U7	960-5007-00
Sound	(256K)	965-0013-00		7F	960-5007-00	Display	(2M)	965-0120-00	A1.04	ROM 0	960-5010-00
						Display	(2M)	965-0121-00	A1.04	ROM 1	960-5010-00
									(Used on Display PCB 520-5055-00)		
						Display	(4M)	965-0122-00	-OR- A1.05	ROM 0	960-5015-00
									(Used on Display PCB 520-5055-01)		
Torpedo Alley						Rocky & Bullwinkle & Friends					
CPU	(256K)	965-0016-00	A2-1	B5	960-5007-00	CPU	(512K)	965-0138-00	A1.30	C5	960-7001-02
CPU	(256K)	965-0017-00	A2-1	C5	960-5007-00	Voice 0	(4M)	965-0139-00		U17	960-5015-00
Voice 1	(512K)	965-0019-00		6F	960-7001-02	Voice 1	(2M)	965-0140-00		U21	960-5010-00
Voice 2	(512K)	965-0020-00		4F	960-7001-02	Sound	(256K)	965-0141-00		U7	960-5007-00
Sound	(256K)	965-0018-00		7F	960-5007-00	Display	(4M)	965-0142-00	A1.30	ROM 0	960-5015-00
Time Machine						Jurassic Park					
CPU	(128K)	965-0021-00	A2-4	B5	960-5006-00	CPU	(512K)	965-0143-00	A5.13	C5	960-7001-02
CPU	(256K)	965-0022-00	A2-4	C5	960-5007-00	Voice 0	(4M)	965-0144-00		U17	960-5015-00
Voice 1	(512K)	965-0024-00		6F	960-7001-02	Voice 1	(2M)	965-0145-00		U21	960-5010-00
Voice 2	(512K)	965-0025-00		4F	960-7001-02	Sound	(256K)	965-0146-00		U7	960-5007-00
Sound	(256K)	965-0023-00		7F	960-5007-00	Display	(4M)	965-0147-00	A5.10	ROM 0	960-5015-00
Playboy 35th Anniversary						Last Action Hero					
CPU	(256K)	965-0046-00	A2-4	B5	960-5007-00	CPU	(512K)	965-0148-00	A1.12	C5	960-7001-02
CPU	(256K)	965-0047-00	A2-4	C5	960-5007-00	Voice 0	(4M)	965-0149-00		U17	960-5015-00
Voice 1	(512K)	965-0049-00		6F	960-7001-02	Voice 1	(2M)	965-0150-00		U21	960-5010-00
Voice 2	(512K)	965-0050-00		4F	960-7001-02	Sound	(256K)	965-0151-00		U7	960-5007-00
Sound	(256K)	965-0048-00		7F	960-5007-00	Display	(4M)	965-0152-00	A1.06	ROM 0	960-5015-00
ABC Monday Night Football						Tales from the Crypt					
CPU	(128K)	965-0031-00	A2-7	B5	960-5006-00	CPU	(512K)	965-0157-00	A3.03	C5	960-7001-02
CPU	(256K)	965-0032-00	A2-7	C5	960-5007-00	Voice 0	(4M)	965-0158-00		U17	960-5015-00
Voice 1	(512K)	965-0034-00		6F	960-7001-02	Voice 1	(2M)	965-0159-00		U21	960-5010-00
Voice 2	(512K)	965-0035-00		4F	960-7001-02	Sound	(256K)	965-0160-00		U7	960-5007-00
Sound	(256K)	965-0033-00		7F	960-5007-00	Display	(4M)	965-0161-00	A3.01	ROM 0	960-5015-00
Robocop						The Who's Tommy					
CPU	(256K)	965-0036-00	A3-4	B5	960-5007-00	CPU	(512K)	965-0162-00	A4.00	C5	960-7001-02
CPU	(256K)	965-0037-00	A3-4	C5	960-5007-00	Voice 1	(4M)	965-0163-00		U17	960-5015-00
Voice 1	(512K)	965-0040-00		6F	960-7001-02	Voice 2	(4M)	965-0166-00		U21	960-5010-00
Voice 2	(512K)	965-0040-00		4F	960-7001-02	Voice 3	(4M)	965-0167-00		U36	960-5015-00
Sound	(256K)	965-0038-00		7F	960-5007-00	Voice 4	(4M)	965-0168-00		U37	960-5015-00
						Sound	(512K)	965-0164-00		U7	960-7001-02
						Display	(4M)	965-0163-00	A4.00	ROM 0	960-5015-00
Phantom of the Opera						WWF Royal Rumble					
CPU	(128K)	965-0026-00	A3-2	B5	960-5006-00	CPU	(512K)	965-0169-00	A1.06	C5	960-7001-02
CPU	(256K)	965-0027-00	A3-2	C5	960-5007-00	Voice 1	(4M)	965-0172-00		U17	960-5015-00
Voice 1	(512K)	965-0029-00		6F	960-7001-02	Voice 2	(4M)	965-0173-00		U21	960-5010-00
Voice 2	(512K)	965-0030-00		4F	960-7001-02	Voice 3	(4M)	965-0174-00		U36	960-5015-00
Sound	(256K)	965-0028-00		7F	960-5007-00	Sound	(512K)	965-0171-00		U7	960-7001-02
						Display	(4M)	965-0170-00	A1.02	ROM 0	960-5015-00
Back to the Future						Guns N' Roses					
CPU	(256K)	965-0041-00	A2-0	B5	960-5007-00	CPU	(512K)	965-0175-00	A3.00	C5	960-7001-02
CPU	(256K)	965-0042-00	A2-0	C5	960-5007-00	Voice 1	(4M)	965-0178-00		U17	960-5015-00
Voice 1	(512K)	965-0044-00		6F	960-7001-02	Voice 2	(4M)	965-0179-00		U21	960-5010-00
Voice 2	(512K)	965-0045-00		4F	960-7001-02	Voice 3	(4M)	965-0180-00		U36	960-5015-00
Sound	(256K)	965-0043-00		7F	960-5007-00	Voice 4	(4M)	965-0181-00		U37	960-5015-00
						Sound	(512K)	965-0177-00		U7	960-7001-02
						Display	(4M)	965-0176-00	A3.00	ROM 0	960-5015-00
The Simpsons						Maverick *					
CPU	(128K)	965-0051-00	A2-7	B5	960-5006-00	CPU	(512K)	965-0182-00	A4.04	C5	960-7001-02
CPU	(256K)	965-0052-00	A2-7	C5	960-5007-00	Voice 1	(4M)	965-0186-00		U17	960-5015-00
Voice 1	(512K)	965-0054-00		6F	960-7001-02	Voice 2	(4M)	965-0187-00		U21	960-5010-00
Voice 2	(512K)	965-0055-00		4F	960-7001-02	Voice 3	(4M)	965-0187-01		U36	960-5015-00
Sound	(256K)	965-0053-00		7F	960-5007-00	Sound	(512K)	965-0185-00		U7	960-7001-02
						Display*	(4M)	965-0183-00	A4.01	ROM 0	960-5015-00
						Display*	(4M)	965-0184-00	A4.01	ROM 3	960-5015-00
Checkpoint						Mary Shelley's Frankenstein *					
CPU	(128K)	965-0056-00	A1-7	B5	960-5006-00	CPU	(512K)	965-0188-00	A1.03	C5	960-7001-02
CPU	(256K)	965-0134-00	A1-7	C5	960-5007-00	Voice 1	(4M)	965-0192-00		U17	960-5015-00
Voice 1	(1M)	965-0057-00		F7	960-5009-00	Voice 2	(4M)	965-0193-00		U21	960-5010-00
Voice 2	(1M)	965-0058-00		F5	960-5009-00	Voice 3	(4M)	965-0194-00		U36	960-5015-00
Sound	(256K)	965-0059-00		F4	960-5007-00	Sound	(512K)	965-0191-00		U7	960-7001-02
Display	(512K)	965-0060-00	CP80	U8	960-7001-02	Display*	(4M)	965-0189-00	A1.03	ROM 0	960-5015-00
						Display*	(4M)	965-0190-00	A1.03	ROM 3	960-5015-00
Teenage Mutant Ninja Turtles						Baywatch * (CPU Board 520-5003-04)					
CPU	(128K)	965-0061-00	A1.04	B5	960-5006-00	CPU	(512K)	965-0195-00	A4.00	C5	960-7001-02
CPU	(256K)	965-0062-00	A1.04	C5	960-5007-00	Voice 1	(4M)	965-0196-00		U17	960-5015-00
Voice 1	(1M)	965-0063-00		F5/6	960-5009-00	Voice 2	(4M)	965-0197-00		U21	960-5010-00
Voice 2	(1M)	965-0064-00		F4/5	960-5009-00	Sound	(512K)	965-0199-00		U7	960-7001-02
Sound	(256K)	965-0065-00		F7	960-5007-00	Display*	(4M)	965-0200-00	A4.00	ROM 0	960-5015-00
Display	(512K)	965-0066-00	A1.04	U8	960-7001-02	Display*	(4M)	965-0201-00	A4.00	ROM 3	960-5015-00
Batman						Batman Forever * (CPU Board 520-5003-04)					
CPU	(128K)	965-0067-00	A1.06	B5	960-5006-00	CPU	(512K)	965-0202-00	A3.02	C5	960-7001-02
CPU	(256K)	965-0135-00	A1.06	C5	960-5007-00	Voice 1	(4M)	965-0203-00		U17	960-5015-00
Voice 1	(2M)	965-0068-00		U17	960-5010-00	Voice 2	(4M)	965-0204-00		U21	960-5010-00
Voice 2	(2M)	965-0069-00		U21	960-5010-00	Sound	(512K)	965-0205-00		U7	960-7001-02
Sound	(256K)	965-0070-00		U7	960-5007-00	Display*	(4M)	965-0206-00			

APPENDIX B

Semi-Conductors / Integrated Circuits (I.C.) / Relays Cross-Reference Table

Table No	Type	Source Number	STERN® PINBALL	N T E®	E C G®	Radio Shack®	R C A®
RECTIFICATION, BLOCKING, DAMPENING DIODES AND/OR LIGHT EMITTING DIODES (LEDs)							
1	Diode	1N4001	112-5001-00	NTE552	ECG552	- - - - -	SK9000
	Diode	1N4004	112-5003-00	NTE116	ECG116	276-1103	SK3312
	Diode	1N5401	112-0056-00	NTE5801	ECG5801	276-1143	SK9004
	Diode	1N5404	112-5004-00	NTE5804	ECG5804	276-1144	SK9007
	Diode	T6A10L	112-5006-01	NTE5812	ECG5812	- - - - -	- - - - -
	Diode	FR302	112-5009-00	NTE588	ECG588	- - - - -	SK5014
	Diode, Signal	1N914	112-5014-00	- - - - -	- - - - -	- - - - -	- - - - -
LED	MT5000UR or TLRH180P (T1-3/4 GaAlAs)	165-5052-00 <i>(old SPI Part No: 165-5100-00)</i>	- - - - -	- - - - -	276-066B	- - - - -	
ZENER DIODES							
2	Diode	1N4742A 12v	112-0061-00	NTE142A	ECG142A	276-563	SK12V
	Diode	1N4760B 68v	112-0062-00B	NTE5092A	ECG5092A	- - - - -	SK68V
	Diode	1N4764A 100v	112-0049-00A	NTE5096A	ECG5096A	- - - - -	SK100V
	Diode	1N5228 3.9v	112-0053-00	NTE5007A	ECG5007A	- - - - -	SK3A9
	Diode	1N5234B 6.2v	112-0047-00B	NTE5013A	ECG5013A	276-561	SK6A2
	Diode	1N5379 110v	112-0072-00	NTE5157	ECG5157	- - - - -	SK110X
	Diode	1N6267A 6.8v	112-5011-00	NTE4902	ECG4902	- - - - -	- - - - -
	Diode	1N4752A 33v	112-5010-00A	NTE147A	ECG147A	- - - - -	SK33V
Diode	1N4736 6.8v 1w	112-5007-00	NTE5071A	ECG5071A	- - - - -	- - - - -	
TRANSISTORS - TYPE FET, NPN, PNP AND/OR SCR							
3	FET Trans.	STP20N10L	110-0106-00	NTE2987	ECG2987	- - - - -	- - - - -
	FET Trans.	STP19N06L	110-0088-00	NTE2985	ECG2985	- - - - -	- - - - -
	FET Trans.	VN02N	110-0089-00	- - - - -	- - - - -	- - - - -	- - - - -
	NPN Trans.	2N4401	110-0073-00	NTE85	ECG85	276-2009	SK3124A
	NPN Trans.	2N6427	110-0070-00	NTE48	ECG48	- - - - -	SK4906
	NPN Trans.	MJE340	110-0071-00	NTE157	ECG157	- - - - -	SK3747
	NPN Trans.	MPSA42	110-0082-00	NTE287	ECG287	- - - - -	SK3232
	NPN Trans.	2N3904	110-0069-00	NTE123AP	ECG123AP	276-2009	- - - - -
	NPN Trans.	TIP122	110-0067-00	NTE261	ECG261	276-2068	SK3896
	NPN Trans.	MJE15030	110-0101-00	NTE375	ECG375	- - - - -	SK9118
	PNP Trans.	2N5401	110-0078-00	NTE288	ECG288	- - - - -	SK3434
	PNP Trans.	MJE15031	110-0103-00	NTE292	ECG292	- - - - -	SK3441
	PNP Trans.	MJE350	110-0072-00	NTE374	ECG374	- - - - -	SK9042
	PNP Trans.	MPSA92	110-0100-00	NTE288	ECG278	- - - - -	SK3434
	PNP Trans.	TIP42	110-0068-00	NTE332	ECG332	- - - - -	SK9236
	PNP Trans.	TIP32C	110-0081-00	NTE292	ECG292	- - - - -	SK3441
	PNP Trans.	TIP36C	110-0077-00	NTE393	ECG393	- - - - -	SK3961
	SCR Trans.	2N5060	110-0074-00	NTE5400	ECG5400	276-1067	SK3950
SCR Trans.	SCR2800B	110-0083-00	NTE5461-8	ECG5461-8	- - - - -	- - - - -	
BRIDGE RECTIFIERS (BR)				Comments:			
4	BR (Present)	DB3501 or CM3501	112-5000-00	For White Star I/O Bds., BR = 35 Amp @ 100v P.I.V.			
RELAYS				Comments:			
5	Relay	FRL-264 D024/02CK	190-5002-00	For PPB, Power Supply, & White Star I/O Boards, Relay = 24v DC 10 Amp DPDT			
	Relay	FRL-264 D006/04CV	190-5001-00	For CPU Boards, Relay = 6v DC 5 Amp 4 Pole DT			





APPENDIX C

Production Start Date, Manual Part No., ROM Size & Positions and Jumper W6 Installed Note‡ (White Star Board System & S.A.M. System Only*)



Game Name White Star Bd. System™	Production Start Date and Manual Part Nr.	CPU/Sound Board Sound U7 512K CPU/Sound Board Game U210 1MB CPU/Sound Board Voice ROMS:				Jumper Installed (‡ see Note)	
		U17	U21	U36	U37		
* Note: For complete Appendix Information for Games <i>Laser War</i> through <i>Batman Forever</i> , see any Service Game Manual between <i>Apollo 13</i> through <i>Ripley's Believe It or Not!</i> or on-line at our website www.sternpinball.com/parts.htm ; also available on CD-R, 970-2003-00 (<i>The Simpsons™ Pinball Party</i> , <i>T3®</i> and <i>The Lord of the Rings™</i>).							
29	Apollo 13 (A13)	NOV 95 780-5044-00	4MB	4MB	4MB	Not Used	n / a
30	Golden Eye	FEB 96 780-5042-00	4MB	4MB	Not Used	Not Used	n / a
31	Twister	APR 96 780-5041-00	4MB	4MB	Not Used	Not Used	n / a
32	ID4: Independence Day	JUL 96 780-5045-00	4MB	4MB	Not Used	Not Used	n / a
33	Space Jam	OCT 96 780-5043-00	4MB	4MB	4MB	Not Used	n / a
34	The Star Wars Trilogy - Sp. Ed.	FEB 97 780-5056-00	4MB	4MB	Not Used	Not Used	n / a
35	The Lost World: Jurassic Park	JUN 97 780-5053-00	4MB	4MB	Not Used	Not Used	n / a
36	The X-Files	AUG 97 780-5046-00	4MB	4MB	Not Used	Not Used	n / a
37	Starship Troopers	NOV 97 780-5059-00	4MB	4MB	4MB	Not Used	n / a
38	Viper Night Drivin'	FEB 98 780-5035-00	4MB	4MB	4MB	4MB	n / a
39	Lost In Space	JUN 98 780-5060-00	4MB	4MB	4MB	4MB	n / a
40	Godzilla	SEP 98 780-5040-00	4MB	4MB	4MB	4MB	n / a
41	South Park	JAN 99 780-5071-00	8MB	8MB	8MB	8MB	W6
42a	Harley-Davidson®	AUG 99 780-5067-01	8MB	8MB	8MB	8MB	W6
42b	Harley-Davidson® 2nd Ed.	SEP 02 780-5067-10	8MB	8MB	8MB	8MB	W6
42c	Harley-Davidson® 3rd Ed.	OCT 04 780-5087-00	8MB	8MB	8MB	8MB	W6
43a	Striker Xtreme	MAR 00 780-5068-01	8MB	8MB	8MB	8MB	W6
43b	NFL	OCT 00 780-5073-00	8MB	8MB	8MB	8MB	W6
44	Sharkey's Shootout	JUL/OCT 00 780-5072-01	8MB	8MB	8MB	Not Used	W6
45	High Roller Casino	JAN 01 780-5065-00	8MB	8MB	8MB	8MB	W6
46	Austin Powers™	MAY 01 780-5074-00	8MB	8MB	8MB	8MB	W6
47	MONOPOLY®	SEP 01 780-5075-00	8MB	8MB	8MB	Not Used	W6
48	Playboy	FEB 02 780-5076-00	8MB	8MB	8MB	8MB	W6
49	RollerCoaster Tycoon™	AUG 02 780-5078-00	8MB	8MB	8MB	Not Used	W6
50	The Simpsons™ Pinball Party	JAN 03 780-5077-00	8MB	8MB	8MB	8MB	W6
51	T3®: Rise of the Machines™	MAY 03 780-5079-00	8MB	8MB	8MB	8MB	W6
52	The Lord of the Rings™	NOV 03 780-5080-00	8MB	8MB	8MB	8MB	
53	Ripley's Believe It or Not!®	APR 04 780-5081-00	8MB	8MB	8MB	8MB	

‡ Additional Information for **Installed Jumper** (above games 41-51):

• Installed **W6** so 8MB ROMS can be utilized. See the **CPU/Sound Board Schematic** (Sheet 2 of 3, Address Location 3E) in the games' Service Game Manual. Games 52 - 57 CPU/Sound Board differ than <51 (See Appendix D).

See **Apdx. A** for more detailed information on **Pinball Game Firmware** (ROM Name, Size, Part Numbers, USA Version & Checksum and Board Locations).

Game Name White Star Board System™	Production Start Date and Manual Part Nr.	CPU/Sound Board Sound U7 512K CPU/Sound Board Game U210 1MB CPU/Sound Board Voice ROMS:				
		U17	U21	U36	U37	
54	Elvis®	AUG 04 780-5084-00	8MB	8MB	8MB	8MB
55	The Sopranos™	FEB 05 780-5085-00	8MB	8MB	8MB	8MB
56	NASCAR®	JUL 05 780-5086-00	8MB	8MB	8MB	8MB
57	Grand Prix	SEP 05 780-5091-00	8MB	8MB	8MB	8MB

See **Apdx. A** for more detailed information on **Pinball Game Firmware** (ROM Name, Size, Part Numbers, USA Version & Checksum and Board Locations).

Game Name S.A.M. System	Production Start Date and Manual Part Nr.	S.A.M. System CPU/Sound Board Boot EPROM U9			
		965-BOOT-SAM (Programmed)			
58	World Poker Tour™ (WPT)	JUN 06 780-5088-00	8MB	B-02 V2.1+ chksum \$F625	LOC: U9
59	The Simpsons™ Kooky Carnival	APR 06 780-5090-00	8MB	B-02 V2.1+ chksum \$F625	LOC: U9
60	©Disney's Pirates of the Caribbean	AUG 06 780-5092-00	8MB	B-02 V2.1+ chksum \$F625	LOC: U9
61	Famil Guy™	DEC 06 780-5093-00	8MB	B-02 V2.1+ chksum \$F625	LOC: U9
62	Spider-Man™	MAY 07 780-5094-00	8MB	B-02 V2.1+ chksum \$F625	LOC: U9

Games 58 – current, S.A.M. System : CPU/Sound & I/O Power Driver PCBs differ than White Star (previous Games 29 – 57); Disp. Controller Not Required.





APPENDIX D

Board Type (White Star Board System* Only) Table



Game Name	Flipper	I/O Power Driver	CPU/Sound Stereo	Disp. Power Supply	Dot Matrix Display	Display Controller	OPTO Transmitter	OPTO Receiver	OPTO Application
Apollo 13	520-5080-00 2-Flipper	520-5137-00	520-5136-00	520-5138-00	520-5052-00 128 X 32 Dots	520-5055-01	520-5124-00 Single OPTO	520-5125-00 Single OPTO	5-Ball Trough over Up-Kicker
	Miscellaneous PC Boards:	Light Boards 520-5130-01, -04 & -05 Magnet Interface, 7-Segment Display & Light Bd. 520-5130-06 Magnet Driver Board 520-5130-02 Switch Membrane Board 520-5130-03				Relay Board 520-5010-00			
Golden Eye	520-5080-00 2-Flipper	520-5137-00	520-5136-00	520-5138-00	520-5052-00 128 X 32 Dots	520-5055-01	520-5124-00 Single OPTO	520-5125-00 Single OPTO	5-Ball Trough over Up-Kicker
	Miscellaneous PC Boards:	Light Boards 520-5128-05 through -08		Mag. Processor X2 Driver Bd. 520-5143-00	Relay Board 520-5010-00				
GAMES HEREON NO LONGER REQUIRE THE FLIPPER BOARD WITH THE WHITE STAR BOARD SYSTEM™									
Game Name	I/O Power Driver	CPU/Sound Mono	Disp. Power Supply	Dot Matrix Display	Display Controller	OPTO Transmitter	OPTO Receiver	OPTO Application	Misc OPTO & App.
Twister	520-5137-01	520-5136-10	520-5138-00	520-5052-00 128 X 32 Dots	520-5055-01	520-5124-00 Single OPTO	520-5125-00 Single OPTO	5-Ball Trough over Up-Kicker	
	Miscellaneous PC Boards:	Light Boards 520-5145-01 through -07		Mag. Drv. Bd. 520-5143-00	Relay Board 520-5010-00				
Independence Day (ID4)	520-5137-01	520-5136-10	520-5138-00	520-5052-00 128 X 32 Dots	520-5055-01	520-5124-00 Single OPTO	520-5125-00 Single OPTO	4-Ball Trough over Up-Kicker	
	Miscellaneous PC Boards:	Light Boards 520-5149-01 through -10		Servo Mtr. Bd. 520-5152-00		520-5082-00 Long Hop OPTO	520-5083-00 Long Hop OPTO	Alien Head Enter	
Space Jam	520-5137-01	520-5136-10	520-5138-00	520-5052-00 128 X 32 Dots	520-5055-01	520-5124-00 Single OPTO	520-5125-00 Single OPTO	5-Ball Trough over Up-Kicker	
	Miscellaneous PC Boards:	2X 7-Segment Display Board 520-5153-00							
The Star Wars Trilogy - Special Ed.	520-5137-01	520-5136-10	520-5138-00	520-5052-00 128 X 32 Dots	520-5055-01	520-5124-00 Single OPTO	520-5125-00 Single OPTO	4-Ball Trough over Up-Kicker	
	Miscellaneous PC Boards:	Relay Board 520-5010-00							
The Lost World: J.P.	520-5137-01	520-5136-10	520-5138-00	520-5052-00 128 X 32 Dots	520-5055-01	520-5124-00 Single OPTO	520-5125-00 Single OPTO	4-Ball Trough over Up-Kicker	520-5162-00 2-Pos. Motor Sensor on Snagger Motor
	Miscellaneous PC Boards:	DC Relay Bd. 520-5066-00	Shaker Mtr. Bd. 520-5065-00						
The X-Files	520-5137-01	520-5136-10	520-5138-00	520-5052-00 128 X 32 Dots	520-5055-01	520-5124-00 Single OPTO	520-5125-00 Single OPTO	4-Ball Trough over Up-Kicker	520-5155-00 3-Pos. Motor Sensor on File Cab. Motor
	Miscellaneous PC Boards:					520-5082-00 Long Hop OPTO	520-5083-00 Long Hop OPTO	File Cabinet Enter	
Starship Troopers	520-5137-01	520-5136-15	520-5138-00	520-5052-00 128 X 32 Dots	520-5055-02	520-5124-00 Single OPTO	520-5125-00 Single OPTO	4-Ball Trough over Up-Kicker	
	Miscellaneous PC Boards:	4X 7-Segment Display Board 520-5166-00				520-5082-00 Long Hop OPTO	520-5083-01 Long Hop OPTO	L/R Orbit Lane Enter	
Viper Night Drivin'	520-5137-01	520-5136-16	520-5138-00	520-5052-00 128 X 32 Dots	520-5055-03	520-5124-00 Single OPTO	520-5125-00 Single OPTO	4-Ball Trough over Up-Kicker	
	Miscellaneous PC Boards:	Relay Board 520-5010-00				520-5082-00 Long Hop OPTO	520-5083-01 Long Hop OPTO	Jump Ramp	
Lost In Space	520-5137-01	520-5136-16	520-5138-00	520-5052-00 128 X 32 Dots	520-5055-03	515-0173-00 Dual OPTO	515-0174-00 Dual OPTO	4-Ball Trough over Up-Kicker	
	Miscellaneous PC Boards:	Relay Board 520-5010-00							
Godzilla	520-5137-01	520-5136-16	520-5138-00	520-5052-00 128 X 32 Dots	520-5055-03	515-0173-00 Dual OPTO	515-0174-00 Dual OPTO	4-Ball Trough over Up-Kicker	
	Miscellaneous PC Boards:	Shaker Mtr. Bd. 520-5065-00							
South Park	520-5137-01	520-5136-16	520-5138-00	520-5052-00 128 X 32 Dots	520-5055-03	515-0173-00 Dual OPTO	515-0174-00 Dual OPTO	5-Ball Trough over Up-Kicker	
	Miscellaneous PC Boards:					520-5082-00 Long Hop OPTO	520-5083-01 Long Hop OPTO	Kenny Under Trough Enter	
Harley-Davidson® 1st-3rd* Editions	520-5137-01	520-5136-16 *520-5300-00*	520-5138-00	520-5052-00 128 X 32 Dots	520-5055-03	515-0173-00 Dual OPTO	515-0174-00 Dual OPTO	4-Ball Trough over Up-Kicker	
	Miscellaneous PC Boards:	Relay Board 520-5010-00		Shaker Mtr. Bd. 520-5065-00	Diode Board 520-5146-00	520-5082-00 Long Hop OPTO	520-5083-01 Long Hop OPTO	Motorcycle Enter	
Striker Xtreme (NFL)	520-5137-01	520-5136-16	520-5138-00	520-5052-00 128 X 32 Dots	520-5055-03	515-0173-00 Dual OPTO	515-0174-00 Dual OPTO	4-Ball Trough over Up-Kicker	520-5155-00 3-Pos. Motor Sensor on Goalie Motor
	Miscellaneous PC Boards:	DC Relay Bd. 520-5066-00	Relay Board 520-5010-00	Diode Board 520-5146-00	for UK ONLY- Solenoid Expander Bd. 520-5192-00	520-5082-00 Long Hop OPTO	520-5083-01 Long Hop OPTO	Goalie Under- Trough Enter	
Sharkey's Shootout	520-5137-64	520-5136-64	520-5138-00	520-5052-00 128 X 32 Dots	520-5055-03	515-0173-00 Dual OPTO	515-0174-00 Dual OPTO	4-Ball Trough over Up-Kicker	520-5194-00 4-Pos. Motor Sensor on ? -Ball Motor
	Miscellaneous PC Boards:	Relay Board 520-5010-00		Sol. Exp. Bd. 520-5192-00					
High Roller Casino	520-5137-01	520-5136-16	520-5138-00	520-5052-00 128 X 32 Dots	520-5055-03	515-0173-00 Dual OPTO	515-0174-00 Dual OPTO	4-Ball Trough over Up-Kicker	520-5194-00 4-Pos. Motor Sensor on Roulette Wheel Motor
	Miscellaneous PC Boards:	Dot Display (5X7) in Slot Mach. 520-5197-00			for UK ONLY- Solenoid Expander Bd. 520-5192-00	520-5196-00 3-Pos. OPTO	520-5195-00 3-Pos. OPTO	Ball Lock under Roulette	Up/Dn Ramp in Slot Mach.
Austin Powers™	520-5137-01	520-5136-16	520-5138-00	520-5052-00 128 X 32 Dots	520-5055-03	515-0173-00 Dual OPTO	515-0174-00 Dual OPTO	4-Ball Trough over Up-Kicker	520-5212-00 Pulse-Stretcher OPTO on Spini-Me
	Miscellaneous PC Boards:	Relay Bd. (X3) 520-5010-00			for UK ONLY- Solenoid Expander Bd. 520-5192-00	520-5082-00 Long Hop OPTO	520-5083-01 Long Hop OPTO	Time Machine Ramp	
MONOPOLY®	520-5137-01	520-5136-16	520-5138-00	520-5052-00 128 X 32 Dots	520-5055-03	515-0173-00 Dual OPTO	515-0174-00 Dual OPTO	4-Ball Trough over Up-Kicker	
	Miscellaneous PC Boards:	DC Relay Bd. 520-5066-00	Mini-Dot Display (3 by 5X7) 520-5197-00 (Electric C Sign)		for UK ONLY- Solenoid Expander Bd. 520-5192-00	520-5218-00 4-Pos. OPTO	520-5210-00 4-Pos. OPTO	Bank Door	

Table continued on the next page.





APPENDIX D

Board Type (White Star Board System* & S.A.M. System** Only) Table



Game Name	I/O Power Driver	CPU/Sound (old & new)	Disp. Power Supply	Dot Matrix Display	Display Controller	OPTO Transmitter	OPTO Receiver	OPTO Application	Misc OPTO & App.
Playboy	520-5137-01	520-5136-16	520-5138-00	520-5052-00 128 X 32 Dots	520-5055-03	515-0173-00 Dual OPTO	515-0174-00 Dual OPTO	4-Ball Trough over Up-Kicker	
	Miscellaneous PC Boards:	DC Relay Bd. 520-5066-00	Relay Bd. 520-5010-00		for UK ONLY- Solenoid Expander Bd. 520-5192-00				
RollerCoaster Tycoon™	520-5137-01	520-5136-16	520-5138-00	520-5052-00 128 X 32 Dots	520-5055-03	515-0173-00 Dual OPTO	515-0174-00 Dual OPTO	4-Ball Trough over Up-Kicker	520-5222-00 1-Position Switch Detect on Wheel Spin
	Miscellaneous PC Boards:	DC Relay Bd. 520-5066-00	Mini-Dot Display (3 by 5X7) 520-5221-00 (Ramp Enter Sign)		for UK ONLY- Solenoid Expander Bd. 520-5192-00	520-5082-00 Long Hop opto	520-5083-01 Long Hop opto	Behind 1-Bank Drop Target	
The Simpsons™ Pinball Party	520-5137-01	520-5136-16	520-5138-00	520-5052-00 128 X 32 Dots	520-5055-03	515-0173-00 Dual OPTO	515-0174-00 Dual OPTO	4-Ball Trough over Up-Kicker	
	Miscellaneous PC Boards:	LED Bd. 520-5219-00	Color Dot Display (4 by 5X7) 520-5225-00 (TV Set)		for UK ONLY ◀◀◀ Aux. Driver Bd. 520-5068-01				
Terminator® 3: Rise of the Machines™	520-5137-01	520-5136-16	520-5138-00	520-5052-00 128 X 32 Dots	520-5055-03	515-0173-00 Dual OPTO	515-0174-00 Dual OPTO	4-Ball Trough over Up-Kicker	
	Miscellaneous PC Boards:				for UK ONLY ◀◀◀ Aux. Driver Bd. 520-5068-01	515-7307-00 Single OPTO	515-7308-00 Single OPTO	TXCannon Trough	
The Lord of the Rings™	520-5137-01	New 520-5300-00	520-5138-00	520-5052-00 128 X 32 Dots	520-5055-03	515-0173-00 Dual OPTO	515-0174-00 Dual OPTO	4-Ball Trough over Up-Kicker	500-6746-00 (White Trans.) 500-6747-00 (Black Rec.)
	Miscellaneous PC Boards:	19-LED PCB 520-5242-00	OPTO Transmitter / Receiver Amplifier PCB 520-5239-00		for UK ONLY ◀◀◀ Aux. Driver Bd. 520-5068-01	515-7307-00 Single OPTO	515-7308-00 Single OPTO	Orthanc Tower Trough	
Ripley's Believe It or Not!®	520-5137-01	520-5300-00	520-5138-00	520-5052-00 128 X 32 Dots	520-5055-03	515-0173-00 Dual OPTO	515-0174-00 Dual OPTO	4-Ball Trough over Up-Kicker	500-6775-00 OPTO Trnscvr
	Miscellaneous PC Boards:	520-5236-00 X3 Dot Display	OPTO Transmitter / Receiver Amplifier PCB 520-5239-01		for UK ONLY ◀◀◀ Aux. Driver Bd. 520-5068-01	520-5234-00 3-Pos. OPTO	520-5234-00 3-Pos. OPTO	Vari-Target	520-5235-03 X3 Aux. Drvr
Elvis®	520-5137-01	520-5300-00	520-5138-00	520-5052-00 128 X 32 Dots	520-5055-03	515-0173-00 Dual OPTO	515-0174-00 Dual OPTO	4-Ball Trough over Up-Kicker	
	Miscellaneous PC Boards:				for UK ONLY ◀◀◀ Aux. Driver Bd. 520-5068-01				
The Sopranos™	520-5137-01	520-5300-00	520-5138-00	520-5052-00 128 X 32 Dots	520-5055-03	515-0173-00 Dual OPTO	515-0174-00 Dual OPTO	4-Ball Trough over Up-Kicker	
	Miscellaneous PC Boards:				for UK ONLY ◀◀◀ Aux. Driver Bd. 520-5068-01				
NASCAR® and [NDSE]	520-5137-01	520-5300-00	520-5138-00	520-5052-00 128 X 32 Dots	520-5055-03	515-0173-00 Dual OPTO	515-0174-00 Dual OPTO	4-Ball Trough over Up-Kicker	500-6775-00 OPTO Trans. (Qty. 16) Switch Detect.
	Miscellaneous PC Boards:	520-5235-03 X3 Aux. Drvr	OPTO Transmitter / Receiver Amplifier PCB 520-5239-01		for UK ONLY ◀◀◀ Aux. Driver Bd. 520-5068-01				
Grand Prix	520-5137-01	520-5300-00	520-5138-00	520-5052-00 128 X 32 Dots	520-5055-03	515-0173-00 Dual OPTO	515-0174-00 Dual OPTO	4-Ball Trough over Up-Kicker	500-6775-00 OPTO Trans. (Qty. 16) Switch Detect.
	Miscellaneous PC Boards:	520-5235-03 X3 Aux. Drvr	OPTO Transmitter / Receiver Amplifier PCB 520-5239-01		for UK ONLY ◀◀◀ Aux. Driver Bd. 520-5068-01				

Game Name	I/O Power Driver**	CPU / Sound**	Disp. Power Supply	Dot Matrix Display	Dual OPTO Transmitter	Dual OPTO Receiver	Dual OPTO Transceiver	OPTO Transceiver Miscellaneous
World Poker Tour™ (WPT)	520-5249-00 Backbox	520-5246-00 Backbox	520-5138-00 Backbox	520-5052-00 128 X 32 Dots	515-0173-00 4-Ball Trough	515-0174-00 4-Ball Trough	500-6775-00 4 Switch Pairs (Qty. 8)	520-5251-00 'U' 1/per PCB Jail Bars Up Ace/Hole Mech 520-5252-04 'U' 4/per PCB Drop Targets 4- & 8- Banks
	Miscellaneous PCBs:	520-5254-00 50V Step-Up Drv	520-5250-14 14LED 5X7 Disp.	520-5239-01 OPTO Amplifier	520-5247-00 Ace/Hole Mech	520-5248-00 Ace/Hole Mech		
The Simpsons™ Kooky Carnival	520-5249-00 Back Door	520-5246-00 Back Door	520-5138-00 Cabinet Rear	520-5052-00 128 X 32 Dots			520-5253-00-ASY Coin Drop (Qty. 11)	
	Miscellaneous PCBs:	515-5742-00 Shaker PCB	500-6700-00 Relay (incl. Wiring + Conn.)					
©Disney's Pirates of the Caribbean	520-5249-00 Backbox	520-5246-00 Backbox	520-5138-00 Backbox	520-5052-00 128 X 32 Dots	515-0173-00 4-Ball Trough	515-0174-00 4-Ball Trough	500-6775-00 5 Switch Pairs (Qty. 10)	
	Miscellaneous PCBs:	520-5239-01 OPTO Amp. (X3)	511-5024-03 Relay (incl. Wiring + Conn.)	520-5238-00 : H-E-A-R-T LED PCB				
Family Guy™	520-5249-00 Backbox	520-5246-00 Backbox	520-5138-00 Backbox	520-5052-00 128 X 32 Dots	515-0173-00 4-Ball Trough	515-0174-00 4-Ball Trough	500-6775-00 3 Switch Pairs (Qty. 6)	520-5252-01 'U' 1/per PCB Drop Target 1-Bank
	Miscellaneous PCBs:	520-5239-01 OPTO Amp. (X2)	520-5261-00 Stepper Motor	511-5042-01 Trgt. Sensor (X2)			500-6775-01 1 Switch Pair (Qty. 2)	520-5252-04 'U' 4/per PCB Drop Target 4-Bank
Spider-Man™	520-5249-00 Backbox	520-5246-00 Backbox	520-5138-00 Backbox	520-5052-00 128 X 32 Dots	515-0173-00 4-Ball Trough	515-0174-00 4-Ball Trough	500-6775-00 3 Switch Pairs (Qty. 6)	
	Miscellaneous PCBs:	520-5239-01 OPTO Amp. (X2)						



APPENDIX D

Board Type Table

Game Name	Flipper	Sound	Power Supply	Display X-Digit
• Laser War	2-Flipper Board Not Required	<i>initial:</i> 520-5002-00 <i>replaced with:</i> 520-5002-02 <i>520-5002-01 was not used.</i>	520-5000-00	Master: 520-5004-00 plus: 520-5005-00 (Qty. 2): 7 Digit Alpha/Numeric 520-5006-00 (Qty. 2): 7 Digit Numeric 520-5007-00 (Qty. 1): 4 Digit Numeric
• Secret Service • Torpedo Alley	3-Flipper Board Not Required	520-5002-02		520-5014-01 7 Digit Alpha/Numeric Combined
• Time Machine	2-Flipper Board Not Required			520-5030-00 16 Digit Alpha/Numeric Combined
• Playboy 35th Anniversary *	520-5033-00 2-Flipper <i>(*only for 100 games of Playboy 35th Anniv. & ABC Mon. Night Football)</i>			
• ABC Monday Night Football *				
• Robocop				
• Phantom of the Opera				
• Back to the Future		520-5002-03		
• The Simpsons				

Game Name	Flipper	Sound	Power Supply	Dot Matrix Display	Display Controller	OPTO Transmitter	OPTO Receiver	OPTO Application
• Checkpoint • Teenage Mutant Ninja Turtles	520-5033-00 2-Flipper	520-5002-03	520-5047-00	520-5042-00 128 X 16	520-5055-00			
• Batman • Star Trek 25th Anniv. • Hook		520-5050-01						
• Lethal Weapon 3		520-5050-02	520-5047-01					
• Star Wars • Rocky & Bullwinkle & Friends			520-5052-00 128 X 32					
• Jurassic Park		520-5076-00 3-Flipper		520-5047-02				
• Last Action Hero		520-5070-00 2-Flipper	520-5050-03					
• Tales from the Crypt		520-5076-00 3-Flipper		520-5077-00				
• The Who's Tommy		520-5070 / 5080 -00 4-Flipper (2X2)	520-5077-00					
• WWF Royal Rumble		520-5076-00 3-Flipper		520-5050-03				
• Guns N' Roses		520-5076-00 3-Flipper	520-5077-00					
• Maverick	520-5076-00 3-Flipper	520-5050-03						
• Mary Shelley's Frankenstein	520-5076-00 3-Flipper		520-5077-00					
• Baywatch	520-5070 / 5080 -00 4-Flipper (2X2)	520-5126-02						
• Batman Forever	520-5076-00 3-Flipper		520-5047-03					
				520-5075-00 192 X 64	520-5092-01	520-5102-00 Single OPTO	520-5103-00 Single OPTO	Paddle Boat Wheel Enter
					520-5124-00 Single OPTO	520-5125-00 Single OPTO	5-Ball Trough over Up-Kicker	
					520-5124-00 Single OPTO	520-5125-00 Single OPTO	4-Ball Trough over Up-Kicker	

Miscellaneous Boards (Lamp Boards & Relay Boards) not listed above can be found in each individual game manual.





APPENDIX E

Flipper Coil (White Star Board System* & S.A.M. System** Only) Table



Typical Coil Diode 1N4004 unless noted otherwise (Diode Top = above lugs next to windings; Diode Below (Bottom) = under lugs opposite of windings).

STANDARD COILS (TYPICAL APPLICATIONS)			LARGE COILS (FLIPPERS & SPECIAL APPLICATIONS)		
Ga.-Turn	Res (Ω)	SPI Part Number and Comments	Ga.-Turn	Res (Ω)	SPI Part Number and Comments
20-400	1.0 Ω	090-5021-use: -00 Diode Top	21-900	call Ω	090-5020-use: -01 3-Lugs + 1N4004 & 1N5404 Diodes -10 Diode Top <BROWN><RED>
22-500	1.7 Ω	090-5017-use: -00 Diode Top	22-750 / 30-2600	2.6 Ω 92.0 Ω	090-5011-use: -00 DUAL WND COIL // 3-Lugs Diode x2
22-600	2.2 Ω	090-5017-use: -0B Diode Below // -0T Diode Top			
23-700	3.1 Ω	090-5022-use: -0B Diode Below // -0T Diode Top	22-900	3.45 Ω	090-5020-use: -20T Diode Top <YELLOW> // -20-ND No Diode
23-750	3.4 Ω	090-5019-use: -00 Diode Top			
23-800	3.6 Ω	090-5001-use: -0B Diode Below // -0T Diode Top // -NL No Lugs 11" Leads // -ND No Diode	22-1080	4.2 Ω	090-5032-use: -0B D. Below // -0T D. Top <YEL-GRN> -NL No Diode
23-840	4.0 Ω	090-5005-use: -00 Diode Top			
23.5-765	3.6 Ω	090-5037-use: -03 Diode Top	23-620 / 30-2600	2.4 Ω 75.0 Ω	090-5006-use: -00 DUAL WND COIL // 3-Lugs Diode x2
24-900	5.0 Ω	090-5002-use: -02 Diode Top // -10 No Lugs 14" Leads			
24-940	5.5 Ω	090-5036-use: -0B Diode Below // -0T Diode Top use 090-5051-01 No Lugs 11" Leads	23-700 / 30-2600	3.0 Ω 83.5 Ω	090-5013-use: -00 DUAL WOUND COIL // Diode Top
25-1240	9.3 Ω	090-5034-use: -00 Diode Below			
26-1200	10.3 Ω	090-5044-use: -0B Diode Below // -0T Diode Top // -NL No Lugs 11" Leads // -ND No Diode	23-800 / 30-2600	2.4 Ω 90.5 Ω	090-5012-use: -00 DUAL WOUND COIL // Diode Top
27-1300	14.2 Ω	090-5003-use: -0T Diode Top			
27-1400		090-5015-use: -00 Diode Below	23-1100	5.1 Ω	090-5030-use: -0T Diode Top <ORANGE> -ND No Diode
27-1400	14.7 Ω	511-5031-00 Special App.: No Diode / Lugs + Conn.			
27-1500	16.3 Ω	090-5004-use: -0B Diode Below // -0T Diode Top	23-1200	7.1 Ω	090-5008-use: -00 Diode Top <BLACK>
29-2000	33.6 Ω	090-5016-use: -00 Diode Top	23-1500	4.4 Ω	090-5062-use: -00 Diode Top <BLUE>
LARGE, MEDIUM & MINI COILS (MAGNET APPLICATIONS)			24-1570	9.5 Ω	090-5025-use: -00 Diode Top <BLUE>
20.5-480	2.9 Ω	090-5064-use: -02 No Lugs or Core; 14" Leads // Large	25-1400	call Ω	090-5067-use: -0T Diode Top <RED>
22-650	4.3 Ω	090-5042-use: -00 No Lugs or Core; 6" Leads // Large	25-1600	call Ω	090-5068-use: -0T Diode Top <WHITE>
		090-5042-use: -01 No Lugs or Core; 12" Leads // Large	25-1800	13.8 Ω	090-5041-use: -0T Diode Top <BLUE-GREEN>
24-780	8.0 Ω	090-5061-use: -00 No Lugs or Core; 6" Lds. // Medium	MINI COILS (RESET / TRIP APPLICATIONS)		
29-1000	15.2 Ω	090-5059-use: -00 Lugs + Diode + Magnet Core // Mini	27-950	call Ω	090-5046-use: -01 Diode Top
31-1500	52.0 Ω	090-5054-00: Straight Lugs + Diode + Mag Core // Mini	28-1050	11.5 Ω	090-5046-use: -00 Diode Top
		090-5055-00: 90° Lugs + Diode + Magnet Core // Mini	27-880	call Ω	500-6976-01 No Lugs or Diode + 6" Leads & Conn.
Please Note: Ohm values may vary +/- .03 depending on meter calibration.			31-590	call Ω	090-5010-use: -00 Diode Top
Ordering Note: Coils typically should not come with Coil Sleeves. IF A SLEEVE EXISTS, ensure it is the correct sleeve for the application usage. For the correct Coil Sleeve, refer to the Game Assembly Drawing the coil exists on and order separately.			32-1250	35.0 Ω	515-6916-01: includes Flap & Screw <YELLOW>
			32-1800	50.2 Ω	090-5031-use: -0B Diode Below // -0T Diode Top (515-6110-00) use 515-# to include mounting & armature brackets
			33-1590	59.0 Ω	515-6916-00: includes brackets <WHITE>

Flipper Coil (White Star Board System* Only) Table

GAME NAME	Nº of Flippers	FLIPPERS		FLIPPERS no E.O.S. Switch	
		SPI Nº / GAUGE-TURNS / Color		SPI Nº / GAUGE-TURNS / Color	
		LOWER LEFT	LOWER RIGHT	UPPER LEFT	UPPER RIGHT
Apollo 13	2	090-5032-0T 22-1080 -YEL-GRN-	SAME	Not Used	Not Used
Golden Eye	2	090-5032-0T 22-1080 -YEL-GRN-	SAME	Not Used	Not Used
Twister	2	090-5020-20T 22-900 -YELLOW-	090-5032-0T 22-1080 -YEL-GRN-	Not Used	Not Used
ID4: Independence Day	3	090-5032-0T 22-1080 -YEL-GRN-	SAME	Not Used	090-5020-30 23-900 -GREEN-
Space Jam †	2	090-5032-0T 22-1080 -YEL-GRN-	090-5020-20T 22-900 -YELLOW-	Not Used	Not Used
The Star Wars Trilogy - Special Edition †	2	090-5032-0T 22-1080 -YEL-GRN-	SAME	Not Used	Not Used
The Lost World: Jurassic Park †	2	090-5032-0T 22-1080 -YEL-GRN-	SAME	Not Used	Not Used
The X-Files †	2	090-5032-0T 22-1080 -YEL-GRN-	SAME	Not Used	Not Used
Starship Troopers †	3	090-5030-0T 23-1100 -ORANGE-	SAME	Not Used	090-5032-0T 22-1080 -YEL-GRN-
Viper Night Drivin' †	2	090-5030-0T 23-1100 -ORANGE-	SAME	Not Used	Not Used
Lost In Space †	2	090-5030-0T 23-1100 -ORANGE-	090-5032-0T 22-1080 -YEL-GRN-	Not Used	Not Used
Godzilla †	2	090-5032-0T 22-1080 -YEL-GRN-	SAME	Not Used	Not Used
South Park †	2	090-5030-0T 23-1100 -ORANGE-	SAME	Not Used	Not Used

† Coil Part Numbers ending with a "T" signifies the Diode is on the top of the lug (on the coil-winding side); Coil Part Numbers ending with a "B" signifies the Diode is on the bottom of the lugs.

Table continued on the next page.





APPENDIX E

Flipper Coil (White Star Board System* & S.A.M. System** Only) Table



GAME NAME	N ^o of Flippers	FLIPPERS w/E.O.S. Switch		FLIPPERS no E.O.S. Switch	
		SPI N ^o / GAUGE-TURNS / Color		SPI N ^o / GAUGE-TURNS / Color	
		LOWER LEFT	LOWER RIGHT	UPPER LEFT	UPPER RIGHT
Harley-Davidson® † and 1st through 3rd Editions	2	090-5032-0T 22-1080 -YEL-GRN-	090-5030-0T 23-1100 -ORANGE-	Not Used	Not Used
Striker Xtreme (NFL) †	3	090-5032-0T 22-1080 -YEL-GRN-	090-5030-0T 23-1100 -ORANGE-	090-5030-0T 23-1100 -ORANGE-	Not Used
Sharkey's Shootout †	3	090-5030-0T 23-1100 -ORANGE-	SAME	090-5030-0T 23-1100 -ORANGE-	Not Used
High Roller Casino †	2	090-5032-20T 22-900 -YELLOW-	090-5032-0T 22-1080 -YEL-GRN-	Not Used	Not Used
Austin Powers™ †	2	090-5020-30 23-900 -GREEN-	090-5030-0T 23-1100 -ORANGE-	Not Used	Not Used
MONOPOLY® †	3	090-5032-0T 22-1080 -YEL-GRN-	SAME	Not Used	090-5062-0T 23-1500 -BLUE-
Playboy †	2	090-5030-0T 23-1100 -ORANGE-	SAME	Not Used	Not Used
RollerCoaster Tycoon™ †	4	090-5032-0T 22-1080 -YEL-GRN-	SAME	090-5067-0T 25-1400 -RED-	090-5068-0T 25-1600 -WHITE-
The Simpsons™ Pinball Party †	6** (5 with Flipper Bats)	** The Homer Head Assembly is affixed to an Upr. Rt. Style Flipper (no E.O.S. Switch):		Flippers (Mini-Bats) on 2nd Level Playfield:	
			** 090-5020-20T 22-900 -YELLOW-	090-5041-00T 25-1800 -BLU-GRN-	090-5025-00 24-1570 -BLUE-
Terminator® 3: Rise of the Machines™ †	2	090-5032-0T 22-1080 -YEL-GRN-	SAME	Not Used	Not Used
The Lord of the Rings™ †	2	090-5020-20T 22-900 -YELLOW-	SAME	Not Used	Not Used
Ripley's Believe It or Not!® †	3	090-5032-0T 22-1080 -YEL-GRN-	SAME	Not Used	090-5067-00T 25-1400 -RED-
Elvis® †	4	090-5020-20T 22-900 -YELLOW-	SAME	090-5020-30 23-900 -GREEN-	SAME
The Sopranos™ †	2	090-5032-0T 22-1080 -YEL-GRN-	SAME	Not Used	Not Used
NASCAR® and [NDSE] †	2	090-5030-0T 23-1100 -ORANGE-	SAME	Not Used	Not Used
Grand Prix †	2	090-5030-0T 23-1100 -ORANGE-	SAME	Not Used	Not Used
† Coil Part Numbers ending with a "T" signifies the Diode is on the top of the lug (on the coil-winding side); Coil Part Numbers ending with a "B" signifies the Diode is on the bottom of the lugs.					
** S.A.M. System Games DO NOT REQUIRE DIODES. If you use a coil from your stock which has a diode, remove it ONLY FOR S.A.M. System Games.					
World Poker Tour™ (WPT)**	4	090-5032-ND 22-1080 [NO DIODE]	SAME	090-5030-ND 23-1100 [NO DIODE]	SAME
©Disney's Pirates of the Caribbean**	2	090-5030-ND 23-1100 [NO DIODE]	SAME	Not Used	Not Used
Family Guy™ **	3 Norm.	090-5030-ND 23-1100 [NO DIODE]	SAME	090-5062-ND 23-1500 [NO DIODE]	Not Used
	2 Mini	090-5046-01-ND 27-950 [NO DIODE]	SAME		
Spider-Man™ **	3	090-5032-ND 22-1080 [NO DIODE]	SAME	Not Used	090-5032-ND 22-1080 [NO DIODE]



APPENDIX E

Generic Coil Cross-Reference Guide † ‡

Flipper Coil Table † ‡ ††

GAME NAME	Nº of Flippers	FLIPPERS w/E.O.S. Switch		FLIPPERS no E.O.S. Switch	
		SPI Nº / GAUGE-TURNS / Color		SPI Nº / GAUGE-TURNS / Color	
		LOWER LEFT	LOWER RIGHT	UPPER LEFT	UPPER RIGHT
Laser War ‡	2	090-5011-00 22-750 / 30-2600	SAME	Not Used	Not Used
Secret Service ‡	3	090-5006-00 23-620 / 30-2600	SAME	Not Used	090-5006-00 23-620 / 30-2600
Torpedo Alley ‡	3	090-5011-00 22-750 / 30-2600	090-5013-00 23-700 / 30-2600	Not Used	090-5012-00 23-800 / 30-2600
Time Machine ‡	2	090-5011-00 22-750 / 30-2600	SAME	Not Used	Not Used
‡ These coils are dual-wound.					
Playboy 35th Anniversary ††	2	090-5020-02 22-900 -YEL-YEL-	SAME	Not Used	Not Used
ABC Monday Night Football ††	2	090-5020-02 22-900 -YEL-YEL-	SAME	Not Used	Not Used
†† A very small % of these games used a 090-5020-20 coil which used a proto-type Solid State Flipper System. The two types of coils both are 22-900 coils; the only difference is the addition of the 1N5404 Diode on the (-02) coils which was used in the Deger Design.					
Robocop	2	090-5020-20 22-900 -YEL-YEL-	SAME	Not Used	Not Used
Phantom of the Opera	2	090-5020-20 22-900 -YEL-YEL-	SAME	Not Used	Not Used
Back to the Future	2	090-5020-20 22-900 -YEL-YEL-	SAME	Not Used	Not Used
The Simpsons	2	090-5020-20 22-900 -YEL-YEL-	SAME	Not Used	Not Used
Checkpoint	2	090-5020-20 22-900 -YEL-YEL-	SAME	Not Used	Not Used
Teenage Mutant Ninja Turtles	2	090-5020-30 23-900 -GRN-GRN-	SAME	Not Used	Not Used
Batman	2	090-5020-30 23-900 -GRN-GRN-	SAME	Not Used	Not Used
Star Trek 25th Anniversary	2	090-5020-30 23-900 -GRN-GRN-	SAME	Not Used	Not Used
Hook	2	090-5030-00 23-1100 -ORG-ORG-	090-5020-30 23-900 -GRN-GRN-	Not Used	Not Used
Lethal Weapon 3	2	090-5030-00 23-1100 -ORG-ORG-	SAME	Not Used	Not Used
Star Wars	2	090-5032-00 22-1080 -YEL-GRN-	SAME	Not Used	Not Used
Rocky & Bullwinkle & Friends	2	090-5020-30 23-900 -GRN-GRN-	SAME	Not Used	Not Used
Jurassic Park	3	090-5020-30 23-900 -GRN-GRN-	SAME	Not Used	090-5030-00 23-1100 -ORG-ORG-

Table continued on the next page.



APPENDIX E

Flipper Coil Table †

GAME NAME	N ^o of Flippers	FLIPPERS w/ E.O.S. Switch		FLIPPERS no E.O.S. Switch	
		SPI N ^o / GAUGE-TURNS / Color		SPI N ^o / GAUGE-TURNS / Color	
		LOWER LEFT	LOWER RIGHT	UPPER LEFT	UPPER RIGHT
Last Action Hero	2	090-5020-30 23-900 -GRN-GRN-	SAME	Not Used	Not Used
Tales from the Crypt	3	090-5032-00 22-1080 -YEL-GRN-	SAME	Not Used	090-5041-00 25-1800 -BLU-GRN-
The Who's Tommy	3	090-5020-30 23-900 -GRN-GRN-	SAME	090-5041-00 25-1800 -BLU-GRN-	Not Used
WWF Royal Rumble	4	090-5032-00 22-1080 -YEL-GRN-	SAME	090-5041-00 25-1800 -BLU-GRN-	SAME
Guns N' Roses	3	090-5032-00 22-1080 -YEL-GRN-	SAME	090-5030-00 23-1100 -ORG-ORG-	Not Used
Maverick	3	090-5032-00 22-1080 -YEL-GRN-	SAME	Not Used	090-5032-00 22-1080 -YEL-GRN-
Mary Shelley's Frankenstein	3	090-5030-00 23-1100 -ORG-ORG-	SAME	Not Used	090-5030-00 23-1100 -ORG-ORG-
Baywatch	4	090-5030-00 23-1100 -ORG-ORG-	090-5020-30 23-900 -GRN-GRN-	090-5025-00 24-1570 -See Note-	090-5030-00 23-1100 -ORG-ORG-
Batman Forever	3	090-5032-00 22-1080 -YEL-GRN-	090-5020-20 22-900 -YEL-YEL-	Not Used	090-5020-30 23-900 -GRN-GRN-
Apollo 13	2	090-5032-00 22-1080 -YEL-GRN-	SAME	Not Used	Not Used
Golden Eye	2	090-5032-00 22-1080 -YEL-GRN-	SAME	Not Used	Not Used
Twister	2	090-5020-20 22-900 -YEL-YEL-	090-5032-00 22-1080 -YEL-GRN-	Not Used	Not Used
ID4: Independence Day	3	090-5032-00 22-1080 -YEL-GRN-	SAME	Not Used	090-5020-30 23-900 -GRN-GRN-
Space Jam †	2	090-5032-00T 22-1080 -YEL-GRN-	090-5020-20T 22-900 -YEL-YEL-	Not Used	Not Used
The Star Wars Trilogy - Special Edition †	2	090-5032-00T 22-1080 -YEL-GRN-	SAME	Not Used	Not Used
The Lost World: Jurassic Park †	2	090-5032-00T 22-1080 -YEL-GRN-	SAME	Not Used	Not Used
The X-Files †	2	090-5032-00T 22-1080 -YEL-GRN-	SAME	Not Used	Not Used
Starship Troopers †	3	090-5030-00T 23-1100 -ORG-ORG-	SAME	Not Used	090-5032-00T 22-1080 -YEL-GRN-
Viper Night Drivin' †	2	090-5030-00T 23-1100 -ORG-ORG-	SAME	Not Used	Not Used
Lost In Space †	2	090-5030-00T 23-1100 -ORG-ORG-	090-5032-00T 22-1080 -YEL-GRN-	Not Used	Not Used
Godzilla †	2	090-5032-00T 22-1080 -YEL-GRN-	SAME	Not Used	Not Used
South Park †	2	090-5030-00T 23-1100 -ORG-ORG-	SAME	Not Used	Not Used
Harley-Davidson® † and Harley-Davidson® 2nd Ed. †	2	090-5032-00T 22-1080 -YEL-GRN-	090-5030-00T 23-1100 -ORG-ORG-	Not Used	Not Used
Striker Xtreme (NFL) †	3	090-5032-00T 22-1080 -YEL-GRN-	090-5030-00T 23-1100 -ORG-ORG-	090-5030-00T 23-1100 -ORG-ORG-	Not Used
Sharkey's Shootout †	3	090-5030-00T 23-1100 -ORG-ORG-	SAME	090-5030-00T 23-1100 -ORG-ORG-	Not Used
High Roller Casino †	2	090-5020-20T 22-900 -YEL-YEL-	090-5032-00T 23-1080 -YEL-GRN-	Not Used	Not Used
Austin Powers™ †	2	090-5020-30 23-900 -GRN-GRN-	090-5030-00T 23-1100 -ORG-ORG-	Not Used	Not Used
MONOPOLY® †	3	090-5032-00T 22-1080 -YEL-GRN-	SAME	Not Used	090-5062-00T 23-1500 -BLU-BLU-
Playboy †	2	090-5030-00T 23-1100 -ORG-ORG-	SAME	Not Used	Not Used
RollerCoaster Tycoon™ †	4	090-5032-00T 22-1080 -YEL-GRN-	SAME	090-5067-00T 25-1400 -RED-RED-	090-5068-00T 25-1600 -WHT-WHT
The Simpsons™ Pinball Party †	6* (5 with Flipper Bats)	090-5032-00T 22-1080 -YEL-GRN-	SAME	Not Used	090-5030-00T 23-1100 -ORG-ORG-
		* The Homer Head Assembly is affixed to an Upr. Rt. Style Flipper (no E.O.S. Switch):		Flippers (Mini-Bats) on 2nd Level Playfield:	
			* 090-5020-20T 22-900 -YEL-YEL-	090-5041-00T 25-1800 -BLU-GRN-	090-5025-00T 24-1570 -See Note-
Terminator® 3: Rise of the Machines™ †	2	090-5032-00T 22-1080 -YEL-GRN-	SAME	Not Used	Not Used
The Lord of the Rings™ †	2	090-5020-20T 22-900 -YEL-YEL-	SAME	Not Used	Not Used
Ripley's Believe It or Not!® †	3	090-5032-00T 22-1080 -YEL-GRN-	SAME	Not Used	090-5067-00T 25-1400 -RED-RED-

† Coil Part N^os ending with a "T" signifies the Diode is on the top of the lug (on the coil-winding side); Coil Part N^os ending with a "B" signifies the Diode is on the bottom of the lugs.



APPENDIX F

Motor Specification (White Star Board System* Only) Table



Game Name	Function	Specifications	Part Number
Apollo 13	Rocket Up/Down Movement	Bowman Motor 24VAC 60Hz 3W 6 RPM CCW	515-6383-00 <i>incl. Connector</i>
	Moon Unit Rotational Orbit	Multi Products Motor 24VAC 50/60Hz 3W 6 RPM CCW	515-6487-00 <i>incl. Connector</i>
	Shaker	Johnson Motor (Vibrator) 10.5VDC 10 AMP 2950 RPM CW	041-5029-00 MOTOR ONLY
Golden Eye	Satellite Left/Right Movement	Bowman Motor 24VAC 60Hz 3W 6 RPM CW	515-6528-00 <i>incl. Connector</i>
Twister	Spinning Disc with Magnet	Multi Products Motor 24VAC (041-5026-00) 50/60Hz 3W 325 RPM CCW	515-6347-00 <i>incl. Connector</i>
	Backbox Fan (Tornado Wind)	Multi Products Motor 24VAC (041-5052-00) 50/60Hz 3W 3600 RPM CW	515-6531-00 <i>incl. Connector</i>
ID4: Independence Day	Alien Head Open/Close Movement	Servo Motor (94322)	041-5045-00 MOTOR ONLY
<i>SPACE JAM (NO MOTOR USED)</i>			
The Star Wars Trilogy - S.E.	X-Wing Left/Right Movement	Bowman Motor 24VAC (041-5058-00) 60Hz 3W 10 RPM CCW	515-6383-01 <i>incl. Connector</i>
The Lost World: Jurassic Park	Snagger & Center Link Lift Up/Down Movement	Multi Products Motor 20VDC (041-5059-03) 9 RPM Non-Directional	515-6715-03 <i>incl. Connector</i>
	Shaker	Johnson Motor (Vibrator) 10.5VDC 10 AMP 2950 RPM CW	041-5029-00 MOTOR ONLY
The X-Files	X-File Cabinet Lift Up/Down Movement	Multi Products Motor 20VDC 9 RPM CCW	041-5057-00 MOTOR ONLY
Starship Troopers	Warrior Bug Forward/Reverse Movement	Haydon Switch & Instrument, Inc. Stepper Motor 12VDC 4.6W (041-5062-00), Series 36000: 1.4"ø (Non-Captive Shaft not included) HSI #36864-12 (Unipolar) Travel per Step: .004 Step Angle: 15°	515-6794-00 <i>incl. Connector</i> Requires 7" Shaft: 530-5503-00
<i>VIPER NIGHT DRIVIN' (NO MOTOR USED)</i>			
Lost In Space	Spinning Disc with Magnet	Multi Products Motor 24VAC (041-5046-00) 50/60Hz 3W 325 RPM CCW	515-6347-00 <i>incl. Connector</i>
Godzilla	Shaker ‡	Multi #3811 0630 Motor (Vibrator) 12VDC 3100 RPM CW (w/DRL PTS) ‡	041-5029-01 MOTOR ONLY
<i>SOUTH PARK (NO MOTOR USED)</i>			
Harley-Davidson® 1st through 3rd Editions	Shaker ‡	Multi #3811 0630 Motor (Vibrator) 12VDC 3100 RPM CW (w/DRL PTS) ‡	041-5029-01 MOTOR ONLY
	Motorcycle Lift Up/Down Movement	Autotrol 24VAC (041-5072-02) 20 RPM CCW	515-7025-00 <i>incl. Connector</i>
Striker Xtreme (NFL)	Goalie (Linebacker) Left to Right Movement	Multi #3590 12VDC (041-5075-00) 60 RPM	515-7071-00 <i>incl. Connector</i>
Sharkey's Shootout	Mystery Ball Rotating Movement	Hankscraft Motor Model-E 24VAC (041-5076-00) 50/60Hz 3W 20 RPM CW	515-7095-00 <i>incl. Connector</i>
High Roller Casino	Roulette Wheel Rotating Movement	Multi Products Motor 20VDC (041-5078-00) 17 RPM CCW	515-7153-00 <i>incl. Connector</i>
	Up/Dn. Ramp in Slot Mach. Lift Up/Down Movement	Haydon Switch & Instrument, Inc. Stepper Motor 12VDC 4.6W (041-5062-00), Series 36000: 1.4"ø (Non-Captive Shaft not included) HSI #36864-12 (Unipolar) Travel per Step: .004 Step Angle: 15°	515-6794-00 <i>incl. Connector</i> Requires Shaft 4¼": 530-5503-01
Austin Powers™	Time Machine Rotating Movement	Multi Products Motor 24VAC (041-5079-00) 50/60Hz 20RPM CCW	515-7141-00 <i>incl. Connector</i>
	Laser Beam Left to Right Directional	Autotrol Motor 24VAC (041-5081-00) 50/60Hz 4W 10RPM Bi-Directional	515-7171-00 <i>incl. Connector</i>
	Dr. Evil Target Lift Up/Down Movement	Hankscraft Motor Model-E 24VAC (041-5030-00) 50/60Hz 6RPM CCW	515-5900-00 <i>incl. Connector</i>
Monopoly®	Mini-Flipper (Waterworks) Rotating Movement	Multi Prod. Motor & Gear Box #7000 EX00159A 20VDC 50/60Hz 85RPM CC/CCW	041-5083-00 MOTOR ONLY
Playboy	Triangular Billboard Rotating Movement	Autotrol Motor (BD511 150-1387) 24VAC 50/60Hz 12RPM Bi-Directional	041-5086-02 MOTOR ONLY
	Centerfold Mechanism Open/Close Movement	Multi Products (3680) Motor 12v DC 10/12 RPM CC/CCW	041-5075-04 MOTOR ONLY
	Tease Drop Screen Lift Up/Down Movement	Haydon Switch & Instrument, Inc. Stepper Motor 12VDC 4.6W (041-5062-00), Series 36000: 1.4"ø (Non-Captive Shaft not included) HSI #36864-12 (Unipolar) Travel per Step: .004 Step Angle: 15°	515-6794-00 <i>incl. Connector</i> Requires 7" Shaft: 530-5503-00

‡ Please Note: ".01" Shaker Motor is **Not Compatible** with old Shaker Motor 041-5029-00 (Shaker Motor Assy. 515-5893-00). THIS NEW MOTOR CAN ONLY BE USED IN NEW SHAKER MOTOR ASSY. 515-5893-01.

Table continued on the next page.





APPENDIX F

Motor Specification (White Star Board System* & S.A.M. System** Only) Table



Game Name	Function	Specifications	Part Number
ROLLERCOASTER TYCOON™ (NO MOTOR USED)			
THE SIMPSONS™ PINBALL PARTY (NO MOTOR USED)			
Terminator® 3: Rise of the Machines™	Backbox Ball Shooter Up/Down Movement	Multi Products Motor 24VAC (041-5079-01) 21 RPM CW	515-7317-00 <i>incl. Connector</i>
The Lord of the Rings™	Balrog (Motor & Gate) Open/Close Movement	Multi Prod. Motor 20VDC Series 600B (or equiv.) 50/60Hz 10 RPM Bi-Directional	041-5088-01 MOTOR ONLY
RIPLEY'S BELIEVE IT OR NOT!® (NO MOTOR USED)			
Elvis®	Elvis™ Front/Back Movement	Haydon Switch & Instrument, Inc. Stepper Motor 12VDC 10W (041-5089-00), (Non-Captive Shaft not included) HSI #46868-12-002	500-6809-00 <i>incl. Connector</i> Requires 7.25" Shaft: 530-5658-00
	▶▶▶ OPTIONAL ◀◀◀ Shaker	Multi #3811 0630 Motor (Vibrator) 12VDC (041-5029-01) 3100 RPM (w/DRL PTS)	515-5893-01 <i>incl. Connector</i>
The Sopranos™	Bada Bing! Girls x2 Rotating Posts Movement	Autotrol Synchronous Motor 24VAC 4W 50/60Hz 45.7/54.9 RPM Bi-Directional	041-5092-00 <i>w/1" Shaft + 12" Leads</i>
NASCAR® and [NDSE]	Back Panel Rotating (Car) Windmill (Skill Ball Enter)	Multi Products Motor & Gear Box 20VDC Model #8000 (EX-04-073) 10 RPM	041-5093-00 MOTOR ONLY
Grand Prix	Back Panel Rotating (Car) Windmill (Skill Ball Enter)	Multi Products Motor & Gear Box 20VDC Model #8000 (EX-04-073) 10 RPM	041-5093-00 MOTOR ONLY
World Poker Tour™ (WPT) (NO MOTOR USED)			
The Simpsons™ Kooky Carnival	Bart on Skateboard Left/Right Movement	Multi Products Motor with Crank 24VAC (041-5095-01) 50/60Hz 3W 14 RPM	500-6947-01 <i>incl. Connector</i>
	Left & Right Ramps Up/Down Movement	Multi Products Motor 24VAC (041-5048-01) 50/60Hz 3W 15 RPM CCW (Qty. 2 in game)	515-7558-00 <i>incl. Connector</i>
	Shaker <i>(details in SKC Manual, Page 24)</i>	Multi #3811 0630 Motor (Vibrator) 12VDC 3100 RPM (w/DRL PTS)	041-5029-01 MOTOR ONLY
©Disney's Pirates of the Caribbean	Spinning Disk	Multi #3811R 0630 Motor (Vibrator) 12VDC (041-5029-04) 3100 RPM (w/DRL PTS) -04 is RoHS compliant; can substitute with -01 domestic	511-5024-04 <i>incl. Connector</i>
	Pirate Ship Sinking/Raising Movement	Multi Products Motor & Gear Box 24VDC Model #7000-DCM 12 RPM	041-5101-00 MOTOR ONLY
Family Guy™	Stewie Figurine Left & Right Movement	Stepper Motor NPM PF35T-48D4STD 5V RVB (041-5102-00 Reference Only)	511-5043-00 <i>incl. Connector</i>
Spider-Man™	Doc Ock, Sandman & 3-Bank Up/Down Movement	Sync. Motor 24VAC 50/60Hz 3W 12 RPM CW (041-5103-00 Reference Only)	511-5063-00 <i>incl. Connector</i>
	▶▶▶ OPTIONAL ◀◀◀ Shaker Motor Kit 502-5027-00	Multi #3811R 0630 Motor (Vibrator) 12VDC (041-5029-04) 3100 RPM (w/DRL PTS) -04 is RoHS compliant; can substitute with -01 domestic	515-5893-01 <i>incl. Connector</i>



APPENDIX F

Motor Specification Table

The following table only list games that used motors. Part Numbers starting with "515-" will include the Wiring Harness & Connector.

Game Name	Function	Specifications	Part N ^o
ABC Monday Night Football	Goal Post Up/Down Movement	Motor 24v A.C. 60 RPM CW	515-5222-00
Phantom of the Opera	Organ Up/Down Movement	Bowman Motor 24v 60Hz 3W 11 RPM CCW	515-5256-00
Checkpoint	Mag Wheel (in Backbox)	Motor D.C. (KEN)	041-5005-00
	Shaker	Johnson Motor (Vibrator)	041-5002-00
Teenage Mutant Ninja Turtles	Spinning Pizza Ball Deflector	Gear Motor 24v A.C. 325 RPM CW	515-5397-00
Batman	Bar Target Up/Down Movement	Bowman Motor 24v 60Hz 3W 11 RPM CCW	515-5256-00
Star Trek 25th Anniversary	Swinging Target	Bowman Motor 24v 22½ RPM	515-5534-00
	Transporter F/X	Gear Motor 24v A.C. 3½ RPM	500-5421-00
	Cooling Fan (for Transporter F/X)	4½" Motor 12v	041-5014-00
Lethal Weapon 3	Spinning Light	Motor 2½ v A.C. 4000 RPM CCW	041-5017-00
Star Wars	Bar Target Up/Down Movement	Bowman Motor 24v 60hz 3W 11 RPM CCW	515-5256-00
	R2D2 Robot Left/Right Movement	Bowman Motor 24v A.C. 22½ RPM CW	515-5571-00
	Death Star Rotation	Bowman "G" Motor 24v A.C. 60Hz 6 RPM CW	515-5570-00
Rocky & Bullwinkle & Friends	Nell Log "Cutting Blade" Forward/Back Movement	Autotrol Model E Motor 24v 60hz 4W 3 RPM CCW	041-5023-00
Jurassic Park	T-Rex Left/Right Movement	Multi Motor 5v D.C.	041-5025-00
	T-Rex Up/Down Movement	Bowman Motor 24v 11 RPM CW	041-5026-00
	Shaker	Johnson Motor (Vibrator)	041-5002-00
Last Action Hero	Crane Left/Right Movement	Multi Products Motor 12v D.C. #3312 OSC	041-5027-00
	Shaker	Johnson Motor (Vibrator) 10.5v D.C. 10 AMP 2950 RPM CW	041-5029-00
Tales from the Crypt	Tombstone Up/Down Movement	Bowman Motor 24v A.C. 6 RPM CCW	515-5900-00
	Shaker	Johnson Motor (Vibrator) 10.5v D.C. 10 AMP 2950 RPM CW	041-5029-00
The Who's Tommy	Mirror Up/Down Movement	Bowman Motor 24v A.C. 6 RPM CCW	515-5900-00
	Flipper Blinders	Servo Motor (94102)	041-5032-00
	Spinning Airplane Propellers	Motor D.C.	041-5033-00
WWF Royal Rumble	Shaker	Johnson Motor (Vibrator) 10.5v D.C. 10 AMP 2950 RPM CW	041-5029-00
Maverick, The Movie	Turning Paddle Wheel	Motor 24v A.C. 10 RPM	041-5036-00
Mary Shelley's Frankenstein	Creature Head Left/Right Movement	Servo Motor (94102)	041-5032-00
Batman Forever	Cannon Left/Right Movement	Bowman Motor 24v A.C. 60Hz 3W 6 RPM CCW	515-6383-00

APPENDIX G

Part Number Prefix Classification Codes

I. Electrical Source, Energy & Signal Converters

- 010- Transformers
- 031- Speakers
- 090- Solenoids (Coils)
- 150- Filters, Outlets, Varistors, Thermistors
- 200- Fuses

II. Conductors, Connectors & Insulators

- 034- Line Cords
- 036- Cable Assemblies & Wiring Harnesses
- 041- Motors
- 045- Connectors (All Types)
- 055- Lugs (M/F), Pins (M/F), Discs, Ring Terminals, Terminal Strips, etc.
- 060- Polarizing Keys and Conn. Covers
- 077- Lamp Sockets

III. Circuits & Circuit Elements

- 100- ICs
- 110- Transistors
- 112- Diodes (All Types including LEDs & Modules)
- 121- Resistors
- 123- Resistors (Variable & Adjustable)
- 124- Regulators & Bridge Rectifiers
- 125- Capacitors (Radial Lytics & Ferrites)
- 126- Piezo Crystal
- 127- Heatsinks
- 130- Capacitors (Tectates & Ceramics)
- 140- Oscillators (Clocks/Crystals)
- 165- Light Bulbs
- 180- Switches
- 181- Switch Membranes (Pads) & Piezo Sensors
- 190- Relays
- 960- EPROM (*Raw Part*)
- 965- EPROM (*Programmed Part*)

IV. Bolts, Screws, Nuts, Washers & Nails

- 231- Bolts
- 232- Screws (Pan Head)
- 234- Screws (HWH)
- 237- Screws (Misc.)
- 240- Nuts (Misc.)
- 242- Washers (Flat, Round)
- 244- Washers (Split Lock)
- 245- Nyloners
- 246- Washers (Lockers, External Tooth)
- 281- Nails

V. Mechanical Components

- 249- Rivets
- 251- Pins (Dowel), Finishing Nails, Hairpins, Spring Pins and Clevis Pins
- 254- Stand-Offs, Spacers and Shims
- 260- Steel Ball (All Types Steel, Glowing, Delrin, etc.)
- 265- Springs (Extension)
- 266- Springs (Compression)
- 267- Springs (Torsion)
- 269- Springs (Washers - Belleville, Wave)
- 270- Retaining Rings
- 280- Grommets, Bushings and Nyloners
- 283- Bearings

VI. Handles, Locks, Catches, Latches, Keys

- 355- Handles, Locks, Catches, Latches and Keys

VII. Fabricated Parts

- 390- Hinges
- 501- Coin Doors
- 515- Sub-Assemblies
- 520- Printed Circuit Boards (PCBs)
- 522- Display Glass
- 525- Wood Parts
- 530- Screw Machined Parts
- 535- Fabricated Parts
- 545- Molded (Extruded) Plastic and Rubber Parts (Rings, Sleeves, etc.)
- 550- Molded (Inserts)

VIII. In-House Assemblies

- 500- End Product (Systems and Models)
 - 502- Kits (Created In-House)
 - 505- Cabinets (complete)
 - 510- Riveted Sub-Assemblies (In-House)
 - 511- Sub-Assemblies (In-House)
 - 515- Sub-Assemblies*
- *2 or more 515-'s but still a sub-assembly.

IX. Bulk Materials

- 600- Braided Wire & Ground Straps
- 601- Stranded Wire
- 602- Ribbon Cable
- 604- Telephone Line Cord
- 605- Sleeving (Shrink Tubing)
- 625- Velcro (non-adhesive)
- 626- Foam Rubber, Foam Pads, Rubber Bumpers (Blue Pads), Tape (All Types) Velcro (adhesive) and String / Rope

















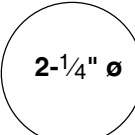
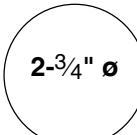



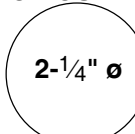
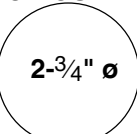

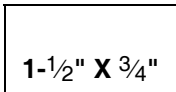
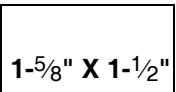
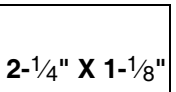
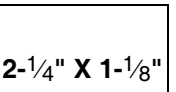
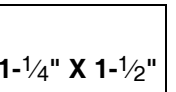
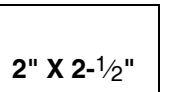

X. Miscellaneous

- 000- Tools (*see also 777-*) and Supplies
- 040- Clamps, Ties & Clips
- 042- Pulleys
- 091- Coin Mechs
- 205- Fuse Holders
- 631- Staples
- 660- Glass (Playfield, Backglass, etc.)
- 675- Cleaners
- 705- Packing & Shipping Items
- 755- Instruction, Coin Cards, Ins. Sheets
- 756- Information Sheets, Service Bulletins, Instruction Sheets in Kits and Templates
- 777- Tools (Wrenches and Drivers)
- 780- Manuals
- 802- Decal Kits (comprised of 820's)
- 820- Decals, Mylar and Labels (Sheets/Sets)
- 803- Plastic Kits (comprised of 830's)
- 830- Plastic Pieces (Butyrate Sheets/Sets)
- 880- Toys, Models, Figurines, etc.
- 900- Game Posters

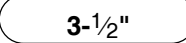
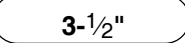

APPENDIX H

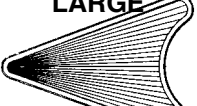
Playfield Inserts (Plastic Light Covers)

Patterns: STARBURST  STIPPLE 	STARBURST CIRCULAR  550-5000-XX	STARBURST CIRCULAR  550-5001-XX	STARBURST CIRCULAR  550-5002-XX	STARBURST CIRCULAR  550-5003-XX	STARBURST CIRCULAR  550-5004-XX
STARBURST CIRCULAR  550-5005-XX	STARBURST CIRCULAR  550-5006-XX	PLAIN CIRCULAR  550-5007-XX	PLAIN CIRCULAR  550-5008-XX	PLAIN CIRCULAR  550-5009-XX	PLAIN CIRCULAR  550-5010-XX
PLAIN CIRCULAR  550-5011-XX	PLAIN CIRCULAR  550-5012-XX	STIPPLE CIRCULAR  550-5048-XX	STIPPLE 1" SQUARE  550-5019-XX	ROLLOVER BUTTON BASE  550-5026-XX	WHITE STAR (only in white)  545-5015-00
STIPPLE RECTANGULAR  550-5018-XX	STIPPLE RECTANGULAR  550-5051-XX	STARBURST RECTANGULAR  550-5044-XX	PLAIN RECTANGULAR  550-5049-XX	PLAIN RECTANGULAR  550-5050-XX	PLAIN RECTANGULAR  550-5063-XX
STARBURST MINI SHIELD  550-5024-XX	STARBURST LARGE SHIELD  550-5025-XX	MINI HOT DOG  550-5020-XX	BEVEL HOT DOG  550-5021-XX	PLAIN HOT DOG  550-5022-XX	BANANA  550-5023-XX
STARBURST ARROW-SMALL  550-5013-XX	STARBURST ARROW-LARGE  550-5070-XX	STARBURST ARROW-HEAD SMALL  550-5014-XX	STARBURST ARROW-HEAD LARGE  550-5015-XX	STARBURST BULLET  550-5016-XX	STARBURST TRIANGLE  550-5017-XX

Note: The shapes and sizes shown above are not to scale. Some shapes may no longer be available in every color.

Instructions: Parts which may come in various colors (i.e. targets, some posts, playfield inserts, etc.) end in a 2-digit number which correspond to the color of that part. The "-XX" in part number which may come in various colors should be replaced with the desired 2-Digit number corresponding to the color desired below. *Not all colors may be available.*

PLASTIC PART COLOR CHART											
Nº	Color	Nº	Color	Nº	Color	Nº	Color	Nº	Color	Nº	Color
-00	Black or Solid Clear	-03	Amber	-06	Yellow	-09	Purple	-12	Fluor. Blue	-15	Luminescent
-01	Clear	-04	Green	-07	Orange	-10	Fluor. Orange	-13	Teal Green	-16	Gold
-02	Red	-05	Blue	-08	White	-11	Fluor. Green	-14	Gray	-17	Trans. Brown

APPENDIX I

Stand-Up Targets

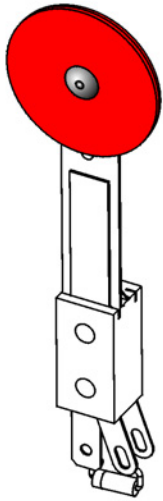

112-5003-00
Switch Diode, 1N4004
(all Stand-Up Targets)

515-5966-XX
1" ROUND STAND-UP
SWITCH & TARGET
RIVETED ASSEMBLY*

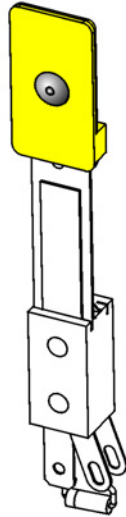

515-5967-XX or 515-7581-XX
STANDARD ANTI-LOFT
1" X 1/2" NARROW STAND-UP
SWITCH & TARGET
RIVETED ASSEMBLY*

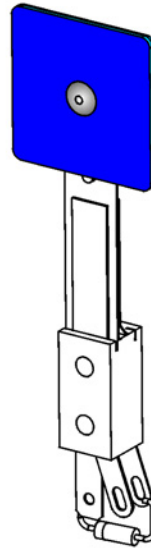

515-5162-XX
1" X 1" SQUARE STAND-UP
SWITCH & TARGET
RIVETED ASSEMBLY*

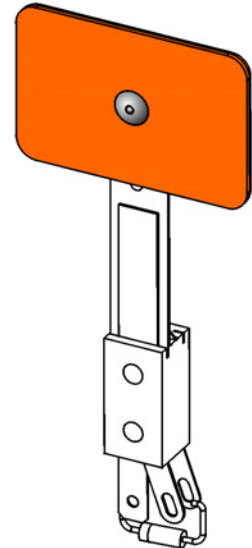

515-6027-XX
1" X 1-1/2" RECTANGLE STAND-UP
SWITCH & TARGET
RIVETED ASSEMBLY*

**Note: Does not include the Switch Back Plate, Mounting Bracket or screws.*

To include the Switch Back Plate, Foam Pad, and Switch Mounting Bracket assembled, use the follow assembly part numbers (replace the -XX with 2-digit number from chart):

500-5835-XX : 1" ROUND TARGET 500-5857-XX : 1" X 1/2" NARROW TARGET 500-5232-XX : 1" X 1" SQUARE TARGET 500-5321-XX : 1" X 1-1/2" RECT. TARGET

REAR VIEW 515-5967-06 SHOWN

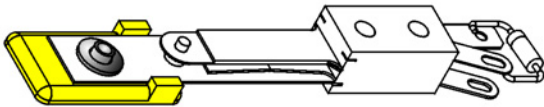

SHOWN BELOW : 500-5857-06
1" X 1/2" NARROW STAND-UP
TARGET ASSEMBLY COMPLETE

626-5029-00
Foam Pad, Square
.44" X .44" X .125" Thick (Self-Adhesive)**

** Note:
Use with all Switch
& Targets THIS page
except for 515-7581-XX

535-6896-00
Bracket, Switch
Mounting
(all targets THIS page)

237-5976-05
#6-32 X 3/4" SHWH Sc.
(all targets THIS page)

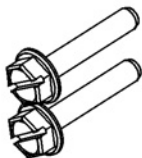

515-5967-XX
1" X 1/2" NARROW
STAND-UP (STANDARD)
SWITCH & TARGET
RIVETED ASSEMBLY*

535-6452-00
Switch Back Plate**

535-6896-00
Bracket, Switch
Mounting
(all targets THIS page)

237-5976-05
#6-32 X 3/4" SHWH Sc.
(all targets THIS page)

-XX REPLACE WITH 2-DIGIT FOR COLOR:

- 00 Black
- 01 Clear
- 02 Red
- 03 Amber
- 04 Green
- 05 Blue
- 06 Yellow
- 07 Orange
- 08 White
- 09 Purple
- 10 Fluor. Orange
- 11 Fluor. Green
- 12 Fluor. Blue
- 13 Teal Green
- 14 Gray
- 15 Luminescent
- 16 Gold

Note: Not all colors available.

SHOWN BELOW : 500-6985-04

1" X 1/2" NARROW ANTI-LOFT
STAND-UP TARGET
ASSEMBLY COMPLETE

626-5069-00
Foam Pad, Rectangle
.6" X .4" X .25" Thick (Self-Adhesive) ‡

535-9823-01
Switch Back
Plate ‡

‡ Note: Use only with
515-7581-XX Switch &
Target Assembly unless
otherwise noted.

515-7581-XX
1" X 1/2" NARROW
STAND-UP TALL
SWITCH & TARGET
RIVETED ASSEMBLY*

ORDERING NOTE: 515-7581-XX (500-6985-XX)
differences from 515-5967-XX (500-5857-XX) are:

1. Switch & Target Taller (Target sits higher over P/F)
2. Switch Back Plate differs (bend, shape & tab)
3. Foam Pad differs (thicker, taller, different type foam)

**Note: Does not include the Switch Back Plate, Mounting Bracket or screws.*

APPENDIX I

Modular Stand-Up Targets

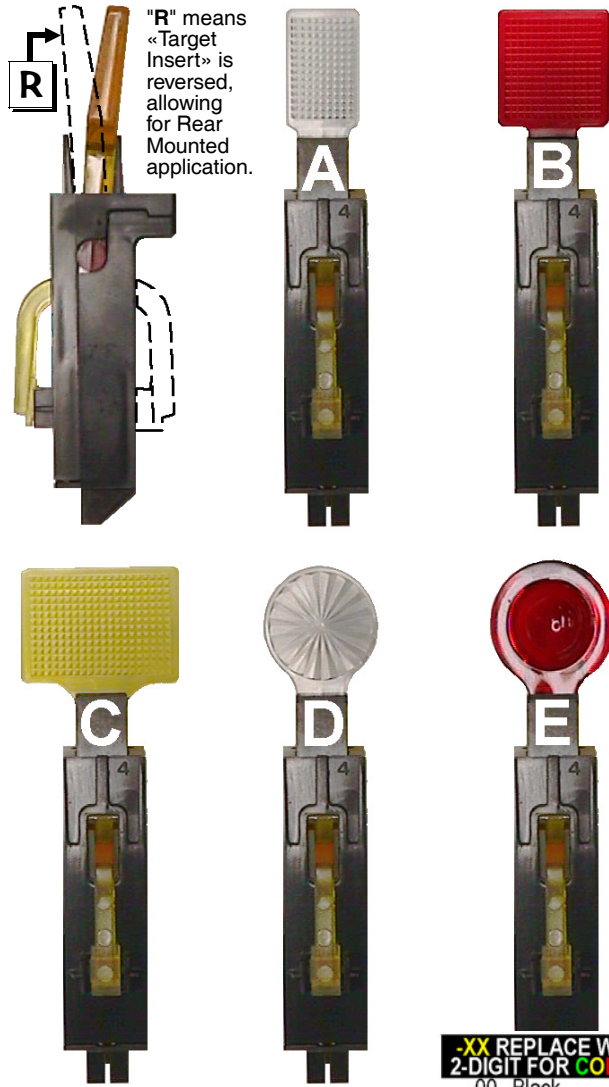

"R" means «Target Insert» is reversed, allowing for Rear Mounted application.

To Replace the « Target Insert » or change Target Orientation :

Items A-E Note: For the Target Assembly use the "500-" SPI Part Number(s) shown in the Parts Table below. To receive the Target Assembly with the « Target Insert » « Reversed » simply add a "R" at the end of the Part Number. See Side View picture left to compare (dashed line shows target reversed). For just the «Target Insert» use the "545-" SPI Part Number.



To reverse it yourself or to just change the insert:

1. With a small flat head screwdriver, push into the small tab at the bottom of the target front and give a slight twist motion to "pop" the two halves.

2. Push the Target Insert bottom in at the same time while you slide the top (front) part up, then let go of the insert as the two halves come apart.

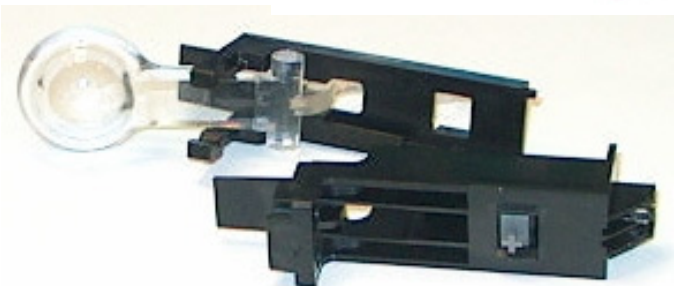
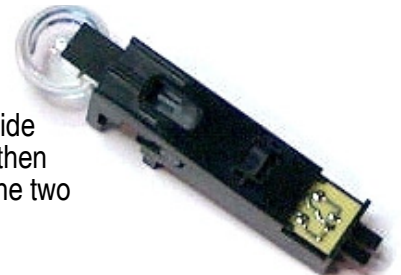

3. Replace target or reinsert it into the other size while sliding the two halves back together.

Note: If you were reversing the orientation, don't forget to also turn the Switch Actuator PCB 180°. Test Switch.

Take Note:

- Items A-E come in various colors. These targets may not be available in every color. The "-XX" in should be replaced with the desired 2-Digit number for the color desired as described in the Color Chart below. As of print date, the following colors were used :
 -01 Clear (A, D); -02 Red (A, B, C, D, E); -03 Amber (D, E);
 -04 Green (A, B); -05 Blue (C); -06 Yellow (A, C),
 -09 Purple (B, D); -11 Fluorescent Green (A, B, D)
- For location(s) and type of Stand-Up Targets used, if any, see Section 4, Chapter 1, Parts Identification & Location.

XX REPLACE WITH 2-DIGIT FOR COLOR:

- 00 Black
 - 01 Clear
 - 02 Red
 - 03 Amber
 - 04 Green
 - 05 Blue
 - 06 Yellow
 - 07 Orange
 - 08 White
 - 09 Purple
 - 10 Fluor. Orange
 - 11 Fluor. Green
 - 12 Fluor. Blue
 - 13 Teal Green
 - 14 Gray
 - 15 Luminescent
 - 16 Gold
- Note: Not all colors available.

Nr.	STAND-UP TARGET PARTS	SPI PART Nr.
A	Modular Stand-Up Target Narrow Assy.	500-6138-XX
	Stand-Up Target Narrow (Insert)	545-6138-XX
B	Modular Stand-Up Target Square Assy.	500-6139-XX
	Stand-Up Target Square (Insert)	545-6139-XX
C	Modular Stand-Up Target Rectangle Assy.	500-6228-XX
	Stand-Up Target Rectangle (Insert)	545-6228-XX
D	Modular Stand-Up Target Round Assy.	500-6075-XX
	Stand-Up Target Round (Insert)	545-6075-XX
E	Mod. Stand-Up Target 1" Spherical Assy.	500-6189-XX
	Stand-Up Target 1" Spherical (Insert)	545-6189-XX

APPENDIX J



Coin Cards (USA & International Pricing Defaults) ▶ For Yellow Stock add -Y to the Part Number

If more than one Pricing Scheme is available for countries listed, the **F.** listed beside the option, denotes the Factory Default Setting.

FOR VIEWS OF THE LATEST or OPTIONAL USA, INTERNATIONAL / EURO AND CUSTOM COIN CARDS, VISIT OUR WEBSITE.

Not Shown USA 755-5400-10 Tournament Option \$2 = X1; 755-5400-11 Tournament Option \$1.50 = X1

USA 10 F. NON-TOURNAMENT PLAY \$.75 = x1 \$2.00 = x3 TOURNAMENT PLAY! \$1.50 = x1		USA 10 75¢ = x1 SUPER VALUE \$2.00 = x3		USA 2-7 or CANADA 50¢ = x1		FOR CUSTOM PRICING † Backside is Blank (Border Only) Typeset your Custom Pricing		USA 3 with ToPS™ NON-TOURNAMENT PLAY \$.50 = x1 \$1.00 = x2 TOURNAMENT PLAY! \$1.00 = x1		USA 5 with ToPS™ NON-TOURNAMENT PLAY \$.50 = x1 \$2.00 = x5 TOURNAMENT PLAY! \$1.00 = x1	
755-5400-11 Front		755-5400-11 Back		755-5400-02 Front		755-5400-01, -02 or -04 Back		755-5400-03 or -09 Front		755-5400-03 Back / -08 Front	
AUSTRALIA 1 F. \$1.00 = x1 SUPER VALUE \$2.00 = x3		AUSTRALIA 2 \$1.00 = x1		CROATIA 3 KUNA = x1 5 KUNA = x2		FOR CUSTOM PRICING † Backside is Blank (Border Only) Typeset your Custom Pricing		DENMARK 1 F. Kr. 3,00 = x1 Kr. 5,00 = x2		DENMARK 2 Kr. 2,00 = x1 Kr. 5,00 = x3 Kr. 10,00 = x7	
755-5406-00 Front		755-5406-00 Back		755-5410-00 Front		755-5410-00 Back		755-5402-00 Front		755-5402-00 Back	
JAPAN 1 ¥100 = x1		JAPAN 2 F. ¥100 = x1 ¥200 = x3		MIDDLE EAST (TOKEN) = x1		ANY COUNTRY CAN USE (COIN) = x1		NEW ZEALAND 1 F. \$1.00 = x1		NEW ZEALAND 2 \$1.00 = x1 SUPER VALUE \$2.00 = x3	
755-5408-01 Front		755-5408-01 Back		755-5400-06 Front		755-5400-06 Back		755-5406-00 Back		755-5406-00 Front	
NORWAY 1 F. Kr. 10,00 = x1		NORWAY 2 Kr. 10,00 = x1 Kr. 20,00 = x3		RUSSIA F. 5 Рублей = x1		RUSSIA (ALTERNATE) (КЕРОН) = x1		SOUTH AFRICA R2 = x1		FOR CUSTOM PRICING † Backside is Blank (Border Only) Typeset your Custom Pricing	
755-5403-01 Front		755-5403-01 Back		755-5411-00 Front		755-5411-00 Back		755-5409-01 Front		755-5409-01 Back	
SWEDEN 1 F. 10,00 kr. = x1 15,00 kr. = x2 20,00 kr. = x3		SWEDEN 2 5,00 kr. = x1		SWITZERLAND 1 F. sf 1,00 = x1 sf 5,00 = x6		SWITZERLAND 2 sf 1,00 = x1 sf 2,00 = x3 sf 5,00 = x9		TAIWAN TWD10 = x1		FOR CUSTOM PRICING † Backside is Blank (Border Only) Typeset your Custom Pricing	
755-5404-00 Front		755-5404-00 Back		755-5405-00 Front		755-5405-00 Back		755-5412-00 Front		755-5412-00 Back	
UK 1 £1.00 = x3 £2.00 = x7		UK 3 £ .50 = x1 £1.00 = x2 £2.00 = x5		UK 5 F. £1.00 = x1 £2.00 = x3		FOR CUSTOM PRICING † Backside is Blank (Border Only) Typeset your Custom Pricing		Appendix J Notes: 1. Coin Card on Game is determined by original shipping country destination. 2. Optional Coin Card(s), are available via your distributor or via free download @ www.sterpinball.com/coinagecards.shtml . Older style Coin Cards (foreign or domestic) not available on our website or no longer available through your distributor, are obsolete. 3. Coin Cards which have a Blank Backside can be used for †Custom Pricing.			
755-5407-00 Front		755-5407-00 Back		755-5407-01 Front		755-5407-01 Back					

Not Shown EURO 755-5401-20 Tournament Custom (can fill in your own pricing).

EURO 1 € .50 = x1		EURO 2 € .50 = x1 €1.00 = x2 €2.00 = x5		EURO 3 € .50 = x1 €1.00 = x3		EURO 4 € .50 = x1 €1.00 = x2 €2.00 = x6		EURO 5 € .50 = x1 €1.00 = x3 €2.00 = x7		EURO 6 € .50 = x2	
755-5401-01 1-Side Only		755-5401-02 1-Side Only		755-5401-03 1-Side Only		755-5401-04 1-Side Only		755-5401-05 1-Side Only		755-5401-06 1-Side Only	
EURO 7 €1.00 = x1 €4.00 = x5		EURO 8 €1.00 = x1 €2.00 = x3		EURO 9 €1.00 = x1 €1.50 = x2 €2.00 = x3		EURO 10 €1.00 = x1 €2.00 = x3 €3.00 = x7		EURO 11 €1.00 = x1 €2.00 = x4		EURO 12 €1.00 = x2 €4.00 = x9	
755-5401-07 1-Side Only		755-5401-08 1-Side Only		755-5401-09 1-Side Only		755-5401-10 1-Side Only		755-5401-11 1-Side Only		755-5401-12 1-Side Only	

▶ EURO FACTORY DEFAULT SUMMARY TABLE ◀

EURO 1	EURO 2	EURO 3	EURO 4	EURO 5	EURO 6	EURO 7	EURO 8	EURO 9	EURO 10	EURO 11	EURO 12
BELGIUM ITALY 1 PORTUGAL	GERMANY 2	NETHERLANDS SPAIN			GREECE		FINLAND	AUSTRIA	FRANCE		

Section 3, Chapter 4, GO TO ADJUSTMENTS MENU, Adj. 18, Game Pricing, USA & International (non-Euro) and Euro 1-12 Summary & International (Euro) Standard Pricing Select Tables, summarizes Standard or Custom Pricing Schemes & the Dip Switch Setting required.





APPENDIX A



Pinball Game Firmware (White Star Board System* Only) Table

See website for the latest International Code or Updated USA version / checksums

ROM	Chip Size	Program Part N ^o	USA ver. & Check Sum	Bd. Loc.	Raw Part N ^o
Apollo 13 (Note 1)					
Game ROM (1M)	965-0208-00	A5.01	\$09FF	U210	960-5009-00
Sound (512K)	965-0212-00	1.00	\$5244	U7	960-7001-02
Display (4M)	965-0213-00	A5.00	\$B92B	ROM 0	960-5015-01
Voice 1 (4M)	965-0209-00	1.00	\$7FC7	U17	n/a (masked)
Voice 2 (4M)	965-0210-00	1.00	\$8E55	U21	n/a (masked)
Voice 3 (4M)	965-0211-00	1.00	\$08EE	U36	n/a (masked)
Golden Eye (Note 1)					
Game ROM (1M)	965-0214-42	A4.04	\$3FFF	U210	960-5009-00
Sound (512K)	965-0217-42	1.00	\$D615	U7	960-7001-02
Display (4M)	965-0218-42	A4.00	\$E6ED	ROM 0	960-5015-01
Voice 1 (4M)	965-0215-42	1.00	\$3E32	U17	n/a (masked)
Voice 2 (4M)	965-0216-42	1.00	\$71F0	U21	n/a (masked)
Twister (Note 2)					
Game ROM (1M)	965-0219-41	A4.05	\$E9FF	U210	960-5009-00
Sound (512K)	965-0221-41	1.00	\$1FFF	U7	960-7001-02
Display (4M)	965-0222-41	A4.00	\$FD01	ROM 0	960-5015-01
Voice 1 (4M)	965-0220-41	1.00	\$3650	U17	960-5015-01
Voice 2 (4M)	965-0223-41	1.00	\$9300	U21	960-5015-01
ID4: Independence Day (Note 2)					
Game ROM (1M)	965-0224-45	A2.02	\$9CFF	U210	960-5009-00
Sound (512K)	965-0227-45	1.00	\$222B	U7	960-7001-02
Display (4M)	965-0228-45	A2.00	\$AB77	ROM 0	960-5015-01
Voice 1 (4M)	965-0225-45	1.00	\$3F41	U17	960-5015-01
Voice 2 (4M)	965-0226-45	1.00	\$206E	U21	960-5015-01
Space Jam (Note 2)					
Game ROM (1M)	965-0229-43	A3.00	\$E6FF	U210	960-5009-00
Sound (512K)	965-0233-43	1.00	\$F1E7	U7	960-7001-02
Display (4M)	965-0230-43	A3.00	\$0057	ROM 0	960-5015-01
Voice 1 (4M)	965-0234-43	1.00	\$D8A8	U17	960-5015-01
Voice 2 (4M)	965-0231-43	1.00	\$DDF1	U21	960-5015-01
Voice 3 (4M)	965-0232-43	1.00	\$F32A	U36	960-5015-01
The Star Wars Trilogy - Special Edition (S.E.) (Note 2)					
Game ROM (1M)	965-0235-56	A4.03	\$5EFF	U210	960-5009-00
Sound (512K)	965-0238-56	1.00	\$4A7D	U7	960-7001-02
Display (4M)	965-0239-56	A4.00	\$8817	ROM 0	960-5015-01
Voice 1 (4M)	965-0236-56	1.00	\$E66B	U17	960-5015-01
Voice 2 (4M)	965-0237-56	1.00	\$8F54	U21	960-5015-01
The Lost World: Jurassic Park (Note 2)					
Game ROM (1M)	965-0240-53	A2.02	\$C8FF	U210	960-5009-00
Sound (512K)	965-0243-53	1.00	\$A35B	U7	960-7001-02
Display (4M)	965-0244-53	A2.01	\$7F46	ROM 0	960-5015-01
Voice 1 (4M)	965-0241-53	1.00	\$1D27	U17	960-5015-01
Voice 2 (4M)	965-0242-53	1.00	\$8DA4	U21	960-5015-01
The X-Files (Note 2)					
Game ROM (1M)	965-0245-46	A3.03	\$A2FF	U210	960-5009-00
Sound (512K)	965-0248-46	1.00	\$65A8	U7	960-7001-02
Display (4M)	965-0249-46	A3.00	\$66D0	ROM 0	960-5015-01
Voice 1 (4M)	965-0246-46	1.00	\$349D	U17	960-5015-01
Voice 2 (4M)	965-0247-46	1.00	\$629C	U21	960-5015-01
Starship Troopers (Note 3)					
Game ROM (1M)	965-0250-59	A2.00	\$85FF	U210	960-5009-00
Sound (512K)	965-0253-59	1.00	\$64B2	U7	960-7001-02
Display (4M)	965-0254-59	A2.00	\$E77B	ROM 0	960-5015-01
Voice 1 (4M)	965-0251-59	1.00	\$152A	U17	960-5015-01
Voice 2 (4M)	965-0252-59	1.00	\$0291	U21	960-5015-01
Voice 3 (4M)	965-0255-59	1.00	\$95A7	U36	960-5015-01
Viper Night Drivin' (Note 4)					
Game ROM (1M)	965-0266-35	A2.01	\$C5FF	U210	960-5009-00
Sound (512K)	965-0271-35	1.00	\$4DF8	U7	960-7001-02
Display (4M)	965-0272-35	A2.01	\$C17D	ROM 0	960-5015-01
Voice 1 (4M)	965-0267-35	1.00	\$9018	U17	960-5015-01
Voice 2 (4M)	965-0268-35	1.00	\$2157	U21	960-5015-01
Voice 3 (4M)	965-0269-35	1.00	\$B5A6	U36	960-5015-01
Voice 4 (4M)	965-0270-35	1.00	\$D01E	U37	960-5015-01
Lost In Space (Note 4)					
Game ROM (1M)	965-0282-60	A1.01	\$B2FF	U210	960-5009-00
Sound (512K)	965-0287-60	1.00	\$A6AF	U7	960-7001-02
Display (4M)	965-0288-60	A1.02	\$32AB	ROM 0	960-5015-01
Voice 1 (4M)	965-0283-60	1.00	\$4391	U17	960-5015-01
Voice 2 (4M)	965-0284-60	1.00	\$8215	U21	960-5015-01
Voice 3 (4M)	965-0285-60	1.00	\$5B32	U36	960-5015-01
Voice 4 (4M)	965-0286-60	1.00	\$8971	U37	960-5015-01
Godzilla (Note 4)					
Game ROM (1M)	965-0289-40	A2.05	\$B1FF	U210	960-5009-00
Sound (512K)	965-0294-40	1.00	\$0CC9	U7	960-7001-02
Display (4M)	965-0290-40	A2.00	\$C929	ROM 0	960-5015-01
Voice 1 (4M)	965-0290-40	1.00	\$0D75	U17	960-5015-01
Voice 2 (4M)	965-0291-40	1.00	\$CCCF	U21	960-5015-01
Voice 3 (4M)	965-0292-40	1.00	\$227F	U36	960-5015-01
Voice 4 (4M)	965-0293-40	1.00	\$DB69	U37	960-5015-01
South Park (Notes 4, 5)					
Game ROM (1M)	965-0301-71	A1.03	\$58FF	U210	960-5009-00
Sound (512K)	965-0306-71	1.00	\$1286	U7	960-7001-02
Display (4M)	965-0307-71	A1.01	\$166F	ROM 0	960-5015-01
Voice 1 (8M)	965-0302-71	1.00	\$7BF8	U17	960-5016-00
Voice 2 (8M)	965-0303-71	1.00	\$9CC0	U21	960-5016-00
Voice 3 (8M)	965-0304-71	1.00	\$ADD9	U36	960-5016-00
Voice 4 (8M)	965-0305-71	1.00	\$6559	U37	960-5016-00

ROM	Chip Size	Program Part N ^o	USA ver. & Check Sum	Bd. Loc.	Raw Part N ^o
Harley-Davidson® (Notes 4, 5, 6) Original (1999-2001)					
Game ROM (1M)	965-0319-67	A1.03	\$3EFF	U210	960-5009-00
Sound (512K)	965-0320-67	1.00	\$F4FF	U7	960-7001-02
Display (4M)	965-0321-67	A1.04	\$FC7C	ROM 0	960-5015-01
Voice 1 (8M)	965-0322-67	1.00	\$CD26	U17	960-5016-00
Voice 2 (8M)	965-0323-67	1.00	\$3936	U21	960-5016-00
Voice 3 (8M)	965-0324-67	1.00	\$FB72	U36	960-5016-00
Voice 4 (4M)	965-0325-67	1.00	\$6100	U37	960-5015-01
► Harley-Davidson® (Notes 4, 5, 6, 8) 2nd Edition (2002-2003)					
Game ROM (1M)	965-0319-67A	A1.08	\$23FF	U210	960-5009-00
Display (4M)	965-0321-67A	A1.05	\$B594	ROM 0	960-5015-01
► Harley-Davidson® (Notes 4, 5, 6, 8) 3rd Edition (2004)					
Game ROM (1M)	965-0319-87	A4.00	\$1CFF	U210	960-5009-00
Display (4M)	965-0321-87	A4.00	\$F4FF	U5	960-5015-01
Striker Xtreme (Notes 4, 5)					
Game ROM (1M)	965-0326-68	A1.03	\$E4FF	U210	960-5009-00
Sound (512K)	965-0327-68	1.00	\$3BCA	U7	960-7001-02
Display (4M)	965-0328-68	A1.03	\$1957	ROM 0	960-5015-01
Voice 1 (8M)	965-0329-68	1.00	\$482A	U17	960-5016-00
Voice 2 (8M)	965-0330-68	1.00	\$7312	U21	960-5016-00
Voice 3 (8M)	965-0331-68	1.00	\$DE2F	U36	960-5016-00
Voice 4 (8M)	965-0332-68	1.00	\$C508	U37	960-5016-00
NFL (Notes 4, 5) Not on CD-R or Website: Code through Distributor Only.					
Game ROM (1M)	965-0339-73	A1.00	\$D2FF	U210	960-5009-00
Sound (512K)	965-0340-73	1.00	U7	960-7001-02	
Display (4M)	965-0341-73	A1.01	\$845A	ROM 0	960-5015-01
Voice 1 (8M)	965-0342-73	1.00	U17	960-5016-00	
Voice 2 (8M)	965-0343-73	1.00	U21	960-5016-00	
Voice 3 (8M)	965-0344-73	1.00	U36	960-5016-00	
Voice 4 (8M)	965-0345-73	1.00	U37	960-5016-00	
Sharkey's Shootout (Notes 4, 5)					
Game ROM (1M)	965-0333-72	A2.11	\$49FF	U210	960-5009-00
Sound (512K)	965-0333-72	1.01	\$9796	U7	960-7001-02
Display (4M)	965-0335-72	A2.01	\$6C33	ROM 0	960-5015-01
Voice 1 (8M)	965-0336-72	1.00	\$58EA	U17	960-5016-00
Voice 2 (8M)	965-0337-72	1.00	\$272B	U21	960-5016-00
Voice 3 (8M)	965-0338-72	1.00	\$41AE	U36	960-5016-00
High Roller Casino (Notes 4, 5)					
Game ROM (1M)	965-0346-65	A3.00	\$90FF	U210	960-5009-00
Sound (512K)	965-0347-65	1.00	\$581C	U7	960-7001-02
Display (4M)	965-0348-65	A3.00	\$74B3	ROM 0	960-5015-01
Voice 1 (8M)	965-0349-65	1.00	\$E12D	U17	960-5016-00
Voice 2 (8M)	965-0350-65	1.00	\$38F4	U21	960-5016-00
Voice 3 (8M)	965-0351-65	1.00	\$1B54	U36	960-5016-00
Voice 4 (8M)	965-0352-65	1.00	\$D720	U37	960-5016-00
Austin Powers™ (Notes 4, 5)					
Game ROM (1M)	965-0353-74	A3.02	\$5DFF	U210	960-5009-00
Sound (512K)	965-0354-74	1.00	\$D47B	U7	960-7001-02
Display (4M)	965-0355-74	A3.00	\$6A3A	ROM 0	960-5015-01
Voice 1 (8M)	965-0356-74	1.00	\$D2B9	U17	960-5016-00
Voice 2 (8M)	965-0357-74	1.00	\$9E75	U21	960-5016-00
Voice 3 (8M)	965-0358-74	1.00	\$51F3	U36	960-5016-00
Voice 4 (8M)	965-0359-74	1.00	\$0AE5	U37	960-5016-00
MONOPOLY® (Notes 4, 5)					
Game ROM (1M)	965-0360-75	A3.20	\$07FF	U210	960-5009-00
Sound (512K)	965-0361-75	1.00	\$8C18	U7	960-7001-02
Display (4M)	965-0362-75	A3.01	\$A381	ROM 0	960-5015-01
Voice 1 (8M)	965-0363-75	1.00	\$35E6	U17	960-5016-00
Voice 2 (8M)	965-0364-75	1.00	\$B35A	U21	960-5016-00
Voice 3 (8M)	965-0365-75	1.00	\$8A9F	U36	960-5016-00
Playboy (Notes 4, 5, 7)					
Game ROM (1M)	965-0367-76	A5.00	\$7DFF	U210	960-5009-00
Sound (512K)	965-0368-76	1.02	\$E7C2	U7	960-7001-02
Display (4M)	965-0369-76	A5.00	\$A5FF	ROM 0	960-5015-01
Voice 1 (8M)	965-0370-76	1.00	\$9A6E	U17	960-5016-00
Voice 2 (8M)	965-0371-76	1.00	\$9F34	U21	960-5016-00
Voice 3 (8M)	965-0372-76	1.00	\$374B	U36	960-5016-00
Voice 4 (8M)	965-0373-76	1.00	\$237A	U37	960-5016-00
RollerCoaster Tycoon™ (Notes 4, 5, 7)					
Sound (512K)	965-0374-78	1.00	\$F663	U7	960-7001-02
Game ROM (1M)	965-0375-78	A7.02	\$E5FF	U210	960-5009-00
Voice 1 (8M)	965-0377-78	1.00	\$3C4A	U17	960-5016-00
Voice 2 (8M)	965-0378-78	1.00	\$057A	U21	960-5016-00
Voice 3 (8M)	965-0379-78				



APPENDIX A

Pinball Game Firmware (White Star Board System* & S.A.M. System** Only) Table



See website for the latest International Code or Updated USA version / checksums

ROM	Chip Size	Program Part N°	USA Ver. & Check Sum	Bd. Loc.	Raw Part N°
Ripley's Believe It or Not!® (Notes 7, 8)					
Sound	(512K)	965-0408-81	1.00 \$D93D	U7	960-7001-02
Game ROM	(1M)	965-0409-81	A3.20 \$43FF	U210	960-5009-00
Voice 1	(8M)	965-0410-81	1.00 \$067B	U17	960-5016-00
Voice 2	(8M)	965-0411-81	1.00 \$C8B8	U21	960-5016-00
Voice 3	(8M)	965-0412-81	1.00 \$64C2	U36	960-5016-00
Voice 4	(8M)	965-0413-81	1.00 \$5341	U37	960-5016-00
Display	(4M)	965-0414-81	A3.00 \$DE4B	U5 DC PCB	960-5015-01

Elvis® (Notes 7, 8)					
Sound	(512K)	965-0415-84	1.00 \$8CD2	U7	960-7001-02
Game ROM	(1M)	965-0416-84	A5.00 \$50FF	U210	960-5009-00
Voice 1	(8M)	965-0417-84	1.00 \$538D	U17	960-5016-00
Voice 2	(8M)	965-0418-84	1.00 \$8BCD	U21	960-5016-00
Voice 3	(8M)	965-0419-84	1.00 \$60F8	U36	960-5016-00
Voice 4	(8M)	965-0420-84	1.00 \$14D8	U37	960-5016-00
Display	(4M)	965-0421-84	A5.00 \$A1F6	U5 DC PCB	960-5015-01

The SopranosSM (Notes 7, 8)					
Sound	(512K)	965-0422-85	4.00 \$9B5A	U7	960-7001-02
Game ROM	(1M)	965-0423-85	A5.00 \$5BFF	U210	960-5009-00
Voice 1	(8M)	965-0424-85	3.00 \$F01E	U17	960-5016-00
Voice 2	(8M)	965-0425-85	1.04 \$C14C	U21	960-5016-00
Voice 3	(8M)	965-0426-85	1.04 \$47A3	U36	960-5016-00
Voice 4	(8M)	965-0427-85	1.04 \$ADCD	U37	960-5016-00
Display	(4M)	965-0428-85	A5.00 \$B4BB	U5 DC PCB	960-5015-01

NASCAR® (Notes 7, 8)					
Sound	(512K)	965-0429-86	2.00 \$32B3	U7	960-7001-02
Game ROM	(1M)	965-0430-86	A4.50 \$39FF	U210	960-5009-00
Voice 1	(8M)	965-0431-86	2.00 \$CFFB	U17	960-5016-00
Voice 2	(8M)	965-0432-86	2.00 \$22C0	U21	960-5016-00
Voice 3	(8M)	965-0433-86	2.00 \$5FC8	U36	960-5016-00
Voice 4	(8M)	965-0434-86	2.00 \$2902	U37	960-5016-00
Display	(4M)	965-0435-86	A4.00 \$92BD	U5 DC PCB	960-5015-01

Grand Prix (Notes 7, 8)					
Sound	(512K)	965-0429-91	V1.00 \$6F89	U7	960-7001-02
Game ROM	(1M)	965-0430-91	A4.50 \$5EFF	U210	960-5009-00
Voice 1	(8M)	965-0431-91	1.00 \$C0E5	U17	960-5016-00
Voice 2	(8M)	965-0432-91	1.00 \$F4C6	U21	960-5016-00
Voice 3	(8M)	965-0433-91	1.00 \$057D	U36	960-5016-00
Voice 4	(8M)	965-0434-91	1.00 \$2646	U37	960-5016-00
Display	(4M)	965-0435-91	A4.00 \$DA8E	U5 DC PCB	960-5015-01

[NDSE] (Notes 7, 8) <i>Call for more info if code update required.</i>					
Sound	(512K)	965-0436-97		U7	960-7001-02
Game ROM	(1M)	965-0437-97		U210	960-5009-00
Voice 1	(8M)	965-0438-97		U17	960-5016-00
Voice 2	(8M)	965-0439-97		U21	960-5016-00
Voice 3	(8M)	965-0440-97		U36	960-5016-00
Voice 4	(8M)	965-0441-97		U37	960-5016-00
Display	(4M)	965-0442-97		U5 DC PCB	960-5015-01

**** GAMES BELOW THIS LINE / NEXT COLUMN ARE S.A.M. SYSTEM GAMES**

TO ORDER MEMORY STICK WITH GAME FILES FROM YOUR DISTRIBUTOR, USE SPI PART NUMBER 970-0128-00 & INCLUDE THE GAME NAME / LANGUAGE FILE(S) DESIRED.

World Poker Tour™ Pinball (WPT) (Notes 7, 9)					
Boot B-02	(8M)	965-BOOT-SAM	1.04 \$7E62	U9	960-5016-00 unprogrammed
Memory Stick 128MB (970-0128-00)		Version		System	Bin Files:
English + Spanish		1.12AL		1.17+	WPT0112AL.bin
English Only		1.12A		1.17+	WPT0112A.bin
English + French		1.12AF		1.17+	WPT0112AF.bin
French Only		1.12F		1.17+	WPT0112F.bin
German + French		1.12GF		1.17+	WPT0112GF.bin
German Only		1.12G		1.17+	WPT0112G.bin
English + Italian		1.12AI		1.17+	WPT0112AI.bin
Italian Only		1.12I		1.17+	WPT0112I.bin

NOTE: THE TYPICAL SIZE PER UNZIPPED BIN FILE IS 25MB – 30MB+/-

The Simpsons™ Kooky Carnival Redemption (Note 9)					
Boot B-02	(8M)	965-BOOT-SAM	1.04 \$7E62	U9	960-5016-00 unprogrammed
Memory Stick 128MB (970-0128-00)		Version		Bin Files:	
English Only		1.05		SKC0105.bin	
English New Jersey Only		0.09NJ		SKC0090NJ.bin	

NOTE: THE TYPICAL SIZE PER UNZIPPED BIN FILE IS 5.5MB +/-

©Disney's Pirates of the Caribbean Pinball (POTC) (Notes 7, 9)					
Boot B-02	(8M)	965-BOOT-SAM	1.06 \$2014	U9	960-5016-00 unprogrammed
Memory Stick 128MB (970-0128-00)		Version		System	Bin Files:
English + Spanish		1.15AS		1.17+	POTC115AS.bin
English + French		1.15AF		1.17+	POTC115AF.bin
German + French		1.15GF		1.17+	POTC115GF.bin
English + Italian		1.15AI		1.17+	POTC115AI.bin

NOTE: THE TYPICAL SIZE PER UNZIPPED BIN FILE IS 25MB – 30MB+/-

Family Guy™ Pinball (FG) (Notes 7, 9)					
Boot B-02	(8M)	965-BOOT-SAM	2.09 \$10A3	U9	960-5016-00 unprogrammed
Memory Stick 128MB (970-0128-00)		Version		System	Bin Files:
English + Spanish		10.00AL		1.23+	FG1000AL.bin
English + French		10.00AF		1.23+	FG1000AF.bin
English + German		10.00AG		1.23+	FG1000GF.bin
English + Italian		10.00AI		1.23+	FG1000AI.bin

NOTE: THE TYPICAL SIZE PER UNZIPPED BIN FILE IS 25MB – 30MB+/-

Spider-Man™ Pinball (S-M) (Notes 7, 9)					
Boot B-02	(8M)	965-BOOT-SAM	2.10 \$F625	U9	960-5016-00 unprogrammed
Memory Stick 128MB (970-0128-00)		Version		System	Bin Files:
English + Spanish		1.3ES		1.27+	spd_1_30_es.bin
English + French		1.3EF		1.27+	spd_1_30_ef.bin
German + French		1.3GF		1.27+	spd_1_30_gf.bin
English + Italian		1.3EI		1.27+	spd_1_30_ei.bin

NOTE: THE TYPICAL SIZE PER UNZIPPED BIN FILE IS 25MB – 30MB+/-

footnotes:

- ROMs on CPU/Sound Bd.: 520-5136-00 (Stereo) & Display Cont. Bd.: 520-5055-01
- ROMs on CPU/Sound Bd.: 520-5136-10 (Mono) & Display Cont. Bd.: 520-5055-01
- ROMs on CPU/Sound Board: 520-5136-15* (Mono) (*FCC 11-97) & Display Controller Board: 520-5055-02* (*FCC 11-97)



APPENDIX A

Pinball Game Firmware Table

EPROM	Chip Size	Program Part N ^o	USA Ver.	Bd. Loc.	Raw Part N ^o
Laser War					
CPU	(256K)	965-0004-00	LWAR.C5	C5	960-5007-00
Sound (Old)	(256K)	965-0005-00		J5	960-5007-00
Sound (Old)	(256K)	965-0006-00		J6	960-5007-00
Sound (Old)	(256K)	965-0007-00		J7	960-5007-00
- OR -					
Sound	(256K)	965-0008-00		7F	960-5007-00
Sound 1	(512K)	965-0009-00		6F	960-7001-02
Sound 2	(512K)	965-0010-00		4F	960-7001-02
Secret Service					
CPU	(256K)	965-0011-00	A4-6	B5	960-5007-00
CPU	(256K)	965-0012-00	A4-6	C5	960-5007-00
Voice 1	(512K)	965-0014-00		6F	960-7001-02
Voice 2	(512K)	965-0015-00		4F	960-7001-02
Sound	(256K)	965-0013-00		7F	960-5007-00
Torpedo Alley					
CPU	(256K)	965-0016-00	A2-1	B5	960-5007-00
CPU	(256K)	965-0017-00	A2-1	C5	960-5007-00
Voice 1	(512K)	965-0019-00		6F	960-7001-02
Voice 2	(512K)	965-0020-00		4F	960-7001-02
Sound	(256K)	965-0018-00		7F	960-5007-00
Time Machine					
CPU	(128K)	965-0021-00	A2-4	B5	960-5006-00
CPU	(256K)	965-0022-00	A2-4	C5	960-5007-00
Voice 1	(512K)	965-0024-00		6F	960-7001-02
Voice 2	(512K)	965-0025-00		4F	960-7001-02
Sound	(256K)	965-0023-00		7F	960-5007-00
Playboy 35th Anniversary					
CPU	(256K)	965-0046-00	A2-4	B5	960-5007-00
CPU	(256K)	965-0047-00	A2-4	C5	960-5007-00
Voice 1	(512K)	965-0049-00		6F	960-7001-02
Voice 2	(512K)	965-0050-00		4F	960-7001-02
Sound	(256K)	965-0048-00		7F	960-5007-00
ABC Monday Night Football					
CPU	(128K)	965-0031-00	A2-7	B5	960-5006-00
CPU	(256K)	965-0032-00	A2-7	C5	960-5007-00
Voice 1	(512K)	965-0034-00		6F	960-7001-02
Voice 2	(512K)	965-0035-00		4F	960-7001-02
Sound	(256K)	965-0033-00		7F	960-5007-00
Robocop					
CPU	(256K)	965-0036-00	A3-4	B5	960-5007-00
CPU	(256K)	965-0037-00	A3-4	C5	960-5007-00
Voice 1	(512K)	965-0039-00		6F	960-7001-02
Voice 2	(512K)	965-0040-00		4F	960-7001-02
Sound	(256K)	965-0038-00		7F	960-5007-00
Phantom of the Opera					
CPU	(128K)	965-0026-00	A3-2	B5	960-5006-00
CPU	(256K)	965-0027-00	A3-2	C5	960-5007-00
Voice 1	(512K)	965-0029-00		6F	960-7001-02
Voice 2	(512K)	965-0030-00		4F	960-7001-02
Sound	(256K)	965-0028-00		7F	960-5007-00
Back to the Future					
CPU	(256K)	965-0041-00	A2-0	B5	960-5007-00
CPU	(256K)	965-0042-00	A2-0	C5	960-5007-00
Voice 1	(512K)	965-0044-00		6F	960-7001-02
Voice 2	(512K)	965-0045-00		4F	960-7001-02
Sound	(256K)	965-0043-00		7F	960-5007-00
The Simpsons					
CPU	(128K)	965-0051-00	A2-7	B5	960-5006-00
CPU	(256K)	965-0052-00	A2-7	C5	960-5007-00
Voice 1	(512K)	965-0054-00		6F	960-7001-02
Voice 2	(512K)	965-0055-00		4F	960-7001-02
Sound	(256K)	965-0053-00		7F	960-5007-00
Checkpoint					
CPU	(128K)	965-0056-00	A1-7	B5	960-5006-00
CPU	(256K)	965-0134-00	A1-7	C5	960-5007-00
Voice 1	(1M)	965-0057-00		F7	960-5009-00
Voice 2	(1M)	965-0058-00		F5	960-5009-00
Sound	(256K)	965-0059-00		F4	960-5007-00
Display	(512K)	965-0060-00	CP80	U8	960-7001-02
Teenage Mutant Ninja Turtles					
CPU	(128K)	965-0061-00	A1.04	B5	960-5006-00
CPU	(256K)	965-0062-00	A1.04	C5	960-5007-00
Voice 1	(1M)	965-0063-00		F5/6	960-5009-00
Voice 2	(1M)	965-0064-00		F4/5	960-5009-00
Sound	(256K)	965-0065-00		F7	960-5007-00
Display	(512K)	965-0066-00	A1.04	U8	960-7001-02
Batman					
CPU	(128K)	965-0067-00	A1.06	B5	960-5006-00
CPU	(256K)	965-0135-00	A1.06	C5	960-5007-00
Voice 1	(2M)	965-0068-00		U17	960-5010-00
Voice 2	(2M)	965-0069-00		U21	960-5010-00
Sound	(256K)	965-0070-00		U7	960-5007-00
Display	(1M)	965-0071-00	A1.06	U8	960-5009-00
Star Trek 25th Anniversary					
CPU	(512K)	965-0072-00	A2.01	C5	960-7001-02
Voice 1	(2M)	965-0073-00		U17	960-5010-00
Voice 2	(2M)	965-0074-00		U21	960-5010-00
Sound	(256K)	965-0075-00		U7	960-5007-00
Display	(1M)	965-0076-00	A1.09	U8	960-5009-00
Hook					
CPU	(512K)	965-0077-00	A4.08	C5	960-7001-02
Voice 1	(2M)	965-0078-00		U17	960-5010-00
Voice 2	(2M)	965-0079-00		U21	960-5010-00
Sound	(256K)	965-0080-00		U7	960-5007-00
Display	(1M)	965-0081-00	A4.01	U8	960-5009-00

EPROM	Chip Size	Program Part N ^o	USA Ver.	Bd. Loc.	Raw Part N ^o
Lethal Weapon 3					
CPU	(512K)	965-0082-00	A2.08	C5	960-7001-02
Voice 1	(2M)	965-0083-00		U17	960-5010-00
Voice 2	(2M)	965-0084-00		U21	960-5010-00
Sound	(256K)	965-0085-00		U7	960-5007-00
Display	(2M)	965-0086-00	A2.06	ROM 0	960-5010-00
Display	(2M)	965-0087-00	A2.06	ROM 1	960-5010-00
(Used on Display PCB 520-5055-00)					
Display	(4M)	965-0087-04	-OR- A2.06	ROM 0	960-5015-00
(Used on Display PCB 520-5055-01)					
Star Wars					
CPU	(512K)	965-0119-00	A1.03	C5	960-7001-02
Voice 0	(4M)	965-0132-00		U17	960-5015-00
Voice 1	(2M)	965-0133-00		U21	960-5010-00
Voice 2	(256K)	965-0131-00		U7	960-5007-00
Display	(2M)	965-0120-00	A1.04	ROM 0	960-5010-00
Display	(2M)	965-0121-00	A1.04	ROM 1	960-5010-00
(Used on Display PCB 520-5055-00)					
Display	(4M)	965-0122-00	-OR- A1.05	ROM 0	960-5015-00
(Used on Display PCB 520-5055-01)					
Rocky & Bullwinkle & Friends					
CPU	(512K)	965-0138-00	A1.30	C5	960-7001-02
Voice 0	(4M)	965-0139-00		U17	960-5015-00
Voice 1	(2M)	965-0140-00		U21	960-5010-00
Sound	(256K)	965-0141-00		U7	960-5007-00
Display	(4M)	965-0142-00	A1.30	ROM 0	960-5015-00
Jurassic Park					
CPU	(512K)	965-0143-00	A5.13	C5	960-7001-02
Voice 0	(4M)	965-0144-00		U17	960-5015-00
Voice 1	(2M)	965-0145-00		U21	960-5010-00
Sound	(256K)	965-0146-00		U7	960-5007-00
Display	(4M)	965-0147-00	A5.10	ROM 0	960-5015-00
Last Action Hero					
CPU	(512K)	965-0148-00	A1.12	C5	960-7001-02
Voice 0	(4M)	965-0149-00		U17	960-5015-00
Voice 1	(2M)	965-0150-00		U21	960-5010-00
Sound	(256K)	965-0151-00		U7	960-5007-00
Display	(4M)	965-0152-00	A1.06	ROM 0	960-5015-00
Tales from the Crypt					
CPU	(512K)	965-0157-00	A3.03	C5	960-7001-02
Voice 0	(4M)	965-0158-00		U17	960-5015-00
Voice 1	(2M)	965-0159-00		U21	960-5010-00
Sound	(256K)	965-0160-00		U7	960-5007-00
Display	(4M)	965-0161-00	A3.01	ROM 0	960-5015-00
The Who's Tommy					
CPU	(512K)	965-0162-00	A4.00	C5	960-7001-02
Voice 1	(4M)	965-0165-00		U17	960-5015-00
Voice 2	(4M)	965-0166-00		U21	960-5010-00
Voice 3	(4M)	965-0167-00		U36	960-5015-00
Voice 4	(4M)	965-0168-00		U37	960-5015-00
Sound	(512K)	965-0164-00		U7	960-7001-02
Display	(4M)	965-0163-00	A4.00	ROM 0	960-5015-00
WWF Royal Rumble					
CPU	(512K)	965-0169-00	A1.06	C5	960-7001-02
Voice 1	(4M)	965-0172-00		U17	960-5015-00
Voice 2	(4M)	965-0173-00		U21	960-5010-00
Voice 3	(4M)	965-0174-00		U36	960-5015-00
Sound	(512K)	965-0171-00		U7	960-7001-02
Display	(4M)	965-0170-00	A1.02	ROM 0	960-5015-00
Guns N' Roses					
CPU	(512K)	965-0175-00	A3.00	C5	960-7001-02
Voice 1	(4M)	965-0178-00		U17	960-5015-00
Voice 2	(4M)	965-0179-00		U21	960-5010-00
Voice 3	(4M)	965-0180-00		U36	960-5015-00
Voice 4	(4M)	965-0181-00		U37	960-5015-00
Sound	(512K)	965-0177-00		U7	960-7001-02
Display	(4M)	965-0176-00	A3.00	ROM 0	960-5015-00
Maverick *					
CPU	(512K)	965-0182-00	A4.04	C5	960-7001-02
Voice 1	(4M)	965-0186-00		U17	960-5015-00
Voice 2	(4M)	965-0187-00		U21	960-5010-00
Voice 3	(4M)	965-0187-01		U36	960-5015-00
Sound	(512K)	965-0185-00		U7	960-7001-02
Display*	(4M)	965-0183-00	A4.01	ROM 0	960-5015-00
Display*	(4M)	965-0184-00	A4.01	ROM 3	960-5015-00
Mary Shelley's Frankenstein *					
CPU	(512K)	965-0188-00	A1.03	C5	960-7001-02
Voice 1	(4M)	965-0192-00		U17	960-5015-00
Voice 2	(4M)	965-0193-00		U21	960-5010-00
Voice 3	(4M)	965-0194-00		U36	960-5015-00
Sound	(512K)	965-0191-00		U7	960-7001-02
Display*	(4M)	965-0189-00	A1.03	ROM 0	960-5015-00
Display*	(4M)	965-0190-00	A1.03	ROM 3	960-5015-00
Baywatch * (CPU Board 520-5003-04)					
CPU	(512K)	965-0195-00	A4.00	C5	960-7001-02
Voice 1	(4M)	965-0196-00		U17	960-5015-00
Voice 2	(4M)	965-0197-00		U21	960-5010-00
Sound	(512K)	965-0199-00		U7	960-7001-02
Display*	(4M)	965-0200-00	A4.00	ROM 0	960-5015-00
Display*	(4M)	965-0201-00	A4.00	ROM 3	

APPENDIX B

Semi-Conductors / Integrated Circuits (I.C.) / Relays Cross-Reference Table

Table No	Type	Source Number	STERN® PINBALL	N T E®	E C G®	Radio Shack®	R C A®
RECTIFICATION, BLOCKING, DAMPENING DIODES AND/OR LIGHT EMITTING DIODES (LEDs)							
1	Diode	1N4001	112-5001-00	NTE552	ECG552	- - - - -	SK9000
	Diode	1N4004	112-5003-00	NTE116	ECG116	276-1103	SK3312
	Diode	1N5401	112-0056-00	NTE5801	ECG5801	276-1143	SK9004
	Diode	1N5404	112-5004-00	NTE5804	ECG5804	276-1144	SK9007
	Diode	T6A10L	112-5006-01	NTE5812	ECG5812	- - - - -	- - - - -
	Diode	FR302	112-5009-00	NTE588	ECG588	- - - - -	SK5014
	Diode, Signal	1N914	112-5014-00	- - - - -	- - - - -	- - - - -	- - - - -
LED	MT5000UR or TLRH180P (T1-3/4 GaAlAs)	165-5052-00 <i>(old SPI Part No: 165-5100-00)</i>	- - - - -	- - - - -	276-066B	- - - - -	
ZENER DIODES							
2	Diode	1N4742A 12v	112-0061-00	NTE142A	ECG142A	276-563	SK12V
	Diode	1N4760B 68v	112-0062-00B	NTE5092A	ECG5092A	- - - - -	SK68V
	Diode	1N4764A 100v	112-0049-00A	NTE5096A	ECG5096A	- - - - -	SK100V
	Diode	1N5228 3.9v	112-0053-00	NTE5007A	ECG5007A	- - - - -	SK3A9
	Diode	1N5234B 6.2v	112-0047-00B	NTE5013A	ECG5013A	276-561	SK6A2
	Diode	1N5379 110v	112-0072-00	NTE5157	ECG5157	- - - - -	SK110X
	Diode	1N6267A 6.8v	112-5011-00	NTE4902	ECG4902	- - - - -	- - - - -
	Diode	1N4752A 33v	112-5010-00A	NTE147A	ECG147A	- - - - -	SK33V
Diode	1N4736 6.8v 1w	112-5007-00	NTE5071A	ECG5071A	- - - - -	- - - - -	
TRANSISTORS - TYPE FET, NPN, PNP AND/OR SCR							
3	FET Trans.	STP20N10L	110-0106-00	NTE2987	ECG2987	- - - - -	- - - - -
	FET Trans.	STP19N06L	110-0088-00	NTE2985	ECG2985	- - - - -	- - - - -
	FET Trans.	VN02N	110-0089-00	- - - - -	- - - - -	- - - - -	- - - - -
	NPN Trans.	2N4401	110-0073-00	NTE85	ECG85	276-2009	SK3124A
	NPN Trans.	2N6427	110-0070-00	NTE48	ECG48	- - - - -	SK4906
	NPN Trans.	MJE340	110-0071-00	NTE157	ECG157	- - - - -	SK3747
	NPN Trans.	MPSA42	110-0082-00	NTE287	ECG287	- - - - -	SK3232
	NPN Trans.	2N3904	110-0069-00	NTE123AP	ECG123AP	276-2009	- - - - -
	NPN Trans.	TIP122	110-0067-00	NTE261	ECG261	276-2068	SK3896
	NPN Trans.	MJE15030	110-0101-00	NTE375	ECG375	- - - - -	SK9118
	PNP Trans.	2N5401	110-0078-00	NTE288	ECG288	- - - - -	SK3434
	PNP Trans.	MJE15031	110-0103-00	NTE292	ECG292	- - - - -	SK3441
	PNP Trans.	MJE350	110-0072-00	NTE374	ECG374	- - - - -	SK9042
	PNP Trans.	MPSA92	110-0100-00	NTE288	ECG278	- - - - -	SK3434
	PNP Trans.	TIP42	110-0068-00	NTE332	ECG332	- - - - -	SK9236
	PNP Trans.	TIP32C	110-0081-00	NTE292	ECG292	- - - - -	SK3441
	PNP Trans.	TIP36C	110-0077-00	NTE393	ECG393	- - - - -	SK3961
	SCR Trans.	2N5060	110-0074-00	NTE5400	ECG5400	276-1067	SK3950
SCR Trans.	SCR2800B	110-0083-00	NTE5461-8	ECG5461-8	- - - - -	- - - - -	
BRIDGE RECTIFIERS (BR)				Comments:			
4	BR (Present)	DB3501 or CM3501	112-5000-00	For White Star I/O Bds., BR = 35 Amp @ 100v P.I.V.			
RELAYS				Comments:			
5	Relay	FRL-264 D024/02CK	190-5002-00	For PPB, Power Supply, & White Star I/O Boards, Relay = 24v DC 10 Amp DPDT			
	Relay	FRL-264 D006/04CV	190-5001-00	For CPU Boards, Relay = 6v DC 5 Amp 4 Pole DT			





APPENDIX C

Production Start Date, Manual Part No., ROM Size & Positions and Jumper W6 Installed Note‡ (White Star Board System & S.A.M. System Only*)



Game Name White Star Bd. System™	Production Start Date and Manual Part Nr.	CPU/Sound Board Sound U7 512K CPU/Sound Board Game U210 1MB CPU/Sound Board Voice ROMS:				Jumper Installed (‡ see Note)	
		U17	U21	U36	U37		
* Note: For complete Appendix Information for Games <i>Laser War</i> through <i>Batman Forever</i> , see any Service Game Manual between <i>Apollo 13</i> through <i>Ripley's Believe It or Not!</i> or on-line at our website www.sternpinball.com/parts.htm ; also available on CD-R, 970-2003-00 (<i>The Simpsons™ Pinball Party</i> , <i>T3®</i> and <i>The Lord of the Rings™</i>).							
29	Apollo 13 (A13)	NOV 95 780-5044-00	4MB	4MB	4MB	Not Used	n / a
30	Golden Eye	FEB 96 780-5042-00	4MB	4MB	Not Used	Not Used	n / a
31	Twister	APR 96 780-5041-00	4MB	4MB	Not Used	Not Used	n / a
32	ID4: Independence Day	JUL 96 780-5045-00	4MB	4MB	Not Used	Not Used	n / a
33	Space Jam	OCT 96 780-5043-00	4MB	4MB	4MB	Not Used	n / a
34	The Star Wars Trilogy - Sp. Ed.	FEB 97 780-5056-00	4MB	4MB	Not Used	Not Used	n / a
35	The Lost World: Jurassic Park	JUN 97 780-5053-00	4MB	4MB	Not Used	Not Used	n / a
36	The X-Files	AUG 97 780-5046-00	4MB	4MB	Not Used	Not Used	n / a
37	Starship Troopers	NOV 97 780-5059-00	4MB	4MB	4MB	Not Used	n / a
38	Viper Night Drivin'	FEB 98 780-5035-00	4MB	4MB	4MB	4MB	n / a
39	Lost In Space	JUN 98 780-5060-00	4MB	4MB	4MB	4MB	n / a
40	Godzilla	SEP 98 780-5040-00	4MB	4MB	4MB	4MB	n / a
41	South Park	JAN 99 780-5071-00	8MB	8MB	8MB	8MB	W6
42a	Harley-Davidson®	AUG 99 780-5067-01	8MB	8MB	8MB	8MB	W6
42b	Harley-Davidson® 2nd Ed.	SEP 02 780-5067-10	8MB	8MB	8MB	8MB	W6
42c	Harley-Davidson® 3rd Ed.	OCT 04 780-5087-00	8MB	8MB	8MB	8MB	W6
43a	Striker Xtreme	MAR 00 780-5068-01	8MB	8MB	8MB	8MB	W6
43b	NFL	OCT 00 780-5073-00	8MB	8MB	8MB	8MB	W6
44	Sharkey's Shootout	JUL/OCT 00 780-5072-01	8MB	8MB	8MB	Not Used	W6
45	High Roller Casino	JAN 01 780-5065-00	8MB	8MB	8MB	8MB	W6
46	Austin Powers™	MAY 01 780-5074-00	8MB	8MB	8MB	8MB	W6
47	MONOPOLY®	SEP 01 780-5075-00	8MB	8MB	8MB	Not Used	W6
48	Playboy	FEB 02 780-5076-00	8MB	8MB	8MB	8MB	W6
49	RollerCoaster Tycoon™	AUG 02 780-5078-00	8MB	8MB	8MB	Not Used	W6
50	The Simpsons™ Pinball Party	JAN 03 780-5077-00	8MB	8MB	8MB	8MB	W6
51	T3®: Rise of the Machines™	MAY 03 780-5079-00	8MB	8MB	8MB	8MB	W6
52	The Lord of the Rings™	NOV 03 780-5080-00	8MB	8MB	8MB	8MB	
53	Ripley's Believe It or Not!®	APR 04 780-5081-00	8MB	8MB	8MB	8MB	

‡ Additional Information for **Installed Jumper** (above games 41-51):

• Installed **W6** so 8MB ROMS can be utilized. See the **CPU/Sound Board Schematic** (Sheet 2 of 3, Address Location 3E) in the games' Service Game Manual. Games 52 - 57 CPU/Sound Board differ than <51 (See Appendix D).

See **Apdx. A** for more detailed information on **Pinball Game Firmware** (ROM Name, Size, Part Numbers, USA Version & Checksum and Board Locations).

Game Name White Star Board System™	Production Start Date and Manual Part Nr.	CPU/Sound Board Sound U7 512K CPU/Sound Board Game U210 1MB CPU/Sound Board Voice ROMS:				
		U17	U21	U36	U37	
54	Elvis®	AUG 04 780-5084-00	8MB	8MB	8MB	8MB
55	The Sopranos™	FEB 05 780-5085-00	8MB	8MB	8MB	8MB
56	NASCAR®	JUL 05 780-5086-00	8MB	8MB	8MB	8MB
57	Grand Prix	SEP 05 780-5091-00	8MB	8MB	8MB	8MB

See **Apdx. A** for more detailed information on **Pinball Game Firmware** (ROM Name, Size, Part Numbers, USA Version & Checksum and Board Locations).

Game Name S.A.M. System	Production Start Date and Manual Part Nr.	S.A.M. System CPU/Sound Board Boot EPROM U9			
		965-BOOT-SAM (Programmed)			
58	World Poker Tour™ (WPT)	JUN 06 780-5088-00	8MB	B-02 V2.1+ chksum \$F625	LOC: U9
59	The Simpsons™ Kooky Carnival	APR 06 780-5090-00	8MB	B-02 V2.1+ chksum \$F625	LOC: U9
60	©Disney's Pirates of the Caribbean	AUG 06 780-5092-00	8MB	B-02 V2.1+ chksum \$F625	LOC: U9
61	Famil Guy™	DEC 06 780-5093-00	8MB	B-02 V2.1+ chksum \$F625	LOC: U9
62	Spider-Man™	MAY 07 780-5094-00	8MB	B-02 V2.1+ chksum \$F625	LOC: U9

Games 58 – current, S.A.M. System : CPU/Sound & I/O Power Driver PCBs differ than White Star (previous Games 29 – 57); Disp. Controller Not Required.





APPENDIX D

Board Type (White Star Board System* Only) Table



Game Name	Flipper	I/O Power Driver	CPU/Sound Stereo	Disp. Power Supply	Dot Matrix Display	Display Controller	OPTO Transmitter	OPTO Receiver	OPTO Application
Apollo 13	520-5080-00 2-Flipper	520-5137-00	520-5136-00	520-5138-00	520-5052-00 128 X 32 Dots	520-5055-01	520-5124-00 Single OPTO	520-5125-00 Single OPTO	5-Ball Trough over Up-Kicker
	Miscellaneous PC Boards:	Light Boards 520-5130-01, -04 & -05 Magnet Interface, 7-Segment Display & Light Bd. 520-5130-06 Magnet Driver Board 520-5130-02 Switch Membrane Board 520-5130-03				Relay Board 520-5010-00			
Golden Eye	520-5080-00 2-Flipper	520-5137-00	520-5136-00	520-5138-00	520-5052-00 128 X 32 Dots	520-5055-01	520-5124-00 Single OPTO	520-5125-00 Single OPTO	5-Ball Trough over Up-Kicker
	Miscellaneous PC Boards:	Light Boards 520-5128-05 through -08		Mag. Processor X2 Driver Bd. 520-5143-00	Relay Board 520-5010-00				

GAMES HEREON NO LONGER REQUIRE THE FLIPPER BOARD WITH THE WHITE STAR BOARD SYSTEM™

Game Name	I/O Power Driver	CPU/Sound Mono	Disp. Power Supply	Dot Matrix Display	Display Controller	OPTO Transmitter	OPTO Receiver	OPTO Application	Misc OPTO & App.
Twister	520-5137-01	520-5136-10	520-5138-00	520-5052-00 128 X 32 Dots	520-5055-01	520-5124-00 Single OPTO	520-5125-00 Single OPTO	5-Ball Trough over Up-Kicker	
	Miscellaneous PC Boards:	Light Boards 520-5145-01 through -07		Mag. Drv. Bd. 520-5143-00	Relay Board 520-5010-00				
Independence Day (ID4)	520-5137-01	520-5136-10	520-5138-00	520-5052-00 128 X 32 Dots	520-5055-01	520-5124-00 Single OPTO	520-5125-00 Single OPTO	4-Ball Trough over Up-Kicker	
	Miscellaneous PC Boards:	Light Boards 520-5149-01 through -10		Servo Mtr. Bd. 520-5152-00		520-5082-00 Long Hop OPTO	520-5083-00 Long Hop OPTO	Alien Head Enter	
Space Jam	520-5137-01	520-5136-10	520-5138-00	520-5052-00 128 X 32 Dots	520-5055-01	520-5124-00 Single OPTO	520-5125-00 Single OPTO	5-Ball Trough over Up-Kicker	
	Miscellaneous PC Boards:	2X 7-Segment Display Board 520-5153-00							
The Star Wars Trilogy - Special Ed.	520-5137-01	520-5136-10	520-5138-00	520-5052-00 128 X 32 Dots	520-5055-01	520-5124-00 Single OPTO	520-5125-00 Single OPTO	4-Ball Trough over Up-Kicker	
	Miscellaneous PC Boards:	Relay Board 520-5010-00							
The Lost World: J.P.	520-5137-01	520-5136-10	520-5138-00	520-5052-00 128 X 32 Dots	520-5055-01	520-5124-00 Single OPTO	520-5125-00 Single OPTO	4-Ball Trough over Up-Kicker	520-5162-00 2-Pos. Motor Sensor on Snagger Motor
	Miscellaneous PC Boards:	DC Relay Bd. 520-5066-00	Shaker Mtr. Bd. 520-5065-00						
The X-Files	520-5137-01	520-5136-10	520-5138-00	520-5052-00 128 X 32 Dots	520-5055-01	520-5124-00 Single OPTO	520-5125-00 Single OPTO	4-Ball Trough over Up-Kicker	520-5155-00 3-Pos. Motor Sensor on File Cab. Motor
	Miscellaneous PC Boards:					520-5082-00 Long Hop OPTO	520-5083-00 Long Hop OPTO	File Cabinet Enter	
Starship Troopers	520-5137-01	520-5136-15	520-5138-00	520-5052-00 128 X 32 Dots	520-5055-02	520-5124-00 Single OPTO	520-5125-00 Single OPTO	4-Ball Trough over Up-Kicker	
	Miscellaneous PC Boards:	4X 7-Segment Display Board 520-5166-00				520-5082-00 Long Hop OPTO	520-5083-01 Long Hop OPTO	L/R Orbit Lane Enter	
Viper Night Drivin'	520-5137-01	520-5136-16	520-5138-00	520-5052-00 128 X 32 Dots	520-5055-03	520-5124-00 Single OPTO	520-5125-00 Single OPTO	4-Ball Trough over Up-Kicker	
	Miscellaneous PC Boards:	Relay Board 520-5010-00				520-5082-00 Long Hop OPTO	520-5083-01 Long Hop OPTO	Jump Ramp	
Lost In Space	520-5137-01	520-5136-16	520-5138-00	520-5052-00 128 X 32 Dots	520-5055-03	515-0173-00 Dual OPTO	515-0174-00 Dual OPTO	4-Ball Trough over Up-Kicker	
	Miscellaneous PC Boards:	Relay Board 520-5010-00							
Godzilla	520-5137-01	520-5136-16	520-5138-00	520-5052-00 128 X 32 Dots	520-5055-03	515-0173-00 Dual OPTO	515-0174-00 Dual OPTO	4-Ball Trough over Up-Kicker	
	Miscellaneous PC Boards:	Shaker Mtr. Bd. 520-5065-00							
South Park	520-5137-01	520-5136-16	520-5138-00	520-5052-00 128 X 32 Dots	520-5055-03	515-0173-00 Dual OPTO	515-0174-00 Dual OPTO	5-Ball Trough over Up-Kicker	
	Miscellaneous PC Boards:					520-5082-00 Long Hop OPTO	520-5083-01 Long Hop OPTO	Kenny Under Trough Enter	
Harley-Davidson® 1st-3rd* Editions	520-5137-01	520-5136-16 *520-5300-00*	520-5138-00	520-5052-00 128 X 32 Dots	520-5055-03	515-0173-00 Dual OPTO	515-0174-00 Dual OPTO	4-Ball Trough over Up-Kicker	
	Miscellaneous PC Boards:	Relay Board 520-5010-00		Shaker Mtr. Bd. 520-5065-00	Diode Board 520-5146-00	520-5082-00 Long Hop OPTO	520-5083-01 Long Hop OPTO	Motorcycle Enter	
Striker Xtreme (NFL)	520-5137-01	520-5136-16	520-5138-00	520-5052-00 128 X 32 Dots	520-5055-03	515-0173-00 Dual OPTO	515-0174-00 Dual OPTO	4-Ball Trough over Up-Kicker	520-5155-00 3-Pos. Motor Sensor on Goalie Motor
	Miscellaneous PC Boards:	DC Relay Bd. 520-5066-00	Relay Board 520-5010-00	Diode Board 520-5146-00	for UK ONLY- Solenoid Expander Bd. 520-5192-00	520-5082-00 Long Hop OPTO	520-5083-01 Long Hop OPTO	Goalie Under- Trough Enter	
Sharkey's Shootout	520-5137-64	520-5136-64	520-5138-00	520-5052-00 128 X 32 Dots	520-5055-03	515-0173-00 Dual OPTO	515-0174-00 Dual OPTO	4-Ball Trough over Up-Kicker	520-5194-00 4-Pos. Motor Sensor on ? -Ball Motor
	Miscellaneous PC Boards:	Relay Board 520-5010-00		Sol. Exp. Bd. 520-5192-00					
High Roller Casino	520-5137-01	520-5136-16	520-5138-00	520-5052-00 128 X 32 Dots	520-5055-03	515-0173-00 Dual OPTO	515-0174-00 Dual OPTO	4-Ball Trough over Up-Kicker	520-5194-00 4-Pos. Motor Sensor on Roulette Wheel Motor
	Miscellaneous PC Boards:	Dot Display (5X7) in Slot Mach. 520-5197-00			for UK ONLY- Solenoid Expander Bd. 520-5192-00	520-5196-00 3-Pos. OPTO	520-5195-00 3-Pos. OPTO	Ball Lock under Roulette	Up/Dn Ramp in Slot Mach.
Austin Powers™	520-5137-01	520-5136-16	520-5138-00	520-5052-00 128 X 32 Dots	520-5055-03	515-0173-00 Dual OPTO	515-0174-00 Dual OPTO	4-Ball Trough over Up-Kicker	520-5212-00 Pulse-Stretcher OPTO on Spini-Me
	Miscellaneous PC Boards:	Relay Bd. (X3) 520-5010-00			for UK ONLY- Solenoid Expander Bd. 520-5192-00	520-5082-00 Long Hop OPTO	520-5083-01 Long Hop OPTO	Time Machine Ramp	
MONOPOLY®	520-5137-01	520-5136-16	520-5138-00	520-5052-00 128 X 32 Dots	520-5055-03	515-0173-00 Dual OPTO	515-0174-00 Dual OPTO	4-Ball Trough over Up-Kicker	
	Miscellaneous PC Boards:	DC Relay Bd. 520-5066-00	Mini-Dot Display (3 by 5X7) 520-5197-00 (Electric C Sign)		for UK ONLY- Solenoid Expander Bd. 520-5192-00	520-5218-00 4-Pos. OPTO	520-5210-00 4-Pos. OPTO	Bank Door	

Table continued on the next page.





APPENDIX D

Board Type (White Star Board System* & S.A.M. System** Only) Table



Game Name	I/O Power Driver	CPU/Sound (old & new)	Disp. Power Supply	Dot Matrix Display	Display Controller	OPTO Transmitter	OPTO Receiver	OPTO Application	Misc OPTO & App.
Playboy	520-5137-01	520-5136-16	520-5138-00	520-5052-00 128 X 32 Dots	520-5055-03	515-0173-00 Dual OPTO	515-0174-00 Dual OPTO	4-Ball Trough over Up-Kicker	
	Miscellaneous PC Boards:	DC Relay Bd. 520-5066-00	Relay Bd. 520-5010-00		for UK ONLY- Solenoid Expander Bd. 520-5192-00				
RollerCoaster Tycoon™	520-5137-01	520-5136-16	520-5138-00	520-5052-00 128 X 32 Dots	520-5055-03	515-0173-00 Dual OPTO	515-0174-00 Dual OPTO	4-Ball Trough over Up-Kicker	520-5222-00 1-Position Switch Detect on Wheel Spin
	Miscellaneous PC Boards:	DC Relay Bd. 520-5066-00	Mini-Dot Display (3 by 5X7) 520-5221-00 (Ramp Enter Sign)		for UK ONLY- Solenoid Expander Bd. 520-5192-00	520-5082-00 Long Hop opto	520-5083-01 Long Hop opto	Behind 1-Bank Drop Target	
The Simpsons™ Pinball Party	520-5137-01	520-5136-16	520-5138-00	520-5052-00 128 X 32 Dots	520-5055-03	515-0173-00 Dual OPTO	515-0174-00 Dual OPTO	4-Ball Trough over Up-Kicker	
	Miscellaneous PC Boards:	LED Bd. 520-5219-00	Color Dot Display (4 by 5X7) 520-5225-00 (TV Set)		for UK ONLY ◀◀◀ Aux. Driver Bd. 520-5068-01				
Terminator® 3: Rise of the Machines™	520-5137-01	520-5136-16	520-5138-00	520-5052-00 128 X 32 Dots	520-5055-03	515-0173-00 Dual OPTO	515-0174-00 Dual OPTO	4-Ball Trough over Up-Kicker	
	Miscellaneous PC Boards:				for UK ONLY ◀◀◀ Aux. Driver Bd. 520-5068-01	515-7307-00 Single OPTO	515-7308-00 Single OPTO	TXCannon Trough	
The Lord of the Rings™	520-5137-01	New 520-5300-00	520-5138-00	520-5052-00 128 X 32 Dots	520-5055-03	515-0173-00 Dual OPTO	515-0174-00 Dual OPTO	4-Ball Trough over Up-Kicker	500-6746-00 (White Trans.) 500-6747-00 (Black Rec.)
	Miscellaneous PC Boards:	19-LED PCB 520-5242-00	OPTO Transmitter / Receiver Amplifier PCB 520-5239-00		for UK ONLY ◀◀◀ Aux. Driver Bd. 520-5068-01	515-7307-00 Single OPTO	515-7308-00 Single OPTO	Orthanc Tower Trough	
Ripley's Believe It or Not!®	520-5137-01	520-5300-00	520-5138-00	520-5052-00 128 X 32 Dots	520-5055-03	515-0173-00 Dual OPTO	515-0174-00 Dual OPTO	4-Ball Trough over Up-Kicker	500-6775-00 OPTO Trnscvr
	Miscellaneous PC Boards:	520-5236-00 X3 Dot Display	OPTO Transmitter / Receiver Amplifier PCB 520-5239-01		for UK ONLY ◀◀◀ Aux. Driver Bd. 520-5068-01	520-5234-00 3-Pos. OPTO	520-5234-00 3-Pos. OPTO	Vari-Target	520-5235-03 X3 Aux. Drvr
Elvis®	520-5137-01	520-5300-00	520-5138-00	520-5052-00 128 X 32 Dots	520-5055-03	515-0173-00 Dual OPTO	515-0174-00 Dual OPTO	4-Ball Trough over Up-Kicker	
	Miscellaneous PC Boards:				for UK ONLY ◀◀◀ Aux. Driver Bd. 520-5068-01				
The Sopranos™	520-5137-01	520-5300-00	520-5138-00	520-5052-00 128 X 32 Dots	520-5055-03	515-0173-00 Dual OPTO	515-0174-00 Dual OPTO	4-Ball Trough over Up-Kicker	
	Miscellaneous PC Boards:				for UK ONLY ◀◀◀ Aux. Driver Bd. 520-5068-01				
NASCAR® and [NDSE]	520-5137-01	520-5300-00	520-5138-00	520-5052-00 128 X 32 Dots	520-5055-03	515-0173-00 Dual OPTO	515-0174-00 Dual OPTO	4-Ball Trough over Up-Kicker	500-6775-00 OPTO Trans. (Qty. 16) Switch Detect.
	Miscellaneous PC Boards:	520-5235-03 X3 Aux. Drvr	OPTO Transmitter / Receiver Amplifier PCB 520-5239-01		for UK ONLY ◀◀◀ Aux. Driver Bd. 520-5068-01				
Grand Prix	520-5137-01	520-5300-00	520-5138-00	520-5052-00 128 X 32 Dots	520-5055-03	515-0173-00 Dual OPTO	515-0174-00 Dual OPTO	4-Ball Trough over Up-Kicker	500-6775-00 OPTO Trans. (Qty. 16) Switch Detect.
	Miscellaneous PC Boards:	520-5235-03 X3 Aux. Drvr	OPTO Transmitter / Receiver Amplifier PCB 520-5239-01		for UK ONLY ◀◀◀ Aux. Driver Bd. 520-5068-01				

Game Name	I/O Power Driver**	CPU / Sound**	Disp. Power Supply	Dot Matrix Display	Dual OPTO Transmitter	Dual OPTO Receiver	Dual OPTO Transceiver	OPTO Transceiver Miscellaneous
World Poker Tour™ (WPT)	520-5249-00 Backbox	520-5246-00 Backbox	520-5138-00 Backbox	520-5052-00 128 X 32 Dots	515-0173-00 4-Ball Trough	515-0174-00 4-Ball Trough	500-6775-00 4 Switch Pairs (Qty. 8)	520-5251-00 'U' 1/per PCB Jail Bars Up Ace/Hole Mech 520-5252-04 'U' 4/per PCB Drop Targets 4- & 8- Banks
	Miscellaneous PCBs:	520-5254-00 50V Step-Up Drv	520-5250-14 14LED 5X7 Disp.	520-5239-01 OPTO Amplifier	520-5247-00 Ace/Hole Mech	520-5248-00 Ace/Hole Mech		
The Simpsons™ Kooky Carnival	520-5249-00 Back Door	520-5246-00 Back Door	520-5138-00 Cabinet Rear	520-5052-00 128 X 32 Dots			520-5253-00-ASY Coin Drop (Qty. 11)	
	Miscellaneous PCBs:	515-5742-00 Shaker PCB	500-6700-00 Relay (incl. Wiring + Conn.)					
©Disney's Pirates of the Caribbean	520-5249-00 Backbox	520-5246-00 Backbox	520-5138-00 Backbox	520-5052-00 128 X 32 Dots	515-0173-00 4-Ball Trough	515-0174-00 4-Ball Trough	500-6775-00 5 Switch Pairs (Qty. 10)	
	Miscellaneous PCBs:	520-5239-01 OPTO Amp. (X3)	511-5024-03 Relay (incl. Wiring + Conn.)					
Family Guy™	520-5249-00 Backbox	520-5246-00 Backbox	520-5138-00 Backbox	520-5052-00 128 X 32 Dots	515-0173-00 4-Ball Trough	515-0174-00 4-Ball Trough	500-6775-00 3 Switch Pairs (Qty. 6)	520-5252-01 'U' 1/per PCB Drop Target 1-Bank
	Miscellaneous PCBs:	520-5239-01 OPTO Amp. (X2)	520-5261-00 Stepper Motor	511-5042-01 Trgt. Sensor (X2)			500-6775-01 1 Switch Pair (Qty. 2)	520-5252-04 'U' 4/per PCB Drop Target 4-Bank
			511-5046-00 : Mini Playfield Lamp PCB					
Spider-Man™	520-5249-00 Backbox	520-5246-00 Backbox	520-5138-00 Backbox	520-5052-00 128 X 32 Dots	515-0173-00 4-Ball Trough	515-0174-00 4-Ball Trough	500-6775-00 3 Switch Pairs (Qty. 6)	
	Miscellaneous PCBs:	520-5239-01 OPTO Amp. (X2)						



APPENDIX D

Board Type Table

Game Name	Flipper	Sound	Power Supply	Display X-Digit
<ul style="list-style-type: none"> • Laser War 	2-Flipper Board Not Required	<i>initial:</i> 520-5002-00 <i>replaced with:</i> 520-5002-02 <i>520-5002-01 was not used.</i>	520-5000-00	Master: 520-5004-00 plus: 520-5005-00 (Qty. 2): 7 Digit Alpha/Numeric 520-5006-00 (Qty. 2): 7 Digit Numeric 520-5007-00 (Qty. 1): 4 Digit Numeric
<ul style="list-style-type: none"> • Secret Service • Torpedo Alley 	3-Flipper Board Not Required	520-5002-02		520-5014-01 7 Digit Alpha/Numeric Combined
<ul style="list-style-type: none"> • Time Machine 	2-Flipper Board Not Required			520-5030-00 16 Digit Alpha/Numeric Combined
<ul style="list-style-type: none"> • Playboy 35th Anniversary * • ABC Monday Night Football * • Robocop • Phantom of the Opera • Back to the Future • The Simpsons 	520-5033-00 2-Flipper <i>(*only for 100 games of Playboy 35th Anniv. & ABC Mon. Night Football)</i>			
		520-5002-03		

Game Name	Flipper	Sound	Power Supply	Dot Matrix Display	Display Controller	OPTO Transmitter	OPTO Receiver	OPTO Application		
<ul style="list-style-type: none"> • Checkpoint • Teenage Mutant Ninja Turtles 	520-5033-00 2-Flipper	520-5002-03	520-5047-00	520-5042-00 128 X 16	520-5055-00					
<ul style="list-style-type: none"> • Batman • Star Trek 25th Anniv. • Hook 		520-5050-01								
<ul style="list-style-type: none"> • Lethal Weapon 3 		520-5050-02	520-5047-01							
<ul style="list-style-type: none"> • Star Wars • Rocky & Bullwinkle & Friends 		520-5050-03	520-5047-02	520-5052-00 128 X 32						
<ul style="list-style-type: none"> • Jurassic Park 		520-5076-00 3-Flipper								
<ul style="list-style-type: none"> • Last Action Hero 		520-5076-00 2-Flipper	520-5077-00							
<ul style="list-style-type: none"> • Tales from the Crypt • The Who's Tommy 		520-5076-00 3-Flipper	520-5047-03	520-5075-00 192 X 64					520-5092-01	
<ul style="list-style-type: none"> • WWF Royal Rumble 		520-5070 / 5080 -00 4-Flipper (2X2)								
<ul style="list-style-type: none"> • Guns N' Roses 		520-5076-00 3-Flipper	520-5050-03	520-5102-00 Single OPTO					520-5103-00 Single OPTO	Paddle Boat Wheel Enter
<ul style="list-style-type: none"> • Mary Shelley's Frankenstein 		520-5076-00 3-Flipper	520-5077-00	520-5124-00 Single OPTO					520-5125-00 Single OPTO	5-Ball Trough over Up-Kicker
<ul style="list-style-type: none"> • Baywatch 	520-5070 / 5080 -00 4-Flipper (2X2)	520-5126-02	520-5124-00 Single OPTO	520-5125-00 Single OPTO	4-Ball Trough over Up-Kicker					
<ul style="list-style-type: none"> • Batman Forever 	520-5076-00 3-Flipper									

Miscellaneous Boards (Lamp Boards & Relay Boards) not listed above can be found in each individual game manual.





APPENDIX E

Flipper Coil (White Star Board System* & S.A.M. System** Only) Table



Typical Coil Diode 1N4004 unless noted otherwise (Diode Top = above lugs next to windings; Diode Below (Bottom) = under lugs opposite of windings).

STANDARD COILS (TYPICAL APPLICATIONS)			LARGE COILS (FLIPPERS & SPECIAL APPLICATIONS)		
Ga.-Turn	Res (Ω)	SPI Part Number and Comments	Ga.-Turn	Res (Ω)	SPI Part Number and Comments
20-400	1.0 Ω	090-5021-use : -00 Diode Top	21-900	call Ω	090-5020-use : -01 3-Lugs + 1N4004 & 1N5404 Diodes -10 Diode Top <BROWN><RED>
22-500	1.7 Ω	090-5017-use : -00 Diode Top	22-750 / 30-2600	2.6 Ω 92.0 Ω	090-5011-use : -00 DUAL WND COIL // 3-Lugs Diode x2
22-600	2.2 Ω	090-5017-use : -0B Diode Below // -0T Diode Top			
23-700	3.1 Ω	090-5022-use : -0B Diode Below // -0T Diode Top	22-900	3.45 Ω	090-5020-use : -20T Diode Top <YELLOW> // -20-ND No Diode
23-750	3.4 Ω	090-5019-use : -00 Diode Top			
23-800	3.6 Ω	090-5001-use : -0B Diode Below // -0T Diode Top // -NL No Lugs 11" Leads // -ND No Diode	22-1080	4.2 Ω	090-5032-use : -0B D. Below // -0T D. Top <YEL-GRN> -NL No Diode
23-840	4.0 Ω	090-5005-use : -00 Diode Top			
23.5-765	3.6 Ω	090-5037-use : -03 Diode Top	23-620 / 30-2600	2.4 Ω 75.0 Ω	090-5006-use : -00 DUAL WND COIL // 3-Lugs Diode x2
24-900	5.0 Ω	090-5002-use : -02 Diode Top // -10 No Lugs 14" Leads			
24-940	5.5 Ω	090-5036-use : -0B Diode Below // -0T Diode Top use 090-5051-01 No Lugs 11" Leads	23-700 / 30-2600	3.0 Ω 83.5 Ω	090-5013-use : -00 DUAL WOUND COIL // Diode Top
25-1240	9.3 Ω	090-5034-use : -00 Diode Below			
26-1200	10.3 Ω	090-5044-use : -0B Diode Below // -0T Diode Top // -NL No Lugs 11" Leads // -ND No Diode	23-800 / 30-2600	2.4 Ω 90.5 Ω	090-5012-use : -00 DUAL WOUND COIL // Diode Top
27-1300	14.2 Ω	090-5003-use : -0T Diode Top			
27-1400	14.7 Ω	090-5015-use : -00 Diode Below	23-1100	5.1 Ω	090-5030-use : -0T Diode Top <ORANGE> -ND No Diode
27-1400		511-5031-00 Special App.: No Diode / Lugs + Conn.			
27-1500	16.3 Ω	090-5004-use : -0B Diode Below // -0T Diode Top	23-1200	7.1 Ω	090-5008-use : -00 Diode Top <BLACK>
29-2000	33.6 Ω	090-5016-use : -00 Diode Top	23-1500	4.4 Ω	090-5062-use : -00 Diode Top <BLUE>
LARGE, MEDIUM & MINI COILS (MAGNET APPLICATIONS)			24-1570	9.5 Ω	090-5025-use : -00 Diode Top <BLUE>
20.5-480	2.9 Ω	090-5064-use : -02 No Lugs or Core; 14" Leads // Large	25-1400	call Ω	090-5067-use : -0T Diode Top <RED>
22-650	4.3 Ω	090-5042-use : -00 No Lugs or Core; 6" Leads // Large	25-1600	call Ω	090-5068-use : -0T Diode Top <WHITE>
		090-5042-use : -01 No Lugs or Core; 12" Leads // Large	25-1800	13.8 Ω	090-5041-use : -0T Diode Top <BLUE-GREEN>
24-780	8.0 Ω	090-5061-use : -00 No Lugs or Core; 6" Lds. // Medium	MINI COILS (RESET / TRIP APPLICATIONS)		
29-1000	15.2 Ω	090-5059-use : -00 Lugs + Diode + Magnet Core // Mini	27-950	call Ω	090-5046-use : -01 Diode Top
31-1500	52.0 Ω	090-5054-00 : Straight Lugs + Diode + Mag Core // Mini	28-1050	11.5 Ω	090-5046-use : -00 Diode Top
		090-5055-00 : 90° Lugs + Diode + Magnet Core // Mini	27-880	call Ω	500-6976-01 No Lugs or Diode + 6" Leads & Conn.
Please Note: Ohm values may vary +/- .03 depending on meter calibration.			31-590	call Ω	090-5010-use : -00 Diode Top
Ordering Note: Coils typically should not come with Coil Sleeves. IF A SLEEVE EXISTS, ensure it is the correct sleeve for the application usage. For the correct Coil Sleeve, refer to the Game Assembly Drawing the coil exists on and order separately.			32-1250	35.0 Ω	515-6916-01 : includes Flap & Screw <YELLOW>
			32-1800	50.2 Ω	090-5031-use : -0B Diode Below // -0T Diode Top (515-6110-00) use 515-# to include mounting & armature brackets
			33-1590	59.0 Ω	515-6916-00 : includes brackets <WHITE>

Flipper Coil (White Star Board System* Only) Table

GAME NAME	Nº of Flippers	FLIPPERS		FLIPPERS no E.O.S. Switch	
		SPI Nº / GAUGE-TURNS / Color		SPI Nº / GAUGE-TURNS / Color	
		LOWER LEFT	LOWER RIGHT	UPPER LEFT	UPPER RIGHT
Apollo 13	2	090-5032-0T 22-1080 -YEL-GRN-	SAME	Not Used	Not Used
Golden Eye	2	090-5032-0T 22-1080 -YEL-GRN-	SAME	Not Used	Not Used
Twister	2	090-5020-20T 22-900 -YELLOW-	090-5032-0T 22-1080 -YEL-GRN-	Not Used	Not Used
ID4: Independence Day	3	090-5032-0T 22-1080 -YEL-GRN-	SAME	Not Used	090-5020-30 23-900 -GREEN-
Space Jam †	2	090-5032-0T 22-1080 -YEL-GRN-	090-5020-20T 22-900 -YELLOW-	Not Used	Not Used
The Star Wars Trilogy - Special Edition †	2	090-5032-0T 22-1080 -YEL-GRN-	SAME	Not Used	Not Used
The Lost World: Jurassic Park †	2	090-5032-0T 22-1080 -YEL-GRN-	SAME	Not Used	Not Used
The X-Files †	2	090-5032-0T 22-1080 -YEL-GRN-	SAME	Not Used	Not Used
Starship Troopers †	3	090-5030-0T 23-1100 -ORANGE-	SAME	Not Used	090-5032-0T 22-1080 -YEL-GRN-
Viper Night Drivin' †	2	090-5030-0T 23-1100 -ORANGE-	SAME	Not Used	Not Used
Lost In Space †	2	090-5030-0T 23-1100 -ORANGE-	090-5032-0T 22-1080 -YEL-GRN-	Not Used	Not Used
Godzilla †	2	090-5032-0T 22-1080 -YEL-GRN-	SAME	Not Used	Not Used
South Park †	2	090-5030-0T 23-1100 -ORANGE-	SAME	Not Used	Not Used

† Coil Part Numbers ending with a "T" signifies the Diode is on the top of the lug (on the coil-winding side); Coil Part Numbers ending with a "B" signifies the Diode is on the bottom of the lugs.

Table continued on the next page.





APPENDIX E

Flipper Coil (White Star Board System* & S.A.M. System** Only) Table



GAME NAME	N ^o of Flippers	FLIPPERS w/E.O.S. Switch		FLIPPERS no E.O.S. Switch	
		SPI N ^o / GAUGE-TURNS / Color		SPI N ^o / GAUGE-TURNS / Color	
		LOWER LEFT	LOWER RIGHT	UPPER LEFT	UPPER RIGHT
Harley-Davidson® † and 1st through 3rd Editions	2	090-5032-0T 22-1080 -YEL-GRN-	090-5030-0T 23-1100 -ORANGE-	Not Used	Not Used
Striker Xtreme (NFL) †	3	090-5032-0T 22-1080 -YEL-GRN-	090-5030-0T 23-1100 -ORANGE-	090-5030-0T 23-1100 -ORANGE-	Not Used
Sharkey's Shootout †	3	090-5030-0T 23-1100 -ORANGE-	SAME	090-5030-0T 23-1100 -ORANGE-	Not Used
High Roller Casino †	2	090-5032-20T 22-900 -YELLOW-	090-5032-0T 22-1080 -YEL-GRN-	Not Used	Not Used
Austin Powers™ †	2	090-5020-30 23-900 -GREEN-	090-5030-0T 23-1100 -ORANGE-	Not Used	Not Used
MONOPOLY® †	3	090-5032-0T 22-1080 -YEL-GRN-	SAME	Not Used	090-5062-0T 23-1500 -BLUE-
Playboy †	2	090-5030-0T 23-1100 -ORANGE-	SAME	Not Used	Not Used
RollerCoaster Tycoon™ †	4	090-5032-0T 22-1080 -YEL-GRN-	SAME	090-5067-0T 25-1400 -RED-	090-5068-0T 25-1600 -WHITE-
The Simpsons™ Pinball Party †	6** (5 with Flipper Bats)	090-5032-0T 22-1080 -YEL-GRN-	SAME	Not Used	090-5030-0T 23-1100 -ORANGE-
		** The Homer Head Assembly is affixed to an Upr. Rt. Style Flipper (no E.O.S. Switch):		Flippers (Mini-Bats) on 2nd Level Playfield:	
			** 090-5020-20T 22-900 -YELLOW-	090-5041-00T 25-1800 -BLU-GRN-	090-5025-00 24-1570 -BLUE-
Terminator® 3: Rise of the Machines™ †	2	090-5032-0T 22-1080 -YEL-GRN-	SAME	Not Used	Not Used
The Lord of the Rings™ †	2	090-5020-20T 22-900 -YELLOW-	SAME	Not Used	Not Used
Ripley's Believe It or Not!® †	3	090-5032-0T 22-1080 -YEL-GRN-	SAME	Not Used	090-5067-00T 25-1400 -RED-
Elvis® †	4	090-5020-20T 22-900 -YELLOW-	SAME	090-5020-30 23-900 -GREEN-	SAME
The Sopranos™ †	2	090-5032-0T 22-1080 -YEL-GRN-	SAME	Not Used	Not Used
NASCAR® and [NDSE] †	2	090-5030-0T 23-1100 -ORANGE-	SAME	Not Used	Not Used
Grand Prix †	2	090-5030-0T 23-1100 -ORANGE-	SAME	Not Used	Not Used
† Coil Part Numbers ending with a "T" signifies the Diode is on the top of the lug (on the coil-winding side); Coil Part Numbers ending with a "B" signifies the Diode is on the bottom of the lugs.					
** S.A.M. System Games DO NOT REQUIRE DIODES. If you use a coil from your stock which has a diode, remove it ONLY FOR S.A.M. System Games.					
World Poker Tour™ (WPT)**	4	090-5032-ND 22-1080 [NO DIODE]	SAME	090-5030-ND 23-1100 [NO DIODE]	SAME
©Disney's Pirates of the Caribbean**	2	090-5030-ND 23-1100 [NO DIODE]	SAME	Not Used	Not Used
Family Guy™ **	3 Norm.	090-5030-ND 23-1100 [NO DIODE]	SAME	090-5062-ND 23-1500 [NO DIODE]	Not Used
	2 Mini	090-5046-01-ND 27-950 [NO DIODE]	SAME		
Spider-Man™ **	3	090-5032-ND 22-1080 [NO DIODE]	SAME	Not Used	090-5032-ND 22-1080 [NO DIODE]



APPENDIX E

Generic Coil Cross-Reference Guide † ‡

Flipper Coil Table † ††

GAME NAME	Nº of Flippers	FLIPPERS w/E.O.S. Switch		FLIPPERS no E.O.S. Switch	
		SPI Nº / GAUGE-TURNS / Color		SPI Nº / GAUGE-TURNS / Color	
		LOWER LEFT	LOWER RIGHT	UPPER LEFT	UPPER RIGHT
Laser War ‡	2	090-5011-00 22-750 / 30-2600	SAME	Not Used	Not Used
Secret Service ‡	3	090-5006-00 23-620 / 30-2600	SAME	Not Used	090-5006-00 23-620 / 30-2600
Torpedo Alley ‡	3	090-5011-00 22-750 / 30-2600	090-5013-00 23-700 / 30-2600	Not Used	090-5012-00 23-800 / 30-2600
Time Machine ‡	2	090-5011-00 22-750 / 30-2600	SAME	Not Used	Not Used
<small>‡ These coils are dual-wound.</small>					
Playboy 35th Anniversary ††	2	090-5020-02 22-900 -YEL-YEL-	SAME	Not Used	Not Used
ABC Monday Night Football ††	2	090-5020-02 22-900 -YEL-YEL-	SAME	Not Used	Not Used
<small>†† A very small % of these games used a 090-5020-20 coil which used a proto-type Solid State Flipper System. The two types of coils both are 22-900 coils; the only difference is the addition of the 1N5404 Diode on the (-02) coils which was used in the Deger Design.</small>					
Robocop	2	090-5020-20 22-900 -YEL-YEL-	SAME	Not Used	Not Used
Phantom of the Opera	2	090-5020-20 22-900 -YEL-YEL-	SAME	Not Used	Not Used
Back to the Future	2	090-5020-20 22-900 -YEL-YEL-	SAME	Not Used	Not Used
The Simpsons	2	090-5020-20 22-900 -YEL-YEL-	SAME	Not Used	Not Used
Checkpoint	2	090-5020-20 22-900 -YEL-YEL-	SAME	Not Used	Not Used
Teenage Mutant Ninja Turtles	2	090-5020-30 23-900 -GRN-GRN-	SAME	Not Used	Not Used
Batman	2	090-5020-30 23-900 -GRN-GRN-	SAME	Not Used	Not Used
Star Trek 25th Anniversary	2	090-5020-30 23-900 -GRN-GRN-	SAME	Not Used	Not Used
Hook	2	090-5030-00 23-1100 -ORG-ORG-	090-5020-30 23-900 -GRN-GRN-	Not Used	Not Used
Lethal Weapon 3	2	090-5030-00 23-1100 -ORG-ORG-	SAME	Not Used	Not Used
Star Wars	2	090-5032-00 22-1080 -YEL-GRN-	SAME	Not Used	Not Used
Rocky & Bullwinkle & Friends	2	090-5020-30 23-900 -GRN-GRN-	SAME	Not Used	Not Used
Jurassic Park	3	090-5020-30 23-900 -GRN-GRN-	SAME	Not Used	090-5030-00 23-1100 -ORG-ORG-

Table continued on the next page.



APPENDIX E

Flipper Coil Table †

GAME NAME	N ^o of Flippers	FLIPPERS w/ E.O.S. Switch		FLIPPERS no E.O.S. Switch	
		SPI N ^o / GAUGE-TURNS / Color		SPI N ^o / GAUGE-TURNS / Color	
		LOWER LEFT	LOWER RIGHT	UPPER LEFT	UPPER RIGHT
Last Action Hero	2	090-5020-30 23-900 -GRN-GRN-	SAME	Not Used	Not Used
Tales from the Crypt	3	090-5032-00 22-1080 -YEL-GRN-	SAME	Not Used	090-5041-00 25-1800 -BLU-GRN-
The Who's Tommy	3	090-5020-30 23-900 -GRN-GRN-	SAME	090-5041-00 25-1800 -BLU-GRN-	Not Used
WWF Royal Rumble	4	090-5032-00 22-1080 -YEL-GRN-	SAME	090-5041-00 25-1800 -BLU-GRN-	SAME
Guns N' Roses	3	090-5032-00 22-1080 -YEL-GRN-	SAME	090-5030-00 23-1100 -ORG-ORG-	Not Used
Maverick	3	090-5032-00 22-1080 -YEL-GRN-	SAME	Not Used	090-5032-00 22-1080 -YEL-GRN-
Mary Shelley's Frankenstein	3	090-5030-00 23-1100 -ORG-ORG-	SAME	Not Used	090-5030-00 23-1100 -ORG-ORG-
Baywatch	4	090-5030-00 23-1100 -ORG-ORG-	090-5020-30 23-900 -GRN-GRN-	090-5025-00 24-1570 -See Note-	090-5030-00 23-1100 -ORG-ORG-
Batman Forever	3	090-5032-00 22-1080 -YEL-GRN-	090-5020-20 22-900 -YEL-YEL-	Not Used	090-5020-30 23-900 -GRN-GRN-
Apollo 13	2	090-5032-00 22-1080 -YEL-GRN-	SAME	Not Used	Not Used
Golden Eye	2	090-5032-00 22-1080 -YEL-GRN-	SAME	Not Used	Not Used
Twister	2	090-5020-20 22-900 -YEL-YEL-	090-5032-00 22-1080 -YEL-GRN-	Not Used	Not Used
ID4: Independence Day	3	090-5032-00 22-1080 -YEL-GRN-	SAME	Not Used	090-5020-30 23-900 -GRN-GRN-
Space Jam †	2	090-5032-00T 22-1080 -YEL-GRN-	090-5020-20T 22-900 -YEL-YEL-	Not Used	Not Used
The Star Wars Trilogy - Special Edition †	2	090-5032-00T 22-1080 -YEL-GRN-	SAME	Not Used	Not Used
The Lost World: Jurassic Park †	2	090-5032-00T 22-1080 -YEL-GRN-	SAME	Not Used	Not Used
The X-Files †	2	090-5032-00T 22-1080 -YEL-GRN-	SAME	Not Used	Not Used
Starship Troopers †	3	090-5030-00T 23-1100 -ORG-ORG-	SAME	Not Used	090-5032-00T 22-1080 -YEL-GRN-
Viper Night Drivin' †	2	090-5030-00T 23-1100 -ORG-ORG-	SAME	Not Used	Not Used
Lost In Space †	2	090-5030-00T 23-1100 -ORG-ORG-	090-5032-00T 22-1080 -YEL-GRN-	Not Used	Not Used
Godzilla †	2	090-5032-00T 22-1080 -YEL-GRN-	SAME	Not Used	Not Used
South Park †	2	090-5030-00T 23-1100 -ORG-ORG-	SAME	Not Used	Not Used
Harley-Davidson® † and Harley-Davidson® 2nd Ed. †	2	090-5032-00T 22-1080 -YEL-GRN-	090-5030-00T 23-1100 -ORG-ORG-	Not Used	Not Used
Striker Xtreme (NFL) †	3	090-5032-00T 22-1080 -YEL-GRN-	090-5030-00T 23-1100 -ORG-ORG-	090-5030-00T 23-1100 -ORG-ORG-	Not Used
Sharkey's Shootout †	3	090-5030-00T 23-1100 -ORG-ORG-	SAME	090-5030-00T 23-1100 -ORG-ORG-	Not Used
High Roller Casino †	2	090-5020-20T 22-900 -YEL-YEL-	090-5032-00T 23-1080 -YEL-GRN-	Not Used	Not Used
Austin Powers™ †	2	090-5020-30 23-900 -GRN-GRN-	090-5030-00T 23-1100 -ORG-ORG-	Not Used	Not Used
MONOPOLY® †	3	090-5032-00T 22-1080 -YEL-GRN-	SAME	Not Used	090-5062-00T 23-1500 -BLU-BLU-
Playboy †	2	090-5030-00T 23-1100 -ORG-ORG-	SAME	Not Used	Not Used
RollerCoaster Tycoon™ †	4	090-5032-00T 22-1080 -YEL-GRN-	SAME	090-5067-00T 25-1400 -RED-RED-	090-5068-00T 25-1600 -WHT-WHT
The Simpsons™ Pinball Party †	6* (5 with Flipper Bats)	090-5032-00T 22-1080 -YEL-GRN-	SAME	Not Used	090-5030-00T 23-1100 -ORG-ORG-
		* The Homer Head Assembly is affixed to an Upr. Rt. Style Flipper (no E.O.S. Switch):		Flippers (Mini-Bats) on 2nd Level Playfield:	
			* 090-5020-20T 22-900 -YEL-YEL-	090-5041-00T 25-1800 -BLU-GRN-	090-5025-00T 24-1570 -See Note-
Terminator® 3: Rise of the Machines™ †	2	090-5032-00T 22-1080 -YEL-GRN-	SAME	Not Used	Not Used
The Lord of the Rings™ †	2	090-5020-20T 22-900 -YEL-YEL-	SAME	Not Used	Not Used
Ripley's Believe It or Not!® †	3	090-5032-00T 22-1080 -YEL-GRN-	SAME	Not Used	090-5067-00T 25-1400 -RED-RED-

† Coil Part N^os ending with a "T" signifies the Diode is on the top of the lug (on the coil-winding side); Coil Part N^os ending with a "B" signifies the Diode is on the bottom of the lugs.



APPENDIX F

Motor Specification (White Star Board System* Only) Table



Game Name	Function	Specifications	Part Number
Apollo 13	Rocket Up/Down Movement	Bowman Motor 24VAC 60Hz 3W 6 RPM CCW	515-6383-00 <i>incl. Connector</i>
	Moon Unit Rotational Orbit	Multi Products Motor 24VAC 50/60Hz 3W 6 RPM CCW	515-6487-00 <i>incl. Connector</i>
	Shaker	Johnson Motor (Vibrator) 10.5VDC 10 AMP 2950 RPM CW	041-5029-00 MOTOR ONLY
Golden Eye	Satellite Left/Right Movement	Bowman Motor 24VAC 60Hz 3W 6 RPM CW	515-6528-00 <i>incl. Connector</i>
Twister	Spinning Disc with Magnet	Multi Products Motor 24VAC (041-5026-00) 50/60Hz 3W 325 RPM CCW	515-6347-00 <i>incl. Connector</i>
	Backbox Fan (Tornado Wind)	Multi Products Motor 24VAC (041-5052-00) 50/60Hz 3W 3600 RPM CW	515-6531-00 <i>incl. Connector</i>
ID4: Independence Day	Alien Head Open/Close Movement	Servo Motor (94322)	041-5045-00 MOTOR ONLY
<i>SPACE JAM (NO MOTOR USED)</i>			
The Star Wars Trilogy - S.E.	X-Wing Left/Right Movement	Bowman Motor 24VAC (041-5058-00) 60Hz 3W 10 RPM CCW	515-6383-01 <i>incl. Connector</i>
The Lost World: Jurassic Park	Snagger & Center Link Lift Up/Down Movement	Multi Products Motor 20VDC (041-5059-03) 9 RPM Non-Directional	515-6715-03 <i>incl. Connector</i>
	Shaker	Johnson Motor (Vibrator) 10.5VDC 10 AMP 2950 RPM CW	041-5029-00 MOTOR ONLY
The X-Files	X-File Cabinet Lift Up/Down Movement	Multi Products Motor 20VDC 9 RPM CCW	041-5057-00 MOTOR ONLY
Starship Troopers	Warrior Bug Forward/Reverse Movement	Haydon Switch & Instrument, Inc. Stepper Motor 12VDC 4.6W (041-5062-00), Series 36000: 1.4"ø (Non-Captive Shaft not included) HSI #36864-12 (Unipolar) Travel per Step: .004 Step Angle: 15°	515-6794-00 <i>incl. Connector</i> Requires 7" Shaft: 530-5503-00
<i>VIPER NIGHT DRIVIN' (NO MOTOR USED)</i>			
Lost In Space	Spinning Disc with Magnet	Multi Products Motor 24VAC (041-5046-00) 50/60Hz 3W 325 RPM CCW	515-6347-00 <i>incl. Connector</i>
Godzilla	Shaker ‡	Multi #3811 0630 Motor (Vibrator) 12VDC 3100 RPM CW (w/DRL PTS) ‡	041-5029-01 MOTOR ONLY
<i>SOUTH PARK (NO MOTOR USED)</i>			
Harley-Davidson® 1st through 3rd Editions	Shaker ‡	Multi #3811 0630 Motor (Vibrator) 12VDC 3100 RPM CW (w/DRL PTS) ‡	041-5029-01 MOTOR ONLY
	Motorcycle Lift Up/Down Movement	Autotrol 24VAC (041-5072-02) 20 RPM CCW	515-7025-00 <i>incl. Connector</i>
Striker Xtreme (NFL)	Goalie (Linebacker) Left to Right Movement	Multi #3590 12VDC (041-5075-00) 60 RPM	515-7071-00 <i>incl. Connector</i>
Sharkey's Shootout	Mystery Ball Rotating Movement	Hankscraft Motor Model-E 24VAC (041-5076-00) 50/60Hz 3W 20 RPM CW	515-7095-00 <i>incl. Connector</i>
High Roller Casino	Roulette Wheel Rotating Movement	Multi Products Motor 20VDC (041-5078-00) 17 RPM CCW	515-7153-00 <i>incl. Connector</i>
	Up/Dn. Ramp in Slot Mach. Lift Up/Down Movement	Haydon Switch & Instrument, Inc. Stepper Motor 12VDC 4.6W (041-5062-00), Series 36000: 1.4"ø (Non-Captive Shaft not included) HSI #36864-12 (Unipolar) Travel per Step: .004 Step Angle: 15°	515-6794-00 <i>incl. Connector</i> Requires Shaft 4¼": 530-5503-01
Austin Powers™	Time Machine Rotating Movement	Multi Products Motor 24VAC (041-5079-00) 50/60Hz 20RPM CCW	515-7141-00 <i>incl. Connector</i>
	Laser Beam Left to Right Directional	Autotrol Motor 24VAC (041-5081-00) 50/60Hz 4W 10RPM Bi-Directional	515-7171-00 <i>incl. Connector</i>
	Dr. Evil Target Lift Up/Down Movement	Hankscraft Motor Model-E 24VAC (041-5030-00) 50/60Hz 6RPM CCW	515-5900-00 <i>incl. Connector</i>
Monopoly®	Mini-Flipper (Waterworks) Rotating Movement	Multi Prod. Motor & Gear Box #7000 EX00159A 20VDC 50/60Hz 85RPM CC/CCW	041-5083-00 MOTOR ONLY
Playboy	Triangular Billboard Rotating Movement	Autotrol Motor (BD511 150-1387) 24VAC 50/60Hz 12RPM Bi-Directional	041-5086-02 MOTOR ONLY
	Centerfold Mechanism Open/Close Movement	Multi Products (3680) Motor 12v DC 10/12 RPM CC/CCW	041-5075-04 MOTOR ONLY
	Tease Drop Screen Lift Up/Down Movement	Haydon Switch & Instrument, Inc. Stepper Motor 12VDC 4.6W (041-5062-00), Series 36000: 1.4"ø (Non-Captive Shaft not included) HSI #36864-12 (Unipolar) Travel per Step: .004 Step Angle: 15°	515-6794-00 <i>incl. Connector</i> Requires 7" Shaft: 530-5503-00

‡ Please Note: ".01" Shaker Motor is **Not Compatible** with old Shaker Motor 041-5029-00 (Shaker Motor Assy. 515-5893-00). THIS NEW MOTOR CAN ONLY BE USED IN NEW SHAKER MOTOR ASSY. 515-5893-01.

Table continued on the next page.





APPENDIX F

Motor Specification (White Star Board System* & S.A.M. System** Only) Table



Game Name	Function	Specifications	Part Number
ROLLERCOASTER TYCOON™ (NO MOTOR USED)			
THE SIMPSONS™ PINBALL PARTY (NO MOTOR USED)			
Terminator® 3: Rise of the Machines™	Backbox Ball Shooter Up/Down Movement	Multi Products Motor 24VAC (041-5079-01) 21 RPM CW	515-7317-00 <i>incl. Connector</i>
The Lord of the Rings™	Balrog (Motor & Gate) Open/Close Movement	Multi Prod. Motor 20VDC Series 600B (or equiv.) 50/60Hz 10 RPM Bi-Directional	041-5088-01 MOTOR ONLY
RIPLEY'S BELIEVE IT OR NOT!® (NO MOTOR USED)			
Elvis®	Elvis™ Front/Back Movement	Haydon Switch & Instrument, Inc. Stepper Motor 12VDC 10W (041-5089-00), (Non-Captive Shaft not included) HSI #46868-12-002	500-6809-00 <i>incl. Connector</i> Requires 7.25" Shaft: 530-5658-00
	▶▶▶ OPTIONAL ◀◀◀ Shaker	Multi #3811 0630 Motor (Vibrator) 12VDC (041-5029-01) 3100 RPM (w/DRL PTS)	515-5893-01 <i>incl. Connector</i>
The Sopranos™	Bada Bing! Girls x2 Rotating Posts Movement	Autotrol Synchronous Motor 24VAC 4W 50/60Hz 45.7/54.9 RPM Bi-Directional	041-5092-00 <i>w/1" Shaft + 12" Leads</i>
NASCAR® and [NDSE]	Back Panel Rotating (Car) Windmill (Skill Ball Enter)	Multi Products Motor & Gear Box 20VDC Model #8000 (EX-04-073) 10 RPM	041-5093-00 MOTOR ONLY
Grand Prix	Back Panel Rotating (Car) Windmill (Skill Ball Enter)	Multi Products Motor & Gear Box 20VDC Model #8000 (EX-04-073) 10 RPM	041-5093-00 MOTOR ONLY
World Poker Tour™ (WPT) (NO MOTOR USED)			
The Simpsons™ Kooky Carnival	Bart on Skateboard Left/Right Movement	Multi Products Motor with Crank 24VAC (041-5095-01) 50/60Hz 3W 14 RPM	500-6947-01 <i>incl. Connector</i>
	Left & Right Ramps Up/Down Movement	Multi Products Motor 24VAC (041-5048-01) 50/60Hz 3W 15 RPM CCW (Qty. 2 in game)	515-7558-00 <i>incl. Connector</i>
	Shaker <i>(details in SKC Manual, Page 24)</i>	Multi #3811 0630 Motor (Vibrator) 12VDC 3100 RPM (w/DRL PTS)	041-5029-01 MOTOR ONLY
©Disney's Pirates of the Caribbean	Spinning Disk	Multi #3811R 0630 Motor (Vibrator) 12VDC (041-5029-04) 3100 RPM (w/DRL PTS) -04 is RoHS compliant; can substitute with -01 domestic	511-5024-04 <i>incl. Connector</i>
	Pirate Ship Sinking/Raising Movement	Multi Products Motor & Gear Box 24VDC Model #7000-DCM 12 RPM	041-5101-00 MOTOR ONLY
Family Guy™	Stewie Figurine Left & Right Movement	Stepper Motor NPM PF35T-48D4STD 5V RVB (041-5102-00 Reference Only)	511-5043-00 <i>incl. Connector</i>
Spider-Man™	Doc Ock, Sandman & 3-Bank Up/Down Movement	Sync. Motor 24VAC 50/60Hz 3W 12 RPM CW (041-5103-00 Reference Only)	511-5063-00 <i>incl. Connector</i>
	▶▶▶ OPTIONAL ◀◀◀ Shaker Motor Kit 502-5027-00	Multi #3811R 0630 Motor (Vibrator) 12VDC (041-5029-04) 3100 RPM (w/DRL PTS) -04 is RoHS compliant; can substitute with -01 domestic	515-5893-01 <i>incl. Connector</i>



APPENDIX F

Motor Specification Table

The following table only list games that used motors. Part Numbers starting with "515-" will include the Wiring Harness & Connector.

Game Name	Function	Specifications	Part N ^o
ABC Monday Night Football	Goal Post Up/Down Movement	Motor 24v A.C. 60 RPM CW	515-5222-00
Phantom of the Opera	Organ Up/Down Movement	Bowman Motor 24v 60Hz 3W 11 RPM CCW	515-5256-00
Checkpoint	Mag Wheel (in Backbox)	Motor D.C. (KEN)	041-5005-00
	Shaker	Johnson Motor (Vibrator)	041-5002-00
Teenage Mutant Ninja Turtles	Spinning Pizza Ball Deflector	Gear Motor 24v A.C. 325 RPM CW	515-5397-00
Batman	Bar Target Up/Down Movement	Bowman Motor 24v 60Hz 3W 11 RPM CCW	515-5256-00
Star Trek 25th Anniversary	Swinging Target	Bowman Motor 24v 22½ RPM	515-5534-00
	Transporter F/X	Gear Motor 24v A.C. 3½ RPM	500-5421-00
	Cooling Fan (for Transporter F/X)	4½" Motor 12v	041-5014-00
Lethal Weapon 3	Spinning Light	Motor 2½ v A.C. 4000 RPM CCW	041-5017-00
Star Wars	Bar Target Up/Down Movement	Bowman Motor 24v 60hz 3W 11 RPM CCW	515-5256-00
	R2D2 Robot Left/Right Movement	Bowman Motor 24v A.C. 22½ RPM CW	515-5571-00
	Death Star Rotation	Bowman "G" Motor 24v A.C. 60Hz 6 RPM CW	515-5570-00
Rocky & Bullwinkle & Friends	Nell Log "Cutting Blade" Forward/Back Movement	Autotrol Model E Motor 24v 60hz 4W 3 RPM CCW	041-5023-00
Jurassic Park	T-Rex Left/Right Movement	Multi Motor 5v D.C.	041-5025-00
	T-Rex Up/Down Movement	Bowman Motor 24v 11 RPM CW	041-5026-00
	Shaker	Johnson Motor (Vibrator)	041-5002-00
Last Action Hero	Crane Left/Right Movement	Multi Products Motor 12v D.C. #3312 OSC	041-5027-00
	Shaker	Johnson Motor (Vibrator) 10.5v D.C. 10 AMP 2950 RPM CW	041-5029-00
Tales from the Crypt	Tombstone Up/Down Movement	Bowman Motor 24v A.C. 6 RPM CCW	515-5900-00
	Shaker	Johnson Motor (Vibrator) 10.5v D.C. 10 AMP 2950 RPM CW	041-5029-00
The Who's Tommy	Mirror Up/Down Movement	Bowman Motor 24v A.C. 6 RPM CCW	515-5900-00
	Flipper Blinders	Servo Motor (94102)	041-5032-00
	Spinning Airplane Propellers	Motor D.C.	041-5033-00
WWF Royal Rumble	Shaker	Johnson Motor (Vibrator) 10.5v D.C. 10 AMP 2950 RPM CW	041-5029-00
Maverick, The Movie	Turning Paddle Wheel	Motor 24v A.C. 10 RPM	041-5036-00
Mary Shelley's Frankenstein	Creature Head Left/Right Movement	Servo Motor (94102)	041-5032-00
Batman Forever	Cannon Left/Right Movement	Bowman Motor 24v A.C. 60Hz 3W 6 RPM CCW	515-6383-00

APPENDIX G

Part Number Prefix Classification Codes

I. Electrical Source, Energy & Signal Converters

- 010- Transformers
- 031- Speakers
- 090- Solenoids (Coils)
- 150- Filters, Outlets, Varistors, Thermistors
- 200- Fuses

II. Conductors, Connectors & Insulators

- 034- Line Cords
- 036- Cable Assemblies & Wiring Harnesses
- 041- Motors
- 045- Connectors (All Types)
- 055- Lugs (M/F), Pins (M/F), Discs, Ring Terminals, Terminal Strips, etc.
- 060- Polarizing Keys and Conn. Covers
- 077- Lamp Sockets

III. Circuits & Circuit Elements

- 100- ICs
- 110- Transistors
- 112- Diodes (All Types including LEDs & Modules)
- 121- Resistors
- 123- Resistors (Variable & Adjustable)
- 124- Regulators & Bridge Rectifiers
- 125- Capacitors (Radial Lytics & Ferrites)
- 126- Piezo Crystal
- 127- Heatsinks
- 130- Capacitors (Tectates & Ceramics)
- 140- Oscillators (Clocks/Crystals)
- 165- Light Bulbs
- 180- Switches
- 181- Switch Membranes (Pads) & Piezo Sensors
- 190- Relays
- 960- EPROM (*Raw Part*)
- 965- EPROM (*Programmed Part*)

IV. Bolts, Screws, Nuts, Washers & Nails

- 231- Bolts
- 232- Screws (Pan Head)
- 234- Screws (HWH)
- 237- Screws (Misc.)
- 240- Nuts (Misc.)
- 242- Washers (Flat, Round)
- 244- Washers (Split Lock)
- 245- Nyloners
- 246- Washers (Lockers, External Tooth)
- 281- Nails

V. Mechanical Components

- 249- Rivets
- 251- Pins (Dowel), Finishing Nails, Hairpins, Spring Pins and Clevis Pins
- 254- Stand-Offs, Spacers and Shims
- 260- Steel Ball (All Types Steel, Glowing, Delrin, etc.)
- 265- Springs (Extension)
- 266- Springs (Compression)
- 267- Springs (Torsion)
- 269- Springs (Washers - Belleville, Wave)
- 270- Retaining Rings
- 280- Grommets, Bushings and Nyloners
- 283- Bearings

VI. Handles, Locks, Catches, Latches, Keys

- 355- Handles, Locks, Catches, Latches and Keys

VII. Fabricated Parts

- 390- Hinges
- 501- Coin Doors
- 515- Sub-Assemblies
- 520- Printed Circuit Boards (PCBs)
- 522- Display Glass
- 525- Wood Parts
- 530- Screw Machined Parts
- 535- Fabricated Parts
- 545- Molded (Extruded) Plastic and Rubber Parts (Rings, Sleeves, etc.)
- 550- Molded (Inserts)

VIII. In-House Assemblies

- 500- End Product (Systems and Models)
 - 502- Kits (Created In-House)
 - 505- Cabinets (complete)
 - 510- Riveted Sub-Assemblies (In-House)
 - 511- Sub-Assemblies (In-House)
 - 515- Sub-Assemblies*
- *2 or more 515-'s but still a sub-assembly.

IX. Bulk Materials

- 600- Braided Wire & Ground Straps
- 601- Stranded Wire
- 602- Ribbon Cable
- 604- Telephone Line Cord
- 605- Sleeving (Shrink Tubing)
- 625- Velcro (non-adhesive)
- 626- Foam Rubber, Foam Pads, Rubber Bumpers (Blue Pads), Tape (All Types) Velcro (adhesive) and String / Rope

















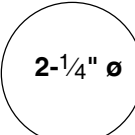
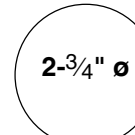



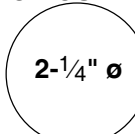
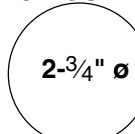

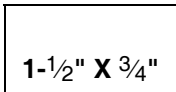
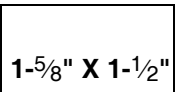
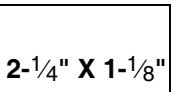
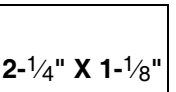
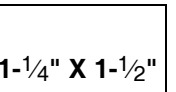
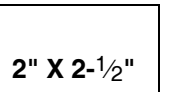

X. Miscellaneous

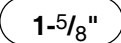
- 000- Tools (*see also 777-*) and Supplies
- 040- Clamps, Ties & Clips
- 042- Pulleys
- 091- Coin Mechs
- 205- Fuse Holders
- 631- Staples
- 660- Glass (Playfield, Backglass, etc.)
- 675- Cleaners
- 705- Packing & Shipping Items
- 755- Instruction, Coin Cards, Ins. Sheets
- 756- Information Sheets, Service Bulletins, Instruction Sheets in Kits and Templates
- 777- Tools (Wrenches and Drivers)
- 780- Manuals
- 802- Decal Kits (comprised of 820's)
- 820- Decals, Mylar and Labels (Sheets/Sets)
- 803- Plastic Kits (comprised of 830's)
- 830- Plastic Pieces (Butyrate Sheets/Sets)
- 880- Toys, Models, Figurines, etc.
- 900- Game Posters

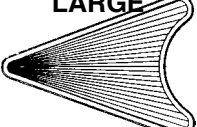

APPENDIX H

Playfield Inserts (Plastic Light Covers)

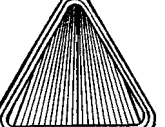
Patterns: STARBURST  STIPPLE 	STARBURST CIRCULAR  550-5000-XX	STARBURST CIRCULAR  550-5001-XX	STARBURST CIRCULAR  550-5002-XX	STARBURST CIRCULAR  550-5003-XX	STARBURST CIRCULAR  550-5004-XX
STARBURST CIRCULAR  550-5005-XX	STARBURST CIRCULAR  550-5006-XX	PLAIN CIRCULAR  550-5007-XX	PLAIN CIRCULAR  550-5008-XX	PLAIN CIRCULAR  550-5009-XX	PLAIN CIRCULAR  550-5010-XX
PLAIN CIRCULAR  550-5011-XX	PLAIN CIRCULAR  550-5012-XX	STIPPLE CIRCULAR  550-5048-XX	STIPPLE 1" SQUARE  550-5019-XX	ROLLOVER BUTTON BASE  550-5026-XX	WHITE STAR (only in white)  545-5015-00
STIPPLE RECTANGULAR  550-5018-XX	STIPPLE RECTANGULAR  550-5051-XX	STARBURST RECTANGULAR  550-5044-XX	PLAIN RECTANGULAR  550-5049-XX	PLAIN RECTANGULAR  550-5050-XX	PLAIN RECTANGULAR  550-5063-XX
STARBURST MINI SHIELD  550-5024-XX	STARBURST LARGE SHIELD  550-5025-XX	MINI HOT DOG  550-5020-XX	BEVEL HOT DOG  550-5021-XX	PLAIN HOT DOG  550-5022-XX	BANANA  550-5023-XX
STARBURST ARROW-SMALL  550-5013-XX	STARBURST ARROW-LARGE  550-5070-XX	STARBURST ARROW-HEAD SMALL  550-5014-XX	STARBURST ARROW-HEAD LARGE  550-5015-XX	STARBURST BULLET  550-5016-XX	STARBURST TRIANGLE  550-5017-XX

Note: The shapes and sizes shown above are not to scale. Some shapes may no longer be available in every color.

Instructions: Parts which may come in various colors (i.e. targets, some posts, playfield inserts, etc.) end in a 2-digit number which correspond to the color of that part. The "-XX" in part number which may come in various colors should be replaced with the desired 2-Digit number corresponding to the color desired below. *Not all colors may be available.*

PLASTIC PART COLOR CHART											
Nº	Color	Nº	Color	Nº	Color	Nº	Color	Nº	Color	Nº	Color
-00	Black or Solid Clear	-03	Amber	-06	Yellow	-09	Purple	-12	Fluor. Blue	-15	Luminescent
-01	Clear	-04	Green	-07	Orange	-10	Fluor. Orange	-13	Teal Green	-16	Gold
-02	Red	-05	Blue	-08	White	-11	Fluor. Green	-14	Gray	-17	Trans. Brown

APPENDIX I

Anti-Loft Stand-Up Targets



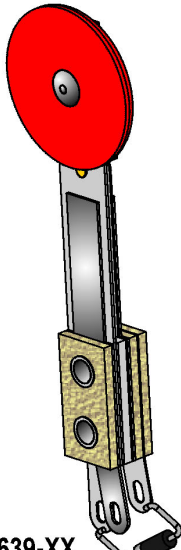

515-7639-XX
1" Ø ROUND
ANTI-LOFT STAND-UP
SWITCH & TARGET
RIVETED ASSEMBLY*

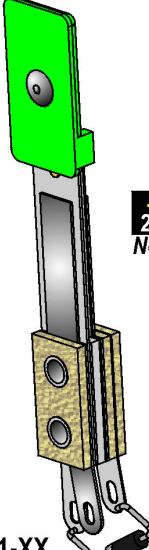

515-7581-XX
1" X 1/2" NARROW RECTANGLE
ANTI-LOFT STAND-UP
SWITCH & TARGET
RIVETED ASSEMBLY*

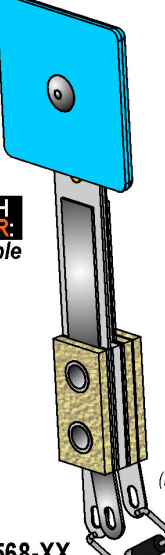

515-7568-XX
1" X 1" SQUARE
ANTI-LOFT STAND-UP
SWITCH & TARGET
RIVETED ASSEMBLY*

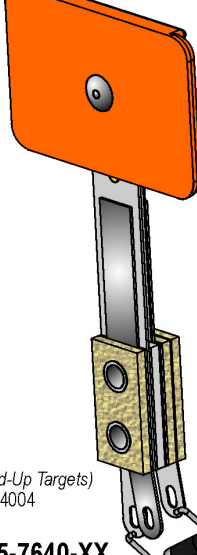

515-7640-XX
1" X 1-1/2" WIDE RECTANGLE
ANTI-LOFT STAND-UP
SWITCH & TARGET
RIVETED ASSEMBLY*

Ordering Note:
-XX REPLACE WITH
2-DIGIT FOR COLOR:
Not all colors available
(colors shown not exact)

-02	Red
-03	Amber
-04	Green
-05	Blue
-06	Yellow
-07	Orange
-08	White

(Required on all Stand-Up Targets)
▼ Switch Diode, 1N4004
112-5003-00

*Some targets may require the lugs position be changed to the left or to the right, depending on the application; these targets will have a different part number and are called out in the game manual they are used in (see Section 4, Chapter 1, Parts Identification & Location, Playfield... -Switches.) Review the game manual for the game desired for the original target used or application.

For Anti-Loft Application use
Large Foam Pad,
5/8" X 7/16" X 3/16" Thick
626-5078-00

For > Light < Anti-Loft Application use
Small Foam Pad,
7/16" X 7/16" X 1/8" Thick
626-5029-00

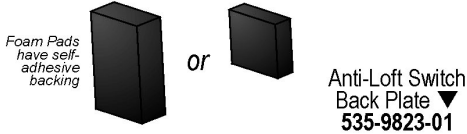

ASM. REF. IN-HOUSE USE ONLY:
Light Anti-Loft Stand-Up Target Assemblies which includes the Anti-Loft Switch Back Plate, Switch Mounting Bracket and Foam Pad (Small): 500-5835-XX (ROUND), 500-5857-XX (NARROW), 500-5232-XX (SQUARE) and 500-5321-XX (RECTANGLE).

Anti-Loft Stand-Up Target Assemblies which includes the Anti-Loft Switch Back Plate, Switch Mounting Bracket and Foam Pad (Large): 500-7062-XX (ROUND), 500-6985-XX (NARROW), 500-6984-XX (SQUARE) and 500-7063-XX (RECTANGLE).

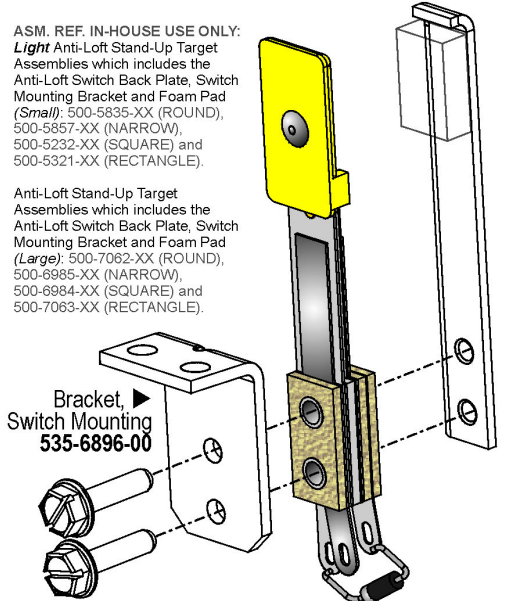

▲ #6-32 X 5/8" Slotted HWH Swage (Zinc) Screws (Qty. 2/per) **237-5976-04**

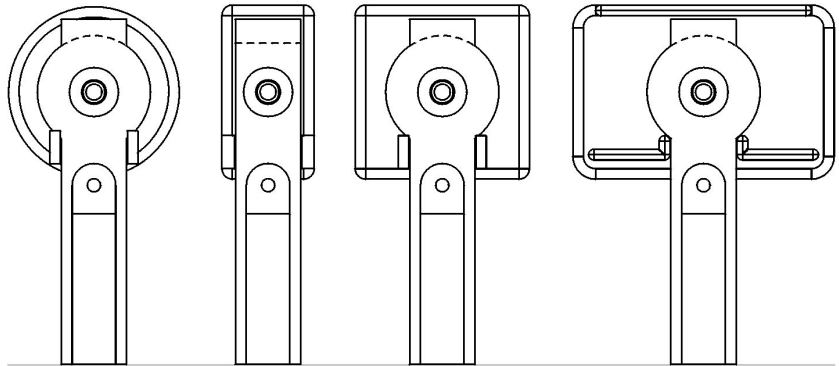

REAR VIEWS OF ANTI-LOFT TARGET & SWITCH ASSEMBLIES

The material of the Anti-Loft Switch has been extended higher to be used with the Anti-Loft Switch Back Plate. **IMPORTANT:** Switch & Target Assemblies (X) without the extension (the predecessors) **SHOULD NOT** be used with an Anti-Loft Switch Back Plate (shown left).

APPENDIX REFERENCE FOR PINBALL GAMES WHICH USED THE BELOW SWITCH & TARGET ASSEMBLIES NOTE:

The Switch & Target Assemblies (X) without the extension have the following part numbers*: 515-5966-XX (Round), 515-5967-XX (Narrow), 515-5162-XX (Square) and 515-6027-XX (Rectangle) and should only be used with the Switch Back Plate (shown right), 535-6452-00 and Small Foam Pad, 626-5029-00.

* If the above referenced part numbers are no longer available from the factory or your distributor, it will be substituted with the appropriate Anti-Loft counterpart. Not all colors may be available.

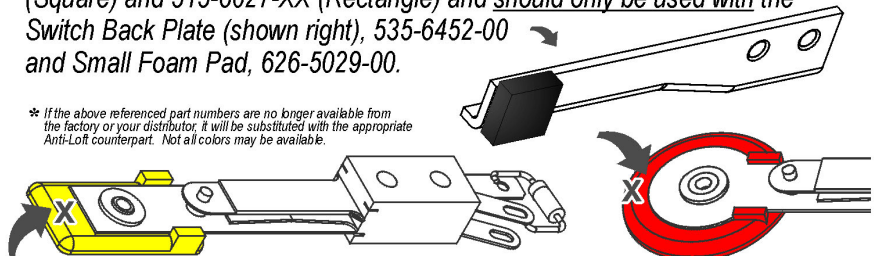

APPENDIX I

Modular Stand-Up Targets

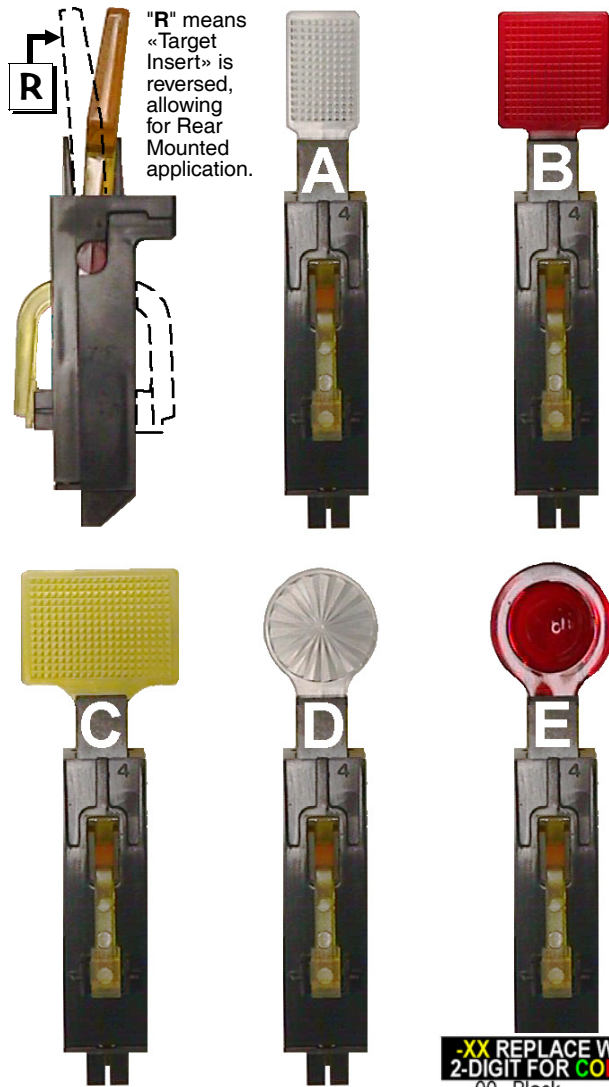

"R" means «Target Insert» is reversed, allowing for Rear Mounted application.

To Replace the « Target Insert » or change Target Orientation :

Items A-E Note: For the Target Assembly use the "500-" SPI Part Number(s) shown in the Parts Table below. To receive the Target Assembly with the « Target Insert » « Reversed » simply add a "R" at the end of the Part Number. See Side View picture left to compare (dashed line shows target reversed). For just the «Target Insert» use the "545-" SPI Part Number.



To reverse it yourself or to just change the insert:

1. With a small flat head screwdriver, push into the small tab at the bottom of the target front and give a slight twist motion to "pop" the two halves.

2. Push the Target Insert bottom in at the same time while you slide the top (front) part up, then let go of the insert as the two halves come apart.

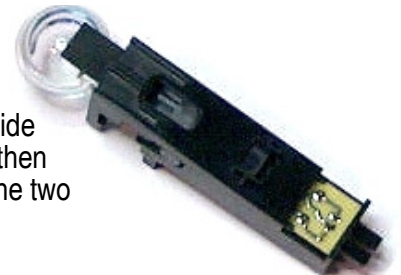

3. Replace target or reinsert it into the other size while sliding the two halves back together.

Note: If you were reversing the orientation, don't forget to also turn the Switch Actuator PCB 180°. Test Switch.

Take Note:

- Items A-E come in various colors. These targets may not be available in every color. The "-XX" in should be replaced with the desired 2-Digit number for the color desired as described in the Color Chart below. As of print date, the following colors were used :
 -01 Clear (A, D); -02 Red (A, B, C, D, E); -03 Amber (D, E);
 -04 Green (A, B); -05 Blue (C); -06 Yellow (A, C),
 -09 Purple (B, D); -11 Fluorescent Green (A, B, D)
- For location(s) and type of Stand-Up Targets used, if any, see Section 4, Chapter 1, Parts Identification & Location.

-XX REPLACE WITH 2-DIGIT FOR COLOR:

- 00 Black
 - 01 Clear
 - 02 Red
 - 03 Amber
 - 04 Green
 - 05 Blue
 - 06 Yellow
 - 07 Orange
 - 08 White
 - 09 Purple
 - 10 Fluor. Orange
 - 11 Fluor. Green
 - 12 Fluor. Blue
 - 13 Teal Green
 - 14 Gray
 - 15 Luminescent
 - 16 Gold
- Note: Not all colors available.

Nr.	STAND-UP TARGET PARTS	SPI PART Nr.
A	Modular Stand-Up Target Narrow Assy.	500-6138-XX
	Stand-Up Target Narrow (Insert)	545-6138-XX
B	Modular Stand-Up Target Square Assy.	500-6139-XX
	Stand-Up Target Square (Insert)	545-6139-XX
C	Modular Stand-Up Target Rectangle Assy.	500-6228-XX
	Stand-Up Target Rectangle (Insert)	545-6228-XX
D	Modular Stand-Up Target Round Assy.	500-6075-XX
	Stand-Up Target Round (Insert)	545-6075-XX
E	Mod. Stand-Up Target 1" Spherical Assy.	500-6189-XX
	Stand-Up Target 1" Spherical (Insert)	545-6189-XX

APPENDIX J



Coin Cards (USA & International Pricing Defaults) ► For Yellow Stock add -Y to the Part Number

If more than one Pricing Scheme is available for countries listed, the **F.** listed beside the option, denotes the Factory Default Setting.

FOR VIEWS OF THE LATEST or OPTIONAL USA, INTERNATIONAL / EURO AND CUSTOM COIN CARDS, VISIT OUR WEBSITE.

Not Shown USA 755-5400-10 Tournament Option \$2 = X1; 755-5400-11 Tournament Option \$1.50 = X1

USA 10 F. 755-5400-11 Front		USA 10 755-5400-11 Back		USA 2-7 or CANADA 755-5400-02 Front		FOR CUSTOM PRICING † 755-5400-01, -02 or -04 Back		USA 3 with ToPS™ 755-5400-03 or -09 Front		USA 5 with ToPS™ 755-5400-03 Back / -08 Front	
AUSTRALIA 1 F. 755-5406-00 Front		AUSTRALIA 2 755-5406-00 Back		CROATIA 755-5410-00 Front		FOR CUSTOM PRICING † 755-5410-00 Back		DENMARK 1 F. 755-5402-00 Front		DENMARK 2 755-5402-00 Back	
JAPAN 1 755-5408-01 Front		JAPAN 2 F. 755-5408-01 Back		MIDDLE EAST 755-5400-06 Front		ANY COUNTRY CAN USE 755-5400-06 Back		NEW ZEALAND 1 F. 755-5406-00 Back		NEW ZEALAND 2 755-5406-00 Front	
NORWAY 1 F. 755-5403-01 Front		NORWAY 2 755-5403-01 Back		RUSSIA F. 755-5411-00 Front		RUSSIA (ALTERNATE) 755-5411-00 Back		SOUTH AFRICA 755-5409-01 Front		FOR CUSTOM PRICING † 755-5409-01 Back	
SWEDEN 1 F. 755-5404-00 Front		SWEDEN 2 755-5404-00 Back		SWITZERLAND 1 F. 755-5405-00 Front		SWITZERLAND 2 755-5405-00 Back		TAIWAN 755-5412-00 Front		FOR CUSTOM PRICING † 755-5412-00 Back	
UK 1 755-5407-00 Front		UK 3 755-5407-00 Back		UK 5 F. 755-5407-01 Front		FOR CUSTOM PRICING † 755-5407-01 Back		Appendix J Notes: 1. Coin Card on Game is determined by original shipping country destination. 2. Optional Coin Card(s), are available via your distributor or via free download @ www.sternpinball.com/coinagecards.shtml . Older style Coin Cards (foreign or domestic) not available on our website or no longer available through your distributor, are obsolete. 3. Coin Cards which have a Blank Backside can be used for †Custom Pricing.			

Not Shown EURO 755-5401-20 Tournament Custom (can fill in your own pricing).

EURO 1 755-5401-01 1-Side Only		EURO 2 755-5401-02 1-Side Only		EURO 3 755-5401-03 1-Side Only		EURO 4 755-5401-04 1-Side Only		EURO 5 755-5401-05 1-Side Only		EURO 6 755-5401-06 1-Side Only	
EURO 7 755-5401-07 1-Side Only		EURO 8 755-5401-08 1-Side Only		EURO 9 755-5401-09 1-Side Only		EURO 10 755-5401-10 1-Side Only		EURO 11 755-5401-11 1-Side Only		EURO 12 755-5401-12 1-Side Only	

► EURO FACTORY DEFAULT SUMMARY TABLE ◄

EURO 1	EURO 2	EURO 3	EURO 4	EURO 5	EURO 6	EURO 7	EURO 8	EURO 9	EURO 10	EURO 11	EURO 12
BELGIUM ITALY 1 PORTUGAL	GERMANY 2	NETHERLANDS SPAIN			GREECE		FINLAND	AUSTRIA	FRANCE		

Section 3, Chapter 4, GO TO ADJUSTMENTS MENU, Adj. 18, Game Pricing, USA & International (non-Euro) and Euro 1-12 Summary & International (Euro) Standard Pricing Select Tables, summarizes Standard or Custom Pricing Schemes & the Dip Switch Setting required.

Download all Coin Cards from our website:
<http://www.sternpinball.com/coinagecards.shtml>

Appendix J:

1
 or order SPI Part No.: 970-2002-00, 970-2003-00 or 970-2004-00 CD-Rom through your Local Distributor.

Coin Cards (USA & Intn'l Pricing Defaults)