

Table of Contents

Sheet 1B	Space Duel™ Upright Wiring Diagram (037937-01 A)
Sheet 2A	Space Duel Cocktail Wiring Diagram (038027-01 1)
Sheet 2B	Color X-Y Power Supply Wiring Diagram (037394-01 B) Regulator/Audio II Schematic Diagram (035435-04 A)
Sheet 3A	Fluorescent Light and Speaker Wiring Diagram (035833-01 A) Coin Door Wiring Diagram (037542-01 A) Utility Panel Wiring Diagram (038004-01 A)
Sheet 3B	Guide to Game PCB Schematic Signal Distribution (036837-01, or -02 A) Sheets 4A-8A
Sheet 4A	Power Input Clock, Power-on Reset, Watchdog
Sheet 4B	Test Connector, Microprocessor, Address Decoder
Sheet 5A	Read-Only Memory, Random-Access Memory, High Score Table
Sheet 5B	Coin Door and Control Panel Input, Option Switch Input and Audio Output, Coin Door and Control Panel Output
Sheet 6A	Vector Address Decoder, Vector Read-Only Memory, Vector Random-Access Memory, Vector Memory Data Buffer
Sheet 6B	Vector Data Shifters, OP Code and Intensity Latches
Sheet 7A	State Machine, State Machine Clock, State Machine Clock Logic, Decoder Disable, Address Controller
Sheet 7B	Normalization Flag, Vector Scaling, Center Flag, Go Flag, Vector Flag, Vector Timer
Sheet 8A	Z Blanking, R-G-B Output
Sheet 8B	DAC Reference and Bipolar Voltage Sources, X-Axis Output, Y-Axis Output
Sheet 9A	Color X-Y Display Schematic Diagram (92-053 2)
Sheet 9B	<i>Troubleshooting with the CAT Box:</i> Memory Map, Troubleshooting with Read/Write Controller A. CAT Box Preliminary Set-Up B. Address Lines C. RAM D. Option Switch Inputs E. Custom Audio I/O Chips
Sheet 10A	F. Player and Option Switch P10/11 Inputs G. Analog Vector-Generator H. LED, Coin Counter, and Invert Outputs
Sheet 10B	Troubleshooting with Signature Analysis A. Signature Analysis Set-Up B. Address Lines C. Address Decoder D. ROM and Data Lines Watchdog

NOTE
This staple temporarily holds the
schematic package together. Re-
move the staple before using the
schematics.

Schematic Package Supplement to

SPACE DUEL™

Operation, Maintenance and Service Manual



© ATARI INC. 1982

Space Duel™ Upright, Wiring Diagram

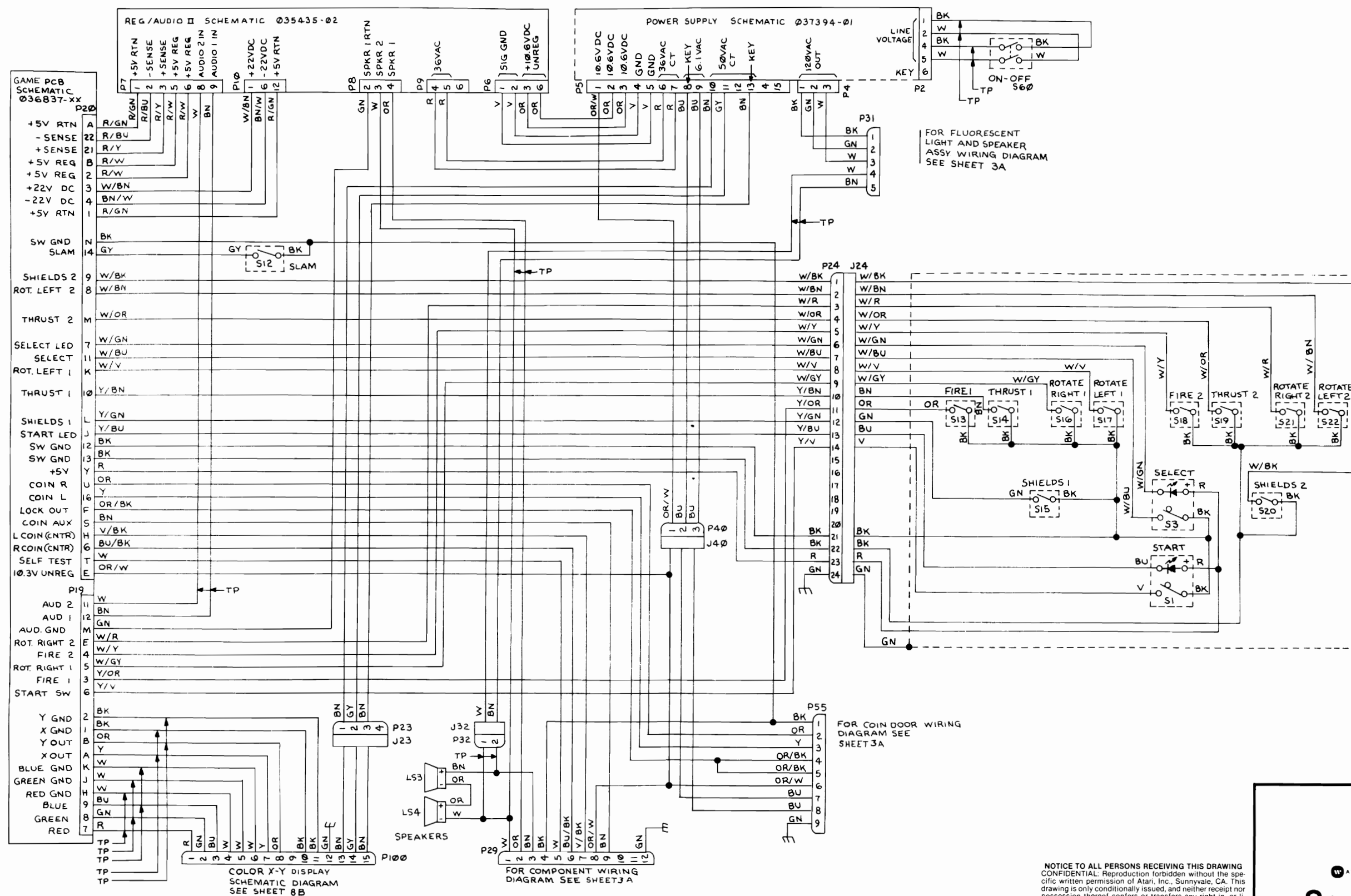

NOTICE TO ALL PERSONS RECEIVING THIS DRAWING
 CONFIDENTIAL: Reproduction forbidden without the specific written permission of Atari, Inc., Sunnyvale, CA. This drawing is only conditionally issued, and neither receipt nor possession thereof confers or transfers any right in, or license to use, the subject matter of the drawing or any design or technical information shown thereon, nor any right to reproduce this drawing or any part thereof. Except for manufacture by vendors of Atari, Inc., and for manufacture under the corporation's written license, no right is granted to reproduce this drawing or the subject matter thereof, unless by written agreement with or written permission from the corporation.

ATARI
 A Warner Communications Company

Space Duel™

© ATARI INC. 1982

Sheet 1B
 SP-181 1st printing

Space Duel™ Cocktail, Wiring Diagram

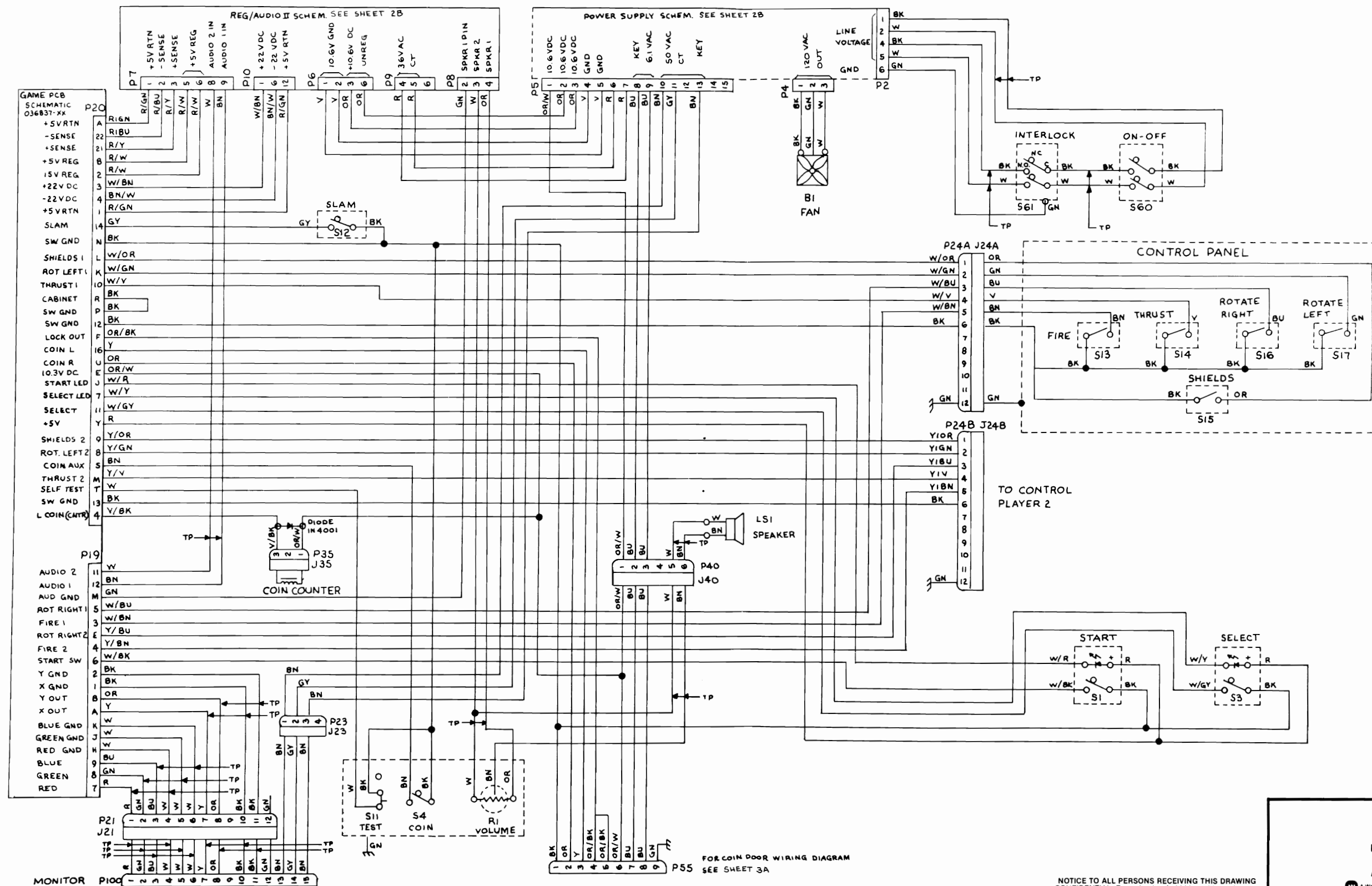

NOTICE TO ALL PERSONS RECEIVING THIS DRAWING
 CONFIDENTIAL: Reproduction forbidden without the specific written permission of Atari, Inc., Sunnyvale, CA. This drawing is only conditionally issued, and neither receipt nor possession thereof confers or transfers any right in, or license to use, the subject matter of the drawing or any design or technical information shown thereon, nor any right to reproduce this drawing or any part thereof. Except for manufacture by vendors of Atari, Inc., and for manufacture under the corporation's written license, no right is granted to reproduce this drawing or the subject matter thereof, unless by written agreement with or written permission from the corporation.

ATARI
 A Warner Communications Company

Space Duel™

© ATARI INC. 1982

Sheet 2A
 SP-181 1st printing

Regulator/Audio II PCB Schematic Diagram

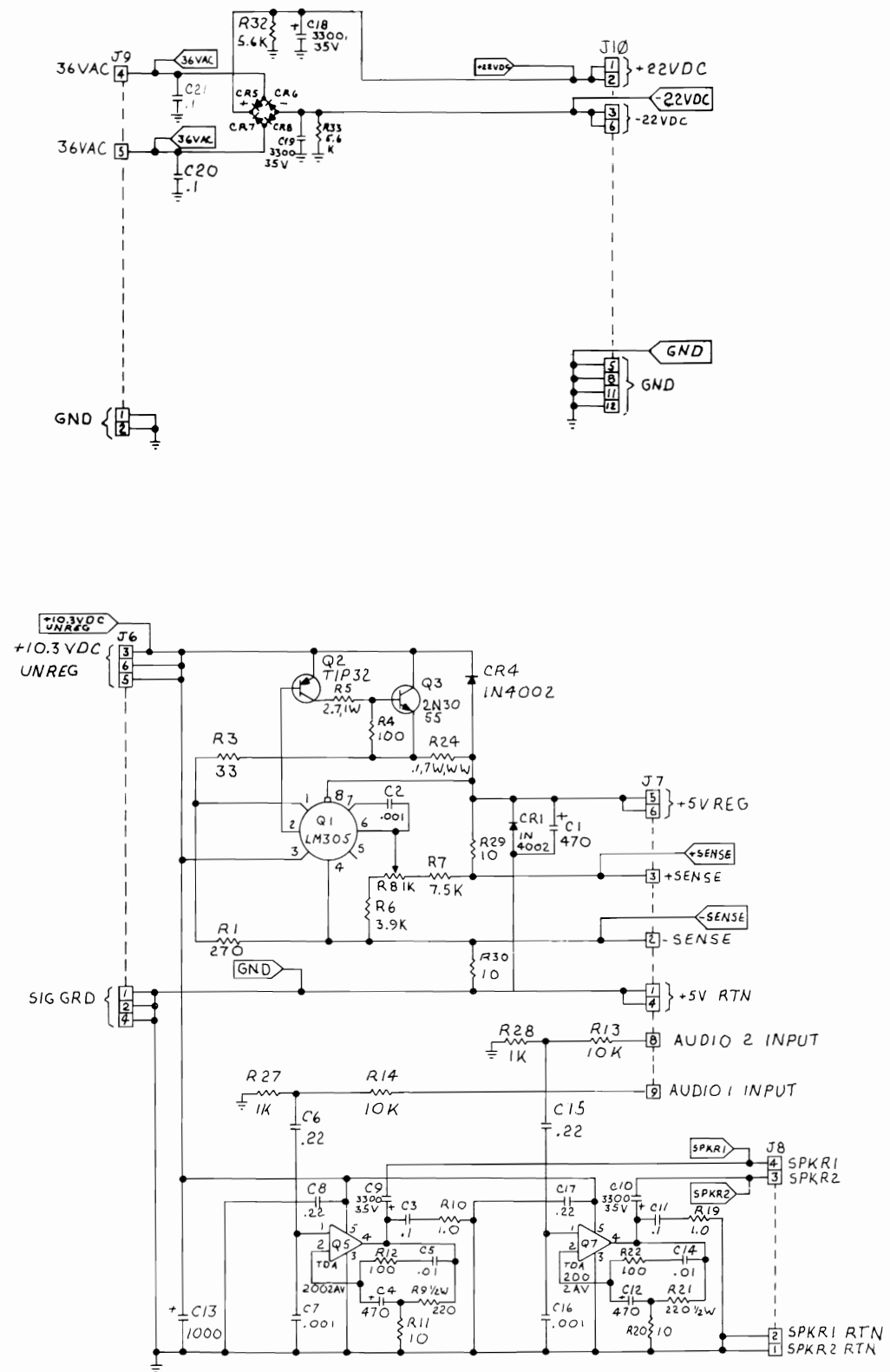

Color X-Y Power Supply Wiring Diagram

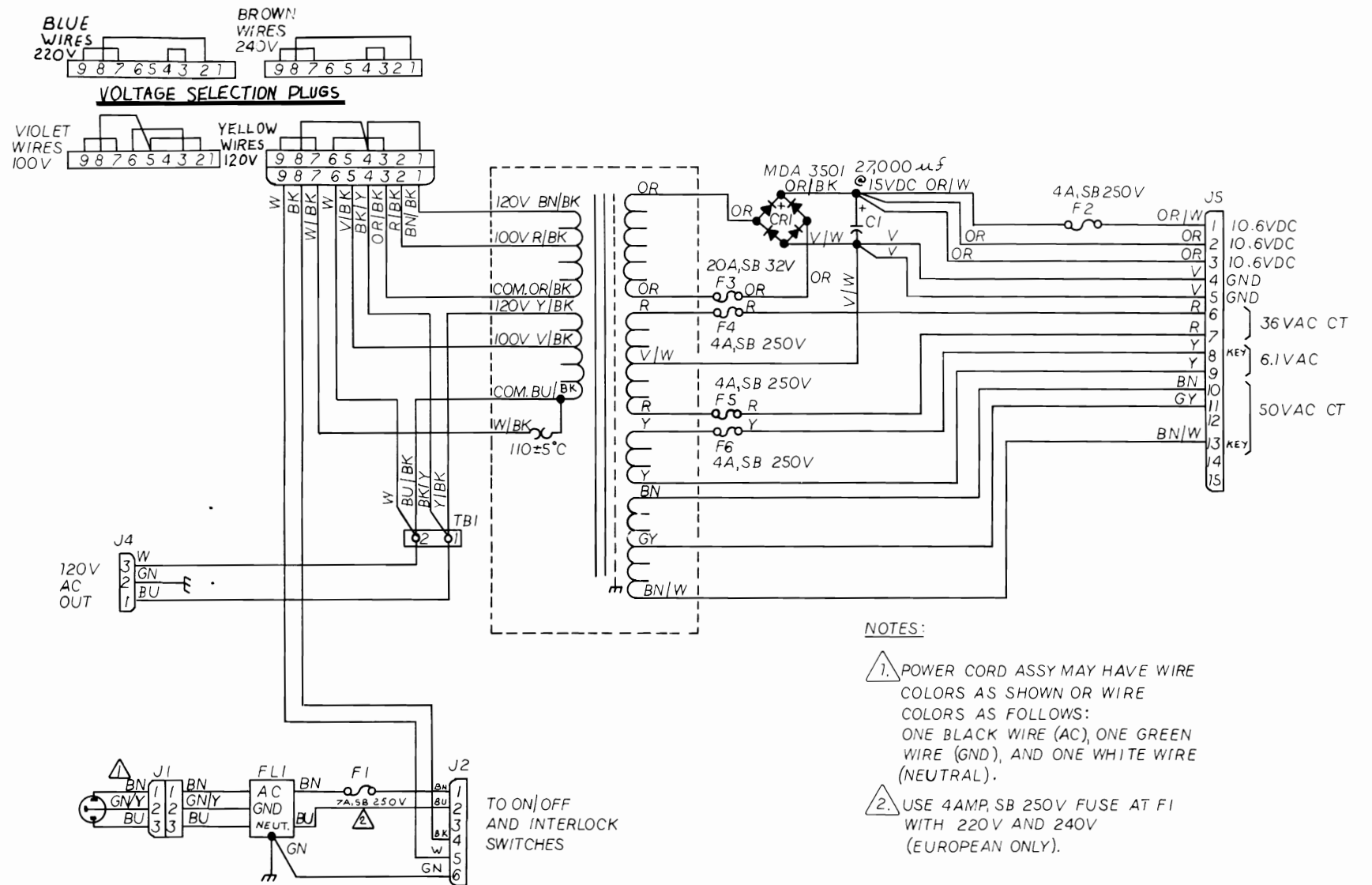

NOTICE TO ALL PERSONS RECEIVING THIS DRAWING
 CONFIDENTIAL. Reproduction forbidden without the specific written permission of Atari, Inc., Sunnyvale, CA. This drawing is only conditionally issued, and neither receipt nor possession thereof confers or transfers any right in, or license to use, the subject matter of the drawing or any design or technical information shown thereon, nor any right to reproduce this drawing or any part thereof. Except for manufacture by vendors of Atari, Inc., and for manufacture under the corporation's written license, no right is granted to reproduce this drawing or the subject matter thereof, unless by written agreement with or written permission from the corporation.



Space Duel™

Coin Door Wiring Diagram

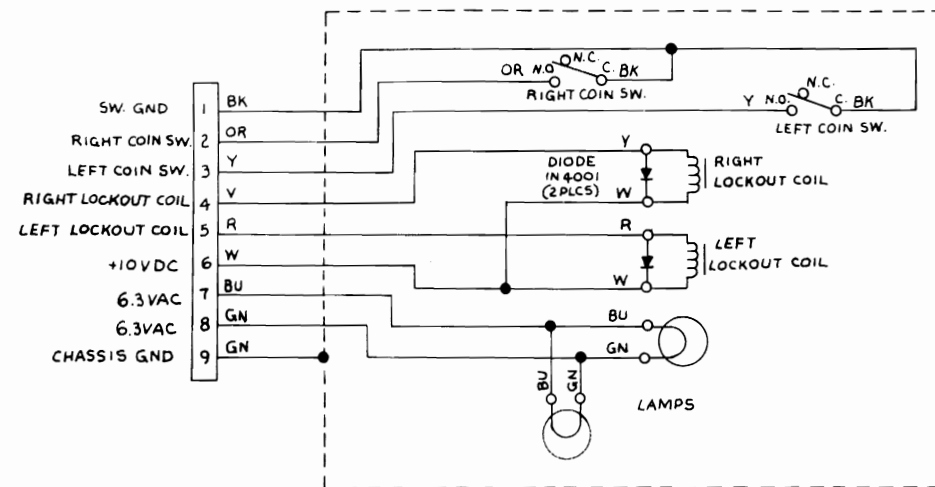

Utility Panel Wiring Diagram

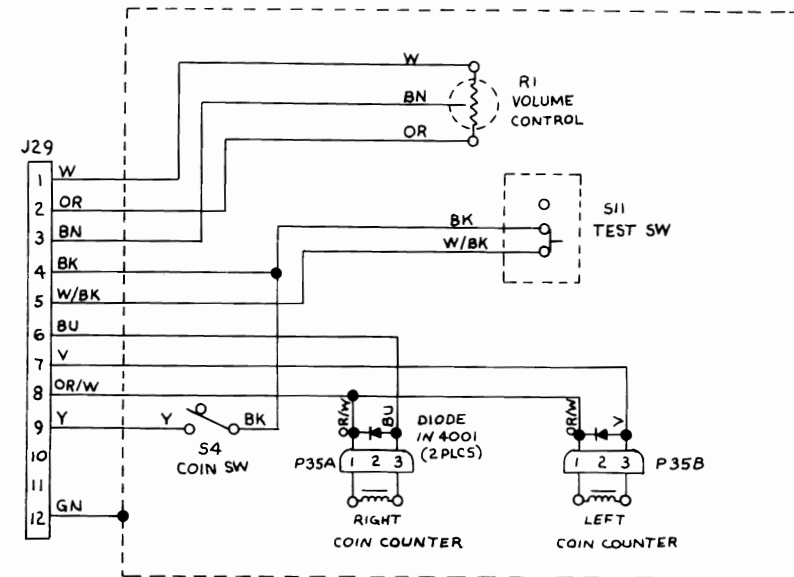

Fluorescent Light And Speaker Wiring Diagram

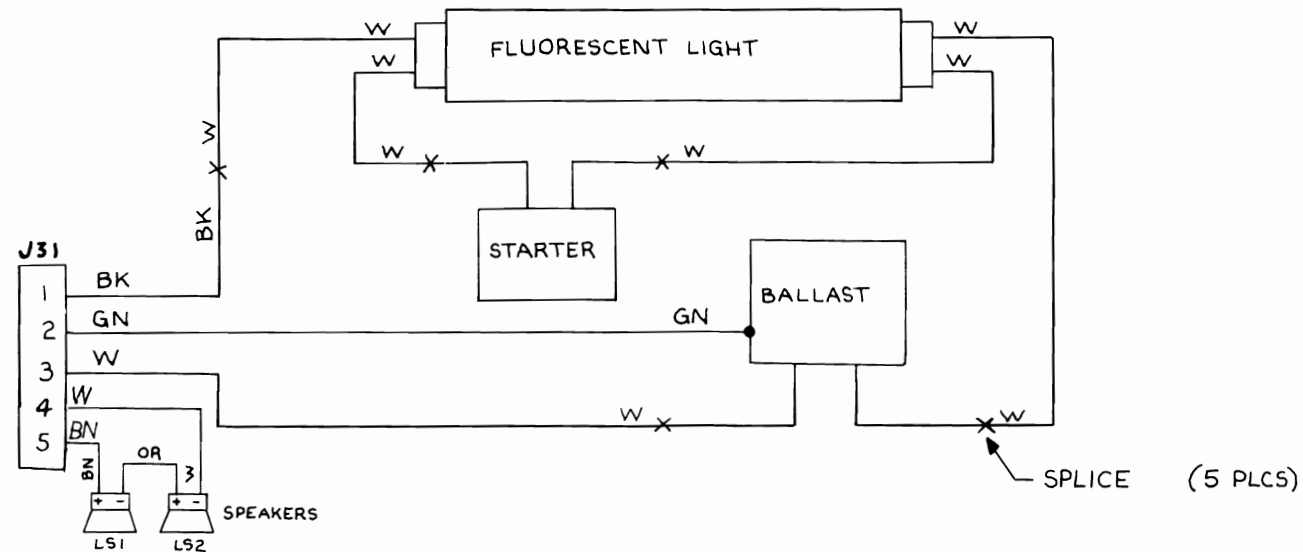

NOTICE TO ALL PERSONS RECEIVING THIS DRAWING
 CONFIDENTIAL: Reproduction forbidden without the specific written permission of Atari, Inc., Sunnyvale, CA. This drawing is only conditionally issued, and neither receipt nor possession thereof confers or transfers any right in, or license to use, the subject matter of the drawing or any design or technical information shown thereon, nor any right to reproduce this drawing or any part thereof. Except for manufacture by vendors of Atari, Inc., and for manufacture under the corporation's written license, no right is granted to reproduce this drawing or the subject matter thereof, unless by written agreement with or written permission from the corporation.



ATARI
 A Warner Communications Company
Space Duel™

Guide to Game PCB Schematics

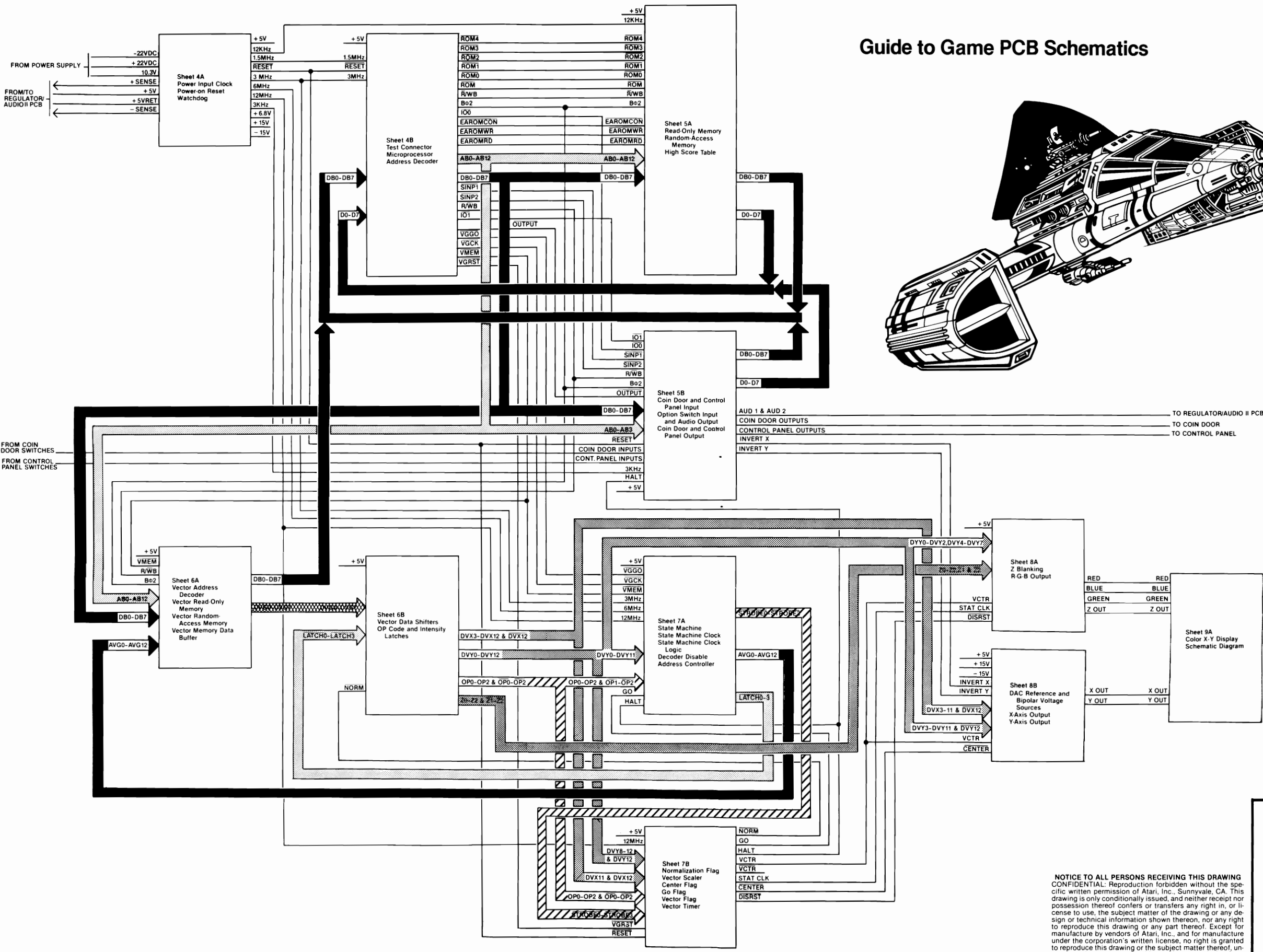
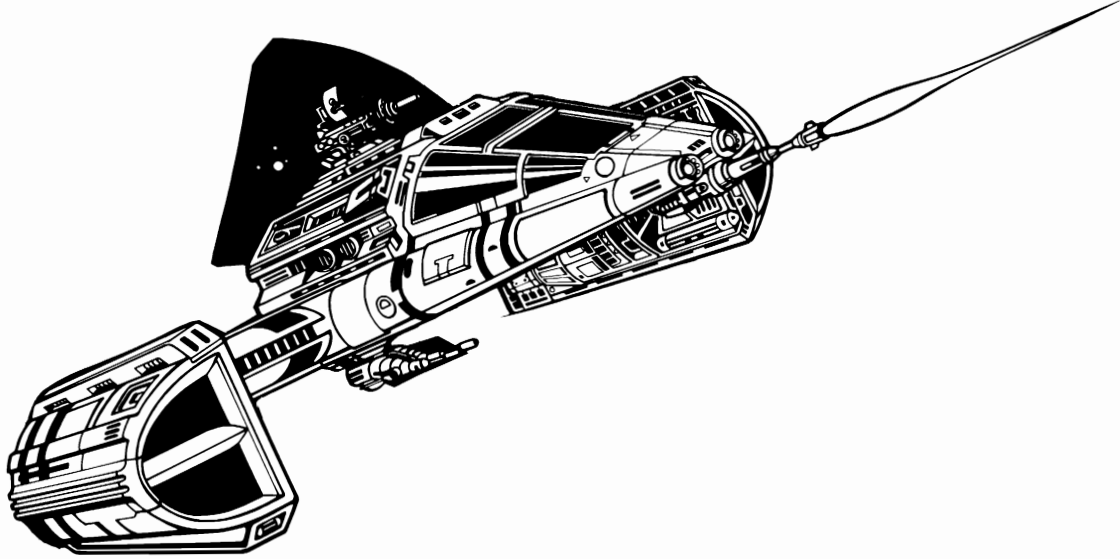

NOTICE TO ALL PERSONS RECEIVING THIS DRAWING
 CONFIDENTIAL: Reproduction forbidden without the specific written permission of Atari, Inc., Sunnyvale, CA. This drawing is only conditionally issued, and neither receipt nor possession thereof confers or transfers any right in, or license to use, the subject matter of the drawing or any design or technical information shown thereon, nor any right to reproduce this drawing or any part thereof. Except for manufacture by vendors of Atari, Inc., and for manufacture under the corporation's written license, no right is granted to reproduce this drawing or the subject matter thereof, unless by written agreement with or written permission from the corporation.

ATARI
 A Warner Communications Company

Space Duel™

© ATARI INC. 1982

Sheet 3B
 SP-181 1st printing

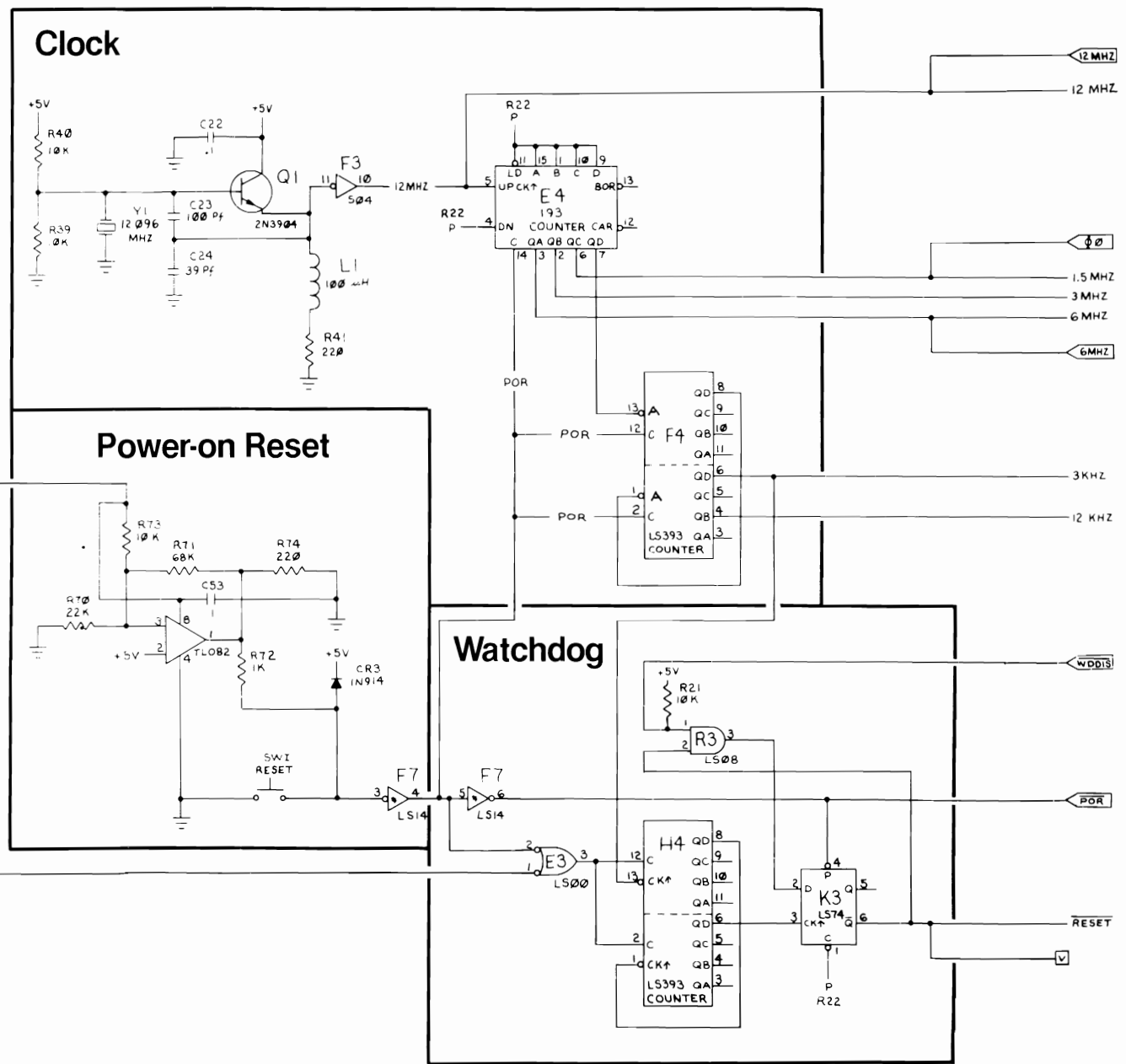
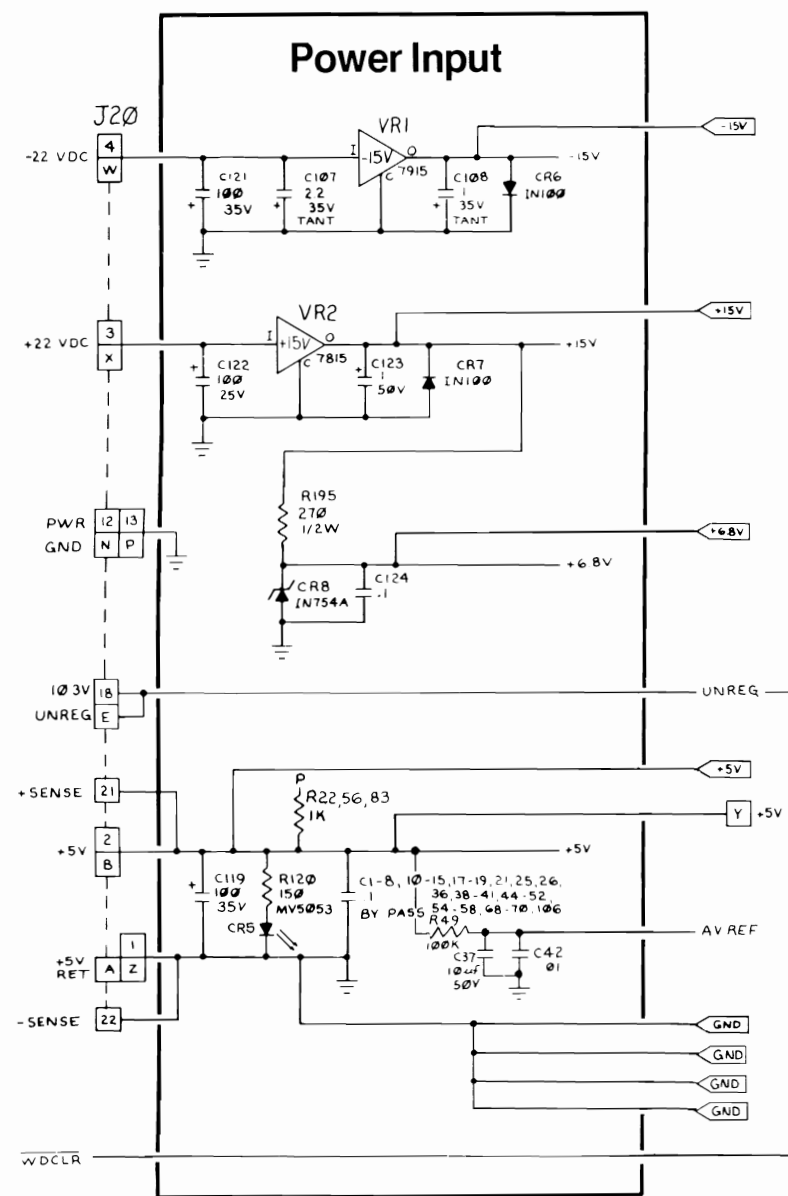

NOTICE TO ALL PERSONS RECEIVING THIS DRAWING
 CONFIDENTIAL: Reproduction forbidden without the specific written permission of Atari, Inc., Sunnyvale, CA. This drawing is only conditionally issued, and neither receipt nor possession thereof confers or transfers any right in, or license to use, the subject matter of the drawing or any design or technical information shown thereon, nor any right to reproduce this drawing or any part thereof. Except for manufacture by vendors of Atari, Inc., and for manufacture under the corporation's written license, no right is granted to reproduce this drawing or the subject matter thereof, unless by written agreement with or written permission from the corporation.



Space Duel™

Test Connector

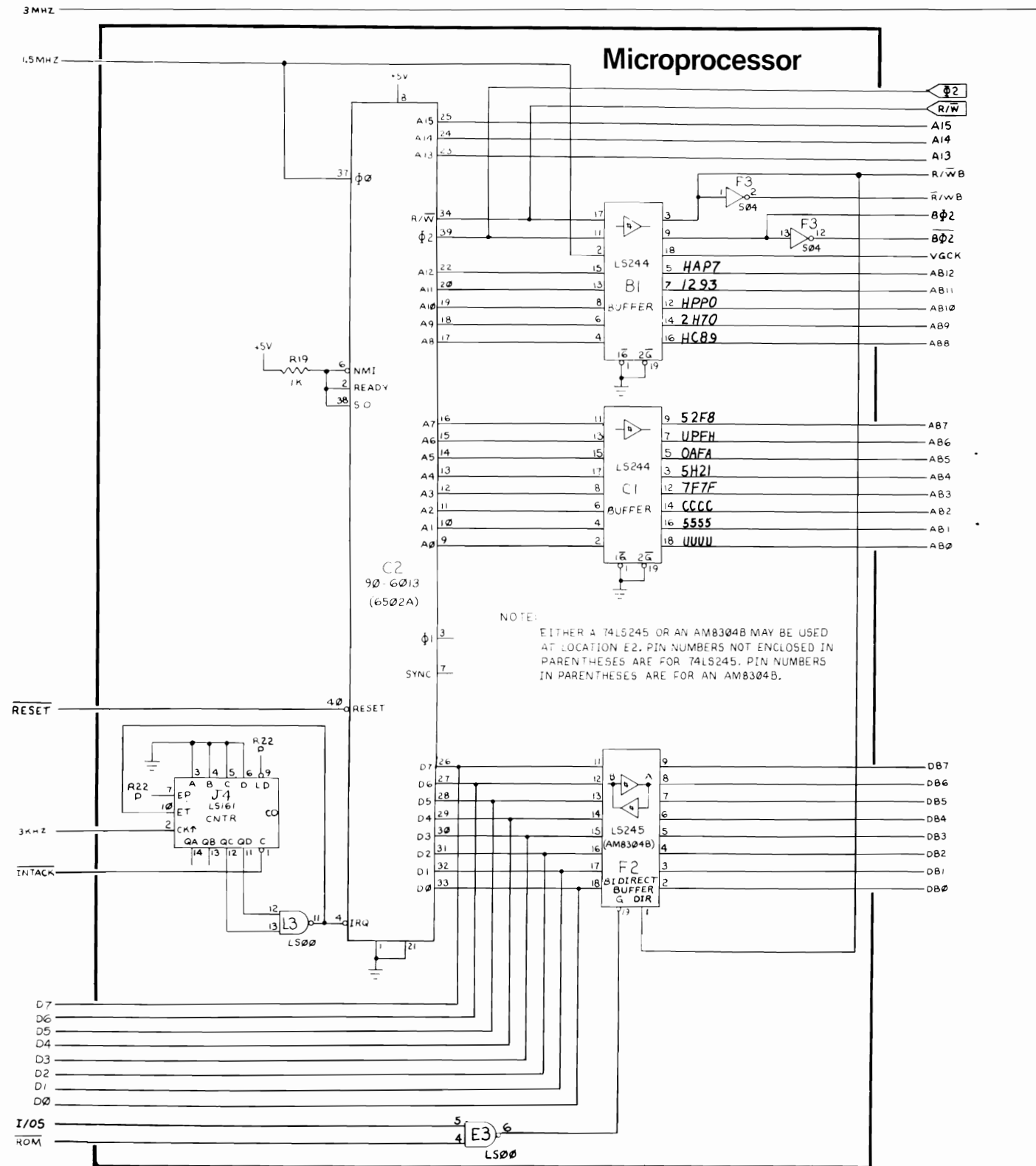
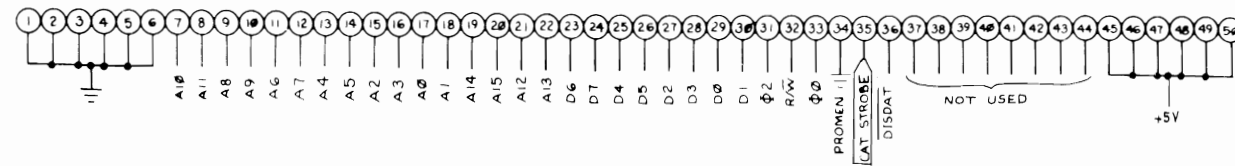

Address Decoder

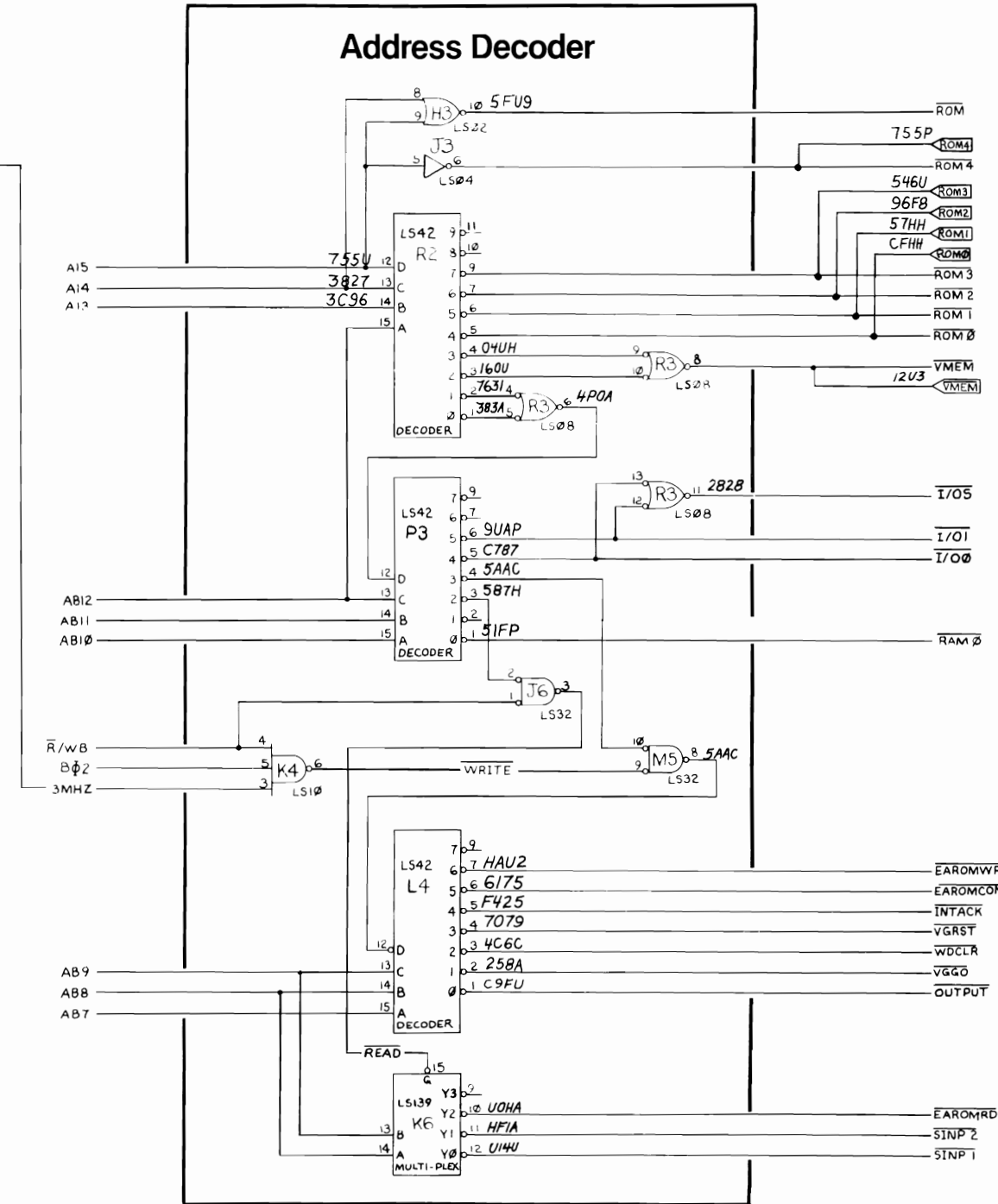

NOTICE TO ALL PERSONS RECEIVING THIS DRAWING
CONFIDENTIAL: Reproduction forbidden without the specific written permission of Atari, Inc., Sunnyvale, CA. This drawing is only conditionally issued, and neither receipt nor possession thereof confers or transfers any right in, or license to use, the subject matter of the drawing or any design or technical information shown thereon, nor any right to reproduce this drawing or any part thereof. Except for manufacture by vendors of Atari, Inc., and for manufacture under the corporation's written license, no right is granted to reproduce this drawing or the subject matter thereof, unless by written agreement with or written permission from the corporation.



A Warner Communications Company

Space Duel™

© ATARI INC. 1982

Sheet 4B
SP-181 1st printing

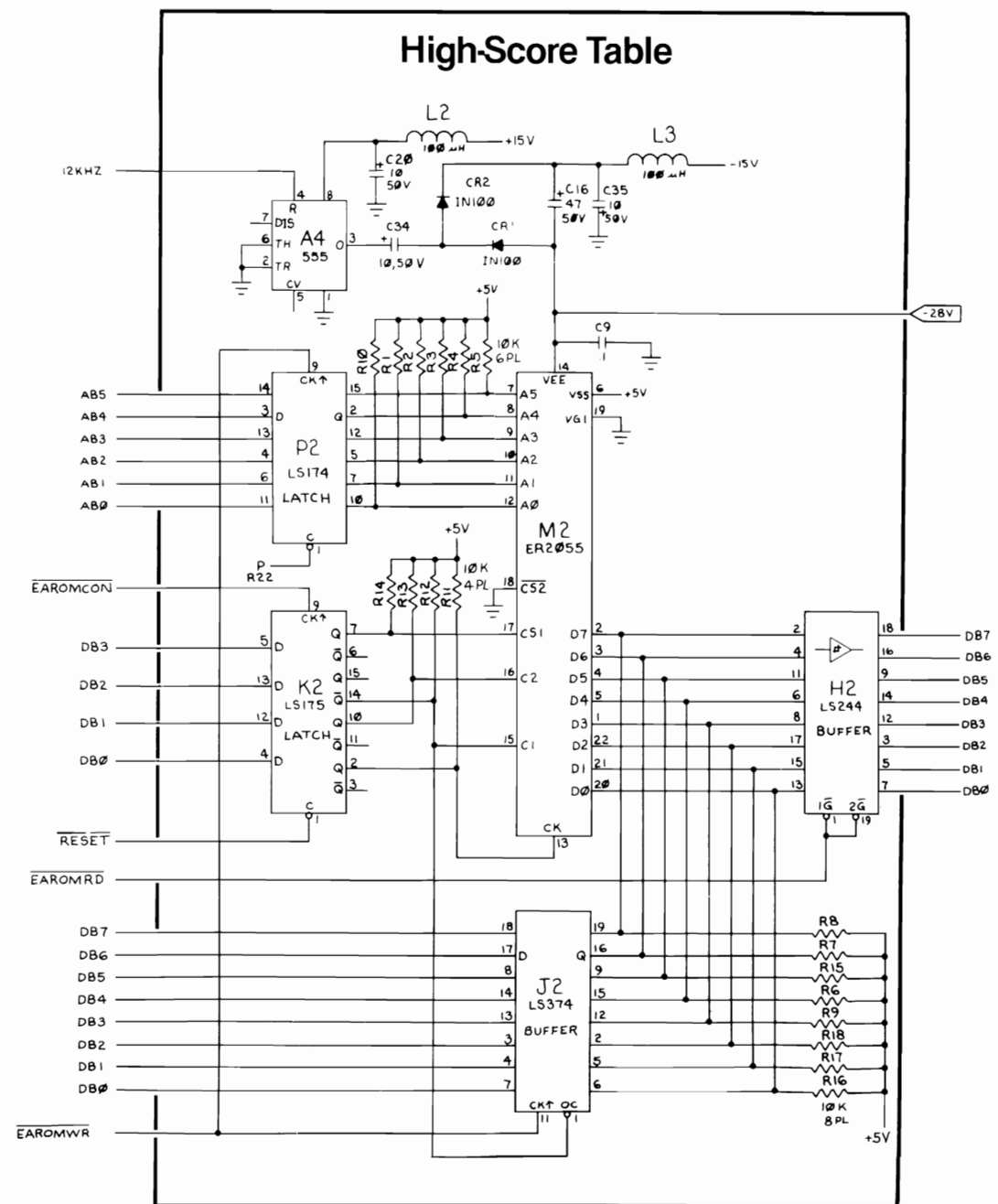
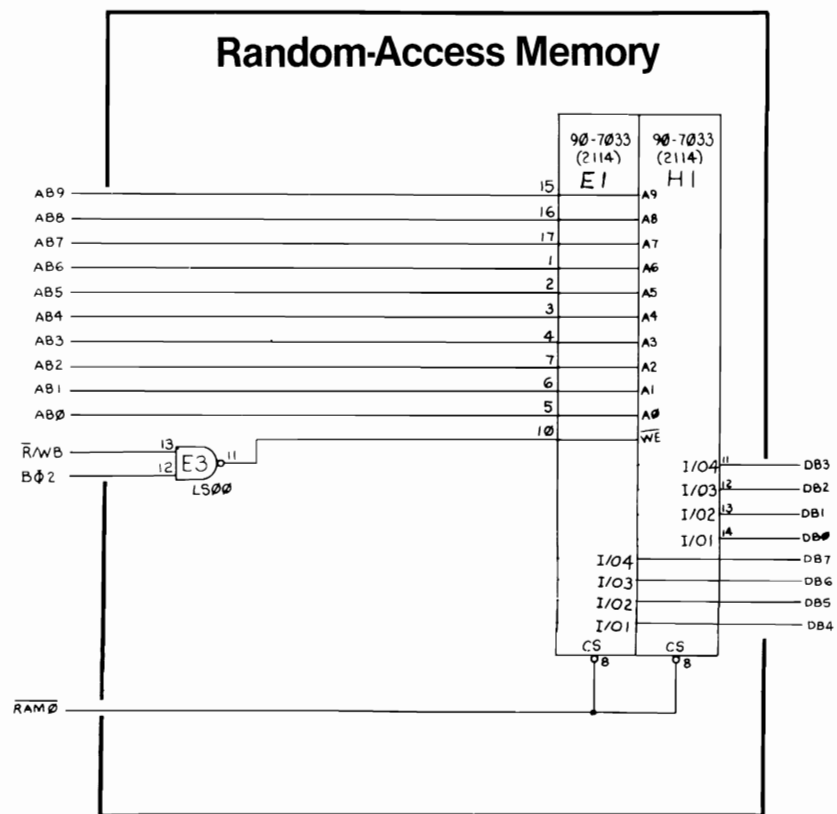
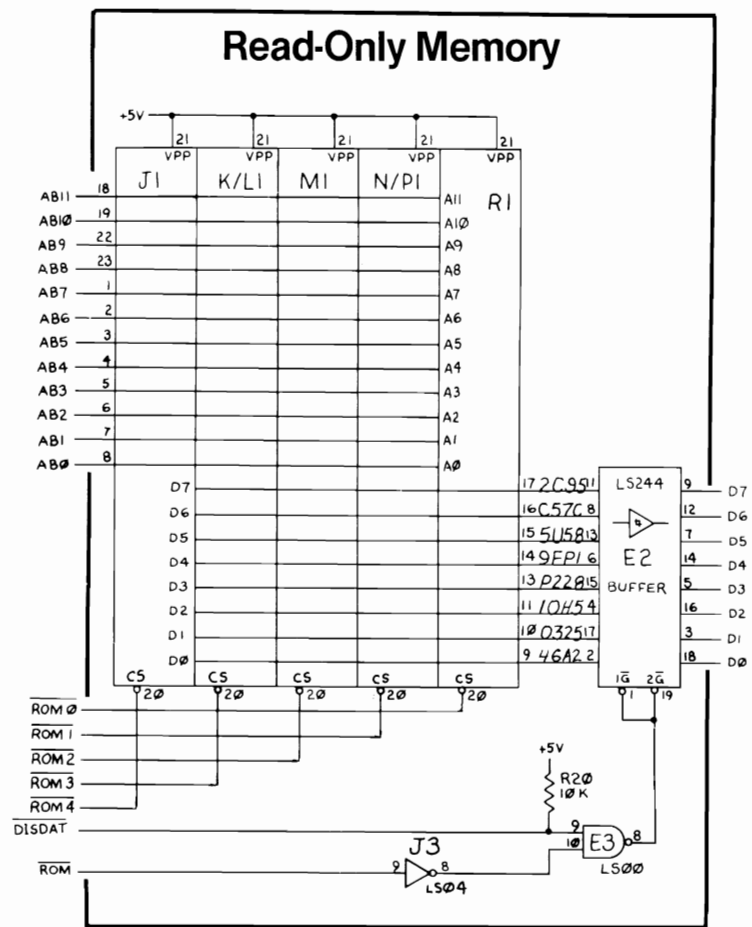

NOTICE TO ALL PERSONS RECEIVING THIS DRAWING
 CONFIDENTIAL: Reproduction forbidden without the specific written permission of Atari, Inc., Sunnyvale, CA. This drawing is only conditionally issued, and neither receipt nor possession thereof confers or transfers any right in, or license to use, the subject matter of the drawing or any design or technical information shown thereon, nor any right to reproduce this drawing or any part thereof. Except for manufacture by vendors of Atari, Inc., and for manufacture under the corporation's written license, no right is granted to reproduce this drawing or the subject matter thereof, unless by written agreement with or written permission from the corporation.



ATARI
 A Warner Communications Company
Space Duel™

Coin Door And Control Panel Input

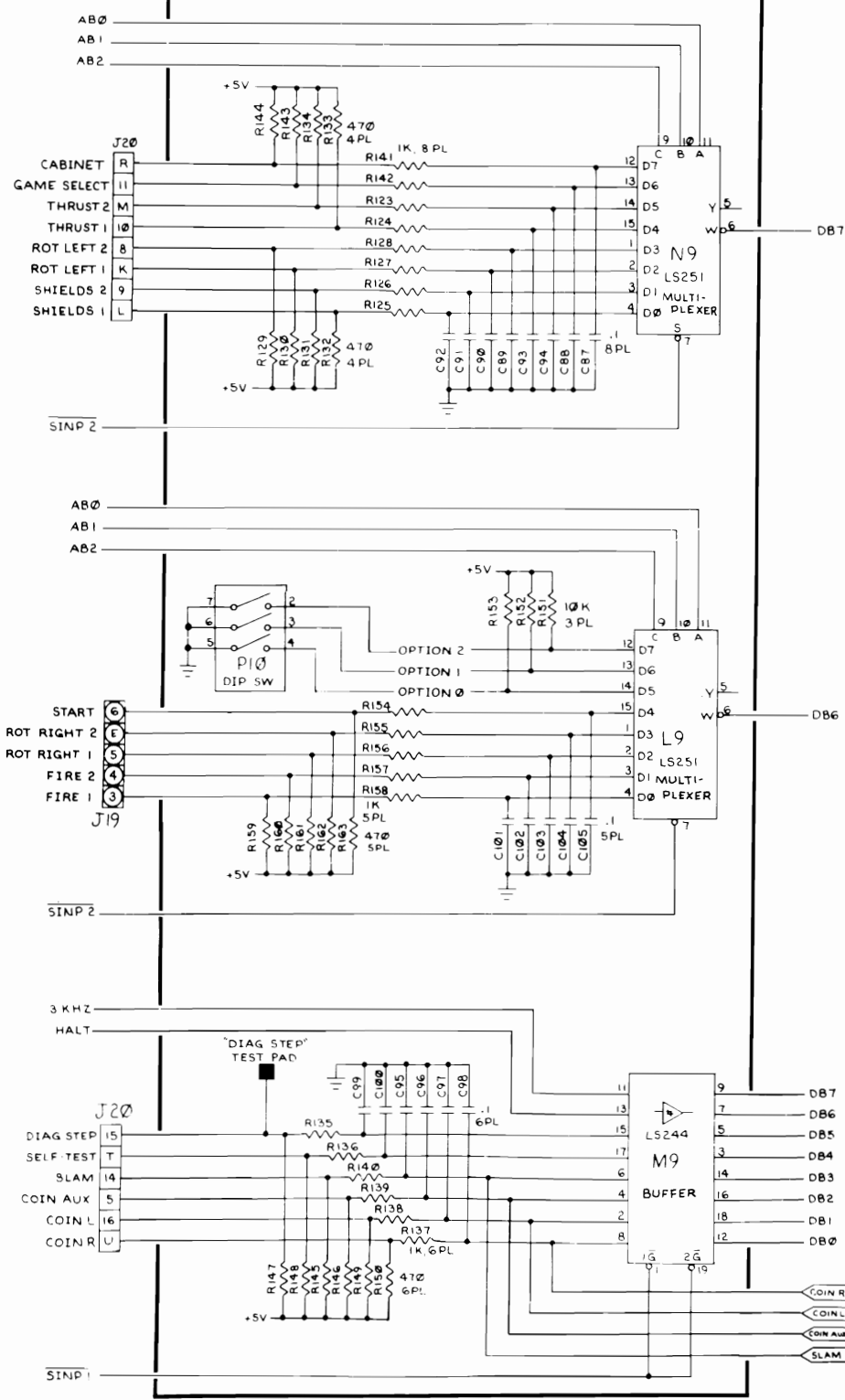

Option Switch Input And Audio Output

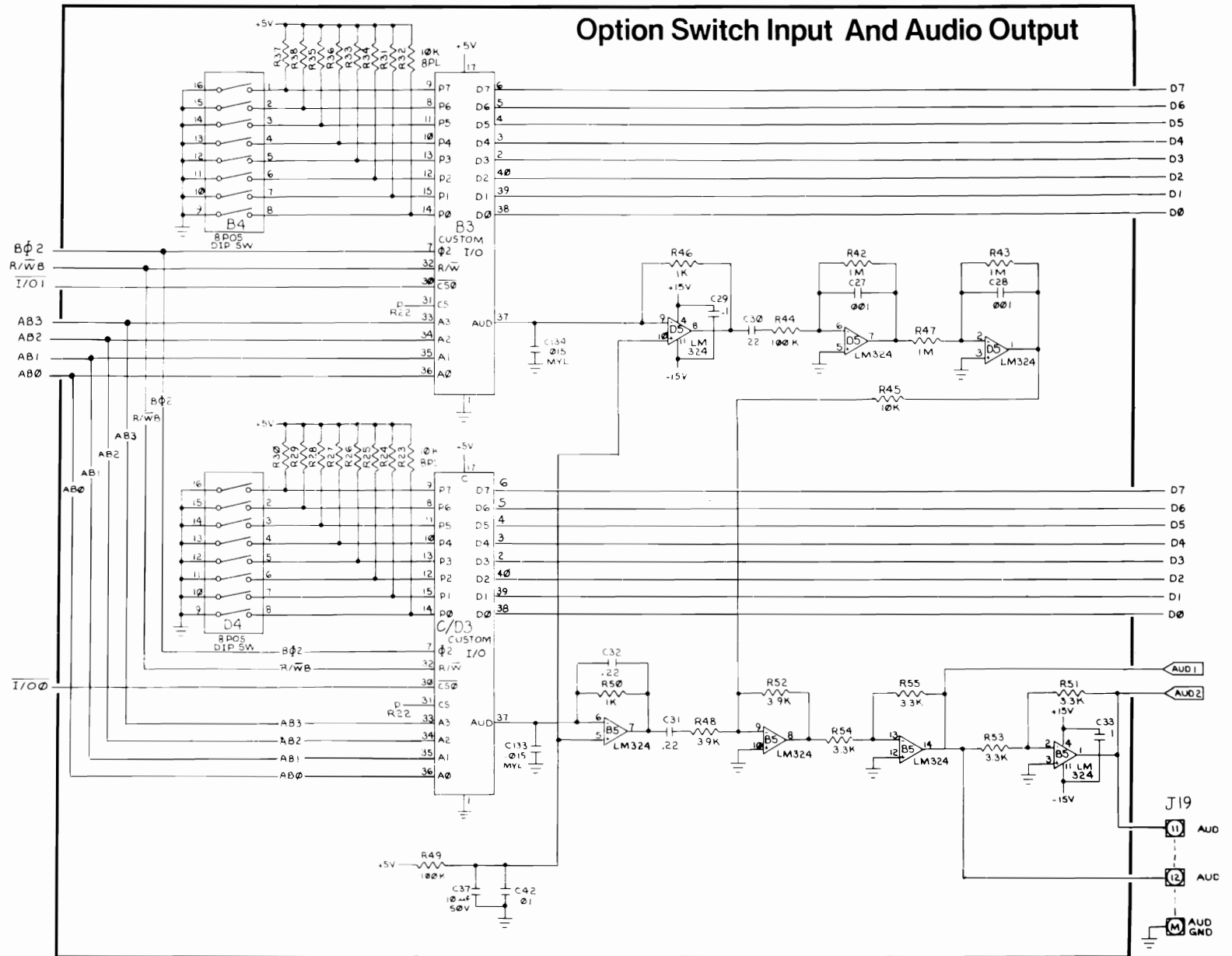

Coin Door And Control Panel Output

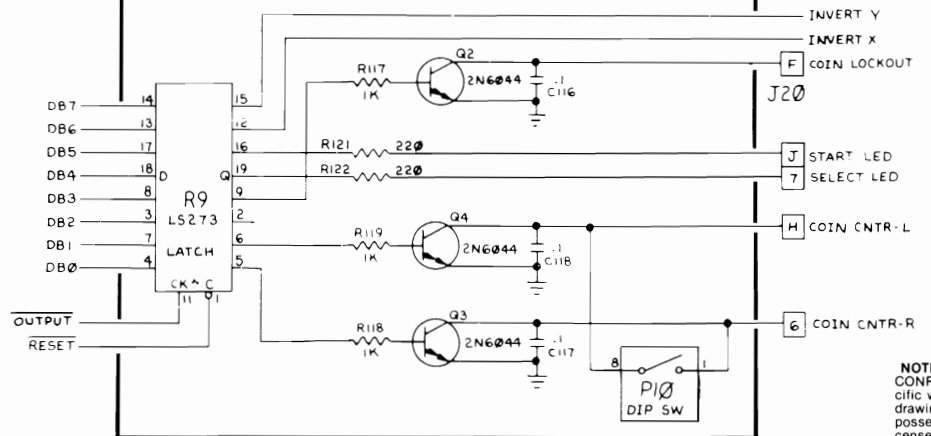

NOTICE TO ALL PERSONS RECEIVING THIS DRAWING
 CONFIDENTIAL: Reproduction forbidden without the specific written permission of Atari, Inc., Sunnyvale, CA. This drawing is only conditionally issued, and neither receipt nor possession thereof confers or transfers any right in, or license to use, the subject matter of the drawing or any design or technical information shown thereon, nor any right to reproduce this drawing or any part thereof. Except for manufacture by vendors of Atari, Inc., and for manufacture under the corporation's written license, no right is granted to reproduce this drawing or the subject matter thereof, unless by written agreement with or written permission from the corporation.



Space Duel™

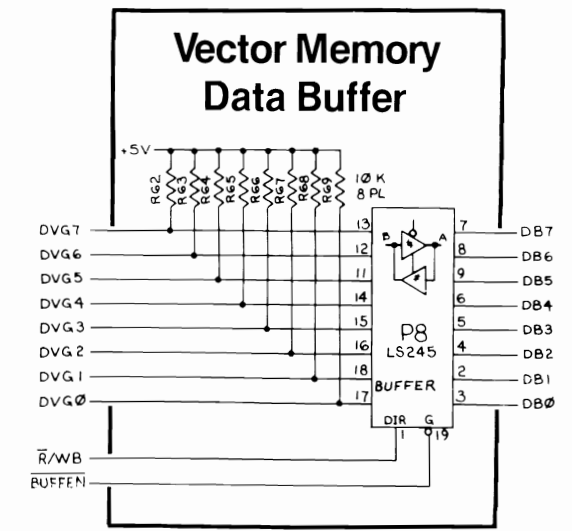
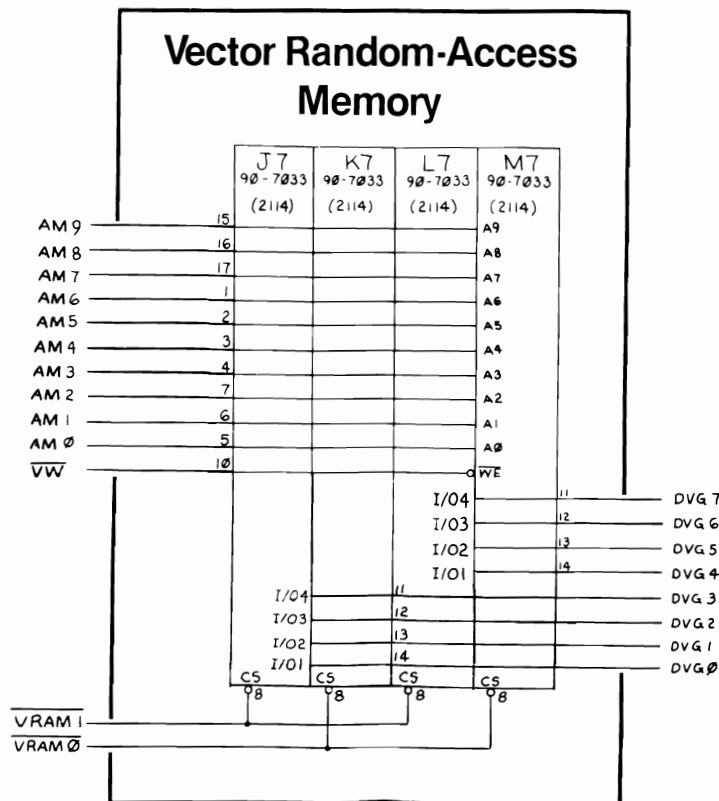
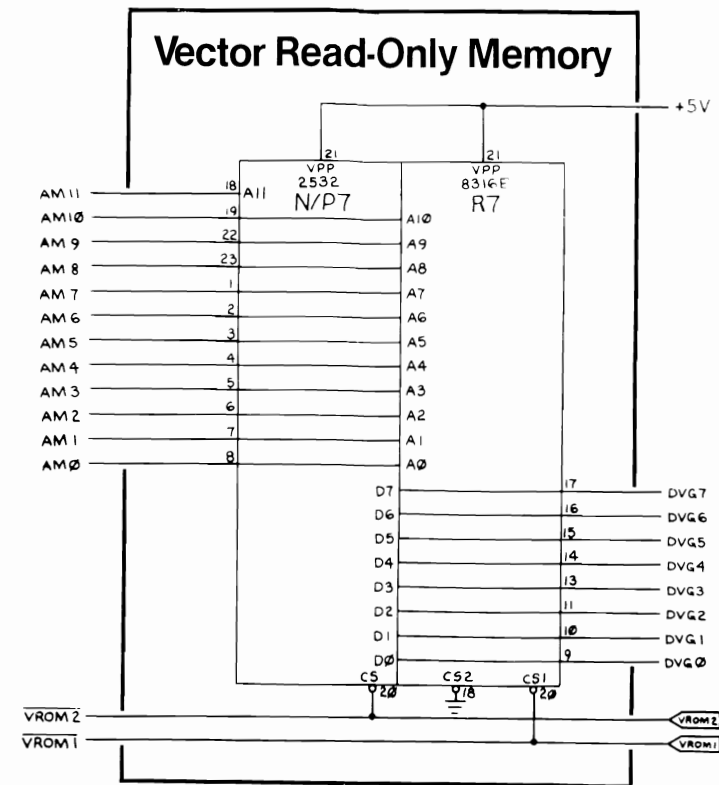
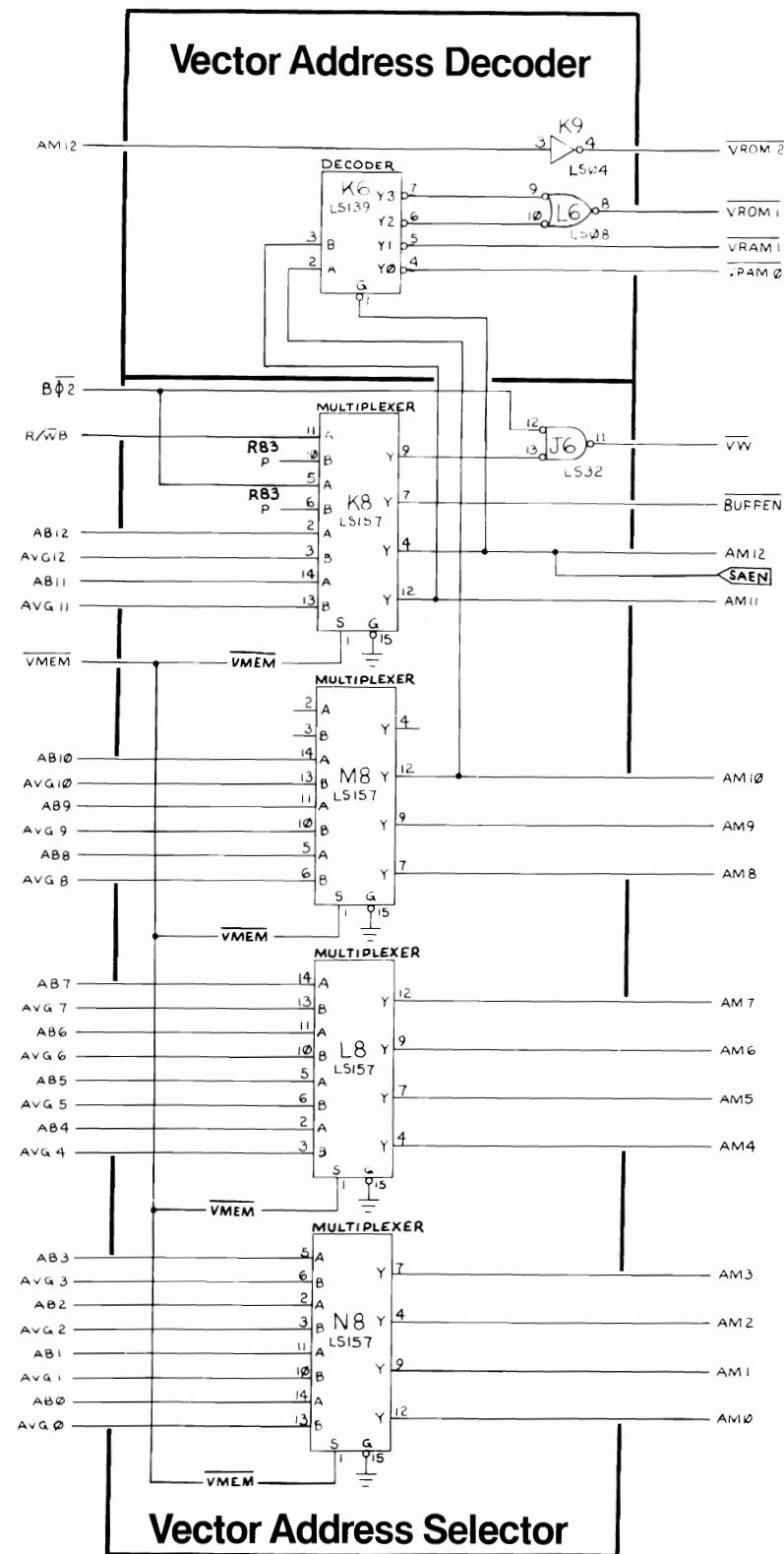

NOTICE TO ALL PERSONS RECEIVING THIS DRAWING
 CONFIDENTIAL: Reproduction forbidden without the specific written permission of Atari, Inc., Sunnyvale, CA. This drawing is only conditionally issued, and neither receipt nor possession thereof confers or transfers any right in, or license to use, the subject matter of the drawing or any design or technical information shown thereon, nor any right to reproduce this drawing or any part thereof. Except for manufacture by vendors of Atari, Inc., and for manufacture under the corporation's written license, no right is granted to reproduce this drawing or the subject matter thereof, unless by written agreement with or written permission from the corporation.

ATARI
 A Warner Communications Company

Space Duel™

Sheet 6A
 SP-181 1st printing

© ATARI INC. 1982

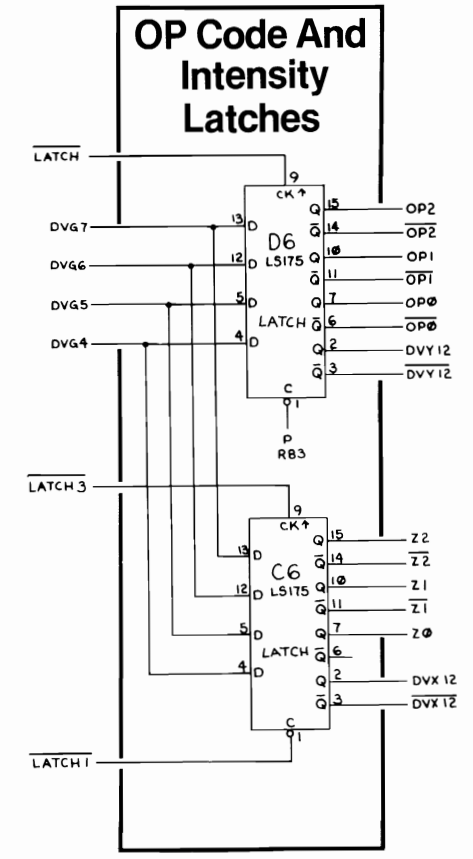
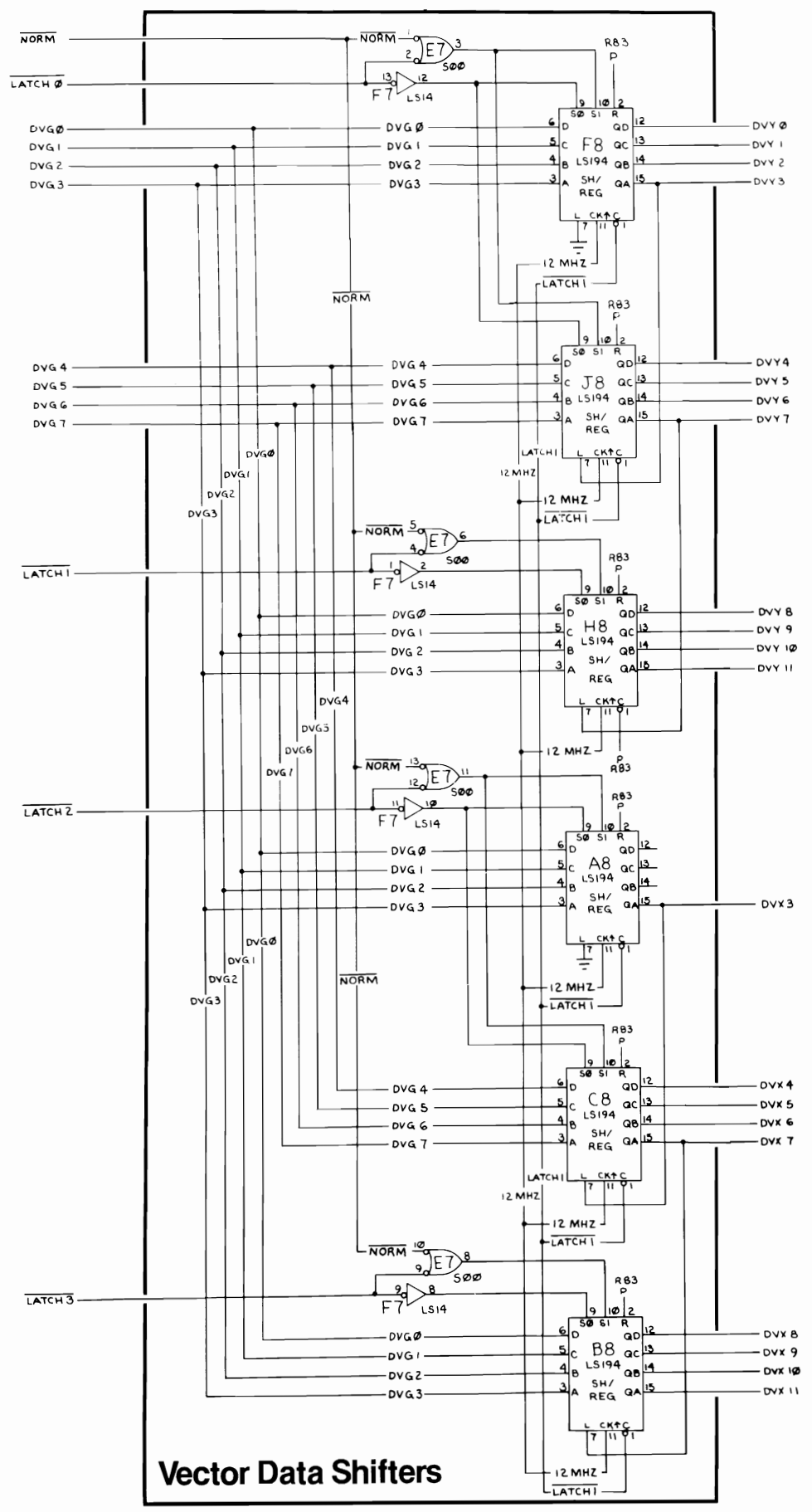

NOTICE TO ALL PERSONS RECEIVING THIS DRAWING
 CONFIDENTIAL: Reproduction forbidden without the specific written permission of Atari, Inc., Sunnyvale, CA. This drawing is only conditionally issued, and neither receipt nor possession thereof confers or transfers any right in, or license to use, the subject matter of the drawing or any design or technical information shown thereon, nor any right to reproduce this drawing or any part thereof. Except for manufacture by vendors of Atari, Inc., and for manufacture under the corporation's written license, no right is granted to reproduce this drawing or the subject matter thereof, unless by written agreement with or written permission from the corporation.



Space Duel™

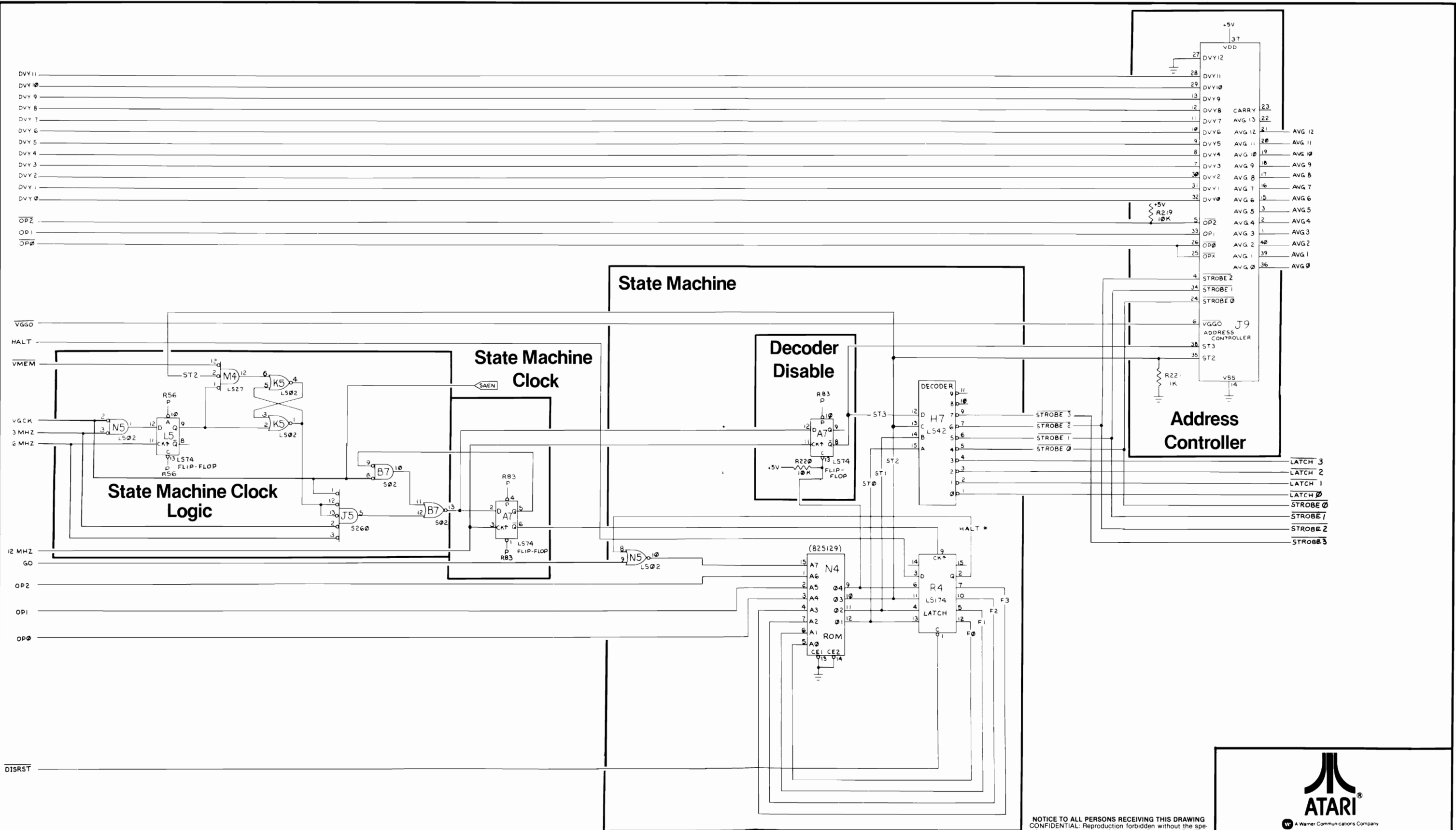

NOTICE TO ALL PERSONS RECEIVING THIS DRAWING
 CONFIDENTIAL: Reproduction forbidden without the specific written permission of Atari, Inc., Sunnyvale, CA. This drawing is only conditionally issued, and neither receipt nor possession thereof confers or transfers any right in, or license to use, the subject matter of the drawing or any design or technical information shown thereon, nor any right to reproduce this drawing or any part thereof. Except for manufacture by vendors of Atari, Inc., and for manufacture under the corporation's written license, no right is granted to reproduce this drawing or the subject matter thereof, unless by written agreement with or written permission from the corporation.



A Warner Communications Company
Space Duel™

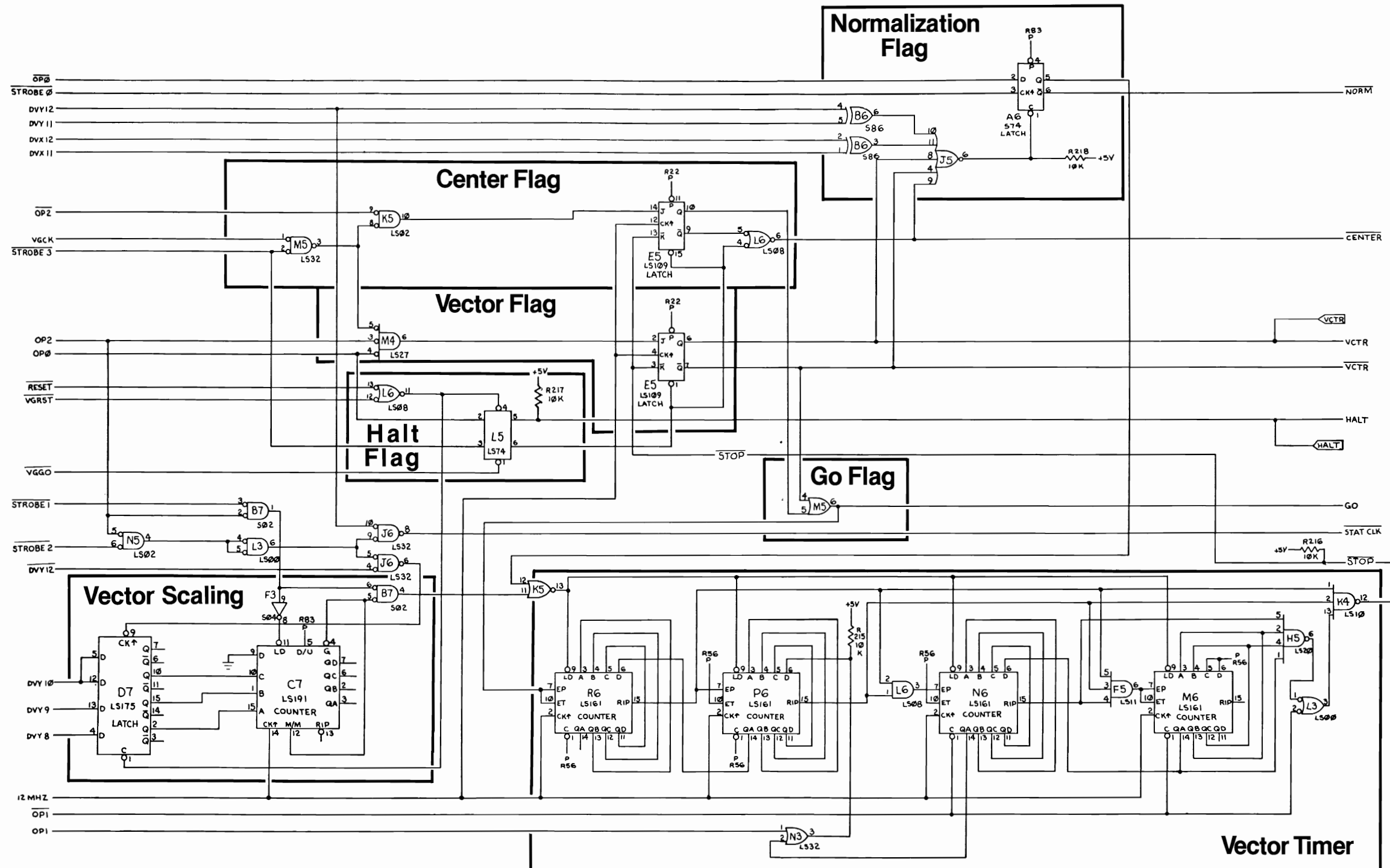

NOTICE TO ALL PERSONS RECEIVING THIS DRAWING
 CONFIDENTIAL: Reproduction forbidden without the specific written permission of Atari, Inc., Sunnyvale, CA. This drawing is only conditionally issued, and neither receipt nor possession thereof confers or transfers any right in, or license to use, the subject matter of the drawing or any design or technical information shown thereon, nor any right to reproduce this drawing or any part thereof. Except for manufacture by vendors of Atari, Inc., and for manufacture under the corporation's written license, no right is granted to reproduce this drawing or the subject matter thereof, unless by written agreement with or written permission from the corporation.



ATARI
 A Warner Communications Company

Space Duel™

© ATARI INC. 1982

Sheet 7B
 SP-181 1st printing

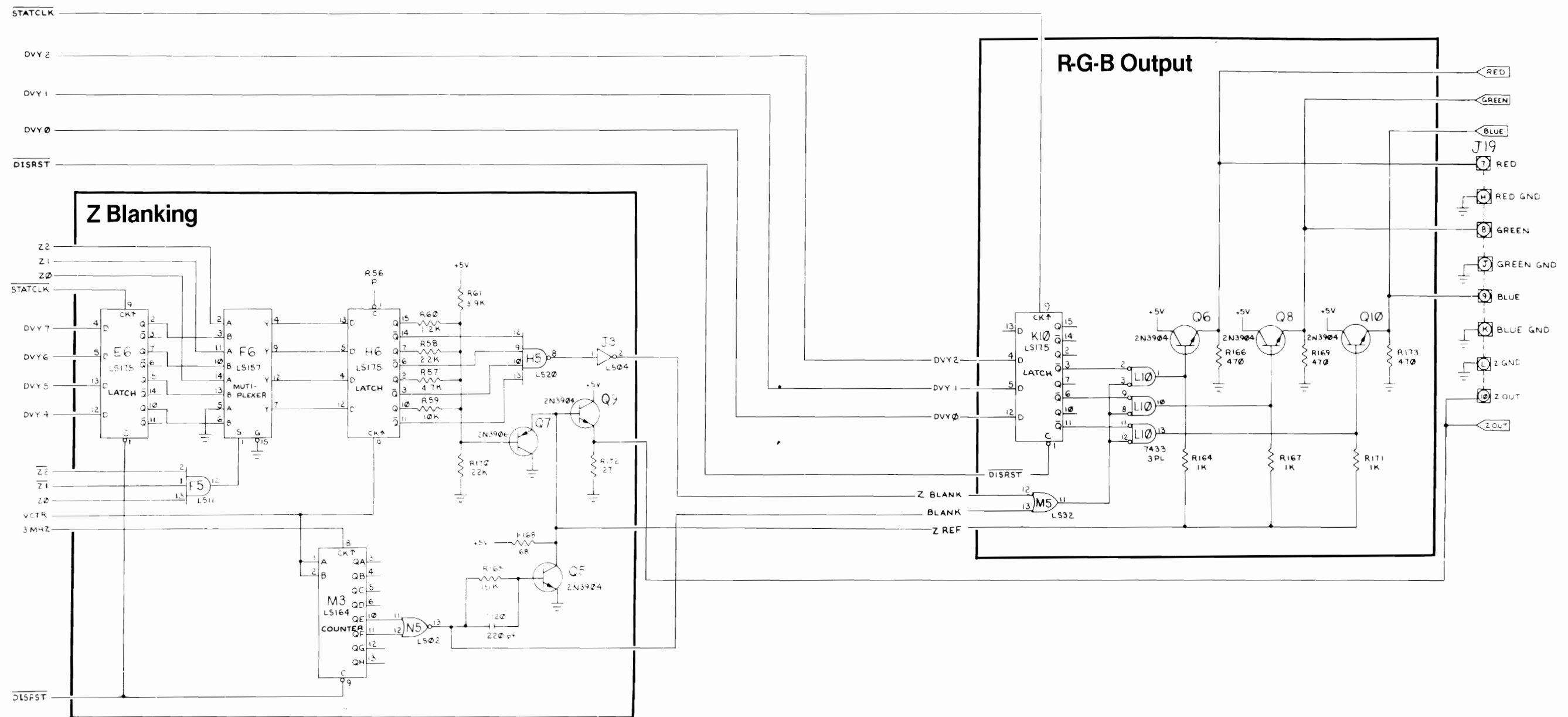

NOTICE TO ALL PERSONS RECEIVING THIS DRAWING
 CONFIDENTIAL: Reproduction forbidden without the specific written permission of Atari, Inc., Sunnyvale, CA. This drawing is only conditionally issued, and neither receipt nor possession thereof confers or transfers any right in, or license to use, the subject matter of the drawing or any design or technical information shown thereon, nor any right to reproduce this drawing or any part thereof. Except for manufacture by vendors of Atari, Inc., and for manufacture under the corporation's written license, no right is granted to reproduce this drawing or the subject matter thereof, unless by written agreement with or written permission from the corporation.



A Warner Communications Company

Space Duel™

CENTER

DVX12
DVX11
DVX10
DVX9
DVX8
DVX7
DVX6
DVX5
DVX4
DVX3
INVERT X

DAC Reference and Bipolar Voltage Sources

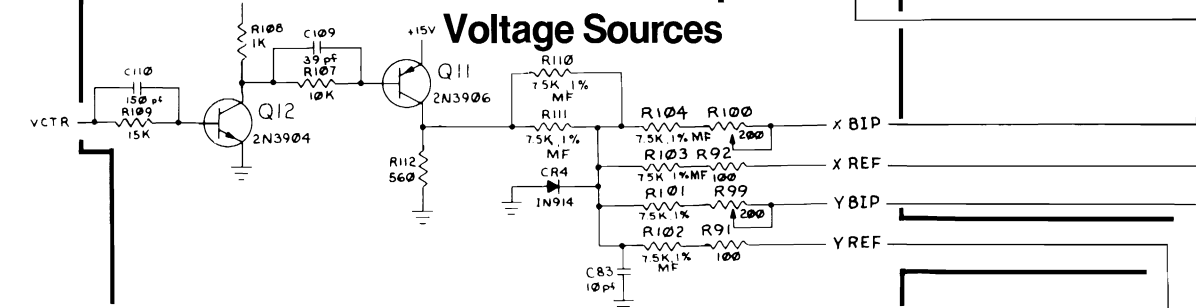

CENTER

DVY12
DVY11
DVY10
DVY9
DVY8
DVY7
DVY6
DVY5
DVY4
DVY3
INVERT Y

X-Axis Output

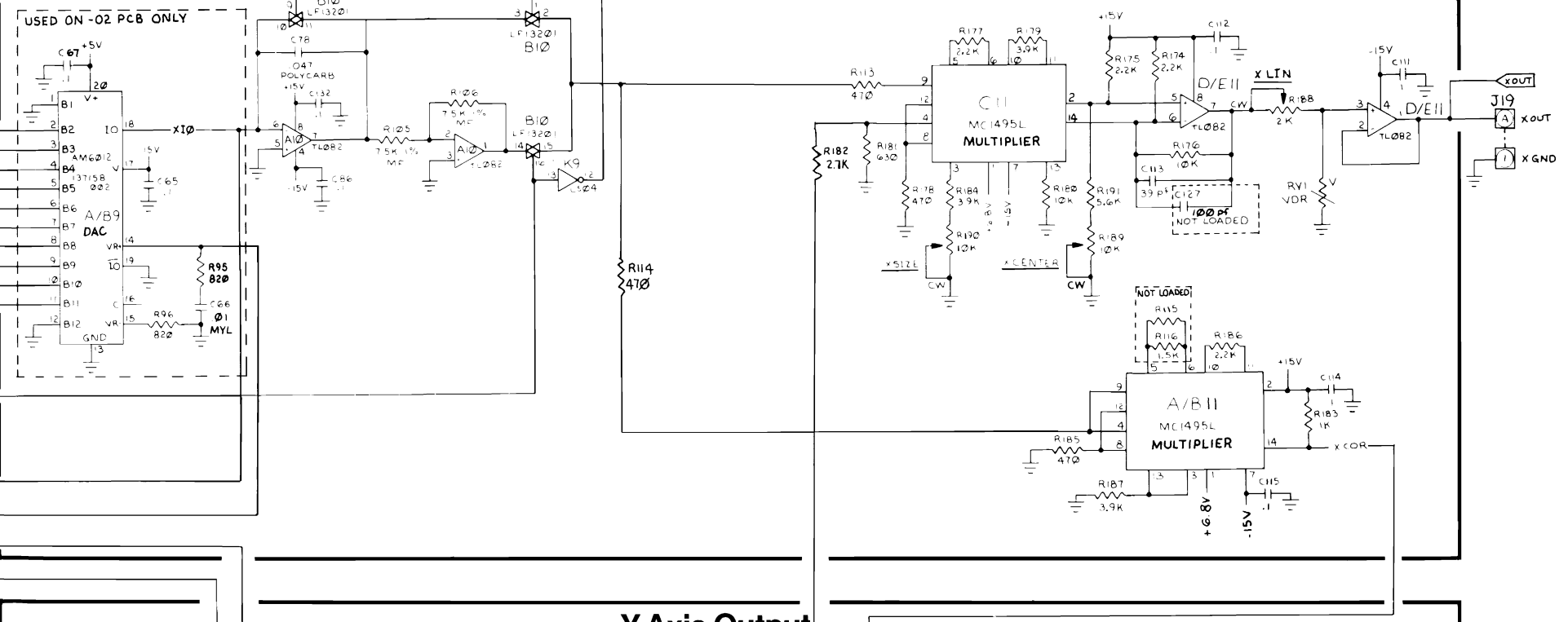

Y-Axis Output

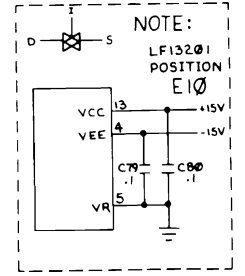
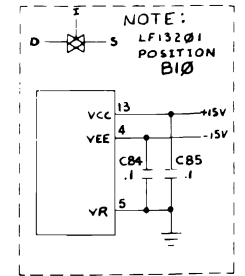
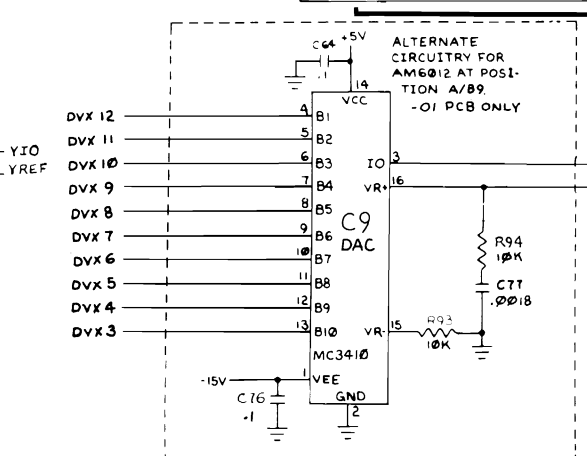
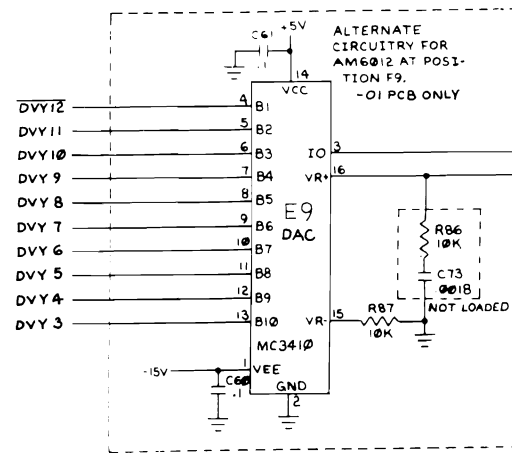
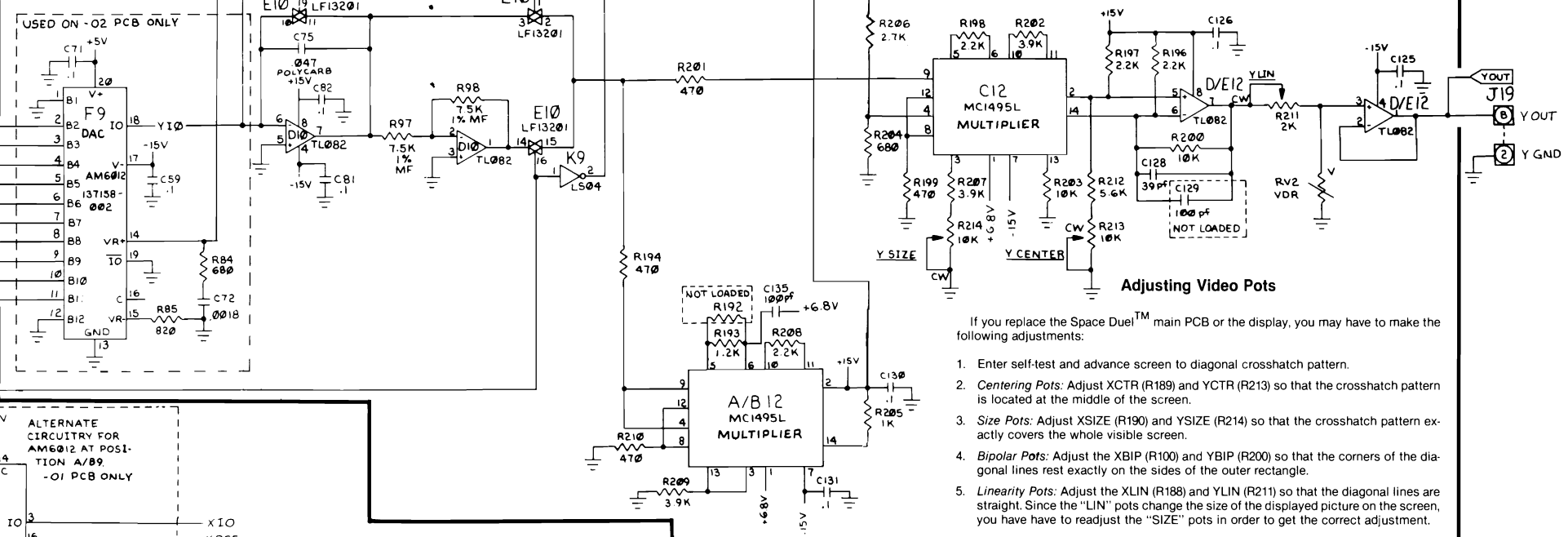

If you replace the Space Duel™ main PCB or the display, you may have to make the following adjustments:

1. Enter self-test and advance screen to diagonal crosshatch pattern.
2. **Centering Pots:** Adjust XCTR (R189) and YCTR (R213) so that the crosshatch pattern is located at the middle of the screen.
3. **Size Pots:** Adjust XSIZE (R190) and YSIZE (R214) so that the crosshatch pattern exactly covers the whole visible screen.
4. **Bipolar Pots:** Adjust the XBIP (R100) and YBIP (R200) so that the corners of the diagonal lines rest exactly on the sides of the outer rectangle.
5. **Linearity Pots:** Adjust the XLIN (R188) and YLIN (R211) so that the diagonal lines are straight. Since the "LIN" pots change the size of the displayed picture on the screen, you have to readjust the "SIZE" pots in order to get the correct adjustment.

Adjusting Video Pots

NOTICE TO ALL PERSONS RECEIVING THIS DRAWING
CONFIDENTIAL: Reproduction forbidden without the specific written permission of Atari, Inc., Sunnyvale, CA. This drawing is only conditionally issued, and neither receipt nor possession thereof confers or transfers any right in, or license to use, the subject matter of the drawing or any design or technical information shown thereon, nor any right to reproduce this drawing or any part thereof. Except for manufacture by vendors of Atari, Inc. and for manufacture under the corporation's written license, no right is granted to reproduce this drawing or the subject matter thereof, unless by written agreement with or written permission from the corporation.



Color X-Y Display Schematic Diagram

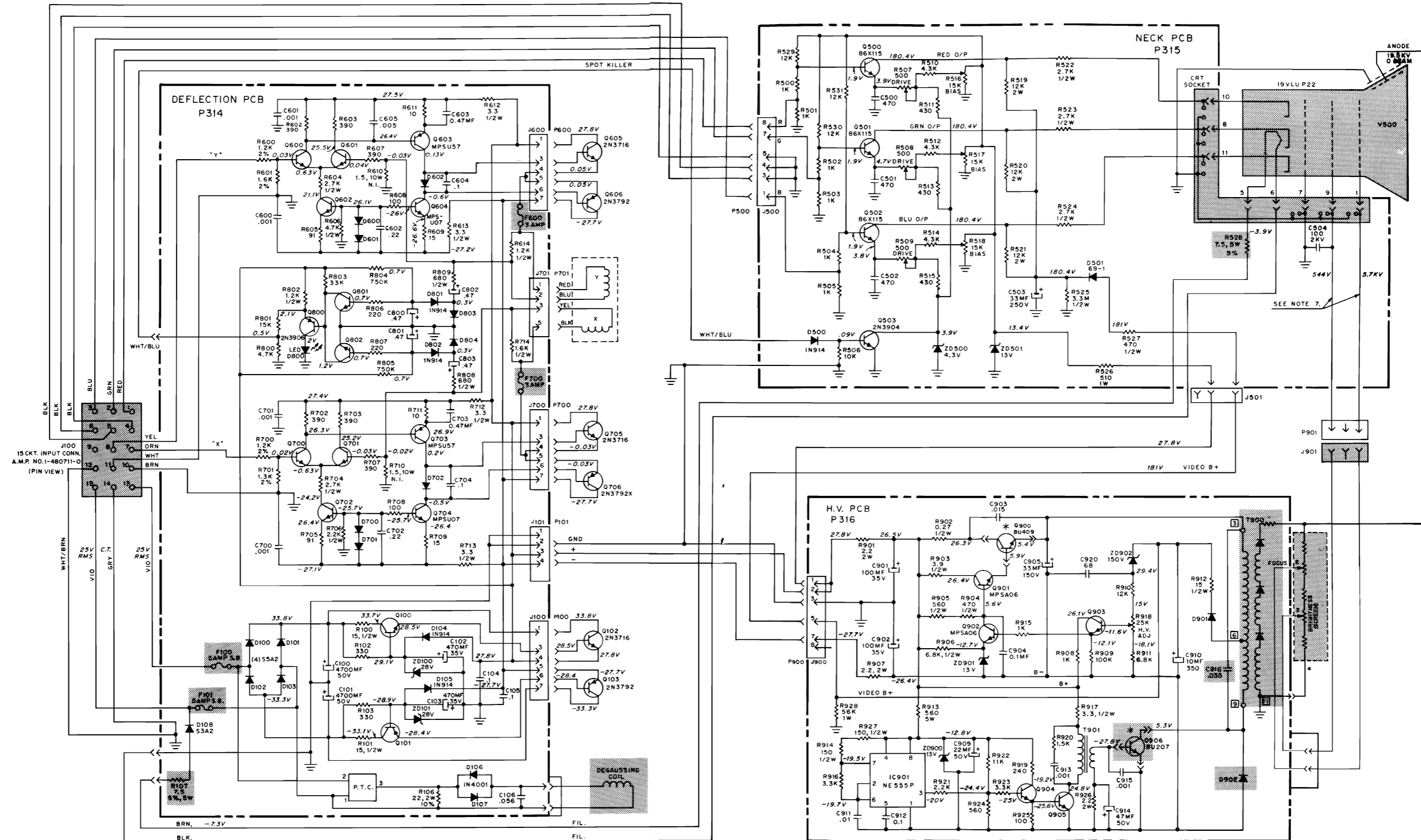

GENERAL NOTES

1. Resistance values in ohms, 1/4 watt, $\pm 5\%$, unless otherwise noted. K = 1,000, M = 1,000,000
2. Capacitance value of 1 or less is in microFarads, above 1 in picoFarads, unless otherwise noted.
3. * Q900 and Q906 are not in High-Voltage PCB.
4. All D.C. voltages are $\pm 10\%$ measured from point indicated to ground, using a high-impedance meter. Voltages are measured with no signal input and controls are in a normal operating position.
5. Circled numbers indicate location of waveform reading.
6. ZD100-101 uses (66X0040-007) zener diode in series with (340X2331-934) 330-ohm resistor in early production models.
7. Use a 1,000:1 probe when measuring G2 (screen) or focus voltage.



WARNING

Components identified by shading have special characteristics important to safety and should be replaced only with identical types.

NOTICE TO ALL PERSONS RECEIVING THIS DRAWING
 CONFIDENTIAL: Reproduction forbidden without the specific written permission of Atari, Inc., Sunnyvale, CA. This drawing is only conditionally issued, and neither receipt nor possession thereof confers or transfers any right in, or license to use, the subject matter of the drawing or any design or technical information shown thereon, nor any right to reproduce this drawing or any part thereof. Except for manufacture by vendors of Atari, Inc., and for manufacture under the corporation's written license, no right is granted to reproduce this drawing or the subject matter thereof, unless by written agreement with or written permission from the corporation.



Space Duel™

© ATARI INC. 1982

Sheet 9A
 SP-181 1st printing

Troubleshooting with the CAT Box

Memory Map

HEXA-DECIMAL ADDRESS	R/W	DATA								FUNCTION
		D7	D6	D5	D4	D3	D2	D1	D0	
0000-03FF		D	D	D	D	D	D	D	D	1K Program RAM0
0800	R	D								3 KHz Input HALT (1 = Halted) DIAG STEP Input (0 = On) Self-Test Input (0 = On) SLAM Input (0 = On) Utility Coin Input (0 = On) Left Coin Input (0 = On) Right Coin Input (0 = On)
0900	R	D								SHIELDS1 Input (1 = On) FIRE1 Input (1 = On)
0901	R	D								SHIELDS2 Input (1 = On) FIRE2 Input (1 = On)
0902	R	D								ROTATE LEFT1 (1 = On) ROTATE RIGHT1 (1 = On)
0903	R	D								ROTATE LEFT2 (1 = On) ROTATE RIGHT2 (1 = On)
0904	R	D								THRUST1 Input (1 = On) START Input (1 = On)
0905	R	D								THRUST2 Input (1 = On) Option Input (1 = On)
0906	R	D								GAME SELECT Input (1 = On) Option Input (1 = On)
0907	R	D								Cabinet Input (1 = Upright, 0 = Cocktail) Option Input (1 = On)
0A00	R	D	D	D	D	D	D	D	D	EAROMRD
0C00	W	D								INVERT Y (1 = Invert) INVERT X (1 = Invert) START LED (0 = On) SELECT LED (0 = On) Coin Lockout Output (0 = On) Left Coin Counter Right Coin Counter
0C80	W									VGG0
0D00	W									WDCLR
0D80	W									VGRST
0E00	W									INTACK
0E80	W				D					EAROM Con-CS1 EAROM Con-C1 (Inverted) EAROM Con-C2 EAROM Con-CK
0F00-0F3F	W	D	D	D	D	D	D	D	D	EAROMWR
1000-100F		D	D	D	D	D	D	D	D	Custom I/O 0 (Unfiltered)
1400-140F		D	D	D	D	D	D	D	D	Custom I/O 1 (Filtered)
2000-27FF		D	D	D	D	D	D	D	D	2K VRAM0-VRAM1
2800-3FFF	R	D	D	D	D	D	D	D	D	6K VROM1-VROM2
4000-87FF	R	D	D	D	D	D	D	D	D	20K Program ROM0-ROM4

Troubleshooting with the Read/Write Controller

A. CAT Box Preliminary Set-up

- Remove:**
 - The electrical power from the game.
 - The wiring harness from the game PCB.
 - The game PCB from the game cabinet.
 - The microprocessor chip C2 from the game PCB.
- Connect:**
 - The harness from the game to the game board. (Use extender cables if available.)
 - Φ0 and Φ2 test points together with the shortest possible jumper.
 - WDDIS test point to ground.
 - The CAT Box flex cable to the game PCB test edge connector.
- Power Up:**
 - The game.
 - The CAT Box.
- Set CAT Box Switches:**
 - TESTER SELF-TEST: (OFF)
 - TESTER MODE: R/W
 - Press TESTER RESET

B. Address and Data Lines

- Perform the CAT Box preliminary set-up.
- Connect the DATA PROBE to the CAT Box and the game ground test point.
- TESTER MODE: R/W
- BYTES: 1
- PULSE MODE: UNLATCHED
- R/W MODE: (OFF)
- R/W: WRITE
- Key in address pattern on the keyboard (*use AAAA to start*)
- Push DATA SET
- Key in data pattern on the keyboard (*use AA to start*)
- R/W MODE: STATIC
- Probe the IC-pin with the data probe and check for the 1 or 0 LED as indicated in Table 2-2. Repeat this step for each address and data line.
- Repeat steps 6-11 using 5555 in step 7 and 55 in step 9.

When writing AAAA pattern Logic State	Address and data lines IC-Pin	When writing 5555 pattern Logic State
1	R2-12	0
0	R2-13	1
1	R2-14	0
0	R2-15	1
1	B1-7	0
0	B1-12	1
1	B1-14	0
0	B1-16	1
1	C1-9	0
0	C1-7	1
1	C1-5	0
0	C1-3	1
1	C1-12	0
0	C1-14	1
1	C1-16	0
0	C1-18	1
1	F2-9	0
0	F2-8	1
1	F2-7	0
0	F2-6	1
1	F2-5	0
0	F2-4	1
1	F2-3	0
0	F2-2	1

C. RAM

- Perform the CAT Box preliminary set-up.
- Set the CAT Box switches as follows:
 - Press TESTER RESET
 - DBUS SOURCE: ADDR
 - BYTES: 1024
 - R/W MODE: (OFF)
 - R/W: WRITE
 - Enter 0000 on the keypad
 - Toggle R/W MODE to PULSE and back to (OFF)
 - R/W: READ
 - Toggle R/W MODE to PULSE and back to (OFF)
- If the CAT Box reads an address that doesn't compare, the COMPARE ERROR LED lights up, the ADDRESS/SIGNATURE display shows the failing address location, and the ERROR DATA DISPLAY switch is enabled. Using this switch, determine if the error is in the high-or low-order RAM.
- Repeat the test with DBUS SOURCE set to ADDR.
- Repeat steps 2-4, entering 2000 on the keypad (step f).
- Repeat steps 2-4, entering 2400 on the keypad (step f).

D. Option Switch Inputs

- Perform the CAT Box preliminary set-up.
- BYTES: 1
- R/W: WRITE
- R/W MODE: (OFF)
- Key in 100F
- Push DATA SET
- Key in 00
- R/W: READ
- R/W MODE: (OFF)
- Key in 100B
- R/W MODE: STATIC, then to (OFF)
- R/W: READ
- Key in 1008
- R/W MODE: STATIC
- Activate each option switch toggle at location D4 while monitoring the DATA display. The DATA display will change if the switches are operating properly.
- Repeat steps 3-14, entering 140B in step 5 and 1408 in step 10, and activate switches at location B4.

E. Custom Audio I/O Chips

NOTE

Space Duel™ has two custom audio I/O chips. Each must be tested separately. There are several ways to test the chips:

- Perform the self-test.
- Substitute good part for defective part.
- Use the procedure that follows.

- Perform the CAT Box preliminary set-up.
- BYTES: 1
- R/W: WRITE
- R/W MODE: (OFF)
- Enter address from Table 2-3
- Press DATA SET
- Enter the data from Table 2-3
- R/W MODE to PULSE and back to (OFF)
- Repeat steps 5-8 for each address and data, and note the test results.

NOTICE TO ALL PERSONS RECEIVING THIS DRAWING
CONFIDENTIAL: Reproduction forbidden without the specific written permission of Atari, Inc., Sunnyvale, CA. This drawing is only conditionally issued, and neither receipt nor possession thereof confers or transfers any right in, or license to use, the subject matter of the drawing or any design or technical information shown thereon, nor any right to reproduce this drawing or any part thereof. Except for manufacture by vendors of Atari, Inc., and for manufacture under the corporation's written license, no right is granted to reproduce this drawing or the subject matter thereof, unless by written agreement with or written permission from the corporation.



Space Duel™

Table 2-3 Custom Audio I/O Chips

ADDRESS	DATA	TEST RESULTS
100F	00	
100F	03	
1000	55	
1001	AF	Custom Audio I/O Chip #1 channel 1 produces pure tone.
1001	00	Custom Audio I/O Chip #1 channel 1 off.
1002	55	
1003	AF	Custom Audio I/O Chip #1 channel 2 produces pure tone.
1003	00	Custom Audio I/O Chip #1 channel 2 off.
1004	55	
1005	AF	Custom Audio I/O Chip #1 channel 3 produces pure tone.
1005	00	Custom Audio I/O Chip #1 channel 3 off.
1006	55	
1007	AF	Custom Audio I/O Chip #1 channel 4 produces pure tone.
1007	00	Custom Audio I/O Chip #1 channel 4 off.
140F	00	
140F	03	
1400	55	
1401	AF	Custom Audio I/O Chip #0 channel 1 produces pure tone.
1401	00	Custom Audio I/O Chip #0 channel 1 off.
1402	55	
1403	AF	Custom Audio I/O Chip #0 channel 2 produces pure tone.
1403	00	Custom Audio I/O Chip #0 channel 2 off.
1404	55	
1405	AF	Custom Audio I/O Chip #0 channel 3 produces pure tone.
1405	00	Custom Audio I/O Chip #0 channel 3 off.
1406	55	
1407	AF	Custom Audio I/O Chip #0 channel 4 produces pure tone.
1407	00	Custom Audio I/O Chip #0 channel 4 off.

F. Player and Option Switch P10/11 Inputs

1. Perform the CAT Box preliminary set-up.
2. BYTES: 1
3. R/W: READ
4. For each address of Table 2-4, do the following:
R/W MODE: (OFF)
Enter address
R/W MODE: STATIC
Activate input switch for address.

Table 2-4 Player and DIP Switch Inputs

ADDRESS	INPUT SWITCH	TEST RESULTS
0800	Right coin switch Left coin switch Self-test switch Slam switch	Lower nybble (right digit) of DATA display changes when right or left coin, or self-test switches are activated. Upper nybble of DATA display is unstable, but has noticeable change when slam switch is activated.
0900	SHIELDS, Player 1 FIRE, Player 1	Upper nybble of DATA display changes when each input switch is activated.
0901	SHIELDS, Player 2 FIRE, Player 2	Upper nybble of DATA display changes when each input switch is activated.
0902	ROTATE LEFT, Player 1 ROTATE RIGHT, Player 1	Upper nybble of DATA display changes when each input switch is activated.
0903	ROTATE LEFT, Player 2 ROTATE RIGHT, Player 2	Upper nybble of DATA display changes when each input switch is activated.
0904	THRUST, Player 1 START	Upper nybble of DATA display changes when each input switch is activated.
0905	THRUST, Player 2 DIP switch at location P10/11, toggle 4	Upper nybble of DATA display changes when each input switch is activated.
0906	GAME SELECT DIP switch at location P10/11, toggle 3	Upper nybble of DATA display changes when each input switch is activated.
0907	Connector J20, pin R DIP switch at location P10/11, toggle 2	Upper nybble of DATA display changes when J20-R is grounded and ungrounded, or when DIP switch P10/11 toggle 2 is set to <i>on</i> and <i>off</i> .

G. Analog Vector-Generator

1. Test

1. Perform the CAT Box preliminary set-up.
2. DATA SOURCE: DATA
3. R/W: WRITE
4. R/W MODE: (OFF)
5. Key in address from Table 2-5 or press ADDRESS INCR.
6. Press DATA SET
7. Key in data from Table 2-5
8. Set R/W MODE to PULSE and then to (OFF)
9. Repeat steps 5-8 for each address in Table 2-5

CAUTION

You may damage the circuitry of the X-Y display if you key in the VGGO signal without first checking all the addresses and data. Check the data by reading each address location using steps 10-14:

10. R/W: READ
11. R/W MODE: (OFF)
12. Key in address or press ADDRESS INCR.
13. R/W MODE: PULSE
14. Check the data in the DATA display against the data in Table 2-5.

If you are sure the data is correct, proceed to steps 15-19:

15. R/W MODE: WRITE
16. R/W: (OFF)
17. Key in VGGO address 0C80
18. R/W to PULSE and then back to (OFF)
19. After writing to the VGGO address, the screen should show a large plus sign. Failure of the horizontal or vertical circuits shows up as a single line drawn on the screen. *If the screen does not display a large plus sign, contact Atari Field Service.*

Table 2-5 Analog Vector-Generator Data

ADDRESS	DATA	ADDRESS	DATA
2000	00	200C	00
2001	70	200D	21
2002	40	200E	80
2003	80	200F	1F
2004	77	2010	80
2005	64	2011	1F
2006	00	2012	00
2007	00	2013	01
2008	80	2014	00
2009	1F	2015	20
200A	00	2016	00
200B	00	2017	E0

H. LED, Coin Counter and Invert Outputs

1. Perform the CAT Box preliminary set-up.
2. DBUS SOURCE: DATA
3. BYTES: 1
4. R/W: WRITE
5. R/W MODE: (OFF)
6. Enter address 0C00

CAUTION

If you write ON data to activate a solenoid, deactivate the solenoid immediately by writing the OFF data. If you leave a solenoid activated for more than 10 seconds, you may have to replace the solenoid and/or its driver, due to overheating.

7. For each DATA output of Table 2-6, do the following:

- a. To activate output:
 - Press DATA SET
 - Enter ON-DATA for desired output
 - R/W MODE: STATIC, then (OFF)
- b. To deactivate output:
 - Press DATA SET
 - Enter OFF-DATA of activated output
 - R/W MODE: STATIC, then (OFF)

Table 2-6 LED and Coin Counter Outputs

Key in address 0C00 for the seven outputs below.

ON-DATA	OFF-DATA	OUTPUT DEVICE
39	38	Right Coin Counter
3A	38	Left Coin Counter
30	38	Coin Door Lockout
28	38	GAME SELECT LED
18	38	START LED
78	38	INVERTX*
B8	38	INVERTY**

*When INVERTX is activated, check for logic 1 on pin 16 of IC B10.

**When INVERTY is activated, check for logic 1 on pin 16 of IC E10.

NOTICE TO ALL PERSONS RECEIVING THIS DRAWING
CONFIDENTIAL: Reproduction forbidden without the specific written permission of Atari, Inc., Sunnyvale, CA. This drawing is only conditionally issued, and neither receipt nor possession thereof confers or transfers any right in, or license to use, the subject matter of the drawing or any design or technical information shown thereon, nor any right to reproduce this drawing or any part thereof. Except for manufacture by vendors of Atari, Inc., and for manufacture under the corporation's written license, no right is granted to reproduce this drawing or the subject matter thereof, unless by written agreement with or written permission from the corporation.



Space Duel™

Troubleshooting with Signature Analysis

A. Signature Analysis Set-up

1. Perform the CAT Box preliminary set-up.
2. Connect the three BNC to E-Z clip cables (supplied with the CAT Box) to the SIGNATURE ANALYSIS CONTROL START, STOP and CLOCK jacks on the CAT Box.
3. Attach the three black E-Z clips to a ground loop on the Space Duel™ game PCB.
4. Attach the CAT Box data probe to the DATA jack on the CAT Box.
5. The colored E-Z clips on the cables will be moved about for each group of signatures to be taken.
6. Set the CAT Box switches as follows:
 - TESTER MODE: SIG
 - TESTER SELF-TEST: OFF
 - PULSE MODE: LATCHED
 - START: As indicated
 - STOP: As indicated
 - CLOCK: As indicated
7. Power up the game board and the CAT Box.

B. Address Lines

1. CAT Box Settings for Address Bus Test

Probe	Trigger	IC-Pin	Test Pt.
Start	$\overline{\text{L}}$	R2-12	
Stop	$\overline{\text{L}}$	R2-12	
Clock	$\overline{\text{L}}$	C2-39	$\phi 2$

Verify CAT Box settings and connections as follows:

- probe GND test point = 0000 signature
- probe +5V test point = 0001 signature

2. Signatures

Logic Probe on IC-Pin	Signal Name	Signature Should Be
C1-18	AB0	UUUU
C1-16	AB1	5555
C1-14	AB2	CCCC
C1-12	AB3	7F7F
C1-3	AB4	5H21
C1-5	AB5	0AFA
C1-7	AB6	UPFH
C1-9	AB7	52F8
B1-16	AB8	HC89
B1-14	AB9	2H70
B1-12	AB10	HPP0
B1-7	AB11	1293
B1-5	AB12	HAP7
R2-14	A13	3C96
R2-13	A14	3827
R2-12	A15	755U

C. Address Decoder

CAUTION

While testing decoders and ROMs, it may be necessary to add 270 pF capacitors to ADDR 12, 13, 14 and 15 to eliminate unstable signatures.

1. CAT Box Settings for Address Decoder Test

Probe	Trigger	IC-Pin	Test Pt.
Start	$\overline{\text{L}}$	R2-12	
Stop	$\overline{\text{L}}$	R2-12	
Clock	$\overline{\text{L}}$		$\phi 2$

2. Signatures

Verify CAT Box settings and connections as follows:

- probe GND test point = 0000 signature
- probe +5V test point = 0001 signature

Logic Probe on IC-Pin	Logic Probe on Test Pt.	Signal Name	Signature Should Be
R2-2			7631
R2-1			383A
R3-6			4P0A
R2-4			04UH
R2-3			160U
	$\overline{\text{V}}\text{MEM}$	$\overline{\text{V}}\text{MEM}$	12U3
	$\overline{\text{R}}\text{OM0}$	$\overline{\text{R}}\text{OM0}$	CFHH
	$\overline{\text{R}}\text{OM1}$	$\overline{\text{R}}\text{OM1}$	57HH
	$\overline{\text{R}}\text{OM2}$	$\overline{\text{R}}\text{OM2}$	96F8
	$\overline{\text{R}}\text{OM3}$	$\overline{\text{R}}\text{OM3}$	546U
	$\overline{\text{R}}\text{OM4}$	$\overline{\text{R}}\text{OM4}$	755P
H3-10		$\overline{\text{R}}\text{OM}$	5FU9

Jumper $\overline{\text{R}}/\overline{\text{W}}$ test point to +5V test point.

Logic Probe on IC-Pin	Signal Name	Signature Should Be
K6-12	$\overline{\text{S}}\text{INP1}$	U14U
K6-11	$\overline{\text{S}}\text{INP2}$	HF1A
K6-10	$\overline{\text{E}}\text{AROMRD}$	UOHA
P3-1	$\overline{\text{R}}\text{AM0}$	51FP
P3-2	$\overline{\text{R}}\text{AM1}$	6C23
P3-3		587H
P3-4		5AAC
P3-5	$\overline{\text{I}}\text{O0}$	C787
P3-6	$\overline{\text{I}}\text{O1}$	9UAP
R3-11	$\overline{\text{I}}\text{O5}$	2828

Remove jumper between $\overline{\text{R}}/\overline{\text{W}}$ test point and +5V test point.

NOTE

If you are taking signatures on a PCB connected to a game, disconnect the connector to the coin counter(s). The coin counter will energize while K4-6 is connected to ground.

Jumper $\overline{\text{WRITE}}$, K4-6, to GND test point.

Logic Probe on IC-Pin	Signal Name	Signature Should Be
M5-8		5AAC
L4-1	$\overline{\text{O}}\text{UTPUT}$	C9FU
L4-2	$\overline{\text{V}}\text{GGO}$	258A
L4-3	$\overline{\text{W}}\text{DCLR}$	4C6C
L4-4	$\overline{\text{V}}\text{GRST}$	7079
L4-5	$\overline{\text{I}}\text{NTACK}$	F425
L4-6	$\overline{\text{E}}\text{AROMCON}$	6175
L4-7	$\overline{\text{E}}\text{AROMWR}$	HAU2

D. ROM and Data Lines

We are providing only the signatures for ROM4. This ROM contains the self-test procedure that tests all the other ROMs and displays a number representing a ROM failure.

NOTE

When taking signatures of ROM4, install 270 pF capacitors between IC R2, pin 12 and ground and IC R2, pin 14 and ground.

1. CAT Box Settings for ROM4 Test (I.C. J1 for ROM part no. 136006-201)

Probe	Trigger	Test Pt.
Start	$\overline{\text{L}}$	ROM4
Stop	$\overline{\text{L}}$	ROM4
Clock	$\overline{\text{L}}$	$\phi 2$

Verify CAT Box settings and connections as follows:

- probe GND test point = 0000 signature
- probe +5V test point = 755U signature

2. Signatures

Logic Probe on IC-Pin	Signal Name	Signature Should Be
J1-9	D0	46A2
J1-10	D1	0325
J1-11	D2	10H5
J1-13	D3	P228
J1-14	D4	9FP1
J1-15	D5	5U58
J1-16	D6	C57C
J1-17	D7	2C95

Watchdog

The Watchdog circuit will send continuous reset pulses to the microprocessor if a problem exists within the microprocessor circuit. If the self-test fails to run, it is a good practice to check the reset line.

$\overline{\text{RESET}}$ is a microprocessor input (pin 40). In a properly operating game, reset should occur during power-up or when the reset pushbutton is activated. A pulsing $\overline{\text{RESET}}$ line indicates that something is causing the microprocessor to lose its place within its program. Typical causes are:

1. Open or shorted address or data bus lines
2. Bad microprocessor chip
3. Bad bus buffers
4. Bad ROM
5. Bad RAM
6. Any bad input or output that causes an address or data line to be held in a constant high or low state

A pulsing $\overline{\text{RESET}}$ signal indicates a problem exists somewhere within the microprocessor circuitry rather than within the Analog Vector-Generator.



A Warner Communications Company

Space Duel™

NOTICE TO ALL PERSONS RECEIVING THIS DRAWING
CONFIDENTIAL: Reproduction forbidden without the specific written permission of Atari, Inc., Sunnyvale, CA. This drawing is only conditionally issued, and neither receipt nor possession thereof confers or transfers any right in, or license to use, the subject matter of the drawing or any design or technical information shown thereon, nor any right to reproduce this drawing or any part thereof. Except for manufacture by vendors of Atari, Inc., and for manufacture under the corporation's written license, no right is granted to reproduce this drawing or the subject matter thereof, unless by written agreement with or written permission from the corporation.