

This document has been downloaded from:



The largest resource for amusement machines
documentation on the world wide web!



FLIPPERSPILL.COM

DragRace™

KG
KEE GAMES

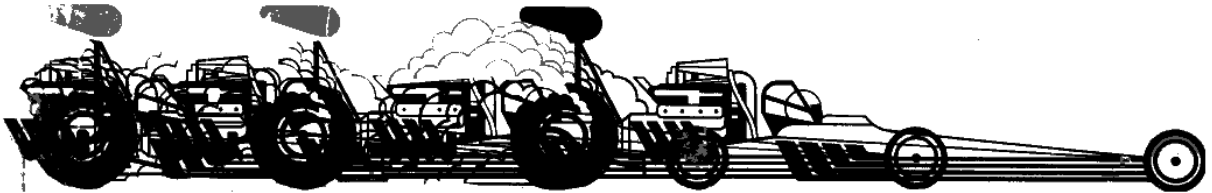
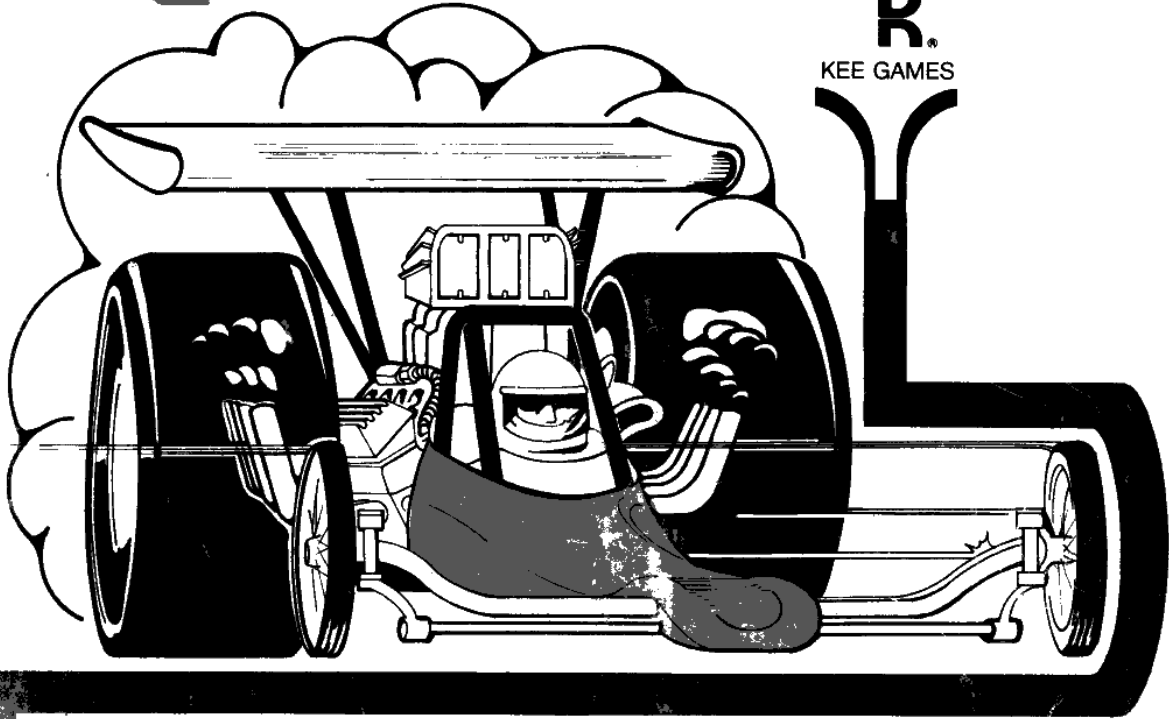

Operation, Maintenance and Service Manual

DragRace™

Operation, Maintenance and Service Manual

ATARI INC
1265 BORREGAS AVENUE
SUNNYVALE, CALIFORNIA 94086
408/745-2000 ■ TELEX 35-7488

By the Publications Group, Engineering Department



KEE GAMES
a wholly
owned subsidiary
of Atari, Inc.

 A Warner Communications Company

TABLE OF CONTENTS

1 LOCATION SETUP	
A. INTRODUCTION	1
B. INSTALLATION INSTRUCTIONS	4
Unpacking and Examination for Shipping Damage	4
Mechanical Inspection	4
C. ADJUSTING OPERATOR OPTIONS	4
Check on Interlock Switch	4
Changing the Options	4
D. PERFORMING THE SELF-TEST	6
2 GAME PLAY	
A. GENERAL GAME SEQUENCE	9
B. OPERATING MODES	10
Attract Mode	10
Play Mode	11
3 MAINTENANCE AND ADJUSTMENTS	
A. CLEANING	14
B. ADJUSTMENTS ON TV MONITOR	14
C. ADJUSTMENTS OF BOTH SPEAKER VOLUMES	15
D. ADJUSTMENTS OF BOTH SOUND PITCHES AND TACHOMETERS	15
E. ADJUSTMENT FOR GAME PLAY WITH ONE SET OF CONTROLS	15
F. COIN MECHANISM ADJUSTMENTS	17
4 THEORY OF OPERATION	
A. GENERAL INFORMATION	23
B. SYNC AND POWER CIRCUITRY	25
Clock Generator	25
Sync Countdown Chains	25
Power Supplies	25
C. MICROCOMPUTER SYSTEM	25
Microprocessor	25
Microcomputer Watchdog	25
DIAG Signal	26
HALT Signal	26
D. PROGRAM MEMORY	26
Program PROMs	26
Program PROMs Enable	26
Page Zero Memory	26
Page Zero Enable	26
E. MEMORY CIRCUITRY	26
Position Memory	26
Playfield Memory	27
Tri-State Devices	27
F. VIDEO CIRCUITRY	27
Object Memory	27
Video Serializing	27

Video Summing	27
G. INPUT/OUTPUT CIRCUITRY	27
Switch Sensing	27
Steering Sensing	51
Line Test Gating	51
Latch Group	51
H. SOUND CIRCUITRY	51
Noise Generator	51
Motor Sound Generators	51
Sound Mixing	51
Output Drive Stages	52

LIST OF ILLUSTRATIONS

Figure 1	Final Assembly	3
Figure 2	Approximate Locations of Option Switches and Sound Pitch, Tachometer and Volume Pots	7
Figure 3	TV Screen Display during Self-Test	8
Figure 4	Typical TV Picture at Start of Race Heat (Shows Premature Start)	11
Figure 5	Typical TV Picture During Play	12
Figure 6	Typical TV Picture at End of Race Heat	12
Figure 7	Locations of Adjustments on TV Chassis	14
Figure 8	Dashboard Assembly	17
Figure 9	Coin Door Assembly	17
Figure 10	Hinging Open the Magnet Gate Assembly	18
Figure 11	Removal of Coin Mechanism	18
Figure 12	Surfaces to Clean Inside the Coin Mechanism	18
Figure 13	Removal of Plate Covering Rear of Coin Slot	19
Figure 14	Close-Up View of Lubrication Point	19
Figure 15	Detail View of Coin Switch and Trip Wire	19
Figure 16	Adjustments on Coin Mechanism	20
Figure 17	Functional Block Diagram of "Drag Race" Game	24
Figure 18	Steering Wheel Assembly	28
Figure 19	Steering PCB Assembly	29
Figure 20	Game PCB Schematic Diagram (7 sheets)	31
Figure 21	Game PCB Assembly Drawing and Parts List	45
Figure 22	Harness Schematic	49
Figure 23	Motorola TV Monitor Schematic Diagram	50

LIST OF TABLES

Table 1	Game Specifications	5
Table 2	Settings on Option Switches	6
Table 3	Locations of Memory Failures	7

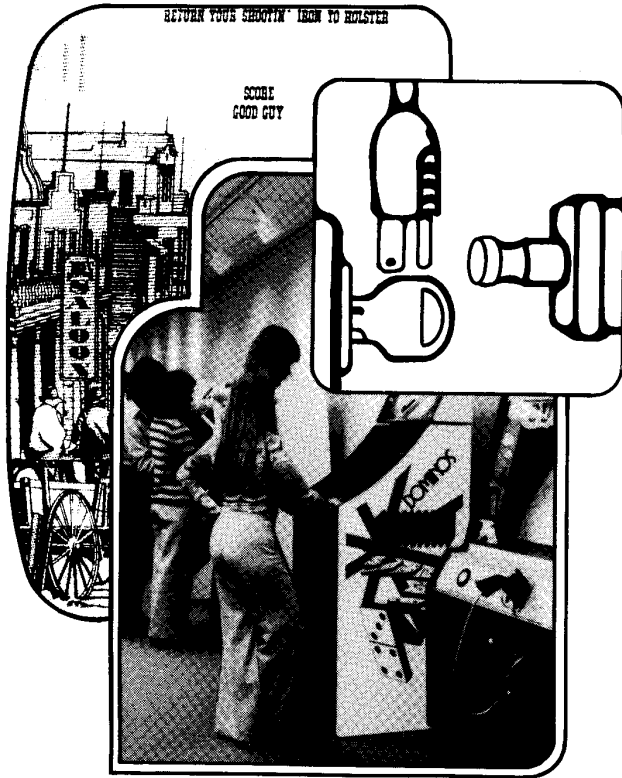

LOCATION SETUP

A. INTRODUCTION

Keegan Games' Drag Race™ is a skill-based video action game designed for one or two players. The game is packaged in its own distinctively-styled cabinet that rests directly on the floor. During game operation two dragster car figures appear on the screen of a 23-inch black-and-white TV monitor mounted at the top front of the cabinet. An overlay of colored transparent material is affixed to the glass on the face of the TV tube. During play the overlay filters light coming from the screen so that portions of the TV picture will appear highlighted in color. The players stand in front of the cabinet, watching the cars. Figure 1 shows an external view of the cabinet.

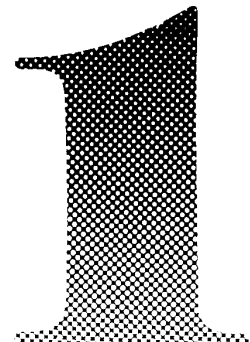

Item	Part Number	Qty.	Description
40	75-2112S	4	Screw, Mach., Pan. Hd., 10-24 x 3/4" Lg.
41	A007784-03	1	Strain Relief Power Cord
42	75-5532N	2	Bolt Carriage, 1/2-20 x 2.00" Lg.
43	TW-061	1	Technical Manual
44	006305-01	1	Printed Poly Bag
45	72-6610	12	Screw, Sm. #6 x 5/8" Lg. Phil., Pan Hd.
46	78-25001	1	Screw Down Tie Wrap
47	006319-02	1	Copyright Decal
48	A008714-01	1	Power Switch Harness
49	A006449-01	1	On-Off Switch Assembly
50	46-202302	2	Fuse 3 AMP (Slow)
51	008964-01	1	Formed Top w/Graphics

Item	Part Number	Qty.	Description
1	A005632-01	1	Cabinet Assembly with Graphics
2	A005662-01	1	Dashboard Assembly
3	A005667-01	1	T.V. Shelf Assembly
4	A005925-01	1	Electronics Tray Assembly
5	A005912-02	Ref.	R.F. Shield Box Assembly
6	A003637-11	1	Coin Door Assembly
7	A005495-02	1	24" Fluorescent Fixture Assembly
8	A006284-01	2	Single Foot Pedal Assembly
9	006814-01	1	Bezel, Card Board With Graphics
10	005701-01	1	Shield, Display Light (Silkscreen)
11	005665-01	2	Plex Retainers
12	001638-01	2	Panel MTC. Bracket
13	005419-02	2	Speaker Grill
14	73-77004	8	Rivets, 3/16" O.D. x .68 Lg.
15	75-931	2	Wingnuts, #10-24
16	48-001	2	8" Speaker
17	82-1824	6	Wood Screw, #8 x 1.25" Lg., Flat Hd. Phil.
18	A005410-01	1	Rear Door Assembly
19	A006318-01	1	R.F. Shield Assembly (PCB)
20	75-5120B	6	Bolt, Carriage, 10-24 x 1.25" Lg. Black
21	75-010S	8	#10 Washer, Flat
22	75-040	6	#10 Washer, Split-Lock
23	75-911S	6	#10-24 Nut, Hex
24	75-5520N	2	Bolt Carriage #1-20 x 1.25" Lg.
25	75-015S	4	Washer, Flat, 1/2"
26	75-045	6	Washer, Split Lock, 1/2"
27	75-915S	4	Nut, Machine Hexagon, 1/2-20
28	75-99090006	8	Well Nut, Blind Hole Fastener 10-32
29	82-8016	8	Screw, Button Hd. Socket Cap, 10-32 x 1.00" Lg.
30	72-6812	14	Screw, Self-Tapping #8 x 3/4 Lg., Phil., Pan Hd.
31	A005707-01	1	P.C. Board Assembly, Drag Race
32	005233-01	1	Rear Door Seal
33	68-002	1	Interlock Switch, A.C. Power
34	000268-02	1	Interlock Switch Bracket
35	72-6608	13	Screw, SM., Pan Hd., Phil., #6 x 1/4" Lg.
36	78-6601216	A/R	Alum. Foil
37	A005930-XX	1	Shipping Container
38	72-6808	1	Screw, Sm., #8 x 1/4 Lg. Ph. Pan. Hd.
39	75-935	2	Wing-Nut, 1/2-20

Each player operates a set of car controls; those near the right side of the cabinet are for the upper car on the TV screen, and those near the left are for the lower car. Two gas pedals, mounted at the bottom of the cabinet near each side, provide the foot-operated portions of the car controls. The hand-operated controls are all located on a dashboard assembly that is mounted on the front of the cabinet, just below the TV screen. For each player they consist of a steering wheel, a tachometer, and a gearshift lever. The lever has "neutral" and four gear positions. And to the right of each tachometer two backlighted start push buttons are provided. A player must depress one of them in order to start off a play sequence.

Two speakers are mounted below the dashboard assembly, one near each side of the cabinet. During play they produce a variety of sounds that add to the game excitement. Two identical coin mechanisms also are mounted below the dashboard, at the center of the cabinet. They accept quarters only and are connected so that either can initiate play. The cash box is located behind a locked access door to the coin mechanisms.

B. INSTALLATION INSTRUCTIONS

Unpacking and Examination for Shipping Damage:

Before shipment from the factory, components and sub-assemblies of each game are carefully checked for proper operation. However, during shipment some adjustments may have changed or parts may have been damaged. Upon initial removal of the game from the shipping container, first examine the exterior of the cabinet. Then open the rear (or side) access panel and also examine the interior. Any shipping damage such as a dented, cracked or broken cabinet, sub-assemblies broken loose, etc., should be reported immediately to the shipper and to Atari, Inc.

Mechanical Inspection:

After determining that the game has been received in good condition, carefully inspect the interior parts and verify the following:

- (a) All slip-on and plug-in connectors are firmly seated (particularly the PCB edge connector)
- (b) The fuses are all seated in their holders
- (c) No loose foreign objects are present (especially metal objects which could cause electrical short circuits)
- (d) No harness wires have become disconnected or pulled loose.

Be sure *all* major assemblies have been checked: TV monitor chassis, game printed circuit board inside the metal shielding box and its outside edge connector, gas pedal switches, coin mechanisms, speakers, underside of player control panel (tachometers, push buttons, shift lever assemblies, steering wheel assemblies including the small steering printed circuit board on each assembly), and the fluorescent lamp assembly at the top of the cabinet.

Do not go on to the remaining paragraphs in this section until the above mechanical inspection has been thoroughly performed.

C. ADJUSTING OPERATOR OPTIONS

Check on Interlock Switch:

The interlock switch is a safety switch mounted inside the game cabinet near the bottom edge of the rear access panel. At the factory this switch is mechanically adjusted so that it will automatically transfer to its "off" position (switch contacts "open") whenever the panel is opened. When the interlock switch is in its "off" position, the AC power leading to the game's power supply is interrupted. When the panel is closed, the interrupt switch is adjusted to be in the "on" position (switch contacts "closed") and AC power is allowed to reach the game's power supply, meaning that the game can operate.

After applying AC power, correct operation of the access panel interlock switch can be checked as follows: unlock and slowly open the panel. The correct response is that by the time the edge of the panel has moved about 2 to 3 inches away from the cabinet the TV screen should go dark, verifying that the interlock switch has automatically transferred to "off." While opening the panel do not insert fingers inside the cabinet and do not allow foreign objects to fall inside. If the TV screen continues to be lighted up even after the panel has been opened, immediately close and lock it and unplug the power cord from the wall outlet. Then refer to Section VI of this manual to replace and/or adjust the interlock switch.

Do not go on to the remaining paragraphs in this subsection until the operation of the interlock switch has been checked and found to be correct.

Changing the Options

The Drag Race game has three options which the operator can adjust at the game site in order to structure the play sequence, that is, to change some

Table 1 Game Specifications

GENERAL	
Cabinet Dimensions:	Height 64 in., Width 36 in., Depth 28 in.
TV Monitor:	Motorola Model XM701-10, black and white, with 23-inch screen.
Coin Mechanisms:	Two identical mechanisms (connected in parallel); accept quarters only.
Cash Box:	Removable; located behind locked access door to coin mechanism assembly.
Power Cord:	Approximately 6 ft. long, extending from rear of cabinet and having grounded three-prong plug for conventional wall outlets.
ELECTRICAL	
Power Requirement:	Uses conventional wall outlet providing 60-cycle AC (60 Hz, single phase) at 110 volts; power consumption rated at 140 watts.
Fusing:	All fuses located inside cabinet; TV monitor has two 1-amp fuses and remainder of game is protected by a 3-amp slow-blow fuse.
Power Interrupt Switch:	Cabinet has one switch located inside cabinet at access panel on rear. This is a safety switch that interrupts AC power to the game whenever the panel is unlocked and opened.
ENVIRONMENTAL	
Operating and Storage Temperature Range:	From 32°F to 120°F (<i>ambient temperature</i>)
Relative Humidity:	From 0% to 80% <i>without</i> condensation
OWNER/OPERATOR OPTIONS FOR STRUCTURING OF PLAY	
Game Cost:	Four choices, ranging from free play to 2 coins/player.
Number of Heats:	Three choices, from as few as 3 to as many as 5.
Extended Play:	Choice of no bonus play, or bonus play for any of three choices of elapsed time. NOTE: A speaker volume adjustment is also provided for each speaker.
ACCESSORIES AVAILABLE ON SEPARATE ORDER	
Video Probe:	Order from Atari
Universal Test Fixture:	Order from Atari, Catalog No. TF-101

of the game rules or the duration of play. These options consist of 6 two-position switches located on the game printed circuit board inside the cabinet. Table 2 shows the switch settings required to implement the desired options.

Game Cost Option. Two switches allow any one of four cost choices: 2 plays for 25c (either 2 one-player games or 1 two-player game), 25c per player, two coins per player, or free play (no coins required—used mainly for demonstrations).

Number of Heats Option. Two other switches give these three choices: 3, 4, or 5 heats per play sequence.

Bonus (Extended) Play Option. The settings on these two switches give a choice of no bonus play, or else bonus play if a player achieves any one of three score levels. The bonus play consists of one additional heat, based on a comparison of both *BEST TIME* scores with the selected bonus level setting.

Table 2 Settings on Option Switches

Option	Switch Numbers and Switch Settings	Game Structuring
Game Cost	Sw 5 off, Sw 6 on	2 plays per coin (one 2-player game or two 1-player games)
	Sw 5 on, Sw 6 off	1 coin per play
	Sw 5 on, Sw 6 on	2 coins per play
	Sw 5 off, Sw 6 off	Free play (no coins required)
Number of Heats	Sw 3 off, Sw 4 off	Three heats per play sequence
	Sw 3 on, Sw 4 off Sw 3 off, Sw 4 on	Four heats per play sequence
	Sw 3 on, Sw 4 on	Five heats per play sequence
Bonus (Extended) Play	Sw 1 off, Sw 2 off	No extended play (regardless of score level)
	Sw 1 on, Sw 2 off	Extended play for achievement of 4.9 seconds elapsed time
	Sw 1 off, Sw 2 on	Extended play for achievement of 5.9 seconds elapsed time
	Sw 1 on, Sw 2 on	Extended play for achievement of 6.9 seconds elapsed time
Unused Switches	Sw 7, Sw 8	Spares (no game structuring performed)

In the Drag Race game all structuring is accomplished by selecting positions of various switches on a miniature switch assembly mounted on the game printed circuit board. To do this the board has to be removed from its metal enclosure and then the switch positions have to be adjusted by hand.

Before performing any adjustment, the game should be de-energized or not operating. Further, it is also recommended that the power cord be unplugged beforehand.

While being careful to avoid touching any parts of the body against the TV chassis components or other wiring connections inside the cabinet, find the metal enclosure that houses the game PCB. Then unplug the edge connector to the RF board on the front of the enclosure, carefully noting how the connector plugs in. (It must be reconnected *in exactly* the same way after the switch positions have been changed.) Next remove the screws holding the RF board onto the enclosure and unplug the RF board

from the game PCB. Now the game PCB has been freed so that it can be slid out of the enclosure far enough to allow access to the switches. Examine the surface of the board and identify the switch assembly shown in Figure 2.

Table 2 shows the structuring for all possible switch positions.

After the desired structuring has been set up, slide the game PCB back into its enclosure and plug the RF board back on to the game PCB. Replace the RF board on the front of the enclosure and secure it in place. Then replug the edge connector back onto the RF board, *making sure* that it is reconnected in the way originally found.

After performing these adjustments, close and lock the rear panel, and energize the game.

D. PERFORMING THE SELF-TEST

To begin the self-test, find the self-test switch located just inside the coin door. Make sure the

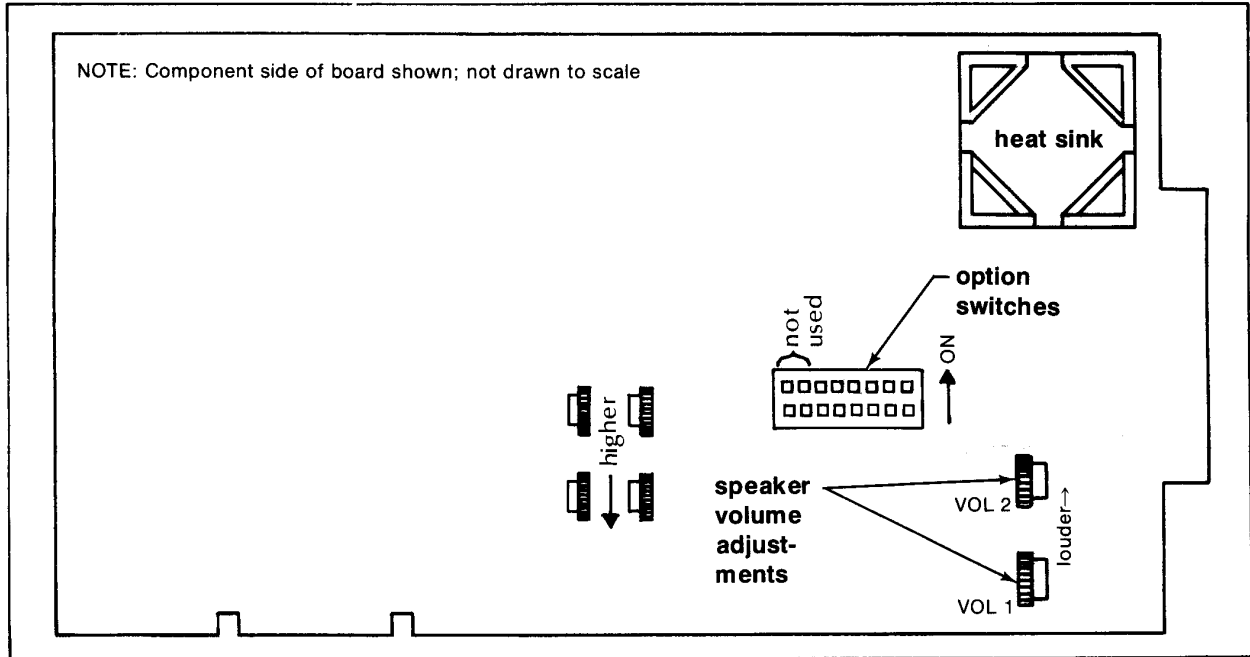

Figure 2 Approximate Locations of Option Switches and Sound Pitch, Tachometer and Volume Pots

game's power is on and that Drag Race is in the attract mode. Now push the self-test switch to its opposite position or *on*.

Immediately after pushing the self-test switch on, you should hear a series of eight *high* beeps. This is the first of three parts in the self-test procedure and checks that RAMs and program ROMs are working properly. If you hear one of the eight beeps as a *low* tone instead, refer to Table 3 to see which integrated circuit has failed. For example, if the sixth beep was low instead of high, then the I.C. at location A1 has failed.

Table 3 Locations of Memory Failures

Position of Low Tone in Eight-Beep Series of Self-Test	I.C. Location on PCB
1st	A0
2nd	C1
3rd	C1
4th	C1
5th	A1
6th	A1
7th	A1
8th	A1

Now press either start pushbutton to begin the second part of the self-test. This part tests the video generation circuitry, the motor sounds, and tachometer calibration. Immediately after pushing either start button, the test pattern shown in Figure 3 should appear on the video screen. You should visually verify that the pattern is correct. Note: Ignore any screen overlays in this photograph that might not agree with your Drag Race Game. Verify only the TV-screen images.

Also during this part of the self-test both motor sounds will turn on. Press all the way down on each gas pedal, and adjust the game for volume appropriate for your location. In addition, the gas pedals and tachometers will be activated. With no pressure on the gas pedals, the motor should idle between 200 and 1200 rpm. With your foot pressing the gas pedal all the way down, the motor should rev up to 9000–9500 rpm.

Now press either start button to begin the third self-test, which tests the functions of all switches. Activate each switch and you should hear a high beep; release that switch and you should hear a low beep. Both start pushbuttons and both coin mechanism trip wires can be checked by listening to

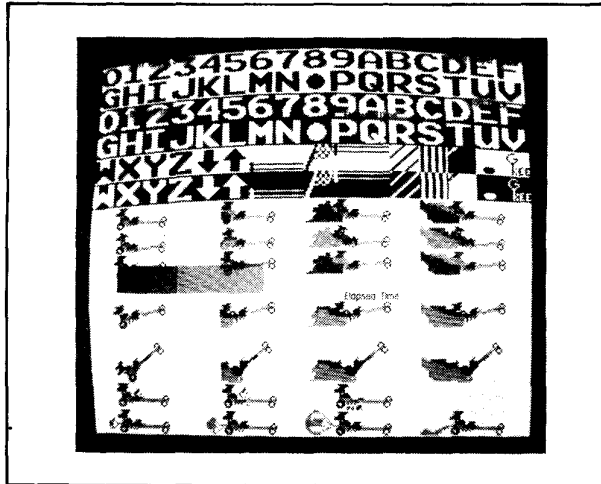

Figure 3 TV Screen Display During Self-Test

these tones. In addition, the start button lights will turn on when you press each button.

This ends the self-test procedure. Push the self-test switch back to its original position, so that Drag Race returns to the attract mode. Close and lock the coin door. If you wish to start the test procedure again, simply push the self-test switch to *on* again.

NOTE

Since some protective circuitry is bypassed in the test mode, it is possible for Drag Race to be "hung up" by an occasional static discharge or a line transient. If this occurs, simply push the self-test switch to off, then on again. This will restart the test sequence.



GAME PLAY

A. GENERAL GAME SEQUENCE

The player's objective is to drive a dragster to the finish line ahead of an opponent dragster. Elapsed times for the players are continuously displayed on the TV screen during play, as are each player's best elapsed time for that game.

A play sequence consists of a number of successive race heats in which two dragsters compete against one another by moving horizontally across the screen, from left to right. In a two-player game each player drives a separate dragster. In a one-player game the player drives one dragster and the game's internal circuitry "drives" the other dragster. However, as the elapsed time of the player's dragster improves, so also does that of the game's dragster.

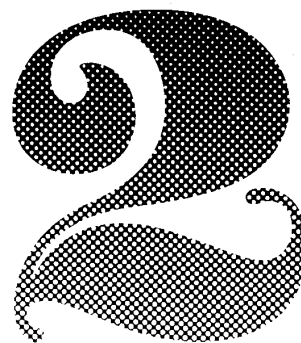

Before a race heat begins both dragsters are standing at the start line and the pickets in the fences beside each lane on the drag strip are motionless. Also, a "Christmas tree" color display portion of the TV screen, between the two dragsters, will display start timing. This display changing to green is the signal for the race to begin. If a player now puts the car in gear and steps all the way down on the gas pedal the dragster will move forward. Also the pickets in the fences begin to move, at a rate faster than that of the cars, thereby adding to the player's visual illusion of dragster speed and movement down the drag strip. A player may step down on the gas pedal while the Christmas tree is still yellow, but only if the car is in neutral. Otherwise, a red light appears, the words *TOO SOON* appear in that track, and that set of controls is disabled—holding the car back for about a second. Note that the car must be in gear to move. A player might thus have the car *in gear* before the green light appears, if the gas pedal is *not* depressed. Conversely, a more advanced player *can* depress the gas pedal before the green light appears, *if in neutral*. This will allow the engine to rev up before the green. Revving up in neutral requires some skill, as the revs climb quickly and the engine may blow when standing in neutral.

As the dragster moves forward, the player must listen to the pitch of the dragster's engine sounds and/or note the position of the tachometer needle, so that he or she will know when to shift into the next higher gear. If a player shifts too soon, the dragster's acceleration will drop off temporarily, lengthening the elapsed time for that heat. If a player fails to let off the gas during a shift and/or lets engine rpm's get a little too high before shifting, then the dragster may go into a "wheelie" (front wheels lift up off the ground) after the shift is completed. When this happens the dragster loses some acceleration for a few moments. If the player waits until the engine rpm is so high that the tachometer needle is in its red region, then the engine may blow up. When this happens an engine explosion picture appears on the TV screen, explosion sounds are heard, the message *ENGINE BLOWN* is displayed, the dragster's speed is brought to zero, and its controls are disabled for approximately one second. The player need not let off the gas pedal during a shift, but since the engine revs up very quickly in neutral, it is safer to do so.

During a race, a player must also manipulate the steering wheel so that the dragster remains in its lane along the drag strip. If a player allows the dragster to touch against the fence on either side of the lane,

then the dragster will be slowed down until the car is brought back away from the fence.

During a race heat, four numerical displays appear on the TV screen. One display above each track shows each player's current elapsed time. Two displays at the very top of the screen show the best elapsed time of each player during a given game. The numbers in the displays change as the dragsters move across the TV screen.

In addition to separate engine sounds for each dragster, the following other sounds can be produced during a race heat: two tones during the Christmas-tree starting sequence, a screech sound whenever the dragster touches against a fence, an explosion sound when an engine blows up, and a "whoosh" sound as the chute opens.

B. OPERATING MODES

The Drag Race game can be described as operating in three modes, attract, play or self-test. Plugging the power cord into an active AC outlet energizes the game and it starts out in the attract mode. The game remains in the attract mode until a player deposits a coin and presses a start button, causing the game to go into the play mode. The game remains in the play mode until the last race heat has ended, at which point the game reverts back to the attract mode.

NOTE

Sometimes upon initial application of power (or, more rarely, later on during play) the TV monitor may produce a "scrambled picture." This irregularity happens if the game's internal circuitry has not initialized itself. Although normally taken care of automatically, it is possible that severe noise spikes on the AC power line could upset the self-initialization. Generally a "scrambled picture" can be corrected by de-energizing the game and re-energizing it, one or more times. Do this either by unplugging the power plug from the wall outlet and reconnecting it, or else by opening and closing the cabinet's rear panel so that the interlock safety switch is exercised.

Attract Mode:

The bottom car repeatedly runs through a race sequence, while the top car is kept in a stationary position at the far left of the picture. In the top track instruction messages are written. Each message con-

sists of two lines, and there are three different messages. Each message shows for approximately 3½ seconds, in sequence. The instruction messages are:

OVER REVS BLOW ENGINE
2 PLAYS PER COIN, 1 COIN PER PLAY, or 2 COINS PER PLAY*

___ HEATS PER GAME (depending on switch settings)

BEAT _ _ _ _ FOR BONUS HEAT (depending on switch settings)**

No sounds are produced during the attract mode, all player controls are kept disabled, and players scores remain unchanged.

When the player has deposited the required number of coins (as defined by the operator option switches), the start pushbuttons will flash and the message CREDIT FOR ONE PLAYER (or CREDIT FOR 2 PLAYS, if appropriate) will replace the instructions in the top track. When either start button is pressed, that button will light steadily, the message WAIT FOR GREEN LIGHT will appear in both tracks, both DRIVER BEST TIME scores will disappear, the bottom dragster will reset to the far left, and motor sounds will be produced.

Play Mode:

If Drag Race has been set up for 1 coin per play (probably the most common coin setting) and only one coin has been deposited, then the player must choose to push one of the flashing start buttons. The unused start button will go dark. However, if two coins have been deposited, then this second start button will continue to flash: if pressed, it will remain lit and the other player's car controls will also be activated. If not pressed within five seconds after the first button was pressed, the second start button will go dark for the remainder of the game, and the second car controls will be disabled. However, credit will be saved for use in the next game. No sounds are produced yet.

NOTE

Throughout this manual and the Drag Race game, *play* as used in the coin messages is defined as either one 2-player game or two 1-player games.

For the next five seconds the elapsed time displays continue to show, two WAIT FOR GREEN LIGHT messages appear, then these displays are zeroed. The WAIT FOR GREEN LIGHT messages disappear from the tracks, and play begins with the Christmas-tree sequence (see Figure 4).

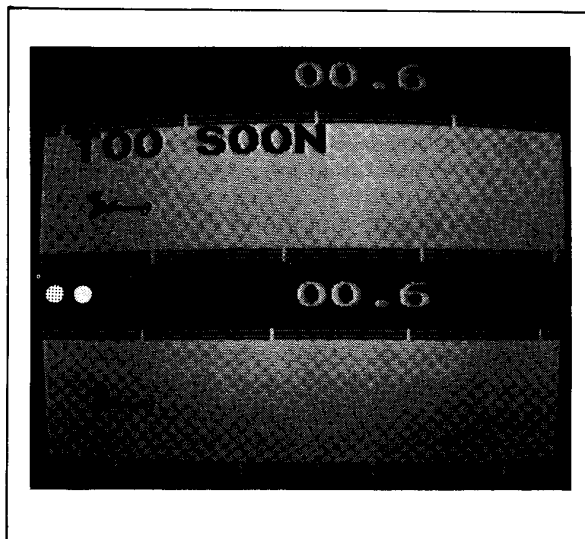

Figure 4 Typical TV Picture at Start of Race Heat (Shows Premature Start)

The players must now watch the Christmas tree display but should not start moving until the display color changes from yellow to green. If a player starts before this happens, the Christmas-tree display adds a red light, and the words *TOO SOON* appear in the track of the dragster that has started off too soon. As a player's penalty for doing this, the game returns that

*If the game is set for free play, this message will be replaced with CREDIT FOR 2 PLAYS.

**This message is displayed only if one of the three extended-play options has been chosen by the operator.

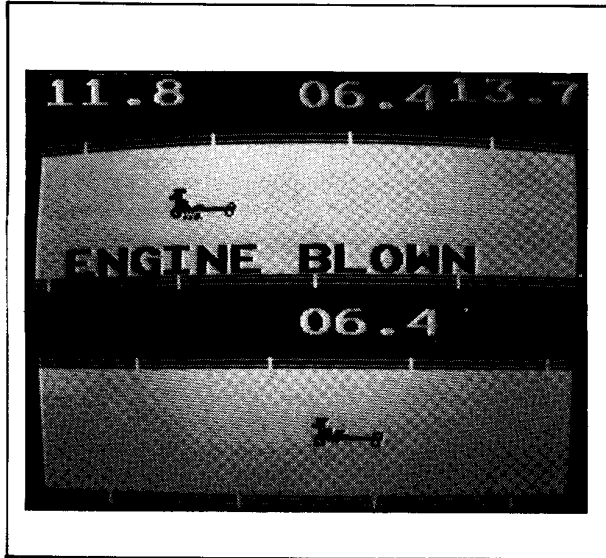

Figure 5 Typical TV Picture During Play

dragster to the starting line and disables it for approximately one second. The other dragster is allowed to continue the race, however. Three special types of sounds are produced only during the Christmas-tree sequence. A higher pitched "tick" tone is heard while the yellow color is blinking, a lower pitch "blap" tone when a red light is added, and a "beep" (mixture of both tones) when the green color appears.

In a one-player game, the dragster not driven by the player is under automatic computer control. It finishes in about 8.1 "seconds," as displayed under ELAPSED TIME (actually 16.2 seconds), until such time that the player beats it. Then the automatic car "improves" to finish heats in 6.4 "seconds"—adding incentive for players to try harder.

The race now continues as described previously under A. *General Game Sequence*. If a dragster's engine blows up, its speed drops to zero, the message *ENGINE BLOWN* appears, the player controls are disabled for one second, and then the dragster can move again. See Figure 5.

The numbers showing in the display for elapsed time change as the cars advance across the TV screen toward the right-hand side. When the dragster in front reaches the finish, the displays for that dragster freeze, that is, the numerals no longer change. Also, that player's "parachute" is automatically opened, bringing it to a stop. Figure 6 shows a typical picture at the end of a heat.

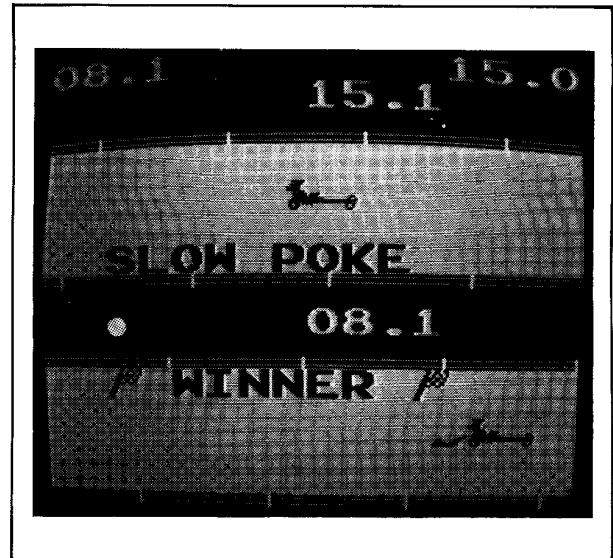
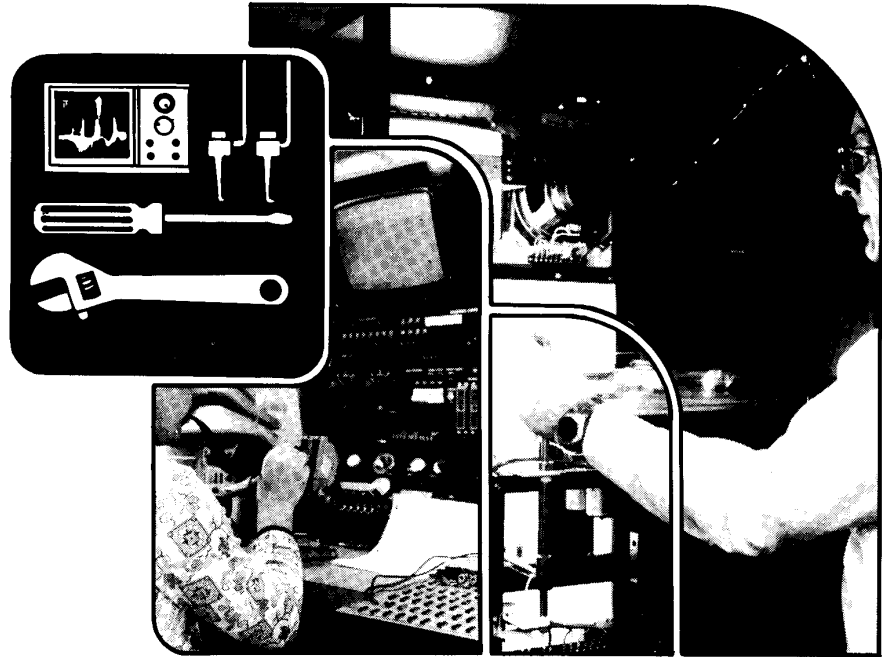

Figure 6 Typical TV Picture at End of Race Heat

If a dragster has not finished in 15 "seconds" (30 real seconds), those controls are disabled and the message *SLOW POKE* appears in that player's track. When either both cars have reached the end or the game has timed out in 30 real seconds, whichever comes first, both elapsed times are compared. The message *WINNER* bracketed by checkered flags then appears in the track of the car with the lower elapsed time. In case of a tie no such message appears. The scores under each BEST TIME are also changed now, if the new elapsed time is better than that of the previous heat.

If one or more heats still remain in the play sequence, after a few seconds the game's control circuitry brings both dragsters back to the starting line, and a new heat can be run. After the last regular heat is finished (3, 4, or 5 heats, depending on the option switch setting), the scores under BEST TIME are compared to the bonus level set by the operator. If either player has beaten the bonus level time, the message *BONUS HEAT* appears in both tracks. After a few more seconds, an additional heat is started. Note: the automatically controlled dragster in a one-player game cannot cause a bonus heat—only *players'* scores are compared to the bonus level.

If no heats remain in the play sequence, then the game reverts back to the attract mode and the player scores remain displayed as they were.



MAINTENANCE AND ADJUSTMENTS

Due to its solid-state electronic circuitry, this Kee Games unit should require very little maintenance and only occasional adjustment. Information given in this chapter and elsewhere in the manual is intended to cover most servicing situations that may be encountered at the game site. The procedures given are in sufficient detail to be understood by a person with moderate technical ability.

NOTE

If reading through the manual does not lead to solving the specific maintenance problem, you can reach Atari's Customer Service Department by telephone (open Monday through Friday, 7:30 am to 4:30 pm Pacific Standard Time):

*from outside California (800) 538-6892
(toll-free)*

from inside California (408) 984-1900

*For those interested in gaining more information on video game technology, especially the electronics, we recommend reading the **Video Game Operator's Handbook**, manual no. TM-043. This book is available from Atari, Inc., attn. Customer Service Dept., 2175 Martin Avenue, Santa Clara, CA 95050 for \$5.00 each, or from your distributor.*

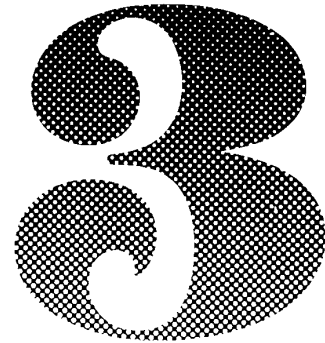

A. CLEANING

The exteriors of the game cabinets and plex panels may be cleaned with any non-abrasive household cleaner. If desired, special coin machine cleaners that leave no residue can be obtained from distributors. Do *not* dry-wipe the plex panels because any dust on the surface can scratch the surface and fog the plastic.

B. ADJUSTMENTS ON TV MONITOR

NOTE

The TV monitor is accessible only from inside the game cabinet and these adjustments have to be done while the game is energized. Therefore only persons familiar with safety measures and repair procedures on electrical equipment should perform them.

The TV monitor need be adjusted *only* when the picture is distorted, or if the contrast or brightness seem out of adjustment.

The monitor's adjustments function like those of a conventional commercial television set, except that the volume adjustment has no effect. Instead the game produces its sound in speakers separate from the TV monitor. Figure 7 shows the location of the adjustment on the rear of the chassis. When making the adjustments follow these general guidelines:

BRITE (Brightness)—Perform this adjustment before the contrast. Adjust so that the white lines covering the screen just barely disappear, when the brightness is turned up.

CONT (Contrast)—Adjust so that the images are as bright as possible against the dark background without being blurred.

HORIZ HOLD (Horizontal Hold)—Adjust if the picture is slightly off-center horizontally, if the images appear warped, or if the picture is broken up into a series of diagonal lines. Adjust for a stable, centered picture.

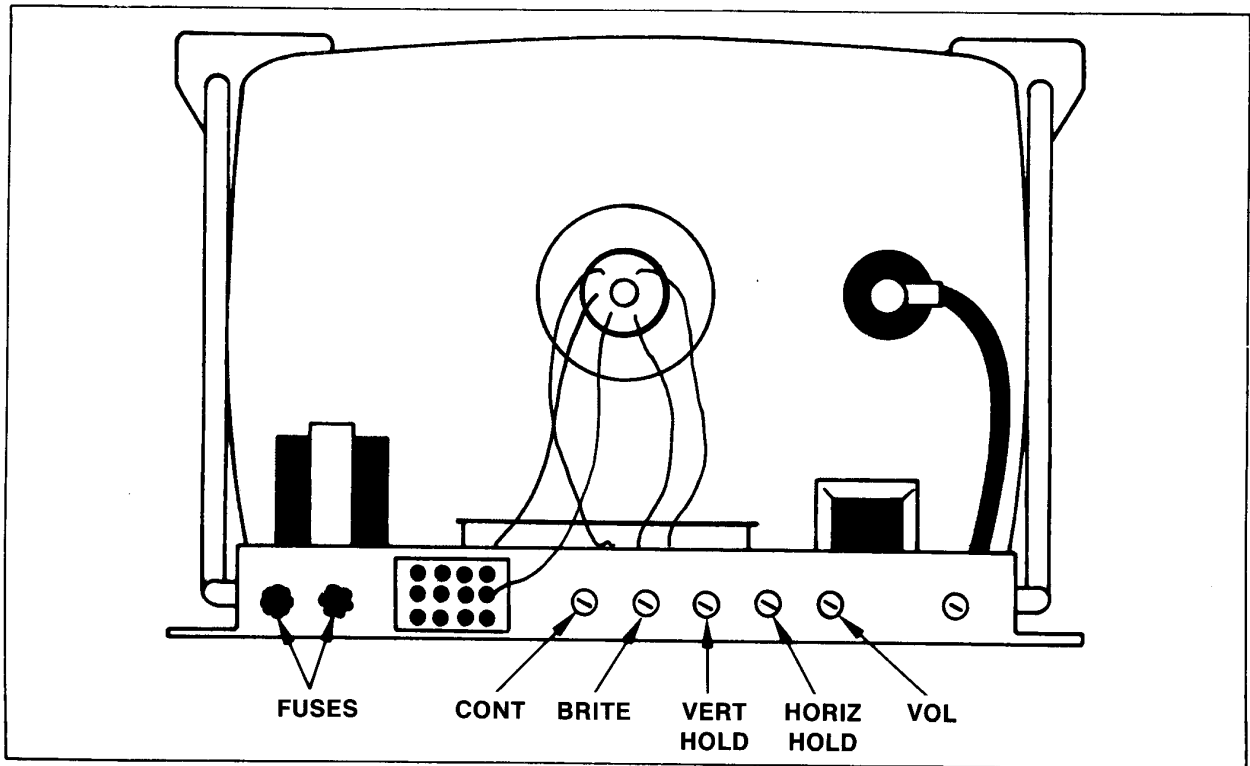

Figure 7 Locations of Adjustments on TV Chassis

VERT HOLD (Vertical Hold)—This needs adjustment only if the picture appears to be rolling up or down the screen. Adjust for a stable, centered picture.

C. ADJUSTMENT OF BOTH SPEAKER VOLUMES

The speaker electronic drive circuit is provided with two potentiometers that control the volume of sounds produced during play. These potentiometers are mounted on a printed circuit board inside the game cabinet and can be manually adjusted separately for each speaker to give the volume level desired. The following procedure tells how to make the adjustments.

Unlock and remove the access panel at the rear of the cabinet. Doing this should cause the interlock switch to de-energize the game.

While being careful to avoid touching any parts of the body against the TV chassis components or other wiring connections inside the cabinet, find the metal enclosure that houses the game PCB. Unplug the edge connector that connects the wire harness to the RF board mounted on the front of the metal enclosure. Note how this connector plugs in; it must be reconnected in *exactly* the same way after the volume adjustment has been made. Next remove the screws that hold the RF board onto the front of the metal enclosure, and then unplug the RF board from the game PCB. The game PCB is now free to move out of the enclosure.

Slide the PCB on its guides until it is partway out and the volume adjustment potentiometers are accessible. Figure 2 shows their approximate locations. To *increase* speaker volume, move the stud on top of each potentiometer body in the direction shown by the arrow in Figure 2. To *decrease* speaker volume, move the stud in the opposite direction.

After making adjustments, push the game PCB all the way back into the enclosure, replug the RF board onto the game PCB, and then secure it in place on the front of the enclosure. Next replug the wire harness edge connector back onto the RF board, *making sure* that it is reconnected in the way originally found. Then replace the cabinet panel and energize the game.

D. ADJUSTMENT OF BOTH SOUND PITCHES AND TACHOMETERS

The motor sound circuitry includes two potentiometers (one per player) that control the pitch of sounds produced and two other pots to calibrate the readings of each tachometer. These can be adjusted as follows.

Place the game in the test mode by pushing the self-test switch to *on*. (The self-test switch is located just inside the coin door.) Wait for the series of eight high beeps, then press one of the start buttons.

Using Figure 2, find the two pots labeled *SP1* and *SP2* on your printed circuit board. Press all the way down on each gas pedal and adjust each of these pots for pleasing high rpm sound. *SP1* controls the sound pitch produced out of the *right* speaker; *SP2* controls that of the *left* speaker.

Next find the pots labeled *T1* and *T2*. Again press all the way down on each gas pedal and adjust these pots so that both tachometers read 9500 rpm. *T1* controls the right tachometer's calibration, *T2* the left tachometer. Release both gas pedals, and make sure that both tachometers read 200–1200 rpm while the game is idling.

Return the self-test switch to the *off* position; then push the game PCB back into the steel enclosure. Plug the RF board onto the game PCB, then secure the RF board on the front of the enclosure. Replug the wire harness edge connector back onto the RF board *exactly* the same way as when removed. Finally, close the cabinet panel and energize the game.

E. ADJUSTMENT FOR GAME PLAY WITH ONE SET OF CONTROLS:

As a temporary measure until repairs can be made, the game can still be used even if one set of player controls is not working. In this situation only one-player games are possible.

To disable either set of controls, the corresponding start button and lamp are simply disconnected. To do this, remove the dashboard assembly by undoing the four carriage bolts holding down the dashboard. Remove the one wire from the switch and the two wires from the lamps. Carefully wrap the exposed end of each wire with electrical tape to keep it from touching the other wires or from touching anything else inside the game. At a later time when repairs have been made, you can reconnect these wires—

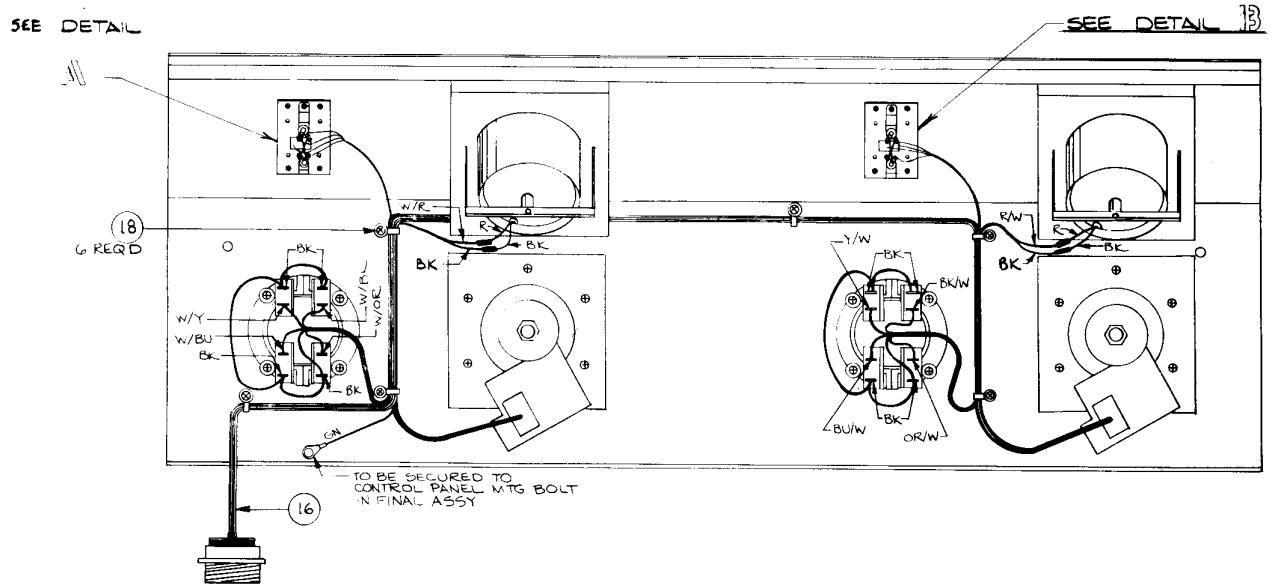
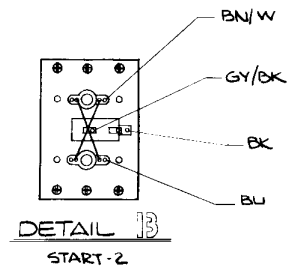
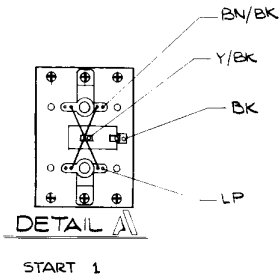

Item	Part Number	Qty.	Description
1	008772-01	1	Alum., Control Panel W/Graphics
2	005386-01	1	Board, Panel
3	000598-02	2	Steering Wheel, Assy. (10" Dia Wheel)
4	72-1112S	20	Screw, Mach., Pan HD., Phil., #10-24 x 3/4Lg.
5	000567	2	Bow Washer
6	A000608-01	2	H - Shift Assembly
7	005255-02	1	Shift Bezel
8	75-552 On	4	Carriage Bolts # $\frac{1}{4}$ -20 x 1.25" Lg.
9	75-015S	4	Washer, Flat $\frac{1}{4}$ -20
10	75-045	4	Washer, Split Lock, $\frac{1}{4}$ -20
11	75-915S	4	Nut, Mach., Hex, $\frac{1}{4}$ -20
12	A005417-01	1	Top Control Panel - Tach.Assembly
13	005418-01	2	Tachometers
14	005412-01	2	Plex Covers - Tach.
15	78-6A00401	A/R	Tape, Self Adhesive, Two-Side Vinyl Foam
16	A006185-01	1	Control Panel Harness
17	75-010S	8	#10 Flat Washer
18	72-6610	6	Screw, Sm., Pan. HD., Phil., #6-5/8 Lg.
19	A007357-01	2	Start Button Assembly
20			

Figure 8 Dashboard Assembly

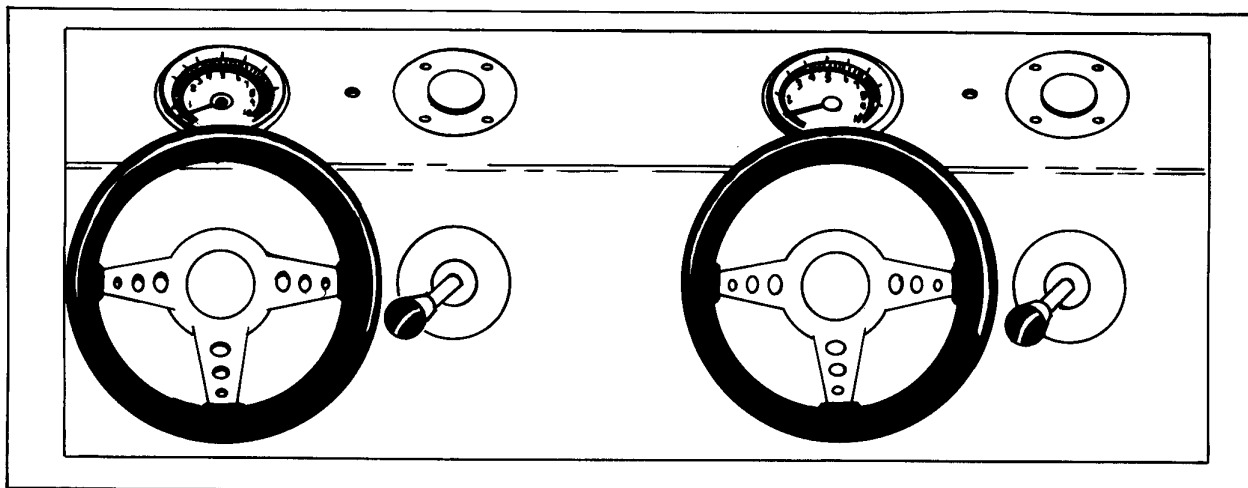

Figure 8 Dashboard Assembly

making sure the wires are re-connected as per the illustration (Figure 8).

CAUTION

You may damage the Drag Race printed circuit board if you reverse the connections to the start pushbutton when re-assembling its wiring.

Also shown in the photograph is a slam switch assembly. It has been included to defeat any players who might try to obtain free game plays by violently pounding on the coin door to momentarily close the contacts on the coin switch. The slam switch contacts connect to the microcomputer system, which will ignore coin switch signals whenever the slam switch contacts are closed.

F. COIN MECHANISM ADJUSTMENTS

Components On Coin Door

Figure 9 shows the back side of the coin door assembly where the game's two coin mechanisms are mounted. Included is the lock-out coil assembly; the lock-out wires are connected to this assembly but are hidden behind the coin mechs. During the attract mode the microcomputer energizes the lock-out coil, causing the lock-out wires to retract far enough to allow genuine coins to reach the coin box. But during the ready-to-play mode when the LED is lighted and during the play mode (and also when AC power to the game has been turned off) the lock-out coil is de-energized, causing the lockout wires to move out far enough to divert coins over to the return chute.

Directly below each coin mechanism is a secondary coin chute and a coin switch with a trip wire extending out to the front edge of the chute. When the trip wire is positioned correctly, a coin passing down the secondary chute and into the coin box will momentarily push the trip wire down and cause the switch contacts to close.

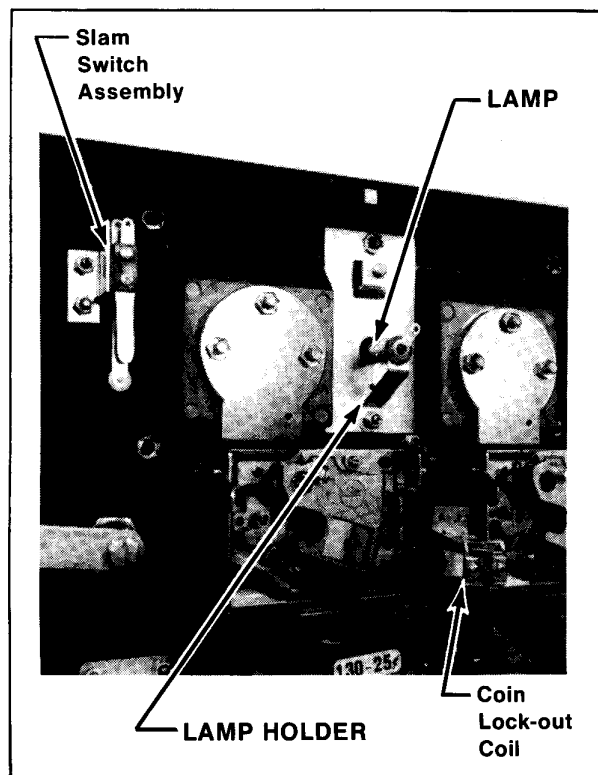

Figure 9 Coin Door Assembly

Access To Coin Mechanisms

To remove jammed coins, and for maintenance cleaning, each magnet gate assembly can be hinged open without removing it from the door, as shown in Figure 10. Or, if necessary, each coin mechanism can



Figure 10 Hinging Open the Magnet Gate Assembly

be entirely removed from the door merely by pulling back on a release lever and simultaneously tilting the mechanism back, then lifting it up and out. This is shown in Figure 11.

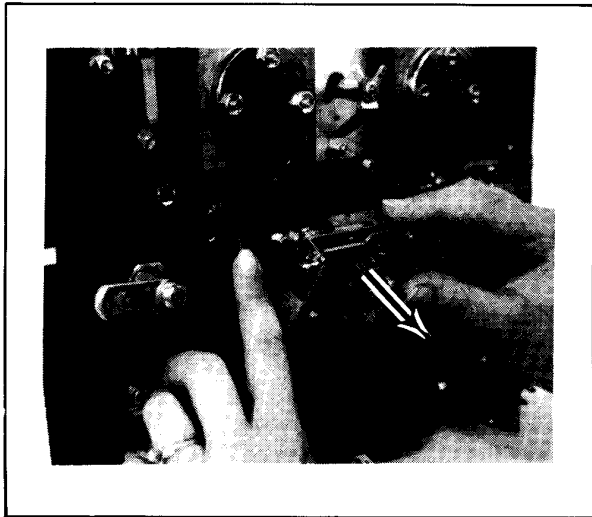

Figure 11 Removal of Coin Mechanism

Cleaning of Coin Paths

CAUTION

The use of an abrasive (such as steel wool or a wire brush) or a lubrication on a coin mechanism will result in a rapid buildup of residue.

By talking to many operators, we have found that the best method of cleaning a coin mechanism is by using hot or boiling water and a mild detergent. A toothbrush may be used for those stubborn buildups of residue. After cleaning, flush thoroughly with hot or boiling water, then blow out all water with compressed air.

Figure 12 shows the surfaces to clean inside the coin mechanism. These include the inside surface of the mainplate, and the corresponding surface of the gate assembly. There may also be metal particles clinging to the magnet itself. To remove these you can guide the point of a screwdriver or similar tool along the edge of the magnet.

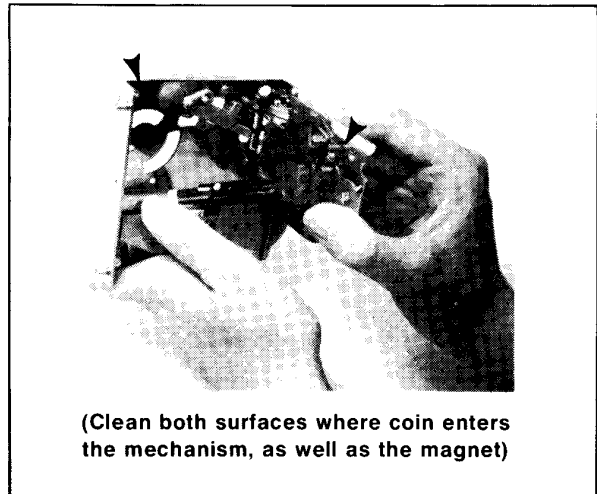

Figure 12 Surfaces to Clean Inside the Coin Mechanism

If coins are not traveling as far as the coin mechanisms, you will need to clean the channel beneath the coin slot. To gain access to this channel, use a $\frac{3}{8}$ -inch wrench and remove all three nuts that secure the cover plate (refer to Figure 13). Removing the plate will provide access to the entire channel.

Also clean the inside surfaces of the secondary coin chutes, but when doing this be careful not to damage or bend the trip wires on the coin switches.

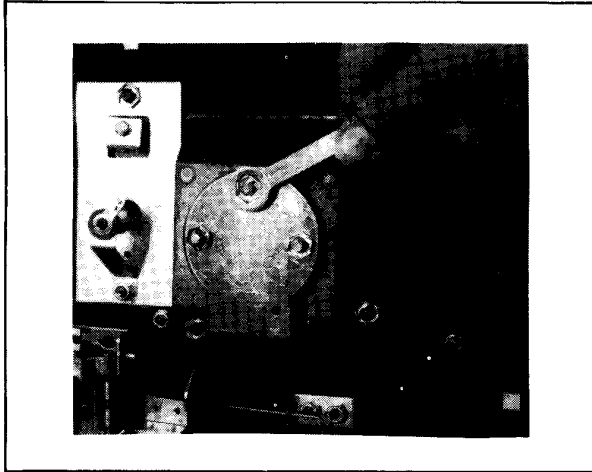

Figure 13 Removal of Plate Covering Rear of Coin Slot

Lubrication. Do *not* apply lubrication to the coin mechanisms. The only points that may need lubrication (and only rarely) are the shafts of the scavenger buttons (coin rejection buttons) where they pass through the coin door. Apply only one drop of light machine oil, and be positive that no oil drops down onto a coin mechanism. Figure 14 shows this lubrication point.

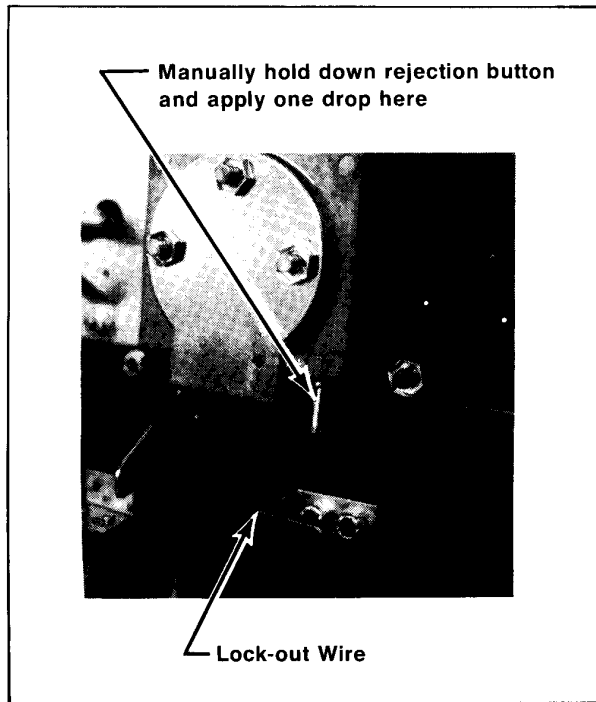

Figure 14 Close-up View of Lubrication Point

Adjustment of Coin Switch Trip Wire

In order for a coin switch to operate reliably when a coin travels down the secondary coin chute, the rest position of its trip wire should be as shown in Figure 15. Use extreme care when handling or touching these wires.

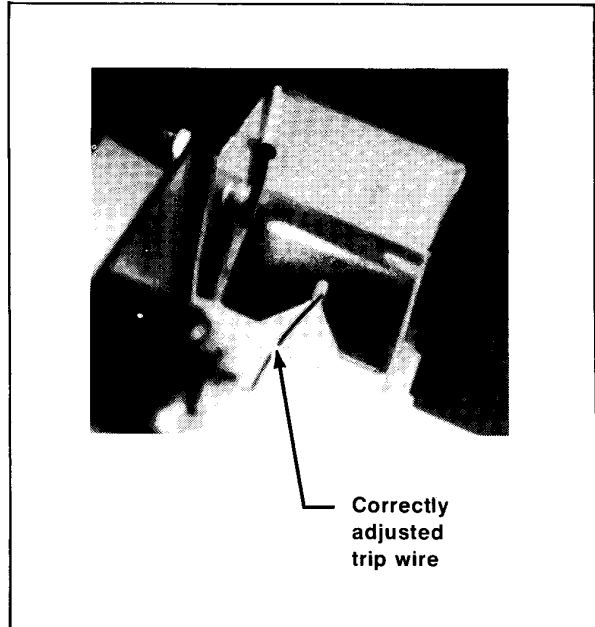

Figure 15 Detail View of Coin Switch and Trip Wire

Mechanical Adjustments on Coin Mechanism

Coin mechanisms are adjusted prior to shipment from the factory and normally will retain these adjustments for many months. If, due to wear or other causes, it becomes necessary to make new adjustments, remove the coin mechanism from the coin door. Then take it to a clean, well lighted area where it can be placed in a vertical position on a level surface (such as a bench top). Besides a screwdriver, you will need a set of several coins, including both new and old, worn ones. Figure 16 shows an exploded view of the mechanism and gives procedures for adjusting the kicker, separator, and the magnet gate. These adjustments should only be done by someone who has experience in servicing coin mechanisms and who understands their operation.

General Troubleshooting Hints

The first action is to look for jammed coins. After these have been removed, examine the coin path for presence of foreign material or loose objects (such as chewing gum, small metallic objects, paper wads, etc.). In cases where game usage is heavy, it may be

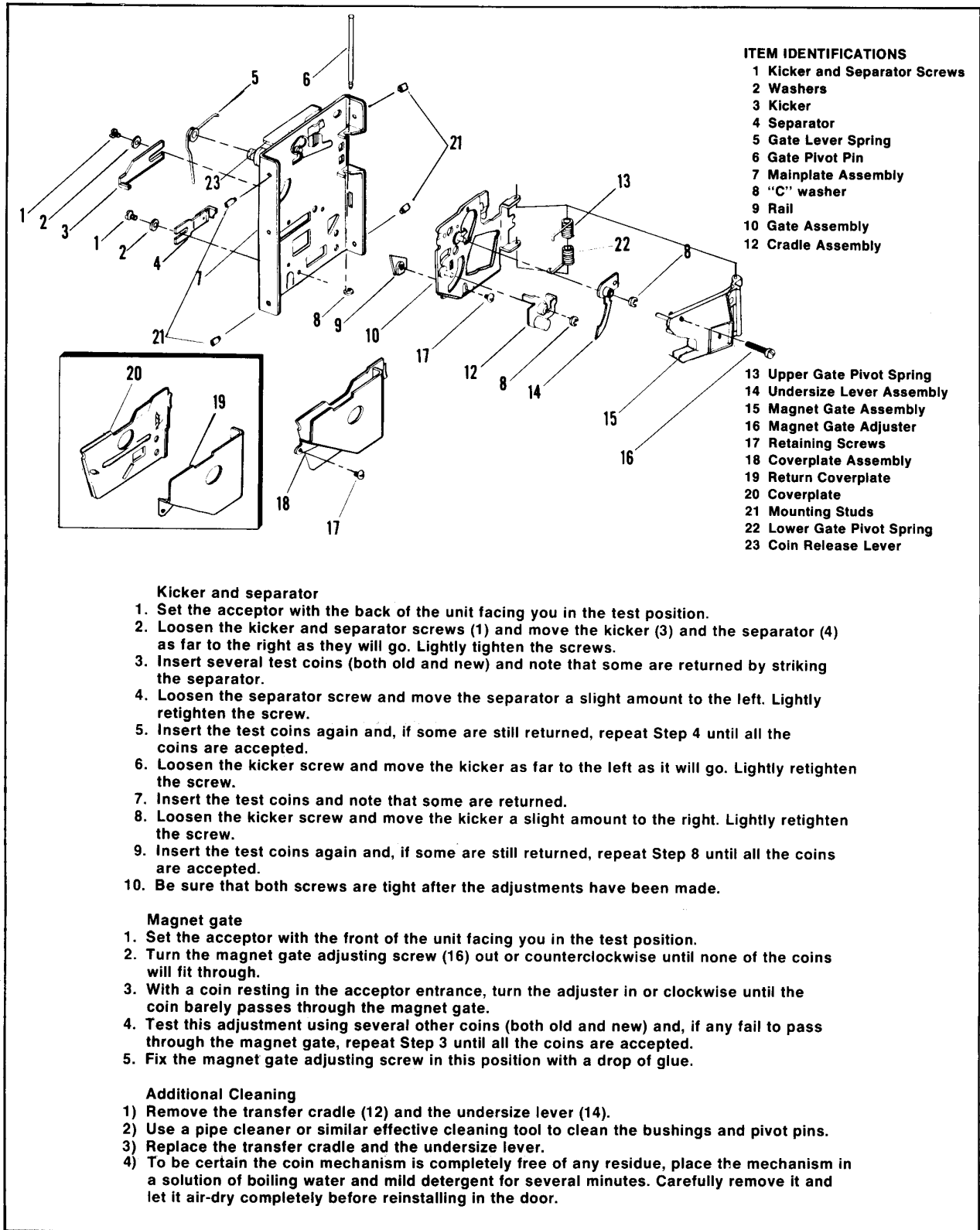
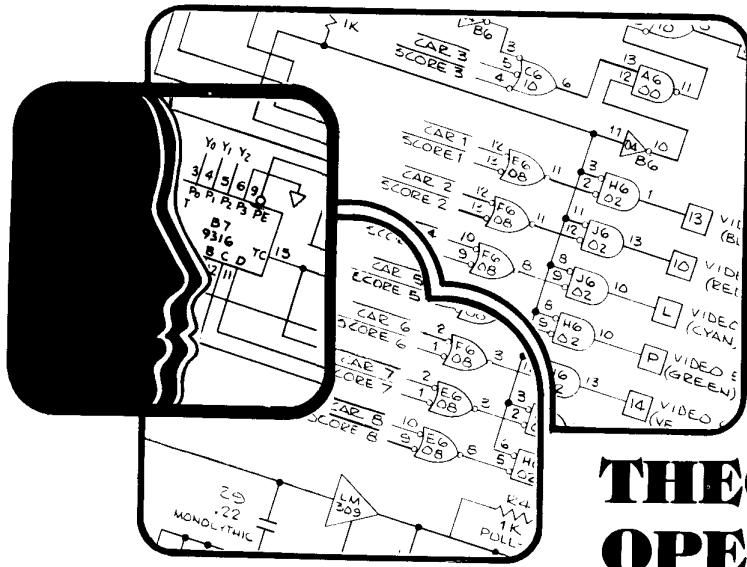

Figure 16 Adjustments on Coin Mechanism

necessary to clean the entire coin path periodically, in order to prevent build-up of contaminants that can hinder the movement of coins through the mechanisms. Also confirm that the trip wire on each coin switch is intact, and is properly adjusted. If troubles still persist, check the conditions and positions

of the lock-out wires, and the mechanical adjustments on the coin mechanisms, before suspecting the electronics. If a coin mechanism rejects genuine coins, try to readjust it. If this is not successful, then replace it with a working mechanism.



THEORY OF OPERATION

A. GENERAL INFORMATION

The block diagram in Figure 17 shows the major functional parts of the Drag Race™ game and their interconnections. Note that the game printed circuit board sends a composite video signal to the TV monitor and a separate audio signal to each speaker.

The general information about the Drag Race™ game given here provides a background for understanding certain parts of Chapters 1 and 2.

The game's TV monitor is a self-contained transistorized television monitor supplied to Atari by Motorola. Because the composite video signal sent to the monitor by the game control circuitry differs in certain important respects from the signal derived from commercial TV broadcasts, the picture appearing on the screen is unlike that of a home TV set and the monitor does not produce any sound.

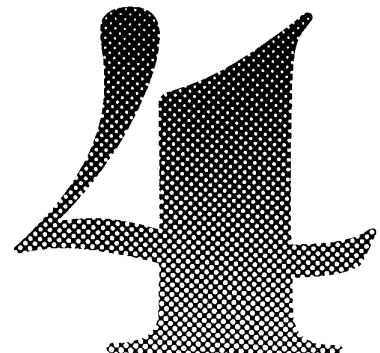

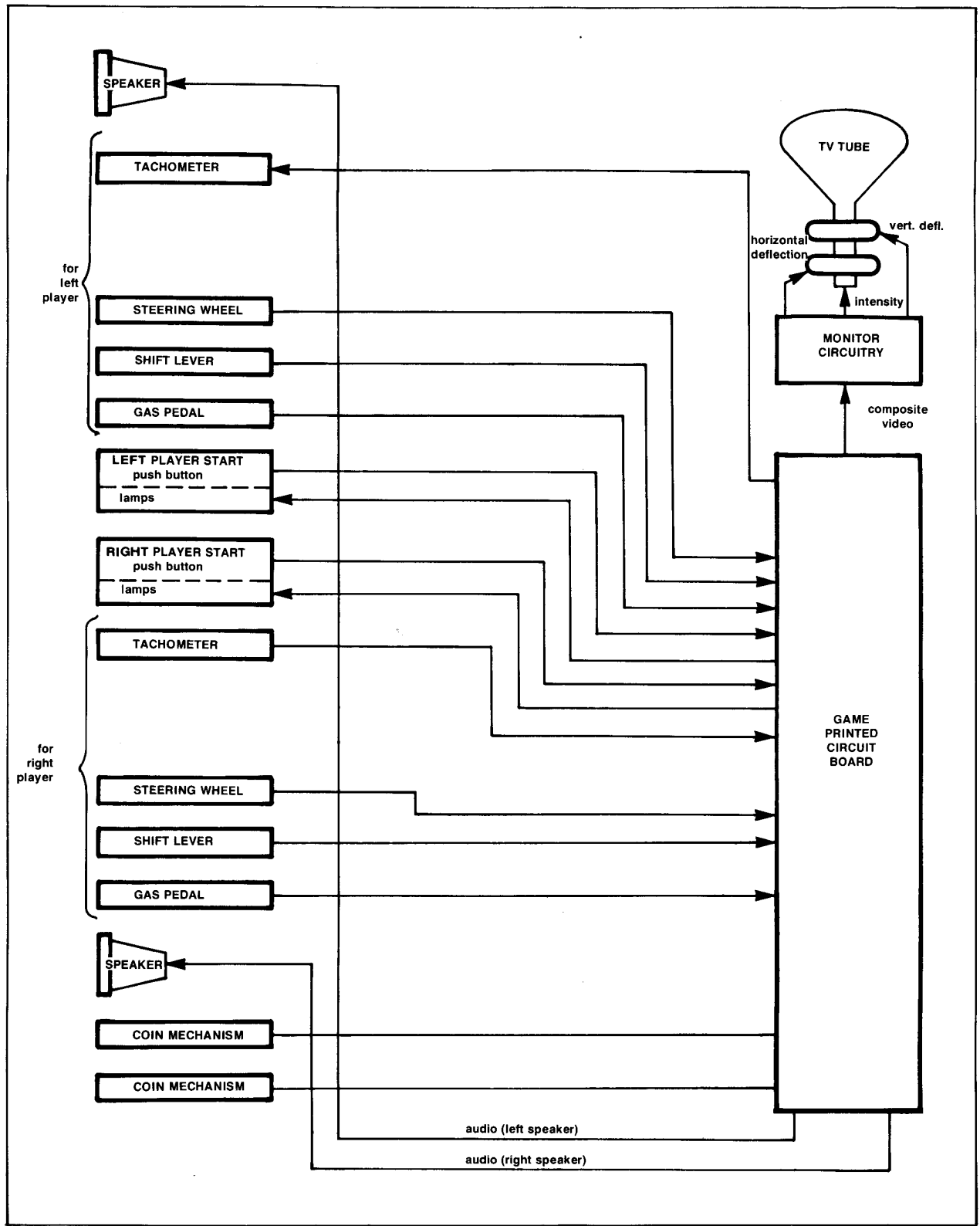

Figure 17 Functional Block Diagram of "Drag Race" Game

The game's composite video signal is constructed to produce only four video levels, instead of the more or less continuous shades of gray seen on a home TV screen. These four levels are named white, gray, charcoal and black.

This chapter of the manual gives technical descriptions of game circuitry regarded as field-repairable. Correction in the field of troubles traced to certain portions of the circuitry on the PCB may require replacement of the entire board.

The drawings included in this chapter supplement the text given here. Figure 20 is a seven-sheet schematic diagram of the circuitry on the printed circuit board. Figure 21 is the PCB assembly drawing and parts list showing the locations of the components called out on the schematic. The position of each integrated circuit device is identified by a column letter designation (A through R), and by a row number designation (0 through 9). Figure 22 is a harness schematic that shows the wiring connections between the PCB, player controls, and other components mounted inside the cabinet. A schematic diagram of the TV monitor's circuitry is also included as Figure 23.

NOTE

On the PCB schematic the symbol *P* (appearing at various inputs to logic gates and other integrated circuits) indicates a connection to +5 volts through a pull-up resistor.

B. SYNC AND POWER CIRCUITRY (SHEET 1 OF SCHEMATIC)

Clock Generator

The output from a 12-MHz crystal-controlled oscillator is inverted to produce the OCLK signal at R3 pin 8. This signal is divided down by a type-7474 flip-flop to produce the CLOCK signal at P4 pin 9. CLOCK drives the horizontal chain of countdown counters; OCLK and CLOCK are used for clock synchronization in other places on the board. In particular, OCLK is divided by 12 in the type-7492 counter (at R4) to produce the microprocessor clock.

Sync Countdown Chains

Flip-flop P4 and counters P5 and R5 form the horizontal countdown chain. They count down the frequency of the CLOCK signal to produce the 1H through 256H timing signals. Four of these signals are

applied to a dual flip-flop configuration to produce a signal at R6 pin 9 that drives the vertical countdown chain. Counters L7 and K7 form this counter chain and produce the 1V through 128V timing signals, and the V BLANK signal at M9 pin 9. Other decoding takes place in the ROM in L8, clocked by the type-74175 flip-flop in L9, to produce the V SYNC signal at L9 pin 15.

Power Supplies

The 5VAC taps from the power transformer connect to a full-wave diode rectifier circuit containing a type-LM323 amplifier. This power supply produces a +8V unregulated voltage and the +5V used as the V_{cc} supply on the board. The 15VAC taps from the transformer connect to another full-wave diode rectifier circuit that contains a type-7812 amplifier. This supply produces a +18V unregulated voltage and also a +12V regulated output.

C. MICROCOMPUTER SYSTEM (SHEET 2 OF SCHEMATIC)

The primary function of the Drag Race Microcomputer is to instruct the game circuitry for the proper TV monitor display and audio outputs for corresponding manual inputs.

The microcomputer system carries out complex tasks of the game by performing a large number of simple tasks. Control of the system is the primary function of the Microprocessor. The Microprocessor causes the system to perform the desired operations by addressing the Program PROMs (programmable read-only memories) for an instruction, reading that instruction, then executing the simple task dictated by that instruction. Temporary storage of data necessary for the execution of a future instruction, such as arithmetic operation, takes place in the Page Zero memory.

Microprocessor (center of schematic sheet 2):

As mentioned earlier, the controller of the Microcomputer is the Microprocessor. From the Microprocessor, a sixteen-bit address bus addresses the Program PROMs, Page Zero, and Enable. An eight-bit bi-directional data bus serves as a path for transferring data from the Program PROMs, to and from Page Zero, and to the position and playfield RAMs.

Microcomputer Watchdog

Watchdog is an external monitoring system that resets the Program execution back to its initial instructions, if the program execution deviates from its

intended sequence. This is accomplished by a watchdog statement (address code), incorporated in Program Memory (Program PROMs), that results in a $\overline{\text{WATCHDOG}}$ pulse at the reset inputs of counter J4. This clears the count of vertical blanking pulses (V BLANK) and must be accomplished before the counter reaches the count of seven vertical blanking pulses.

$\overline{\text{DIAG}}$ Signal

The $\overline{\text{DIAG}}$ signal, derived from A13, A14, and A15 (see address map on the schematic's Sheet 1) is used in conjunction with the diagnostic test fixture to disable a ROM and RAM on the game PCB. In normal game play it will be high, whenever a ROM or RAM is addressed.

$\overline{\text{HALT}}$ Signal

The video circuits need access to position memory every four lines during horizontal blanking. The $\overline{\text{HALT}}$ signal is used at this time to stop the processor and switch the type-9322 multiplexers M7 and M8. See the upper left of Sheet 4 on the schematic.

D. PROGRAM MEMORY (SHEET 3 OF SCHEMATIC)

Program PROMs

The Program PROMs consist of read-only memories (ROMs), permanently programmed by Atari to execute the Drag Race game. This memory has the capability of outputting eight bits of data for each of 4096 combinations of ones and zeros on the 12 address inputs. In computer terminology, this is stated as a memory size of 4K x 8.

The Drag Race game's Program PROMs consist of two chips. Since data in the Program PROMs is a permanent physical configuration of the PROM chips, the data is not lost when power is disconnected from the game or when the chip is removed from its socket. Since the Program PROMs consist of read-only memories, the result of an address input can only be the "reading" of data stored in the manufacturing process. It is not possible to "write" in more data. (The term PROM stands for programmable read-only memory. To Atari, this means that the chip is a programmable ROM. To you, this chip is only a ROM.)

Program PROMs Enable

With initial power applied to the Drag Race PCB, the Microprocessor addresses the Program PROMs for an instruction by placing a sixteen-bit code at

outputs A0 through A15. Enable C0 receives four address lines (A9, A10, A11, and $\overline{\text{A12}}$) as an instruction of which part of the Program PROMs to access. Outputs of one-of-ten decoder C0 enable only the individual ROMs of the Program PROMs required for the desired instruction.

Page Zero Memory (right side of schematic sheet 3)

Page Zero memory consists of random-access memory (RAM). Data may be stored in Page Zero memory (called "writing" Page Zero), then later recalled (called "reading" Page Zero). Memory size of Page Zero is 128 x 8.

In order to read Page Zero, R/W (pin 16) input of the chips must be a high logic level and the chip must be selected (pins 10–15 high). To write Page Zero, R/W input must be a low logic level and the chip must also be selected.

As previously mentioned, data stored in Page Zero memory is for the purpose of performing operations on data as instructed by the Program PROMs. Since Page Zero is a temporary storage area, removing power from the chips will "erase" all stored data.

Page Zero Enable

Now, with Enable addressed for the enabling of the desired Program PROMs, and the Program PROMs addressed for a data instruction, the Microprocessor receives an eight-bit data instruction from the Program PROMs on the data bus. If this data instruction includes the storage of information, the Microprocessor writes data into Page Zero. The procedure of writing into Page Zero is enabled by six signals: A7 and $\overline{\text{DIAG}}$ must be high, and A10, A11, A12 plus read/write $\overline{\text{R/W}}$ (pin 16) must be low. With this condition, data from the Microprocessor on the data bus is stored into a Page Zero location determined by Page Zero address inputs A0 through A7.

E. MEMORY CIRCUITRY (SHEET 4 OF SCHEMATIC)

Position Memory (left half of page)

The RAM device in location N7 serves as a position memory for four-line strips of the TV picture. Each four-line strip can be moved either horizontally or vertically on the TV screen. The $\overline{\text{POSEN}}$ (position enable) signal provides the command for writing data into this particular memory. The RAM outputs are applied to type-74LS175 quad flip-flops, whose outputs then connect to the type-7483 adders in loca-

tions K5, L5, M5 and N5. New information is read for each four-line strip while $\overline{\text{HALT}}$ is low.

When input data to the adders are all zero, the adder outputs (the signals 1VXX, 2VXX, etc., and 1HXL, 2HXL, etc.) have the same timing as the 1V through 128V and 1H through 128H signals produced by the countdown chains (see next subsection). But when input data to the adders are non-zero, then the four-line strips in the TV picture will be offset.

Playfield Memory (right half of the page)

The type-9322 data selector devices in locations K4 and L4 operate on the adder outputs to produce data for the RAM devices in K3 and L3. These RAMs serve as the playfield memory and their outputs are used to address object memory ROMs. All objects that can appear in the TV picture, including alphanumeric characters, have been pre-programmed in the object memory ROMs.

Tri-State Devices

Tri-state devices, such as H2 of schematic sheet 4, are capable of having normal logic output of ones and zeros when disable (pin 1) is at a low logic level. When disable is at a high logic level, the output becomes a high impedance. In other words, when disable is at a high logic level, it is equivalent to completely removing device H2 from the circuit. ROMs and RAMs are also tri-state devices. Each ROM or RAM must be enabled by certain logic levels at its chip-enable inputs before the device is capable of inputting or outputting data. In the case of the Page Zero RAM, these chip-enable inputs are identified as CS0–CS5.

F. VIDEO CIRCUITRY (SHEET 5 OF SCHEMATIC)

Object Memory

The type-82S115 ROM devices form the object memory in which objects that can appear in the TV picture have been pre-programmed. The DATA 0 through DATA 7 signals determine which picture is being addressed. The 1VXX through 8VXX and 8HXL signals determine the line-by-line sequencing of the object data to be read out from memory.

Video Serializing

The type-74165 shift register devices in locations M3 and M2 accept data in parallel from the ROMs and produce serial outputs (at pin 13). The type-74151 data selector devices in P2 and R2 determine what picture information will be sent on to the video summing

circuit. The type-74LS175 device in location N2 performs a clocking function. Its three output signals are used to address data selectors P2 and R2, so that part of their determination of picture information will involve selecting supergraphics or not, depending on the states of the DATA 5, DATA 6 and DATA 7 signals.

Video Summing

The junction of resistors R87 through R91 forms the video summing point. The resistors have different values; they are weighted to construct the four different video levels (white, gray, charcoal and black). Resistor R90 couples the synchronization information, and R88 and R89 couple the picture information. The composite video signal is coupled through R90 and passes on to the TV monitor through the wiring harness.

G. INPUT/OUTPUT CIRCUITRY (SHEET 6 OF SCHEMATIC)

Switch Sensing (right half of page)

The purpose of the switch sensing circuit is to sense the positions of the following switches: the six switches on SW1 (the operator miniature switch assembly mounted on the printed circuit board), the two coin mechanism switches, the self-test switch, and switches on the player controls (accelerator pedals, shift levers, and start push buttons). A different circuit is used for sensing of steering wheel movement (see page 51). The switch sensing circuit produces only one output—the DBUS7 signal in Zone D2.

Terminals from each of the two coin mechanism switches connect through the wiring harness and edge connector pins 16 and S to selector 9. Other inputs to this selector come from selectors H9 and J9. When a coin passes through a coin mechanism, the normally-open contacts of that coin switch momentarily close. This causes the electromechanical coin counter's coil to be energized and the counter advances one count. The normally-closed contacts of the switch cause a change of state at the appropriate input of selector 9.

In the harness wiring one side of each player control switch mentioned above is wired to ground. On the PCB terminals from each of the 6 operator switches are also connected to ground. The remaining terminals on all the option and player control switches are connected to the inputs of the three type-9312 selector devices in locations F9, H9 and J9.

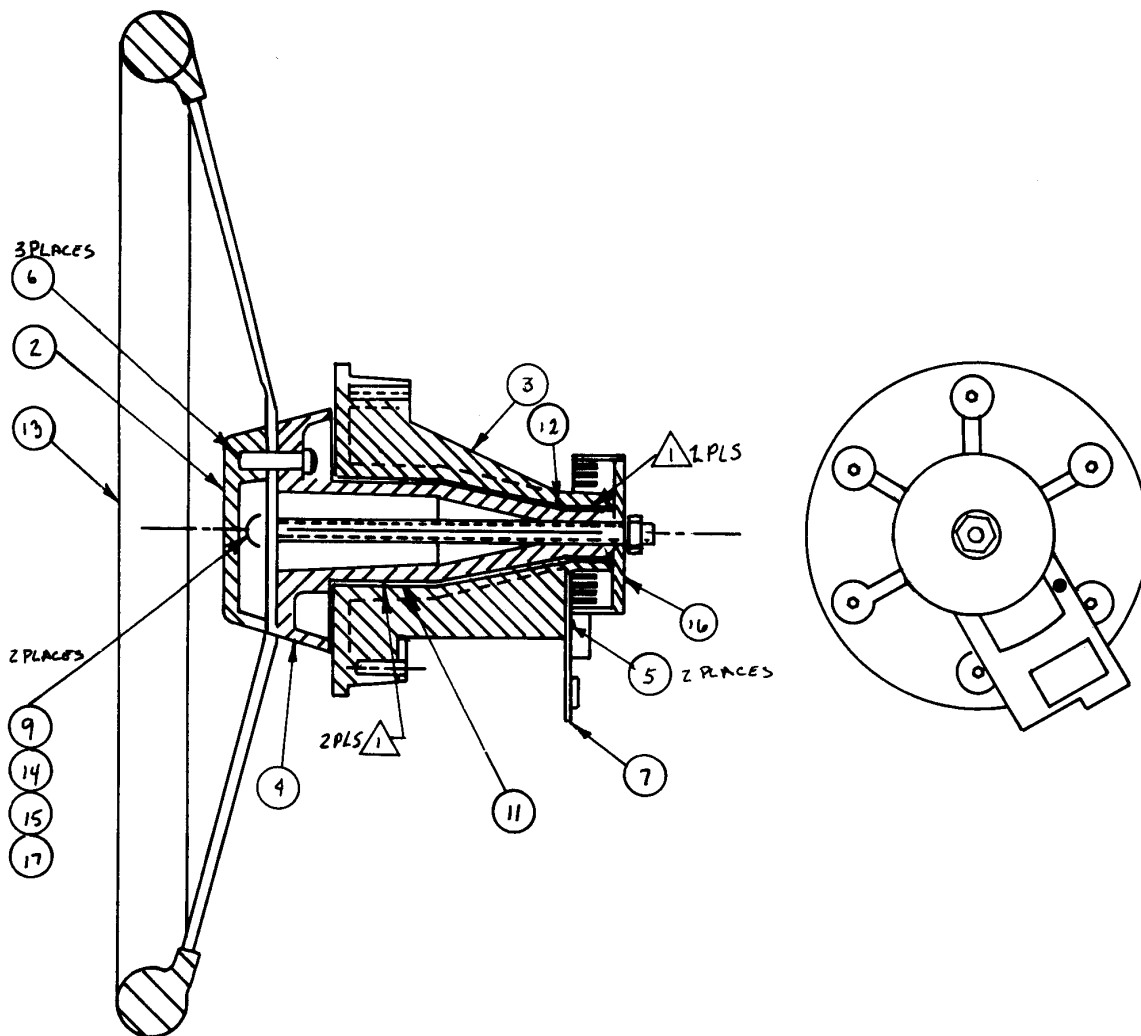

Item	Part Number	Qty.	DESCRIPTION
1	A000598-02	Ref	Steering Wheel Assembly
2	002133	1	Cover
3	000605	1	Housing
4	000606	1	Shaft
5	72-1208	2	Mach Scr, #2-56 x 1/2 Lg, Pan Hd Phil
6	72-7512	3	Mach Scr, 1/4-20 x 3/4 Lg, Fillister Hd Slotted
7	A000607	1	Printed Circuit Assembly
8	75-0700?	2	Washer, Fender, 1/4
9	76-092920	1	Bearing, Thompson (20L20-FK)
10	76-091010	1	Bearing, Thompson (10L10-FK)
11	78-40102	1	Steering Wheel, 10"
12	75-990505 S	1	Nut, 1/4-20, Nylon Lock, Shallow Pattern
13	72-9580	1	Mach Scr, 1/4-20 x 5 Lg, Truss Hd, Slotted
14	000616	1	Hub Light
15	75-055	1	Washer, 1/4" Int. Tooth, Starlock
16			

Figure 18 Steering Wheel Assembly

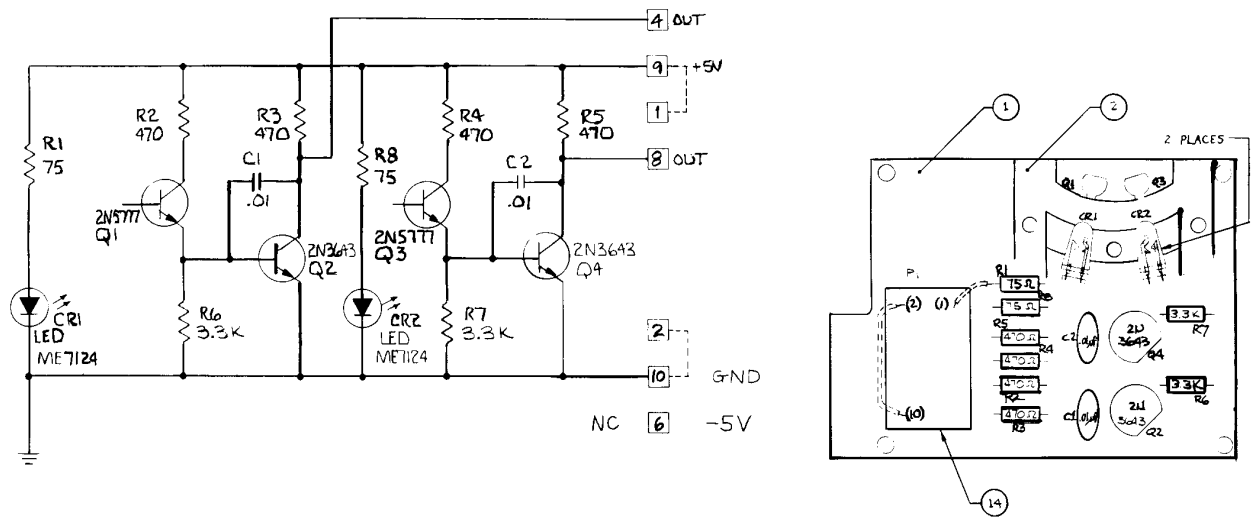

Item	Part. No.	Qty.	Description
1	000614	1	Printed Circuit Board (E)
2	001092	1	Light Mount
3	001151	Ref	Schematic Diagram
4	11750/10-5750	2	Resistor, Comp., 75 ohm, 1/4 watt, 5%
5	11471/10-5471	4	Resistor, Comp, 470 ohm, 1/4 watt, 5%
6	11332/10-5332	2	Resistor, Comp, 3.3Kohm, 1/4 watt, 5%
7	34104 /27-101103	2	Capacitor, Ceramic, .01uf
8	70006/38-2N5777	2	Transistor, 2N 5777 (Photo Darlington)
9	70000/34-2N3643	2	Transistor, 2N 3643
10	71008/38-ME7124	2	Light Emitting Diode, I.R. ME 7124
11			
12			
13			
14	80089 /79-58005	1	Connector, 10 pin, PC Mount, Amp #1-380991
15	72-1212S	1	Screw, Machine, Pan Head Phil, #2-56 x 3/4 Lg.
16	75-042	1	Washer, Split Lock #2
17	75-912S	1	Nut, Hex, #2-56
18	003749	1	Retainer, Led Light Mount

Figure 19 Steering PCB Assembly

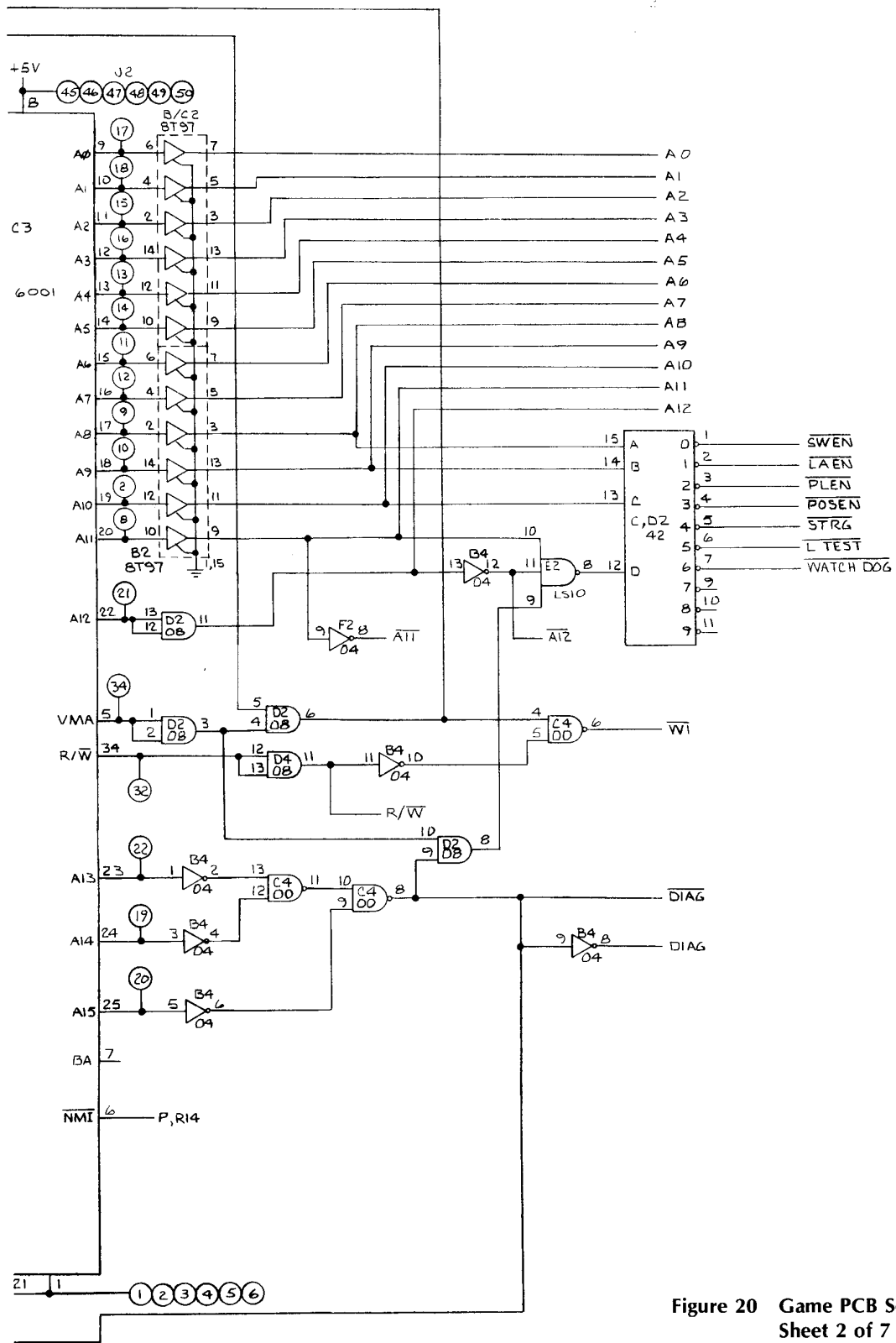
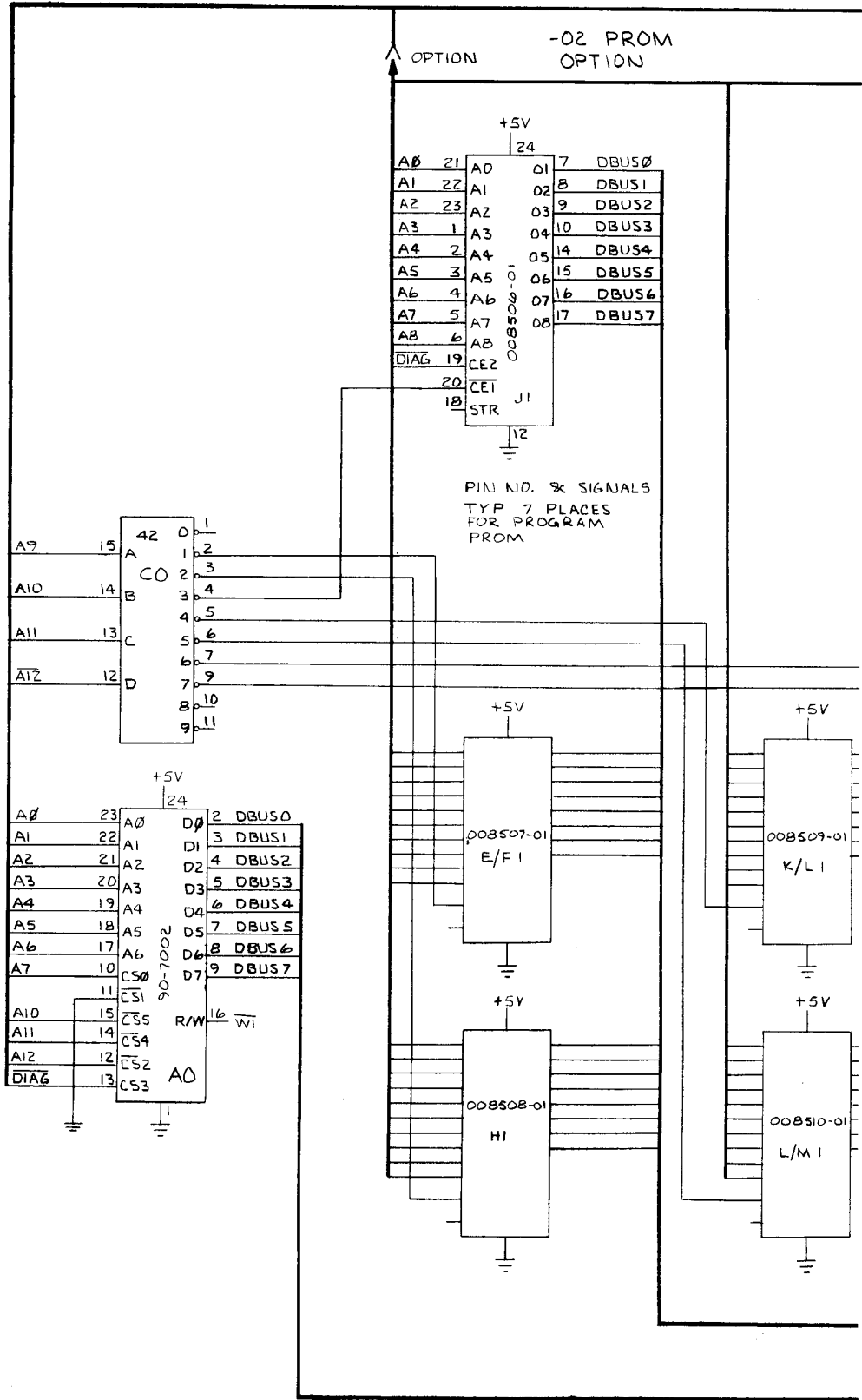

Figure 20 Game PCB Schematic Diagram
Sheet 2 of 7



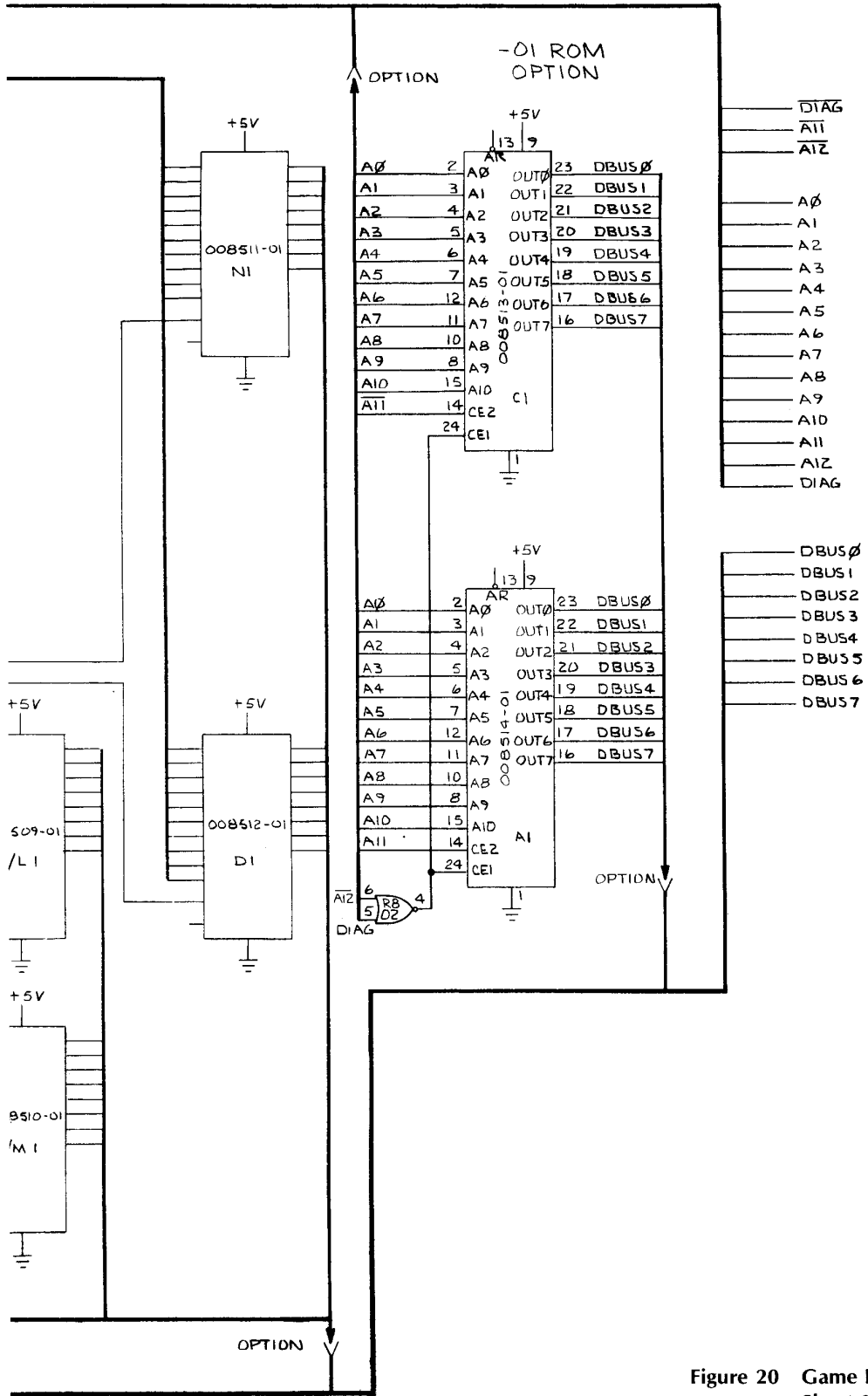

Figure 20 Game PCB Schematic Diagram
Sheet 3 of 7

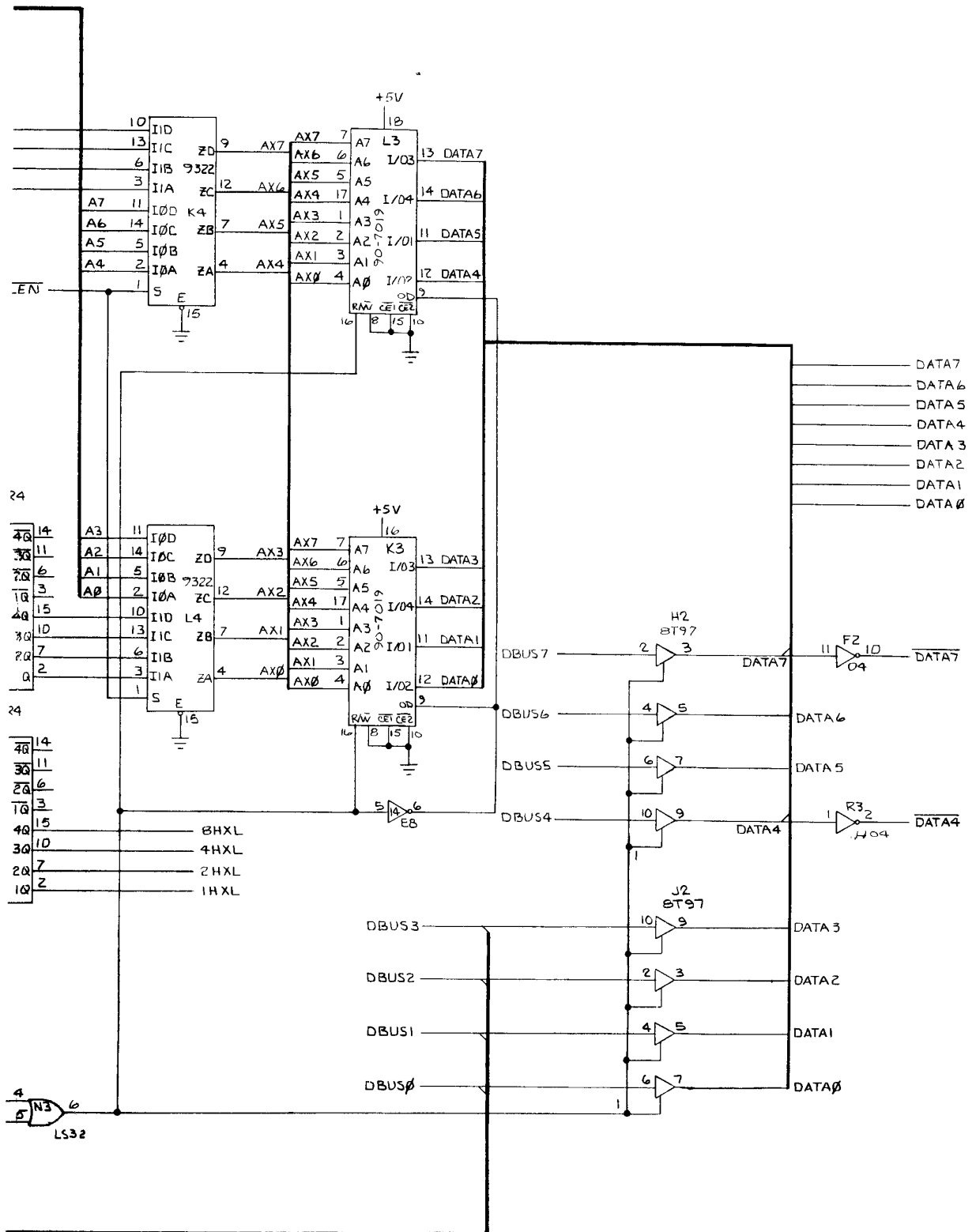
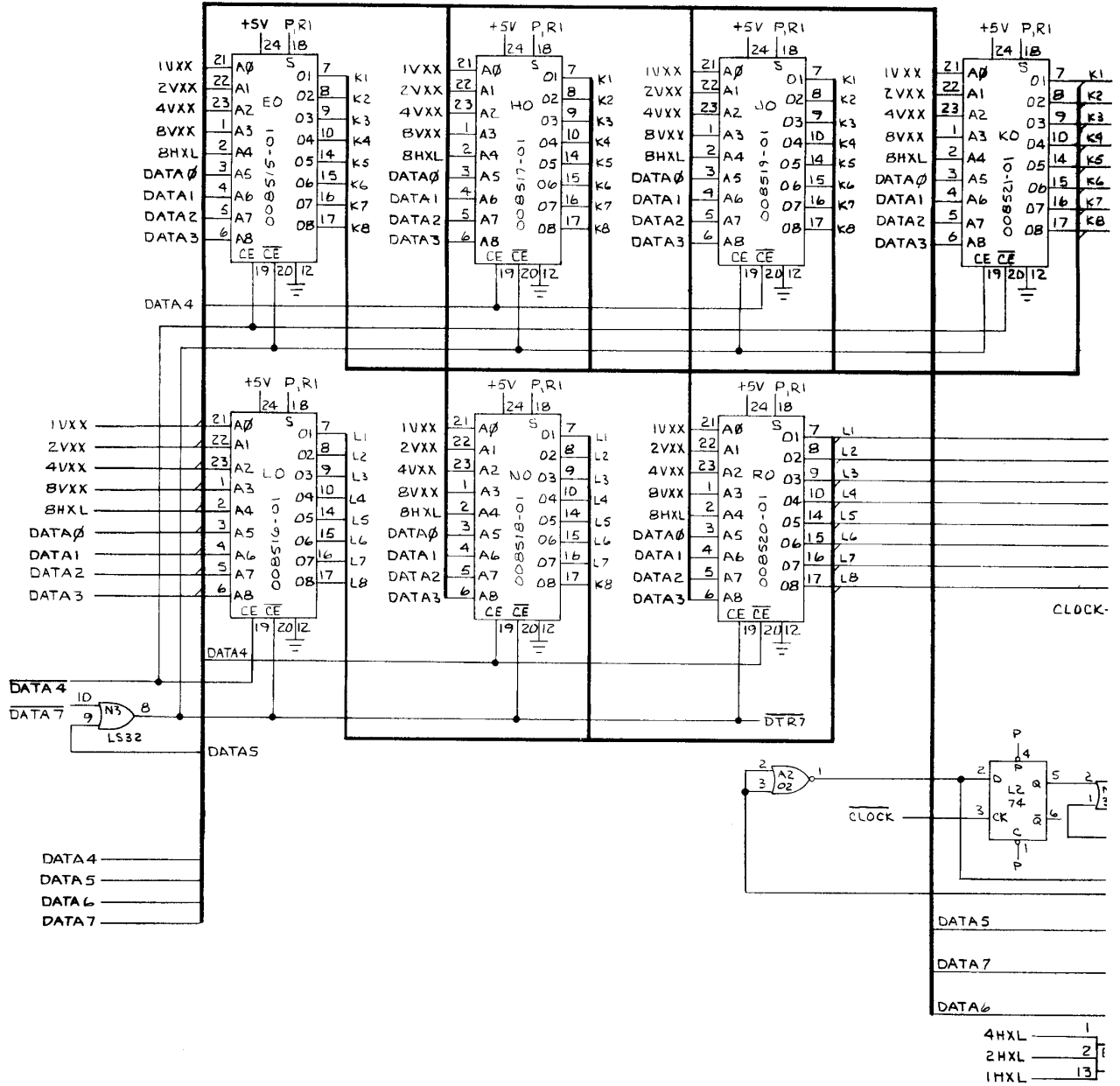

Figure 20 Game PCB Schematic Diagram Sheet 4 of 7

-01 & -02 VERSION PROM OPTION



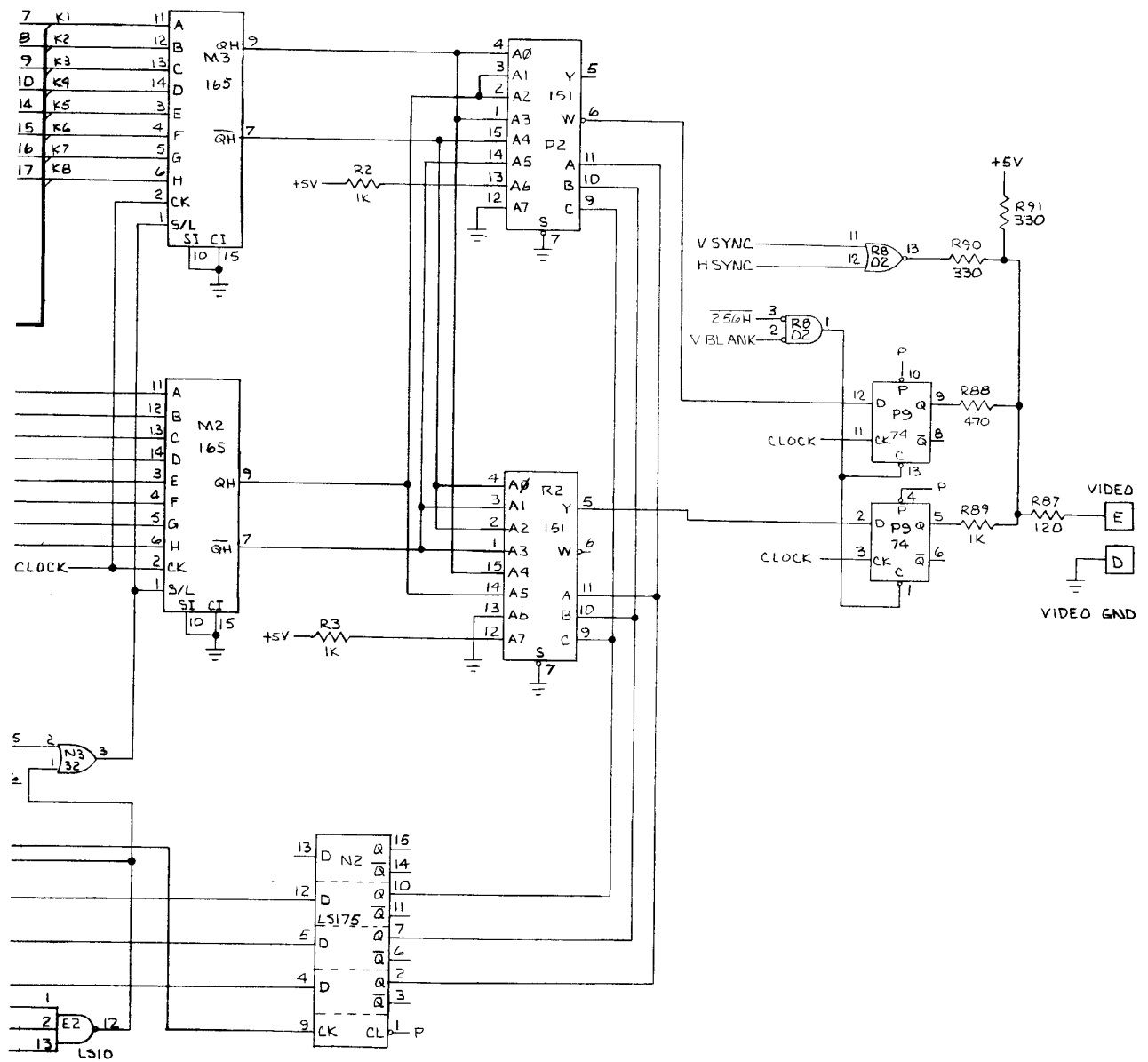
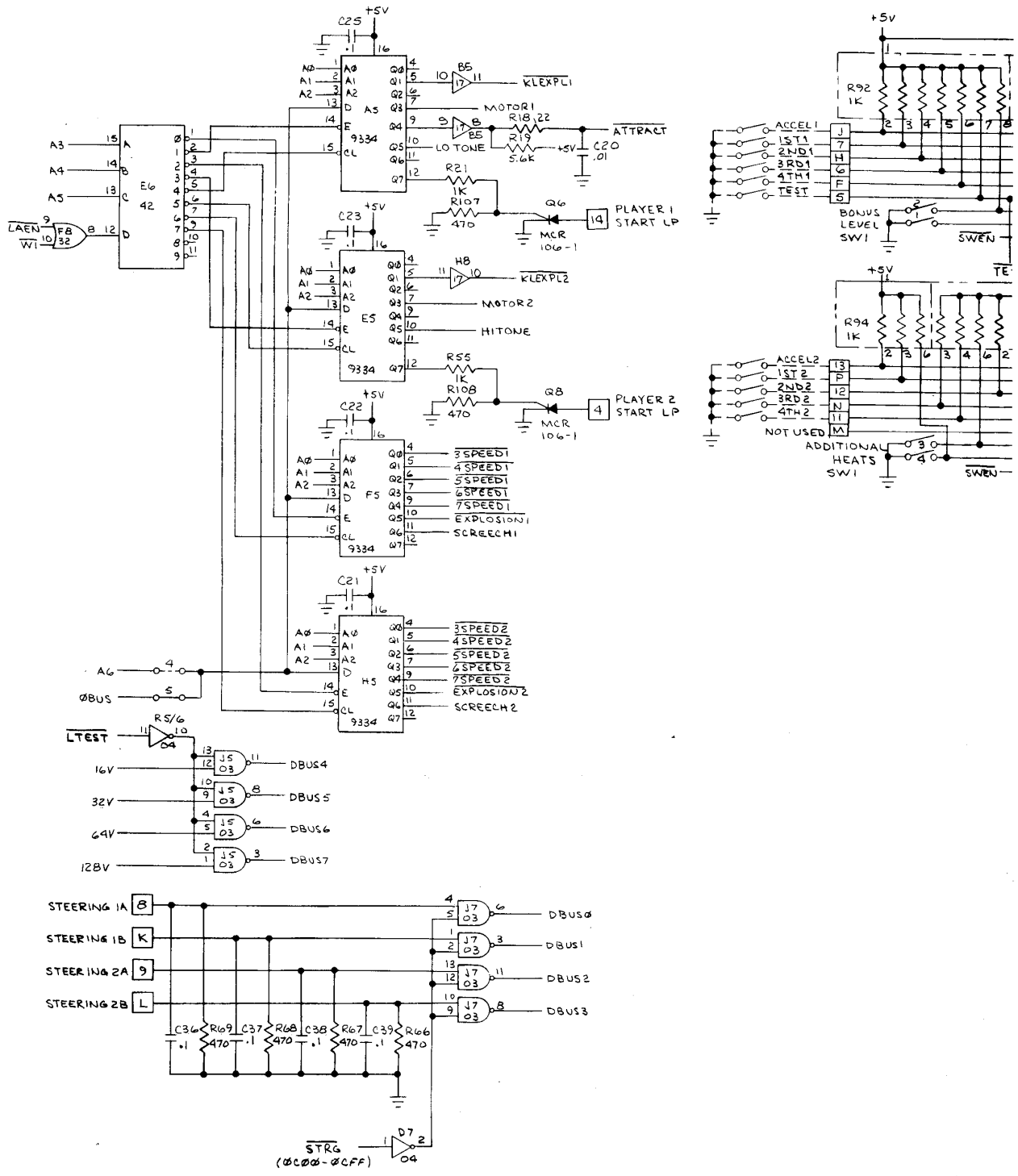

Figure 20 Game PCB Schematic Diagram
Sheet 5 of 7



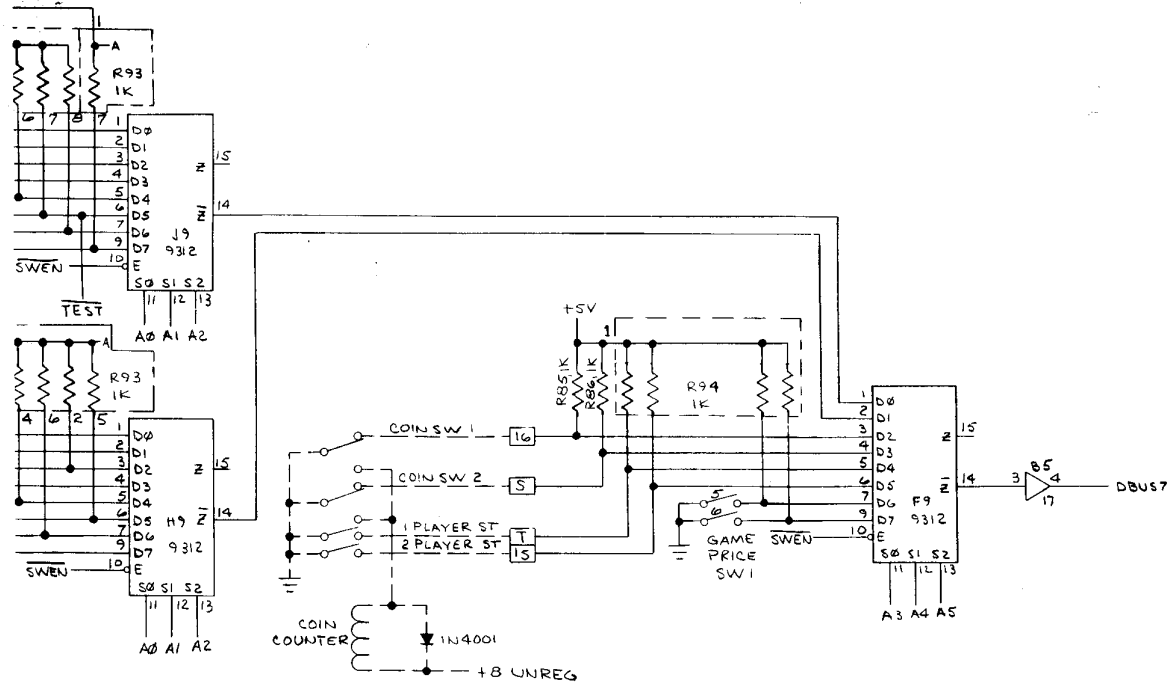
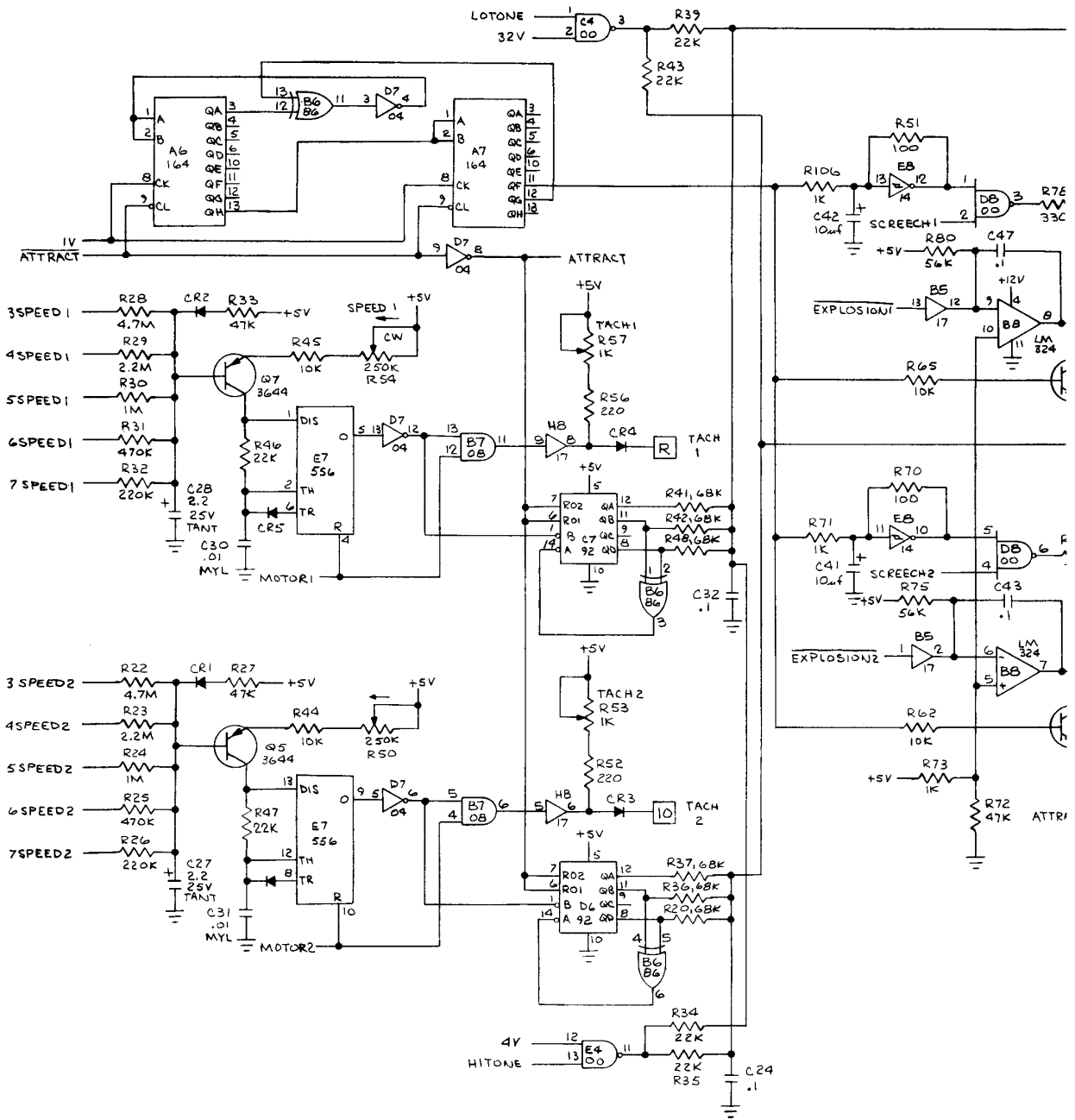

Figure 20 Game PCB Schematic Diagram
Sheet 6 of 7



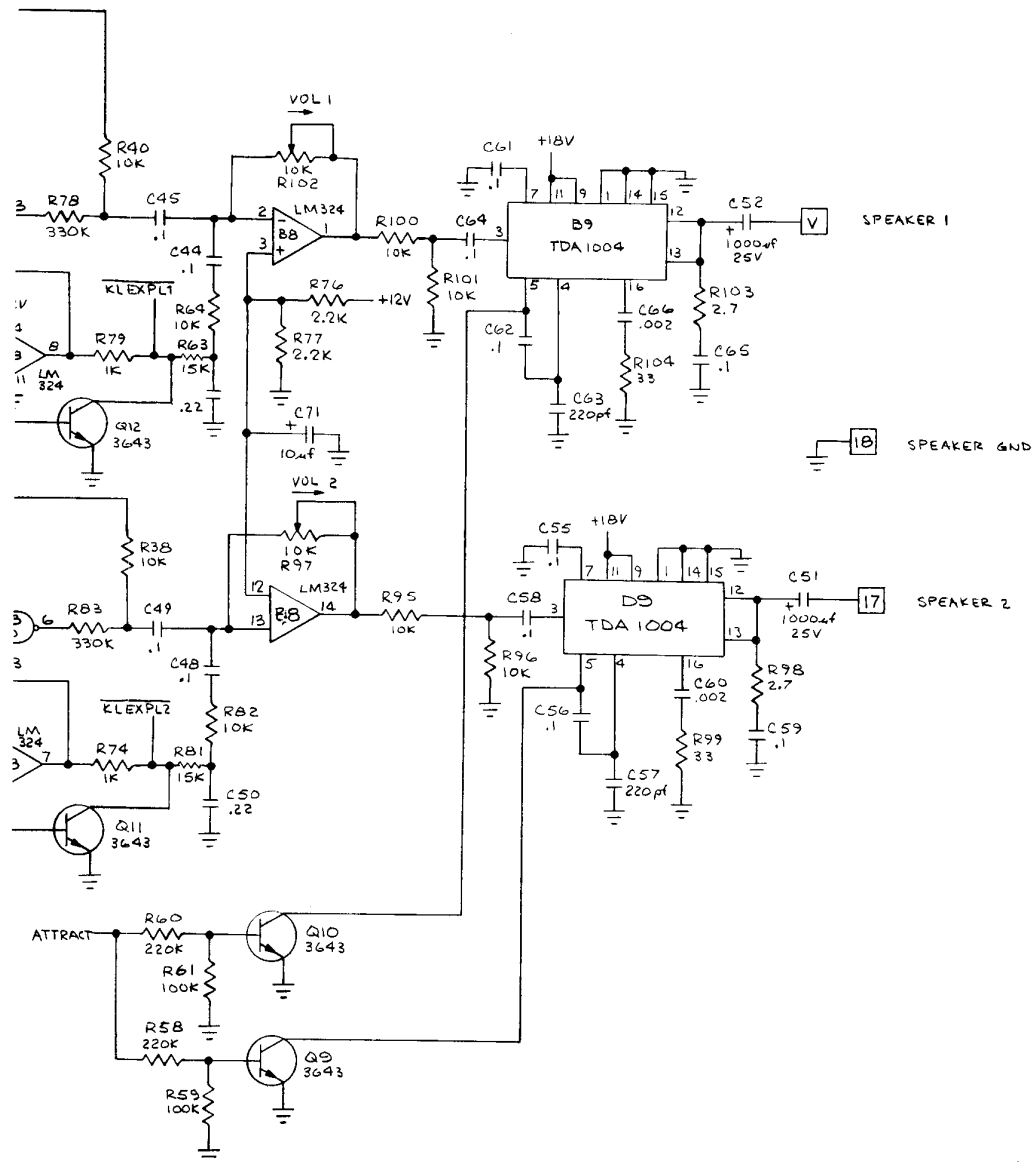

Figure 20 Game PCB Schematic Diagram
Sheet 7 of 7

Item	Part Number	Qty.	Description
28	19-315103	2	Trimpot, 10K R97,102
29	19-315254	2	Trimpot, 250K R50,54
30	19-8D9W2P0	1	Res, Wirewound, 20W, 2 OHM R84
31	10-5471	7	Res, 5%, 1/4W, 470 OHM R66-69,88,107,108
32			
33			
34	21-101103	2	Cap, Mylar, .01uF, 100V C30,31
35	24-250106	4	Cap, Electrolytic, 10uF, 25V C41,42,68,71
36	24-250227	1	" " 220uF " C17
37	24-250108	2	" " 1000uF " C51,52
38	24-250478	1	" " 4700uF " C69
39	27-250202	2	" Cer Disc .002uF " C60,66
40	27-250224	1	" " .22uF " C67
41	27-250103	1	" " .01uF " C20
42	27-250104	51	" " .1uF " C1-16,18,19,21-26, 29,32-40,43-45,47-49 53-56,58,59,61,62,64, 65,70
43	28-101221	2	" Mica, 220pF, 100V C57,63
44	28-101224	2	" Mica, .22pF, 100V C46,50
45	29-010	2	" Tant, 10V, 20%, 2.2uF C27,28
46			
47			
48			
49	31-IN914	6	Diode, 1N914 CR1-6
50	31-MR750	2	Diode, MR750 CR7,8
51			
52			
53			
54	33-2N3644	2	Transistor, 2N3644 Q5,7
55	34-2N3643	4	Transistor, 2N3643 Q9-12
56	35-MCR106-1	2	Transistor, MCR106-1 Q6,8
57			
58			
59			
60	37-7400	3	Integrated Circuit, 7400 C4,54,08
61	37-7402	2	" " 7402 A2,R8

Item	Part Number	Qty.	Description
1	005921-01	1	Drag Race P.C. Board
2	10-5101	2	Res, Carbon, 5%, 1/4W, 100 OHM R51,70
3	10-5102	16	Res, Carbon, 5%, 1/4W, 1K OHM R1-3,16,21,49,55,71,73, 74,79,85,86,89,106,109
4	10-5103	13	" " 10K " R17,38,40,44,45,62,64,65, 82,95,96,100,101
5	10-5104	2	" " 100K " R59,61
6	10-5105	2	" " 1M " R24,30
7	10-5121	1	" " 120 " R87
8	10-5153	2	" " 15K " R63,81
9	10-5220	2	" " 22 " R18,105
10	10-5221	4	" " 220 " R4,5,52,56
11	10-5222	2	" " 2.2K " R76,77
12	10-5223	6	" " 22K " R34,35,39,43,46,47
13	10-5224	4	" " 220K " R26,32,58,60
14	10-5225	2	" " 2.2M " R23,29
15	10-5272	2	" " 2.7K " R98,103
16	10-5330	2	" " 33 " R99,104
17	10-5331	4	" " 330 " R14,15,90,91
18	10-5334	2	" " 330K " R78,83
19	10-5472	8	" " 4.7K " R6-13
20	10-5473	3	" " 47K " R27,33,72
21	10-5474	2	" " 470K " R25,31
22	10-5475	2	" " 4.7M " R22,28
23	10-5562	1	" " 5.6K " R19
24	10-5563	2	" " 56K " R75,80
25	10-5683	6	" " 68K " R20,36,37,41,42,48
26	19-009	3	Res, Network 1K R92,93,94
27	19-315102	2	Trimpot, 1K R53,57

Figure 21 Game PCB Assembly Drawing and Parts List

Item	Part Number	Qty.	Description
99	62-001	1	Switch Momentary SPST SW2
100	66-118P1T	1	Switch, Dip 8 Stations SPST SW1
101			
102			
103			
104	72-1608C	2	Screw, Pan Head, Phil., #6-32 x 1/2 Lg., Cres
105	75-016S	2	Washer, Flat, Reg., Pat., #6, Steel
106	75-056	2	Washer, Lock, Int., Star, #6
107	75-916C	2	Nut, Hex, #6-32 Cres.
108	78-06001	1	Heatsink (LM323)
109	78-06022	2	Heatsink (TDA 1004)
110	78-13016	A/R	Cement, (Heatsink TDA1004)
111	78-16005	1	Silipad (LM323)
112	79-42040	1	Socket, 40 Pin, Med. Insertion C3
113			
114			
115			
116	90-102	1	Crystal, 12.096 MHZ Y1
117	90-6001	1	Integrated Circuit, Microprocessor C3
118	90-7002	1	Ram, MC6810L-1 A0
119	90-7019	3	Ram, 2111A-4 K3,L3,N7
120			
121			
122			
123	008505-01	1	Drag Race Sync Prom L8
124			
125	008515-01	1	Drag Race Character Prom 1 E0
126	008516-01	1	Drag Race Character Prom 2 L0
127	008513-01	1	Drag Race Program Rom 1 C1
128	008514-01	1	Drag Race Program Rom 2 A1
129	008517-01	1	" " Character Prom 3 H0
130	008518-01	1	" " " " 4 N0
131	008519-01	1	" " " " 5 J0
132	008520-01	1	" " " " 6 R0
133	008521-01	1	" " " " 7 K0

Item	Part Number	Qty.	Description
62	37-7403	2	Integrated Circuit, 7403 J5,J7
63	37-7404	4	" " 7404 F2,B4,R5/6, D7
64	37-74H04	1	" " 74H04 R3
65	37-7408	3	" " 7408 D2,D4,B7
66	37-74LS10	1	" " 74LS10 E2
67	37-7414	1	" " 7414 E8
68	37-7417	2	" " 7417 B5,H8
69	37-7420	1	" " 7420 K8
70	37-7432	1	" " 7432 F8
71	37-74LS32	1	" " 74LS32 N3
72	37-7437	1	" " 7437 H3
73	37-7442	4	" " 7442 CO,C/D2,F6,E6
74	37-7474	4	" " 7474 L2,F4,R6,P9
75	37-7483	4	" " 7483 K5,L5,M5,N5
76	37-7486	1	" " 7486 B6
77	37-7492	3	" " 7492 R4,D6, C7
78	37-7493	1	" " 7493 J4
79	37-74151	2	" " 74151 P2,R2
80	37-74164	2	" " 74164 A6,A7
81	37-74165	2	" " 74165 M2,M3
82	37-74175	1	" " 74175 I9
83	37-74LS175	7	" " 74LS175 N2,M4,N4,K6,L6,M6
84	37-74279	1	" " 74279 F4
85	37-8T28	2	" " 8T28 E3,F3
86	37-8T97	4	" " 8T97 B2,B/C2,H2,J2
87	37-9312	3	" " 9312 F9,H9,J9
88	37-9316	4	" " 9316 P5,R5,K7,L7
89	37-9322	4	" " 9322 K4,L4,M7,M8
90	37-9334	4	" " 9334 A5,E5,F5,H5
91	37-556	1	" " 556 E7
92	37-IM324	1	" " IM324 B8
93	37-IM323	1	" " IM323
94	37-7812	1	Regulator, 7812 Q13
95	37-TDA1004	2	Regulator, TDA1004 B9,D9
96			Audio Amp
97			
98			

Figure 21 Game PCB Assembly Drawing and Parts List

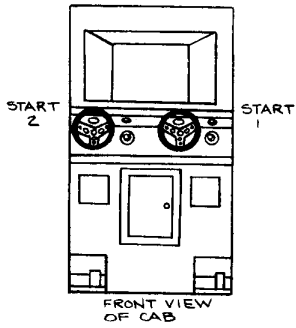

44 POS EDGE CONNECTOR

1	GRD	R/GN
A	GRD	BK/RGN
2	+10V UNREG	R/BK
B	+10V UNREG	R/BK
3	+5V	R
C	GRD	BK/GN
4	START 2 LP	BN/W
D	VIDEO GRD	W/GN
5	TEST	W
E	VIDEO	Y
6	3RD 1	W/OR
F	4TH 1	W/BK
7	1ST 1	W/BU
H	2ND 1	W/Y
8	STEERING 1A	W/GY
J	ACCEL 1	BU/BK
9	STEERING 2A	GY/W
K	STEERING 1B	W/V
10	TACH 2	R/W
L	STEERING 2B	V/W
11	4TH 2	BK/W
M		
12	2ND 2	Y/W
N	3RD 2	OR/W
13	ACCEL 2	BU/R
P	1ST 2	BU/W
14	START 1 LP	BN/BK
R	TACH 1	W/R
15	START 2 NO.	GY/BK
S	COIN 2 N.C.	Y

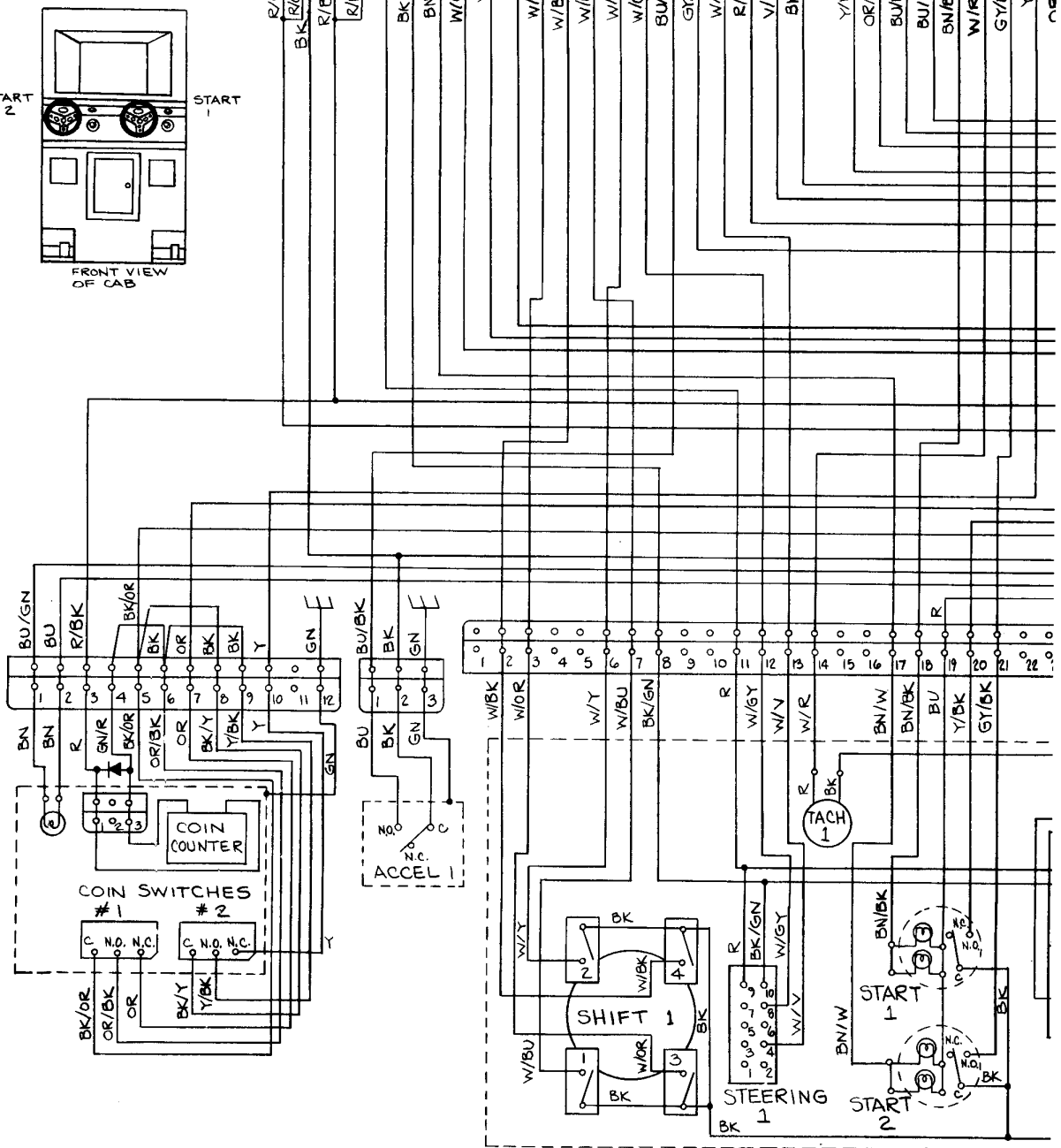

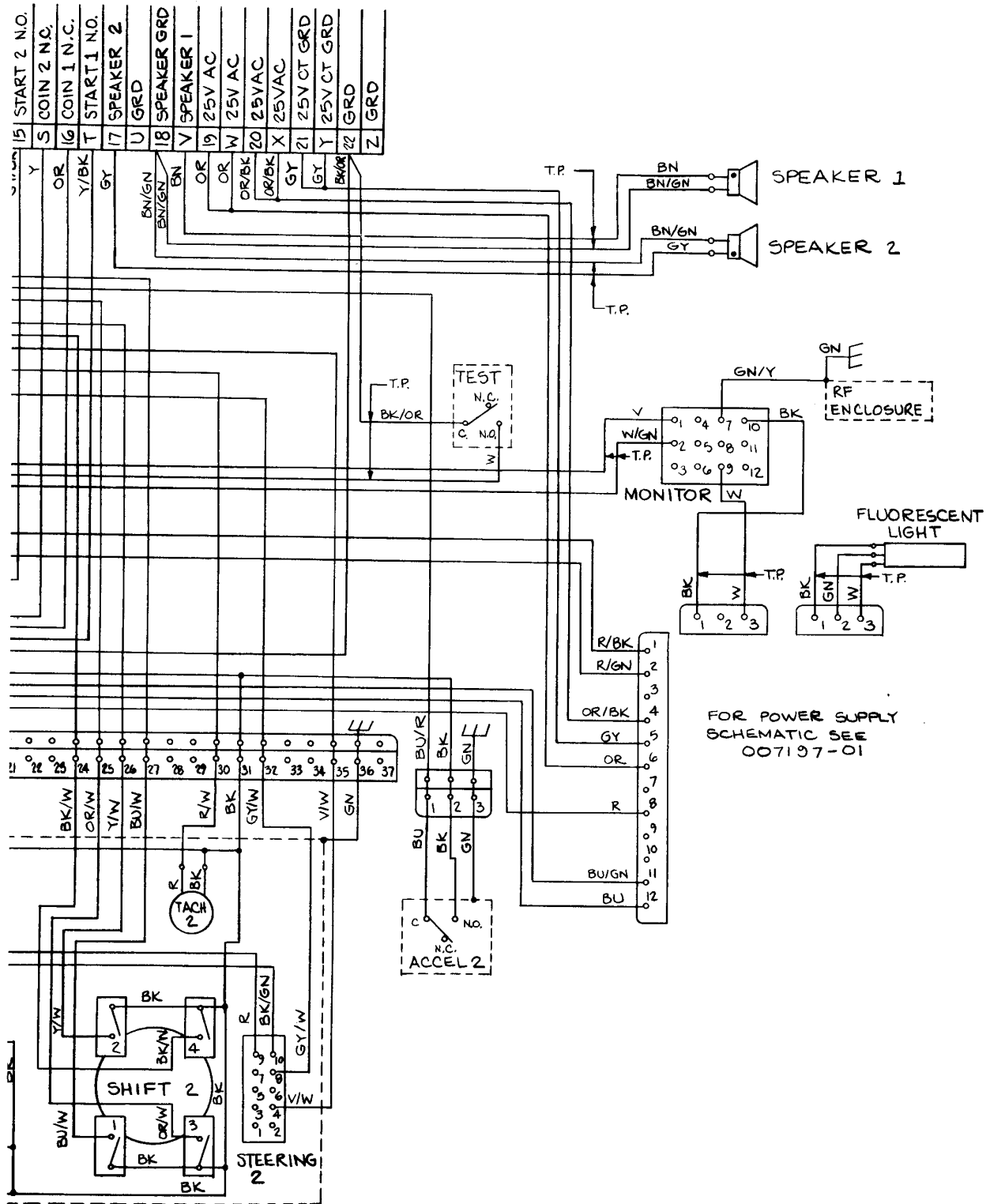
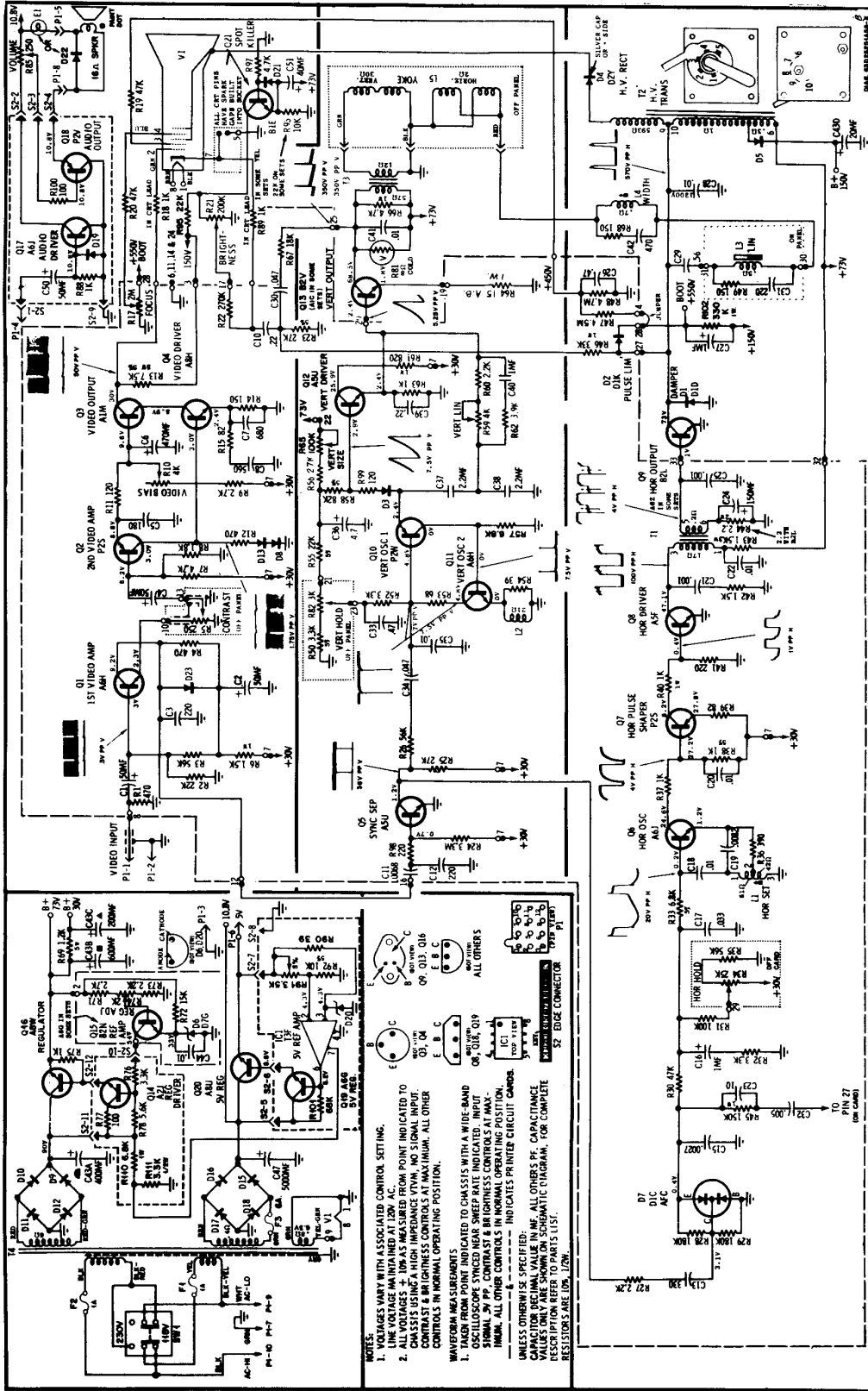

Figure 22 Harness Schematic



SCHEDULED PRT FOR 37K	
74 2-74	
24.8 PAGES 10 TO 15	
A	REV 000
DATE 11-19-75	
DESIGNED BY: [Signature]	
DRAWN BY: [Signature]	
CHECKED BY: [Signature]	
APPROVED BY: [Signature]	
MOTOROLA DATA PRODUCTS CAROL STREAM, ILL.	
XMT001-008	
XMT001-008	
DIAGRAM SCHEMATIC	
DRAWING NUMBER: [Number]	
FORM 63020201A08	

Figure 23 Motorola TV Monitor Schematic Diagram

The switch sensing circuit operates only when the $\overline{\text{SWEN}}$ (switch enable) signal, applied at F9 pin 10, is low. During operation of the circuit the A0 through A5 signals cause selectors F9, H9, J9 to produce output signals. In this way each switch is sensed, and the result of the sensing appears on the DBUS7 signal.

Steering Sensing

The four signals STEERING 1A through STEERING 2B originate at two small printed circuit boards on the steering wheel assemblies mounted on the backside of the dashboard. Figure 18 shows the mechanical details of the steering wheel assembly. Each assembly has one printed circuit board (item 7 in the illustration) A hub (item 16) is bolted onto the end of the steering wheel shaft. Many slots have been cut in the outside rim of the hub. The width of the slots is approximately equal to the width of the tooth-like projections remaining between the slots. The board is attached to the hub end of the stationary housing that holds the steering wheel shaft.

The rim of the hub moves across the surface of the board, through a curved gap formed by the board components, when a player turns the steering wheel. Figure 19 shows the placement of components on the board. A pair of light-emitting diode (LED) light sources (CR1 and CR2) is positioned on one side of the curved gap, and a corresponding pair of phototransistors (Q1 and Q3) is positioned on the other side of the gap, directly opposite the LEDs.

The circuitry built on the board keeps the LEDs in conduction (producing light) all the time, but the phototransistors will conduct only when light passes through a slot in the hub. With this arrangement, square-wave types of waveforms appear on the STEERING signals whenever a player turns a steering wheel. This is the case because the phototransistors alternately conduct and cease to conduct as the tooth-like projections pass in front of the phototransistors, blocking their light path. The frequency of the square wave will be proportional to the rate of turning of the steering wheel—higher turning rates produce higher frequency waveforms. The game's circuitry detects direction of rotation (clockwise or counterclockwise) by examining the time relationship between the pair of square waves coming from a board (between STEERING 1A and 1B, or between STEERING 2A and 2B).

The $\overline{\text{STRG}}$ is a command signal that can block the STEERING waveform information from reaching the game's control circuitry.

Line Test Gating

The $\overline{\text{LTEST}}$ (line test) signal controls four gates in location J5. These gates produce signals that tell the game's control circuitry where the TV tube's electron beam is scanning vertically at any one moment. This timing information is important so that, for example, data for the upper car are updated only while the lower car's image is being written on the TV screen.

Latch Group (left half of page)

The four type-9334 latch devices in locations A5, E5, F5 and H5 produce digital signals that are used to drive the sound generation circuitry and to light the lamps behind the start pushbuttons. The type-7442 4-line to 10-line decoder device in E6 is under control of the $\overline{\text{LAEN}}$ (latch enable) and $\overline{\text{W1}}$ signals. It decodes the A3, A4, and A5 signals to determine which latch will be selected. The type MR106 SCR devices Q6 and Q8 provide lamp current.

H. SOUND CIRCUITRY (SHEET 7 OF SCHEMATIC)

Noise Generator

The type-74164 shift register devices in locations A7 and A6 form a digital noise generator. It is driven by the 1V timing signal from the sync countdown chain, and is held in a "clear" state (no noise) during the attract mode.

Motor Sound Generators

The 3 SPEED through 7 SPEED signals (produced on sheet 6) are applied to weighted resistor networks. The common side of the resistors connects to the base of a transistor. Its level of conduction depends upon the states of the various SPEED digital signals. The transistor's collector connects to a type-556 device that functions as an audio oscillator, and, via a resistor, to a capacitor tied to ground. With this arrangement the output frequency of the 556 is determined by how much charging current the transistor supplied to the capacitor. The output from the 556 drives a type-7492 counter, and the counter's outputs produce three digital signals that are combined through individual summing resistors. The output from the 556 also drives the tachometer through a type-7417 buffer.

Sound Mixing

The type-LM324 amplifiers in location B8, together with transistor Q12, perform sound mixing functions for the sounds to be produced by speaker 1. The LM324 amplifiers in B8, together with Q11, perform these functions for speaker 2. The sounds

mixed in originate from two signals, as follows. The SCREECH signal is produced when a dragster touches a side rail, or is in a "Wheelie," and EXPLOSION when an engine blows up, or a modified EXPLOSION when the chute is deployed.

Two TONE signals are also mixed in. A higher pitch tone is produced by gating the 8V timing signal and the TONE 1 signal; the 4V and TONE 2 signals are gated to produce a lower pitch tone. The TONE signals are produced only at the start-off of each heat, during the Christmas-tree sequence.

The results of the mixing appear as a single signal; for speaker 1's circuit this is the signal applied at B8 pin 2, and for speaker 2's circuit the signal at B8 pin 13.

Output Drive Stages (right side of page)

Each speaker's output drive stage consists of a type-LM324 low-level amplifier followed by a type-TDA 1004 audio amplifier. A potentiometer is included in the feedback circuit of each low-level amplifier (R102 for speaker 1 and R97 for speaker 2). These provide the manual speaker volume adjustments described in Section C of Chapter 3 in this manual.