

This document has been downloaded from:



The largest resource for amusement machines  
documentation on the world wide web!



**FLIPPERSPILL.COM**

2nd PRINTING AUG

# SEGA

## *F355 challenge*™

Deluxe Version

# OWNER'S MANUAL



SEGA ENTERPRISES, INC. USA

MANUAL NO. 4201-6507-01

# VISIT OUR WEBSITE!

The screenshot shows a Netscape browser window displaying the SegaService.com website. The browser's address bar shows the URL <http://www.seuservice.com/>. The website's navigation menu on the left includes links for 'what's new', 'manuals', 'bulletins', 'assemblies', 'Search', 'bulletin Sign-up', 'register name', 'staff', 'Darl's Office', 'tech. service', 'warranty policy', 'corporate info', 'home page', 'future technologies', 'plugins', and 'non-framed page'. Contact information for Sega Enterprises Inc., USA is provided: Service Department, phone 415.701.8580, fax 415.701.6594.

The main content area features a large 'SEGA SERVICE' logo and a list of services: 'Bulletins', 'Darl's Office', 'Game Manuals', 'Search', and 'What's New'. A portrait of a man is accompanied by the text 'Ask Dave!'. A visitor counter indicates that 5564 people have visited the page since 3/16/01. A message encourages visitors to contact 'Darl Davidson@seu.sega.com' for questions or comments.

At the bottom, a banner states 'THIS WEB SITE POWERED BY WebSTAR 4.3 Mac OS'. A list of links is provided: [\[what's new\]](#), [\[manuals\]](#), [\[bulletins\]](#), [\[assemblies\]](#), [\[Search\]](#), [\[staff\]](#), [\[Darl's office\]](#), [\[technical service\]](#), [\[customer service\]](#), [\[corporate info\]](#), [\[plugins\]](#), [\[Non-framed page\]](#). A note states 'You will need the following items to view this page in its entirety.' Below this, three icons are shown: 'Get Acrobat Reader' for 'All Platforms', 'GET Microsoft Internet Explorer' for 'Windows', and 'GET Microsoft Internet Explorer' for 'Macintosh'.

## **BEFORE USING THE PRODUCT, BE SURE TO READ THE FOLLOWING:**

### **To maintain the safety:**

To ensure the safe usage of the product, be sure to read the following before using the product. The following instructions are intended for the users, operators and the personnel in charge of the operation of the product. After carefully reading and sufficiently understanding the warning displays and cautions, handle the product appropriately. Be sure to keep this manual nearby the product or elsewhere convenient for referring to it when necessary.

Herein, explanations which require special attention are enclosed with dual lines. Depending on the potentially hazardous degrees, the terms of WARNING, CAUTION, etc. are used. Be sure to understand the contents of the displays before reading the text.



**WARNING!**

Indicates that mishandling the product by disregarding this warning will cause a potentially hazardous situation which can result in death or serious injury.



**CAUTION!**

Indicates that mishandling the product by disregarding this caution will cause a slight hazardous situation which can result in personal injury and or material damage.

### **For the safe usage of the product, the following pictographs are used:**



Indicates “HANDLE WITH CARE.” In order to protect the human body and equipment, this display is attached to places where the Owner’s Manual and or Service Manual should be referred to.

#### **○ Perform work in accordance with the instructions herein stated.**

Instructions for work are explained by paying attention to the aspect of accident prevention. Failing to perform work as per the instructions can cause accidents. In the case where only those who have technical expertise should perform the work to avoid hazardous situation, the instructions herein state that the serviceman should perform such work.

#### **○ Be sure to turn off power before working on the machine.**

To prevent electric shock, be sure to turn off power before starting the work in which the worker touches the interior of the product. If the work is to be performed in the power-on status, the Instruction Manual herein always states to that effect.

#### **○ Be sure to ground the Earth Terminal (this, however, is not required in the case where a power cord with earth is used).**

This product is equipped with the Earth Terminal. When installing the product, Connect the Earth Terminal to the “accurately grounded indoor earth terminal” by using an earth wire. Unless the product is grounded appropriately, the user can be subject to electric shock. After performing repair, etc. for the Control equipment, ensure that the Earth Wire is firmly connected to the Control equipment.

#### **○ Ensure that the Power Supply used is equipped with an Earth Leakage Breaker.**

This product does not incorporate the Earth Leakage Breaker. Using a power supply which is not equipped with the Earth Leakage Breaker can cause a fire when earth leakage occurs.

#### **○ Be sure to use fuses which meet the specified rating. (only for the machines which use fuses).**

Using fuses exceeding the specified rating can cause a fire and electric shock.

○ **Specification changes (removal of equipment, conversion and addition) not designated by SEGA are not allowed.**

The parts of the product include warning labels for safety, covers for personal protection, etc. It is very hazardous to operate the product by removing parts and or modifying the circuits. Should doors, lids and protective parts be damaged or lost, refrain from operating the product, and contact where the product was purchased from or the office herein stated. SEGA shall not be held responsible for any accidents, compensation for damage to a third party, resulting from the specifications not designated by SEGA.

○ **Ensure that the product meets the requirements of appropriate Electrical Specifications.**

Before installing the product, check for Electrical Specifications. SEGA products have a nameplate on which Electrical Specifications are described. Ensure that the product is compatible with the power supply voltage and frequency requirements of the location. Using any Electrical Specifications different from the designated Specifications can cause a fire and electric shock.

○ **Install and operate the product in places where appropriate lighting is available, allowing warning labels to be clearly read.**

To ensure safety for the customers, labels and printed instructions describing potentially hazardous situation are applied to places where accidents can be caused. Ensure that where the product is operated has sufficient lighting allowing the warnings to be read. If any label is peeled off, apply it again immediately. Please place an order with where the product was purchased from or the office herein stated.

○ **When handling the Monitor, be very careful. (Applies only to the product w/monitor.)**

Some of the monitor (TV) parts are subject to high tension voltage. Even after running off power, some portions are still subject to high tension voltage sometimes. Monitor repair and replacement should be performed only by those technical personnel who have knowledge of electricity and technical expertise.

○ **Be sure to adjust the monitor (projector) properly. (Applies only to the product w/monitor.)**

Do not operate the product leaving on-screen flickering or blurring as it is. Using the product with the monitor not properly adjusted may cause dizziness or a headache to an operator, a player, or the customers.

○ **When transporting or reselling this product, be sure to attach this manual to the product.**

In the case where commercially available monitors and printers are used in this product, only the contents relating to this product are explained herein. Some commercially available equipment has functions and reactions not stated in this manual. Read this manual together with the specific Instruction Manual of such equipment.

- Descriptions herein contained may be subject to improvement changes without notice.
- The contents described herein are fully prepared with due care. However, should any question arise or errors be found, please contact SEGA.

**INSPECTIONS IMMEDIATELY AFTER TRANSPORTING THE PRODUCT TO THE LOCATION.**

Normally, at the time of shipment, SEGA products are in a status allowing for usage immediately after transporting to the location. Nevertheless, an irregular situation may occur during transportation. Before turning on power, check the following points to ensure that the product has been transported in a satisfactory status.

- Are there any dented portions or defects (cuts, etc.) on the external surfaces of the cabinet?
- Are Casters and Adjusters, damaged?
- Do the power supply voltage and frequency requirements meet with those of the location?
- Are all wiring connectors correctly and securely connected? Unless connected in the correct direction, connector connections can not be made accurately. Do not insert connectors forcibly.
- Do power cords have cuts and dents?
- Do the fuses used meet specified rating? Is the Circuit Protector in an energized status?
- Are all accessories available?
- Can all Doors and Lids be opened with the Accessory keys? Can Doors and Lids be firmly closed?

---

---

## TABLE OF CONTENTS

---

---

BEFORE USING THE PRODUCT, BE SURE TO READ THE FOLLOWING:

### TABLE OF CONTENTS

#### INTRODUCTION OF THE OWNER'S MANUAL

1. HANDLING PRECAUTIONS .....	1
2. PRECAUTIONS CONCERNING INSTALLATION LOCATION .....	2 - 3
3. OPERATION .....	4 - 5
4. NAME OF PARTS .....	6
5. ACCESSORIES .....	7 - 9
6. ASSEMBLING AND INSTALLATION .....	10 - 19
7. PRINTER (OPTIONAL).....	20
7 - 1 OPERATION WITH THE PRINTER ATTACHED.....	20 - 21
7 - 2 SETTING THE ROLL PAPER.....	21 - 24
7 - 3 CLEANING OF THE PRINTER HEAD.....	25
7 - 4 COUNTERMEASURES AGAINST PAPER JAM.....	26
8. PRECAUTIONS TO BE HEDED WHEN MOVING THE MACHINE .....	27 - 29
9. HANDLE MECHA.....	30
9 - 1 ADJUSTING OR REPLACING THE V.R. ....	30 - 33
9 - 2 GREASING.....	33
9 - 3 REPLACING PADDLE (WING) SHIFT SWITCH.....	34 - 35
10. 6-SPEED SHIFT.....	36
10- 1 REMOVING THE SHIFT LEVER.....	36 - 37
10- 2 REPLACING THE SWITCH.....	38
11. ACCELERATOR & BRAKE.....	39
11- 1 ADJUSTING AND REPLACING THE V.R. ....	39 - 40
11- 2 GREASING.....	40
12. CLUTCH PEDAL.....	41
12- 1 REMOVING THE CLUTCH PEDAL.....	41 - 42
12- 2 VOLUME ADJUSTMENT/REPLACEMENT.....	43
12- 3 GREASING.....	44
13. COIN SELECTOR.....	45 - 48
14. MONITOR.....	49
14- 1 CAUTIONS AND WARNINGS CONCERNING THE SAFETY FOR HANDLING THE MONITORS.....	49 - 51
14- 2 CAUTIONS TO BE HEDED WHEN CLEANING THE CRT SURFACES.....	51
14- 3 ADJUSTMENT METHOD.....	52 - 53
14- 4 CLEANING THE MONITOR GLASS.....	54 - 56
15. REPLACING THE FLOURESCENT LAMP, AND LAMPS.....	57 - 65
16. PERIODIC INSPECTION TABLE.....	66 - 67
17. TROUBLESHOOTING.....	68 - 70
18. GAME BOARD.....	71
18 - 1 TAKING OUT THE BOARD.....	71 - 72
18 - 2 COMPOSITION OF GAME BOARD.....	72
19. DESIGN RELATED PARTS.....	73
20. PARTS LIST.....	74 - 143
21. WIRE COLOR CODE TABE.....	144
22. WIRING DIAGRAM.....	145-149

---

---



## SPECIFICATIONS

Installation Space	: 1,310 mm (W) X 2,830 mm (D) (51.6 in. X 111.4 in.)
Height	: 2,660 mm (104.7 in.)
Weight	: 370 kg. (815.7 lbs.)
Power, maximum current	: 600 W 6.7 A (AC 110V 50 Hz AREA) 600 W 6.7 A (AC 110V 60 Hz AREA) 580 W 6.0 A (AC 120V 60 Hz AREA) 590 W 3.5 A (AC 220V 50 Hz AREA) 580 W 3.4 A (AC 220V 60 Hz AREA) 600 W 3.4 A (AC 230V 50 Hz AREA) 580 W 3.2 A (AC 230V 60 Hz AREA) 600 W 3.2 A (AC 240V 50 Hz AREA) 590 W 3.2 A (AC 240V 60 Hz AREA)
For TAIWAN	
Power, current	: 600 W 6.7 A (MAX.) 340 W 4.0 A (MIN.)
MONITOR	: 50 TYPE COLOR MONITOR

## INTRODUCTION OF THE OWNERS MANUAL

This Owner's Manual is intended to provide detailed descriptions together with all the necessary information covering the general operation of electronic assemblies, electromechanicals, servicing control, spare parts, etc. as regards the product, **F355 CHALLENGE DX TYPE.**

This manual is intended for the owners, personnel and managers in charge of operation of the product. Operate the product after carefully reading and sufficiently understanding the instructions. If the product fails to function satisfactorily, non-technical personnel should under no circumstances touch the internal system. Please contact where the product was purchased from.

Use of this product is unlikely to cause physical injuries or damages to property. However, where special attention is required this is indicated by a thick line, the word "IMPORTANT" and its sign in this manual.



**IMPORTANT**

Indicates that mishandling the product by disregarding this display can cause the product's intrinsic performance not to be obtained, resulting in malfunctioning.

SEGA ENTERPRISES, INC. (U.S.A.)/CUSTOMER SERVICE  
45133 Industrial Drive, Fremont, California 94538, U.S.A.  
Phone : (415) 701-6580  
Fax : (415) 701-6594

## DEFINITION OF LOCATION MAINTENANCE MAN AND SERVICEMAN



Non-technical personnel who do not have technical knowledge and expertise should refrain from performing such work that this manual requires the location's maintenance man or a serviceman to carry out, or work which is not explained in this manual. Failing to comply with this instruction can cause a severe accident such as electric shock.

Ensure that parts replacement, servicing & inspections, and troubleshooting are performed by the location's maintenance man or the serviceman. It is instructed herein that particularly hazardous work should be performed by the serviceman who has technical expertise and knowledge.

The location's maintenance man and serviceman are herein defined as follows:

### **"Location's Maintenance Man" :**

Those who have experience in the maintenance of amusement equipment and vending machines, etc., and also participate in the servicing and control of the equipment through such routine work as equipment assembly and installation, servicing and inspections, replacement of units and consumables, etc. within the Amusement Facilities and or locations under the management of the Owner and Owner's Operators of the product.

### **Activities of Location's Maintenance Man :**

Assembly & installation, servicing & inspections, and replacement of units & consumables as regards amusement equipment, vending machines, etc.

### **Serviceman :**

Those who participate in the designing, manufacturing, inspections and maintenance service of the equipment at an amusement equipment manufacturer.

Those who have technical expertise equivalent to that of technical high school graduates as regards electricity, electronics and or mechanical engineering, and daily take part in the servicing & control and repair of amusement equipment.

### **Serviceman's Activities :**

Assembly & installation and repair & adjustments of electrical, electronic and mechanical parts of amusement equipment and vending machines.

**LISTED**



**5K92**

**AMUSEMENT MACHINE**



# 1. HANDLING PRECAUTIONS

When installing or inspecting the machine, be very careful of the following points and pay attention to ensure that the player can enjoy the game safely.

Non-compliance with the following points or inappropriate handling running counter to the cautionary matters herein stated can cause personal injury or damage to the machine.



**WARNING!**

- Before performing work, be sure to turn power off. Performing the work without turning power off can cause an electric shock or short circuit. In the case work should be performed in the status of power on, this manual always states to that effect.
- To avoid electric shock or short circuit, do not plug in or unplug quickly.
- To avoid electric shock, do not plug in or unplug with a wet hand.
- Do not expose Power Cords and Earth Wires on the surface, (floor, passage, etc.). If exposed, the Power Cords and Earth Wires are susceptible to damage. Damaged cords and wires can cause electric shock or short circuit.
- To avoid causing a fire or electric shock, do not put things on or damage Power Cords.
- When or after installing the product, do not unnecessarily pull the power cord. If damaged, the power cord can cause a fire or electric shock.
- In case the power cord is damaged, ask for replacement through where the product was purchased from or the office herein stated. Using the cord as is damaged can cause fire, electric shock or leakage.
- Be sure to perform grounding appropriately. Inappropriate grounding can cause an electric shock.
- Be sure to use fuses meeting specified rating. Using fuses exceeding the specified rating can cause a fire or electric shock.
- Completely make connector connections for IC BD and others. Insufficient insertion can cause an electric shock.
- To avoid causing a fire or electric shock, do not make Specification changes by removing, converting and making additions unless otherwise designated by SEGA.
- Be sure to perform periodic maintenance inspections herein stated.



**IMPORTANT!**

- For the IC board circuit inspections, only the logic tester is allowed. The use of a multiple-purpose tester is not permitted, so be careful in this regard.
- When cleaning the CRT surfaces, use a soft, dry cloth. Do not apply chemicals such as thinner, benzine, etc.
- The electronic parts on the IC Board could be damaged due to human body's static electricity. Before performing IC Board related work, be sure to discharge physically accumulated statics by touching grounded metallic surfaces, etc.

## 2. PRECAUTIONS CONCERNING INSTALLATION

### LOCATION



WARNING!

This product is an indoor game machine. Do not install it outside. Even indoors, avoid installing in places mentioned below so as not to cause a fire, electric shock, injury and or malfunctioning.

- Places subject to rain or water leakage, or places subject to high humidity in the proximity of an indoor swimming pool and or shower, etc.
- Places subject to direct sunlight, or places subject to high temperatures in the proximity of heating units, etc.
- Places filled with inflammable gas or vicinity of highly inflammable/volatile chemicals or hazardous matter.
- Dusty places.
- Sloped surfaces.
- Places subject to any type of violent impact.
- Vicinity of anti-disaster facilities such as fire exits and fire extinguishers.
- The operating (ambient) temperature range is from 5°C to 40°C.  
Only in the case a projector is employed, the temperature range is from 5°C to 30°C.

### LIMITATIONS OF USAGE REQUIREMENTS



WARNING!

- Be sure to check the Electrical Specifications.  
Ensure that this product is compatible with the location's power supply, voltage and frequency requirements.  
A plate describing Electrical Specifications is attached to the product.  
Non-compliance with the Electric Specifications can cause a fire and electric shock.
- This product requires the Breaker and Earth Mechanisms as part of the location facilities. Using them in a manner not independent can cause a fire and electric shock.
- Ensure that the indoor wiring for the power supply is rated at 15A or higher (AC single phase 100 ~ 120V area), and 7A or higher (AC 220 ~ 240V area).  
Non-compliance with the Electrical Specifications can cause a fire and electric shock.
- Be sure to independently use the power supply equipped with the Earth Leakage Breaker. Using a power supply without the Earth Leakage Breaker can cause an outbreak of fire when earth leakage occurs.
- Putting many loads on one electrical outlet can cause generation of heat and a fire resulting from overload.
- When using an extension cord, ensure that the cord is rated at 15A or higher (AC 100 ~ 120V area) and 7A or higher (AC 220 ~ 240V area). Using a cord rated lower than the specified rating can cause a fire and electric shock.

### Electric current consumption

MAX. 8.70 A (AC 110V 50 Hz)  
MAX. 8.30 A (AC 110V 60 Hz)  
MAX. 7.70 A (AC 120V 60 Hz)  
MAX. 4.50 A (AC 220V 50 Hz)  
MAX. 4.30 A (AC 220V 60 Hz)  
MAX. 4.20 A (AC 230V 50 Hz)  
MAX. 4.00 A (AC 230V 60 Hz)  
MAX. 4.10 A (AC 240V 50 Hz)  
MAX. 3.90 A (AC 240V 60 Hz)  
MAX. 8.30 A (For TAIWAN)



- For transporting the machine into the location's building, the minimum necessary dimensions of the opening (of doors, etc.) are 1.2m(W) and 1.7m(H).
- For the operation of this machine, secure a minimum area of 2.49m (W) x 3.16m (D). For ventilation, provide an approximately 20cm. space between the rear part of the cabinet and the wall.

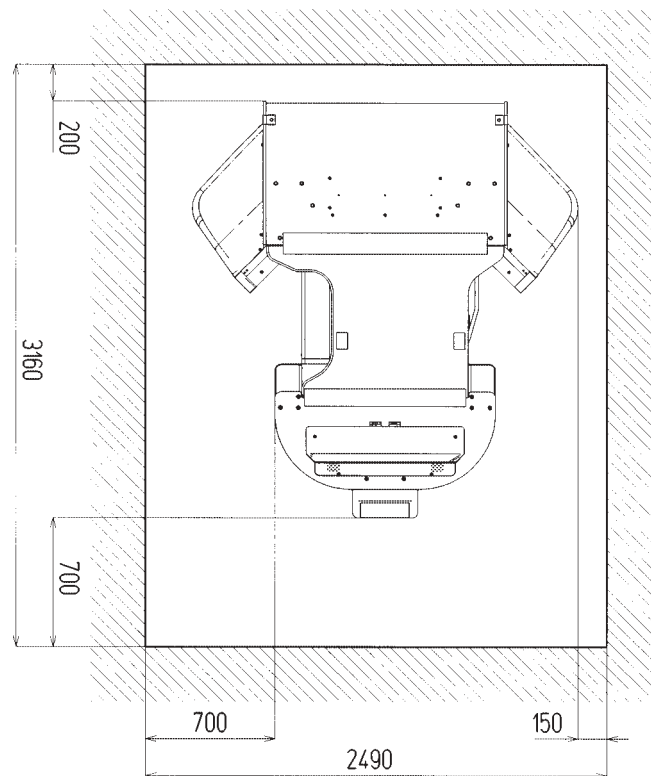

FIG. 2

### 3. OPERATION

#### PRECAUTIONS TO BE HEEDED BEFORE STARTING THE OPERATION

To avoid injury and trouble, be sure to constantly give careful attention to the behavior and manner of the visitors and players.



In order to avoid accidents, check the following before starting the operation:

- Check if all of the adjusters are in contact with the surface. If they are not, the Cabinet can move and cause an accident.

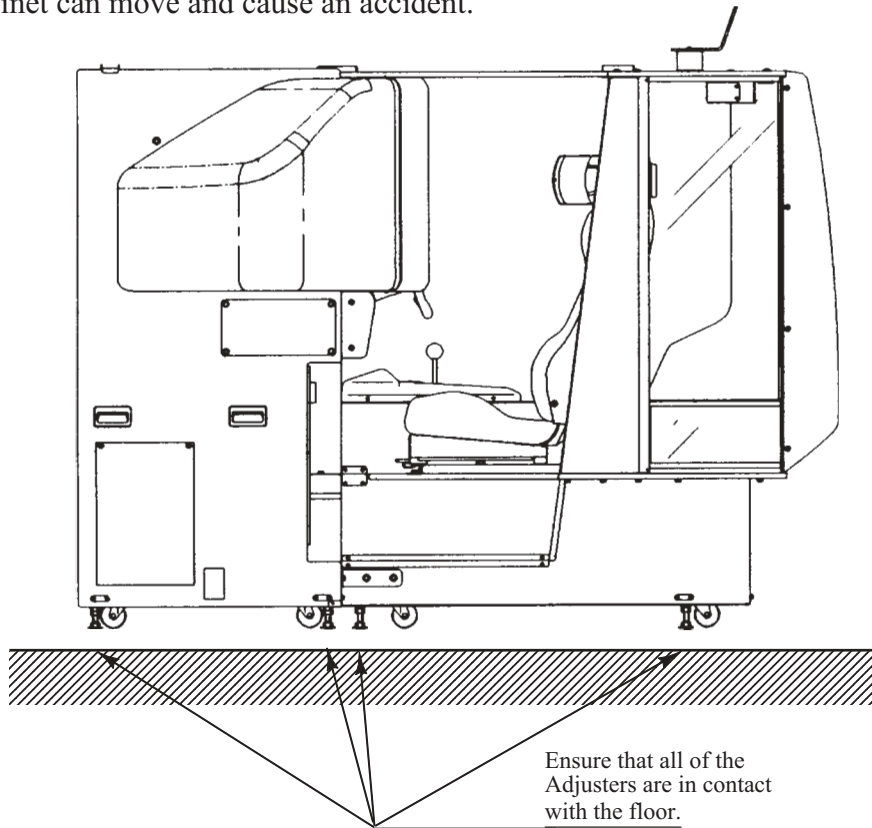

- Do not put any heavy item on this product. Placing any heavy item on the product can cause a falling down accident or parts damage.
- Do not climb on the product. Climbing on the product can cause falling down accidents. To check the top portion of the product, use a step.
- To avoid electric shock, check to see if door & cover parts are damaged or omitted.
- To avoid electric shock, short circuit and or parts damage, do not put the following items on or in the periphery of the product.  
Flower vases, flowerpots, cups, water tanks, cosmetics, and receptacles/containers/vessels containing chemicals and water.



To avoid injury, be sure to provide sufficient space by considering the potentially crowded situation at the installation location. Insufficient installation space can cause the customers to come into contact with or hit the others and result in injury or trouble.

PRECAUTIONS TO BE HEHEDED DURING OPERATION (PAYING ATTENTION TO CUSTOMERS)

To avoid injury and trouble, be sure to constantly give careful attention to the behavior and manner of the visitors and players.



WARNING!

- To avoid injury and accidents, those who fall under the following categories are not allowed to play the game.
  - Those who need assistance such as the use of an apparatus when walking.
  - Those who have high blood pressure or a heart problem.
  - Those who have experienced muscle convulsion or loss of consciousness when playing video game, etc.
  - Those who have a trouble in the neck and or spinal cord.
  - Intoxicated persons.
  - Pregnant women or those who are in the likelihood of pregnancy.
  - Persons susceptible to motion sickness.
  - Persons whose act runs counter to the product's warning displays.
- To avoid injury resulting from falling down, and electric shock due to spilled drinks, instruct the player not to place heavy items or drinks on the product.
- To avoid electric shock and short circuit, do not allow customers to put hands and fingers or extraneous matter in the openings of the product or small openings in or around the doors.
- To avoid falling down and injury resulting from falling down, immediately stop the customer's leaning against or climbing on the product, etc.
- To avoid electric shock and short circuit, do not allow the customers to unplug the power plug without a justifiable reason.
- To avoid a fire due to a cigarette stub, caution the customers so as not to put dust on the Seat rear.
- Caution the customers so as not to put dust on the outlet for driving records. Failure to observe this may cause a fire due to cigarette stubs.
- This product is intended for 1 Player only. Playing the game by 2 or more Players riding on the seat together can cause falling down and collision accidents by striking head, hand, or elbow.



CAUTION!

- Immediately stop such violent acts as hitting and kicking the product. Such violent acts can cause parts damage or falling down, resulting in injury due to fragments and falling down.
- To avoid collision or falling down accident, caution the customers so as not to come in to the Seat rear.
- Instruct the Player to take firm hold of the Steering Wheel when in play. The Steering Wheel is equipped with reaction mechanism. Holding the Steering Wheel lightly while playing the game can cause a contingent accident.
- Instruct the customer, other than the Player, not to touch the operation device when in play. Touching the operation device during play can cause accidents and trouble between customers.
- Instruct the Player to adjust the seat before playing the game. Playing the game in a forcible posture can cause a contingent accident.
- This product is designed for players taller than 130cm and shorter than 210cm. To avoid accidents, instruct the customers who do not meet the height requirements to refrain from playing the game.

# 4. NAME OF PARTS

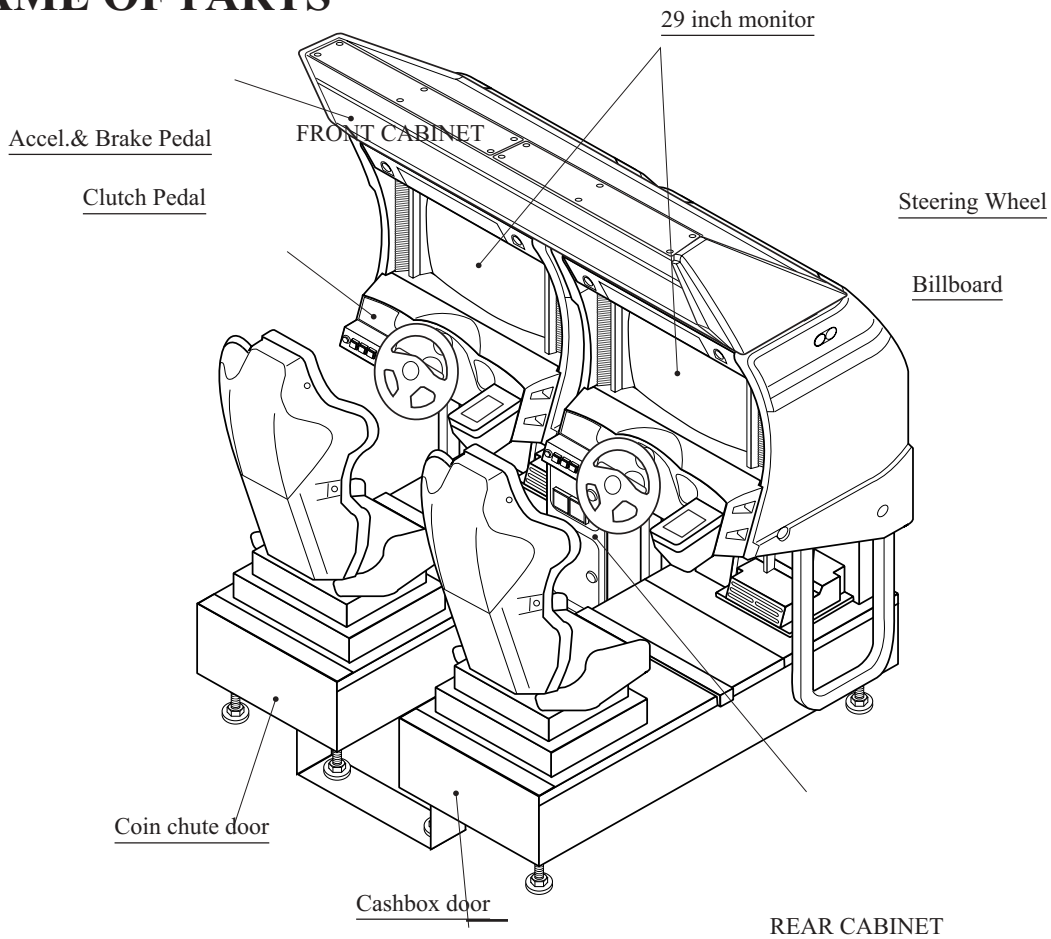

FIG. 4 a OVERVIEW

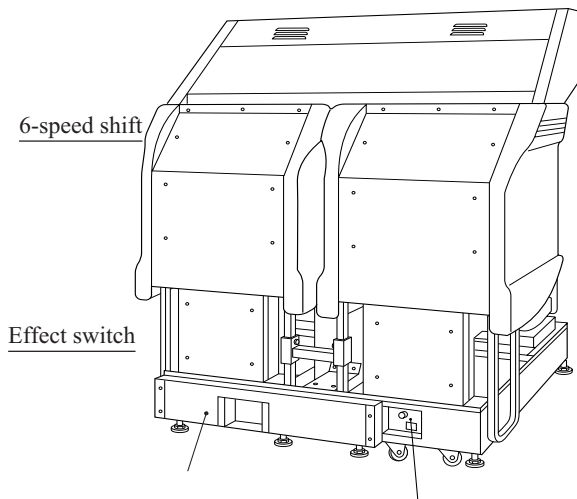

FIG. 4 b

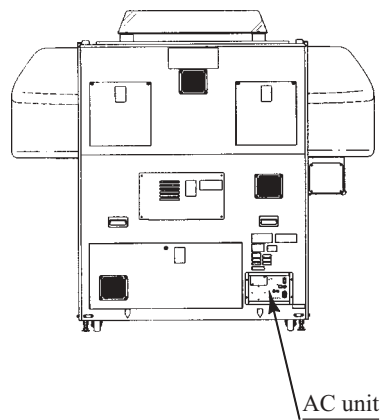

FIG. 4 c REAR VIEW

TABLE 4

	Width	X	Length	X	Height	Weight
FRONT CABINET	2,080 mm	X	780 mm	X	1,649 mm	401 kg
REAR CABINET	1,190 mm	X	1,480 mm	X	1,649 mm	187 kg
When assembled	2,080 mm	X	2,260 mm	X	1,833 mm	598 kg

## 5. ACCESSORIES

When transporting the machine, make sure that the following parts are supplied.

The printer is available in this product as an optional. The printer prints Player's game results on the paper exclusively used for this product. Contact where you purchased the product from and mention the following Kit No. for an order. Detailed installation method is explained in the Kit Manual contained in the Kit.

KIT NO. : XKT-0440-EX1 DESCRIPTION: PRINTER KIT FOR FRI DX EXP

TABLE 5 ACCESSORIES

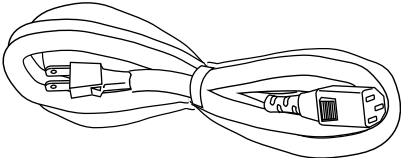
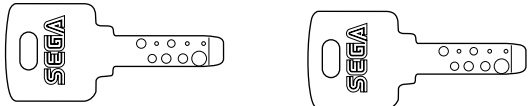
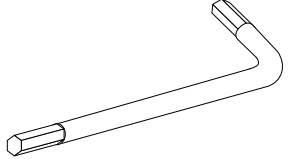
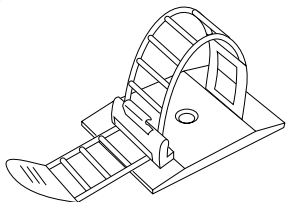
DESCRIPTION	OWNERS MANUAL	SERVICE MANUAL
Part No.( Qty. )	420-6507-01( 1 )	420-6508-01( 1 )
Note		
Figures		
If Part No. has no description, the Number has not been registered or can not be registered. Such a part may not be obtainable even if the customer desires to purchase it. Therefore, ensure that the part is in safekeeping with you.		
AC Cable (Power Cord) 600-6729 (1) AC 110V AREA 600-6695 (1) AC 120V AREA 600-6618 (1) AC 220 ~ 240V AREA Used for installation, see <b>4</b> of Section 6.		KEY MASTER 220-5576 ( 2 ) For opening/closing the doors
		KEY ( 2 ) For the CASHBOX DOOR
		
		TAMPERPROOF†WRENCH M8 540-0009-01 (1) TOOL
		
CORD CLAMP 280-5009-01 (1) Used for securing the power cord. see <b>4</b> of Section 6.		
		



VOL CONT B-5K OHM  
220-5484  
220-5373 (1)  
Spare,  
see Section 9, 11, 12.

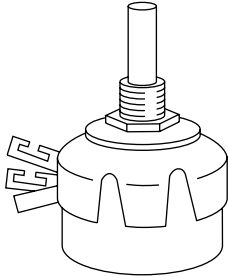

SW MICRO TYPE  
509-5387 (2)  
Spare, see Section 9.

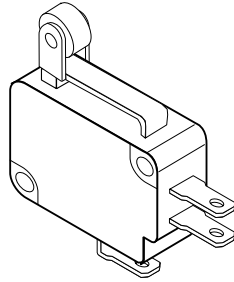

SW MICRO TYPE  
509-5636 (2)  
Spare, see Section 10.

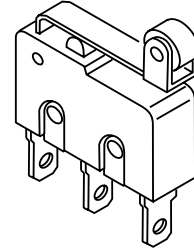

FUSE 6.3A 250W  
514-5086-6300 (1)  
Spare, see Section 17.

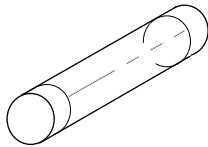

CARTON BOX  
601-10577 (1)  
Used for transporting the  
Game Board.  
Refer to Next Page.

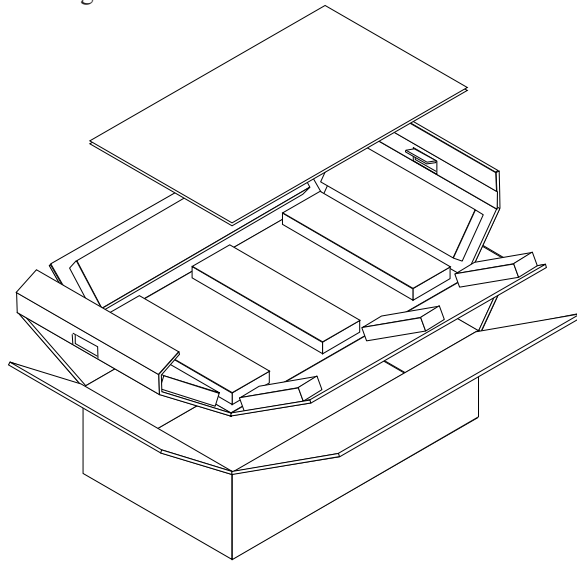

TAMPERPROOF†SCREW  
008-B00830-0B (2)  
Used for installing  
BILLBOARD.  
see 2 of Section 6.

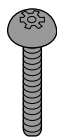

## HOW TO USE THE CARTON BOX



When requesting for the replacement/repair of this product's Game Board (NAOMI BOARD), follow the instructions below. Transporting the Game Board in an undesignated status is unacceptable. An erroneous handling can cause parts damage.

- Put the Game Board in the Carton Box together with the Shield Case. Do not unnecessarily disassemble nor remove parts.
- By paying careful attention to the direction shown by the following Figure, put the Shield Case in the Carton Box.

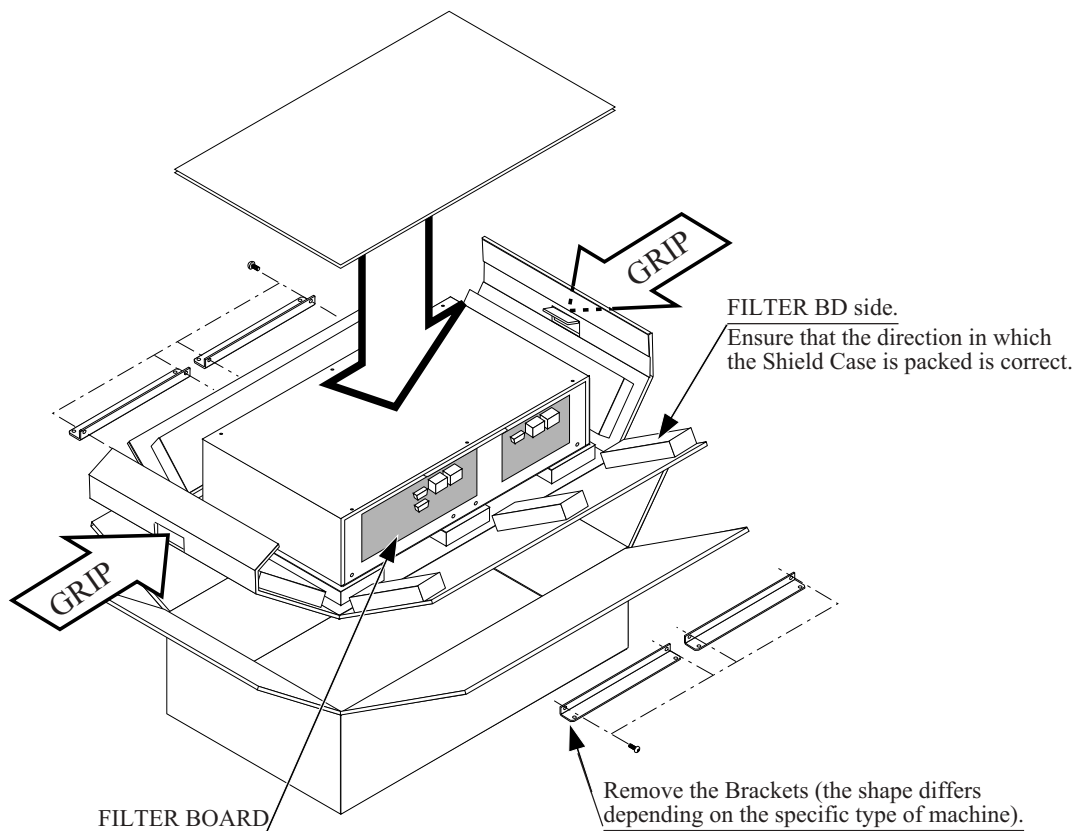

Enfold the Shield Case with the packing material shown, and put it in the carton box. Positioning the Shield Case upside down or packing in the manner different from what is shown in this Figure can cause the Game Board and other parts to be damaged.

## 6. ASSEMBLING AND INSTALLATION



WARNING!

- Perform assembly work by following the procedure herein stated. Failing to comply with the instructions can cause electric shock hazard.
- Perform assembling as per this manual. Since this is a complex machine, erroneous assembling can cause an electric shock, machine damage and or not functioning as per specified performance.
- When assembling, be sure to use plural persons. Depending on the assembly work, there are some cases in which working by one person alone can cause personal injury or parts damage.
- Ensure that connectors are accurately connected. Incomplete connections can cause electric shock hazard.
- Be careful so as not to damage wirings. Damaged wiring can cause electric shock and short circuit hazards.
- In the case the cabinet is separated into the front and rear portions, do not push the upper rear part of the front cabinet. Failure to observe this causes the front cabinet to fall down towards the monitor side and result in accidents and injury to persons. When moving the front cabinet in the above case, be sure to push it from side directions and move it by 2 or more persons for safety.
- This work should be performed by the Location's Maintenance Man or Serviceman. Performing work by non-technical personnel can cause a severe accident such as electric shock. Failing to comply with this instruction can cause a severe accident such as electric shock to the player during operation.
- Provide sufficient space so that assembling can be performed. Performing work in places with narrow space or low ceiling may cause an accident and assembly work to be difficult.



CAUTION!

When handling plastic parts, use care. Do not give a shock or apply excessive load to the fluorescent lamps and plastic parts. Failure to observe this can cause parts damage, resulting in injury due to fragments, cracks and broken pieces.

When carrying out the assembling and installation, follow the following 6-item sequence.

- 1** ASSEMBLING THE CABINET
- 2** INSTALLING THE CENTER ROOF AND THE BILLBOARD
- 3** SECURING IN PLACE (ADJUSTER ADJUSTMENT)
- 4** POWER SUPPLY CONNECTION
- 5** TURNING POWER ON
- 6** ASSEMBLING CHECK

The master key (accessories) in addition to the tools such as a Phillips type screwdriver, wrench for M16 hexagon bolt, socket wrench, Ratchet Handle for M6, M8 hexagon bolt, Tamperproof†wrench (accessories) are required for the assembly work.

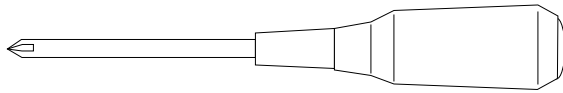

Phillips type screwdriver

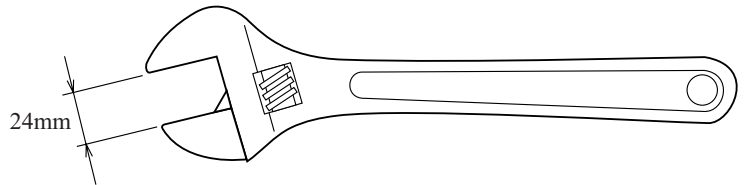

WRENCH (for M16 hexagon bolt)

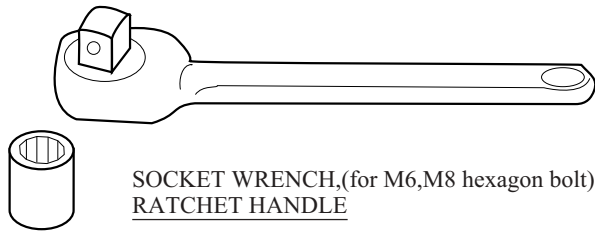

SOCKET WRENCH,(for M6,M8 hexagon bolt)  
RATCHET HANDLE

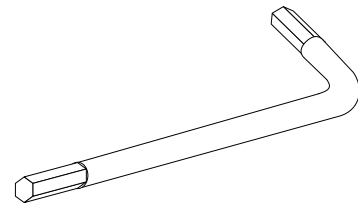

TAMPERPROOF†WRENCH

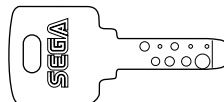

KEY MASTER

**1**

**ASSEMBLING THE CABINET**

- ① Install the Joint Bracket L and 2 Joint Bracket R to the both sides of Front Cabinet, and 2 Joint Pipes to the inside. At this time, temporarily install the Joint Brackets L and R.

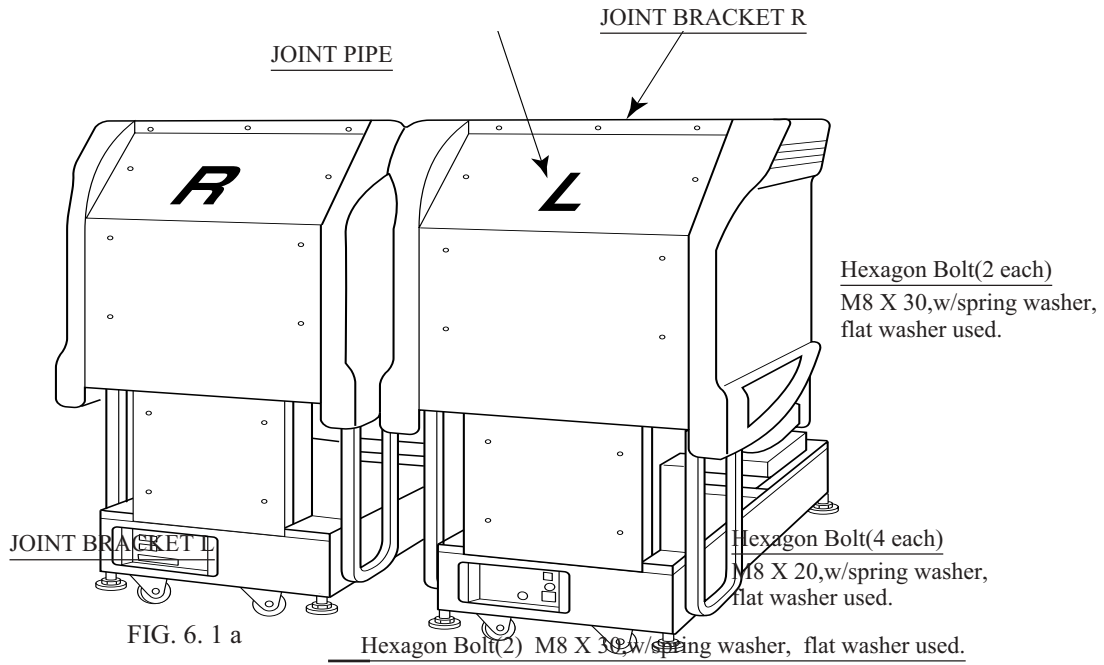

- ② Connect the wiring from the Front Cabinet to the Rear Cabinet.

Connect the Earth.

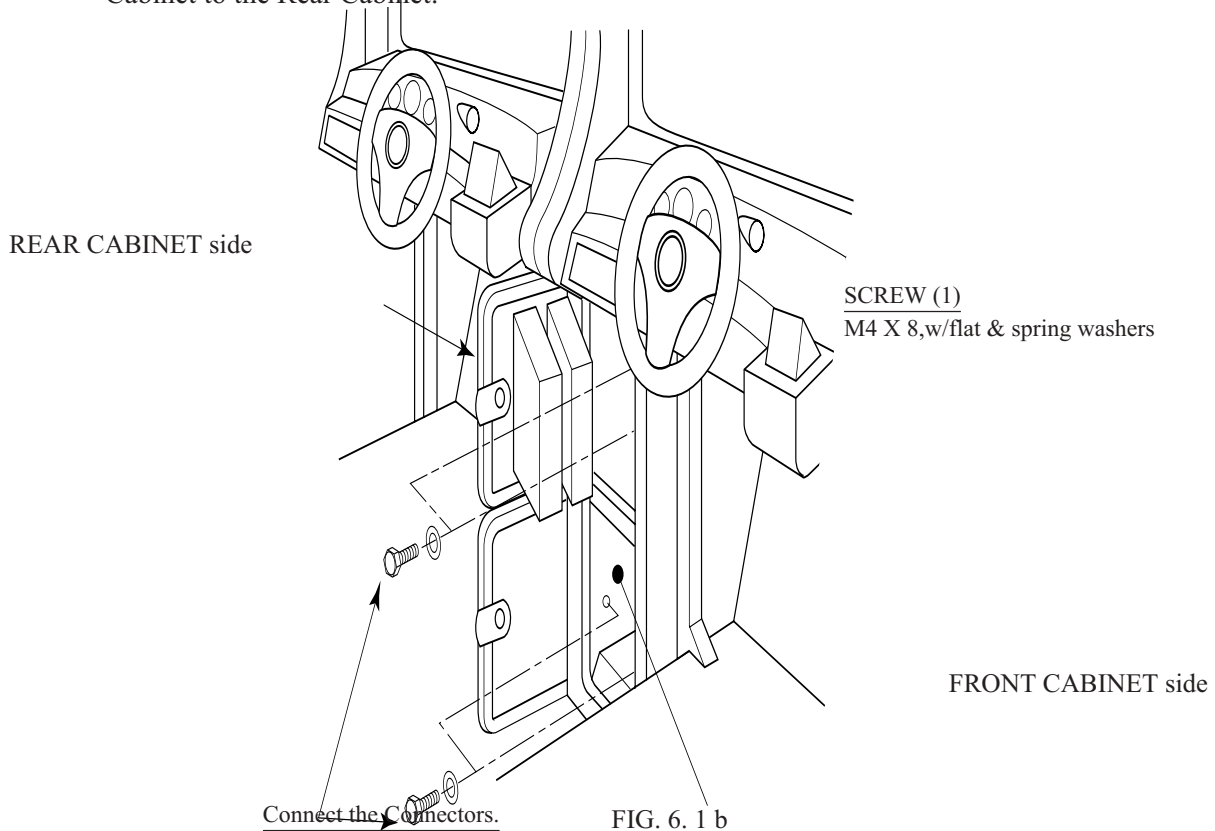

- ③ Insert the Front Cabinet's Joint pipes into the Rear Cabinet's square holes to fit both cabinets tight. Be sure to perform this work by 2 or more workers. Also, be careful so as not to pinch the wiring.
- ④ Secure the joint portion of the Cabinets with 6 Hexagon Bolts. Firmly secure the Joint Brackets L&R, respectively.
- ⑤ By using Joint Plate Center, secure the joint portion of the Cabinets with 4 Truss screws and Hexagon Bolts.

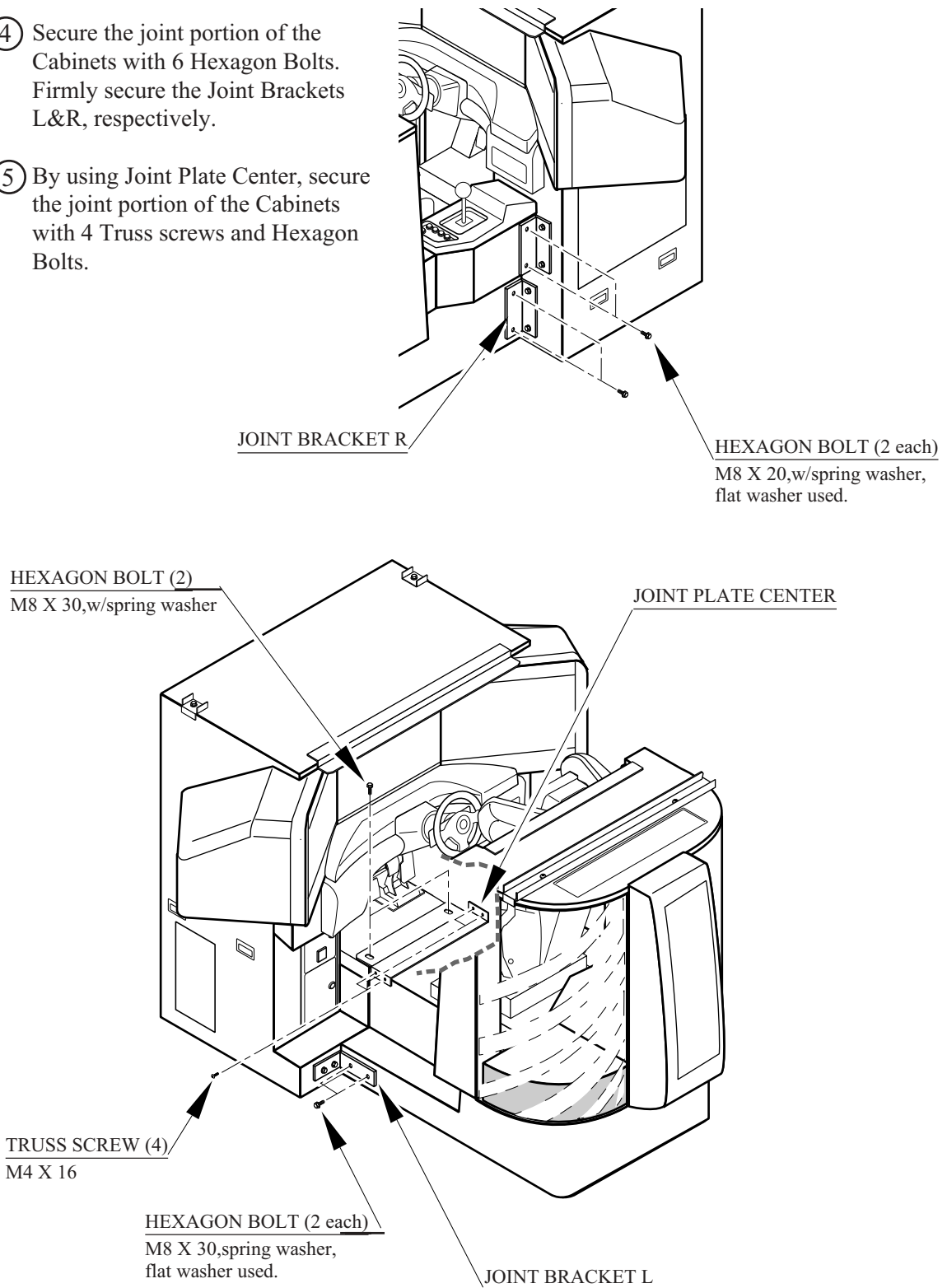

FIG. 6. 1 c

## 2

### INSTALLING THE CENTER ROOF AND THE BILLBOARD

- ① Put the Center Roof on its installation position.
- ② Put each of Roof Nut Plates F & R on to the fixed portion of the Center Roof front and rear and secure with 3 Truss screws for each.
- ③ Remove the Shipping Bracket Rear from the Rear Cabinet's ceiling. Remove the 2 pairs of Tamperproof screws and Hexagon Bolts.
- ④ Secure the Billboard with the 2 Tamperproof screws (separately packed) and the 2 flat washers which previously secured the Shipping Bracket Rear.

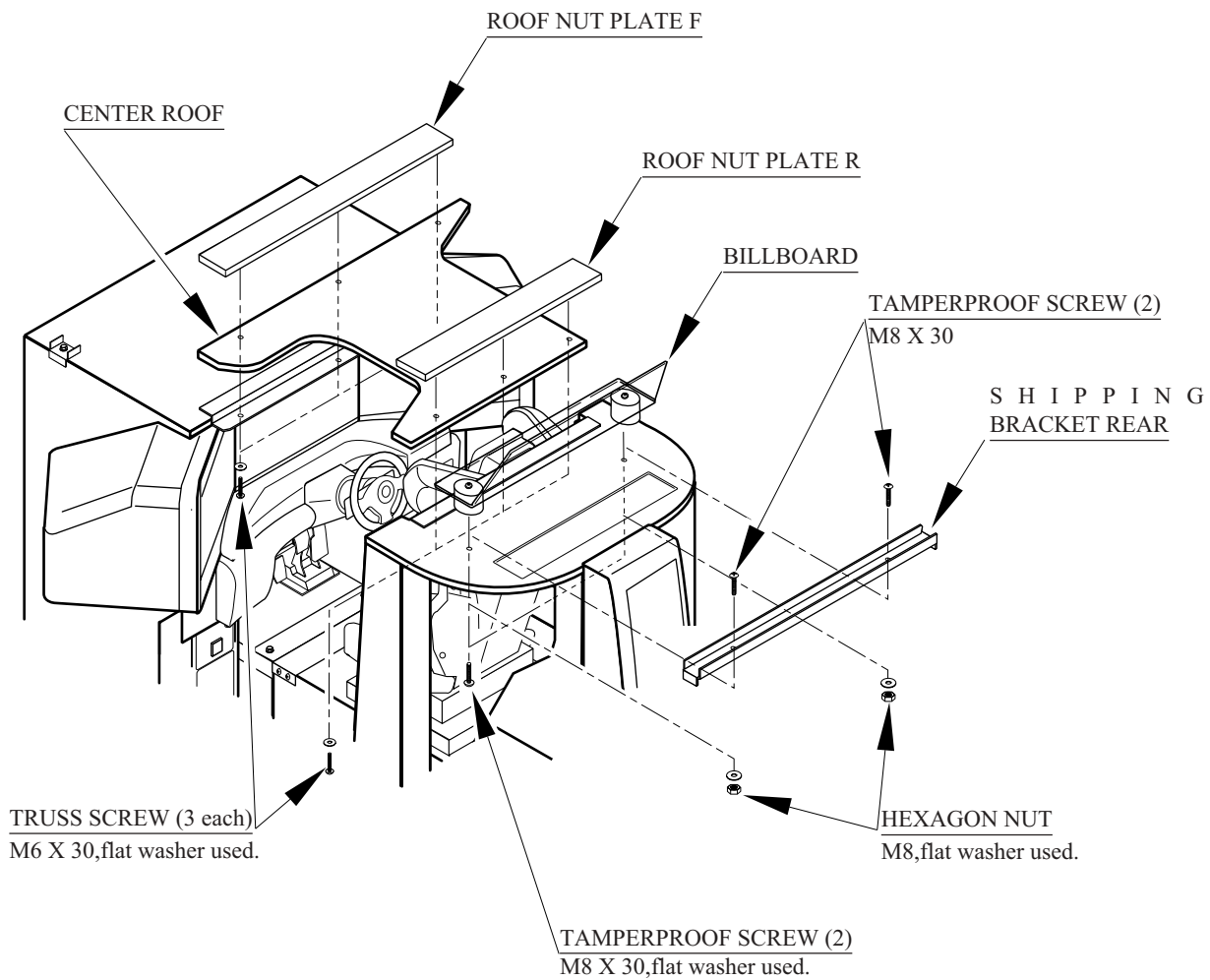

FIG. 6. 2



# 3

## SECURING IN PLACE (ADJUSTER ADJUSTMENT)



Make sure that all of the adjusters are in contact with the floor. If they are not, the cabinet can move and cause an accident.

This product has 8 casters (4 for Front Cabinet, 4 for Rear Cabinet) and 8 Adjusters (4 for Front Cabinet, 4 for Rear Cabinet). (FIG. 6. 3a) When the installation position is determined, cause the adjusters to come into contact with the floor directly, make adjustments in a manner so that the casters will be raised approximately 5mm. from the floor and make sure that the machine position is level.

- ① Transport the product to the installation position. Be sure to provide adequate space allowing the player to get on and off.
- ② Have all of the Adjusters make contact with the floor. Adjust the Adjuster's height by using a wrench so that the machine position is kept level.
- ③ After making adjustment, fasten the Adjuster Nut upward and secure the height of Adjuster (FIG. 6. 3 b).

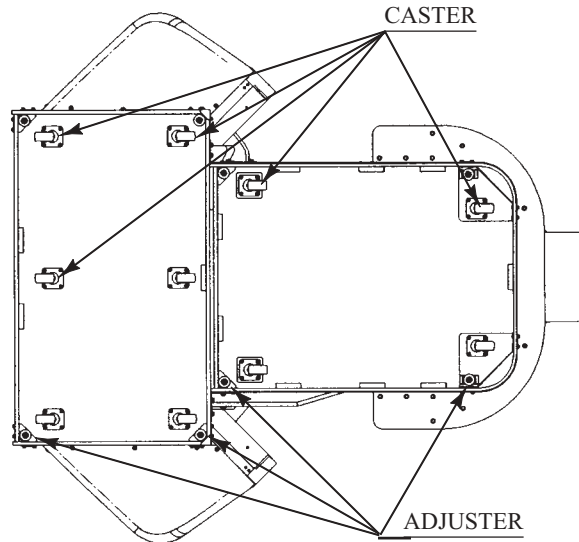

FIG. 6. 3 a BOTTOM VIEW

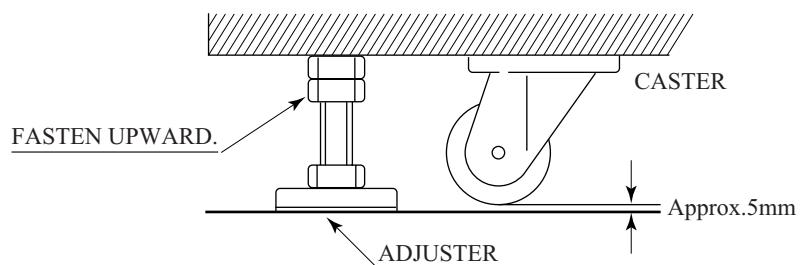
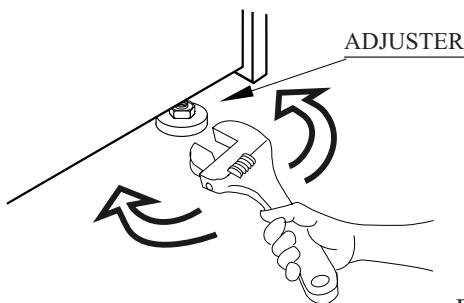

FIG. 6. 3 b ADJUSTER

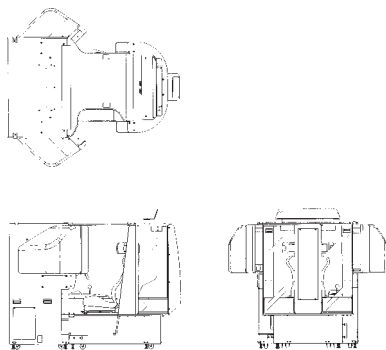

FIG. 6. 3 c  
Refer to this Fig. (Scale:1/100)  
for the layout of the place of  
installation.

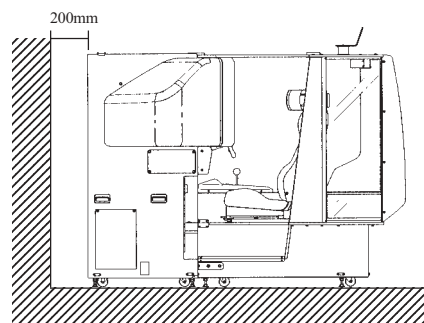

FIG. 6. 3 d  
Be sure to provide space as shown between  
the Air Vent and the wall surface.



## POWER SUPPLY, AND EARTH CONNECTION



- Be sure to independently use the power supply socket outlet equipped with an Earth Leakage Breaker. Using a power supply without an Earth Leakage Breaker can cause a fire when electric leakage occurs.
- Ensure that the "accurately grounded indoor earth terminal" and the earth wire cable are available (except in the case where a power cord plug with earth is used). This product is equipped with the earth terminal. Connect the earth terminal and the indoor earth terminal with the prepared cable. If the grounding work is not performed appropriately, customers can be subjected to an electric shock, and the product's functioning may not be stable.
- Ensure that the power cord and earth wire are not exposed on the surface (passage, etc.). If exposed, they can be caught and are susceptible to damage. If damaged, the cord and wire can cause electric shock and short circuit accidents. Ensure that the wiring position is not in the customer's passage way or the wiring has protective covering.
- After wiring power cord on the floor, be sure to protect the power cord. Exposed power cord is susceptible to damage and causes an electric shock accident.

The AC Unit is mounted on the rear of the machine. The AC Unit has Main SW, Circuit Protector and the Inlet which connects the Power Cord.

- ① Ensure that the Main SW is OFF.

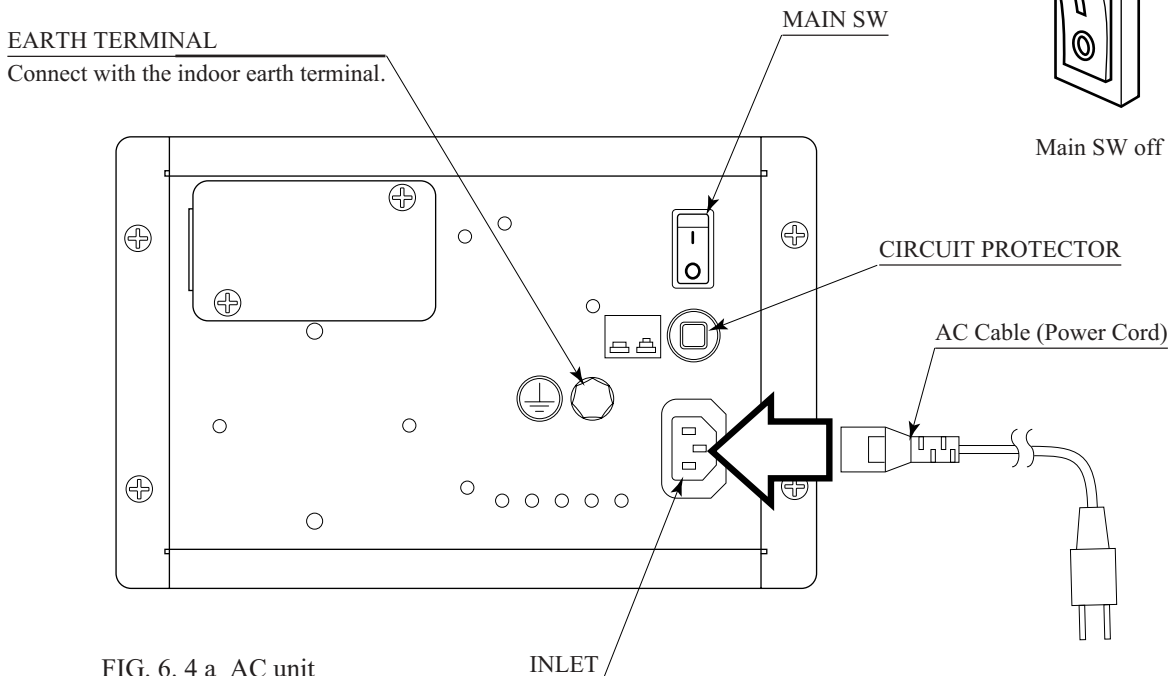
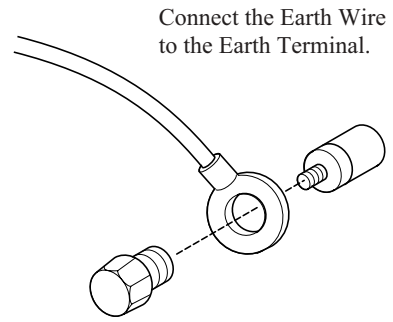

FIG. 6. 4 a AC unit

INLET

- ② Connect one end of the earth wire to the AC Unit earth terminal, and the other end to the indoor earth terminal. The AC Unit earth terminal has a Bolt and Nut combination. Take off the Nut, pass the end of earth wire through the Bolt, and fasten the Nut.

Note that the Earth Wire is incorporated in the Power Cord for the Areas of AC 120V (USA) and AC 220Å'240V, and therefore, this procedure is not necessary.



Connect the Earth Wire to the Earth Terminal.

FIG. 6. 4 b Earth Wire Connection

- ③ Firmly insert the power plug into the socket outlet. Insert the opposite side of Power Cord plug to the AC Unit's connector ("INLET").
- ④ Perform wiring for the Power Cord and Earth Wire. Install protective covering for the Power Cord and Earth Wire.

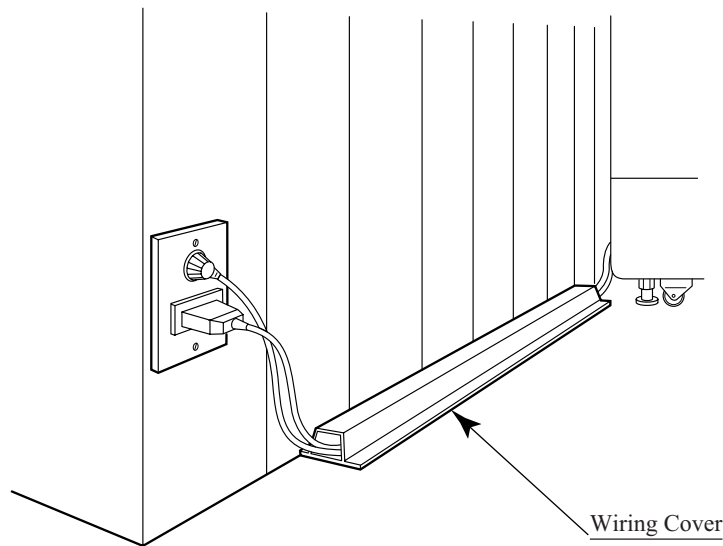
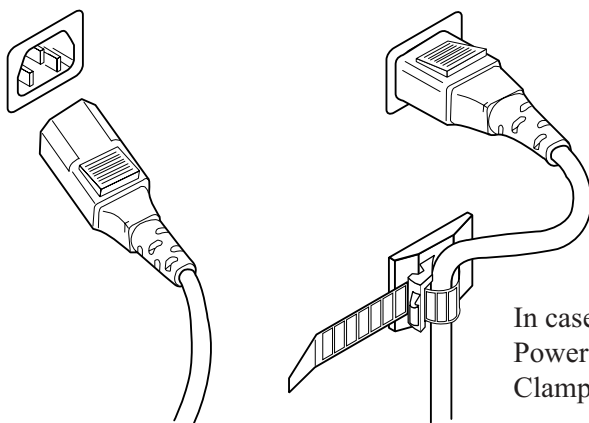

FIG. 6. 4 c Connecting Power Cord and Earth Wire



In case the Power Plug is apt to come out of place, secure the Power Cord to the periphery of the AC Unit with the Cord Clamp (an accessory).

#### HOW TO USE THE CORD CLAMP

# 5

## TURNING POWER ON

Turn the Main SW of AC Unit ON to turn power on. When the power is turned on, the fluorescent lamps of the left & right of Seat in the Rear cabinet, the back, and the inside the Billboard light up. The screen displays the starting of Naomi System and then proceeds to ADVERTISE mode. During this time, the machine automatically performs Power On check. Do not touch the machine until Power On check is finished and ADVERTISE mode is displayed on the screen. In the Power On check, the steering wheel turns left and right, then returns to the centering position and stops. In this check, the values of V.R. inside the control panel are corrected. Until the check is finished (the steering wheel stops automatically), do not touch the steering wheel or play the game. If you do, the steering wheel reaction during the game (reaction at the time of a course-out or crashing) can not be obtained correctly. In case of an abnormal reaction during the game, turn the power on again from the beginning and complete the power-on check. In this product, once the power is turned off, the data of inserted coins less than one credit and BONUS ADDER is cleared. As the exclusively used paper is not supplied to the Printer at the time of shipment, the message "Printer unavailable" is displayed on the Advertise screen and the 2 red Lamps of the Rear Cabinet back side light up.

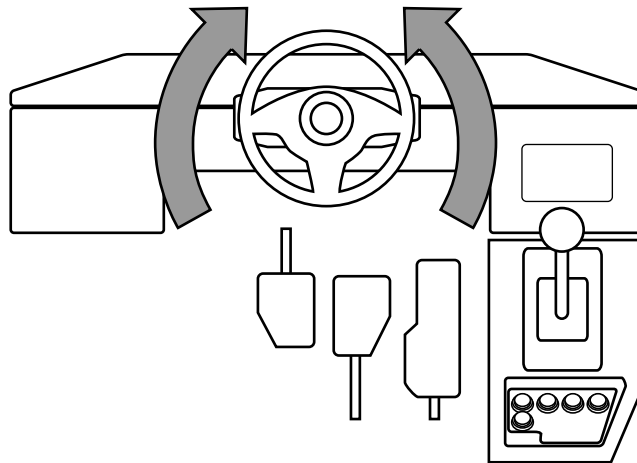

FIG. 6. 5



## ASSEMBLING CHECK

In the TEST mode, ascertain that the assembly has been made correctly, IC BD. is satisfactory, and the screen adjustment is appropriate. For details, refer to the SERVICE MANUAL. In the test mode, perform the following test:

- MEMORY TEST  
The on-board memory is tested automatically.
- CRT TEST  
The screen on which the monitor is adjusted is displayed.
- INPUT TEST  
Each switch and V.R. are tested.
- OUTPUT TEST  
The lamp, motor, etc. are tested.
- SOUND TEST  
The sound related BD and wiring connections are tested. Be sure to check if the sound is satisfactorily emitted from each speaker and the sound volume is appropriate.

Perform the above inspections also at the time of monthly inspection.

## 7. PRINTER (OPTIONAL)

Refer to this section only when the Printer (optional) is attached.



- Be sure to turn off power unless otherwise specified before performing work. Performing work on the energized machine can cause hands or fingers to be pinched in or injured due to the machine's sudden move.
- Do not touch undesignated places. Failure to observe this may cause a burn due to the Head's high temperature when printing.
- When performing work that uses the cutter, be very careful so as not to cut hands or fingers.



- Be sure to use the exclusively used paper and a Cleaning Pen. Using unspecified parts can cause malfunctioning and/or a damage to parts.
- Be sure to use the new roll paper unwrapped immediately before the use. Using the roll paper previously unwrapped and left for a while can cause malfunctioning due to deterioration resulted from humidity.
- When setting the paper with the power on, if the paper volume is small, the Printer might not accept the set roll paper. In that case, follow the "SETTING THE PAPER WITH THE POWER OFF" procedures to set the paper.

When the Printer is malfunctioning, the 2 Error Lamps attached to the Rear Cabinet back side flash or light up. The Lamps flash when the paper is exhausted and light up when the trouble is other than the running out of paper.

When placing an order, contact where you purchased the product or the Printer Kit from in stating the following part number and the description.

The following set (Part Number: 601-10735-01) consists of 4 rolls of exclusively used paper and a Cleaning Pen.

PART NUMBER: 601-10735-01 DESCRIPTION: PAPER FOR F355 ENG

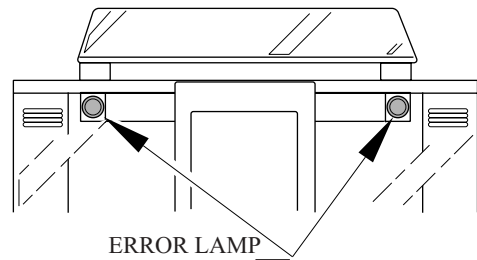

FIG. 7

### 7 - 1 OPERATION WITH THE PRINTER ATTACHED

The Printer which prints Player's Driving Data and the GAME BOARD do not keep the data to be printed. When "PRINTING CAN NOT BE DONE" is displayed or the PRINTER is set to OFF in the Test mode, printing can not be done as the product does not have such system as printing out the data at a later operation. Therefore, as for the printing, instruct the Player to pay attention to the following.

- Although YES is selected to the "PRINT OUT?" question displayed on the monitor, printing can not be done if a credit worth coin is not inserted within the time limit. Such credit (coin) as inserted after the time limit is regarded as a game play credit.
- If the Printer malfunctions such as a paper jam occurred during printing, the printing for the Driving Data can not be done as neither the Printer nor the ROMs on the GAME BOARD keeps the data.
- When "PRINTING CAN NOT BE DONE" is displayed or the PRINTER is set to OFF in the Test mode, printing can not be done as the product does not have such system as printing out the data at a later execution.

## DIP SW SETTING

The Printer has 2 DIP Switches. To avoid malfunctioning, use the Switches as adjusted at the time of shipment.

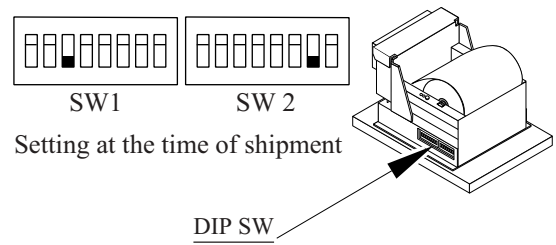

FIG. 7. 1

## 7-2 SETTING THE ROLL PAPER

The 2 red Lamps at the Rear Cabinet back side flash indicating the PAPER END Error under normal operation. Prepare the new Roll Paper exclusively used for the product and the Master Key. To set the Roll Paper, perform Printer's initialization to remove the cause of the error. Turn off power or enter into the Test Mode to perform the initialization. Explanations for setting the Roll Paper in cases of power on and off are given as follows. Further, when the Roll Paper is set after the Printer Kit is installed, performing work with the power off is necessary as the power is turned off when installing the Kit. The Roll Paper has Marks indicating position in order to print and cut properly. The Mark indicating the end of paper appears at the end of Roll Paper. The Printer's Sensor detects the Mark and interprets it as the end of Roll Paper. At the beginning of Cabinet's installation, the red Lamps light up as the Mark indicating the end of Paper is not detected.

## SETTING THE PAPER WITH THE POWER ON

- ① Enter into the TEST Mode and have PRINTER TEST screen displayed on the monitor. "ERROR!!" next to the MESSAGE and "PAPER END" next to the WARNING are displayed on the monitor.

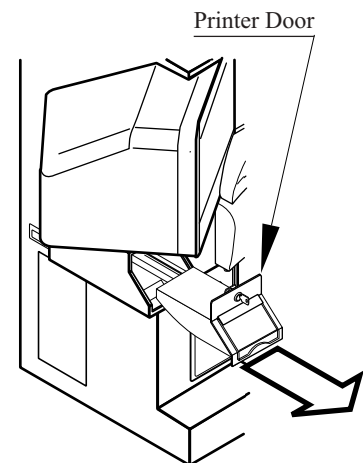
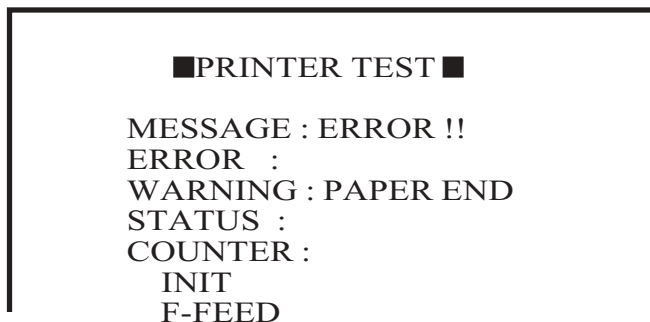

FIG. 7. 2 a

- ② Unlock with the Master Key and remove the Printer Door.
- ③ Draw the ASSY Printer toward you.

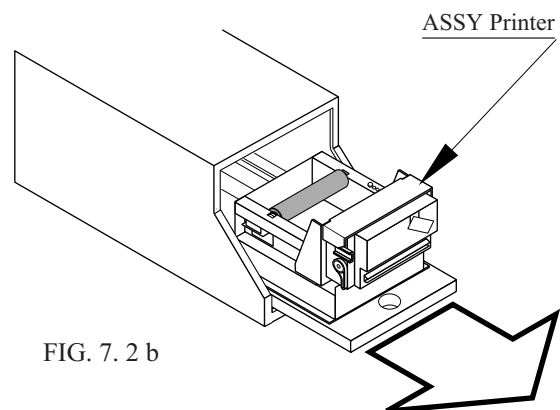

FIG. 7. 2 b



- ④ Pull up the Head Up Lever.
- ⑤ Take out the roll shaft from the Printer.
- ⑥ Pass the shaft through the core of the new Roll Paper.
- ⑦ Install the roll shaft in which the paper is inserted into the unit. Make sure to put the Roll Paper on to the correct position.

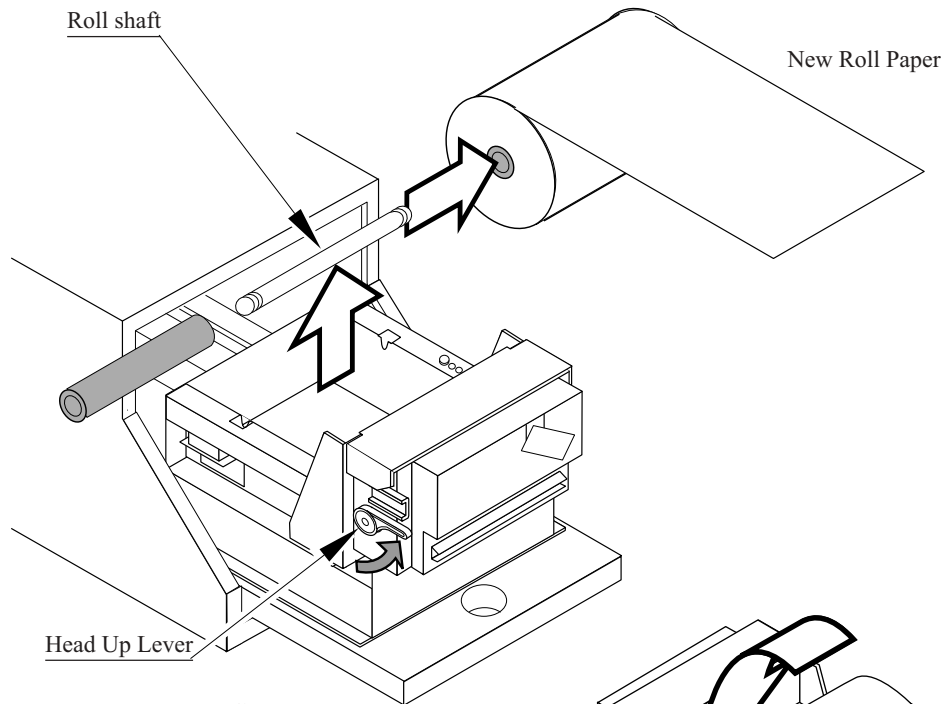

FIG. 7.2 c

- ⑧ Insert the paper tip in to the roll paper insertion slot. Feed the Roll Paper tip through the exit slot straight by hand. At this time, if the Paper tip comes out in excess of the exit slot, Printer performs automatic feeding and cuts the Paper after feeding about one page long.
- ⑨ Push down the Head Up Lever.

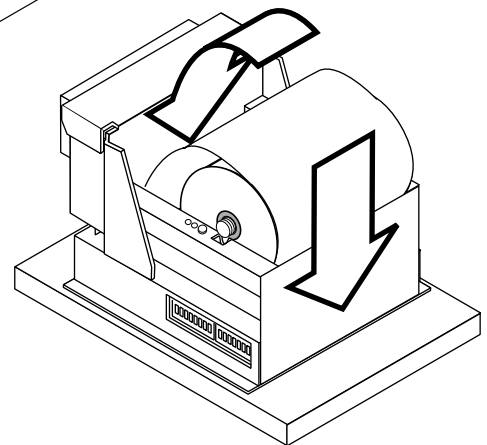

FIG. 7.2 d

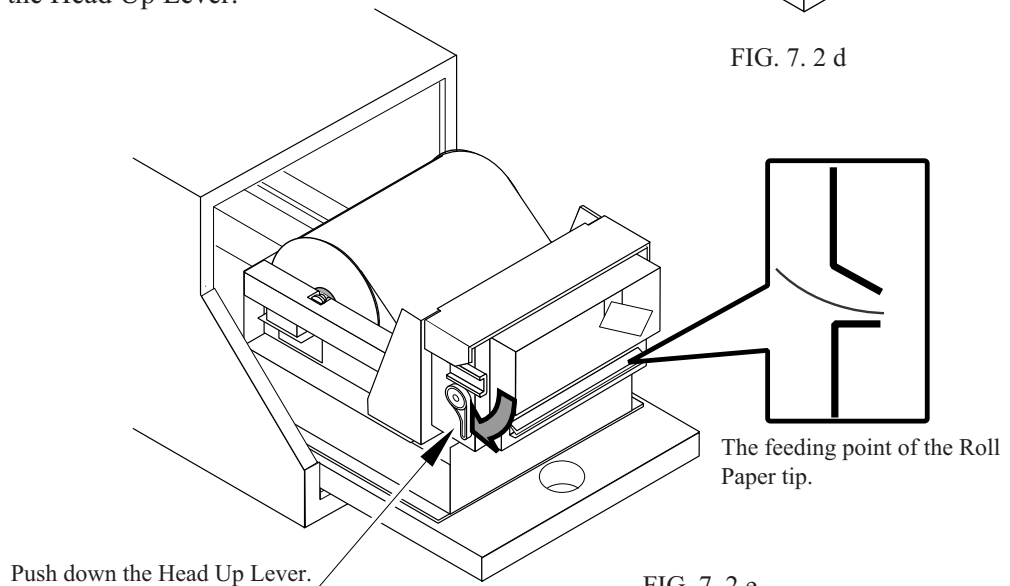

FIG. 7.2 e

- ⑩ Select and execute the INIT in the PRINTER TEST. The "PRINTER INIT!!" message flashes next to "MESSAGE" on the monitor and then goes off. The Printer's initialization is finished.
- ⑪ Select and execute the "POSITION SET." "NOW PRINTING" message is displayed next to the "MESSAGE" on the monitor and then goes off. The Printer starts automatic feeding of the paper (AUTO LOADING) and then cuts the paper automatically. If the Paper tip position is appropriate, the automatic feeding's movement is slight and the paper cutting may not be done. Before executing the POSITION SET, the paper position can be adjusted by executing F-FEED or B-FEED in the PRINTER TEST mode.

■PRINTER TEST ■

MESSAGE : PRINTER INIT!  
 ERROR :  
 WARNING :  
 STATUS :  
 COUNTER :  
 -> INIT  
 F-FEED  
 B-FEED  
 POSITION SET

■PRINTER TEST ■

MESSAGE : NOW PRINT-  
 ING  
 ERROR :  
 WARNING :  
 STATUS :  
 COUNTER :  
 INIT  
 F-FEED  
 B-FEED  
 -> POSITION SET

- ⑫ Exit from the TEST Mode.
- ⑬ Push the ASSY PRINTER up to the point the PRINTER reaches the Securing Part in the innermost of the unit.
- ⑭ Lock the Printer Door to secure.

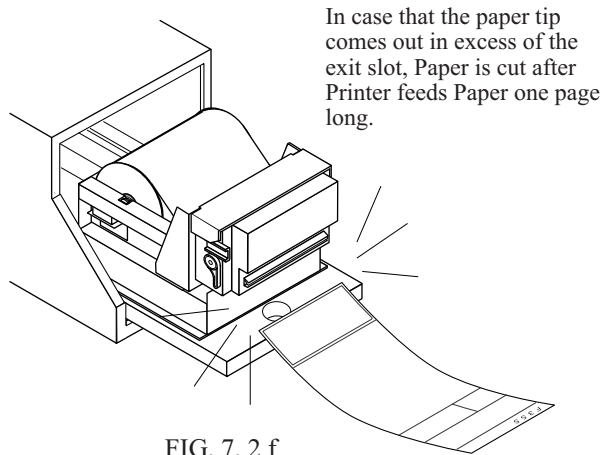

FIG. 7. 2 f

SETTING THE PAPER WITH THE POWER OFF

- ① Turn off power.
- ② Unlock with the Master Key and remove the Printer Door.
- ③ Draw the ASSY Printer toward you.
- ④ Pull up the Head Up Lever.
- ⑤ Take out the roll shaft from the Printer.
- ⑥ Pass the shaft through the core of the new Roll Paper.
- ⑦ Install the roll shaft in which the paper is inserted into the unit. Make sure to put the Roll Paper on to the correct position.

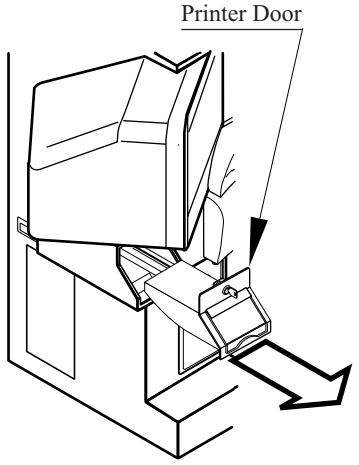
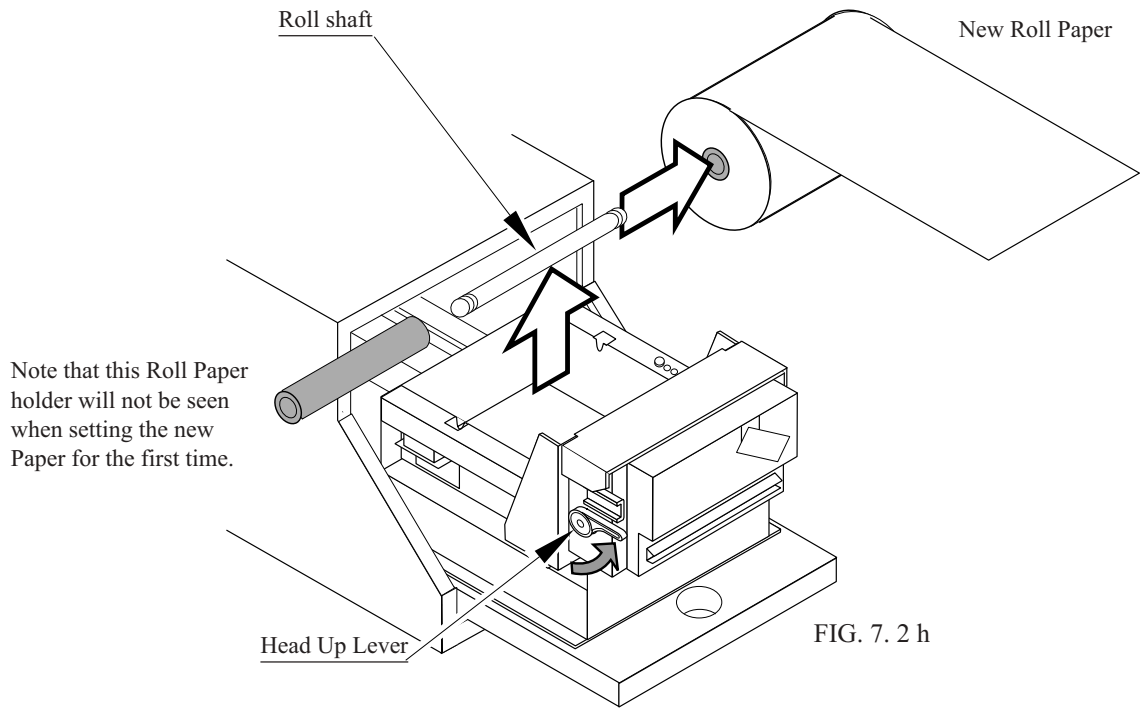
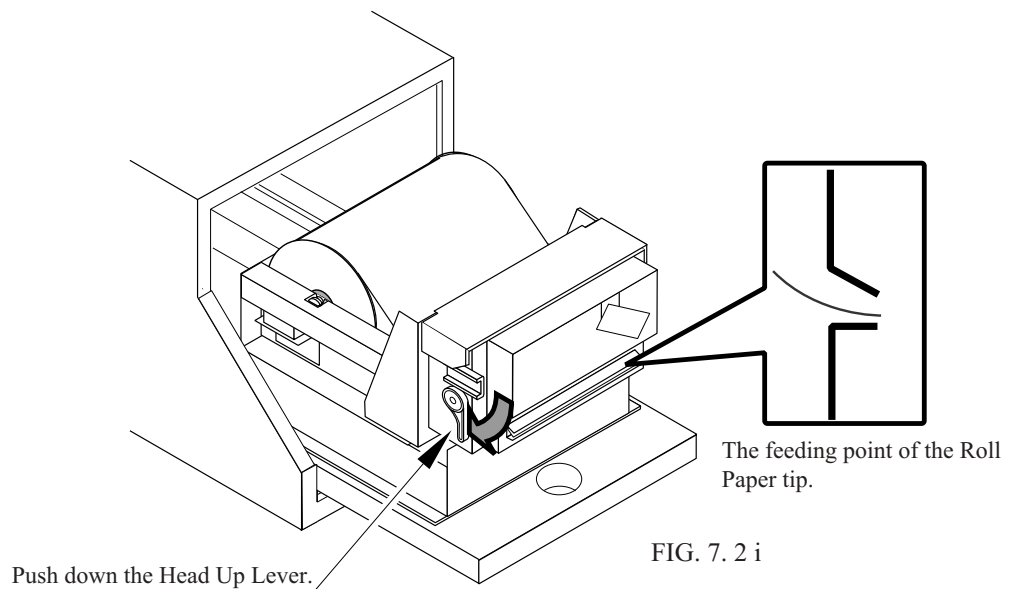

FIG. 7. 2 g



- ⑧ Insert the paper tip in to the Roll Paper insertion slot. Feed the Roll Paper tip through the exit slot straight by hand. At this time, if the Paper tip is in excess of the feeding point, the automatic feeding of Paper is performed and the Paper is cut after feeding about one page long.
- ⑨ Push down the Head Up Lever.



- ⑩ Turn on power. The Printer starts automatic feeding of the paper (AUTO LOADING) and then cuts the paper automatically. If the Paper tip position is appropriate as per previous procedure, the automatic feeding's movement is slight and the paper cutting may not be done.
- ⑪ Push the ASSY PRINTER into the point the PRINTER reaches the securing part in the innermost of the unit.
- ⑫ Lock the Printer Door to secure.

### 7 - 3 CLEANING OF THE PRINTER HEAD

Each time the Roll Paper is supplied, clean the Printer Head. Prepare the cleaning pen which is included in the Print Paper Set exclusively used for this product and a Master Key.

- ① Turn off power.
- ② Unlock with the Master Key and remove the Printer Door.
- ③ Draw the ASSY Printer toward you.
- ④ Push up the Head Up Lever.
- ⑤ Remove the Roll Paper.
- ⑥ Push down the Cutter Lever and open the Auto Cutter.

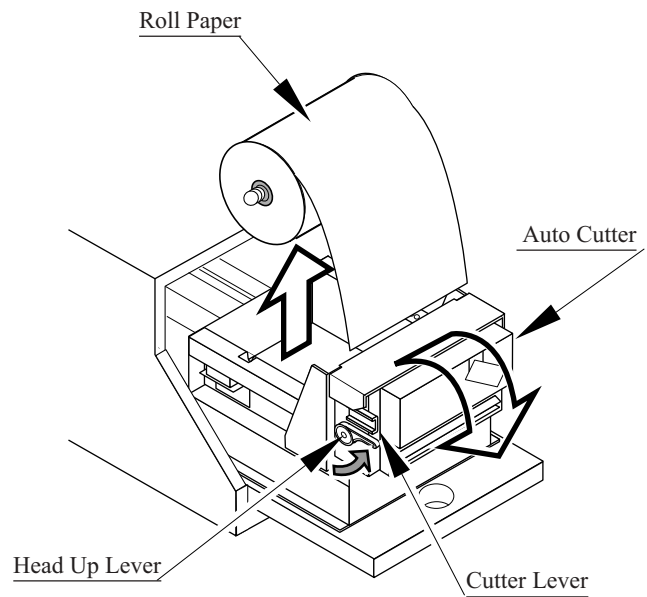

FIG. 7. 3 a

- ⑦ By using the cleaning pen, clean the printer head.

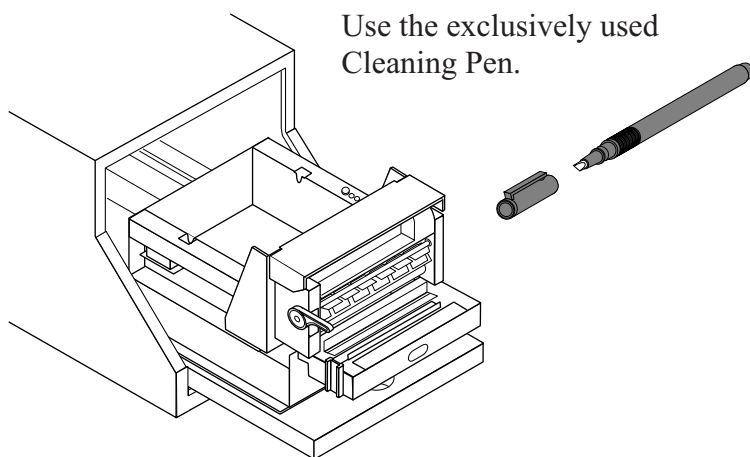

FIG.7. 3 b

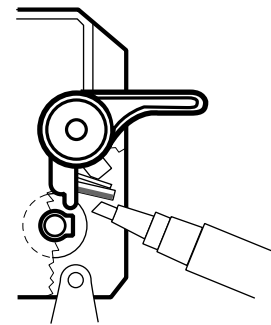

FIG. 7. 3 c

- ⑧ Lift the Auto Cutter and lock.
- ⑨ Set the Roll Paper.
- ⑩ Push down the Head Up Lever and turn on power. The Printer performs automatic feeding and cutting of the paper.
- ⑪ Put the ASSY Printer and lock the printer door to secure.

## 7 - 4 COUNTERMEASURES AGAINST PAPER JAM

Prepare a Master Key and scissors or a knife for eliminating the warped, wrinkled paper due to paper jam. To perform the following work, turning off power is necessary for 2 reasons. One is that performing work on the energized Cabinet may cause hands and fingers to be injured due to unexpected move of the cutter or the motor. To avoid such an unforeseen accident, be sure to turn off power before performing work. The other reason is that in order to remove the cause of error from the Printer, turning power off is necessary. Be sure to remove the cause of error to make the Printer function properly.

- ① Turn off power.
- ② Unlock with the Master Key and remove the Printer Door.
- ③ Draw the ASSY Printer toward you.
- ④ Pull up the Head Up Lever.
- ⑤ Push down the Cutter Lever and open the Auto Cutter.
- ⑥ Remove the jammed paper.

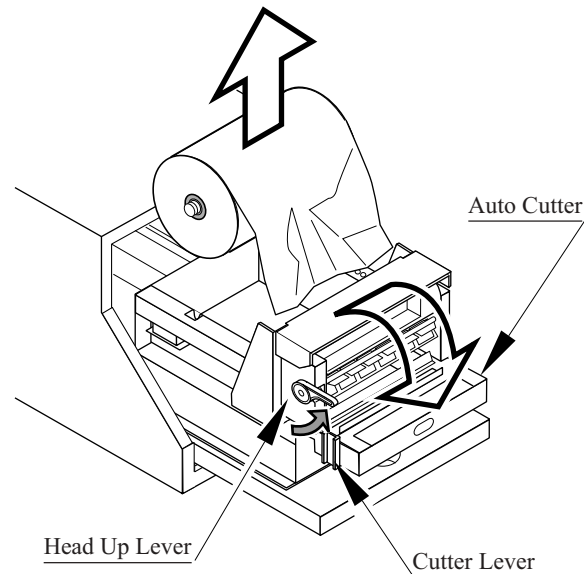

FIG. 7. 4 a

- ⑦ Eliminate the warped, wrinkled paper due to the paper jam. At this time, after eliminating the paper, any portion can come to the tip as the Printer automatically adjusts the Paper position by feeding and cutting the Paper.

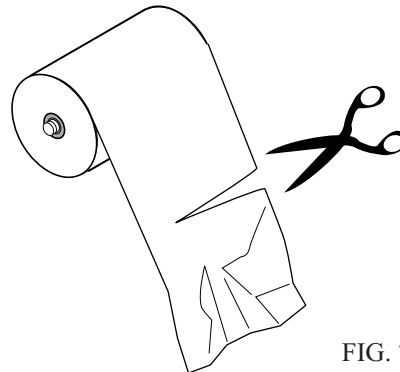

FIG. 7. 4 b

- ⑧ Lift the Auto Cutter and lock.
- ⑨ Insert the paper tip in to the roll paper insertion slot. Feed the Roll Paper tip through the exit slot straight by hand until the paper tip can be seen from the exit slot.
- ⑩ Pull up the Head Up Lever.
- ⑪ Turn on power. The Printer performs automatic feeding (AUTO LOADING) and cutting of the paper.
- ⑫ Put the ASSY Printer and lock the printer door to secure.

## 8. PRECAUTIONS TO BE HEHEDED WHEN MOVING THE MACHINE



WARNING!

- When moving the machine, be sure to unplug the power plug. Moving the machine with the plug as is inserted can damage the power cord and cause fire and electric shock hazards.
- When moving the machine on the floor, retract the Adjusters and ensure that Casters make contact with the floor. During transportation, pay careful attention so that Casters do not tread power cords and earth wires. Damaging the power cords can cause electric shock and short circuit hazards.
- When lifting the cabinet, be sure to hold the grip portions or bottom part. Lifting the cabinet by holding other portions can damage parts and installation portions due to the empty weight of the cabinet, and cause personal injury.
- In the case the cabinet is separated into the front and rear portions, do not push the upper rear part of the front cabinet. Failure to observe this causes the front cabinet to fall down towards the monitor side and result in accidents and injury to persons. When moving the front cabinet in the above case, be sure to push it from side directions and move it by 2 or more persons for safety.
- Do not insert the fork to places other than designated when using a Forklift to transport the machine.  
Failure to observe this could cause falling down and injury resulting from falling down.



CAUTION!

Do not push glass-made or plastic parts. Failure to observe this may damage parts and cause injury due to fragments resulting from damage.



IMPORTANT!

- When transporting the product in places with steps, disassemble into each unit before transporting. Inclining the product in an as is assembled condition or placing the cabinet in places with steps can damage the unit's joining portions.
- To protect surface, do not directly apply a rope to the surfaces of product. Use protective materials to the places the rope is applied to.

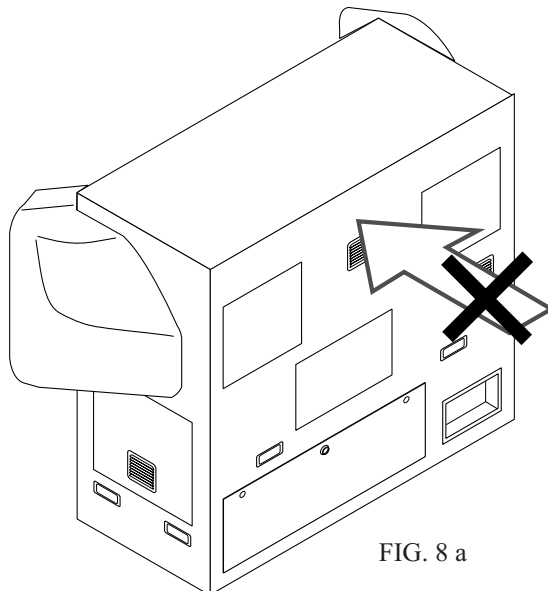

In the case the cabinet is separated into the front and rear portions, do not push the upper rear part of the front cabinet.

FIG. 8 a

When transporting the product in places with steps or step-like differences in grade, disassemble into each unit before transporting.

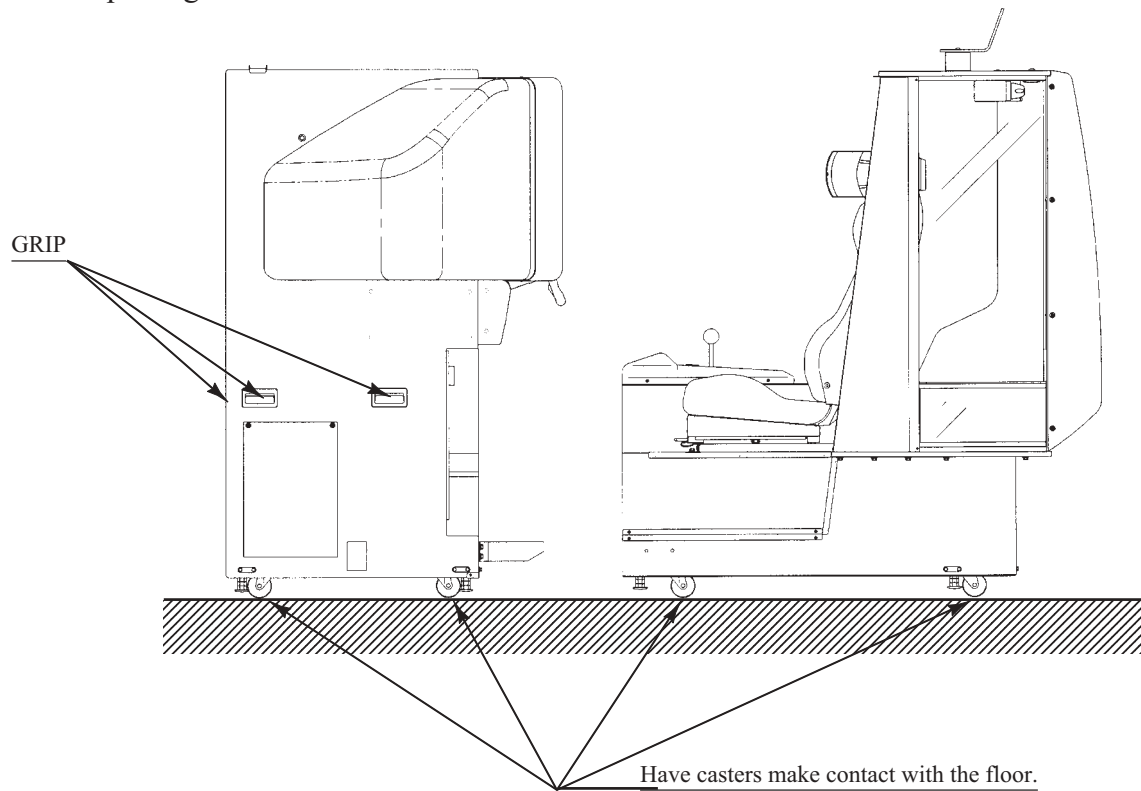

FIG. 8 b

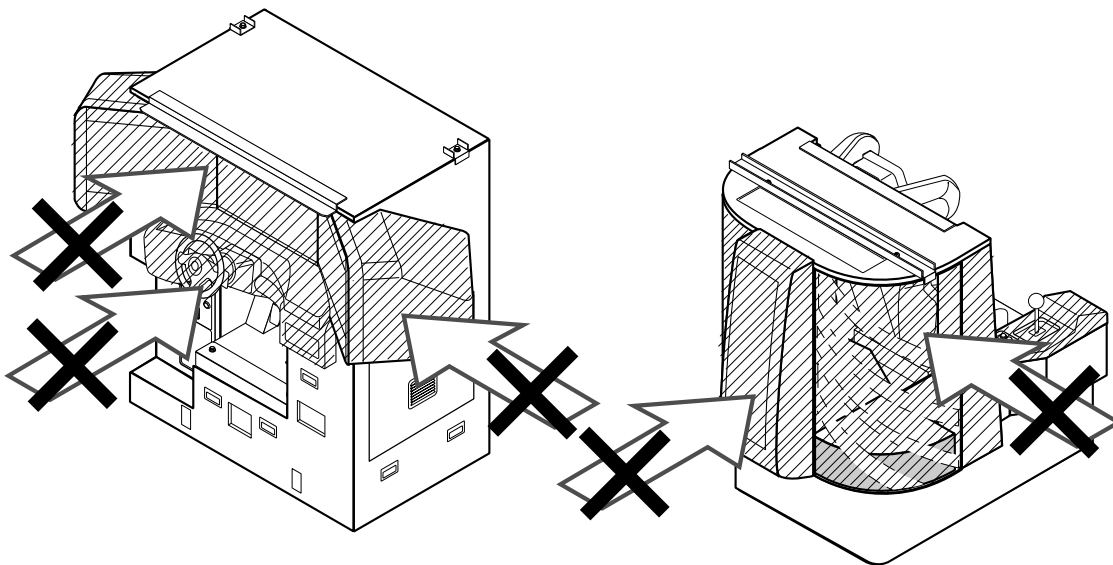
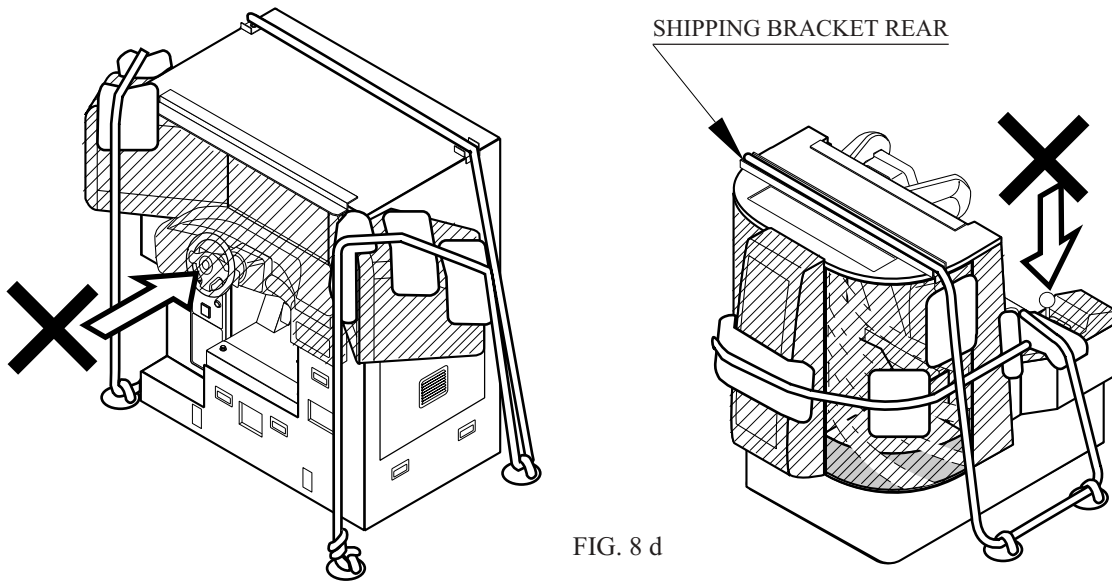

FIG. 8 c

Precautions concerning applying a rope.



- Do not apply a rope to Handle or Lever.
- Use protective materials to the places the rope is applied to.

Caution when transporting the machine

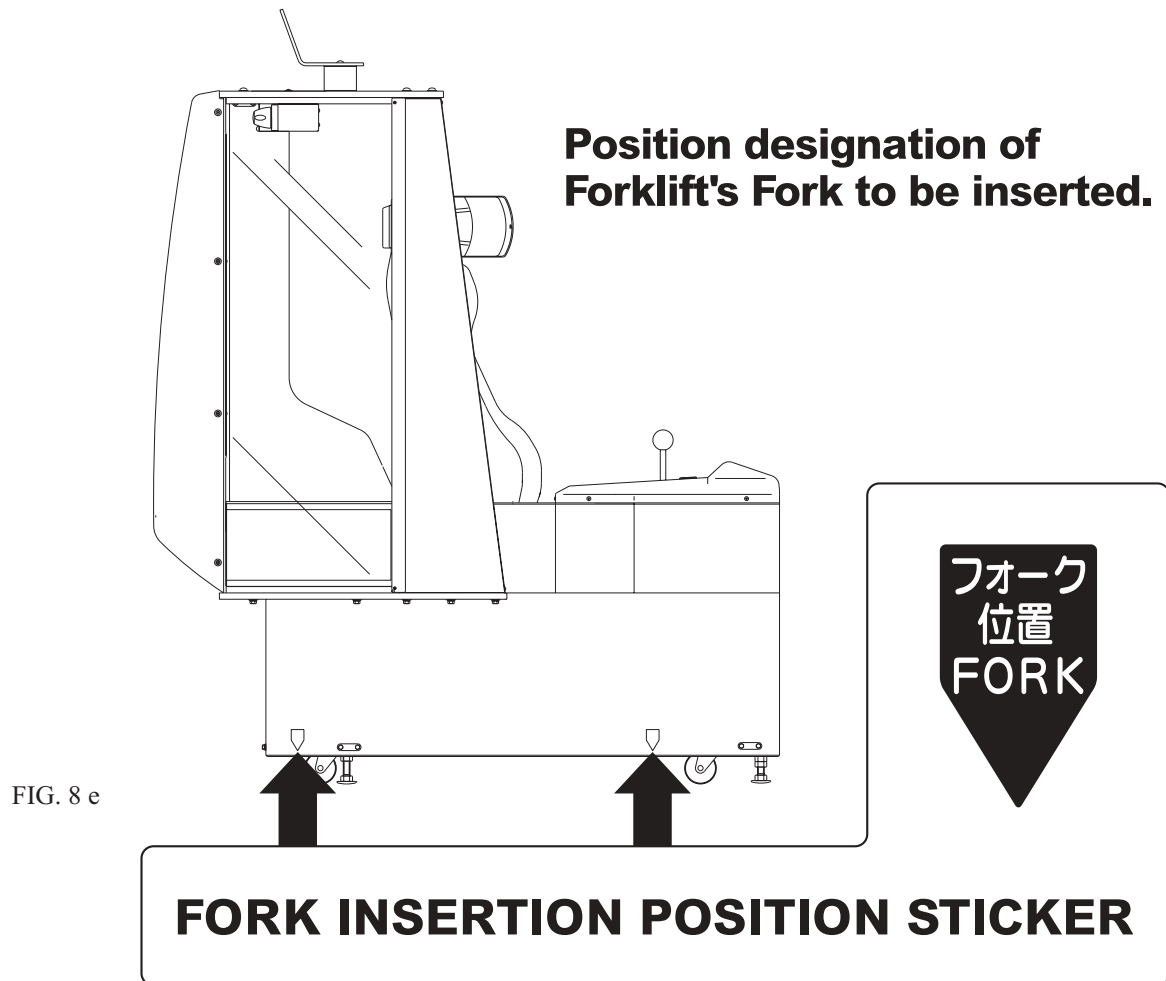



## 9. HANDLE MECHA



- Before starting to work, ensure that the Power SW is OFF. Failure to observe this can cause electric shock or short circuit.
- Use care so as not to damage wirings. Damaged wiring can cause electric shock or short circuit.
- Do not touch undesignated places. Touching places not designated can cause electric shock or short circuit.
- This work should be performed by the Location's Maintenance Man or Serviceman. Performing work by non-technical personnel can cause electric shock hazard.
- Do not insert hand into the mechanism so as not to cause hand and fingers pinched in. Failure to observe this can cause a serious injury such as a fracture.
- When performing work such as parts replacement other than those specified in this manual, be sure to contact where you purchased the product from and confirm the work procedures and obtain precautions prior to performing work. Inappropriate parts replacement and/or installing with erroneous adjustment can cause an overload or the parts to come into contact, resulting in an electric shock, a short circuit, and a fire.



When adjusting the Volume, be sure to use 2 workers.

**IMPORTANT!**

### 9 - 1 ADJUSTING OR REPLACING THE V.R.

In cases the Steering operability is poor and the adjustment of VOLUME SETTING in the TEST mode is ineffective, the causes may be the Volume Gear's mesh failure and or Volume malfunctioning. By using the following procedure, adjust Volume gear mesh, or replace the Volume. In this product, when the Steering Wheel is moved fully left/right, if the Volume shaft is rotating within the movable range, the Volume is not feared to be damaged. Secure the Volume in the manner the Volume shaft is oriented as shown and the gears are appropriately engaged when the steering wheel is in the centering position allowing the car to go straight forward.

#### ADJUSTING THE VOLUME

Be sure to use 2 workers in adjusting the Volume, one is for operating the Steering Wheel and the other one for performing the adjustment.

- ① Turn off power.
- ② Take out 4 Truss screws to remove the Rear Lid from the back of Front Cabinet. At this time, carefully support the Rear Lid as taking out the 4 Truss screws can cause the Rear Lid to drop.

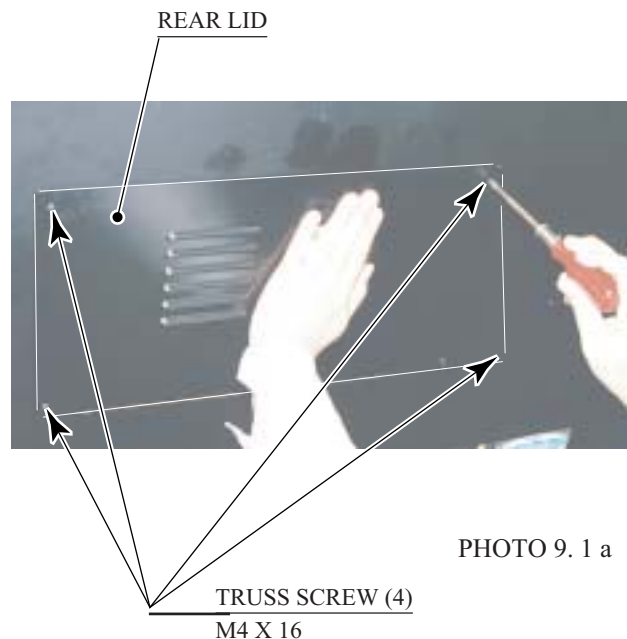

PHOTO 9. 1 a

- ③ Perform the adjustment while another person is securing the Steering Wheel in the centering position.
- ④ The V.R. is on the VR BASE (a white, plastic made part). Loosen the 2 screws which secure the VR BASE and adjust the angle and appropriateness of gear mesh by moving the VR BASE.
- ⑤ Adjust to an appropriate mesh by securing the Steering Wheel in the direction allowing the car to advance straight forward and ensuring the "D" CUT FACE of the Volume shaft is oriented as shown.
- ⑥ Tighten the 2 screws to secure the VR BASE.

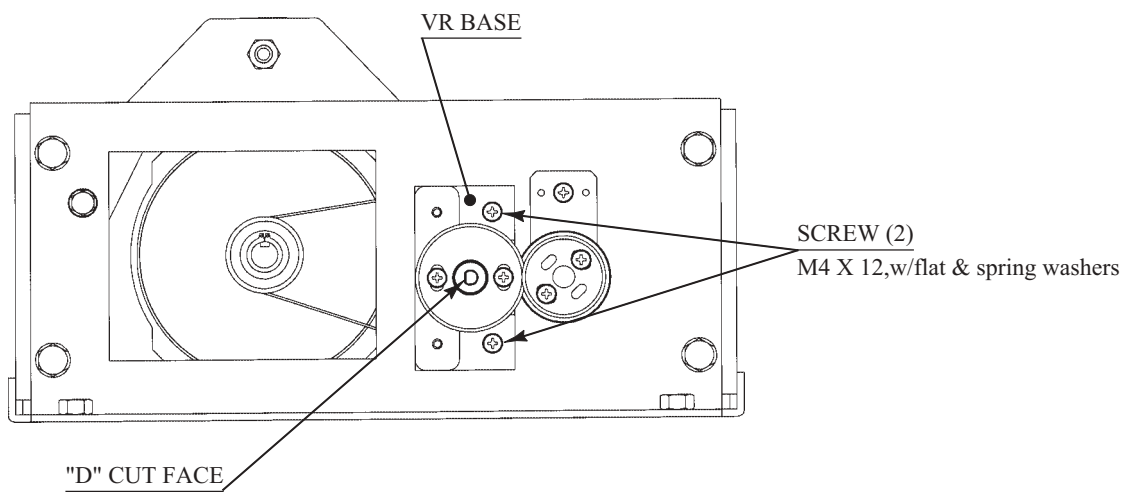
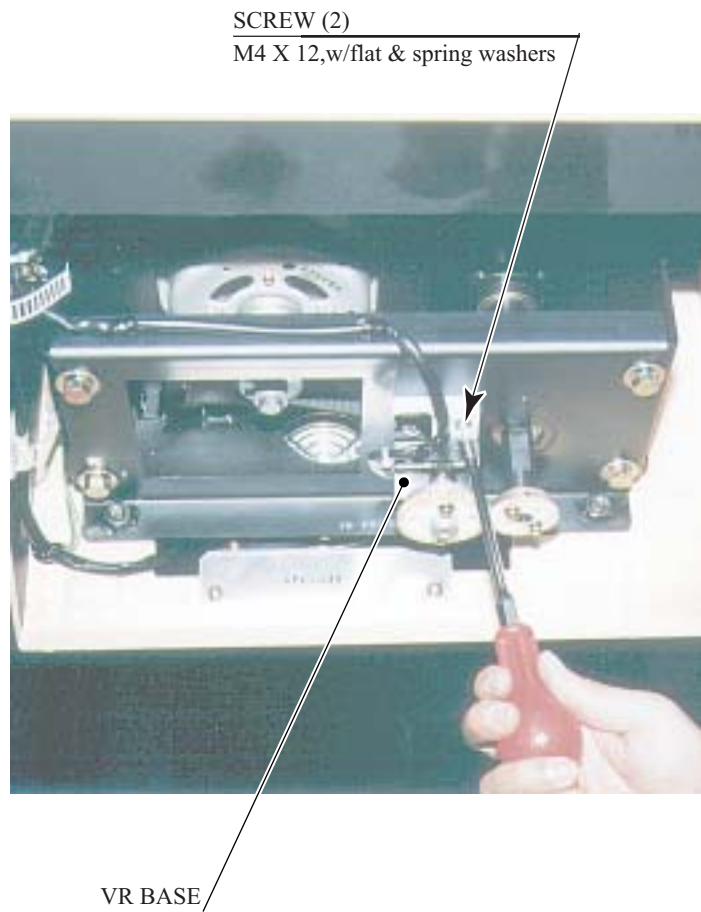

FIG. 9. 1 a

- ⑦ Turn on power.
- ⑧ Set the Center Value of the Volume in the TEST mode.
- ⑨ In the TEST mode, check to see if the Volume Value varies smoothly in accordance with the steering wheel operation.

## REPLACING THE VOLUME

- ① Disconnect the connector from the Volume.
- ② Take out 2 screws to remove the Volume together with VR BASE from the HANDLE MECHA.



- ③ Take out 2 screws from the VR BASE reverse side to remove the Volume together with VR Bracket from the VR BASE.
- ④ Remove the Volume from VR Bracket and replace.

TRUSS SCREW (2)  
M4 X 12

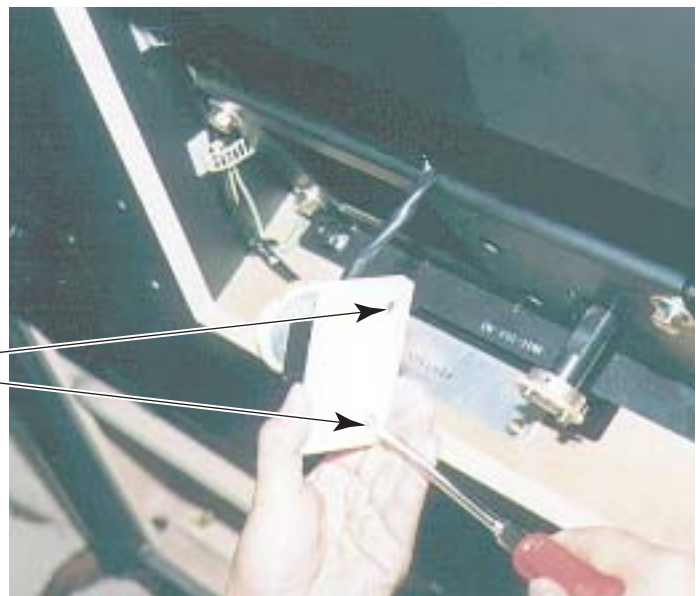

- ⑤ After replacing the Volume, engage the gears at the angular position shown and fix the VR Bracket.

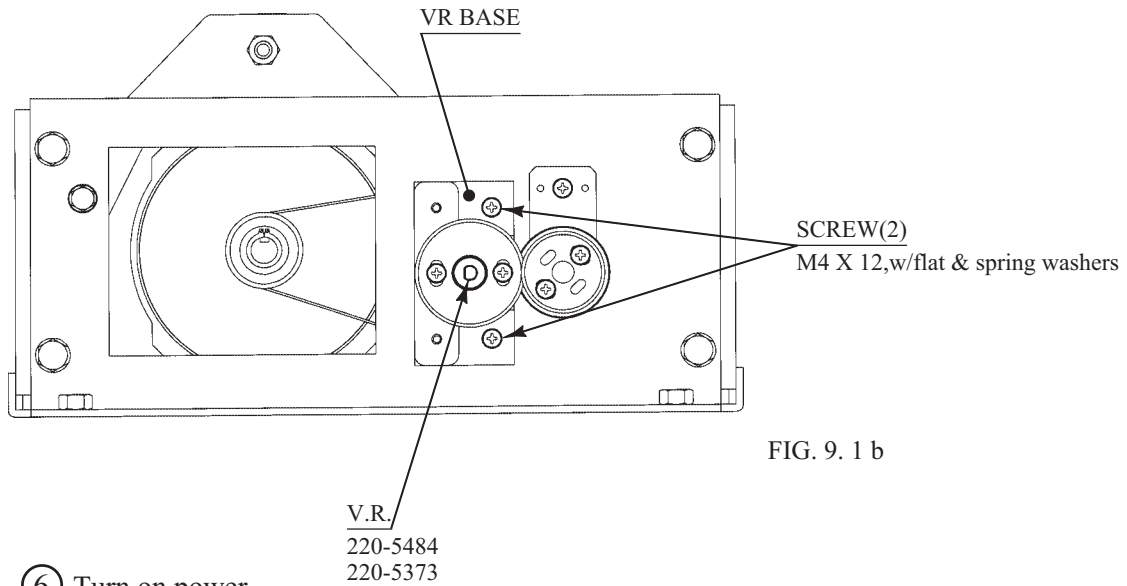

FIG. 9. 1 b

- ⑥ Turn on power.
- ⑦ Set the Center Value of the Volume in the TEST mode.
- ⑧ In the TEST mode, check to see if the Volume Value varies smoothly in accordance with the steering wheel operation.

## 9 - 2 GREASING



- Be sure to use the designated grease. Using undesignated grease can cause parts damage.
- Do not apply greasing to undesignated places. Failure to observe this can cause malfunctioning or quality deterioration of parts.

Apply greasing to gear mesh portions once every 3 months.  
Use GREASE MATE (SEGA PART NO. 090-0066).

VOLUME GEAR MESH PORTION

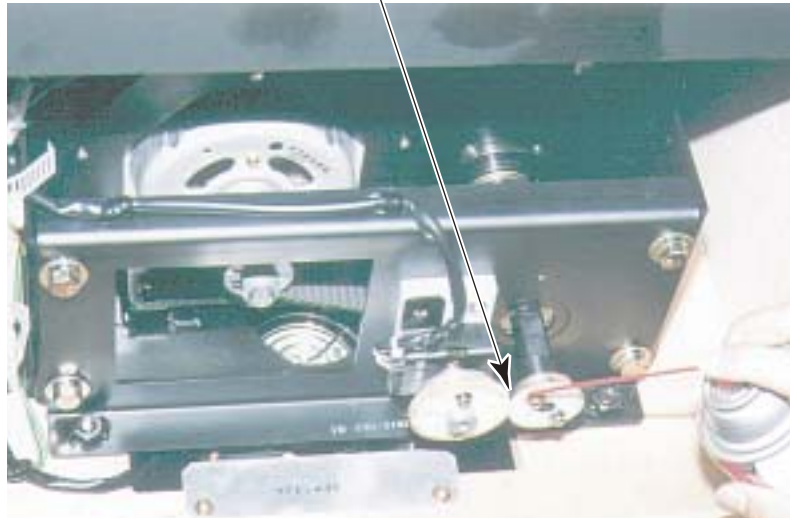

PHOTO 9. 2

### 9 - 3 REPLACING PADDLE (WING) SHIFT SWITCH

In case the Paddle Shift operability is poor, malfunctioning of or a damage to the Microswitch inside the Paddle Shift can be considered.

- ① Turn off power.
- ② Take out 2 Truss screws for each to remove Boss Cover Upper and Lower.
- ③ Disconnect the wiring connected to the Microswitch.

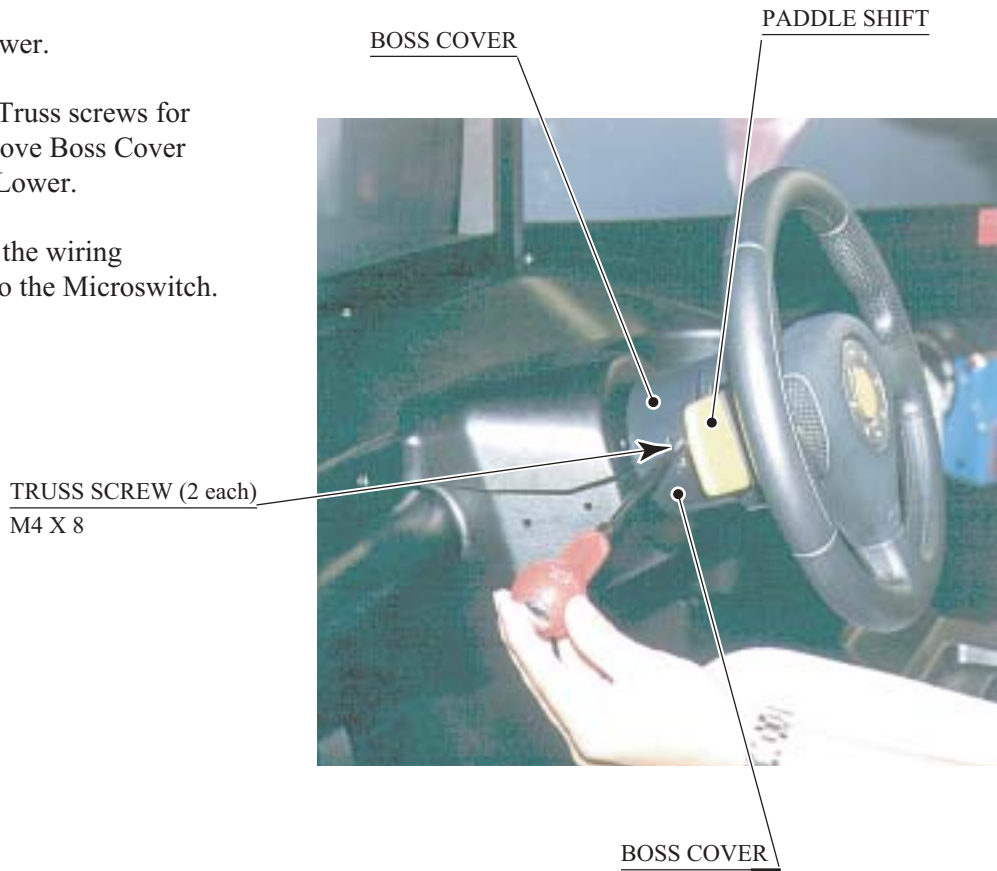

PHOTO 9. 3 a

SCREW (2)  
M3 X 16

- ④ Take out 2 screws to replace the Microswitch.
- ⑤ Adjust Microswitch's actuator to an angular position so as not to touch the Switch when operating the Shift Lever.
- ⑥ Fasten 2 screws to secure the Microswitch.
- ⑦ Check to ensure that the Switch goes ON and OFF in consistency with the operation.



MICROSWITCH  
509-5387

PHOTO 9. 3 b



## 10. 6-SPEED SHIFT



WARNING!

- Before starting to work, ensure that the Power SW is OFF. Failure to observe this can cause electric shock or short circuit.
- Use care so as not to damage wirings. Damaged wiring can cause electric shock or short circuit.
- Do not touch undesignated places. Touching places not designated can cause electric shock or short circuit.
- This work should be performed by the Location's Maintenance Man or Serviceman. Performing work by non-technical personnel can cause electric shock hazard.
- When performing work such as parts replacement other than those specified in this manual, be sure to contact where you purchased the product from. Confirm the work procedures and obtain precautions from where you purchased the product from prior to performing work. Inappropriate parts replacement and/or installation with erroneous adjustment can cause an overload or the parts to come into contact, resulting in an electric shock, a short circuit, and a fire.

### 10 - 1 REMOVING THE SHIFT LEVER

- ① Turn off power.
- ② Take out 4 screws securing the EFFECT Switch.
- ③ Take out 5 Truss screws which secure the Console Cover.

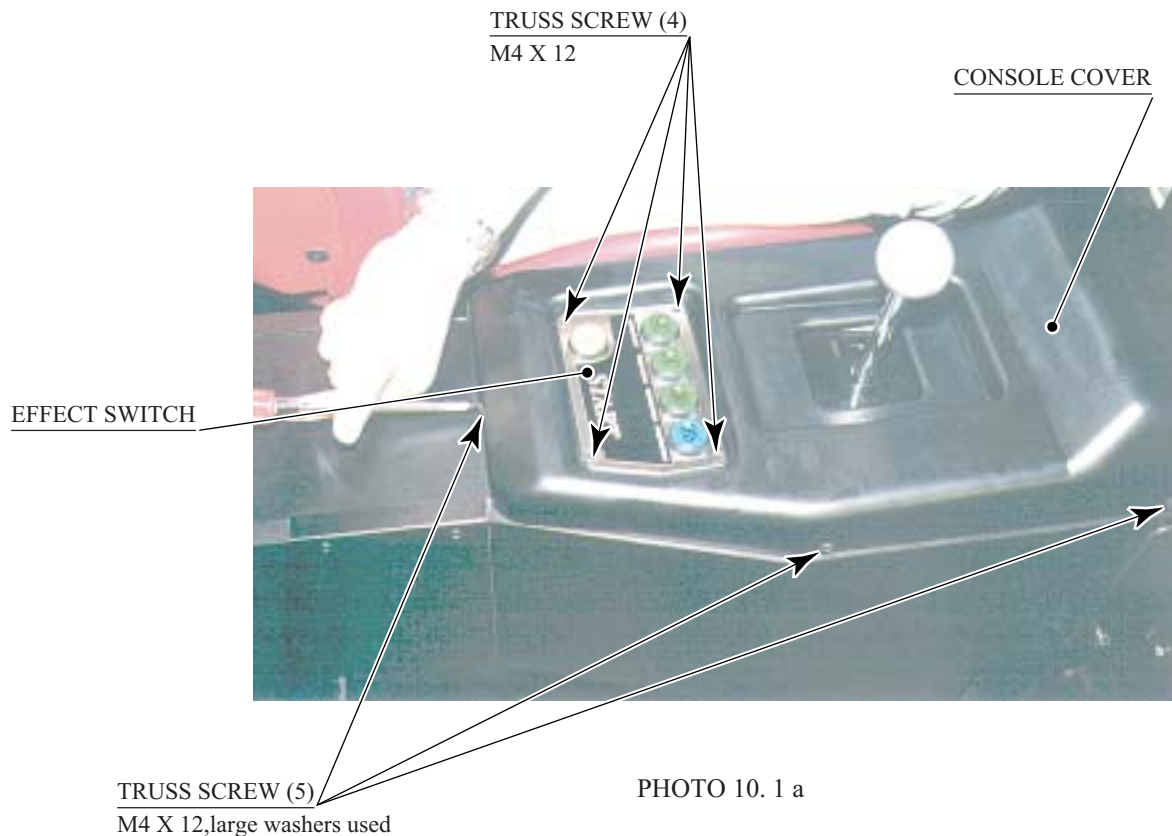

- ④ Disconnect a connector.
- ⑤ Take out 4 Hexagon Bolts.

HEXAGON BOLT (4)  
M8 X 40,w/flat & spring washers

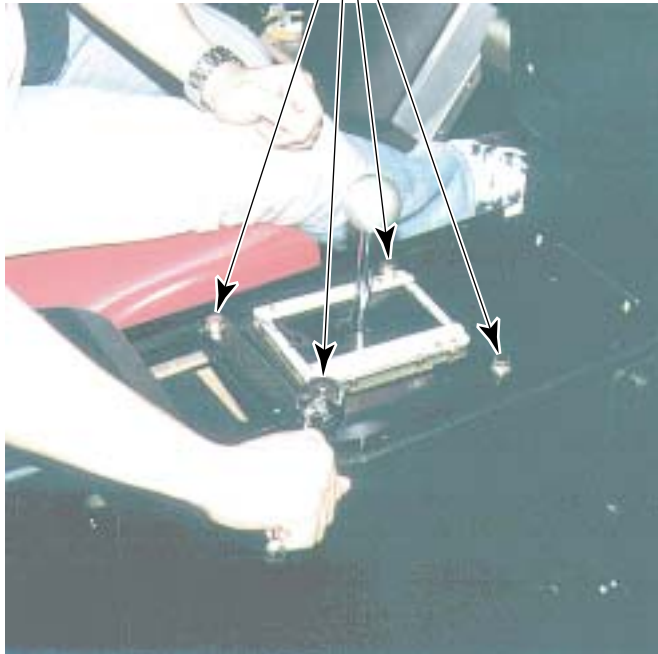

PHOTO 10. 1 c

- ⑥ Lift the 6-speed Shift vertically. At this time, use care so as not to hang the wiring or hit the other parts.
- ⑦ Disconnect 2 connectors to remove the 6-speed Shift.



Disconnect the connector

PHOTO 10. 1 b

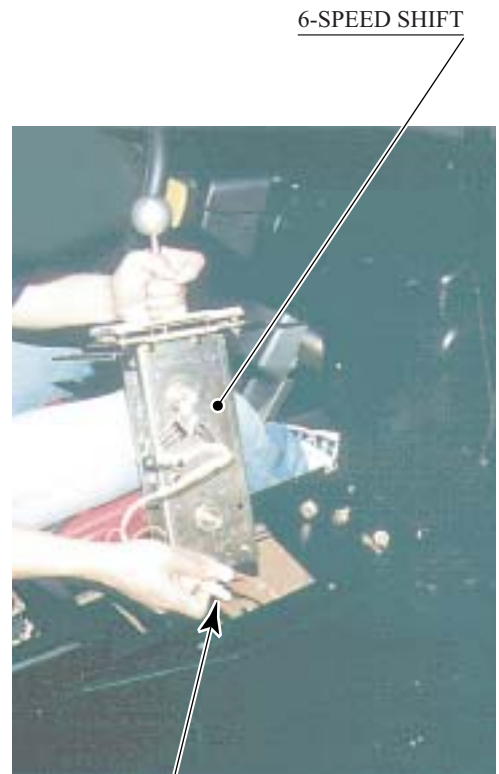

PHOTO 10. 1 d

Disconnect the connector



## 10 - 2 REPLACING THE SWITCH

In case 6-speed Shift operability is poor, malfunction of or damage to the Microswitch of Mechanism can be considered. The 6-speed Shift has 4 Microswitches. Be sure to check which Switch malfunctions prior to performing work.

- ① Remove 6-speed Shift as per procedure 10-1.
- ② Disconnect the wiring connected to the Microswitch.
- ③ Take out 2 screws to replace the Microswitch.
- ④ Adjust Microswitch's actuator to an angular position so as not to touch the Switch when operating the Shift Lever.
- ⑤ Fasten 2 screws to secure the Microswitch.

MICROSWITCH  
509-5636



PHOTO 10. 2 a

- ⑥ Check to ensure that the Switch goes ON and OFF in consistency with the operation.

MICROSWITCH  
509-5636

SCREW (2)  
M2.3 X 10,w/flat & spring washers

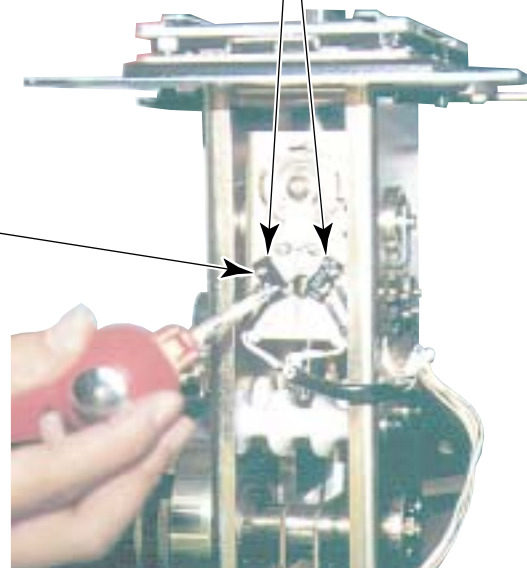

PHOTO 10. 2 b

# 11. ACCELERATOR & BRAKE



- Before starting to work, ensure that the Power SW is OFF. Failure to observe this can cause electric shock or short circuit.
- Use care so as not to damage wirings. Damaged wiring can cause electric shock or short circuit.
- Do not touch undesignated places. Touching places not designated can cause electric shock or short circuit.
- This work should be performed by the Location's Maintenance Man or Serviceman. Performing work by non-technical personnel can cause electric shock hazard.
- When performing work such as parts replacement other than those specified in this manual, be sure to contact where you purchased the product from. Confirm the work procedures and obtain precautions from where you purchased the product from prior to performing work. Inappropriate parts replacement and/or installation with erroneous adjustment can cause an overload or the parts to come into contact, resulting in an electric shock, a short circuit, and a fire.

If Accel. and Brake operation is not satisfactory, adjustment of Volume installation position or Volume replacement is needed. Also, be sure to apply greasing to the gear mesh portion once every 3 months.

## 11 - 1 ADJUSTING AND REPLACING THE V.R.

The appropriate value for both ACCEL. Volume and Brake Volume is under 30H when released and over C0H when stepped on. Check Volume values in the TEST mode. Since work is performed inside the energized cabinet, be very careful so as not to touch undesignated places. Touching places not specified can cause electric shock or short circuit.

- ① Take out the 2 truss screws and remove the Front Cover from the Accel. & Brake Unit (FIG. 11. 1 a).
- ② Loosen the screw which secure the Potentiobase, and adjust the Volume value by moving the Base. (FIG. 11. 1 b)
- ③ Secure the Potentiobase.
- ④ Perform Volume setting in the Volume setting mode.

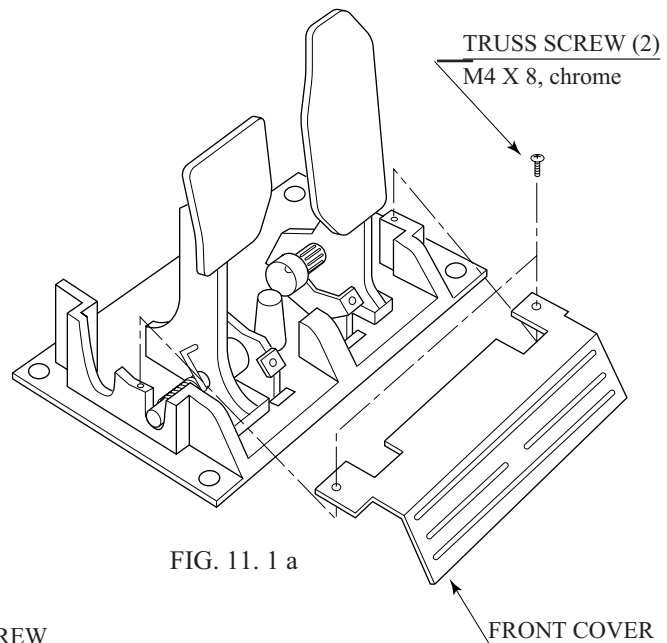

FIG. 11. 1 a

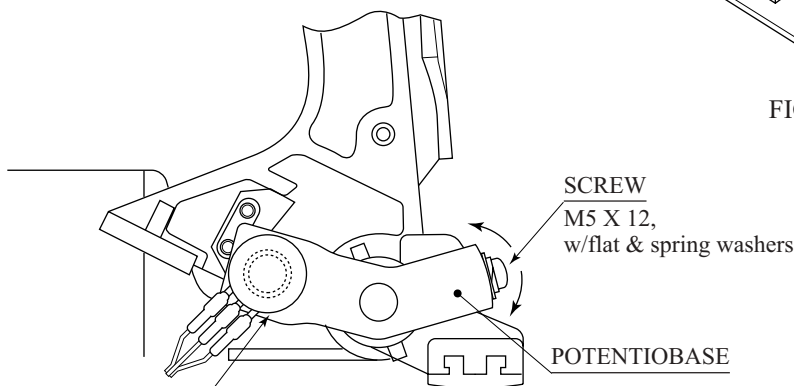
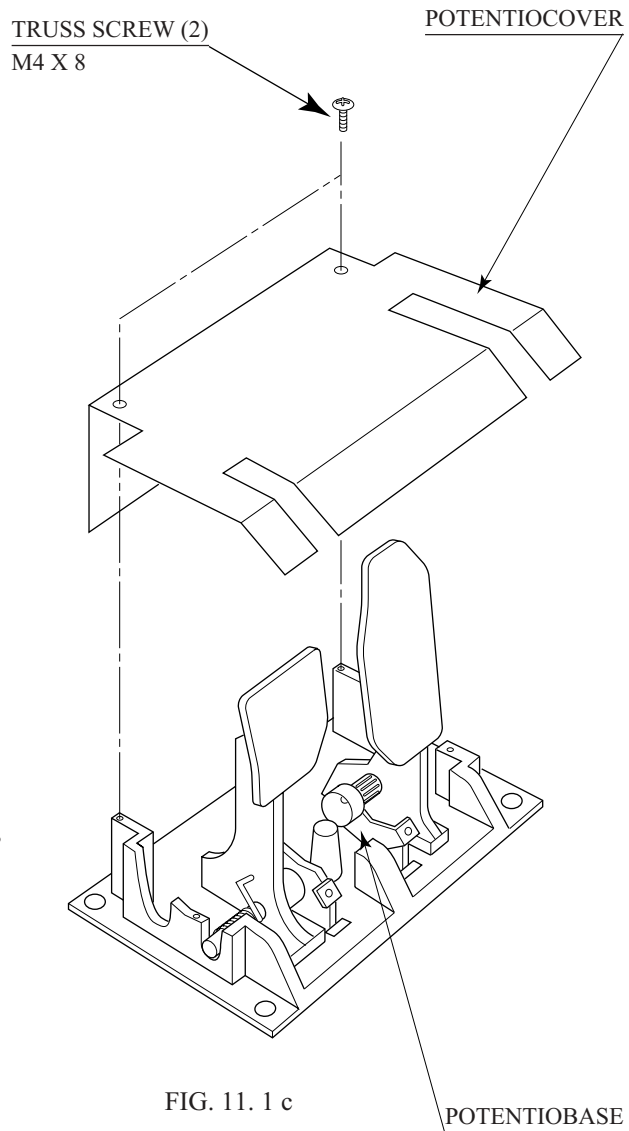

FIG. 11. 1 b

V.R.  
220-5484  
220-5373

## REPLACING THE VOLUME

- ① Turn the power off.
- ② Take out the 2 screws and remove the Potentiocover (FIG. 11. 1 c).
- ③ Disconnect the connector of the Volume to be replaced.
- ④ Remove the screw which secures the Potentiobase (FIG. 11. 1 b).
- ⑤ Remove the Potentiobase together with the Volume as is attached. (FIG. 11. 1 c)
- ⑥ Remove the Base and Gear to replace the Volume.
- ⑦ Adjust the Volume as per the previous page after replacing.



## 11 - 2 GREASING



IMPORTANT!

Be sure to use the designated grease. Using undesignated grease can cause parts damage.

Once every 3 months, apply greasing to the Spring and Gear mesh portion. For spray greasing, use GREASE MATE (PART No. 090-0066).

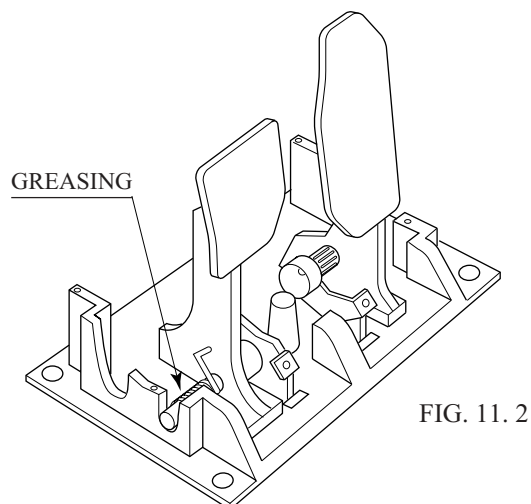

## 12. CLUTCH PEDAL



WARNING!

- Before starting to work, ensure that the Power SW is OFF. Failure to observe this can cause electric shock or short circuit.
- Use care so as not to damage wirings. Damaged wiring can cause electric shock or short circuit.
- Do not touch undesignated places. Touching places not designated can cause electric shock or short circuit.
- This work should be performed by the Location's Maintenance Man or Serviceman. Performing work by non-technical personnel can cause electric shock hazard.
- When performing work such as parts replacement other than those specified in this manual, be sure to contact where you purchased the product from. Confirm the work procedures and obtain precautions from where you purchased the product from prior to performing work. Inappropriate parts replacement and/or installation with erroneous adjustment can cause an overload or the parts to come into contact, resulting in an electric shock, a short circuit, and a fire.

If the Clutch Pedal's operation is not satisfactory, the V.R. installation position adjustments or V.R. replacement is needed. Also, be sure to apply greasing to the V.R. Gear mesh portion and the 2 Springs once every 3 months.

### 12 - 1 REMOVING THE CRUTCH PEDAL

- ① Turn off power.
- ② Take out 4 Hexagon Bolts. At this time, support the Clutch Pedal as taking out the bolts can cause the Clutch Pedal to fall.

PHOTO 12. 1 a

HEXAGON BOLT (4)  
M8 X 30,w/spring washer



- ③ Take out a screw to remove the earth wire which is connected to the Clutch Pedal Mechanism side.

SCREW (1)  
M4 X 8,w/flat & spring washers

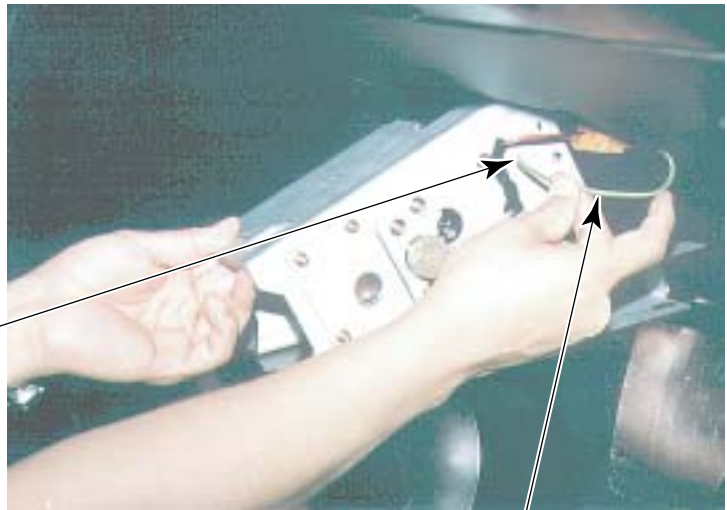

EARTH

PHOTO 12. 1 b

- ④ Disconnect the connector to remove the Clutch Pedal.

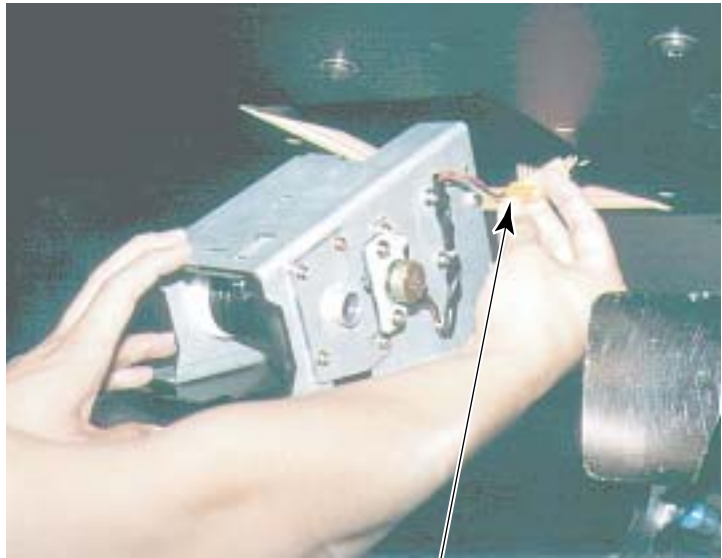

Disconnect the connector

PHOTO 12. 1 c

## 12 - 2 VOLUME ADJUSTMENT/REPLACEMENT

The appropriate value of Crutch Volume is under 30H when released and over C0H when stepped on. Check Volume values in the TEST mode. Since work is performed inside the energized cabinet, be very careful so as not to touch undesigned places. Touching places not specified can cause electric shock or short circuit.

### ADJUSTING THE VOLUME

- ① Loosen 2 screws which secure the Volume Bracket to adjust the gear mesh.
- ② Tighten the 2 screws.
- ③ In the TEST mode, check to ensure that the Volume Values are within the appropriate range and vary smoothly in consistency with the Pedal operation.

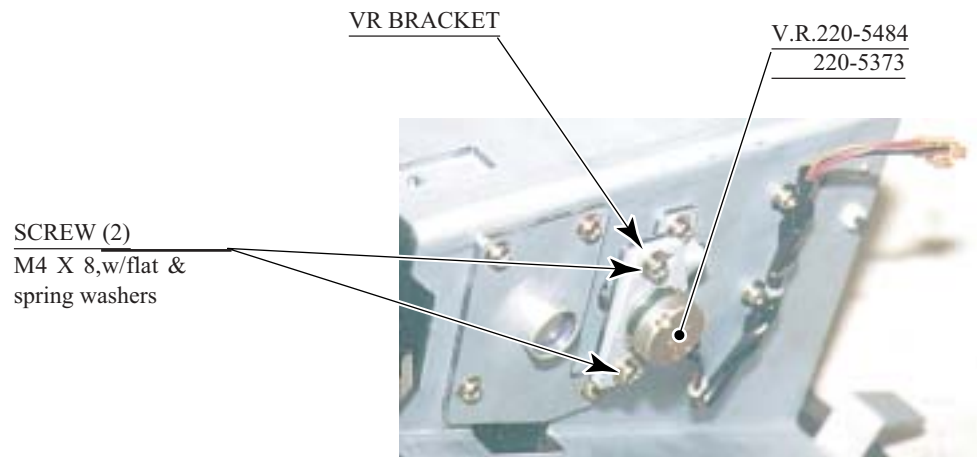

PHOTO 12. 2

### REPLACING THE VOLUME

- ① Disconnect the connector from the Volume.
- ② Take out 2 screws to remove the Volume together with the VR Bracket from the Crutch Pedal Mechanism.
- ③ Remove the Volume from the VR Bracket to replace.
- ④ After replacing the Volume, engage the gears and fix the VR Bracket.
- ⑤ In the TEST mode, check to ensure that the Volume Values are within the appropriate range and vary smoothly in consistency with the Pedal operation.



12 - 3 GREASING



**IMPORTANT!**

Be sure to use the designated grease. Using undesignated grease can cause parts damage.

Once every 3 months, apply greasing to the Spring and Gear mesh portion. For spray greasing, use GREASE MATE (PART No. 090-0066).

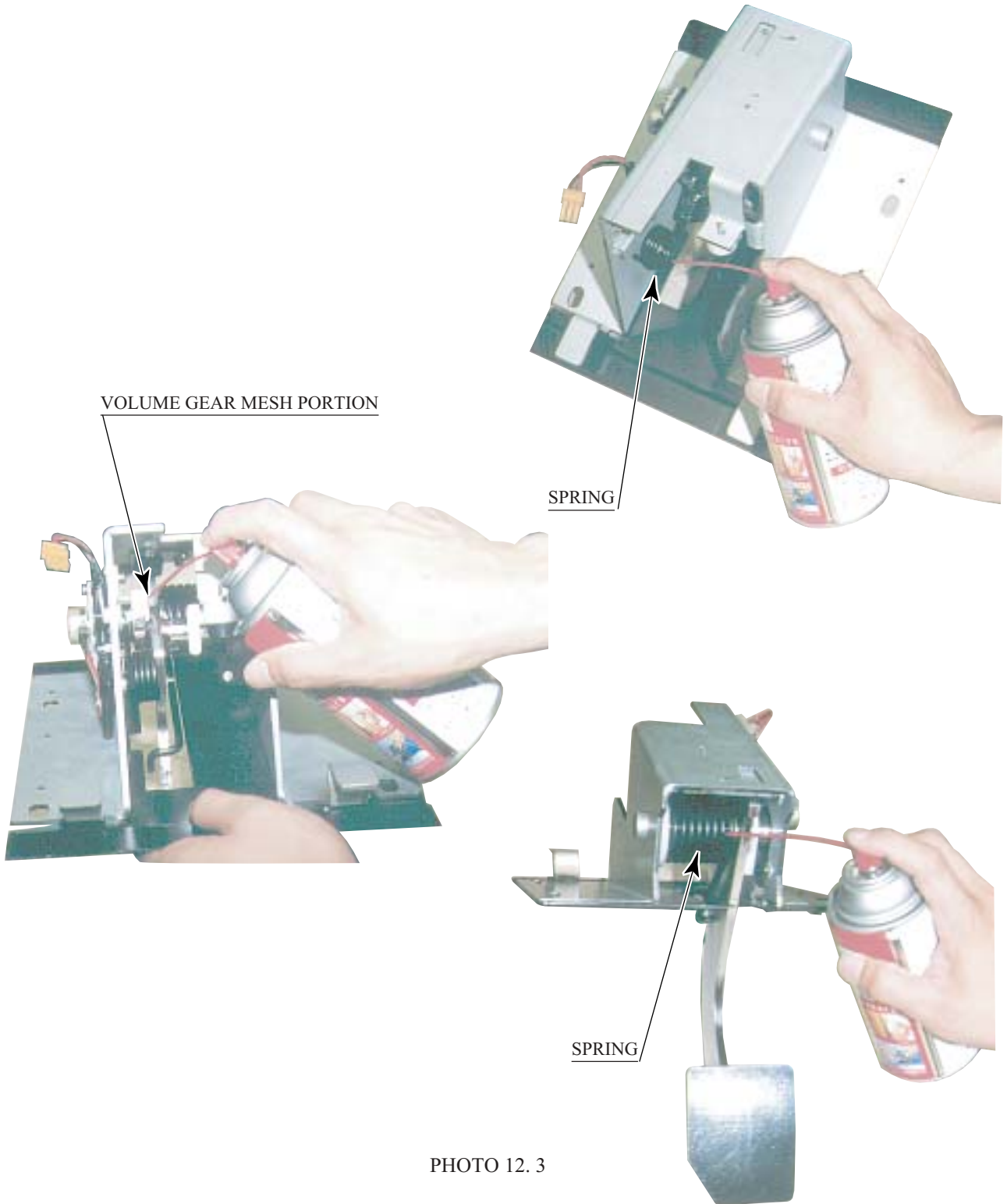

PHOTO 12.3

# 13. COIN SELECTOR

## HANDLING THE COIN JAM

If the coin is not rejected when the REJECT button is pressed, open the coin chute door and open the selector gate. After removing the jammed coin, put a normal coin in and check to see that the selector correctly functions.

## CLEANING THE COIN SELECTOR



- Remove and clean smears by using a soft cloth dipped in water or diluted chemical detergent and then squeezed dry.
- Never apply machine oil, etc. to the Coin Selector.
- After cleaning the Coin Selector, insert a regular coin in the normal working status and ensure that the Selector correctly functions.

- ① The coin selector should be cleaned once every 3 months. When cleaning, follow the procedure below:
- ② Turn the power for the machine OFF. Open the coin chute door. Open the gate and dust off by using a soft brush (made of wool, etc.).
- ③ Remove and clean smears by using a soft cloth dipped in water or diluted chemical detergent and then squeezed dry.
- ④ Remove the CRADLE. When removing the retaining ring (E ring), be very careful so as not to bend the rotary shaft.
- ⑤ Remove stain from the rotary shaft and shaft receiving portions by wiping off with a soft cloth, etc.
- ⑥ After wiping off as per ⑤ above, further apply a dry cloth, etc. to cause the coin selector to dry completely.

### COIN INSERTION TEST

Once every month, when performing the Coin SW Test, simultaneously check the following:

- Does the Coin Meter count satisfactorily?
- Does the coin drop into the Cashbox correctly?
- Is the coin rejected when inserted while keeping the Reject Button pressed down?

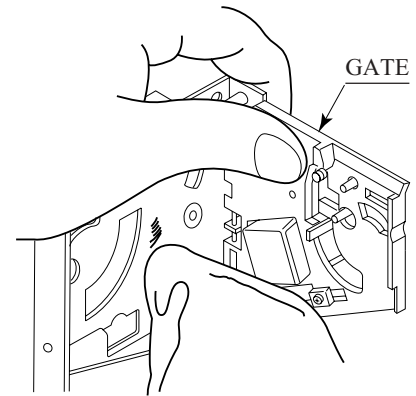

FIG. 13 a

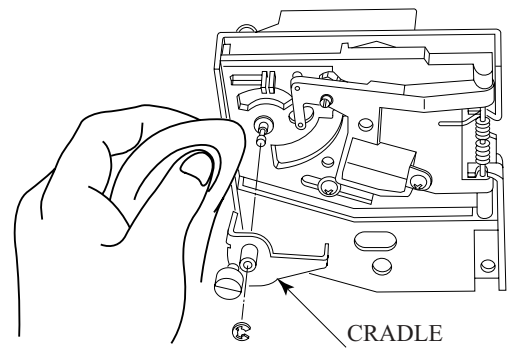

FIG. 13 b

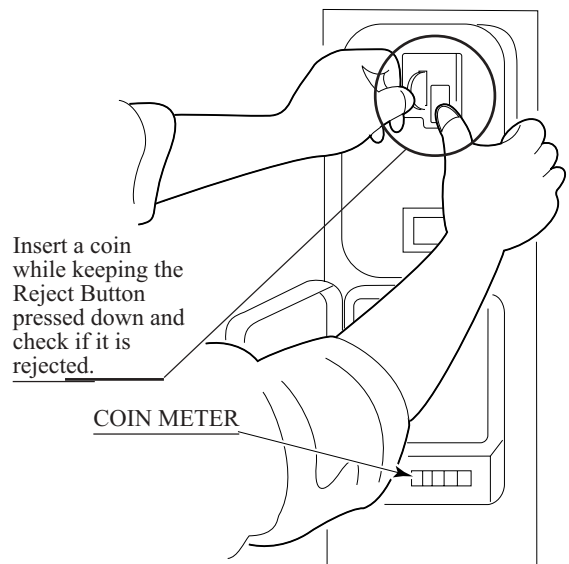

FIG. 13 c



WELLS-GARDNER  
ELECTRONICS CORPORATION  
2701 N. KILDARE CHICAGO, IL 60639  
1-800-336-6630

WWW.WGEC.COM

WGD15-2110-01

OVER/UNDER MINI DOOR  
2 ENTRIES WITH BILL  
VALIDATOR BOTTOM DOOR  
& SPECIAL ENCLOSURE

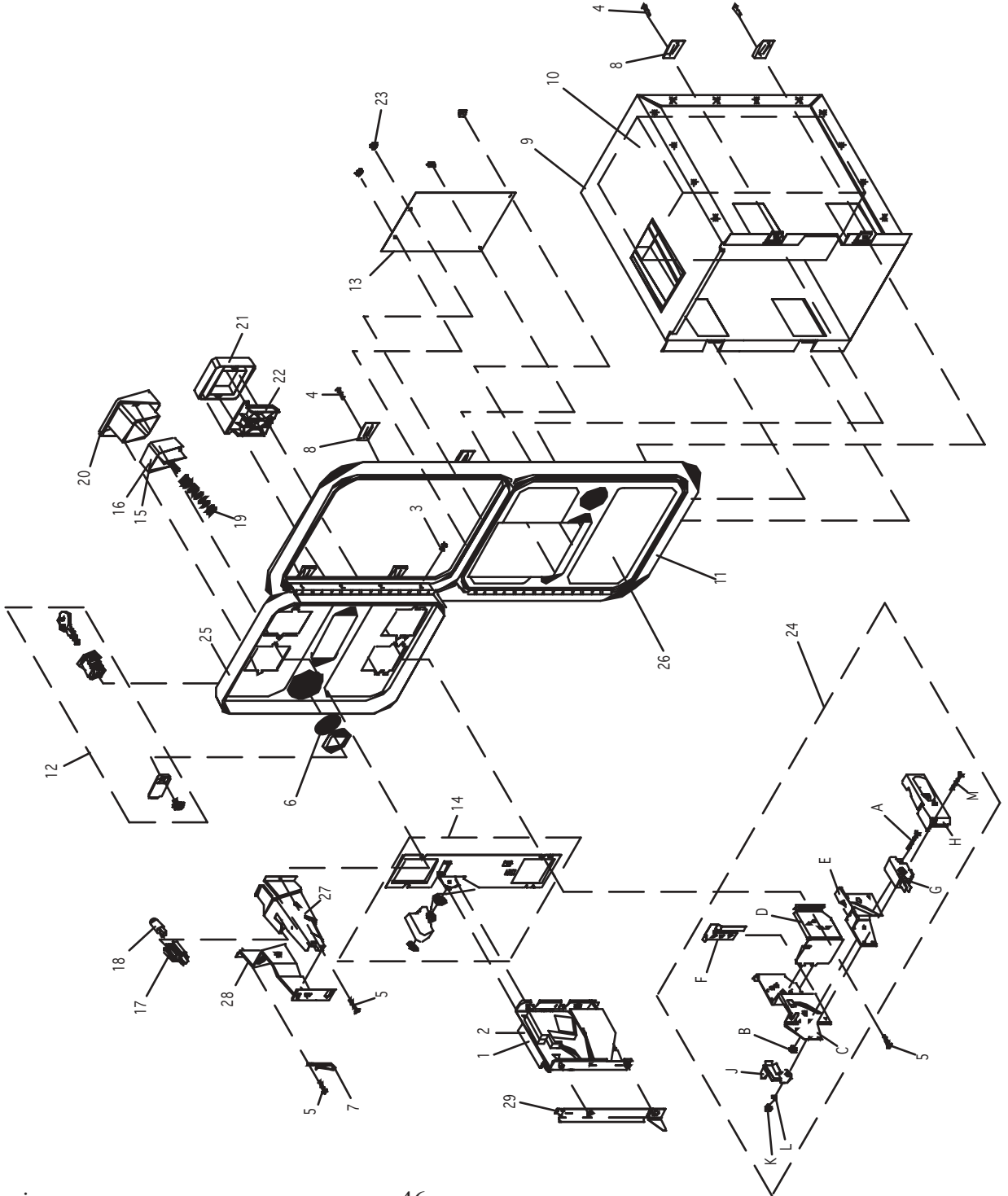

#	W.G. PART #	DESCRIPTION
1	812-4150-011	S-7 US 25c COIN MECH LEFT
2	812-4050-011	S-10 US \$1 COIN MECH RIGHT
3	890-1002-00	HINGE SCREW
4	890-1003-00	CLAMP SCREW
5	890-1017-00	SCREW TRILOBULAR
6	890-1019-00	WASHER INTERNAL TOOTH 3/4"
7	890-1300-00	KEYHOOK
8	891-0514-00	CLAMP UK 5/8" CABINET
9	025X3711-001	ENCLOSURE W/CHUTE
10	025X3712-001	METAL CASHBOX
11	891-0509-162	DOUBLE FRAME
12	891-0547-00	LOCK SINGLE BIT
13	891-0100-4016	COVER PLATE
14	891-1008-107	BASE PLATE ASSEMBLY
15	891-1113-03	E/R BUTTON US 4x25c/\$1 LEFT
16	891-1113-011	E/R BUTTON US \$1 COIN RIGHT
17	891-1117-00	LAMPHOLDER
18	891-1118-00	LAMP WEDGE BASE 6 VOLT
19	891-1121-00	SPRING, E/R BUTTON
20	891-1311-16	BUTTON BEZEL, NYLON
21	891-1312-16	REJECT BEZEL, NYLON
22	891-1109-16	REJECT FLAP
23	020X1877-005	NUTKERS #8-32 X 5/16 HEX
24	891-2216-16	MICROSWITCH ASSEMBLY
24A	890-1007-00	SCREW, FLAT HEAD M/S
24B	890-1206-02	KEP NUT
24C	891-1105-01	REJECT CUP SIDE PLATE
24D	891-1106-00	REJECT CUP BASE PLATE
24E	891-1107-00	BRACKET, MICROSWITCH
24F	891-1110-00	ADJUSTER, COIN
24G	891-1116-16	MICROSWITCH, BLACK - MED.
24H	891-1125-00	COVER, PLASTIC
24J	892-1002-07	CLIP, SNAP-ON
24K	892-1002-08	ELASTIC SNAP NUT
24L	892-1002-09	SLEEVE, SNAP-ON
24M	892-1002-11	SCREW, PAN HEAD
25	891-0604-16	MINI DOOR 2 ENTRIES
26	891-0614-16	MINI DOOR W/OBV C/O
27	892-1002-01	BRACKET, LAMP SIDE
28	892-1002-021	BRACKET, COVERSIDE
29	892-1002-10	BRACKET, HOLD DOWN

Tom Happ  
 tom.happ@happcontrols.com  
 Happ Controls, 106 Garlich Drive, Elk Grove, IL 60007  
 Visit our website <http://www.happcontrols.com>

Ph: 847-593-6161 ext. 107  
 Fx: 847-956-2091

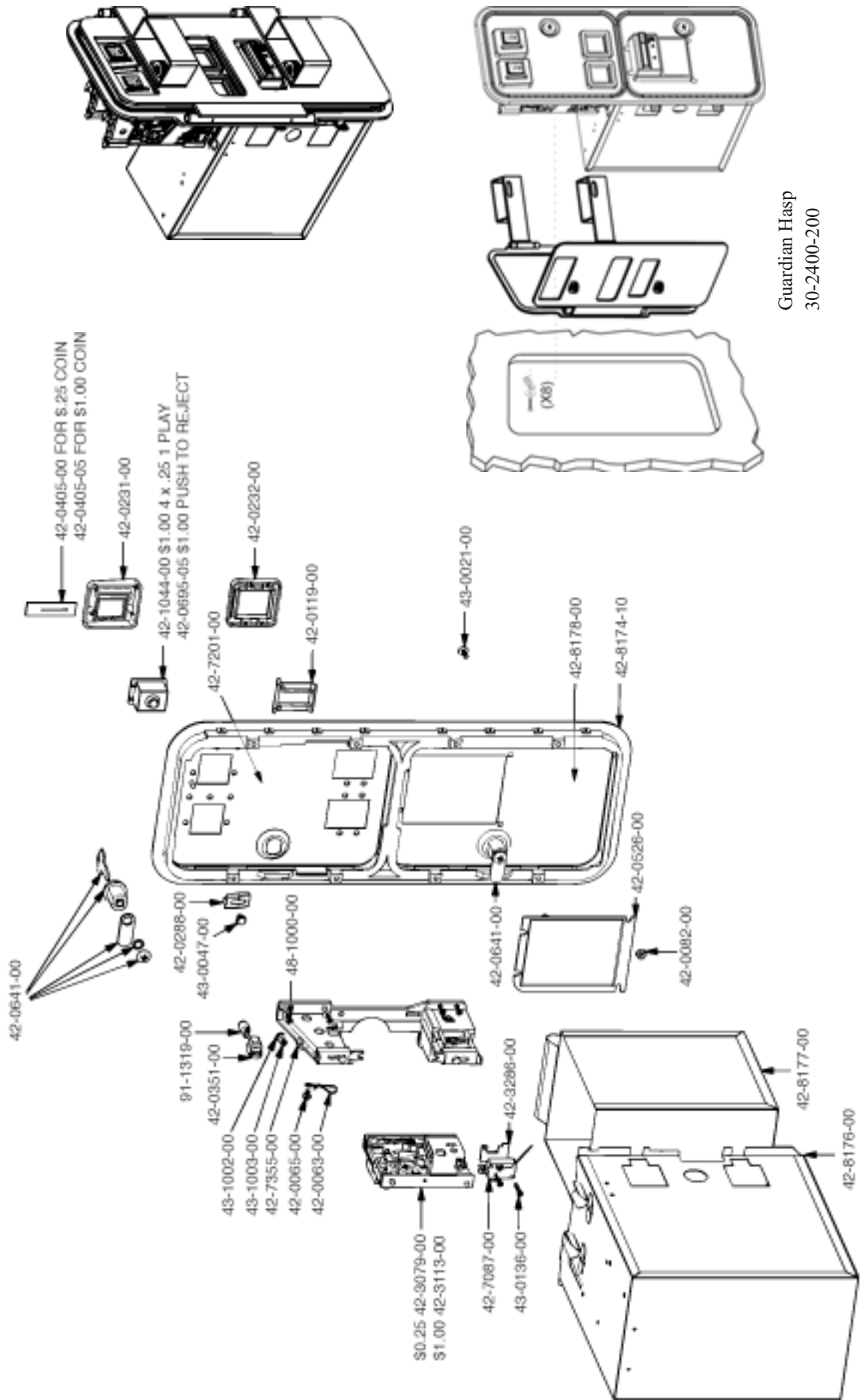

Guardian Hasp  
 30-2400-200

## OPTIONAL DOLLAR BILL ACCEPTOR

- THE COIN DOOR ASSEMBLY USED ON **F355 challenge DX TYPE** COMES EQUIPPED TO ACCEPT A DOLLAR BILL ACCEPTOR. ALL NEEDED WIRING CONNECTIONS ARE CONVENIENTLY LOCATED INSIDE THE GAME FOR THIS APPLICATION.
- THE COIN DOOR CAN ACCCOMMODATE THE FOLLOWING VALIDATOR(S):

FORWARD-MOST  
HOLE POSITION

Mars 2000 series

\*\*42-1155-00            MARS VALIDATOR \$1, 2, 5 300 CAP

The frame and cashbox enclosure on this coindoor has been modified to accomodate a Mars 2000 series upstacker. A 2000 series stacker can be added by simply removing the cut-out plate. This one entry door can be ordered through Happ Controls or one of Happ Controls authorized distributors. The part number is 40-6000-10EX. The Mars stacker can be obtained through an authorized Mars distributor.

Note: Your game may have either Happ Controls Coin Door Assembly or the Wells Gardner Coin Door Assembly (not shown).

\*\*Happ part number

Security Locking Bar/Bracket Set Part No.# 999-0966

Modified Cash Box (For use when DBA installed)  
Part No. # 999-1106

Plastic Cash Box - Full Size Part No. # 999-1177

# 14. MONITOR

## 14 - 1 CAUTIONS AND WARNINGS CONCERNING THE SAFETY FOR HANDLING THE MONITORS

Before handling the monitors, be sure to read the following explanations and comply with the caution/warning instructions given below. Note that the caution/warning symbol marks and letters are used in the instructions.



Indicates that handling the monitors erroneously by disregarding this warning may cause a potentially hazardous situation, which could result in death or serious injury.



Indicates that handling the monitors by disregarding this caution may cause a potentially hazardous situation, which could result in personal injury and or material damage.



Indicates that access to a specific part of the equipment is forbidden.



Indicates the instruction to disconnect a power connector or to unplug.



- When performing such work as installing and removing the monitor, inserting and disconnecting the external connectors to and from monitor interior and the monitor, be sure to disconnect the power connector (plug) before starting the work. Proceeding the work without following this instruction can cause electric shock or malfunctioning.
- Using the monitor by converting it without obtaining a prior permission is not allowed. SEGA shall not be liable for any malfunctioning and accident caused by said conversion.



### Primary side and Secondary side

The monitor's circuit which is divided into the Primary side and Secondary side, is electrically isolated. Do not touch the primary side, or do not touch both the primary side and the secondary side simultaneously. Failing to observe the instruction can cause electric shock and this is very dangerous. When making monitor adjustments, use a non-conductive driver and make adjustment without touching any part other than the Adjustment V. R. and knob. Also, be sure not to cause a short-circuit to the Primary side and Secondary side. If short-circuited, it can cause electric shock or malfunctioning, which is very dangerous.

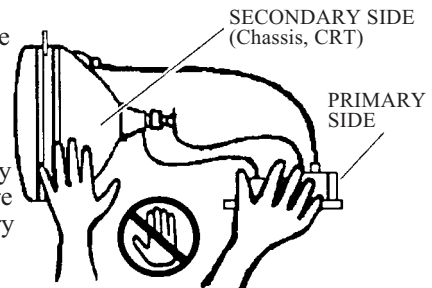

### High-tension Voltage

Some of the parts inside monitor are subject to high-tension voltage in excess of 20,000 volts and very dangerous. Therefore, do not touch the monitor interior. Should soldering & paper wastes, etc. be mixed in the monitor interior, turn the power off so as not to cause malfunctioning or fire hazard.

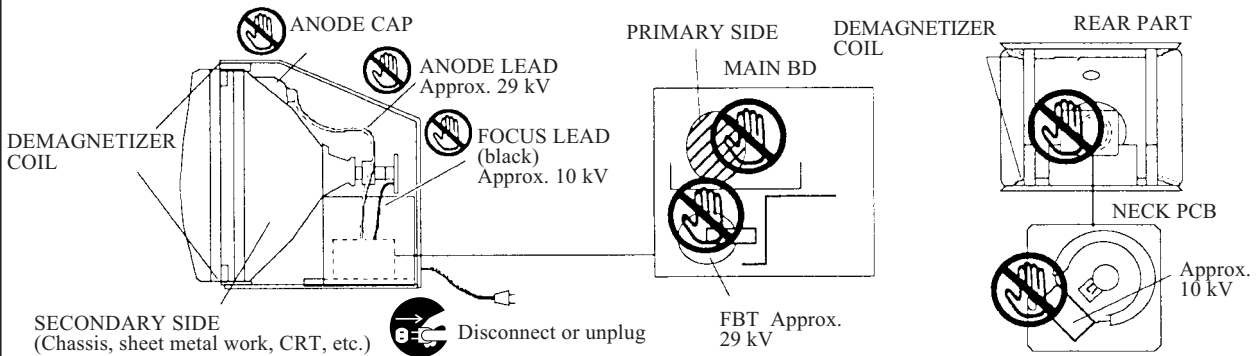

### Connecting the CRT and PCB

For combining the CRT and PCB, use the specified part No. to maintain the status of adjustments made at the factory. The anode of the CRT itself will be accumulatively charged as time elapses, generating high-tension voltage which is very dangerous. The monitor should be used with the Chassis, CRT and PCB assembled. When repair, etc. is required at the time of malfunctioning, be sure to send it in an "as is assembled" condition. If these are disassembled, what's charged to said high tension voltage can be discharged, causing a very hazardous situation. Therefore, under no circumstances should it be disassembled.



**CAUTION!**

- **Static Electricity**

Touching the CRT surface sometimes causes you to slightly feel electricity. This is because the CRT surfaces are subject to static and will not adversely affect the human body.

- **Installation and removal**

Ensure that the Magnetizer Coil, FBT (Fly-Back Transformer), Anode Lead and Focus Lead are not positioned close to the sheet metal work's sharp edges, etc. and avoid damaging the insulated portions so as not to cause electric shock and malfunctioning. (For the name of parts, refer to the above Figures).



For the purpose of static prevention, special coating is applied to the CRT face of this product. To protect the coating, pay attention to the following points. Damaging the coating film can cause electric shock to the customers.

- Do not apply or rub with a hard item (a rod with pointed edge, pen, etc.) to or on the CRT surfaces.
- Avoid applying stickers, seals, etc. on the CRT face.
- Do not remove aluminum foils from the CRT corners. Removing the aluminum foils can cause static prevention effects to be lowered.

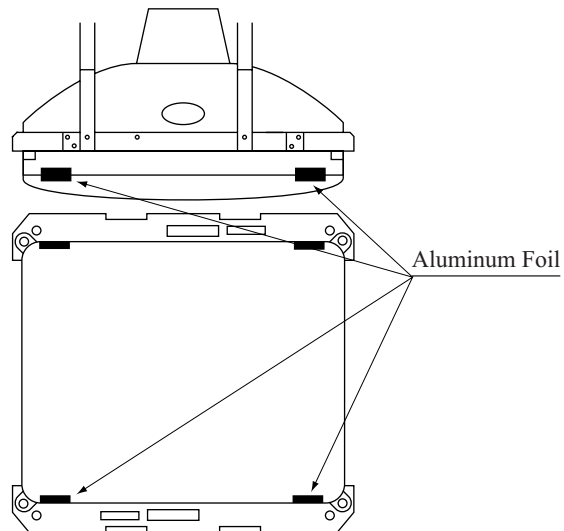

#### 14 - 2 CAUTIONS TO BE HEDED WHEN CLEANING THE CRT SURFACES



Static preventive coating is applied to the CRT surfaces. When cleaning, pay attention to the following points. Peeling off of static preventive coat can cause electric shock.

- Remove smears by using a dry, soft cloth (flannels, etc.). Do not use a coarse gauze, etc.
- For smear removing solvent, alcohol (ethanol) is recommended. When using chemical detergent, be sure to follow instructions below:
  - Dilute chemical detergent with water and dip a soft cloth in and then thoroughly wring it to wipe smears off.
  - Do not use a chemical detergent containing an abradant, powder or bleaching agent.
  - Do not use alkaline chemical detergents such as "glass cleaner" available on the market or solvents such as thinner, etc.
- Do not rub or scratch the CRT face with hard items such as brushes, scrub brush, etc.

Clean the CRT surfaces once a week. When cleaning, pay attention to the above caution so that the antistatic coating will not come off.

14 - 3 ADJUSTMENT METHOD



- Monitor adjustments have been made at the time of shipment. Therefore, do not make further adjustment without a justifiable reason. Adjusting the monitor which contains high tension parts is a dangerous work. Also, an erroneous adjustment can cause deviated synchronization and image fault, resulting in malfunctioning.
- When making adjustment, utilize a resinous Alignment Rod. Servicing with bare hand or using conductive tools can cause electric shock.

Remove the 2 screws from the Monitor Board Lid on top of the monitor, and the Adjustment Board appears.

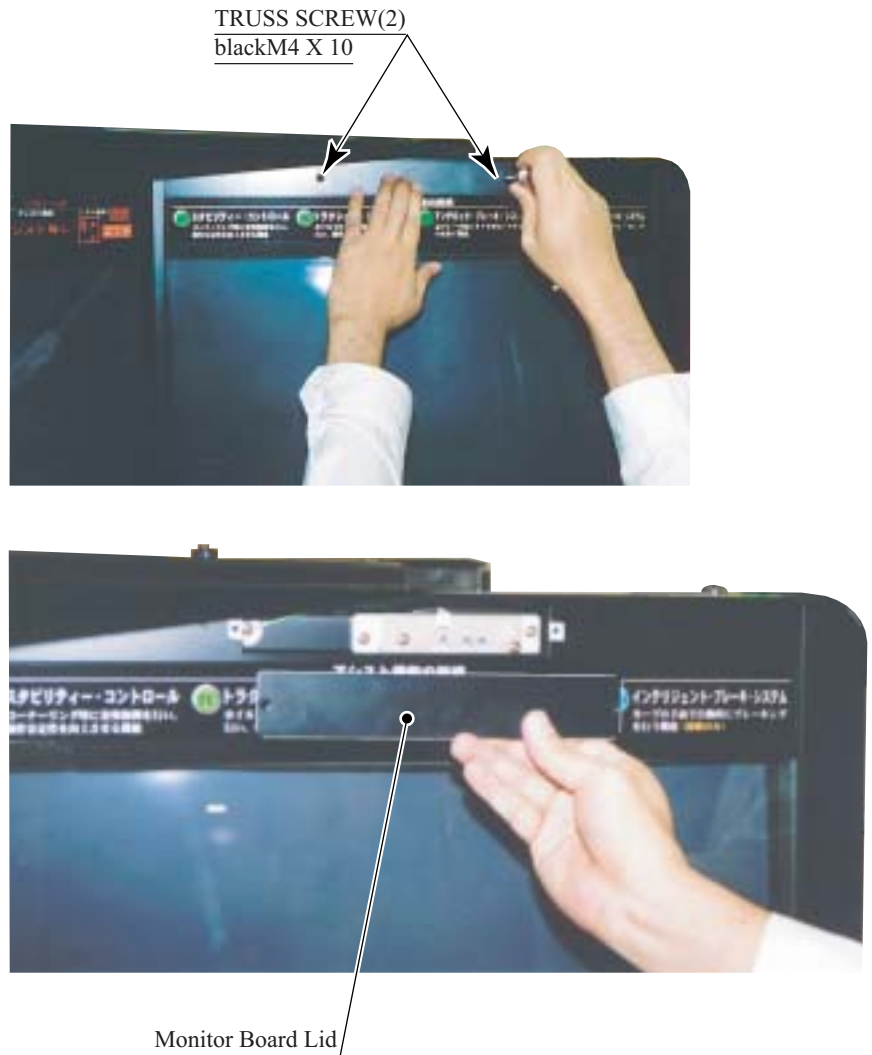
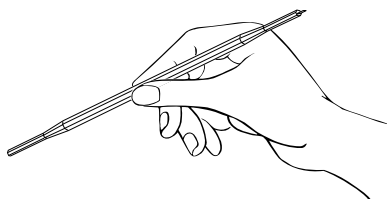

PHOTO 14. 3



For adjustment, use the Resinous Adjustment Rod.

FIG. 14. 3

## OPERATION

- ① Press the MODE button to display OSD. The right-hand end numeral indicates INPUT FREQUENCY.

Example: 31 kHz Input

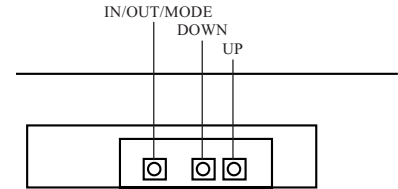
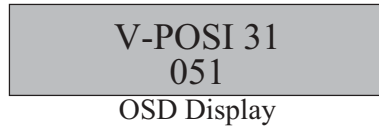

- ② Press the MODE button to select the adjustment item.  
(Each time the MODE button is pressed, the OSD display shifts sequentially in order of V-POSI → H-POSI → V-SIZE → H-SIZE → CONTRAST → BRIGHT → DEGAUSS → RESET → OSD display disappears.)  
Press the DOWN button while pressing the MODE button to return the adjustment item to the preceding one.

- ③ Adjust with UP button and DOWN button.

- ④ To exit from OSD, keep pressing the MODE button until the OSD display disappears.

- V-POSI  
The image's vertical position is adjustable.

V-POSI

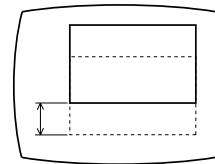

H-POSI

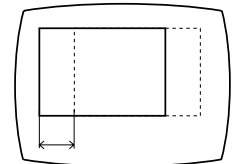

- H-POSI  
The horizontal image's position is adjustable.

- V-SIZE  
The vertical image size is adjustable.

V-SIZE

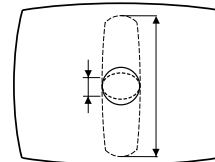

H-SIZE

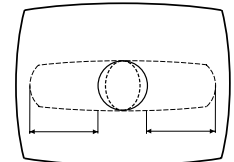

- H-SIZE  
The horizontal image size is adjustable.

- CONTRAST  
Adjusts image contrast.

- BRIGHT  
This adjusts the on-screen image brightness.

- DEGAUSS  
Degaussing is performed. Once degaussed, it takes approximately 4 minutes and 30 seconds to have degaussing function again. Wait until the lower OSD display indicates PLEASE.

- RESET  
Reset the on-screen setting status to the factory setting. (Press the UP button or DOWN button for one second or longer.) Note that the factory setting status is predetermined and not changeable.



## 14 - 4 CLEANING THE MONITOR GLASS

Removing the Monitor Glass requires complicated work. Clean the Front Glass only in the weekly cleaning. To clean the Reverse Glass of the Monitor and the CRT Surface, removing the Monitor Glass is required.

### FRONT MONITOR GLASS

- ① Take out 2 screws to remove the Boss Cover.
- ② Take out 10 screws to remove the Control Panel Upper. If it is hard to take out the screws due to the existence of the Steering Wheel, remove the emblem and the Steering Wheel ahead of time.
- ③ Take out 4 screws to remove the Control Panel Bracket Upper.
- ④ Take out a total of 6 screws, and remove each of Glass Holder Upper Center, Glass Holder Upper Lower, and Glass Sash.

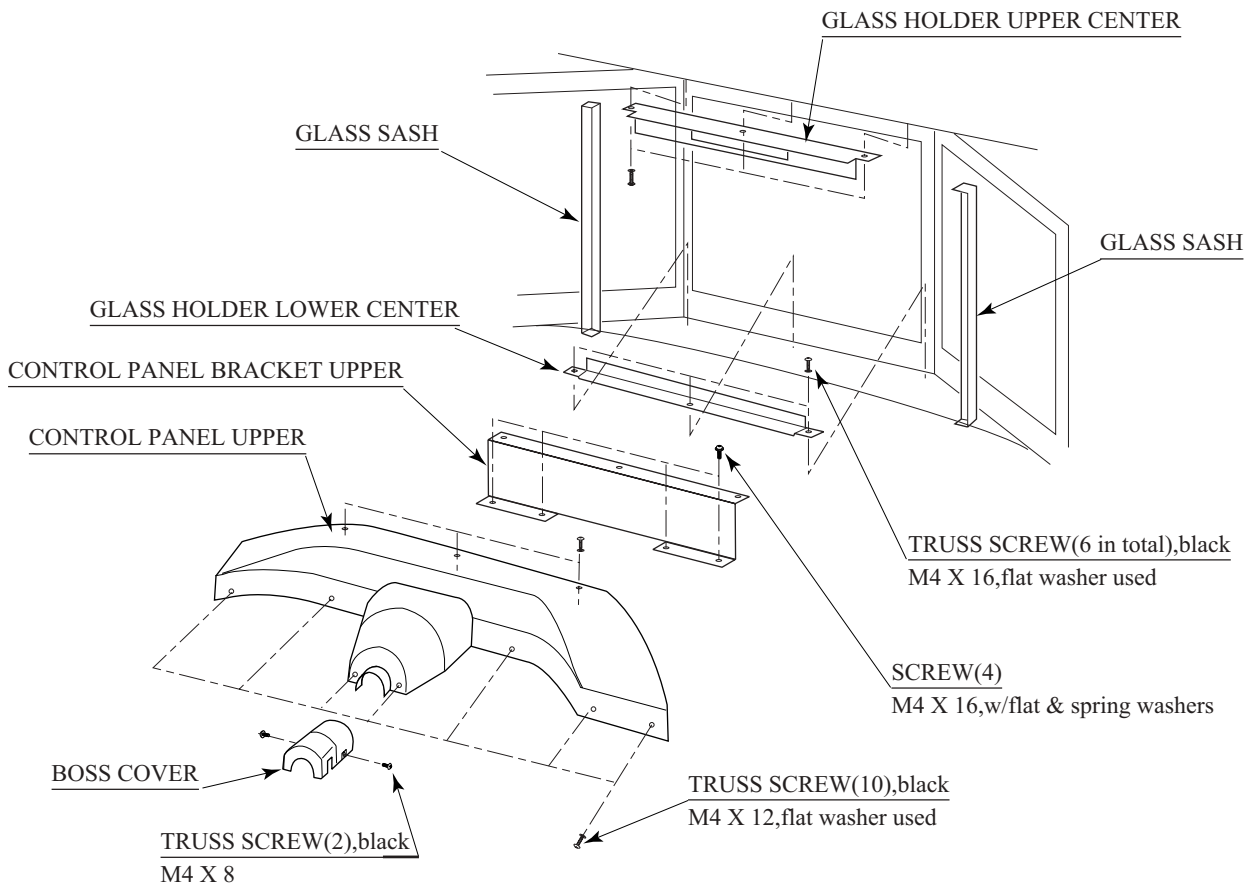

- ⑤ Take out the Monitor Glass.

FIG 14. 4 b

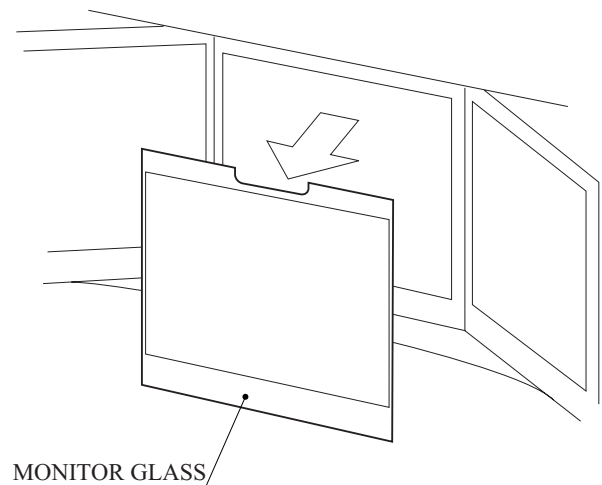

**BOTH SIDE MONITOR GLASS**

① Take out 9 screws and remove Monitor Cover.



PHOTO 14. 4 a

② Take out 3 screws and remove Monitor Side Cover.



PHOTO 14. 4 b

- ③ Take out 2 screws to remove the Side Cover Bracket.

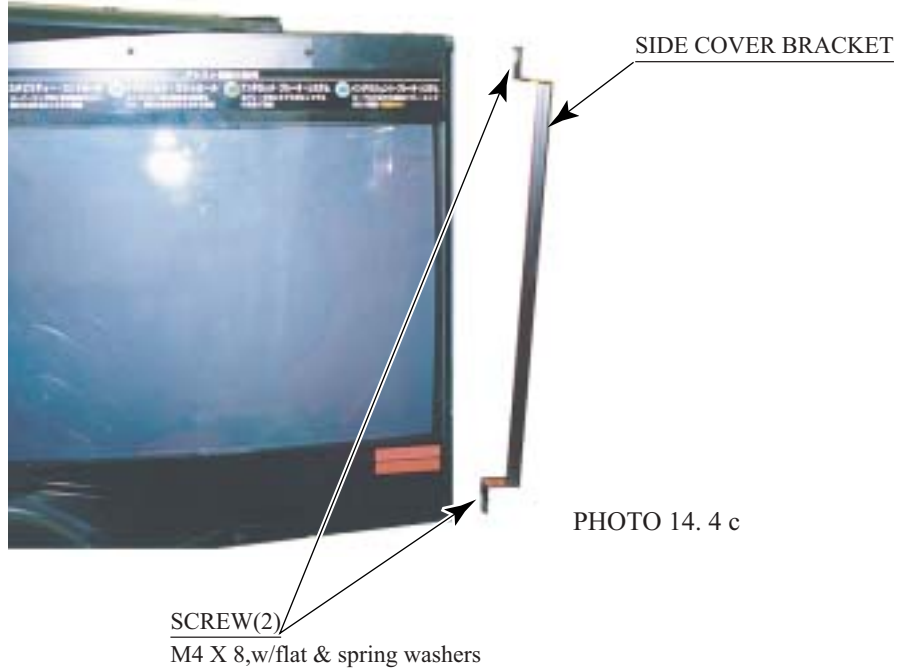

- ④ Take out 2 screw to remove the Monitor Board Lid.

- ⑤ Pull out the Monitor Glass.



PHOTO 14. 4 d

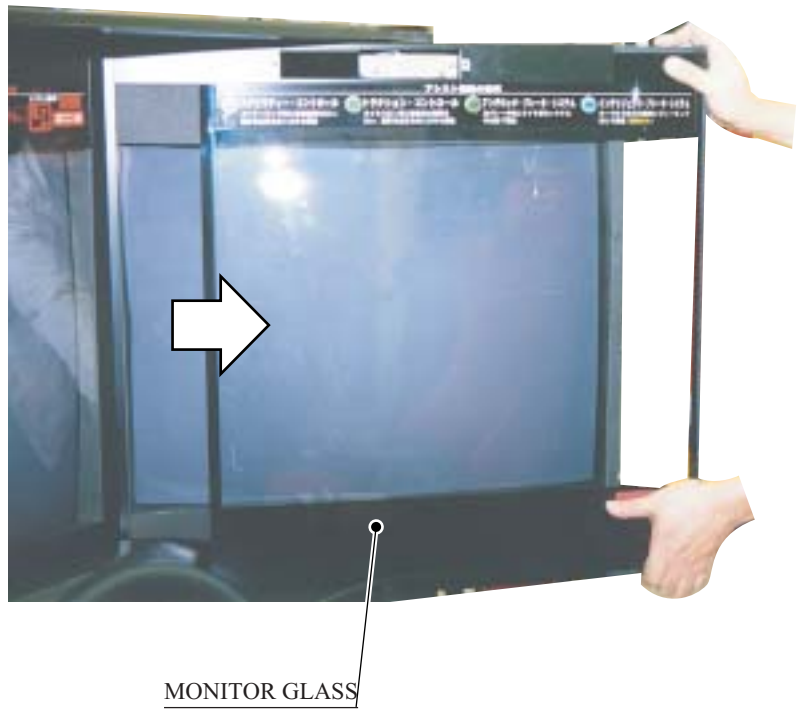

## 15. REPLACING THE FLUORESCENT LAMP, AND LAMPS

The Error Lamp is used when the Printer (optional) is incorporated. If the Printer (optional) is not incorporated, disregard the following explanation of replacing the ERROR LAMP.

Regarding the U.S. Specifications:

The parts employed for the U.S. Specifications machines are procured in the U.S.A. Therefore, the parts in the U.S. Specifications are different from those of described in this section or listed in the PARTS LIST. When replacing the Fluorescent Lamp, be sure to contact where you purchased the product from.



WARNING!

- When performing work, be sure to turn power off. Working with power on can cause electric shock and short circuit hazards.
- The Fluorescent Lamp, when it gets hot, can cause burn. Be very careful when replacing the Fluorescent Lamp.
- Be sure to use lamps of the designated rating. Using lamps of undesignated rating can cause a fire or malfunctioning.



CAUTION!

- To perform work safely and securely, be sure to prepare a step which is in a secure and stable condition. Performing work without using the step can cause violent falling down accidents.
- When handling glass-made or plastic parts, use care. Failure to observe this may damage parts and cause injury due to fragments resulting from damage.

This product employs the total of 4 fluorescent lamps and the total of 2 slim lamps (no-electrode lamps).

## SEAT LEFT & RIGHT

- ① Turn off power.
- ② Take out 5 Truss screws from the left-hand side and 4 Truss screws from the right-hand side of the seat facing the monitor.
- ③ Remove the Sash.
- ④ Remove the FL Cover Side.
- ⑤ Replace the Fluorescent Lamp.

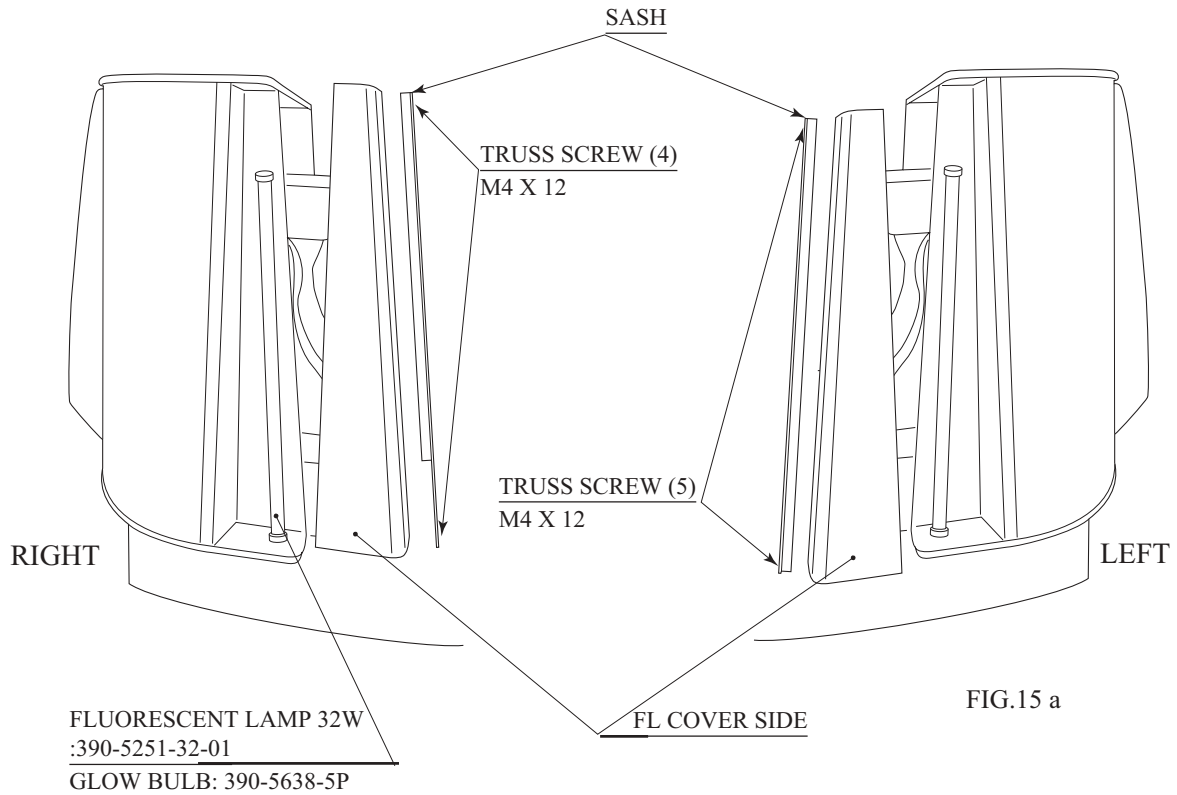

**BILLBOARD**

- ① Turn off power.
- ② Take out 4 Truss screws in total.
- ③ Remove 2 Bushes and the Plate Holder.
- ④ Remove the FL Plate. At this time, be sure to keep the washers used underneath the Bushes.
- ⑤ Replace the Fluorescent Lamp.

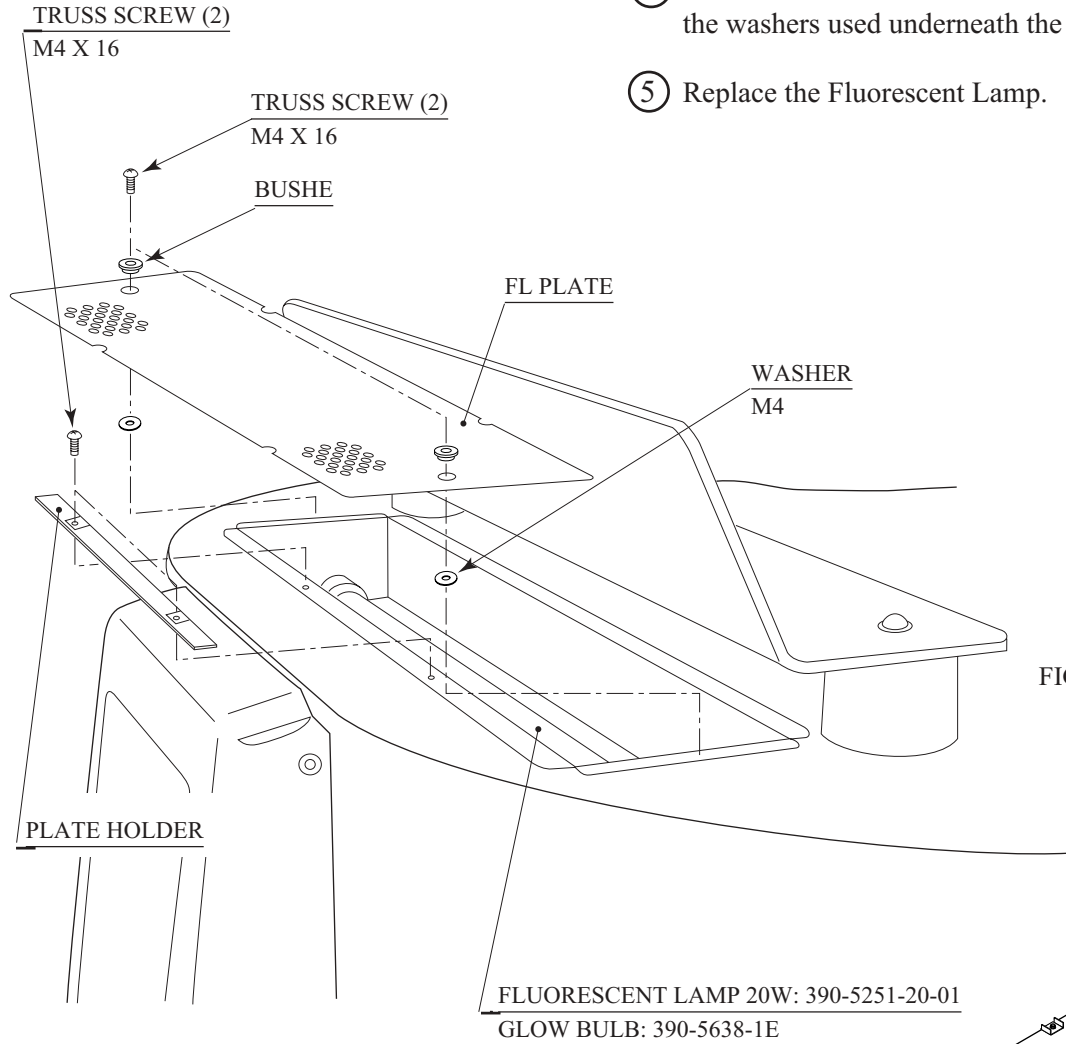
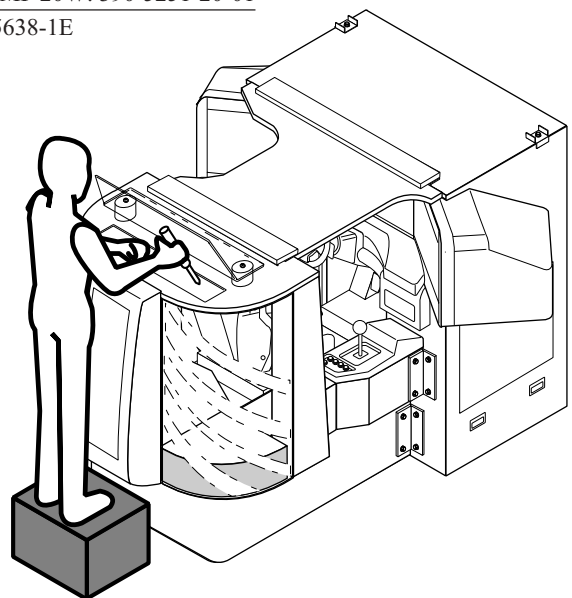

FIG. 15 b

When performing work, be sure to use a step.



THE REAR SIDE

- ① Turn off power.
- ② Take out 8 Truss screws.

TRUSS (8)M4 X 12,flat washer used.

- ③ Remove the FL Cover Rear.
- ④ Replace the Fluorescent Lamp.

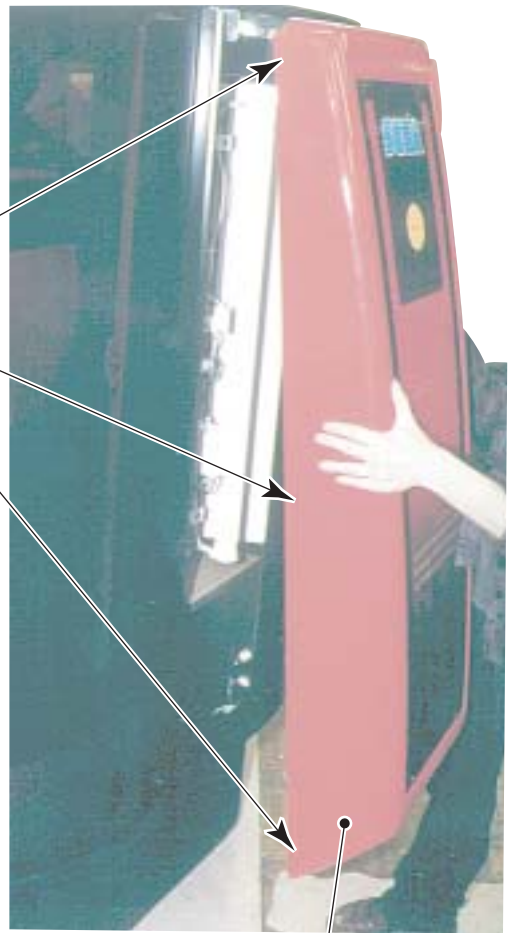

PHOTO 15 a

FL COVER REAR

FLUORESCENT LAMP 30W: 390-5251-30-01  
GLOW BULB: 390-5638-1E



PHOTO 15 b



**SLIM LAMP**

- ① Remove the FL Cover Rear as per procedures in THE REAR.
- ② Take out 4 screws of the FL Cover Rear installing portion where the Slim lamp to be replaced is attached.

SCREW (4)M4 X 16,w/flat & spring washers

- ③ Remove the Sash Rear.

- ④ Take out 2 screws.

- ⑤ Remove the Rear Window.



PHOTO 15 c

TRUSS SCREW (2)  
M4 X 12

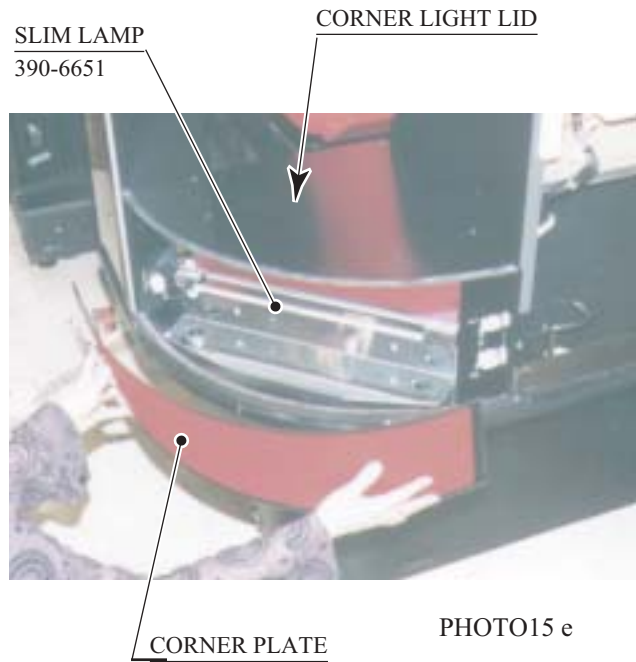

PHOTO 15 d

REAR WINDOW



- ⑥ Remove the Corner Plate. When it is hard to remove the Corner Plate, loosen the 5 screws which secure the Corner Light Lid.



- ⑦ Take out 2 screws which secure the Bracket of connector side of the Slim lamp.
- ⑧ Disconnect the connector and replace the Slim lamp.
- ⑨ Insert the edge of the replacing Slim lamp in to the holder.
- ⑩ Pass the plastic made bush and spacer through the 2 screws which secure the Bracket of the connector side. Install in a manner to put the installation portion between the bush and the spacer.

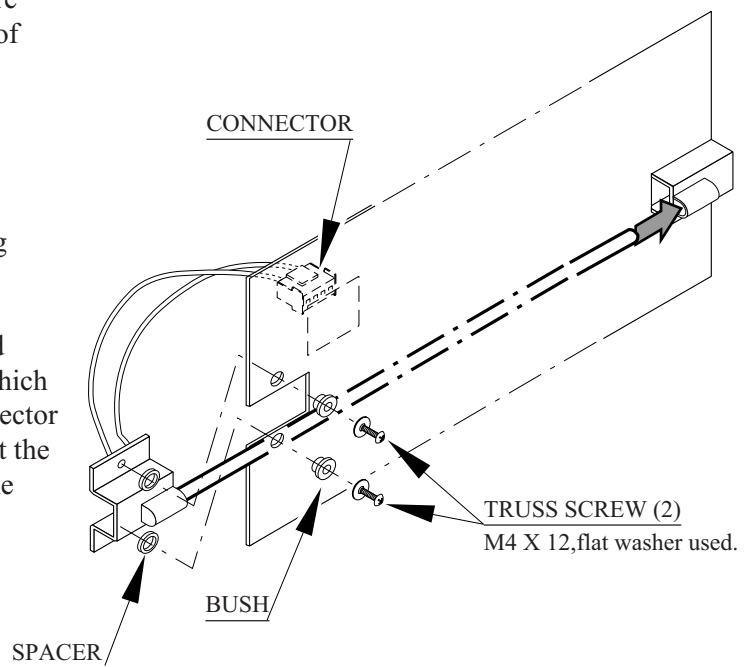
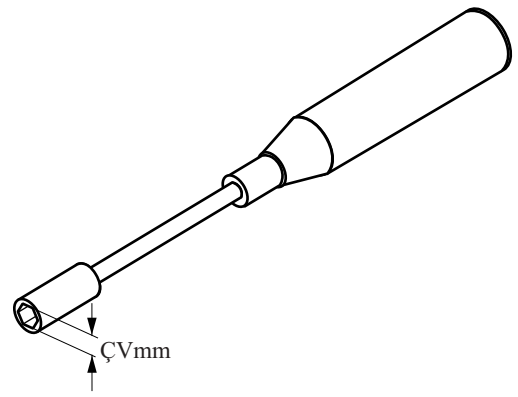

FIG. 15 c

## ERROR LAMP

To perform the following work, a Phillips type Screwdriver and a driver for M4 Hexagon Nut are required.



- ① Turn off power.
- ② Take out 2 screws.
- ③ Remove the Socket Cover.

SCREW (2)  
M4 X 8

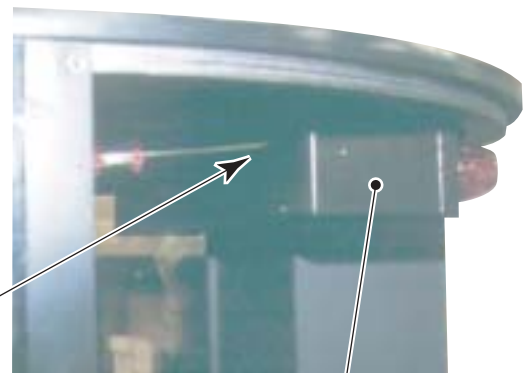

SOCKET COVER

PHOTO 15 f

- ④ Disconnect a connector.

Disconnect the connector



PHOTO 15 g

- ⑤ Take out 2 Flange Nuts.
- ⑥ Remove the Lamp together with the Lamp Base.

FLANGE NUT (2)  
M4

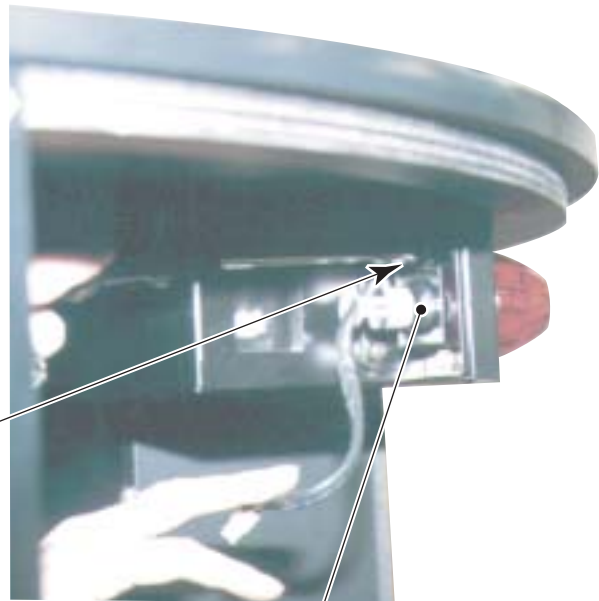

LAMP BASE

PHOTO 15 h

- ⑦ Replace the Lamp.

LAMP 110V 10W  
390-5174

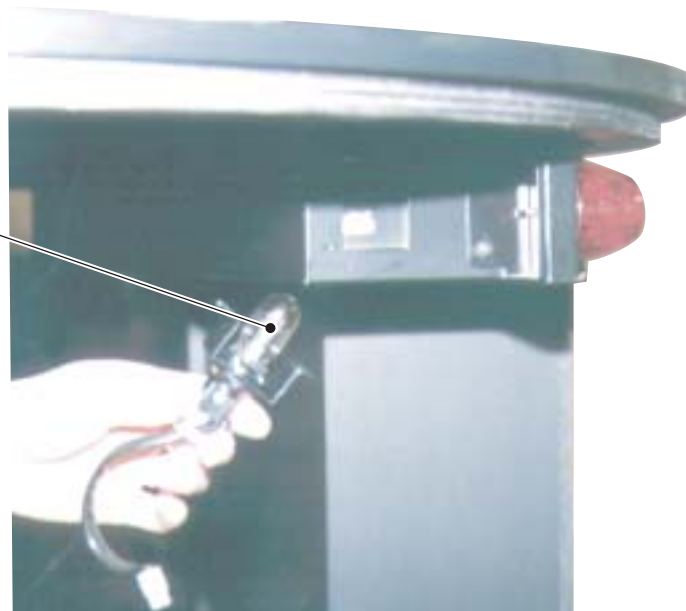

PHOTO 15 i

## REPLACING THE EFFECT SWITCH LAMP

- ① Remove the Shift Cover as per procedures 10-1.

Unlock the lock

- ② A metallic part is ejected from the switch base of the EFFECT SWITCH reverse side. Turning the metallic part can unlock the lock. Take off the wiring connecting portion from the switch.

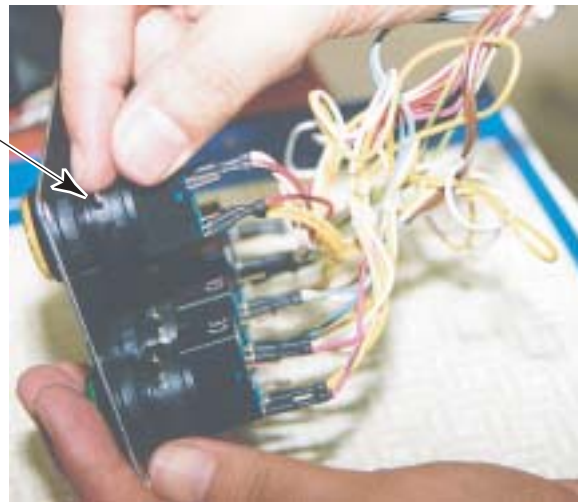

PHOTO 15 j

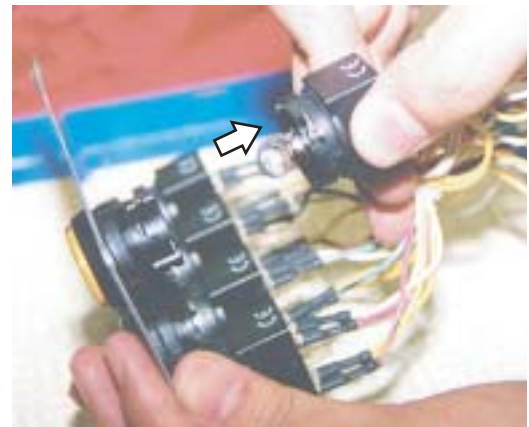

PHOTO 15 k

- ③ The lamp is inside the wiring connecting portion. Push and then turn the Lamp counterclockwise to remove.

LAMP 6.3V 1W  
390-5445-01



PHOTO 15 l

## 16. PERIODIC INSPECTION TABLE

The items listed below require periodic check and maintenance to retain the performance of this machine and to ensure safe business operation.



- Be sure to check once a year to see if Power Cords are damaged, the plug is securely inserted, dust is accumulated between the Socket Outlet and the Power Plug, etc. Using the product with dust as is accumulated can cause fire and electric shock hazards.
- Periodically once a year, request the place of contact herein stated or the Distributor, etc. where the product was purchased from, as regards the internal cleaning. Using the product with dust as is accumulated in the interior without cleaning can cause a fire or accident. Note that cleaning the interior parts can be performed on a pay-basis.

TABLE 16

ITEMS	DESCRIPTION	PERIOD	REFERENCE
CABINET	Check Adjusters' contact with surface.	Daily	3
HANDLE MECHA	Check VOLUME VALUE.	Monthly	SERVICE MANUAL
	Gear part greasing	Tri-monthly	9-2
PADDLE SHIFT	Check SW.	Monthly	SERVICE MANUAL
ACCEL. & BRAKE	Check VOLUME VALUE.	Monthly	SERVICE MANUAL
	Gear and Spring portion greasing	Tri-monthly	11-2
CLUTCH PEDAL	Check VOLUME VALUE.	Monthly	SERVICE MANUAL
6-SPEED SHIFT	Check SW.	Monthly	SERVICE MANUAL
	Greasing	Tri-monthly	12
PRINTER (OPTIONAL)	Cleaning of the printer head	After a roll of paper is exhausted.	7
COIN SELECTOR	Check COIN SWes.	Monthly	SERVICE MANUAL
	Coin insertion test.	Monthly	13
	COIN SELECTOR cleaning.	Tri-monthly	13
MONITOR	Check adjustments.	Monthly	SERVICE MANUAL
	MONITOR GLASS cleaning.	Weekly	14-4
GAME BD	MEMORY TEST.	Monthly	SERVICE MANUAL
	Check settings.	Monthly	SERVICE MANUAL
REAR CABINET	Grease the Seat Rail portion.	Trimonthly	See next page (FIG. 16).
Cabinet surfaces	Cleaning	As necessary.	See next page.
INTERIOR	Cleaning	Annually	See above.
POWER SUPPLY PLUG	Inspection and cleaning		

### REAR CABINET (Greasing to Seat Rail Portion)

Move the Seat to the rearmost portion and apply spray greasing to the portion shown at the right once every 3 months by using NOK KLUBER L60 or GREASE MATE SEGA PART No. 090-0066.

After greasing, move the Seat a few times forward and backward so as to allow the grease to be applied all over uniformly. Be sure to wipe grease which attaches to the surfaces of the PROTECT RUBBER on the Seat Rail, or any excess grease.

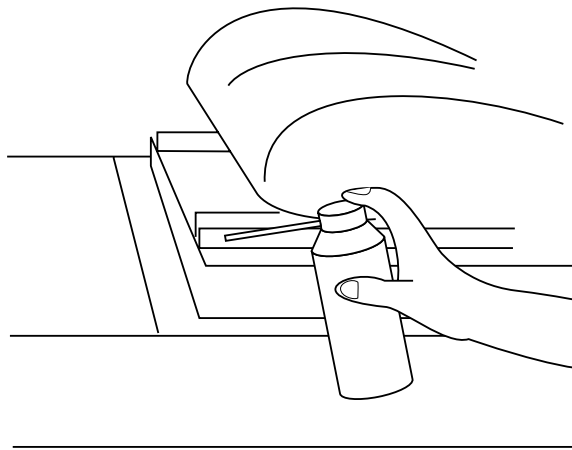

FIG. 16

### CLEANING THE CABINET SURFACES

If the Cabinet is badly stained, use a cloth which is dipped in the chemical detergent liquid diluted with water and then squeezed dry. Do not use such solvents as alcohol, thinner, benzine, etc., or abrasives, bleaching agents and or chemical dustcloth as these can damage cabinet surface finish.



# 17. TROUBLESHOOTING

In case a problem occurs, first check wiring connector connections.



- In order to prevent electric shock and short circuit, be sure to turn power off before performing work.
- Be careful so as not to damage wirings. Damaged wiring can cause electric shock or short circuit.
- After removing the cause of the functioning of the Circuit Protector, reinstate the Circuit Protector. Depending on the cause of the functioning, using the Circuit Protector as is without removing the cause can cause generation of heat and fire hazard.

TABLE 17 a

PROBLEMS	CAUSE	COUNTERMEASURES
When the main SW is turned ON, the machine is not activated.	The power is not ON.	Firmly insert the plug into the outlet.
	Incorrect power source/voltage.	Make sure that the power supply/voltage are correct.
	AC UNIT CIRCUIT PROTECTOR functioned due to instantaneous overcurrent.	First, remove the cause of overcurrent and reinstate the circuit protector to its original status. (see Sec. 6)
	CIRCUIT PROTECTOR inside the Cabinet functioned due to instantaneous overcurrent.	Reinstate the circuit protector to its original status. (see FIG. 17 b)
The color of image on MONITOR screen is incorrect.	Incorrect monitor adjustment.	Make appropriate adjustments. (see Sec. 14)
The on-screen image of the monitor sways and or shrinks.	The power source and voltage are not correct.	Make sure that the power supply and voltage are correct.
Sound is not emitted.	Sound volume adjustment is not correct.	Adjust the SWITCH UNIT's sound adjustment volume. (see Service Manual)
	Malfunctioning BD. and Amp.	Perform Sound Test to check it. (see Service Manual)
	Connector connection is incorrect.	Check connectors between the Front and the Rear Cabinets. (see Sec. 6)

CIRCUIT PROTECTOR

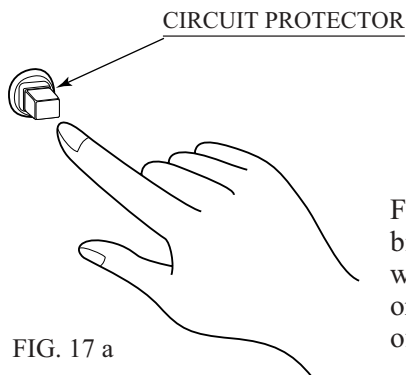

FIG. 17 a

Functions due to the activation of bimetal. To restore the function, wait for approximately one minute or longer until the bimetal cools off. (Press the Button.)

TABLE 17 b

PROBLEMS	CAUSE	COUNTERMEASURES
No sound is emitted from WOOFER.	The Fuse is blown due to momentary overload.	Replace fuse. (see FIG. 17 c) 514-5086-6300 FUSE 6.4A~30 6300mA 125W
Steering Wheel reaction strength is incorrect. Deviation of Center.	Power ON check not performed correctly.	Turn off power and then turn it back on again. Complete the power on check.
	V.R. position deviated.	Adjust V. R. value in the test mode. (see Service Manual)
	V.R. malfunctioning.	Replace V.R. (see Sec. 9)
Steering Wheel reaction strength is insufficient.	Reaction Mecha's secular change.	Adjust V. R. value in the Test mode. (see Service Manual)
Paddle Shift's operation is not satisfactory.	Switch malfunctioning.	Replace the Switch. (see 9-3)
6-speed Shift's operation is not satisfactory.	Switch malfunctioning.	Replace the Switch. (see Sec. 9)
Operation of Accel. and Brake Pedals are not satisfactory.	V.R. malfunctioning.	Replace the V.R. (see Sec. 11)
	ADJUST GEAR's engagement is not correct.	Adjust the engagement of ADJUST GEAR (see Sec. 11).
Crutch Pedal's operation is not satisfactory.	V.R. malfunctioning.	Replace the V.R. (see Sec. 12)
	ADJUST GEAR's engagement is not correct.	Adjust the engagement of ADJUST GEAR. (see Sec. 12)
Fluorescent lamp doesn't light up.	Fluorescent lamp needs replacement.	Replace the fluorescent lamp. (see Sec. 15)

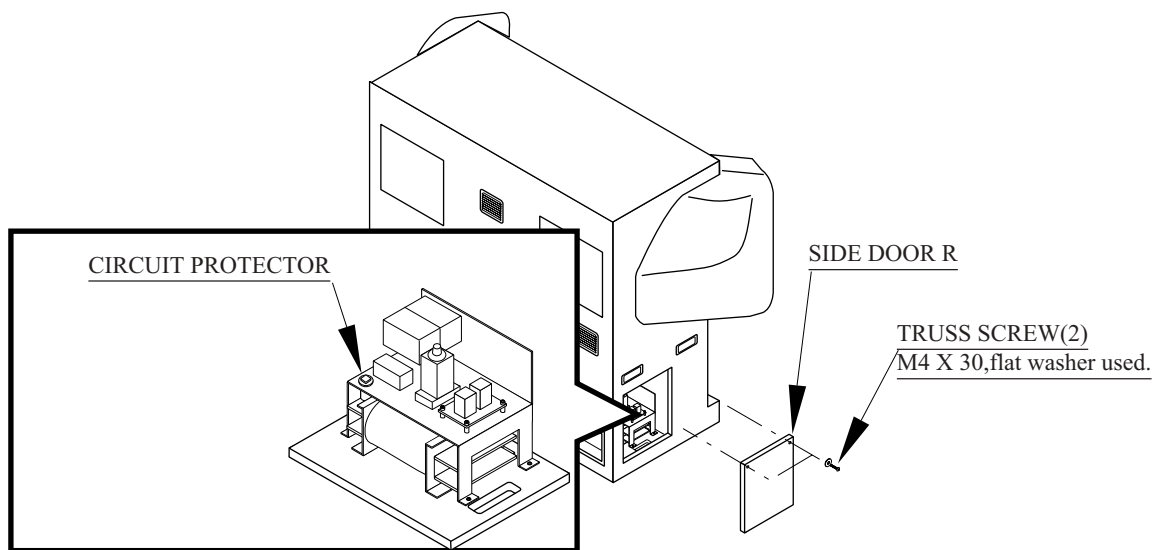

FIG. 17 b

## REPLACEMENT OF FUSE



WARNING!

- Fuse replacements other than those specified can cause accidents and are strictly forbidden. In case fuse replacements other than those stated in this manual are necessary, contact where you purchased the product from for inquiries regarding this matter.
- In order to prevent an electric shock, be sure to turn power off and unplug from the socket outlet before performing work by touching the internal parts of the product.
- Be careful so as not to damage wirings. Damaged wiring can cause electric shock and short circuit accidents.
- Be sure to use fuses meeting specified rating. Using fuses exceeding the specified rating can cause fire and electric shock accidents.
- After eliminating the cause of the blowing of fuse, replace the fuse. Depending on the cause of fuse blowing, continued use with the fuse as is blown can cause generation of heat and fire hazard.

Take out 2 screws to remove Side Door R, and the fuse appears as shown.

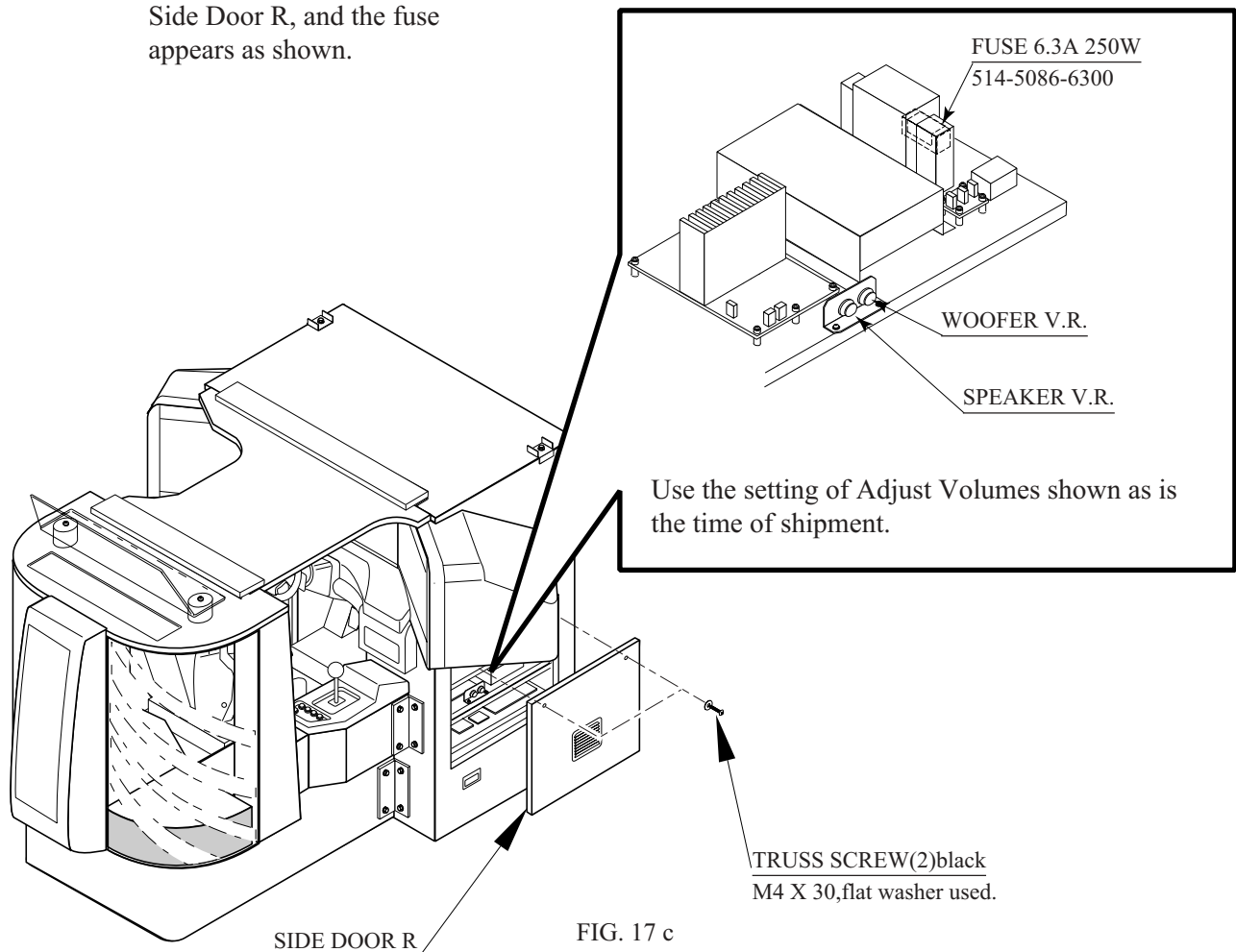

## 18. GAME BOARD



WARNING!

- In order to prevent electric shock and short circuit hazards, be sure to turn power off before performing work.
- Be careful so as not to damage wirings. Damaged wiring can cause fire, electric shock and short circuit hazards.
- Do not expose the Game BD, etc. without a good reason. Failure to observe this can cause electric shock or malfunctioning.



CAUTION!

The electronic parts on the IC Board could be damaged due to human body's static electricity. Before performing IC Board related work, be sure to discharge physically accumulated statics by touching grounded metallic surfaces, etc.



IMPORTANT!

Put the Game Board in the Carton Box (an accessory) together with the Shield Case when requesting for the replacement or repair. Transporting the Game Board in an undesignated status for replacement/repair is unacceptable.

### 18 - 1 TAKING OUT THE BOARD

- ① Turn power off.
- ② Take out the 2 truss screws, unlock and remove the Back Door Lower.
- ③ Disconnect all of the Connectors connected to ASSY MAIN BOARD DX.
- ④ Remove the 2 Wing Bolts and take out ASSY MAIN BD DX with the Shield Case as is mounted.

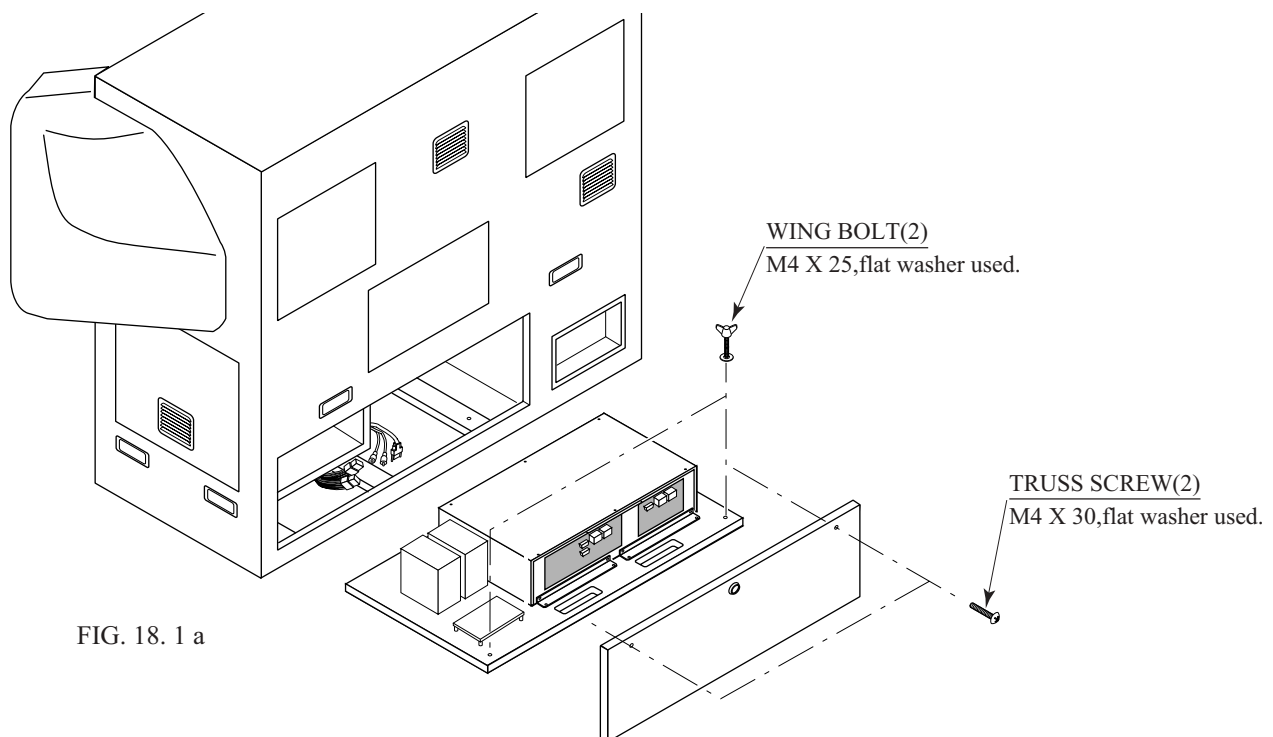

FIG. 18. 1 a

CONNECTING THE VIDEO SIGNAL LINE AND AUDIO SIGNAL LINE

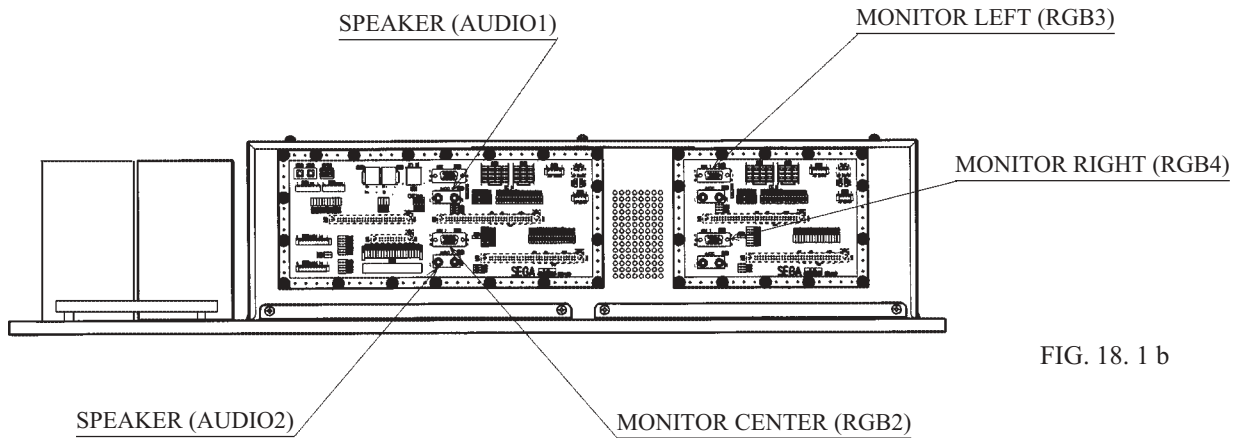

FIG. 18. 1 b

18 - 2 COMPOSITION OF GAME BOARD

- GAME BD FRI DX USA (833-13841-01) : USA
- GAME BD FRI DX EXP (833-13841-02) : OTHERS
- GAME BD FRI DX KOR (833-13841-03) : KOREA
- GAME BD FRI DX AUS (833-13841-04) : AUSTRALIA



PHOTO 18. 2

DIP SW SETTING

In the product, set all of the DIP SWes to OFF.

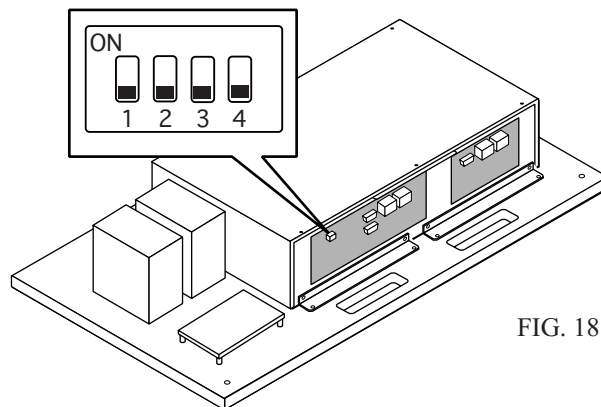
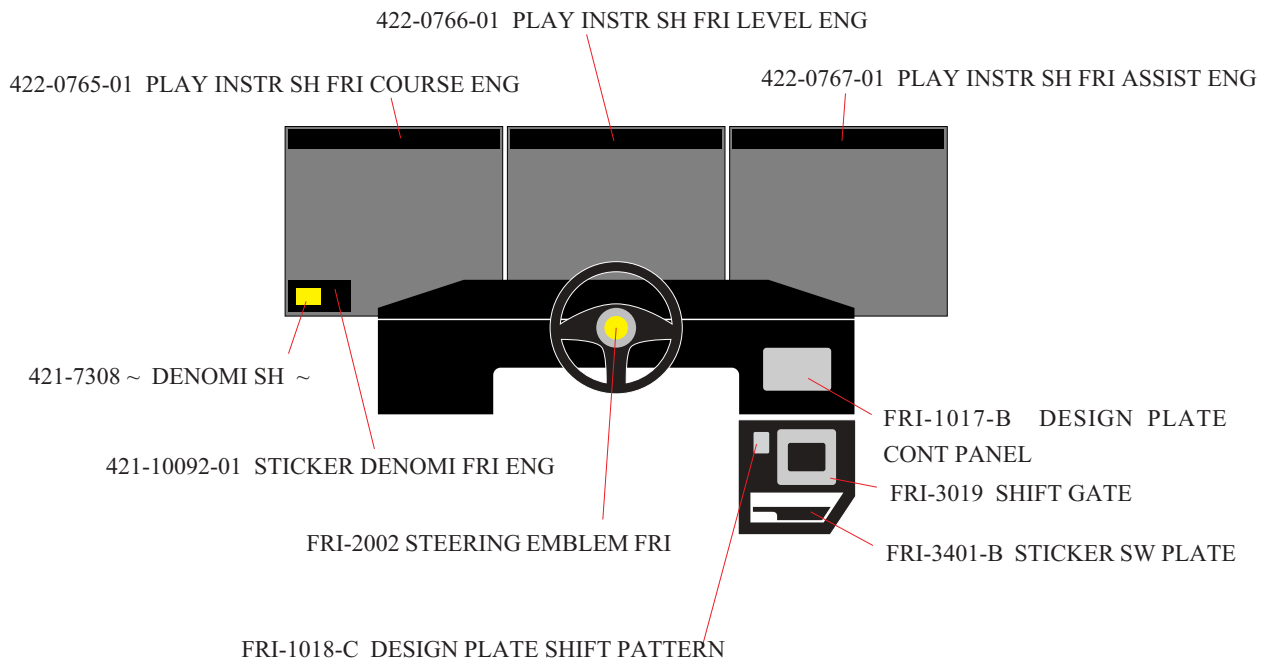

FIG. 18. 2

# 19. DESIGN RELATED PARTS

For the Warning Display stickers, refer to Section 1.



# 20. PARTS LIST

## ① TOP ASSY FRI DX

(D-1/3)

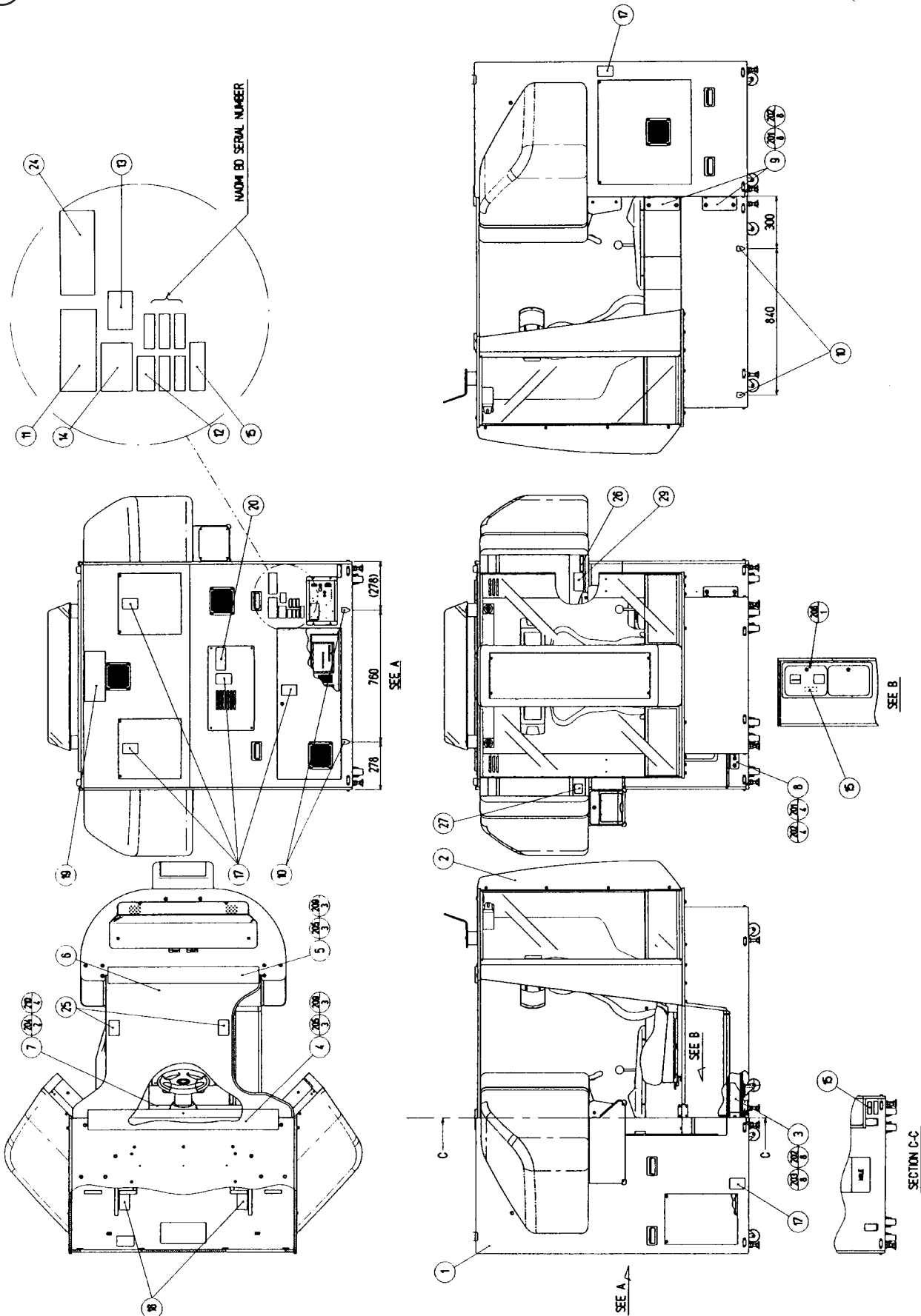



ITEM NO.	PART NO.	DESCRIPTION	NOTE
1	FRI-1000	ASSY FRONT CABINET	
2	FRI-3000	ASSY REAR CABINET	
3	APC-0001	JOINT PIPE	
4	FRI-0001	ROOF NUT PLATE F	
5	FRI-0002	ROOF NUT PLATE R	
6	FRI-0003	CENTER ROOF	
7	FRI-0004	JOINT PLATE CENTER	
8	FRI-0005	JOINT BRKT L	
9	FRI-0006	JOINT BRKT R	
10	421-7020	STICKER CAUTION FORK	
16	421-8479-01	STICKER INSTR SUNLIGHT ENG	
17	440-WS0002XEG	STICKER W POWER OFF ENG	
18	440-DS0013XEG	STICKER D MONITOR ENG	
19	440-WS0170-JP	STICKER W FALL DOWN	
20	440-CS0181-EG	STICKER C DOOR HINGE ENG	
22	SGM-4048	POLY COVER 1250 X 1800 X 2100	
23	FRI-0007	SHIPPING BRKT REAR	
25	440-CS0179-EG	STICKER C DO NOT GET ON ENG	
28	SGM-4507	POLY COVER 1700 X 1700 X 1950	
29	440-CS0175-EG	STICKER C CEPILEPSY ENG	
30	421-10097	STICKER FORK POSITION FRI DX	
201	030-000830-SB	HEX BLT W/S BLK M8 X 30	
202	068-852216-0B	FLT WSHR BLK 8.5-22 X 1.6	
203	030-000820-SB	HEX BLT W/S BLK M8 X 20	
204	FAS-300005	HEX BLT CRM W/FS M8 X 30	
205	000-T00630-0B	M SCR TH BLK M6 X 30	
206	000-T00412-0B	M SCR TH BLK M4 X 12	
207	000-P00408-S	M SCR PH W/S M4 X 8	
208	060-F00400	FLT WSHR M4	
209	068-652016-0B	FLT WSHR BLK 6.5-20 X 1.6	
210	000-T00416-0C	M SCR TH CRM M4 X 16	
211	050-000800	HEX NUT M8	
212	008-B00830-0B	TMP PRF SCR BH BLK M8 X 30	
401	220-5576	KEY MASTER FOR 220-5575	
402	SGM-4111	KEY BAG (SGB-1035X)	
403	280-5009-01	CORD CLAMP 21	
404	540-0009-01	WRENCH FOR TAMP SCR M8	
406	600-6729	AC CABLE CONNECT TYPE 15A	AC 110V AREA
	600-6695	AC CABLE CONNECT TYPE USA 15A	AC 120V AREA
	600-6618	AC CABLE CONNECT TYPE FOR EXP	AC 220 ~ 240V AREA
408	220-5484	VOL CONT B-5K OHM	
	220-5373	VOL CONT B-5K OHM	
409	514-5086-6300	FUSE S.B 6300MA 250V HBC CE	
410	509-5636	SW MICRO TYPE SS-5GL2T	
411	509-5387	SW MICRO TYPE	
413	420-6507-01	OWNERS MNL FRI DX ENG	
414	420-6508-01	SERVICE MANUAL FRI DX ENG	

① TOP ASSY FRI DX

( D-2/3 )

ITEM NO.	PART NO.	DESCRIPTION	NOTE
/	105-5356	SHIPPING BRKT	
/	421-8740	CAUTION INSTR COP U/R	
/	280-6609	REPEAT TIE RF140	
/	421-6690-06	STICKER 110V	AC 110V AREA
/	421-6690-03	STICKER 220V	AC 220V AREA
/	421-6690-05	STICKER 240V	AC 240V AREA
/	421-6690-01	STICKER 120V	AC 120V AREA
/	421-7308 ~	DENOMI SH 1GAME ~	
	421-6119-91	STICKER FCC	3
	421-6120-91	STICKER SEGA USA	1 2 USA

② ASSY FRONT CABINET (FRI-1000)

(D-1/3)

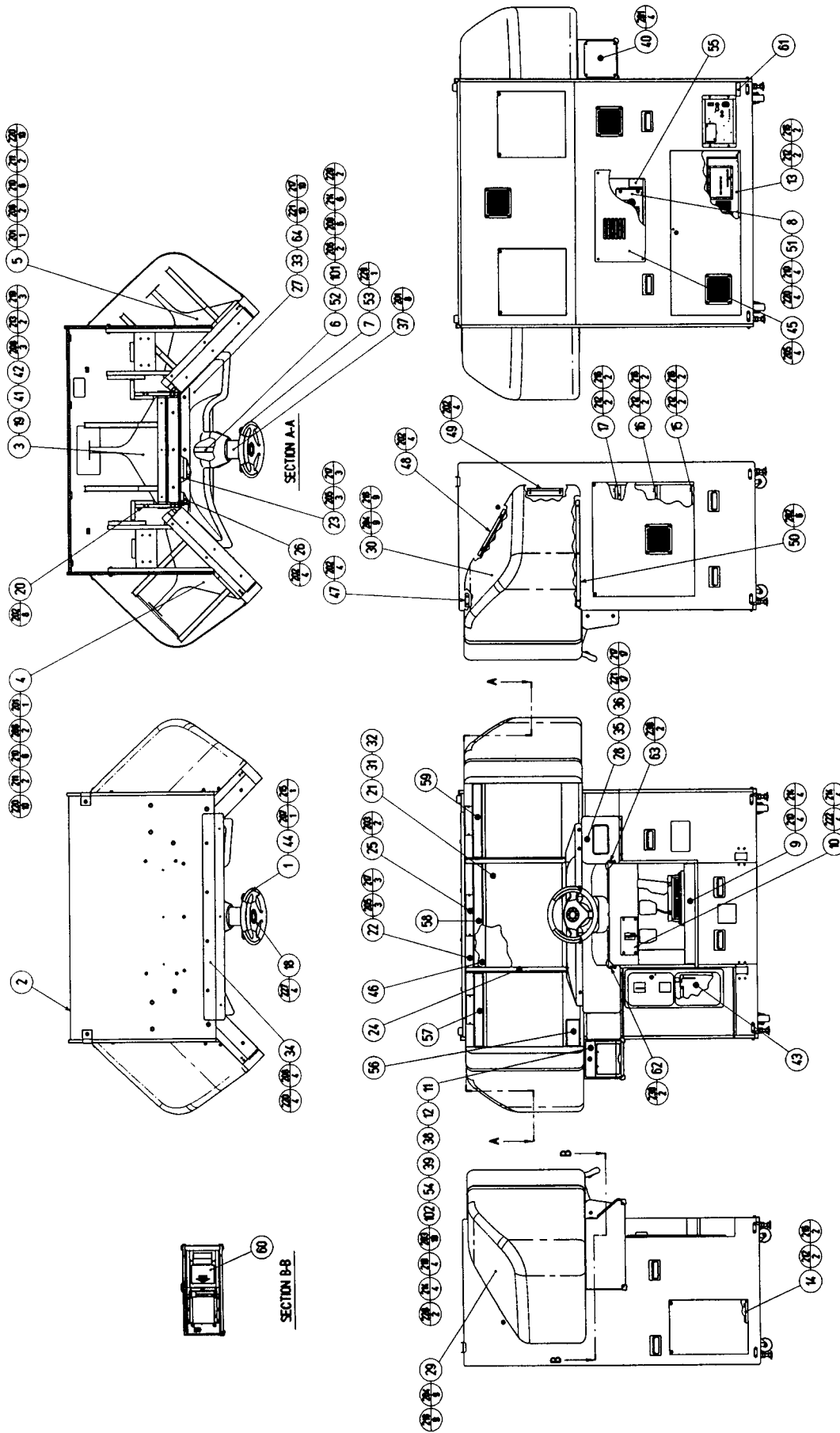

NOTE) M8 BOLT FASTENING TORQUE TO BE: 178kgf\*cm

② ASSY FRONT CABINET (FRI-1000)

( D-2/3 )

ITEM NO.	PART NO.	DESCRIPTION	NOTE
1	SPG-2001	STEERING WHEEL	
2	FRI-1001	ASSY FRONT SUB-CABI	
3	APC-1100	ASSY MONITOR CENTER	
4	APC-1150	ASSY MONITOR LEFT	
5	APC-1200	ASSY MONITOR RIGHT	
6	FRI-2000	ASSY STEERING MECHA	
7	FRI-2050	ASSY PADDLE SHIFT	
8	FRI-2100	STEERING MOTOR UNIT	
9	FRI-2200	PEDAL UNIT	
10	FRI-2400	CLUTCH UNIT	
13	FRI-4000	ASSY MAIN BD DX	
14	FRI-4100	ASSY PWR SPLY DX	
15	FRI-4200	ASSY I/O BASE DX	
16	FRI-4300	ASSY AUDIO BASE DX	
17	FRI-4400	ASSY SERVO DRV BASE DX	
18	FRI-2002	STEERING EMBLEM FRI	
19	APC-1153X	MONITOR HOLD LOWER	
20	APC-1053X	GLASS HOLDER REAR	
21	APC-1054	GLASS	
22	APC-1055	GLASS HOLDER UPPER CENTER	
23	APC-1056	GLASS HOLDER LOWER CENTER	
24	APC-1057	GLASS SUSH	
25	APC-1058X	MONITOR BD LID	
26	FRI-1015	CONT PNL BRKT UPPER	
27	FRI-1016	CONT PNL UPPER	
28	FRI-1017	CONT PNL LOWER	
29	FRI-1018	MONITOR COVER L	
30	FRI-1019	MONITOR COVER R	
31	601-10562-0170	RUBBER PACKING NO.96 L=170MM	
32	601-10562-0580	RUBBER PACKING NO.96 L=580MM	
33	FRI-1054X	CUSHION SPONGE 550	
34	FRI-1051	ROOF BRKT FRONT	
35	FRI-1052	BOSS PLATE SIDE	
36	FRI-1053	BOSS PLATE CENTER	
37	FRI-2055	BOSS COVER	
38	FRI-2504	PRINTER BLIND LID	
41	280-5112	BUSH FOR TV	
42	280-5113	COLLAR FOR TV	
43	253-5366	CASH BOX	
44	SPG-2039	SPACER RING	
45	APC-1077	AIR VENT PLATE	
46	APC-1083	MONITOR MASK	
47	APC-1014	COVER BRKT A	
48	APC-1015	COVER BRKT B	
49	APC-1016	COVER BRKT C	
50	APC-1017	COVER BRKT D	
51	SRT-3206	KEY 5 X 5 X 17	
52	FRI-2006	KEY 6 X 6 X 16	
53	FRI-2007	KEY 5 X 5 X 10	
55	440-CS0140-JP	STICKER C GEAR	
56	421-10092-01	STISKER DENOMI FRI ENG	
57	422-0765-01	PLAY INSTR SH FRI COURSE ENG	
58	422-0766-01	PLAY INSTR SH FRI LEVEL ENG	
59	422-0767-01	PLAY INSTR SH FRI ASSIST ENG	

② ASSY FRONT CABINET (FRI-1000)

( D-3/3 )

ITEM NO.	PART NO.	DESCRIPTION	NOTE
62	FRI-1055	BLIND PLATE L	
63	FRI-1056	BLIND PLATE R	
64	FRI-1057	CUSHION SPONGE 30	
101	111-1131	COUPLING MJT-40K-BL 16-20	
201	000-T00408-0B	M SCR TH BLK M4 X 8	
202	000-P00416-W	M SCR PH W/FS M4 X 16	
203	000-T00410-0B	M SCR TH M4 X 10 BLK	
204	000-T00410-0C	M SCR TH CRM M4 X 10	
205	000-T00416-0B	M SCR TH BLK M4 X 16	
206	008-B00830-0B	TMP PRF SCR BH BLK M8 X 30	
207	020-000820-0Z	HEX SKT H CAP SCR BLK 0Z M8 X 20	
208	030-000630-SB	HEX BLT BLK W/S M6 X 30	
209	030-000820-SB	HEX BLT W/S BLK M8 X 20	
210	030-000830-SB	HEX BLT W/S BLK M8 X 30	
211	030-000850-SB	HEX BLT W/S BLK M8 X 50	
212	032-000425	WING BLT M4 X 25	
213	050-F00600	FLG NUT M6	
214	060-F00800-0B	FLT WSHR BLK M8	
215	060-S00800-0B	SPR WSHR BLK M8	
216	068-441616	FLT WSHR 4.4-16 X 1.6	
217	068-441616-0B	FLT WSHR BLK 4.4-16 X 1.6	
218	068-441616-0C	FLT WSHR CRM 4.4-16 X 1.6	
219	068-652016-0B	FLT WSHR BLK 6.5-20 X 1.6	
220	068-852216-0B	FLT WSHR BLK 8.5-22 X 1.6	
221	000-T00412-0B	M SCR TH BLK M4 X 12	
222	030-000840-SB	HEX BLT W/S BLK M8 X 40	
225	060-F00400	FLT WSHR M4	
226	000-P00408-W	M SCR PH W/FS M4 X 8	
227	FAS-200013	HEX SKT H CAP SCR CRM M4 X 16	
230	011-T03512	TAP SCR TH 3.5 X 12	
301	600-6972-0600	WIRE HARN EARTH ID5 0600MM	

3 ASSY REAR CABINET (FRI-3000)

(D-1/2)

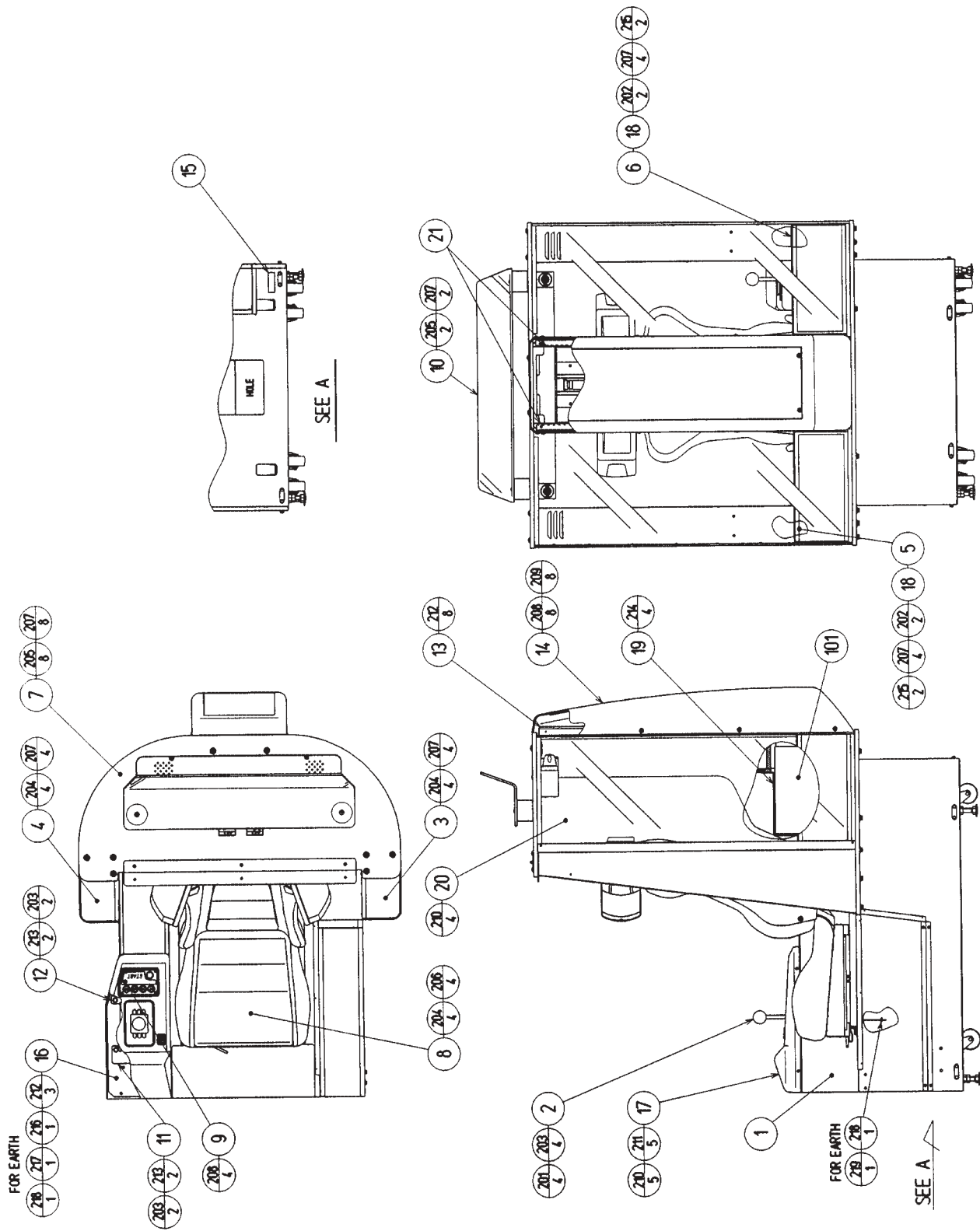

③ ASSY REAR CABINET (FRI-3000)

( D-2/2 )

ITEM NO.	PART NO.	DESCRIPTION	NOTE
1	FRI-3001	ASSY REAR SUB-CABI	
2	FRI-2150	ASSY 6SPEED SHIFTER	
3	FRI-3050	ASSY SIDE TOWER L	
4	FRI-3060	ASSY SIDE TOWER R	
5	FRI-3100	ASSY CORNER LIGHT L	
6	FRI-3150	ASSY CORNER LIGHT R	
7	FRI-3200	ASSY REAR ROOF	
8	FRI-3300	ASSY SEAT	
9	FRI-3400	ASSY EFFECT SW	
10	FRI-0500	ASSY BILLBOARD	
11	FRI-3030	SHIFT BRKT L	
12	FRI-3031	SHIFT BRKT R	
13	FRI-3014	SASH REAR	
14	FRI-3015	REAR FL COVER	
16	FRI-3017	CONSOLE BASE	
17	FRI-3018	CONSOLE COVER	
18	FRI-3156X	CORNER PLATE	
19	FRI-3020	WOOFER HOLDER	
20	FRI-3034	REAR WINDOW	
21	FRI-3055	REAR SASH PACKING	
101	130-5196	WOOFER 4OHM 80W	
201	030-000816-S	HEX BLT W/S M8 X 16	
202	030-000830-S	HEX BLT W/S M8 X 30	
203	060-F00800	FLT WSHR M8	
204	030-000830-SB	HEX BLT W/S BLK M8 X 30	
205	008-B00830-0B	TMP PRF SCR BH BLK M8 X 30	
206	060-F00800-0B	FLT WSHR BLK M8	
207	068-852216-0B	FLT WSHR BLK 8.5-22 X 1.6	
208	000-T00412-0C	M SCR TH CRM M4 X 12	
209	068-441616-0C	FLT WSHR CRM 4.4-16 X 1.6	
210	000-T00412-0B	M SCR TH BLK M4 X 12	
211	068-441616-0B	FLT WSHR BLK 4.4-16 X 1.6	
212	000-P00416-W	M SCR PH W/FS M4 X 16	
213	030-000840-S	HEX BLT W/S M8 X 40	
214	000-T00416-0B	M SCR TH BLK M4 X 16	
215	030-000850-SB	HEX BLT W/S BLK M8 X 50	
216	050-H00400	HEX NUT M4	
217	060-S00400	SPR WSHR M4	
218	060-F00400	FLT WSHR M4	
219	000-P00408-S	M SCR PH W/S M4 X 8	
301	FRI-60071	WIRE HARN SUB WOOFER IN	



④ ASSY BILLBOARD (FRI-0500)

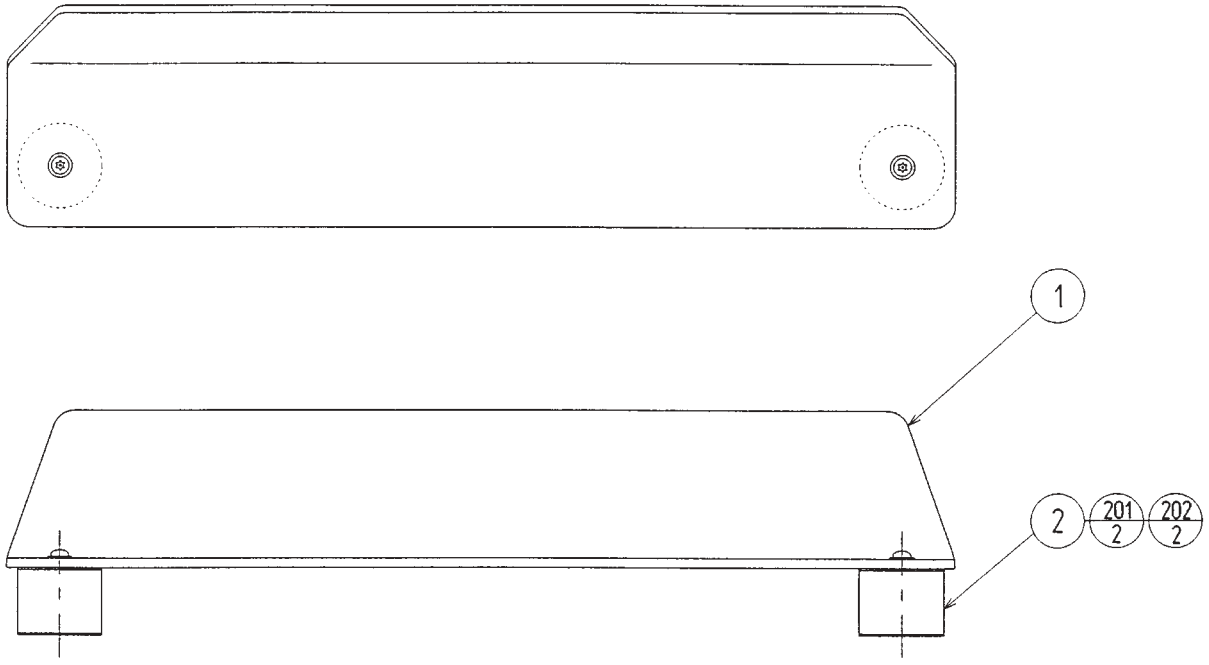

NOTE) M8 TAMPER FASTENING TORQUE TO BE: 30kgf•cm

ITEM NO.	PART NO.	DESCRIPTION	NOTE
1	FRI-0501	BILLBOARD	
2	FRI-0502	BILLBOARD LEG	
201	008-B00830-0B	TMP PRF SCR BH BLK M8 X 30	
202	068-852216-0B	FLT WSHR BLK 8.5-22 X 1.6	

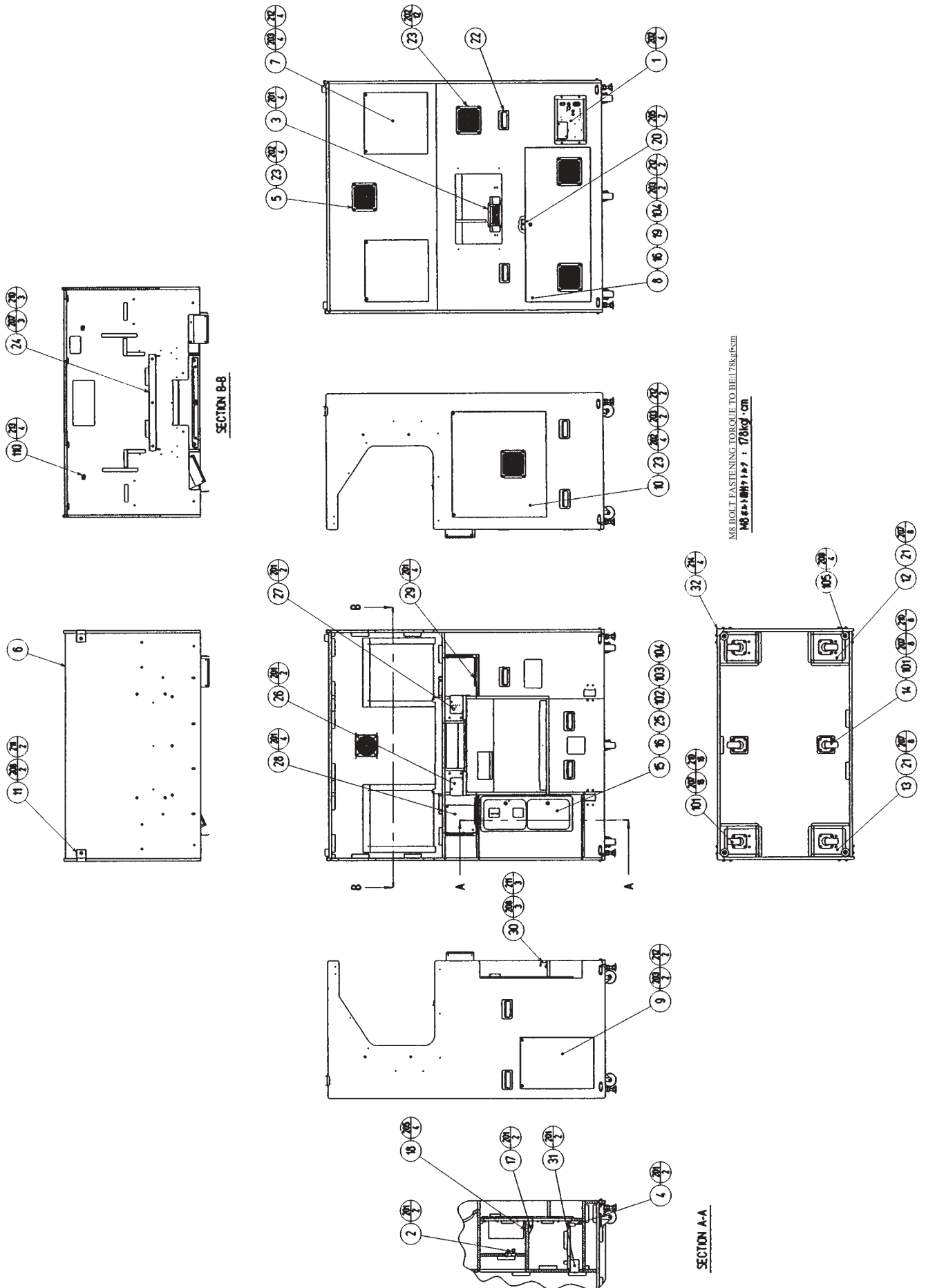

⑤ ASSY FRONT SUB-CABI (FRI-1001)

( D-2/3 )

ITEM NO.	PART NO.	DESCRIPTION	NOTE
1	FRI-1020	AC UNIT	
2	FRI-1030	SW UNIT	
3	APC-1035	FAN MOTOR UNIT	
4	APC-1040	METER UNIT S	OTHERS
	APC-1040-01	METER UNIT	USA
5	STR-1070	FAN UNIT	
6	FRI-1002	WOODEN FRONT CABINET	
7	APC-1003	BACK DOOR UPPER	
8	APC-1004	BACK DOOR LOWER	
9	APC-1005	SIDE DOOR L	
10	APC-1006	SIDE DOOR R	
11	105-5373	SHIPPING BRKT RED	
12	FRI-1007	LEG CASTER BRKT A	
13	FRI-1008	LEG CASTER BRKT B	
14	FRI-1009	CASTER SPACER PLATE	
15	DP-1148X	LKG TNG	
16	DP-1167	TNG LKG	
17	105-5169	LOCK BRACKET W	
18	105-5171	CHUTE PLATE SINGLE	OTHERS
	105-5172	CHUTE PLATE DOUBLE	USA
19	117-0062	PLATE LOCK RETAINER	
20	117-5098	TNG RETAINER PLATE	
21	117-5233	PLATE LEG BRACKET BLACK	
22	253-5396-91	CABINET HANDLE	
23	253-5460-01	AIR VENT BLACK	
24	APC-1009	MONITOR BRKT LOWER	
25	421-7501-02	STICKER 6.3V 0.15A	
26	FRI-1010	CONT PNL BRKT C L	
27	FRI-1011	CONT PNL BRKT C R	
28	FRI-1012	CONT PNL BRKT L	
29	FRI-1013	CONT PNL BRKT R	
30	FRI-1014	FLOOR BRKT	
31	APC-1079	CONN PANEL METER	
32	APC-1090	CORNER GUARD	
101	601-9377	CASTER FAI=75	
102	220-5237-92 ~	ASSY C.C 2DR ~	
	220-5482-91 ~	ASSY C.C 2DR ~	
103	220-5574	CAM LOCK W/KEYS	
104	220-5575	CAM LOCK MASTER W/O KEY	
105	601-5699X	LEG ADJUSTER BOLT M16 X 75	
106	280-5009-01	CORD CLAMP 21	
107	280-0419	HARNESS LUG	
108	310-5029-D20	SUMITUBE F D 20 MM	
109	601-0460	PLASTIC TIE BELT 100 MM	
110	117-5402-06	EARTH TERMINAL PLATE 6P	
111	270-5052-04	L.FILTER D	

⑤ ASSY FRONT SUB-CABI (FRI-1001)

( D-3/3 )

ITEM NO.	PART NO.	DESCRIPTION	NOTE
201	000-P00416-W	M SCR PH W/FS M4 X 16	
202	000-T00420-0B	M SCR TH BLK M4 X 20	
203	000-T00430-0B	M SCR TH BLK M4 X 30	
204	011-F00310	TAP SCR FH 3 X 10	
205	011-T00312	TAP SCR TH 3 X 12	
206	011-T03512	TAP SCR TH 3.5 X 12	
207	030-000630-SB	HEX BLT BLK W/S M6 X 30	
208	030-000830-SB	HEX BLT W/S BLK M8 X 30	
209	050-H01600	HEX NUT M16	
210	060-F00600-0B	FLT WSHR BLK M6	
211	060-F00800-0B	FLT WSHR BLK M8	
212	068-441616-0B	FLT WSHR BLK 4.4-16 X 1.6	
213	011-F03516	TAP SCR FH 3.5 X 16	
214	FAS-110010	TAP SCR FH #1 BLK 3 X 10	
215	000-P00408-S	M SCR PH W/S M4 X 8	
216	050-H00400	HEX NUT M4	
217	060-S00400	SPR WSHR M4	
218	060-F00400	FLT WSHR M4	
301	600-6455-02	WIRE HARN C.C DOOR SINGLE	OTHERS
	600-7134	WIRE HARN COIN CHUTE 2	USA
302	600-6275-0150	ASSY FIBER CABLE 5 0150CM	
303	600-6972-0150	WIRE HARN EARTH ID5 0150MM	
304	600-6972-0400	WIRE HARN EARTH ID5 0400MM	
305	600-6972-1200	WIRE HARN EARTH ID5 1200MM	
306	FRI-6001	ASSY WIRE FRONT CABI AC	
307	FRI-6002	ASSY WIRE FRONT CABI DC	
308	FRI-6004	ASSY WIRE EARTH	
309	600-7195-3000	ASSY PRINTER CABLE 3000 MM	
310	APC-60091	WIRE HARN RGB L	
311	APC-60092	WIRE HARN RGB C	
312	APC-60093	WIRE HARN RGB R	
313	600-7141-100	CABLE JVS TYPE A-B 100CM	
314	FRI-60092	WIRE HARN PRINTER DC	

⑥ AC UNIT (FRI-1020)

( D-1/2 )

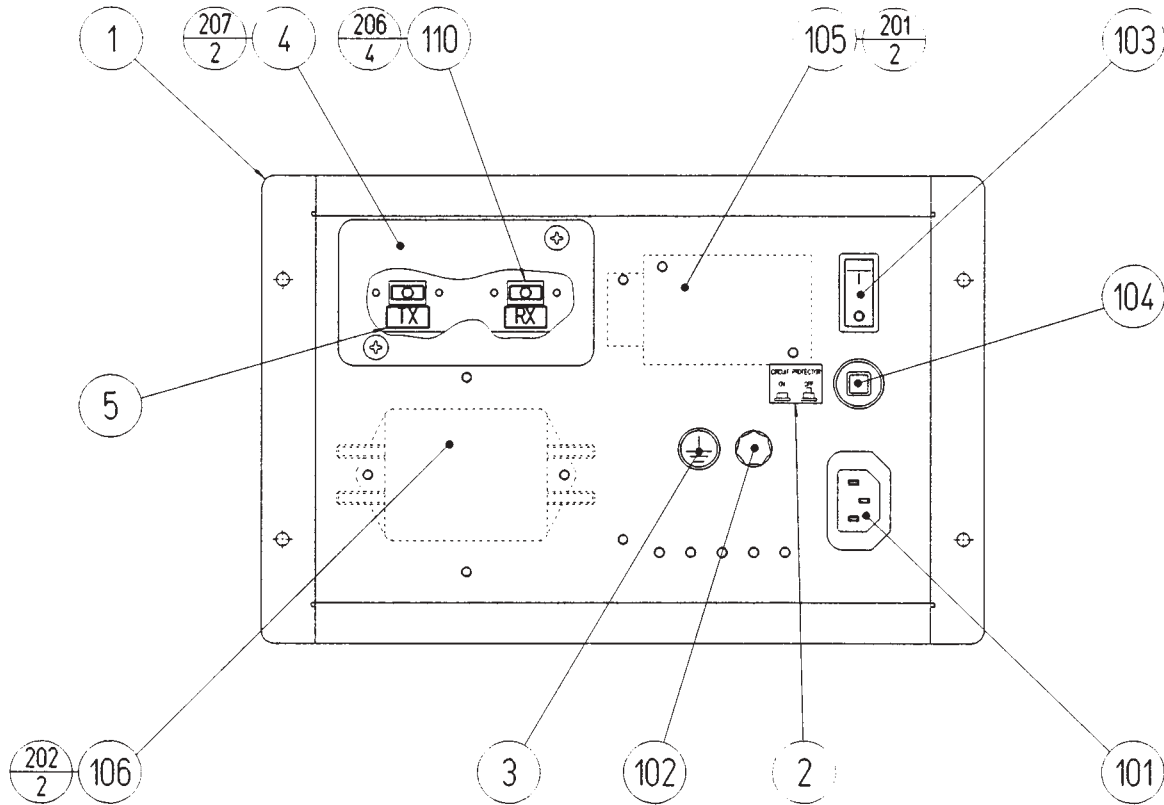

⑥ AC UNIT (FRI-1020)

( D-2/2 )

1	FRI-1021	AC BRACKET	
2	421-7468-01	STICKER C.P W/PIC	
3	421-8202	STICKER EARTH MARK	
4	FRI-1022	CONNECTOR LID	
5	421-7515	STICKER FIBER CABLE TX/RX	
101	214-0202	AC INLET PANEL TYPE	
102	280-0417	TERMINAL BINDING POST BLACK	
103	509-5453-91-V-B	SW ROCKER J8 V-B	
104	512-5046-15000	C.P 15000MA CE UL	AC 110 ~ 120VAREA
	512-5046-8000	C.P 8000MA CE UL	AC 220 ~ 240V AREA
105	450-5126	MAGNET CONTACT S-N10CX	AC 110V AREA
	450-5134	MAGNET CONTACT S-N10CX AC 230V	AC 220 ~ 240VAREA
	450-5135	MAGNET CONTACT S-N10CX AC 120V	AC 120V AREA
106	270-5081	NOISE FILTER 20A	
107	280-5009-01	CORD CLAMP 21	
108	310-5029-G20	SUMITUBE F G 20MM	
109	601-0460	PLASTIC TIE BELT 100 MM	
110	211-5479-01	CONN OPT JOINT	
201	000-P00416-W	M SCR PH W/FS M4 X 16	
202	000-P00408-W	M SCR PH W/FS M4 X 8	
203	050-H00400	HEX NUT M4	
204	060-S00400	SPR WSHR M4	
205	060-F00400	FLT WSHR M4	
206	000-P00312-W	M SCR PH W/FS M3 X 12	
207	000-T00408-0B	M SCR TH BLK M4 X 8	
301	FRI-60001	WIRE HARN AC INLET A	
302	FRI-60002	WIRE HARN AC INLET B	
303	FRI-60003	WIRE HARN EARTH AC INLET	
304	FRI-60004	WIRE HARN CP	
305	FRI-60005	WIRE HARN MAIN SW	
306	FRI-60006	WIRE HARN FILTER IN	
307	FRI-60008	WIRE HARN FILTER OUT	
308	600-6972-0100	WIRE HARN EARTH ID5 0100MM	
309	600-6972-0120	WIRE HARN EARTH ID5 0120MM	
310	600-6972-0700	WIRE HARN EARTH ID5 0700MM	

⑦ SW UNIT (FRI-1030)

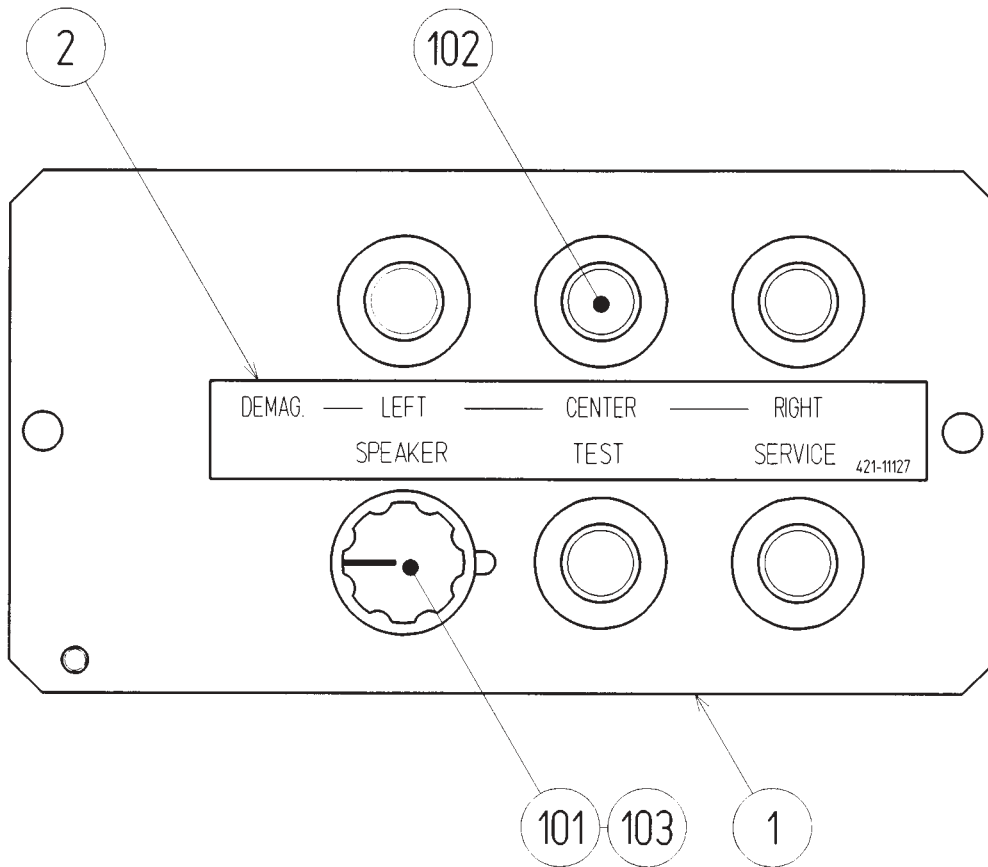

ITEM NO.	PART NO.	DESCRIPTION	NOTE
1	FRI-1031	SW BRACKET	
2	421-11127	STICKER SW UNIT	
101	220-5179	VOL CONT B-5K OHM	
102	509-5028	SW PB 1M	
103	601-0042	KNOB 22 MM	
104	310-5029-D20	SUMITUBE F D 20 MM	
105	601-0460	PLASTIC TIE BELT 100 MM	
301	APC-60087	WIRE HARN DEMAG	
302	600-6609-32	WIRE HARN TEST & SERVICE	
303	FRI-60089	WIRE HARN SOUND VOL	



⑧ FAN MOTOR UNIT (APC-1035)

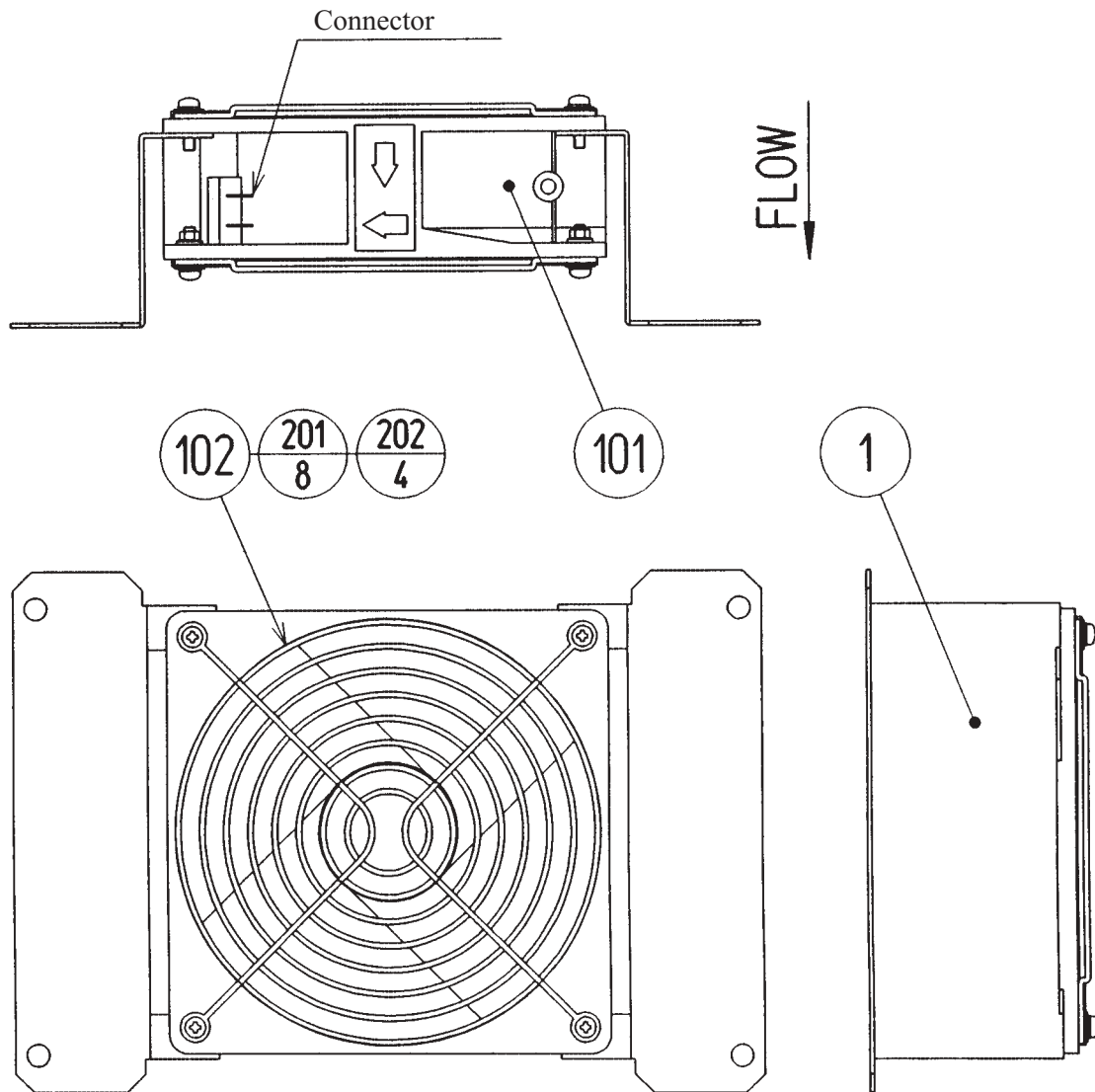

ITEM NO.	PART NO.	DESCRIPTION	NOTE
1	APC-1036	FAN MOTOR BRKT	
101	260-0011-02	AXIAL FLOW FAN AC100V 50-60HZ	
102	601-8543	FAN GUARD	
201	000-P00312-W	M SCR PH W/FS M3 X 12	
202	050-F00300	FLG NUT M3	

⑨ METER UNIT S (APC-1040)

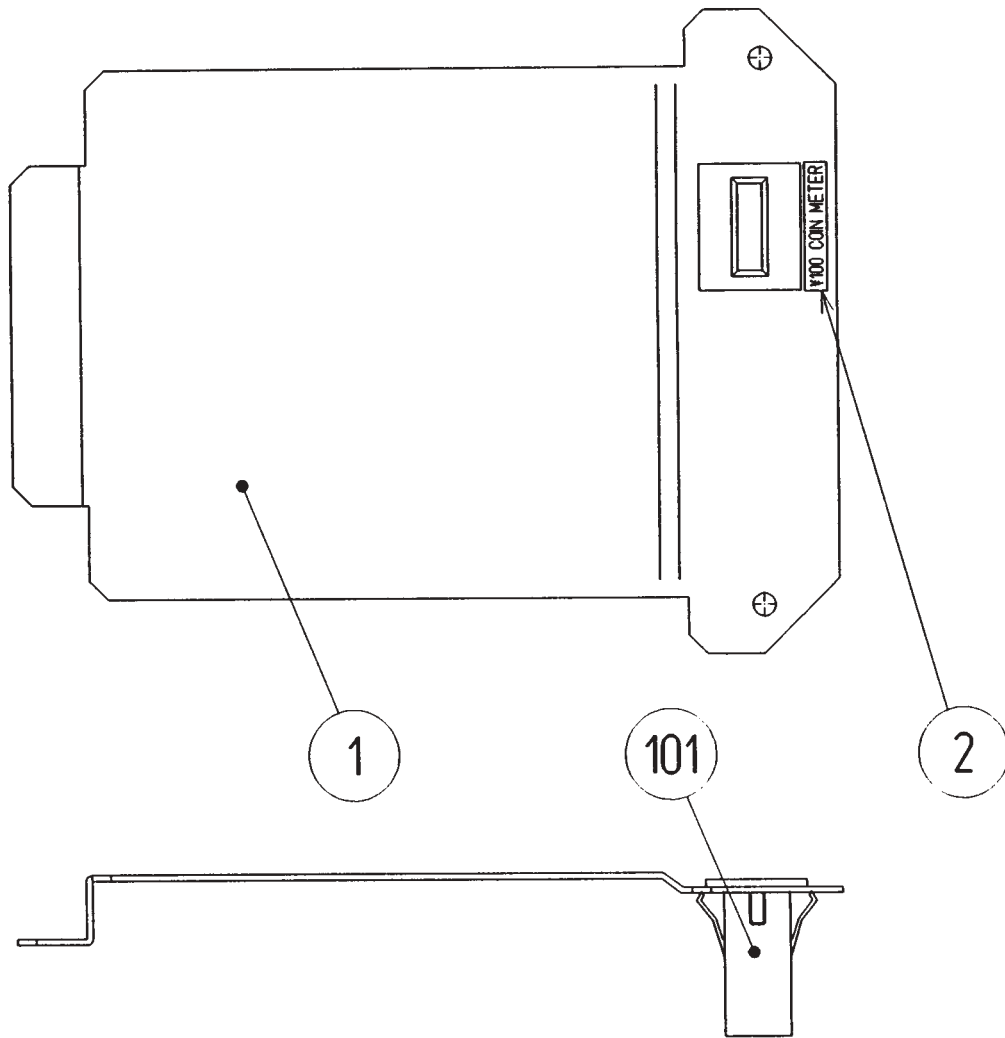

ITEM NO.	PART NO.	DESCRIPTION	NOTE
1	APC-1041	METER BRKT S	
2	421-6591-16	STICKER COIN METER \100	
101	220-5643-01	MAG CNTR DC5V 6P WH MZ-674-D04	

⑨ METER UNIT T (APC-1040-01)

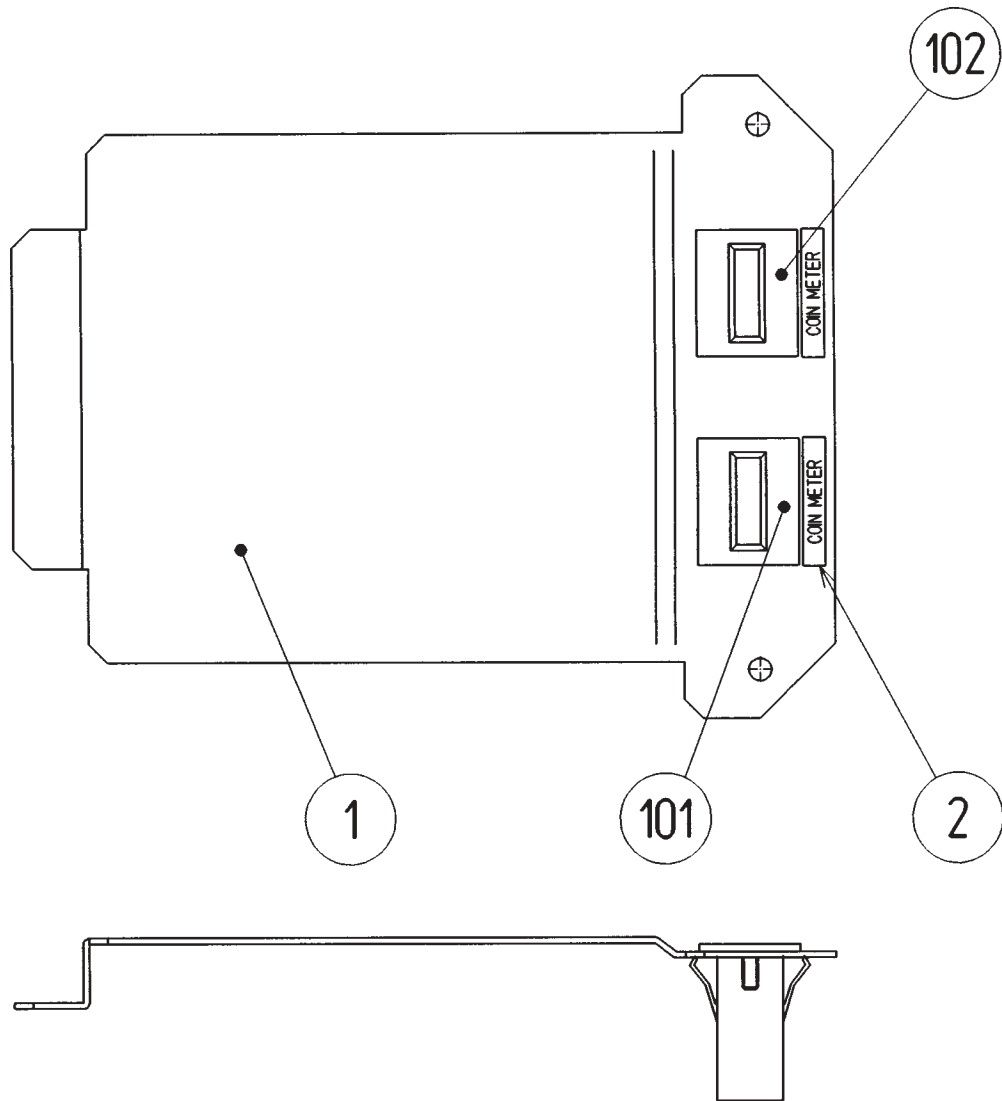

ITEM NO.	PART NO.	DESCRIPTION	NOTE
1	APC-1042	METER BRKT T	
2	421-6591-01	STICKER COIN METER	
101	220-5643-01	MAG CNTR DC5V 6P WH MZ-674-D04	
102	220-5643-02	MAG CNTR DC5V 6P YE MZ-674-D05	

⑩ FAN UNIT (STR-1070)

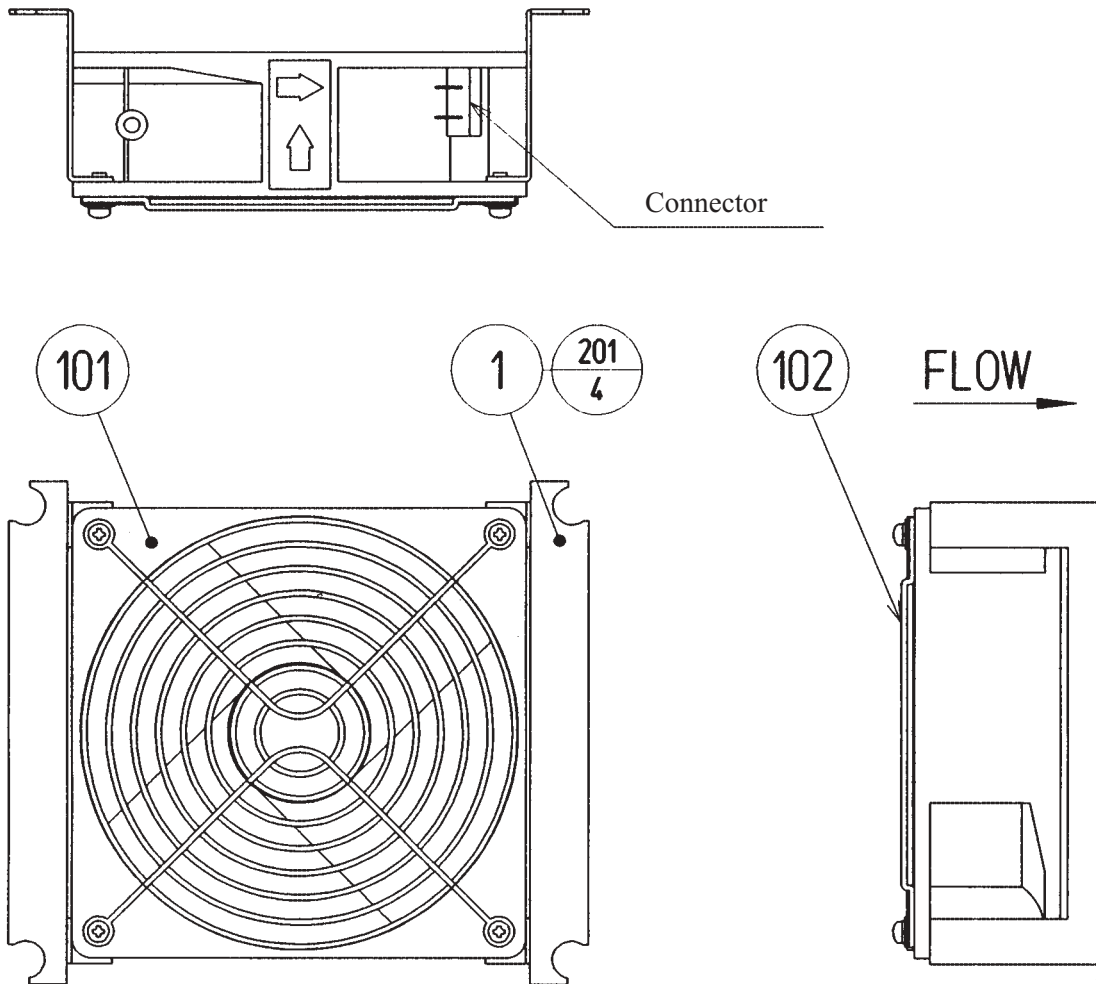

ITEM NO.	PART NO.	DESCRIPTION	NOTE
1	105-5340-01	FAN BRKT LONG	
101	260-0011-02	AXIAL FLOW FAN AC100V 50-60HZ	
102	601-8543	FAN GUARD	
201	000-P00312-W	M SCR PH W/FS M3 X 12	

### ⑪ ASSY WIRE FRONT CABI AC (FRI-6001)

ASSY WIRE FRONT CABI AC is comprised of the following wire harnesses.  
An ASSY DRG. is unavailable.

ITEM NO.	PART NO.	DESCRIPTION	NOTE
101	601-0460	PLASTIC TIE BELT 100 MM	
301	FRI-60045	WIRE HARN EXT AC MONITOR	
302	FRI-60046	WIRE HARN EXT AC REAR	
303	FRI-60047	WIRE HARN EXT AC FRONT	
304	FRI-60061	WIRE HARN EXT SERVO PWR	

### ⑫ ASSY WIRE FRONT CABI DC (FRI-6002)

ASSY WIRE FRONT CABI DC is comprised of the following wire harnesses.  
An ASSY DRG. is unavailable.

ITEM NO.	PART NO.	DESCRIPTION	NOTE
101	601-0460	PLASTIC TIE BELT 100 MM	
301	FRI-60048	WIRE HARN EXT DC	
302	FRI-60049	WIRE HARN EXT SOUND	
303	FRI-60050	WIRE HARN EXT COIN	
304	FRI-60051	WIRE HARN EXT ANALOG	
305	FRI-60052	WIRE HARN EXT SHIFT LOCK A	
306	FRI-60053	WIRE HARN EXT BRAKE LAMP A	
307	FRI-60054	WIRE HARN EXT REAR CTRL A	
308	FRI-60055	WIRE HARN EXT BASS SP	
309	FRI-60056	WIRE HARN EXT SEAT SP A	
311	FRI-60058	WIRE HARN EXT DRV CTRL TX	
312	FRI-60059	WIRE HARN EXT DRV CTRL RX	
313	FRI-60060	WIRE HARN EXT SERVO ENC	
314	FRI-60062X	WIRE HARN EXT PADDLE	

### ⑬ ASSY WIRE EARTH (FRI-6004)

ASSY WIRE EARTH is comprised of the following wire harnesses.  
An ASSY DRG. is unavailable.

ITEM NO.	PART NO.	DESCRIPTION	NOTE
101	601-0460	PLASTIC TIE BELT 100 MM	
301	600-6972-0700	WIRE HARN EARTH ID5 0700MM	
302	600-6972-1800	WIRE HARN EARTH ID5 1800MM	
303	600-6972-2200	WIRE HARN EARTH ID5 2200MM	
304	600-6972-2250	WIRE HARN EARTH ID5 2250MM	
305	600-6972-3000	WIRE HARN EARTH ID5 3000MM	

14 ASSY MONITOR CENTER (APC-1100)

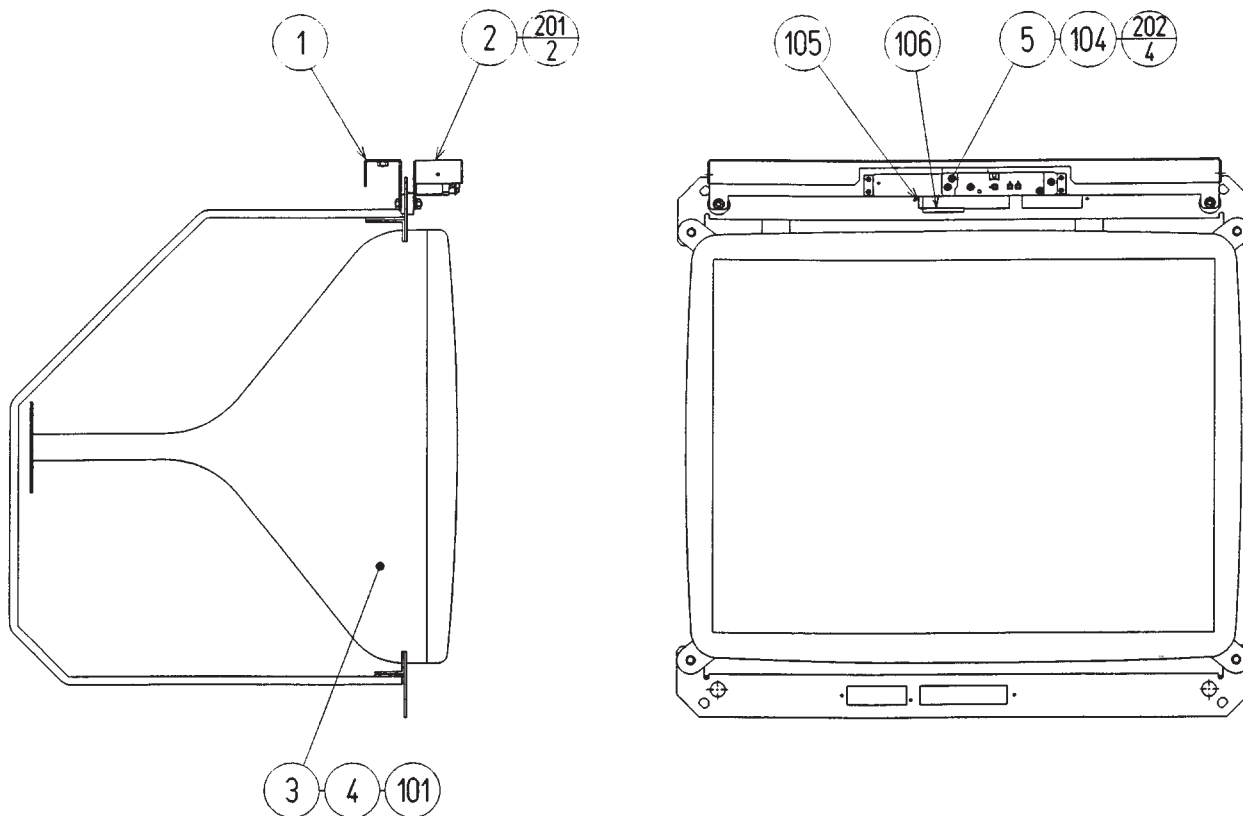

ITEM NO.	PART NO.	DESCRIPTION	NOTE
1	APC-1101	MONITOR BRKT UPPER	
2	APC-1152X	MONITOR HOLD UPPER	
3	280-5112	BUSH FOR TV	
4	280-5113	COLLAR FOR TV	
5	APC-1086	MONITOR BD BASE	
101	200-5710	ASSY CLR DSPL 29AUTO MS-2931-S	
102	280-5275-SR10	CORD CLAMP SR10	
103	280-5009-01	CORD CLAMP 21	
104	280-5185-6	SPACER TUBE L=6	
105	601-6231-D020	EDGING NEW TYPE	
106	601-6231-D045	EDGING NEW TYPE	
201	050-F00600	FLG NUT M6	
202	000-P00312-W	M SCR PH W/FS M3 X 12	
301	600-6972-1600	WIRE HARN EARTH ID5 1600MM	

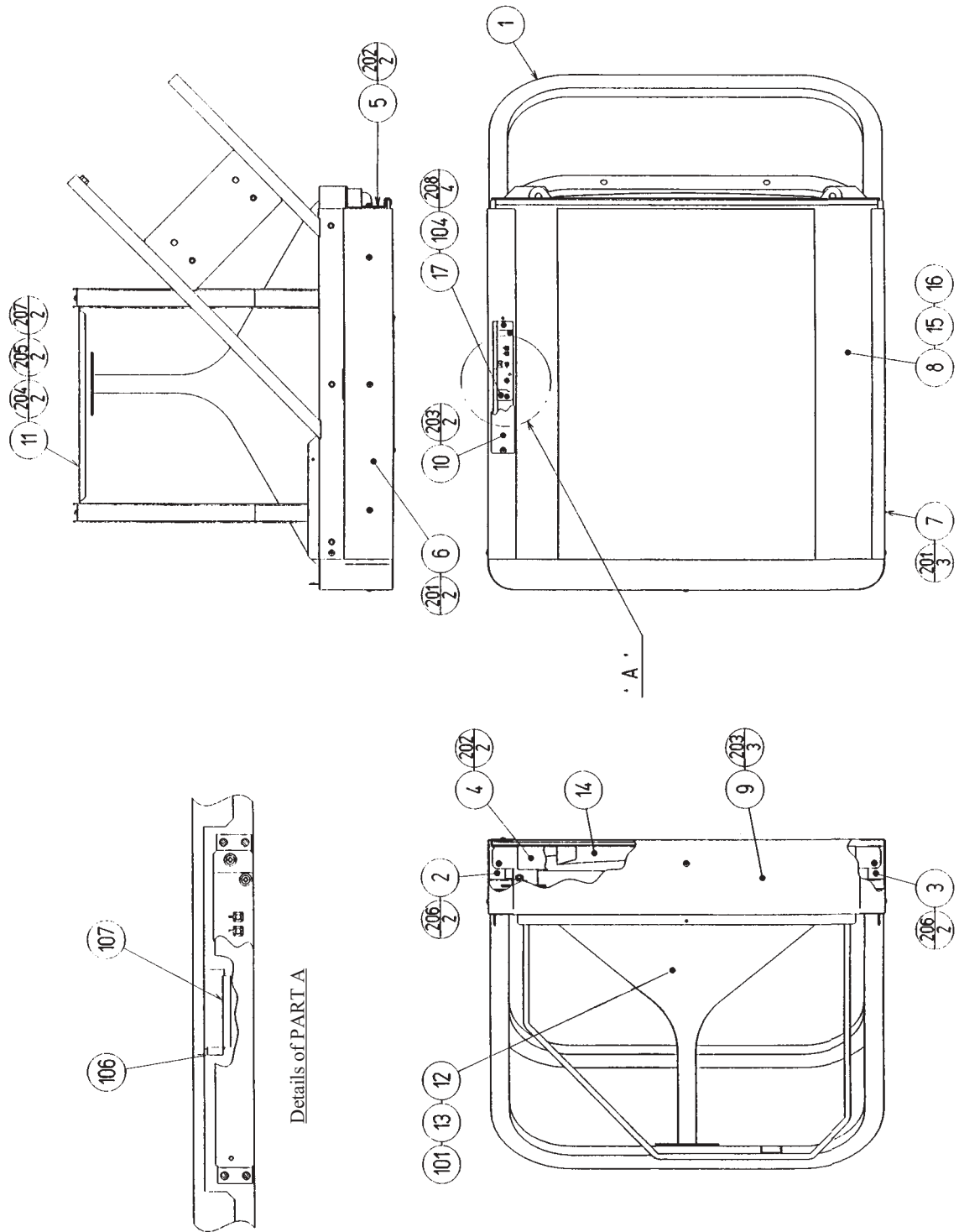



15) ASSY MONITOR LEFT (APC-1150)

( D-2/2 )

ITEM NO.	PART NO.	DESCRIPTION	NOTE
1	APC-1151	MONITOR FRAME	
2	APC-1152X	MONITOR HOLD UPPER	
3	APC-1153X	MONITOR HOLD LOWER	
4	APC-1154X	SIDE COVER BRKT	
5	APC-1155X	SIDE BRKT	
6	APC-1156X	GLASS HOLDER UPPER SIDE	
7	APC-1157X	GLASS HOLDER LOWER SIDE	
8	APC-1054	GLASS	
9	APC-1159X	MONITOR SIDE COVER	
10	APC-1058X	MONITOR BD LID	
11	APC-1160	WIRE BRKT	
12	280-5112	BUSH FOR TV	
13	280-5113	COLLAR FOR TV	
14	APC-1083	MONITOR MASK	
15	601-10562-0170	RUBBER PACKING NO.96 L=170MM	
16	601-10562-0580	RUBBER PACKING NO.96 L=580MM	
17	APC-1086	MONITOR BD BASE	
101	200-5710	ASSY CLR DSPL 29AUTO MS-2931-S	
102	280-5275-SR10	CORD CLAMP SR10	
103	280-5009-01	CORD CLAMP 21	
104	280-5185-6	SPACER TUBE L=6	
105	280-5292	CORD CLAMP 18 PUSH TYPE	
106	601-6231-D010	EDGING NEW TYPE L=10	
107	601-6231-D045	EDGING NEW TYPE	
201	000-F00410-0B	M SCR FH BLK M4 X 10	
202	000-P00408-W	M SCR PH W/FS M4 X 8	
203	000-T00408-0B	M SCR TH BLK M4 X 8	
204	000-P00412-W	M SCR PH W/FS M4 X 12	
205	050-F00400	FLG NUT M4	
206	050-F00600	FLG NUT M6	
207	068-441616	FLT WSHR 4.4-16 X 1.6	
208	000-P00312-W	M SCR PH W/FS M3 X 12	
301	600-6972-1600	WIRE HARN EARTH ID5 1600MM	

16 ASSY MONITOR RIGHT (APC-1200)

(D-1/2)

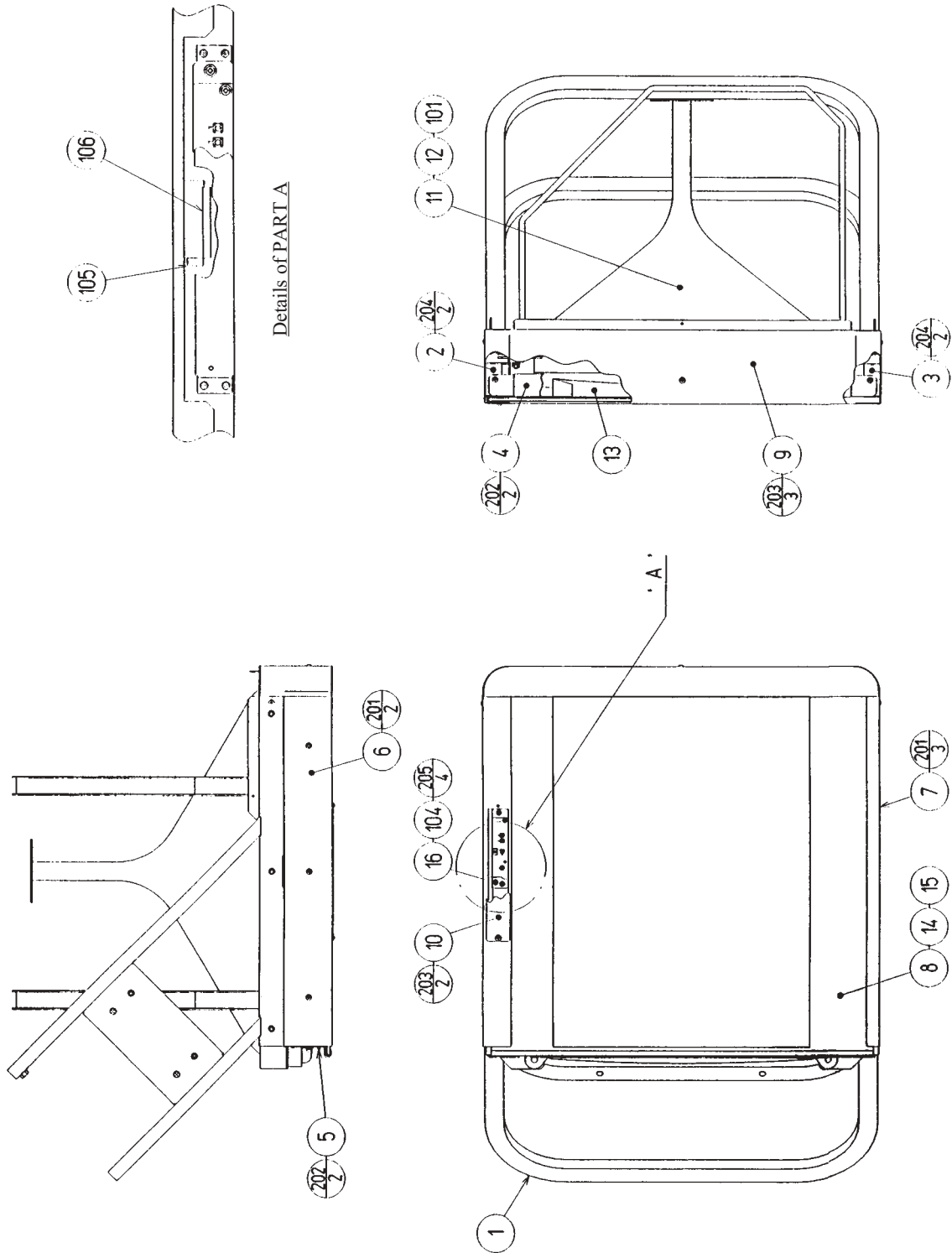

16 ASSY MONITOR RIGHT (APC-1200)

( D-2/2 )

ITEM NO.	PART NO.	DESCRIPTION	NOTE
1	APC-1151	MONITOR FRAME	
2	APC-1152X	MONITOR HOLD UPPER	
3	APC-1153X	MONITOR HOLD LOWER	
4	APC-1154X	SIDE COVER BRKT	
5	APC-1155X	SIDE BRKT	
6	APC-1156X	GLASS HOLDER UPPER SIDE	
7	APC-1157X	GLASS HOLDER LOWER SIDE	
8	APC-1054	GLASS	
9	APC-1159X	MONITOR SIDE COVER	
10	APC-1058X	MONITOR BD LID	
11	280-5112	BUSH FOR TV	
12	280-5113	COLLAR FOR TV	
13	APC-1083	MONITOR MASK	
14	601-10562-0170	RUBBER PACKING NO.96 L=170MM	
15	601-10562-0580	RUBBER PACKING NO.96 L=580MM	
16	APC-1086	MONITOR BD BASE	
101	200-5710	ASSY CLR DSPL 29AUTO MS-2931-S	
102	280-5275-SR10	CORD CLAMP SR10	
103	280-5009-01	CORD CLAMP 21	
104	280-5185-6	SPACER TUBE L=6	
105	601-6231-D010	EDGING NEW TYPE L=10	
106	601-6231-D045	EDGING NEW TYPE	
201	000-F00410-0B	M SCR FH BLK M4 X 10	
202	000-P00408-W	M SCR PH W/FS M4 X 8	
203	000-T00408-0B	M SCR TH BLK M4 X 8	
204	050-F00600	FLG NUT M6	
205	000-P00312-W	M SCR PH W/FS M3 X 12	
301	600-6972-1600	WIRE HARN EARTH ID5 1600MM	

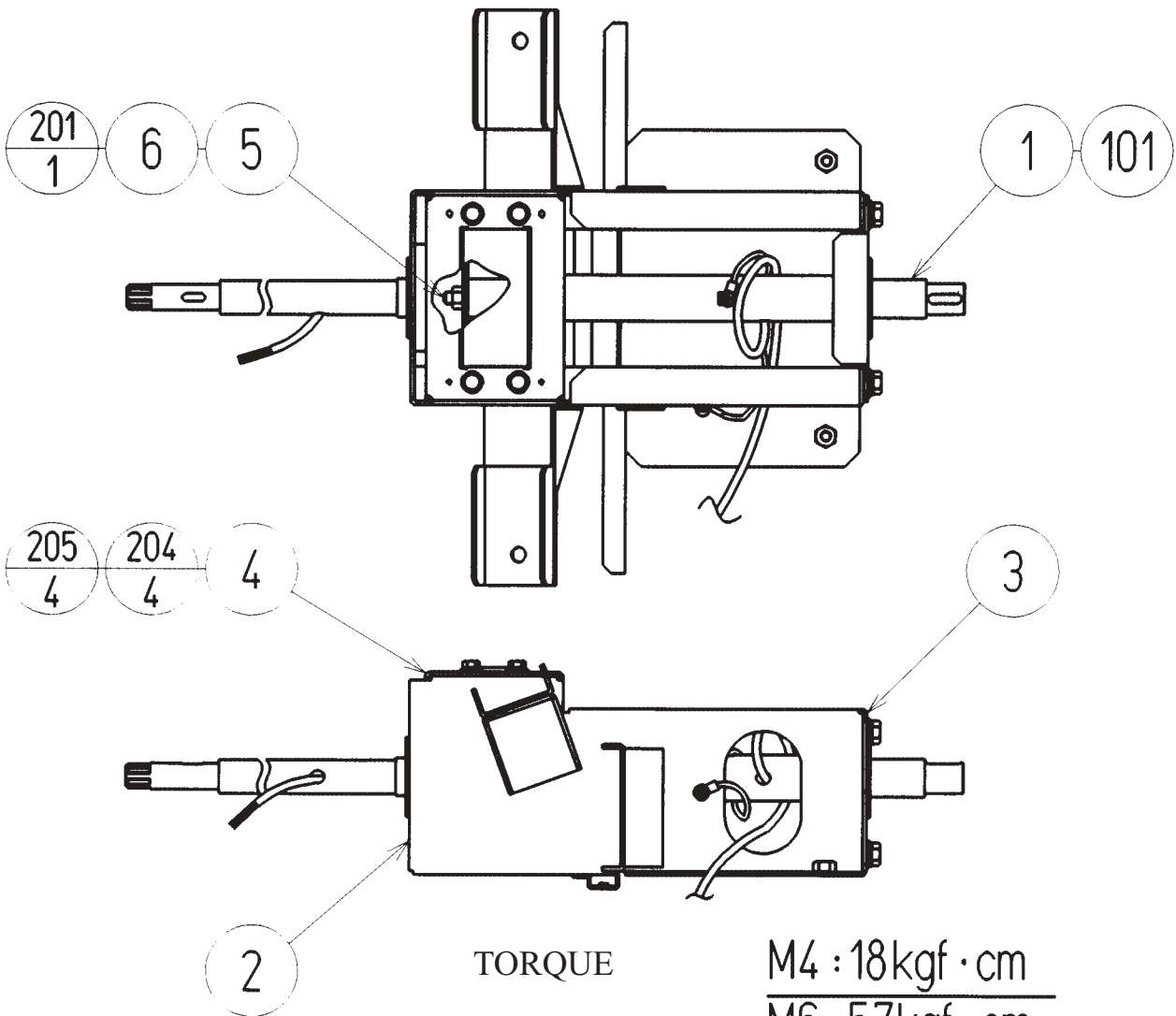

TORQUE

M4 : 18kgf · cm

M6 : 57kgf · cm

M8 : 178kgf · cm

17 ASSY STEERING MECHA (FRI-2000)

( D-2/2 )

ITEM NO.	PART NO.	DESCRIPTION	NOTE
1	FRI-2001	STEERING SHAFT	
2	FRI-2003	SHAFT BASE F	
3	FRI-2004	SHAFT BASE R	
4	FRI-2005	STOPPER BASE	
5	SPG-2108	STOPPER BOLT	
6	SPG-2109	STOPPER RUBBER	
101	100-5351	BEARING 25	
102	601-0459	TIE-BELT 150MM	
103	280-5008	CORD CLAMP 15	
104	280-5275-SR10	CORD CLAMP SR10	
105	601-0460	PLASTIC TIE BELT 100MM	
201	050-U00800	U NUT M8	
202	030-000816-S	HEX BLT W/S M8 X 16	
203	060-F00800	FLT WSHR M8	
204	030-000616-S	HEX BLT W/S M6 X 16	
205	060-F00600	FLT WSHR M6	
206	000-P00406-S	M SCR PH W/S M4 X 6	
207	060-F00400	FLT WSHR M4	
208	000-P00408-S	M SCR PH W/S M4 X 8	
301	FRI-60063	WIRE HARN EXT PADDLE TUBE	
302	600-6972-0500	WIRE HARN EARTH ID5 0500MM	
303	600-7204-0500	WIRE HARN BRAID T5.5-5 0500MM	

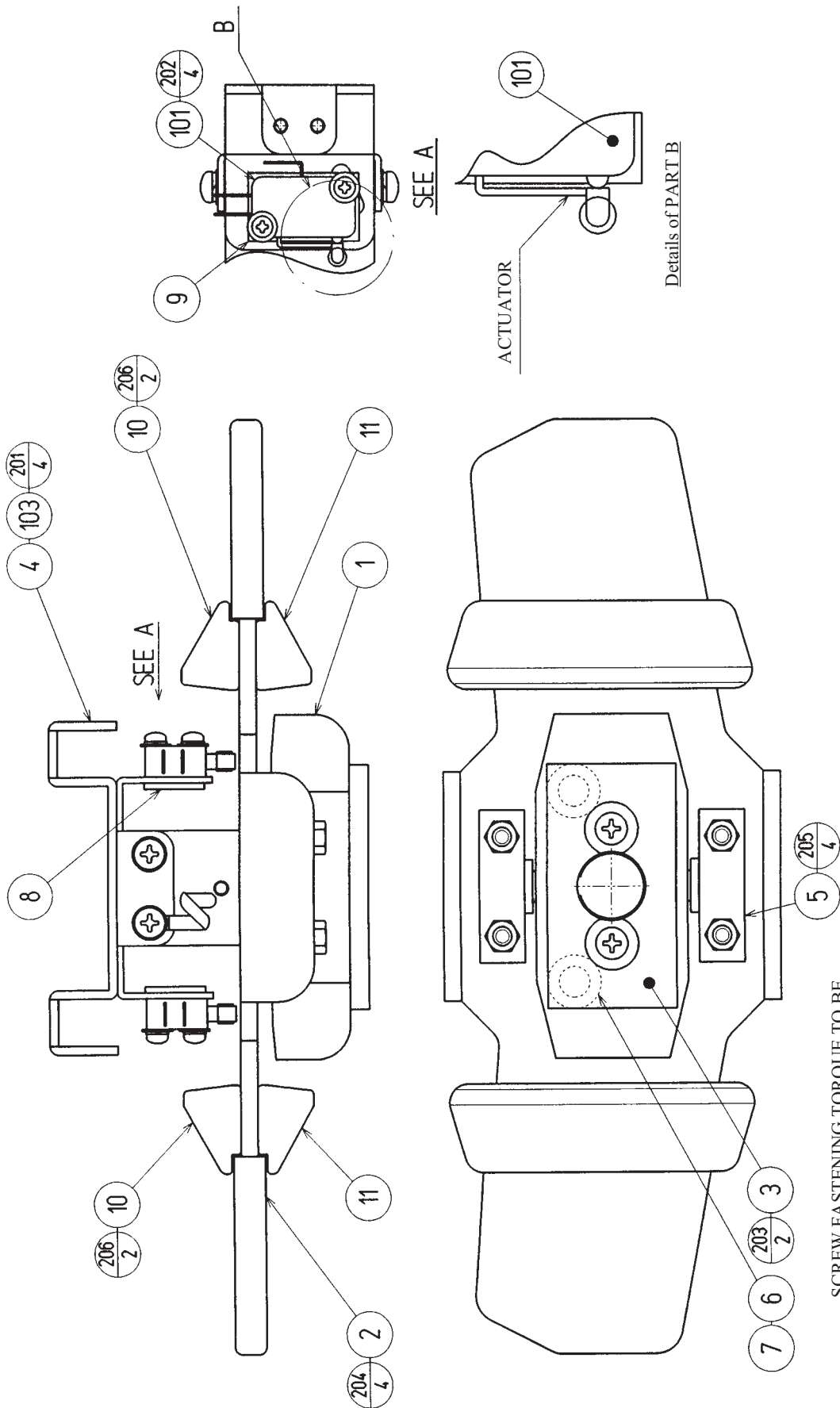

18) ASSY PADDLE SHIFT (FRI-2050)

( D-2/2 )

ITEM NO.	PART NO.	DESCRIPTION	NOTE
1	FRI-2051	BOSS	
2	FRI-2052	SHIFT PLATE	
3	FRI-2053	SPRING LID	
4	FRI-2054	SW BRKT	
5	SLC-1314	PIVOT	
6	SLC-1315X	PLUNGER	
7	SLC-1316	COMP SPRING	
8	117-0141	PLATE LOCK	
9	310-0012	PAPER INSL	
10	FRI-2056X	GUARD BLOCK A	
11	FRI-2057X	GUARD BLOCK B	
101	509-5387	SW MICRO TYPE	
103	280-0419	HARNESS LUG	
104	601-0460	PLASTIC TIE BELT 100MM	
201	000-P00408-S	M SCR PH W/S M4 X 8	
202	000-P00316-W	M SCR PH W/FS M3 X 16	
203	000-F00512	M SCR FH M5 X 12	
204	000-F00525	M SCR FH M5 X 25	
205	050-U00500	U NUT M5	
206	012-P00416	TAP SCR #2 PH 4 X 16	
301	FRI-60086	WIRE HARN PADDLE SHIFT	

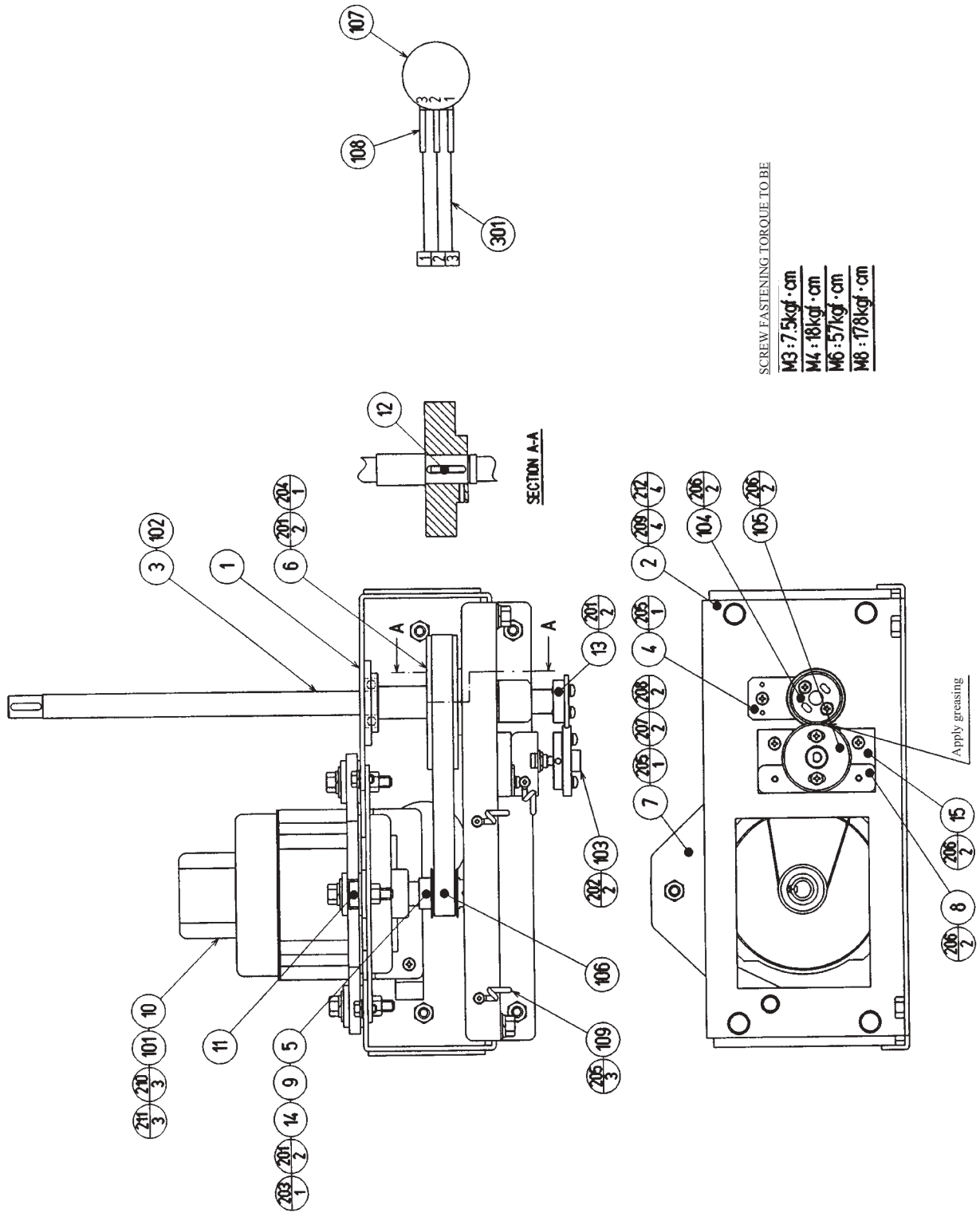



①9 STEERING MOTOR UNIT (FRI-2100)

( D-2/2 )

ITEM NO.	PART NO.	DESCRIPTION	NOTE
1	FRI-2101	MECHA BASE	
2	FRI-2102	BASE LID	
3	FRI-2103	MOTOR SHAFT	
4	FRI-2104	SHAFT LOCK PLATE	
5	SPG-2504	PULLEY 20 S5M	
6	SPG-2505	PULLEY 60 S5M	
7	SPG-2506	MOTOR BRKT	
8	FRI-2105	VR BRKT	
9	SPG-2453	KEY 4 X 4 X 40	
10	ASK-3502	MOTOR SPACER	
11	ASK-3503	MOTOR COLLAR	
12	DYN-1270	STOPPER KEY	
13	SLC-1130	ADJUST RING	
14	SPG-2454	MOTOR COLLAR	
15	FRI-2106	VR BASE	
101	350-5448-01	SERVO MOTOR 500W NEW	
102	100-5112	BEARING 17	
103	601-8966	GEAR HOLDER	
104	601-6172	GEAR 48	
105	601-6959	GEAR 64	
106	601-9173	TIMING BELT	
107	220-5484	VOL CONT B-5K OHM	
	220-5373	VOL CONT B-5K OHM	
108	310-5029-F20	SUMITUBE F F 20MM	
109	280-0419	HARNESS LUG	
110	280-5009-01	CORD CLAMP 21	
201	028-A00408-P	SET SCR HEX SKT CUP P M4 X 8	
202	028-A00308-P	SET SCR HEX SKT CUP P M3 X 8	
203	065-S012S0-Z	STP RING BLK OZ S12	
204	065-S020S0-Z	STP RING BLK OZ S20	
205	000-P00408-W	M SCR PH W/FS M4 X 8	
206	000-P00412-W	M SCR PH W/FS M4 X 12	
207	030-000612-S	HEX BLT W/S M6 X 12	
208	060-F00600	FLT WSHR M6	
209	030-000820-S	HEX BLT W/S M8 X 20	
210	030-000840-S	HEX BLT W/S M8 X 40	
211	068-852216	FLT WSHR 8.5-22 X 1.6	
212	060-F00800	FLT WSHR M8	
301	FRI-60064	WIRE HARN STEERING VOL	

②① PEDAL UNIT (FRI-2200)

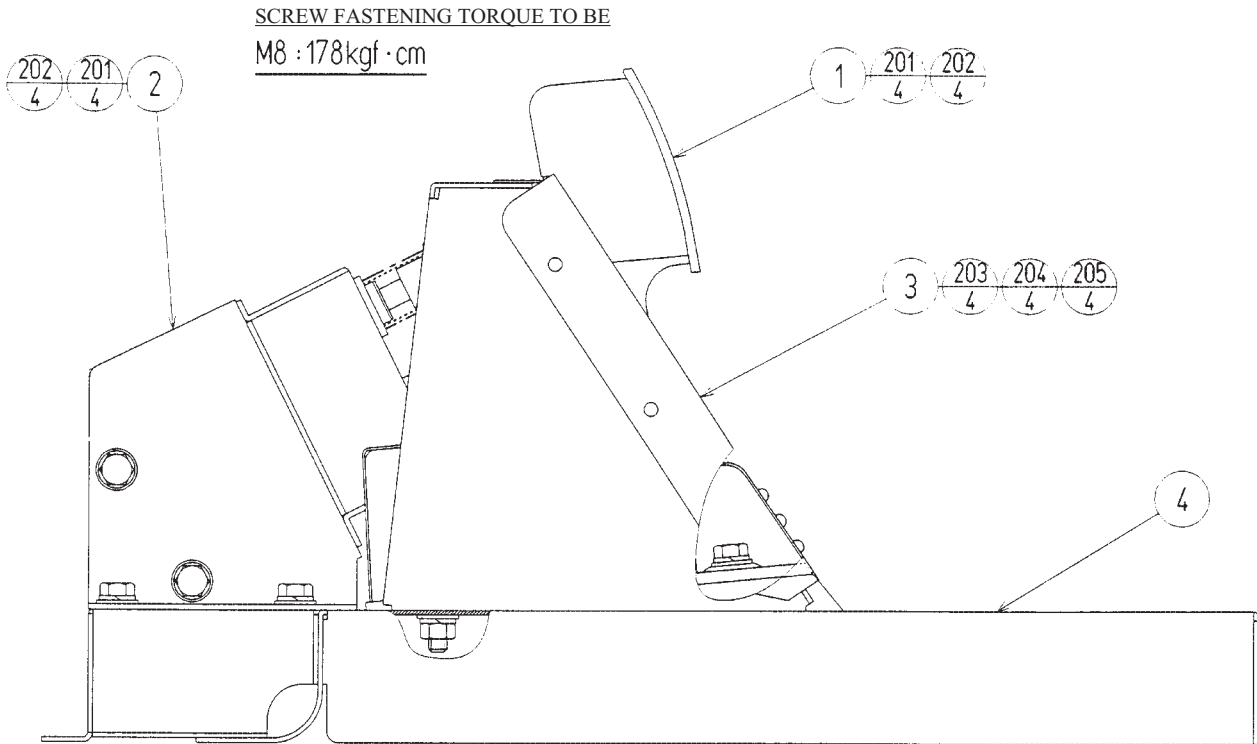

ITEM NO.	PART NO.	DESCRIPTION	NOTE
1	FRI-2250	ASSY ACCEL&BRAKE	
2	FRI-2300	ABSORBER UNIT	
3	FRI-2201	FOOT REST FRI	
4	FRI-2204	PEDAL BASE	
201	030-000825-SB	HEX BLT W/S BLK M8 X 25	
202	060-F00800-0B	FLT WSHR BLK M8	
203	050-H00800	HEX NUT M8	
204	060-S00800	SPR WSHR M8	
205	060-F00800	FLT WSHR M8	

21 ASSY ACCEL&BRAKE (FRI-2250)

(D-1/2)

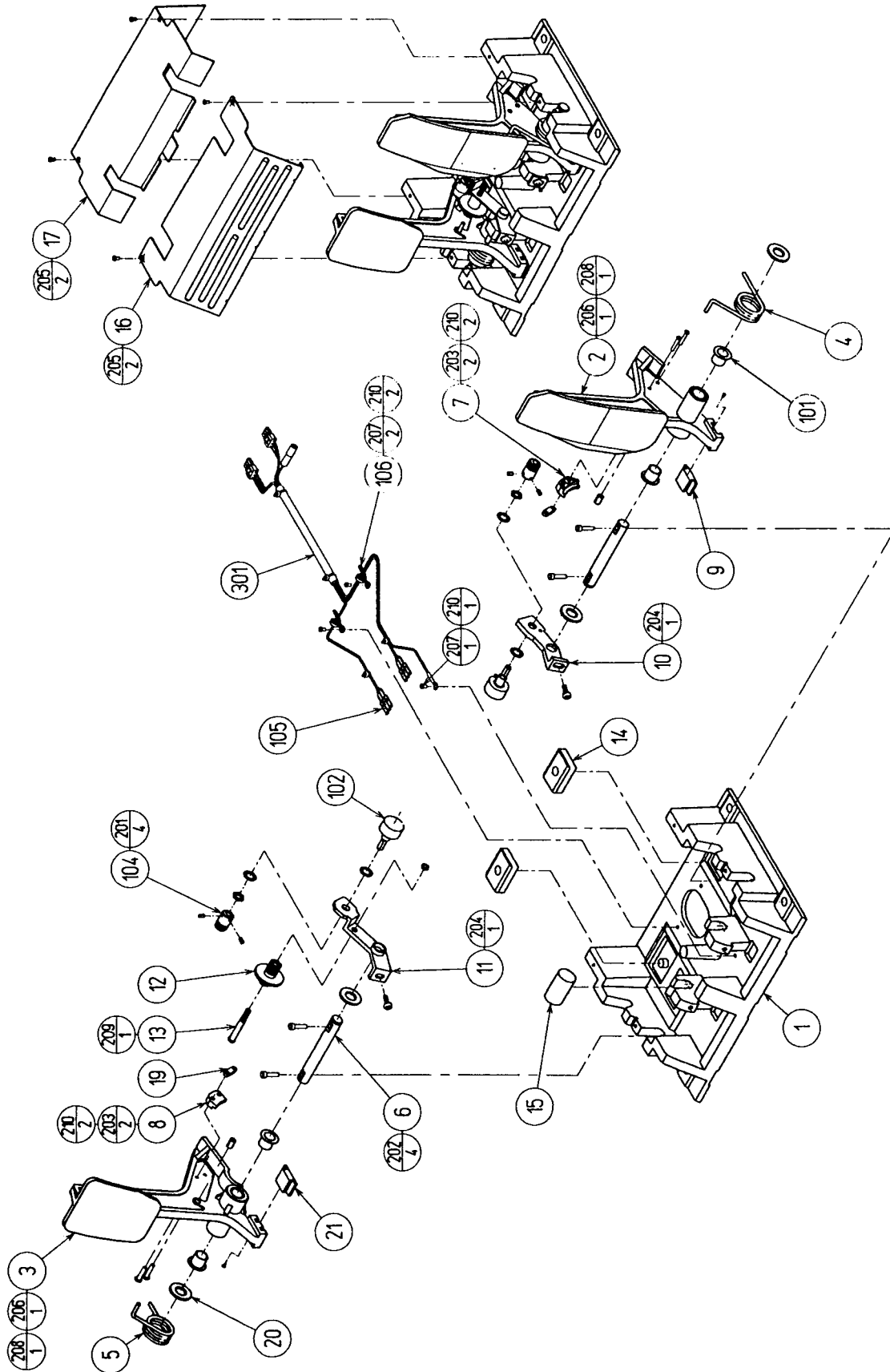

②1 ASSY ACCEL&BRAKE (FRI-2250)

( D-2/2 )

ITEM NO.	PART NO.	DESCRIPTION	NOTE
1	SPG-2201	BASE	
2	FRI-2251	ACCEL PEDAL FRI	
3	FRI-2252	BRAKE PEDAL FRI	
4	FRI-2257	ACCEL SPRING FRI	
5	FRI-2253	BRAKE SPRING FRI	
6	SPG-2206	SHAFT	
7	SPG-2207	ACCEL GEAR	
8	FRI-2254	NEUTRAL STOPPER FRI	
9	SPG-2210	VR PLATE ACCEL	
10	FRI-2255	VR PLATE BRAKE FRI	
11	SPG-2214	STOPPER	
12	SPG-2216	COVER	
13	FRI-2256	VR COVER FRI	
14	SPG-2219	GEAR STAY	
15	SPG-2220	WSHR	
16	FRI-2258	STOPPER PLATE	
17	FRI-2259	GEAR SPACER	
101	100-5263	BEARING 12	
102	220-5484	VOL CONT B-5K OHM	
	220-5373	VOL CONT B-5K OHM	
103	601-7944	GEAR 15	
104	310-5029-F15	SUMITUBE F F 15MM	
105	280-0419	HARNESS LUG	
201	028-A00304-P	SET SCR HEX SKT CUP P M3 X 4	
202	020-000520-0Z	HEX SKT H CAP SCR BLK M5 X 20	
203	000-P00420	M SCR PH M4 X 20	
204	000-P00508-W	M SCR PH W/FS M5 X 8	
205	000-T00408-0C	M SCR TH CRM M4 X 8	
206	FAS-450005	SPR PIN BLK OZ 6 X 10	
207	000-P00405	M SCR PH M4 X 5	
208	FAS-000001	M SCR TH CRM M3 X 6	
209	060-F00400	FLT WSHR M4	
210	000-P00412-W	M SCR PH W/FS M4 X 12	
301	FRI-60088	WIRE HARN ACCEL&BRAKE	

22 ABSORBER UNIT (FRI-2300)

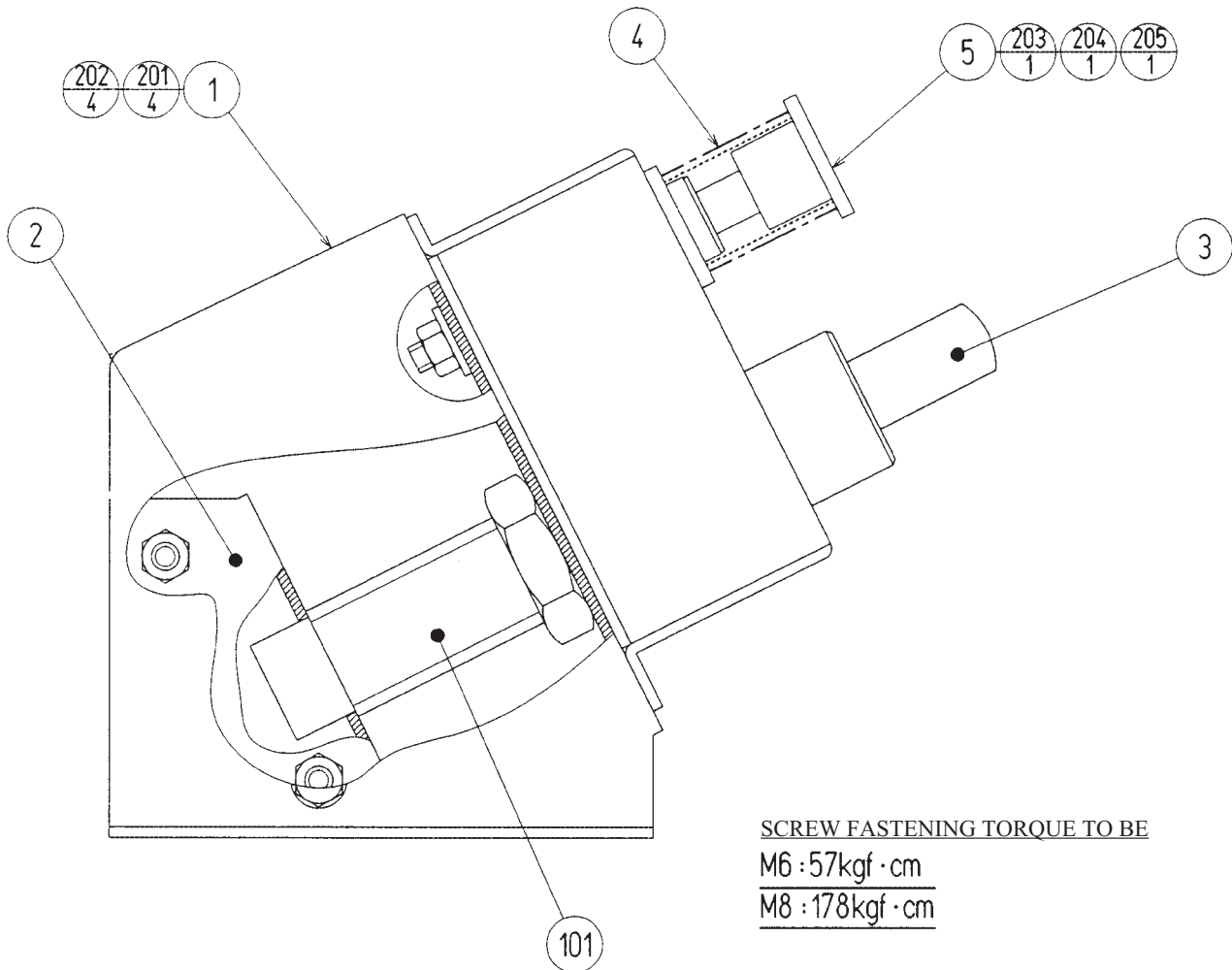

ITEM NO.	PART NO.	DESCRIPTION	NOTE
1	FRI-2301	ABSORBER BRKT	
2	FRI-2302	ABSORBER SUB BRKT	
3	FRI-2303	PLUNGER	
4	FRI-2305	COMP SPRING FRI	
5	FRI-2306	STOPPER SHAFT	
101	601-10662	SHOCK ABSORBER W/O CAP	
201	030-000825-SB	HEX BLT W/S BLK M8 X 25	
202	060-F00800-0B	FLT WSHR BLK M8	
203	060-S00600	SPR WSHR M6	
204	050-U00600	U NUT M6	
205	068-652016	FLT WSHR 6.5-20 X 1.6	

23 CLUTCH UNIT (FRI-2400)

( D-1/2 )

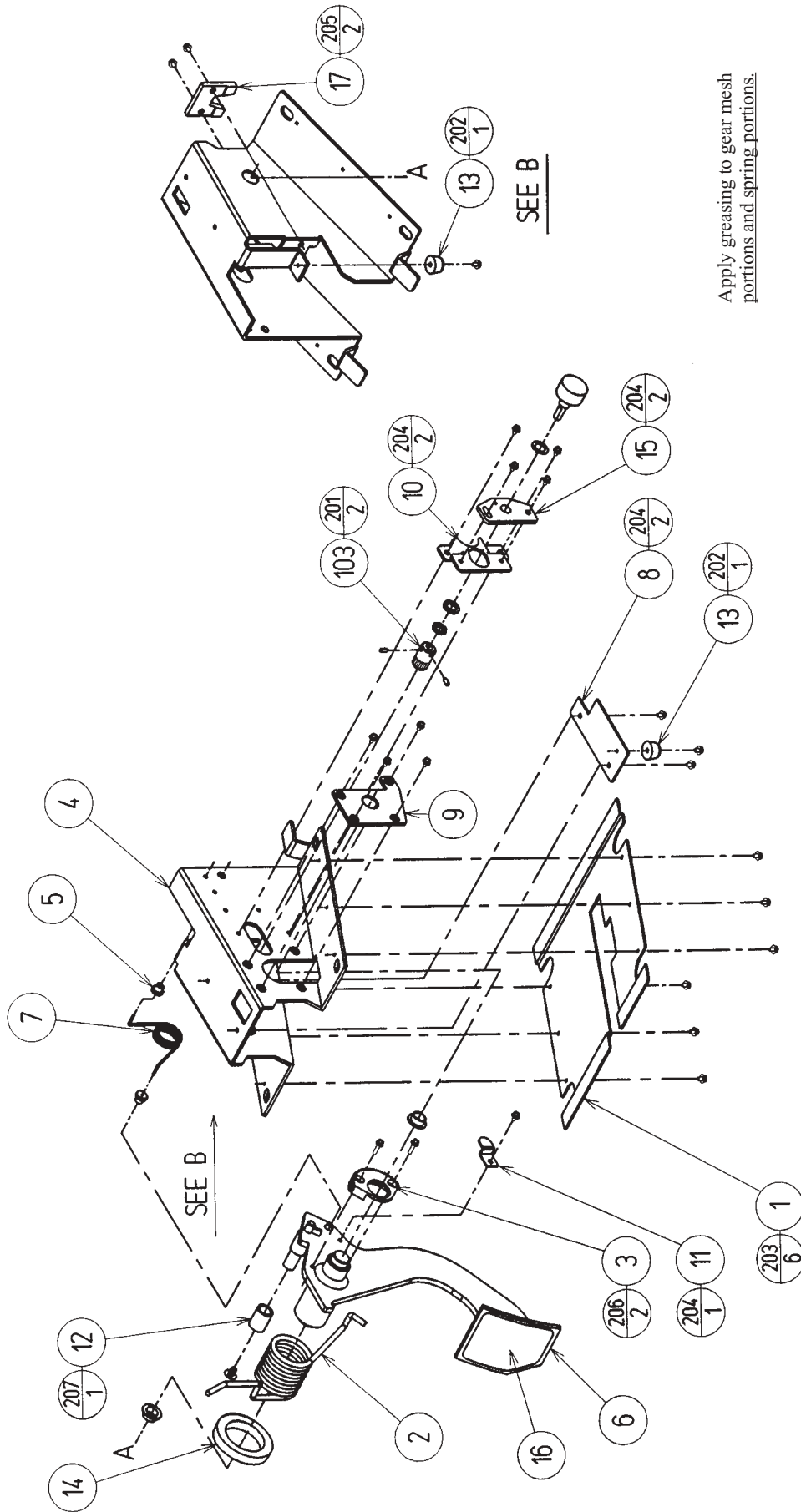

23 CLUTCH UNIT (FRI-2400)

( D-2/2 )

ITEM NO.	PART NO.	DESCRIPTION	NOTE
1	FRI-2401	BOTTOM COVER	
2	FRI-2402	CLUTCH SPRING A	
3	FRI-2403	CLUTCH GEAR	
4	FRI-2404	CLUTCH BASE	
5	FRI-2405	SPRING STOPPER	
6	FRI-2406	CLUTCH PEDAL	
7	FRI-2407	CLUTCH SPRING B	
8	FRI-2408	STOPPER BASE	
9	FRI-2409	BEARING PLATE	
10	FRI-2410	VR BRKT	
11	FRI-2411	SPRING HOLD	
12	FRI-2412	CLUTCH RUBBER B	
13	FRI-2413	CLUTCH RUBBER A	
14	FRI-2414	CLUTCH COLLAR	
15	FRI-2415	INSULATOR	
16	FRI-2416	NON SLIP SHEET	
17	FRI-2417	STOPPER COLLAR	
101	100-5359	BEARING 16	
102	220-5484	VOL CONT B-5K OHM	
	220-5373	VOL CONT B-5K OHM	
103	601-7944	GEAR 15	
104	310-5029-F15	SUMITUBE F F 15MM	
105	280-0419	HARNESS LUG	
106	280-5275-SR10	CORD CLAMP SR10	
201	028-A00304-P	SET SCR HEX SKT CUP P M3 X 4	
202	000-P00308-W	M SCR PH W/FS M3 X 8	
203	000-T00406-0B	M SCR TH BLK M4 X 6	
204	000-P00408-W	M SCR PH W/FS M4 X 8	
205	000-P00410-W	M SCR PH W/FS M4 X 10	
206	000-P00416-W	M SCR PH W/FS M4 X 16	
207	FAS 000062	M SCR TH CRM M6 X 8	
301	FRI-60093	WIRE HARN CLUTCH	

24 ASSY REAR SUB-CABI (FRI-3001)

(D-1/2)

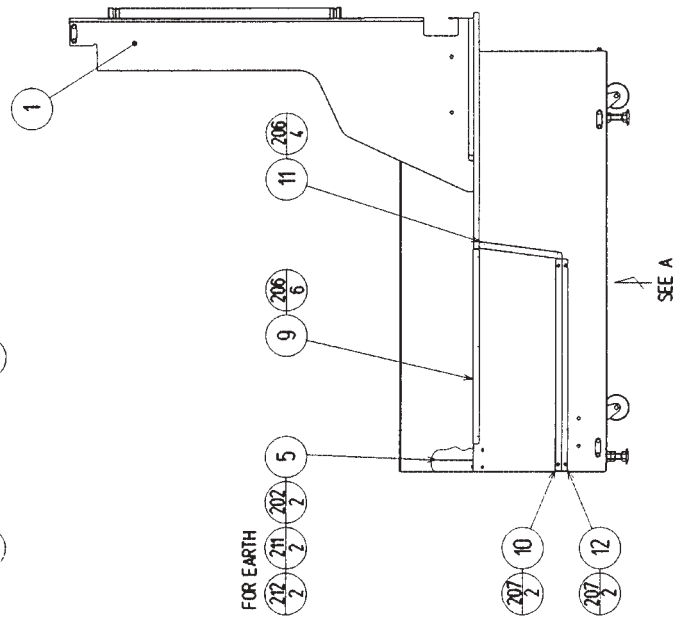
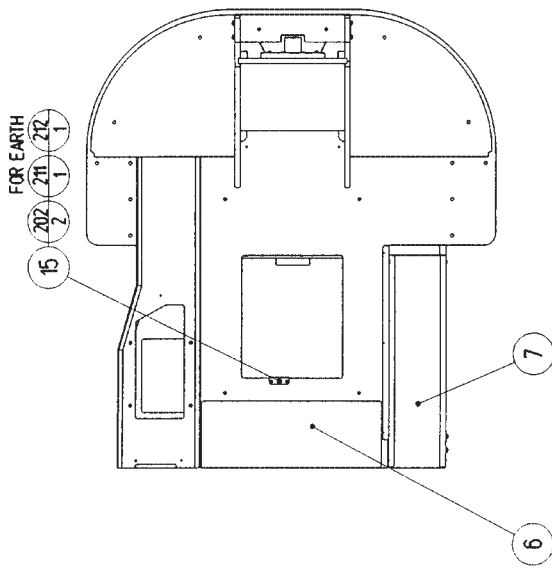
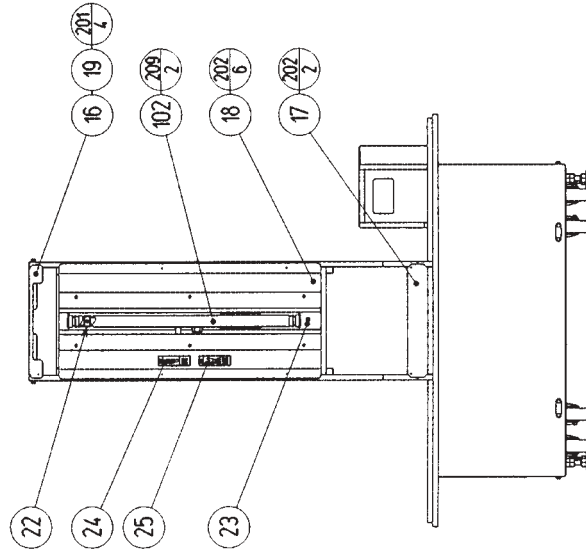
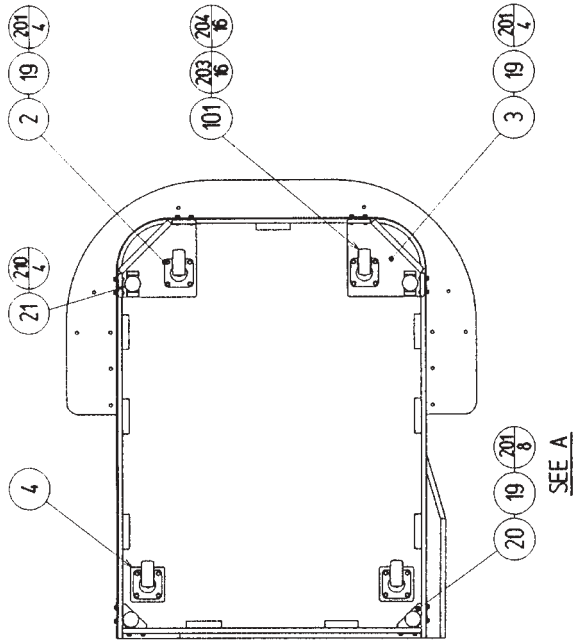



24 ASSY REAR SUB-CABI (FRI-3001)

( D-2/2 )

ITEM NO.	PART NO.	DESCRIPTION	NOTE
1	FRI-3002	REAR CABINET	
2	FRI-3003	CORNER BRKT L	
3	FRI-3004	CORNER BRKT R	
4	FRI-1009	CASTER SPACER PLATE	
5	FRI-3010	FR CONN PNL	
6	FRI-3013	FOOT PLATE	
7	FRI-3022	MAT A	
9	FRI-3024	SASH A	
10	FRI-3025	SASH B	
11	FRI-3026	SASH C	
12	FRI-3027	SASH D	
15	FRI-3033	SP PNL BRKT	
16	FRI-3011	HOLDER Z UPPER	
17	FRI-3012	HOLDER Z LOWER	
18	FRI-3102	REFLECTOR	
19	117-5233	PLATE LEG BRACKET BLACK	
20	ARC-1006	LEG BRACKET	
21	601-5699X	LEG ADJUSTER BOLT M16 X 75	
22	253-5457	FL HOLDER	
23	421-7501-09	STICKER FL30W	
24	440-WS0002XEG	STICKER W POWER OFF ENG	
25	440-WS0012XEG	STICKER W HIGH TEMP ENG	
101	601-9377	CASTER FAI=75	
102	390-6603-30EX	ASSY FL30W EX W/CONN HIGH T CE	
103	280-5009-01	CORD CLAMP 21	
201	030-000630-SB	HEX BLT BLK W/S M6 X 30	
202	000-P00416-W	M SCR PH W/FS M4 X 16	
203	030-000630-S	HEX BLT W/S M6 X 30	
204	060-F00600	FLT WSHR M6	
206	079-000008	SCR NAIL THH STNLS 1.5 X 16	
207	000-T00416-0C	M SCR TH CRM M4 X 16	
209	000-P00430-W	M SCR PH W/FS M4 X 30	
210	050-H01600	HEX NUT M16	
211	000-P00408-S	M SCR PH W/S M4 X 8	
212	060-F00400	FLT WSHR M4	
301	FRI-6003	ASSY WIRE REAR	
303	FRI-60072X	WIRE HARN EXT AC REAR A	
304	FRI-60079X	WIRE HARN CENTER TOWER AC	
305	FRI-60080	WIRE HARN CENTER TOWER DC	
306	600-6972-0600	WIRE HARN EARTH ID5 0600MM	
307	600-6972-1000	WIRE HARN EARTH ID5 1000MM	

②5 ASSY WIRE REAR (FRI-6003)

ASSY WIRE REAR is comprised of the following wire harnesses.  
An ASSY DRG. is unavailable.

ITEM NO.	PART NO.	DESCRIPTION	NOTE
101	601-0460	PLASTIC TIE BELT 100 MM	
301	FRI-60065	WIRE HARN EXT REAR CTRL B	
302	FRI-60066	WIRE HARN EXT SHIFT LOCK B	
303	FRI-60067	WIRE HARN EXT SEAT SP B	
304	FRI-60070	WIRE HARN EXT BASS SP	
305	FRI-60073	WIRE HARN EXT BRAKE LAMP B	

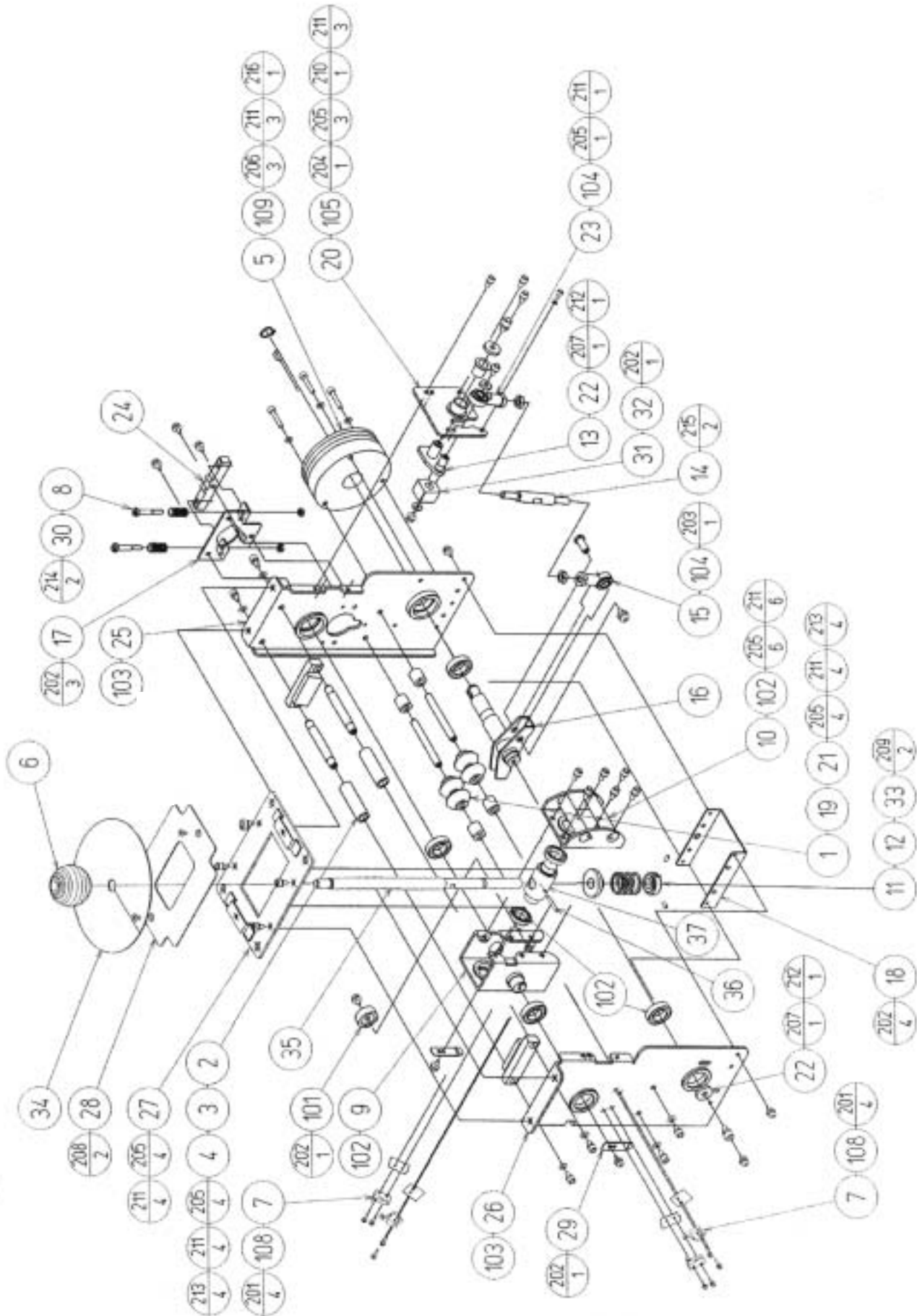

26 ASSY 6SPEED SHIFTER (FRI-2150)

( D-2/3 )

ITEM NO.	PART NO.	DESCRIPTION	NOTE
1	FRI-2151	ROLLER PIN	
2	FRI-2152	STP RUBBER PIN	
3	FRI-2153	STOPPER RUBBER	
4	FRI-2154	SIDE GUARD	
5	FRI-2155	KEY	
6	FRI-2156	KNOB	
7	SPG-2159	INSULATOR SHEET	
8	FRI-2158	CENTERING SPRING	
9	FRI-2159	SHAFT CASE F	
10	FRI-2160	SHAFT CASE R	
11	FRI-2161	CENTERING HEAD	
12	FRI-2162	SPRING BRKT	
13	FRI-2163	HOLDER	
14	FRI-2164	CLUTCH BAR	
15	FRI-2165	CLUTCH PIN	
16	FRI-2166	CLUTCH SHAFT	
17	FRI-2167	CENTERING BRKT	
18	FRI-2168	CR SPRING BRKT	
19	FRI-2169	GUIDE ROLLER	
20	FRI-2170	CENTER PLATE	
21	FRI-2171	COLLAR	
22	FRI-2172	COLLAR 18	
23	FRI-2173	COLLAR 14	
24	FRI-2174	CENTERING POSITION	
25	FRI-2175	SIDE PLATE B	
26	FRI-2176	SIDE PLATE A	
27	FRI-2177	PLATE BRKT	
28	FRI-2178	SLIDE PLATE BASE	
29	FRI-2179	SW DOG	
30	FRI-2180	SP GUIDE SHAFT	
31	FRI-2181	RUBBER BEAM	
32	FRI-2182	RUBBER	
33	FRI-2183	COMPRESSION SPRING	
34	FRI-2184	SLIDE PLATE	
35	FRI-2157	SHIFT SHAFT	
36	045-SU0424-Z	M4 X 24 SPRING PIN	
37	123-5107	SHAFT PIN G5042-8020 FRI	
101	100-5252	BEARING ROLLER 25	
102	100-5360	BEARING 17	
103	100-5229	BEARING 17	
104	100-5361	RODEND 8	
105	100-5362	BEARING 12	
106	601-10805	TIE BELT	
107	280-5275-SR10	CORD CLAMP SR10	
108	509-5636	SW MICRO TYPE SS-5GL2T	
109	601-10806	BRAKE BXH-08	

26 ASSY 6SPEED SHIFTER (FRI-2150)

( D-3/3 )

ITEM NO.	PART NO.	DESCRIPTION	NOTE
201	FAS-000033	M SCR PH W/FS M2.3 X 12	
202	000-P00408-W	M SCR PH W/FS M4 X 8	
203	000-P00510-W	M SCR PH W/FS M5 X 10	
204	020-000410-0Z	HEX SKT H CAP SCR BLK OZ M4 X 10	
205	020-000510-0Z	HEX SKT H CAP SCR BLK OZ M5 X 10	
206	020-000525-0Z	HEX SKT H CAP SCR BLK OZ M5 X 25	
207	FAS-200037	HEX SKT H CAP SCR BLK OZ M6 X 15	
208	000-F00406	M SCR FH M4 X 6	
209	028-A00406-P	SET SCR HEX SKT CUP P M4 X 6	
210	060-S00400	SPR WSHR M4	
211	060-S00500	SPR WSHR M5	
212	060-S00600	SPR WSHR M6	
213	060-F00500	FLT WSHR M5	
214	050-U00500	U NUT M5	
215	050-H00800	HEX NUT M8	
216	065-S014S0-Z	STP RING BLK OZ S14	
301	FRI-60094	WIRE HARN SHIFT SW	

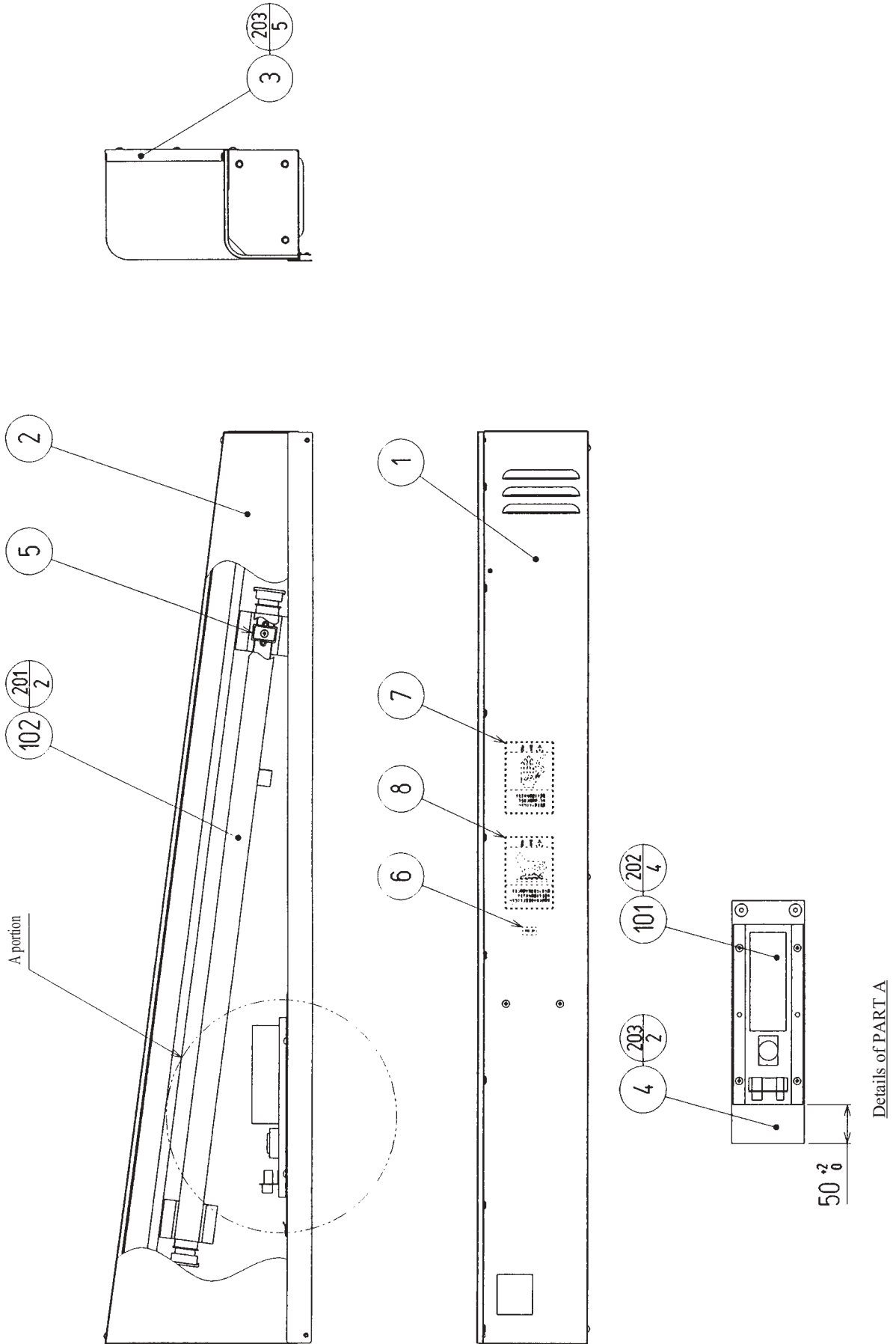

27 ASSY SIDE TOWER L (FRI-3050)

( D-2/2 )

ITEM NO.	PART NO.	DESCRIPTION	NOTE
1	FRI-3051	SIDE TOWER L	
2	FRI-3052	SIDE FL COVER L	
3	FRI-3053	SASH FRONT L	
4	FRI-3054	WOODEN BASE FOR BRST	
5	253-5457	FL HOLDER	
6	421-7501-18	STICKER FL32W	
7	440-WS0002XEG	STICKER W POWER OFF ENG	
8	440-WS0012XEG	STICKER W HIGH TEMP ENG	
101	390-6649-32	GLOW&BALLAST UNIT 1P 32W	
102	390-6650-32EX	FL 32WEX W/CONN LOW W/O G&B	
201	000-T00425-0B	M SCR TH BLK M4 X 25	
202	011-T00312	TAP SCR TH 3 X 12	
203	000-T00412-0B	M SCR TH BLK M4 X 12	
301	FRI-60084	WIRE HARN SIDE TOWER L INV IN	
302	FRI-60085	WIRE HARN SIDE TOWER L FL	

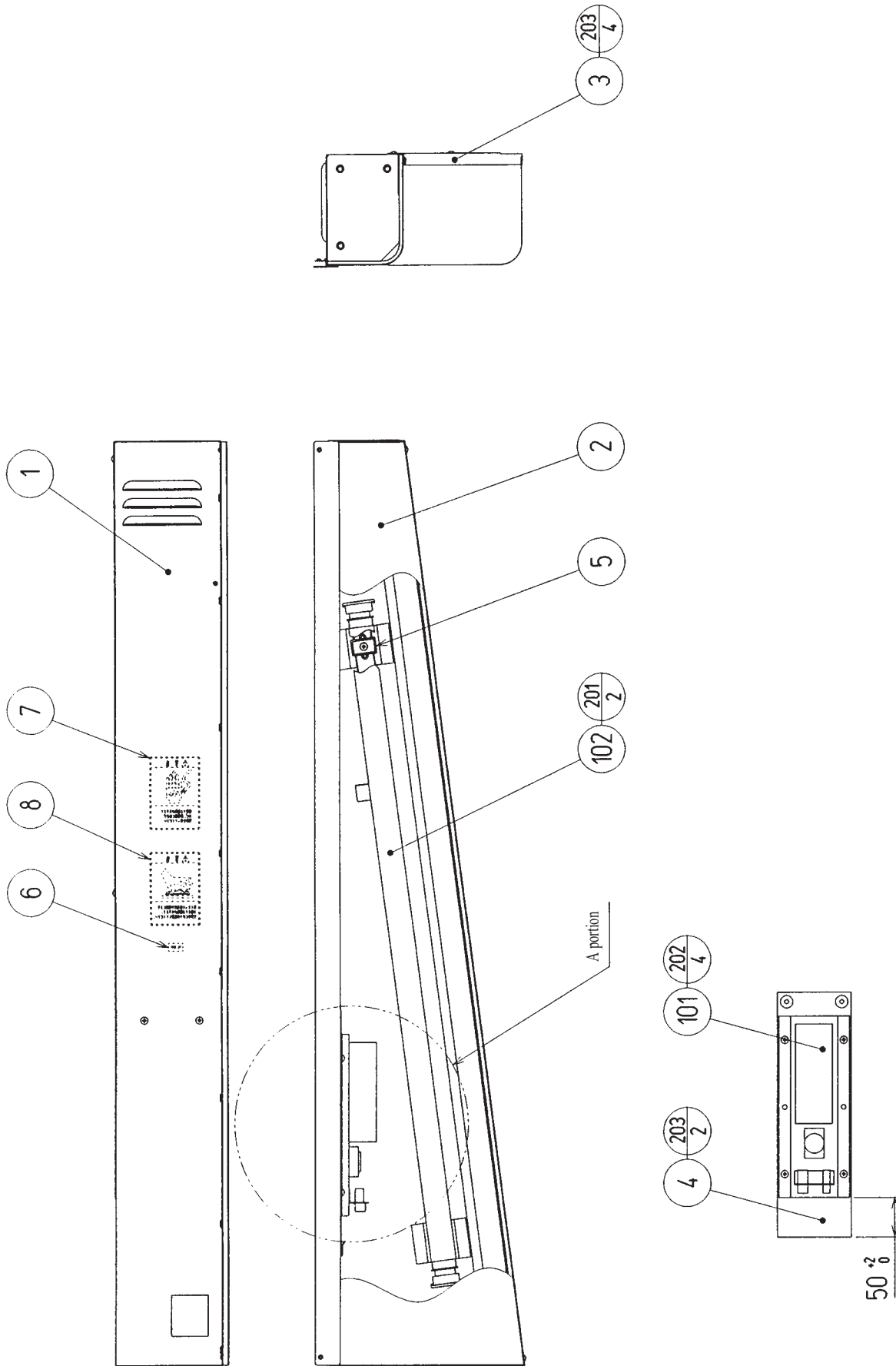

Details of PART A



28 ASSY SIDE TOWER R (FRI-3060)

( D-2/2 )

ITEM NO.	PART NO.	DESCRIPTION	NOTE
1	FRI-3061	SIDE TOWER R	
2	FRI-3062	SIDE FL COVER R	
3	FRI-3063	SASH FRONT R	
4	FRI-3054	WOODEN BASE FOR BRST	
5	253-5457	FL HOLDER	
6	421-7501-18	STICKER FL32W	
7	440-WS0002XEG	STICKER W POWER OFF ENG	
8	440-WS0012XEG	STICKER W HIGH TEMP ENG	
101	390-6649-32	GLOW&BALLAST UNIT 1P 32W	
102	390-6650-32EX	FL 32WEX W/CONN LOW W/O G&B	
201	000-T00425-0B	M SCR TH BLK M4 X 25	
202	011-T00312	TAP SCR TH 3 X 12	
203	000-T00412-0B	M SCR TH BLK M4 X 12	
301	FRI-60076	WIRE HARN SIDE TOWER R INV IN	
302	FRI-60077	WIRE HARN SIDE TOWER R FL	

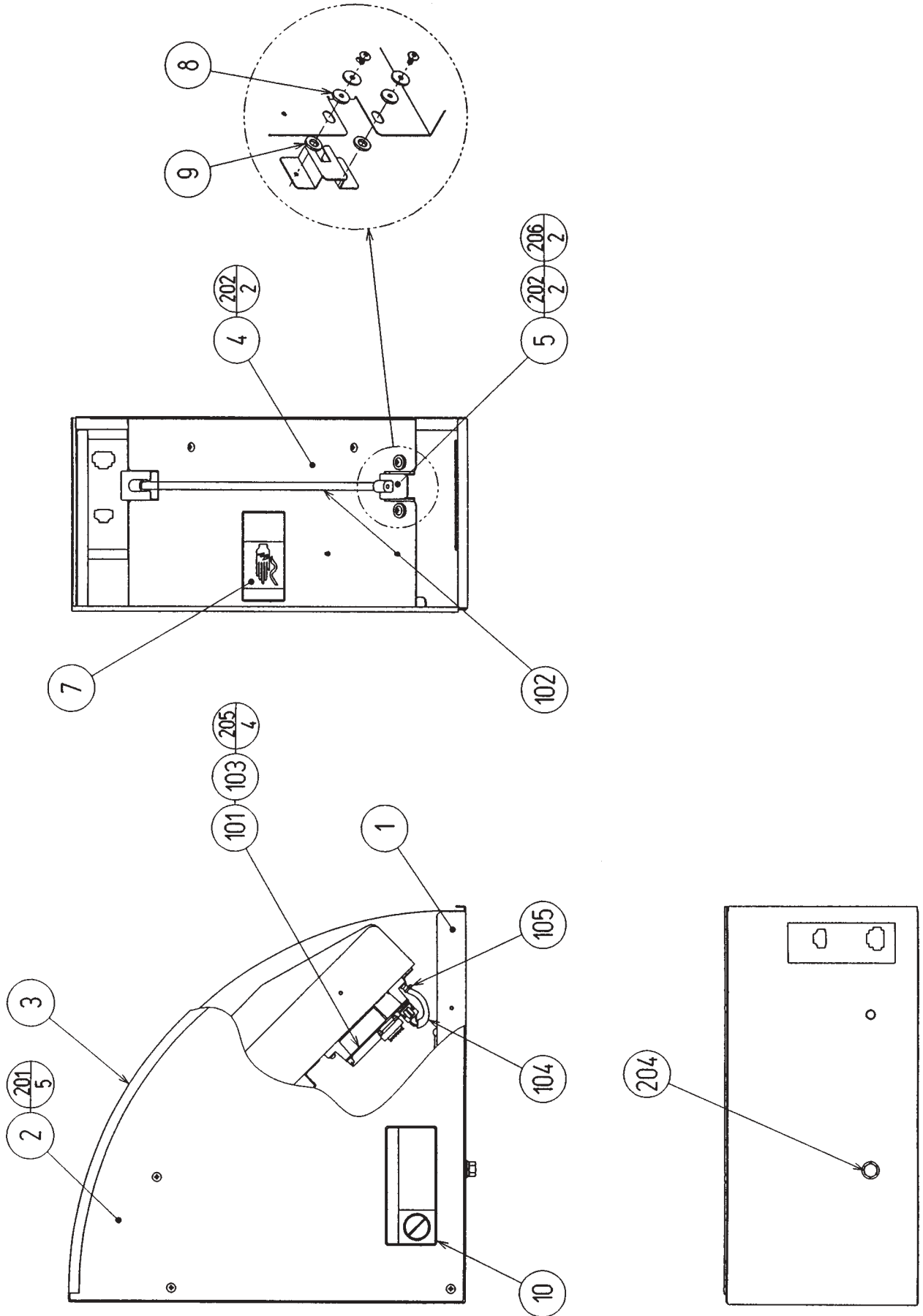

29 ASSY CORNER LIGHT L (FRI-3100)

( D-2/2 )

ITEM NO.	PART NO.	DESCRIPTION	NOTE
1	FRI-3151	CORNER LIGHT BOX	
2	FRI-3152	CORNER LIGHT LID	
3	FRI-3153X	LID EDGE PACKING	
4	FRI-3154	CORNER REFLECTOR	
5	FRI-3155	LIGHT HOLDER	
7	440-WS0002XEG	STICKER W POWER OFF ENG	
8	FRI-3158	LIGHT HOLDER BUSH	
9	FRI-3159	LIGHT HOLDER SPACER	
10	440-CS0180-EG	STICKER C KEEP OUT ENG	
101	400-5414	INVERTER FIP24-12N-UX	
102	390-6651	EXT ELECTRODE CFX12AYG/36H	
103	601-7467	L-LOCK BK	
104	310-5047-6H0014	VINYL TUBE 6H-0014CM	
105	601-0460	PLASTIC TIE BELT 100 MM	
201	000-T00408-0B	M SCR TH BLK M4 X 8	
202	000-T00412-0C	M SCR TH CRM M4 X 12	
204	030-000816-SB	HEX BLT W/S BLK M8 X 16	
205	000-P00312-W	M SCR PH W/FS M3 X 12	
206	068-441616-0C	FLT WSHR CRM 4.4-16 X 1.6	
301	FRI-60082X	WIRE HARN CORNER L AC	
302	FRI-60083	WIRE HARN BRAKE LAMP L	

30 ASSY CORNER LIGHT R (FRI-3150)

( D-1/2 )

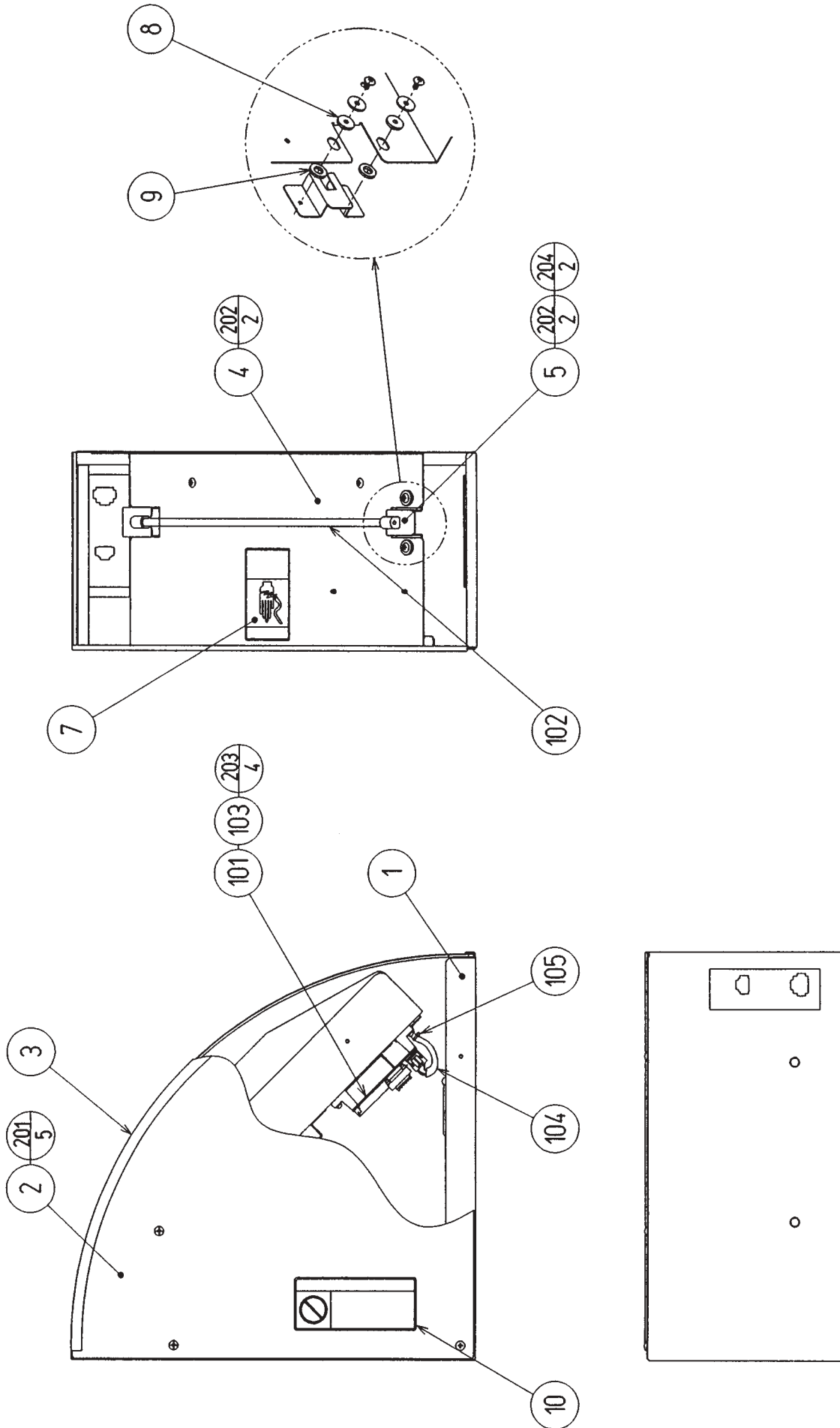

③0 ASSY CORNER LIGHT R (FRI-3150)

( D-2/2 )

ITEM NO.	PART NO.	DESCRIPTION	NOTE
1	FRI-3151	CORNER LIGHT BOX	
2	FRI-3152	CORNER LIGHT LID	
3	FRI-3153X	LID EDGE PACKING	
4	FRI-3154	CORNER REFLECTOR	
5	FRI-3155	LIGHT HOLDER	
7	440-WS0002XEG	STICKER W POWER OFF ENG	
8	FRI-3158	LIGHT HOLDER BUSH	
9	FRI-3159	LIGHT HOLDER SPACER	
10	440-CS0180-EG	STICKER C KEEP OUT ENG	
101	400-5414	INVERTER FIP24-12N-UX	
102	390-6651	EXT ELECTRODE CFX12AYG/36H	
103	601-7467	L-LOCK BK	
104	310-5047-6H0014	VINYL TUBE 6H-0014CM	
105	601-0460	PLASTIC TIE BELT 100 MM	
201	000-T00408-0B	M SCR TH BLK M4 X 8	
202	000-T00412-0C	M SCR TH CRM M4 X 12	
203	000-P00312-W	M SCR PH W/FS M3 X 12	
204	068-441616-0C	FLT WSHR CRM 4.4-16 X 1.6	
301	FRI-60075X	WIRE HARN CORNER R AC	
302	FRI-60078	WIRE HARN BRAKE LAMP R	

31 ASSY REAR ROOF (FRI-3200)

(D-1/2)

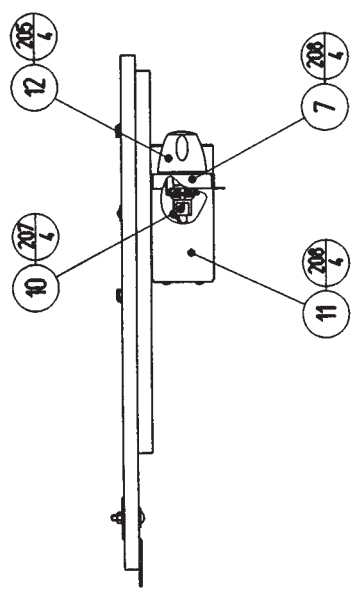
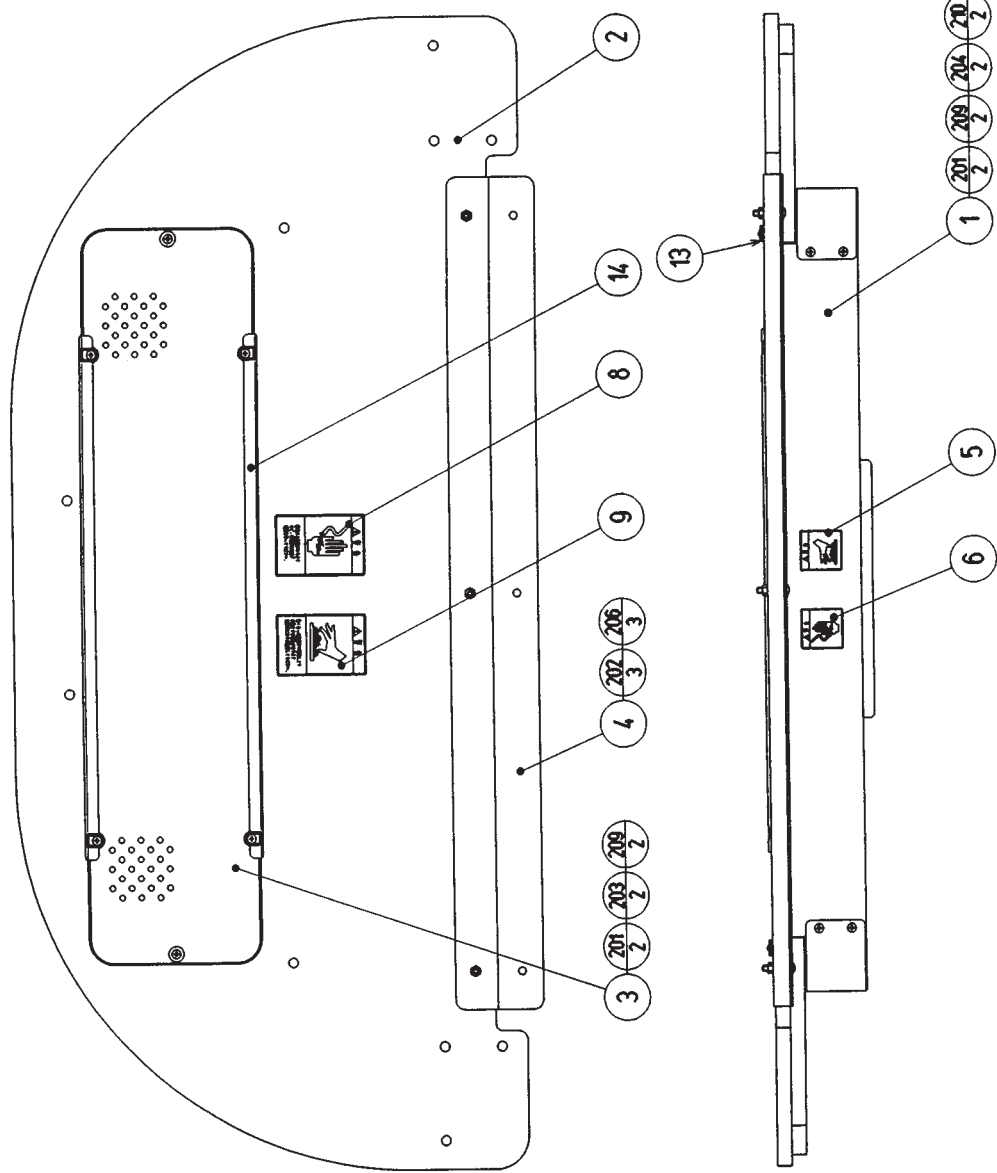

31 ASSY REAR ROOF (FRI-3200)

( D-2/2 )

ITEM NO.	PART NO.	DESCRIPTION	NOTE
1	FRI-3250	ASSY TOP LIGHT	
2	FRI-3201	REAR ROOF	
3	FRI-3202X	FL PLATE	
4	FRI-3203	ROOF BRKT REAR	
8	440-WS0002XEG	STICKER W POWER OFF ENG	
9	440-WS0012XEG	STICKER W HIGH TEMP ENG	
10	FRI-3207	LAMP BLIND LID	
13	FRI-3158	LIGHT HOLDER BUSH	
14	FRI-3208	PLATE HOLDER	
201	000-T00416-0B	M SCR TH BLK M4 X 16	
202	000-T00630-0B	M SCR TH BLK M6 X 30	
203	060-F00400-0B	FLT WSHR BLK M4	
204	050-C00400-3B	CAP NUT TYPE3 BLK M4	
206	068-652016-0B	FLT WSHR BLK 6.5-20 X 1.6	
208	000-T00408-0B	M SCR TH BLK M4 X 8	
209	068-441616-0B	FLT WSHR BLK 4.4-16 X 1.6	
210	000-T00420-0B	M SCR TH BLK M4 X 20	

③② ASSY TOP LIGHT (FRI-3250)

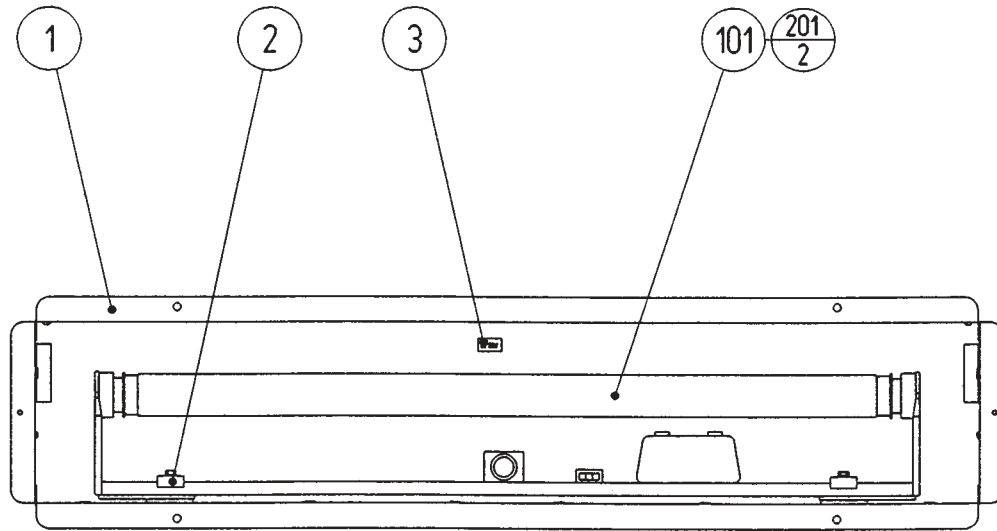

ITEM NO.	PART NO.	DESCRIPTION	NOTE
1	FRI-3251	TOP FL BOX	
2	253-5457	FL HOLDER	
3	421-7501-17	STICKER FL 20W	
101	390-6603-20EX	ASSY FL20W EX W/CONN HIGH T CE	
201	050-F00400	FLG NUT M4	
301	FRI-60081X	WIRE HARN BILLBOARD FL	



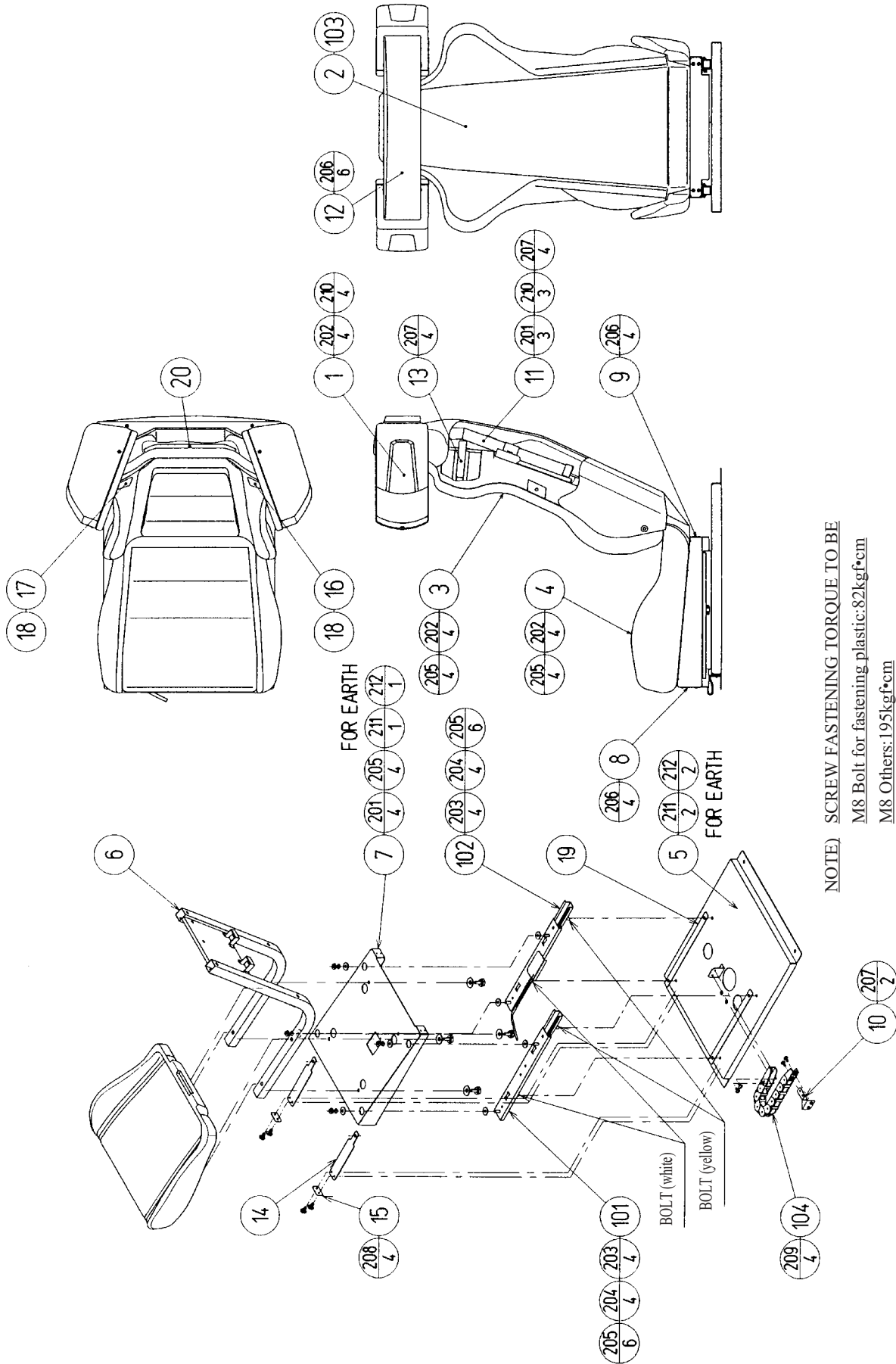

33 ASSY SEAT (FRI-3300)

( D-2/2 )

ITEM NO.	PART NO.	DESCRIPTION	NOTE
1	FRI-3350	SOUND UNIT	
2	FRI-3301	SEAT BACK COVER	
3	FRI-3302	UPPER SEAT	
4	FRI-3303	LOWER SEAT	
5	FRI-3304	SEAT BASE	
6	FRI-3305	SEAT FRAME	
7	FRI-3306	SEAT SLANT TRAY	
8	FRI-3307	FRONT TRAY COVER	
9	FRI-3308	REAR TRAY COVER	
10	FRI-3309	CABLE BEAR BRKT	
11	FRI-3310	SPEAKER SUPPORT	
12	FRI-3312	ARM REAR COVER	
13	FRI-3313	GULL PLATE	
14	SRT-2408	PROTECT RUBBER	
15	SPG-2411	RUBBER PLATE	
16	STC-1608	SPEAKER NET L	
17	STC-1609	SPEAKER NET R	
18	SRT-2409	SHOULDER PAD	
19	117-5414	PLATE S RAIL LOWER	
20	FRI-3314	HEAD CUSION	
101	601-9059-91	SEAT RAIL L	
102	601-9060-91	SEAT RAIL R	
103	280-5297	SCRIVET 8 1K31	
104	601-6981-009	CABLE BEAR L=009	
105	280-5009-01	CORD CLAMP 21	
106	280-5275-SR10	CORD CLAMP SR10	
201	030-000816-S	HEX BLT W/S M8 X 16	
202	030-000850-S	HEX BLT W/S M8 X 50	
203	050-H00800	HEX NUT M8	
204	060-S00800	SPR WSHR M8	
205	068-852216	FLT WSHR 8.5-22 X 1.6	
206	000-T00408-0B	M SCR TH BLK M4 X 8	
207	000-P00410-W	M SCR PH W/FS M4 X 10	
208	000-T00516-0B	M SCR TH BLK M5 X 16	
209	000-T00616-0B	M SCR TH BLK M6 X 16	
210	060-F00800	FLT WSHR M8	
211	000-P00408-S	M SCR PH W/S M4 X 8	
212	060-F00400	FLT WSHR M4	
301	FRI-60068	WIRE HARN EXT SEAT SP C	
302	600-6972-0600	WIRE HARN EARTH ID5 0600MM	

34 SOUND UNIT (FRI-3350)

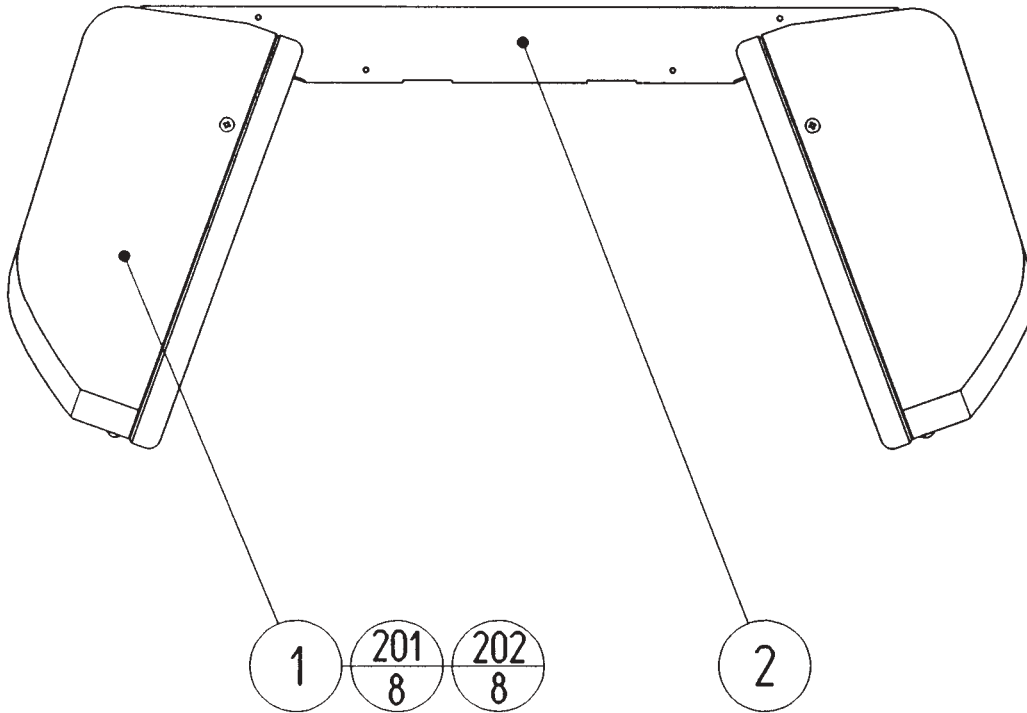

ITEM NO.	PART NO.	DESCRIPTION	NOTE
1	FRI-3360	ASSY SPEAKER	
2	FRI-3351	MOUNT ARM	
101	280-5275-SR10	CORD CLAMP SR10	
201	030-000816-S	HEX BLT W/S M8 X 16	
202	060-F00800	FLT WSHR M8	

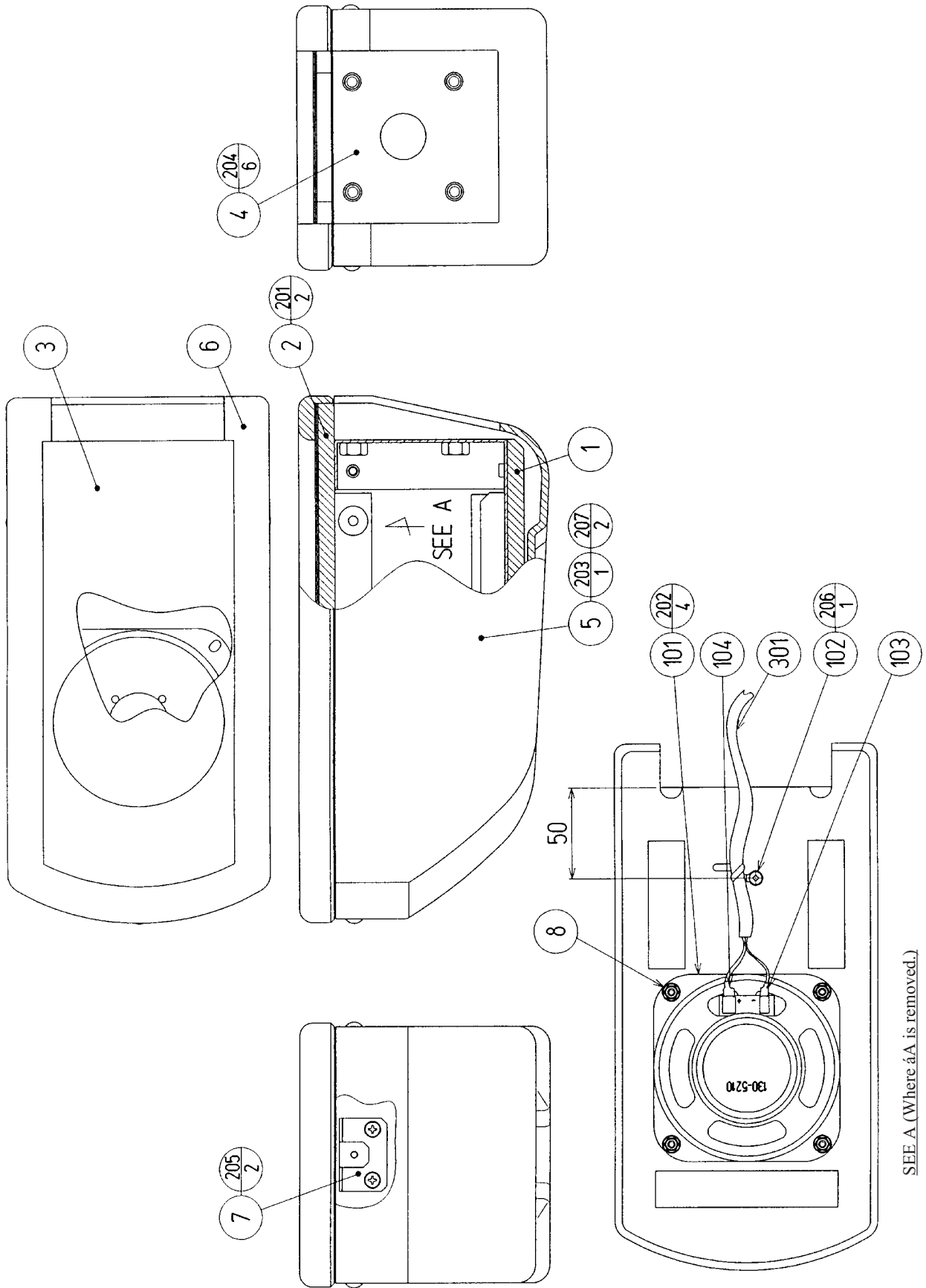

35 ASSY SPEAKER (FRI-3360)

( D-2/2 )

ITEM NO.	PART NO.	DESCRIPTION	NOTE
1	FRI-3361	ENCLOSURE	
2	FRI-3362	BAFFLE	
3	FRI-3363	SPEAKER NET	
4	FRI-3364	HOLDER	
5	FRI-3365	COVER	
6	FRI-3366X	EDGE GUARD	
7	FRI-3367	COVER BRKT	
8	FRI-3368	SPEAKER BUSH	
101	130-5210	SPKR 4INCH 4OHM 12W25W	
102	280-0419	HARNESS LUG	
103	310-5029-F20	SUMITUBE F F 20MM	
104	310-5029-H20	SUMITUBE F H 20MM	
201	000-P00430-W	M SCR PH W/FS M4 X 30	
202	050-F00400	FLG NUT M4	
203	000-T00416-0B	M SCR TH BLK M4 X 16	
204	000-F00516	M SCR FH M5 X 16	
205	000-P00412-W	M SCR PH W/FS M4 X 12	
206	011-T03510	TAP SCR TH 3.5 X 10	
207	000-T00430-0B	M SCR TH BLK M4 X 30	
301	FRI-60069	WIRE HARN SEAT SP	

③⑥ ASSY EFACT SW (FRI-3400)

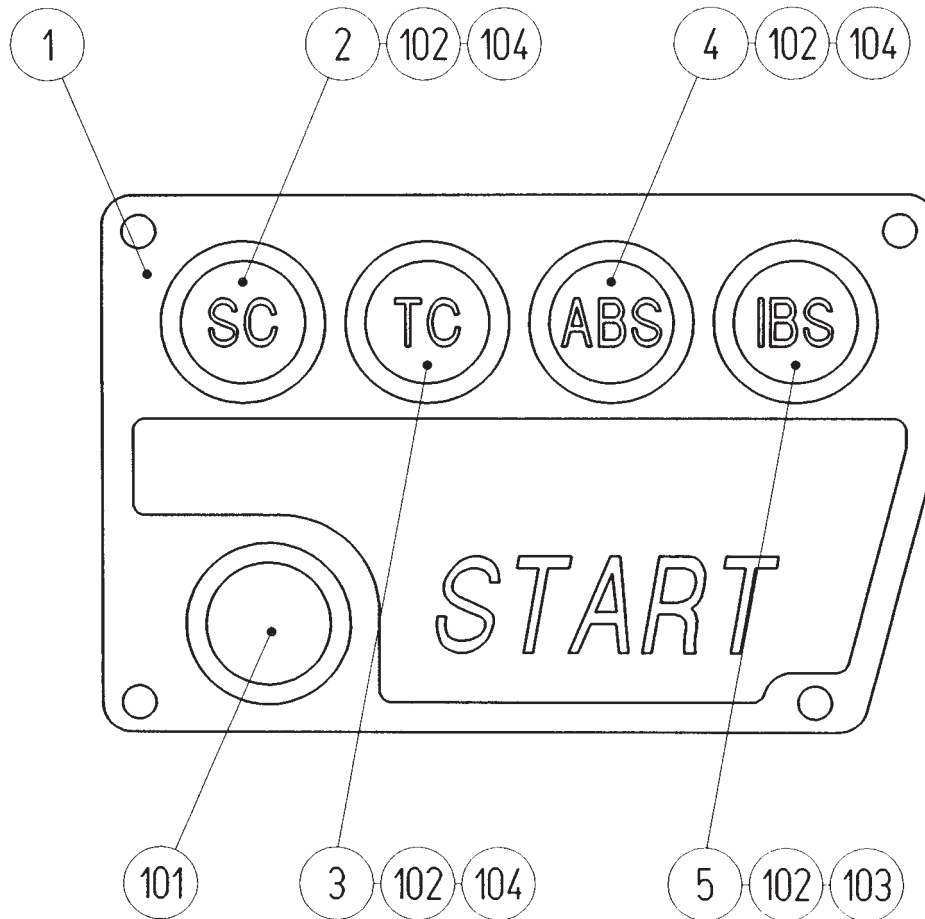

ITEM NO.	PART NO.	DESCRIPTION	NOTE
1	FRI-3401	SW PLATE	
2	FRI-3402	BUTTON SHEET SC	
3	FRI-3403	BUTTON SHEET TC	
4	FRI-3404	BUTTON SHEET ABS	
5	FRI-3405	BUTTON SHEET IBS	
101	509-5838-Y	SW PB LW1L-15Y-TK1670	
102	509-5653	PB W/L 6V W/O LEN, PLT 1L110	
103	253-5380-04	BUTTON COVER 1L BL	
104	253-5380-02	BUTTON COVER 1L GR	
301	FRI-60074	WIRE HARN EFFECT SW	

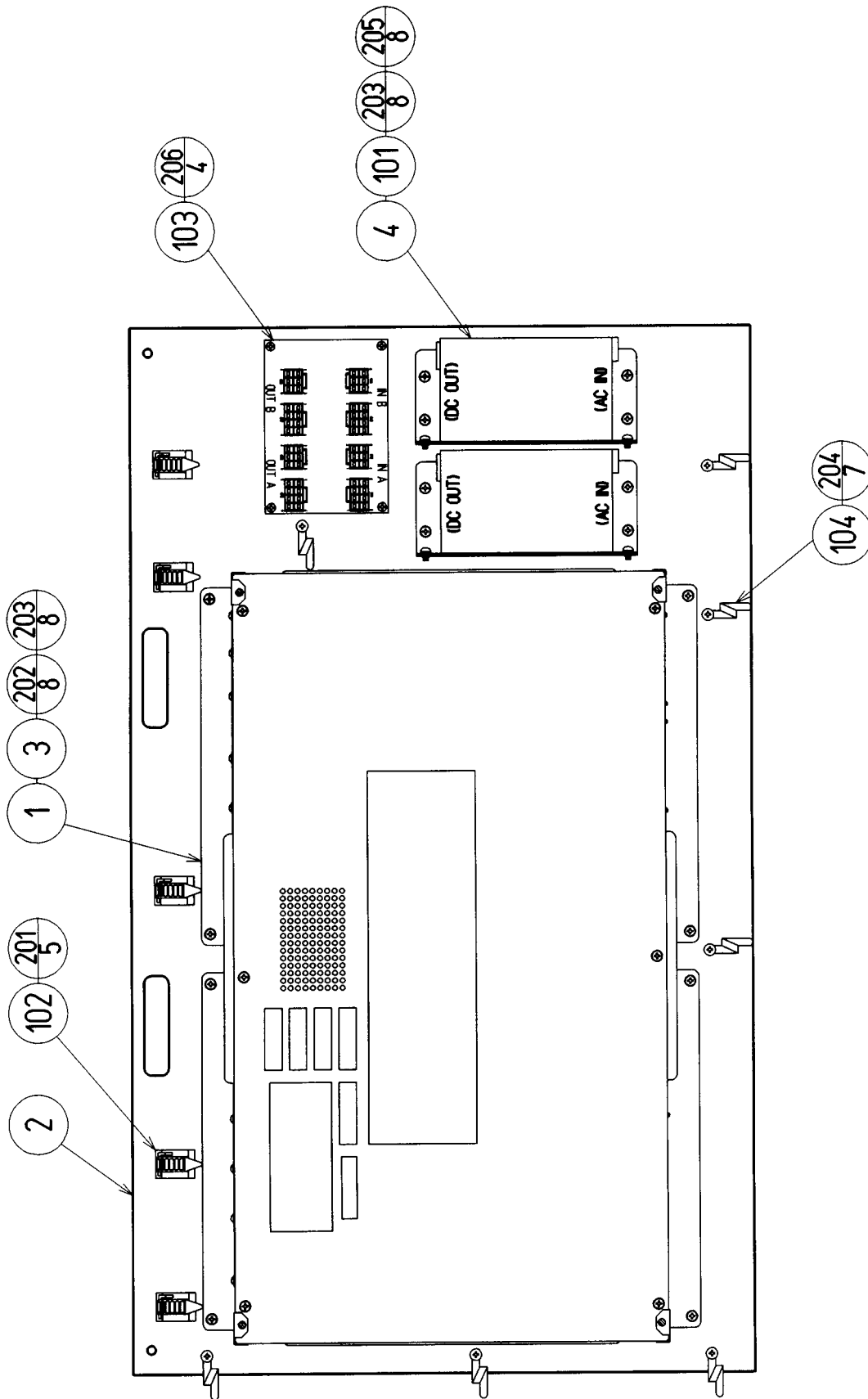

③7 ASSY MAIN BD DX (FRI-4000)

( D-2/2 )

ITEM NO.	PART NO.	DESCRIPTION	NOTE
1	FRI-4050 ~	ASSY SHIELD CASE FRI ~	
2	APC-4001	WOODEN MAIN BASE	
3	105-5368	SHIELD CASE BRKT	
4	APC-4002	SW REGU BRKT	
101	400-5397	SW REGU FOR JVS	
102	280-5009-01	CORD CLAMP 21	
103	838-13760	DC SEQUENCE BD	
104	280-0419	HARNESS LUG	
105	601-0460	PLASTIC TIE BELT 100 MM	
106	270-5052-04	L.FILTER D	
201	011-F00310	TAP SCR FH 3 X 10	
202	000-P00408-W	M SCR PH W/FS M4 X 8	
203	000-P00412-W	M SCR PH W/FS M4 X 12	
204	011-T03512	TAP SCR TH 3.5 X 12	
205	000-P00406-W	M SCR PH W/FS M4 X 6	
206	011-P00325	TAP SCR PH 3 X 25	
301	FRI-60017	WIRE HARN MAIN BD AC IN	
302	FRI-60018	WIRE HARN MAIN BD DC OUT	
303	FRI-60019	WIRE HARN MAIN BD DC A	
304	FRI-60020	WIRE HARN MAIN BD DC B	
305	FRI-60021	WIRE HARN MAIN BD DC C	
306	FRI-60022	WIRE HARN MAIN BD DC D	



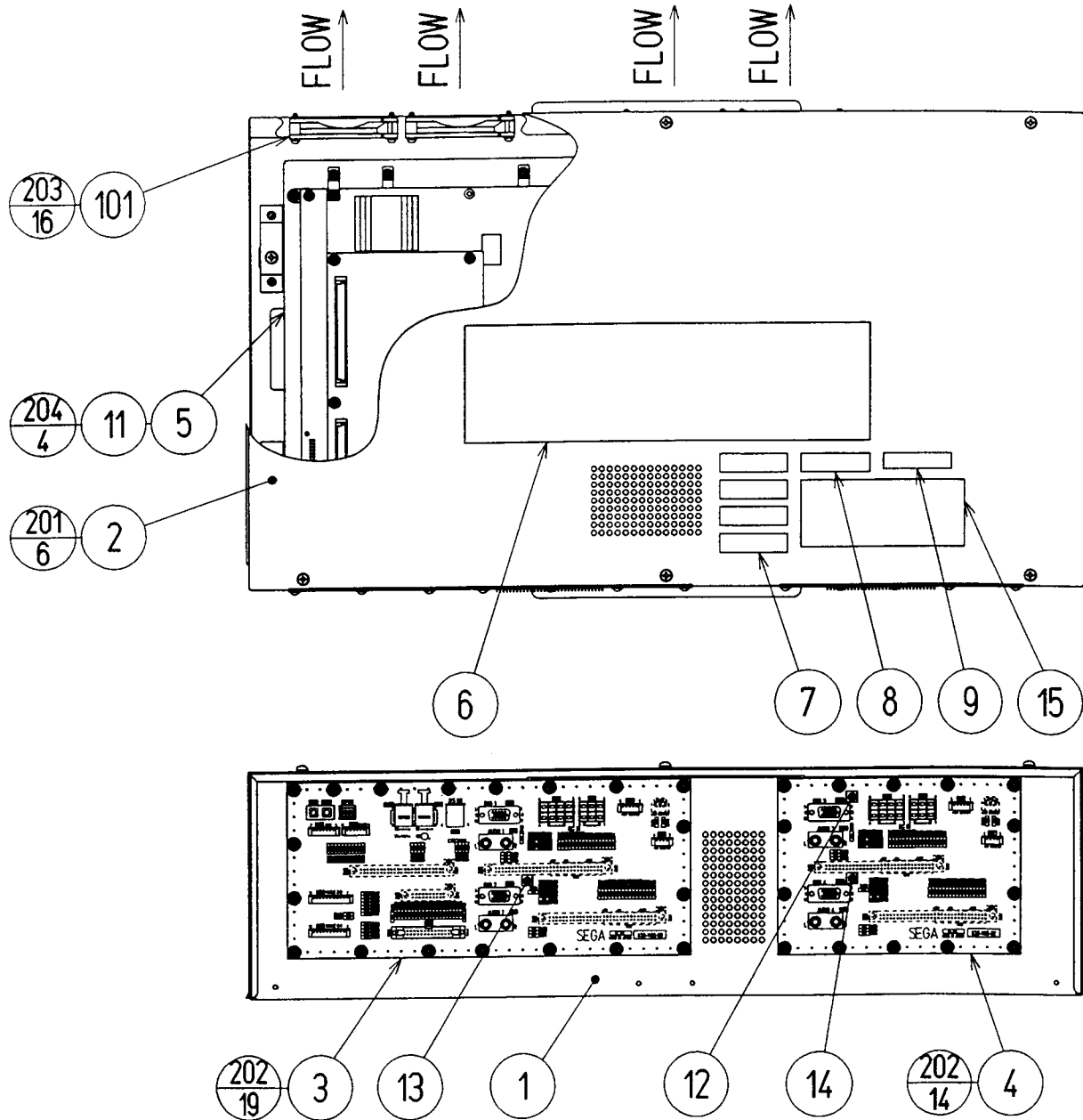

③8 ASSY SHIELD CASE FRI ~ (FRI-4050 ~ )

( D-2/2 )

ITEM NO.	PART NO.	DESCRIPTION	NOTE
1	105-5366	SHIELD CASE NAOMI MULTI	
2	105-5367	SHIELD CASE LID NAOMI MULTI	
3	839-1109-02	FLT BD NAOMI MULTI MASTER FRI	
4	839-1110-02	FLT BD NAOMI MULTI SLAVE FRI	
5	833-13841 ~	GAME BD FRI DX ~	
6	421-9174-01	STICKER CAUTION ANTISTATIC	
7	421-10023-AAA	STICKER BD SERIAL NUMBER AAA	
8	421-10023-BAM	STICKER BD SERIAL NUMBER BAM	
9	441-313841	STICKER 833-13841	
10	601-10577	CARTON BOX NAOMI MULTI	
11	105-5390	FIXING BRACKET	
12	421-9757-L	STICKER L	
13	421-9757-C	STICKER C	
14	421-9757-R	STICKER R	
101	260-0064	FAN MOTOR DC12V	
102	280-5275-SR10	CORD CLAMP SR10	
103	601-0460	PLASTIC TIE BELT 100 MM	
201	000-P00408-W	M SCR PH W/FS M4 X 8	
202	010-P00308-F	S-TITE SCR PH W/F M3 X 8	
203	000-P00320-W	M SCR PH W/FS M3 X 20	
204	000-P00412-W	M SCR PH W/FS M4 X 12	
301	APC-60045	WIRE HARN FAN MOTOR MASTER	
302	APC-60046	WIRE HARN FAN MOTOR SLAVE	

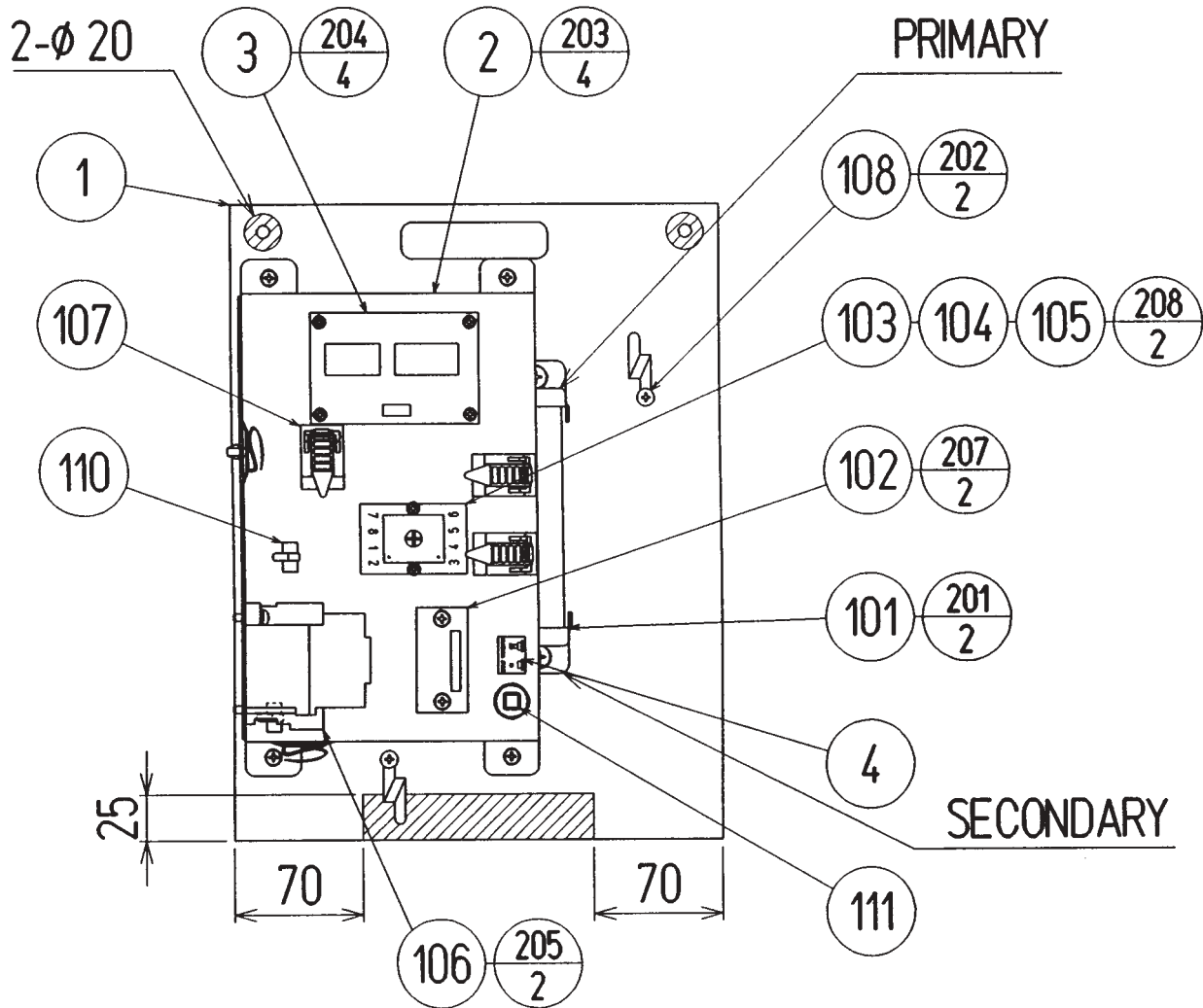

- Note) 1. 450-5163 ((103)) should be set to 3 sec.  
 2. Make sure that there is no wiring, etc. in the slash mark portions.

③9 ASSY PWR SPLY DX (FRI-4100)

( D-2/2 )

ITEM NO.	PART NO.	DESCRIPTION	NOTE
1	FRI-4101	WOODEN PWR SPLY BASE	
2	FRI-4102	PWR SPLY BRKT	
3	839-0976	CONN BD	
4	421-7468-01	STICKER C.P W/PIC	
101	560-5430-H	XFMR 100-120V 100V 15A WB	AC 110 ~ 120V AREA
	560-5431-H	XFMR 220-240V 100V 15A WB	AC 220 ~ 240V AREA
102	117-5225	TERMINAL 3P 20A	
103	450-5163	TIMER RELAY GT5P-N30SA100	
104	214-0191	RELAY SOCKET	
105	601-7783	FIXED SPRING	
106	450-5126	MAGNET CONTACT S-NIOCX	
107	280-5169	CORD CLAMP TL-20S	
108	280-0419	HARNESS LUG	
110	280-5275-SR10	CORD CLAMP SR10	
111	512-5046-15000	C.P 15000MA CE UL	
201	000-P00512-W	M SCR PH W/FS M5 X 12	
202	011-T03512	TAP SCR TH 3.5 X 12	
203	000-P00412-W	M SCR PH W/FS M4 X 12	
204	000-P00320-W	M SCR PH W/FS M3 X 20	
205	000-P00416-W	M SCR PH W/FS M4 X 16	
207	000-P00416-S	M SCR PH W/S M4 X 16	
208	000-P00325-W	M SCR PH W/FS M3 X 25	
301	FRI-60009	WIRE HARN XFMR IN	
302	FRI-60010	WIRE HARN XFMR OUT	
303	FRI-60011	WIRE HARN MAG CONT IN	
304	FRI-60012	WIRE HARN TIMER A	
305	FRI-60013	WIRE HARN TIMER B	
306	FRI-60014	WIRE HARN TIMER C	
307	FRI-60015	WIRE HARN MAG CONT OUT	
308	FRI-60016	WIRE HARN PWR SPLY OUT A	
310	FRI-60007	WIRE HARN PWR SPLY OUT B	

④ ASSY I/O BASE DX (FRI-4200)

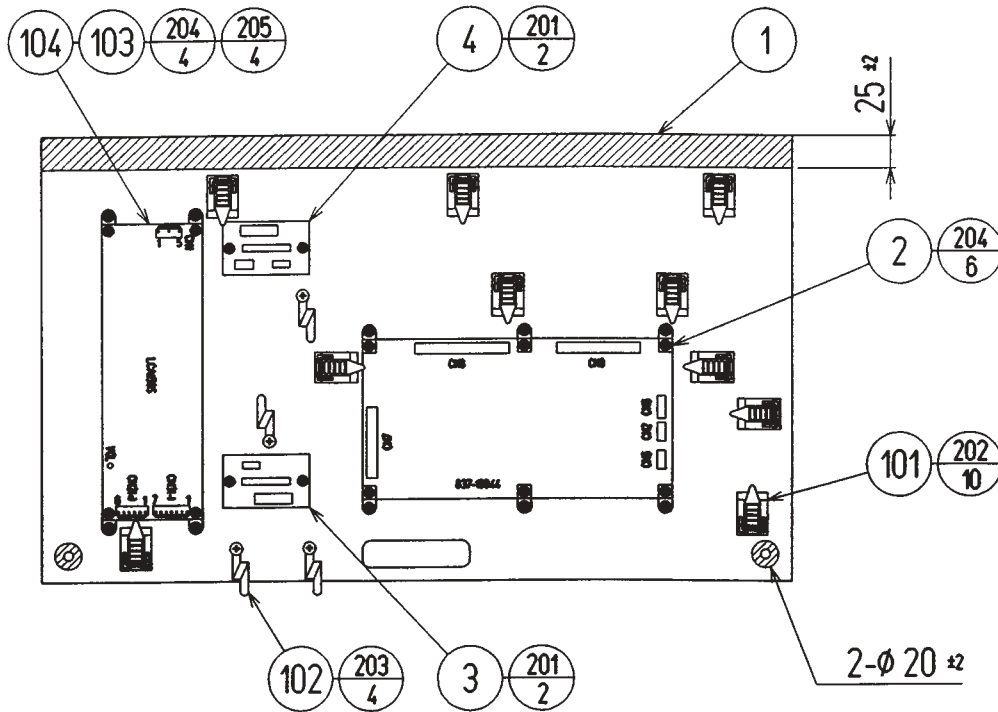

NOTE) Make sure that there is no wiring, etc.  
in the slash mark portions.

ITEM NO.	PART NO.	DESCRIPTION	NOTE
1	APC-4201	WOODEN I/O BASE	
2	837-13844	I/O CONTROL BD 2 FOR JVS FRI	
3	839-1148	4A DC SSR BD NH4P	
4	839-1011	SSR 1EA BD	
101	280-5009-01	CORD CLAMP 21	
102	280-0419	HARNESS LUG	
103	601-7467	L-LOCK BK	
104	400-5368-15024	SW REGU LCA150S-24	
105	601-0460	PLASTIC TIE BELT 100 MM	
106	270-5052-04	L-FILTER D	
201	011-P00325	TAP SCR PH 3 X 25	
202	011-F00310	TAP SCR FH 3 X 10	
203	011-T03512	TAP SCR TH 3.5 X 12	
204	011-T03516	TAP SCR TH 3.5 X 16	
205	000-P00308-W	M SCR PH W/FS M3 X 8	
301	FRI-60023	WIRE HARN I/O AC IN	
302	FRI-60025X	WIRE HARN I/O	
303	FRI-60026	WIRE HARN I/O DC IN	
304	FRI-60027	WIRE HARN I/O ANALOG	

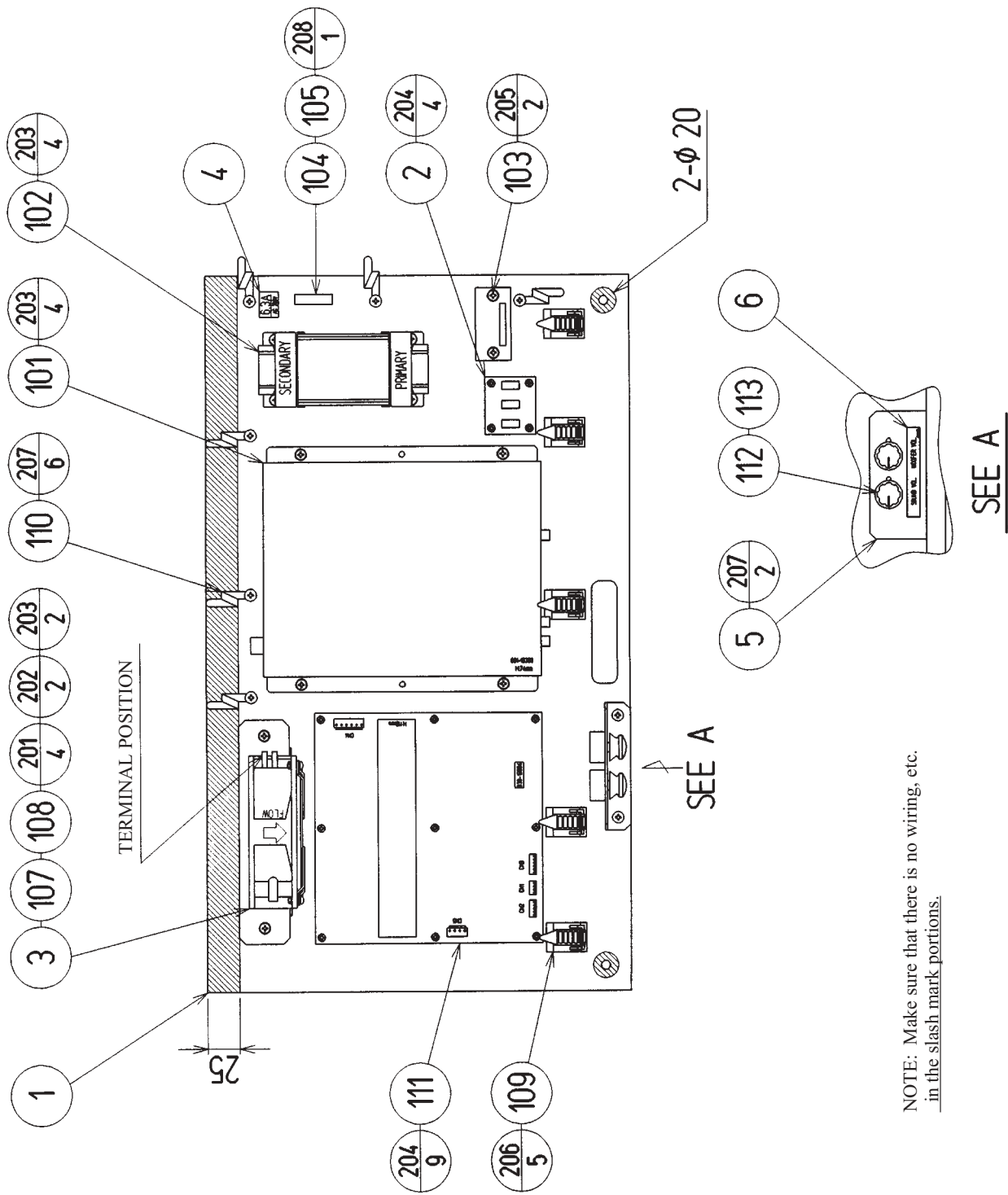

NOTE: Make sure that there is no wiring, etc. in the slash mark portions.

SEE A

④1 ASSY AUDIO BASE DX (FRI-4300)

( D-2/2 )

ITEM NO.	PART NO.	DESCRIPTION	NOTE
1	FRI-4301	WOODEN AUDIO BASE	
2	839-1147	AUDIO MIX BD UL	
3	DRT-4502	FAN MOTOR BRKT	
4	421-7914-250630	STICKER AC 250V 6.3A	
5	FRI-4302	VR BRKT	
6	421-11128	STICKER AMP VOL	
101	601-10369	STEREO PWR AMP 47	
102	560-5406-V	XFMR 100V 23V5A X 2	
103	117-5225	TERMINAL 3P 20A	
104	514-5086-6300	FUSE S.B 6300MA 250V HBC CE	
105	514-5084	FUSE HOLDER F-60B W/F-60	
106	310-5029-F20	SUMI TUBE FF 20MM	
107	260-0011-02	AXIAL FLOW FAN AC100V 50-60HZ	
108	601-8543	FAN GUARD	
109	280-5009-01	CORD CLAMP 21	
110	280-0419	HARNESS LUG	
111	838-13604	BASS AMP 50W X 1	
112	220-5179	VOL CONT B-5K OHM	
113	601-0042	KNOB 22 MM	
114	310-5029-D20	SUMITUBE F D 20 MM	
201	000-P00312-W	M SCR PH W/FS M3 X 12	
202	050-F00300	FLG NUT M3	
203	000-P00412-W	M SCR PH W/FS M4 X 12	
204	011-P00325	TAP SCR PH 3 X 25	
205	011-T03516	TAP SCR TH 3.5 X 16	
206	011-F00310	TAP SCR FH 3 X 10	
207	011-T03512	TAP SCR TH 3.5 X 12	
208	011-F00312	TAP SCR #1 FH 3 X 12	
301	FRI-60028	WIRE HARN AMP AC IN	
302	FRI-60029	WIRE HARN AMP FAN	
303	FRI-60030	WIRE HARN AMP XFMR IN	
304	FRI-60031	WIRE HARN 47 AMP AC IN	
305	FRI-60032	WIRE HARN BASS AMP AC IN	
306	FRI-60033	WIRE HARN SOUND MIX IN	
307	FRI-60034	WIRE HARN SOUND MIX OUT	
308	FRI-60035	WIRE HARN SOUND OUT	
309	FRI-60036	WIRE HARN AMP VOL IN	
310	FRI-60037	WIRE HARN BASS SP OUT	
311	FRI-60038	WIRE HARN SEAT SP OUT	
312	FRI-60091	WIRE HARN BASS VOL	

④2 ASSY SERVO DRV BASE DX (FRI-4400)

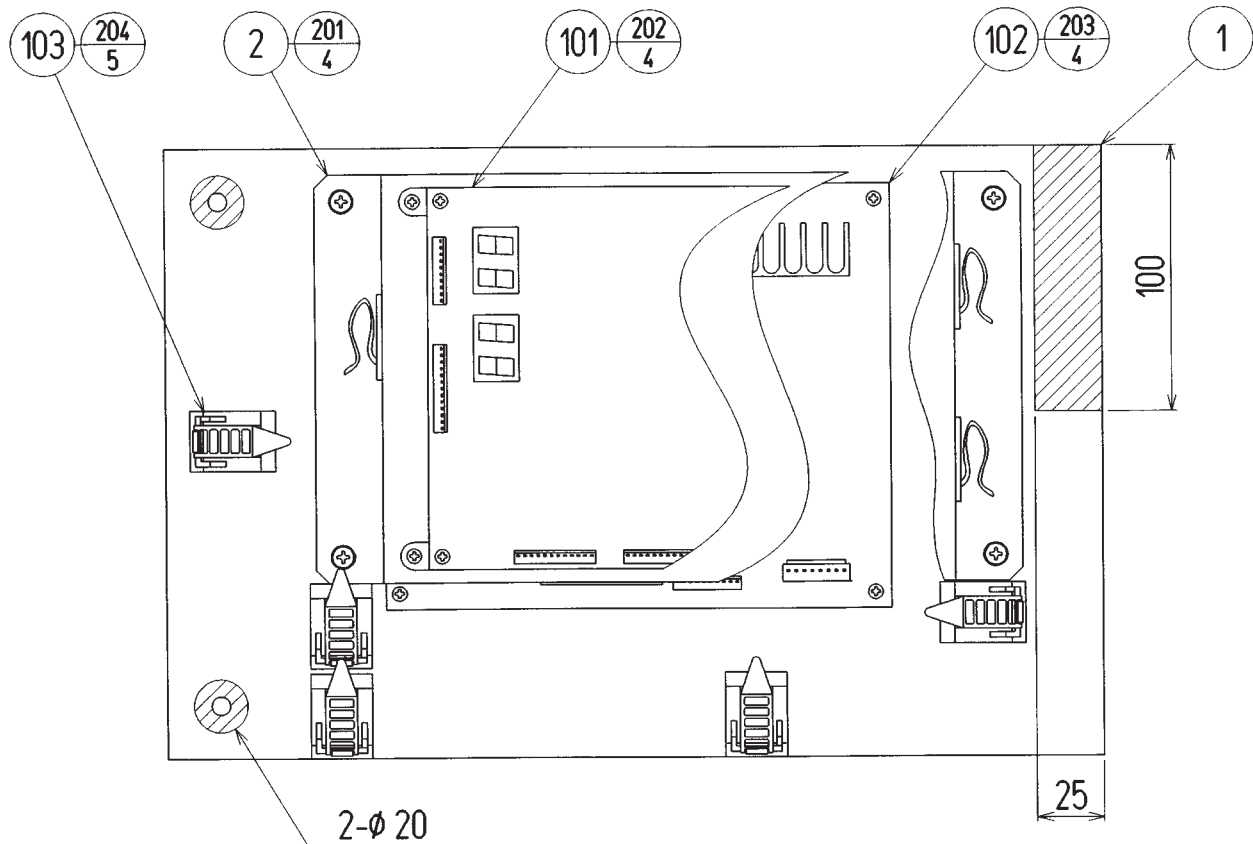

ITEM NO.	PART NO.	DESCRIPTION	NOTE
1	FRI-4401	WOODEN BASE SERVO	
2	FRI-4402	SERVO DRV BRKT	
101	838-13843	DRIVE BD FRI	
102	838-12912-01	SERVO MOTOR DRIVE BD NEW	
103	280-5009-01	CORD CLAMP 21	
104	601-0460	PLASTIC TIE BELT 100 MM	
201	000-P00412-W	M SCR PH W/FS M4 X 12	
202	000-P00312-W	M SCR PH W/FS M3 X 12	
203	011-P00325	TAP SCR PH 3 X 25	
204	011-F00310	TAP SCR FH 3 X 10	
301	FRI-60039	WIRE HARN SERVO AC IN	
302	FRI-60040	WIRE HARN DRV DC IN	
303	FRI-60041	WIRE HARN DRV CTRL	
304	FRI-60042	WIRE HARN SERVO CTRL	
305	FRI-60043	WIRE HARN SERVO ENC	
306	FRI-60044	WIRE HARN SERVO PWR	



# 21. WIRE COLOR CODE TABLE

THE WIRE COLOR CODE is as follow:

- A PINK
- B SKY BLUE
- C BROWN
- D PURPLE
- E LIGHT GREEN

Wires other than those of any of the above 5 single colors will be displayed by 2 alphanumeric characters.

- 1 RED
- 2 BLUE
- 3 YELLOW
- 4 GREEN
- 5 WHITE
- 7 ORANGE
- 8 BLACK
- 9 GRAY

If the right-hand side numeral of the code is 0, then the wire will be of a single color shown by the left-hand side numeral (see the above).

Note 1: If the right-hand side alphanumeric is not 0, that particular wire has a spiral color code. The left-hand side character shows the base color and the right-hand side one, the spiral color.

<Example> 51 ..... WHITE / RED

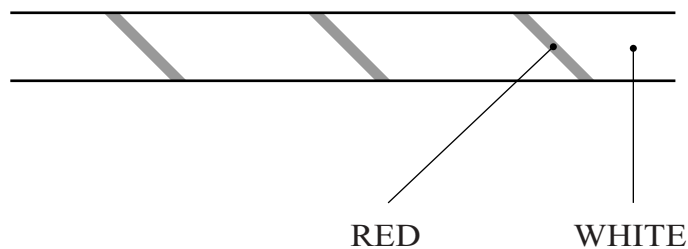

Note 2: The character following the wire color code indicates the size of the wire.

- U: AWG16, UL1015
- K: AWG18, UL1015
- L: AWG20, UL1007
- None: AWG22, UL1007

## **Warranty**

Your new Sega Product is covered for a period of 90 days from the date of shipment. This certifies that the Printed Circuit Boards, Power Supplies and Monitor are to be free of defects in workmanship or materials under normal operating conditions. This also certifies that all Interactive Control Assemblies are to be free from defects in workmanship and materials under normal operating conditions. No other product in this machine is hereby covered.

Sellers sole liability in the event a warranted part described above fails shall be, at its option, to replace or repair the defective part during the warranty period. For Warranty claims, contact your Sega Distributor.

Should the Seller determine, by inspection that the product was caused by Accident, Misuse, Neglect, Alteration, Improper Repair, Installation or Testing, the warranty offered will be null and void.

Under no circumstances is the Seller responsible for any loss of profits, loss of use, or other damages.

This shall be the exclusive written Warranty of the original purchaser expressed in lieu of all other warranties expressed or implied. Under no circumstance shall it extend beyond the period of time listed above.



**SEGA ENTERPRISES, INC. (USA)**

45133 Industrial Drive  
Fremont, CA 94538  
**(415) 701-6580** phone  
**(415) 701-6594** fax