

This document has been downloaded from:



The largest resource for amusement machines  
documentation on the world wide web!



**FLIPPERSPILL.COM**

1ST PRINTING FEB. 01

# SEGA

## *F355 challenge*

TWIN TYPE

### OWNER'S MANUAL



SEGA ENTERPRISES, INC. USA

MANUAL NO. 420-6507-05

# VISIT OUR WEBSITE!

The screenshot shows a Netscape browser window displaying the SegaService.com website. The browser's address bar shows the URL <http://www.segasevice.com/>. The website's navigation menu on the left includes links for 'what's new', 'manuals', 'bulletins', 'assemblies', 'Search', 'bulletin Sign-up', 'register name', 'staff', 'Darl's Office', 'tech. service', 'warranty policy', 'corporate info', 'home page', 'future technologies', 'plugins', and 'non-framed page'. Contact information for Sega Enterprises Inc., USA is provided: Service Department, phone 415.701.6580, fax 415.701.6594. The main content area features a 'Ask Dave!' section with a portrait of a man, a large 'SEGA SERVICE' logo, and a list of site features: Bulletins, Darl's Office, Game Manuals, Search, and What's New. A visitor counter indicates that 5564 people have visited the page since 3/16/01. A message encourages visitors to contact the site via email at [Darl.Davidson@seu.sega.com](mailto:Darl.Davidson@seu.sega.com). A banner at the bottom states 'THIS WEB SITE POWERED BY WebSTAR 4.3 Mac OS'. A list of links is provided: [\[what's new\]](#), [\[manuals\]](#), [\[bulletins\]](#), [\[assemblies\]](#), [\[Search\]](#), [\[staff\]](#), [\[Darl's office\]](#), [\[technical service\]](#), [\[customer service\]](#), [\[corporate info\]](#), [\[plugins\]](#), [\[Non-framed page\]](#). A note states 'You will need the following items to view this page in its entirety.' and lists software requirements: 'All Platforms' (with 'Get Acrobat Reader' icon), 'Windows' (with 'GET Microsoft Internet Explorer' icon), and 'Macintosh' (with 'GET Microsoft Internet Explorer' icon). The browser's status bar at the bottom indicates 'Internet zone'.

## **BEFORE USING THE PRODUCT, BE SURE TO READ THE FOLLOWING:**

### **To maintain the safety:**

To ensure the safe usage of the product, be sure to read the following before using the product. The following instructions are intended for the users, operators and the personnel in charge of the operation of the product. After carefully reading and sufficiently understanding the warning displays and cautions, handle the product appropriately. Be sure to keep this manual nearby the product or elsewhere convenient for referring to it when necessary.

Herein, explanations which require special attention are enclosed with dual lines. Depending on the potentially hazardous degrees, the terms of WARNING, CAUTION, etc. are used. Be sure to understand the contents of the displays before reading the text.



**WARNING!**

Indicates that mishandling the product by disregarding this warning will cause a potentially hazardous situation which can result in death or serious injury.



**CAUTION!**

Indicates that mishandling the product by disregarding this caution will cause a slight hazardous situation which can result in personal injury and or material damage.

### **For the safe usage of the product, the following pictographs are used:**



Indicates “HANDLE WITH CARE.” In order to protect the human body and equipment, this display is attached to places where the Owner’s Manual and or Service Manual should be referred to.

#### **○ Perform work in accordance with the instructions herein stated.**

Instructions for work are explained by paying attention to the aspect of accident prevention. Failing to perform work as per the instructions can cause accidents. In the case where only those who have technical expertise should perform the work to avoid hazardous situation, the instructions herein state that the serviceman should perform such work.

#### **○ Be sure to turn off power before working on the machine.**

To prevent electric shock, be sure to turn off power before starting the work in which the worker touches the interior of the product. If the work is to be performed in the power-on status, the Instruction Manual herein always states to that effect.

#### **○ Be sure to ground the Earth Terminal (this, however, is not required in the case where a power cord with earth is used).**

This product is equipped with the Earth Terminal. When installing the product, Connect the Earth Terminal to the “accurately grounded indoor earth terminal” by using an earth wire. Unless the product is grounded appropriately, the user can be subject to electric shock. After performing repair, etc. for the Control equipment, ensure that the Earth Wire is firmly connected to the Control equipment.

#### **○ Ensure that the Power Supply used is equipped with an Earth Leakage Breaker.**

This product does not incorporate the Earth Leakage Breaker. Using a power supply which is not equipped with the Earth Leakage Breaker can cause a fire when earth leakage occurs.

#### **○ Be sure to use fuses which meet the specified rating. (only for the machines which use fuses).**

Using fuses exceeding the specified rating can cause a fire and electric shock.

○ **Specification changes (removal of equipment, conversion and addition) not designated by SEGA are not allowed.**

The parts of the product include warning labels for safety, covers for personal protection, etc. It is very hazardous to operate the product by removing parts and or modifying the circuits. Should doors, lids and protective parts be damaged or lost, refrain from operating the product, and contact where the product was purchased from or the office herein stated. SEGA shall not be held responsible for any accidents, compensation for damage to a third party, resulting from the specifications not designated by SEGA.

○ **Ensure that the product meets the requirements of appropriate Electrical Specifications.**

Before installing the product, check for Electrical Specifications. SEGA products have a nameplate on which Electrical Specifications are described. Ensure that the product is compatible with the power supply voltage and frequency requirements of the location. Using any Electrical Specifications different from the designated Specifications can cause a fire and electric shock.

○ **Install and operate the product in places where appropriate lighting is available, allowing warning labels to be clearly read.**

To ensure safety for the customers, labels and printed instructions describing potentially hazardous situation are applied to places where accidents can be caused. Ensure that where the product is operated has sufficient lighting allowing the warnings to be read. If any label is peeled off, apply it again immediately. Please place an order with where the product was purchased from or the office herein stated.

○ **When handling the Monitor, be very careful. (Applies only to the product w/monitor.)**

Some of the monitor (TV) parts are subject to high tension voltage. Even after running off power, some portions are still subject to high tension voltage sometimes. Monitor repair and replacement should be performed only by those technical personnel who have knowledge of electricity and technical expertise.

○ **Be sure to adjust the monitor (projector) properly. (Applies only to the product w/monitor.)**

Do not operate the product leaving on-screen flickering or blurring as it is. Using the product with the monitor not properly adjusted may cause dizziness or a headache to an operator, a player, or the customers.

○ **When transporting or reselling this product, be sure to attach this manual to the product.**

In the case where commercially available monitors and printers are used in this product, only the contents relating to this product are explained herein. Some commercially available equipment has functions and reactions not stated in this manual. Read this manual together with the specific Instruction Manual of such equipment.

- Descriptions herein contained may be subject to improvement changes without notice.
- The contents described herein are fully prepared with due care. However, should any question arise or errors be found, please contact SEGA.

**INSPECTIONS IMMEDIATELY AFTER TRANSPORTING THE PRODUCT TO THE LOCATION.**

Normally, at the time of shipment, SEGA products are in a status allowing for usage immediately after transporting to the location. Nevertheless, an irregular situation may occur during transportation. Before turning on power, check the following points to ensure that the product has been transported in a satisfactory status.

- Are there any dented portions or defects (cuts, etc.) on the external surfaces of the cabinet?
- Are Casters and Adjusters, damaged?
- Do the power supply voltage and frequency requirements meet with those of the location?
- Are all wiring connectors correctly and securely connected? Unless connected in the correct direction, connector connections can not be made accurately. Do not insert connectors forcibly.
- Do power cords have cuts and dents?
- Do the fuses used meet specified rating? Is the Circuit Protector in an energized status?
- Are all accessories available?
- Can all Doors and Lids be opened with the Accessory keys? Can Doors and Lids be firmly closed?



---

---

## TABLE OF CONTENTS

---

---

BEFORE USING THE PRODUCT, BE SURE TO READ THE FOLLOWING:

### TABLE OF CONTENTS

#### INTRODUCTION OF THE OWNER'S MANUAL

1. HANDLING PRECAUTIONS .....	1 - 2
2. PRECAUTIONS CONCERNING INSTALLATION LOCATION .....	3 - 4
3. OPERATION .....	5 - 6
4. NAME OF PARTS .....	7
5. ACCESSORIES .....	8 - 10
6. ASSEMBLING AND PRECAUTIONS.....	11 - 23
7. PRECAUTIONS TO BE HEDED WHEN MOVING THE MACHINE .....	24 - 25
8. CONTENTS OF GAME.....	26 - 32
9. EXPLANATION OF TEST AND DATA DISPLAY.....	33 - 54
9 - 1 SWITCH UNIT AND COIN METER.....	34
9 - 2 SYSTEM TEST MODE.....	35 - 47
9 - 3 GAME TEST MODE.....	48 - 54
10. CONTROL PANEL.....	55 - 57
10- 1 REMOVING THE CONTROL PANEL.....	55
10- 2 ADJUSTING AND REPLACING THE HANDLE'S (STEERING WHEEL'S) V.R. ....	56
10- 3 GREASING.....	57
11. ACCELERATOR & BRAKE.....	58 - 59
11- 1 ADJUSTING AND REPLACING THE V.R. ....	58 - 59
11- 2 GREASING.....	59
12. PADDLE (WING) SHIFT.....	60 - 61
13. COIN SELECTOR.....	62 - 65
14. MONITOR.....	66 - 70
14- 1 CAUTIONS AND WARNINGS CONCERNING THE SAFETY FOR HANDLING THE MONITORS.....	66 - 67
14- 2 CAUTIONS TO BE HEDED WHEN CLEANING THE CRT SURFACES....	68
14- 3 ADJUSTMENT METHOD.....	69 - 70
15. REPLACING THE FLOURESCENT LAMP.....	71 - 72
16. PERIODIC INSPECTION TABLE.....	73 - 74
17. TROUBLESHOOTING.....	75 - 77
18. GAME BOARD.....	78 - 82
18- 1 REMOVING THE BOARD.....	78 - 79
18- 2 FILTER BOARD.....	80
18- 3 ERROR DISPLAY (DRIVE CONTROL BOARD).....	81 - 82
19. DESIGN RELATED PARTS.....	83 - 84
20. COMMUNICATION PLAY.....	85 - 88
20 - 1 INSTALLATION PRECAUTIONS.....	85
20 - 2 CONNECTING THE COMMUNICATION CABLES.....	85 - 88
20 - 3 SETTING FOR COMMUNICATION PLAY.....	89
20 - 4 CAUTIONS TO BE HEDED WHEN USING THE TEST MODE.....	89
21. PARTS LIST.....	90 - 134
22. WIRE COLOR CODE TABE.....	135
23. WIRING DIAGRAM.....	136 - 140

---

---

## SPECIFICATIONS

Installation Space	: 1,632 mm (W) X 1,700 mm (D) (64.3 in. X 66.9 in.)
Height	: 1,864 mm (73.3 in.)
Weight	: Approx 507 kg. ( 1,117.7 lbs.)
Power, maximum current	: 555 W 6.50 A (AC 110V 50 Hz AREA) 558 W 6.50 A (AC 110V 60 Hz AREA) 536 W 5.70 A (AC 120V 60 Hz AREA) 558 W 3.30 A (AC 220V 50 Hz AREA) 547 W 3.20 A (AC 220V 60 Hz AREA) 568 W 3.30 A (AC 230V 50 Hz AREA) 544 W 3.10 A (AC 230V 60 Hz AREA) 563 W 3.10 A (AC 240V 50 Hz AREA) 533 W 2.90 A (AC 240V 60 Hz AREA)
For TAIWAN	
Power, current	: 575 W 7.00 A (MAX.) 440 W 5.30 A (MIN.)
MONITOR	: 29 TYPE COLOR MONITOR

## INTRODUCTION OF THE OWNERS MANUAL

This Owner's Manual is intended to provide detailed descriptions together with all the necessary information covering the general operation of electronic assemblies, electromechanicals, servicing control, spare parts, etc. as regards the product, **F355 challenge TWIN TYPE.**

This manual is intended for the owners, personnel and managers in charge of operation of the product. Operate the product after carefully reading and sufficiently understanding the instructions. If the product fails to function satisfactorily, non-technical personnel should under no circumstances touch the internal system. Please contact where the product was purchased from.

Use of this product is unlikely to cause physical injuries or damages to property. However, where special attention is required this is indicated by a thick line, the word "IMPORTANT" and its sign in this manual.



**IMPORTANT**

Indicates that mishandling the product by disregarding this display can cause the product's intrinsic performance not to be obtained, resulting in malfunctioning.

SEGA ENTERPRISES, INC. (U.S.A.)/CUSTOMER SERVICE  
45133 Industrial Drive, Fremont, California 94538, U.S.A.  
Phone : (415) 701-6580  
Fax : (415) 701-6594

## DEFINITION OF LOCATION MAINTENANCE MAN AND SERVICEMAN



Non-technical personnel who do not have technical knowledge and expertise should refrain from performing such work that this manual requires the location's maintenance man or a serviceman to carry out, or work which is not explained in this manual. Failing to comply with this instruction can cause a severe accident such as electric shock.

Ensure that parts replacement, servicing & inspections, and troubleshooting are performed by the location's maintenance man or the serviceman. It is instructed herein that particularly hazardous work should be performed by the serviceman who has technical expertise and knowledge.

The location's maintenance man and serviceman are herein defined as follows:

### **"Location's Maintenance Man" :**

Those who have experience in the maintenance of amusement equipment and vending machines, etc., and also participate in the servicing and control of the equipment through such routine work as equipment assembly and installation, servicing and inspections, replacement of units and consumables, etc. within the Amusement Facilities and or locations under the management of the Owner and Owner's Operators of the product.

### **Activities of Location's Maintenance Man :**

Assembly & installation, servicing & inspections, and replacement of units & consumables as regards amusement equipment, vending machines, etc.

### **Serviceman :**

Those who participate in the designing, manufacturing, inspections and maintenance service of the equipment at an amusement equipment manufacturer.

Those who have technical expertise equivalent to that of technical high school graduates as regards electricity, electronics and or mechanical engineering, and daily take part in the servicing & control and repair of amusement equipment.

### **Serviceman's Activities :**

Assembly & installation and repair & adjustments of electrical, electronic and mechanical parts of amusement equipment and vending machines.

**LISTED**



**5K92**

**AMUSEMENT MACHINE**



# 1. HANDLING PRECAUTIONS

When installing or inspecting the machine, be very careful of the following points and pay attention to ensure that the player can enjoy the game safely.

Non-compliance with the following points or inappropriate handling running counter to the cautionary matters herein stated can cause personal injury or damage to the machine.



**WARNING!**

- Before performing work, be sure to turn power off. Performing the work without turning power off can cause an electric shock or short circuit. In the case work should be performed in the status of power on, this manual always states to that effect.
- To avoid electric shock or short circuit, do not plug in or unplug quickly.
- To avoid electric shock, do not plug in or unplug with a wet hand.
- Do not expose Power Cords and Earth Wires on the surface, (floor, passage, etc.). If exposed, the Power Cords and Earth Wires are susceptible to damage. Damaged cords and wires can cause electric shock or short circuit.
- To avoid causing a fire or electric shock, do not put things on or damage Power Cords.
- When or after installing the product, do not unnecessarily pull the power cord. If damaged, the power cord can cause a fire or electric shock.
- In case the power cord is damaged, ask for replacement through where the product was purchased from or the office herein stated. Using the cord as is damaged can cause fire, electric shock or leakage.
- Be sure to perform grounding appropriately. Inappropriate grounding can cause an electric shock.
- Be sure to use fuses meeting specified rating. Using fuses exceeding the specified rating can cause a fire or electric shock.
- Completely make connector connections for IC BD and others. Insufficient insertion can cause an electric shock.
- To avoid causing a fire or electric shock, do not make Specification changes by removing, converting and making additions unless otherwise designated by SEGA.
- Be sure to perform periodic maintenance inspections herein stated.



**IMPORTANT!**

- For the IC board circuit inspections, only the logic tester is allowed. The use of a multiple-purpose tester is not permitted, so be careful in this regard.
- When cleaning the CRT surfaces, use a soft, dry cloth. Do not apply chemicals such as thinner, benzine, etc.
- The electronic parts on the IC Board could be damaged due to human body's static electricity. Before performing IC Board related work, be sure to discharge physically accumulated statics by touching grounded metallic surfaces, etc.

## CONCERNING THE STICKER DISPLAY

SEGA product has Stickers describing the product manufacture No. (Serial No.) and Electrical Specifications. Also it has a Sticker describing where to contact for repair and for purchasing parts. When inquiring about or asking for repair, mention the Serial No. and Name of Machine indicated on the Sticker. The Serial No. indicates the product register. Identical machines could have different parts depending on the date of production. Also, improvements and modifications might have been made after the publication of this Manual. In order to meet the above situations, mention the Serial No. when contacting the applicable places.

## CONCERNING WARNING DISPLAYS

SEGA product has warning displays on Stickers, Labels and or printed instructions adhered / attached to or incorporated in the places where a potentially hazardous situation can arise. The warning displays are intended for accident prevention for the customers and for avoiding hazardous situation relating to maintenance and servicing work. There are some portions in the Cabinet, which are subject to high tension voltage, etc. where accidents can be caused merely by touching. When performing the servicing work, be very careful of the warning displays. Especially, any complex repair and replacement work not mentioned herein, should be performed by those technical personnel who have knowledge of electricity and technical expertise. For the prevention of accidents, caution any customer whose act runs counter to the warnings, as to the effect that he must stop the act.

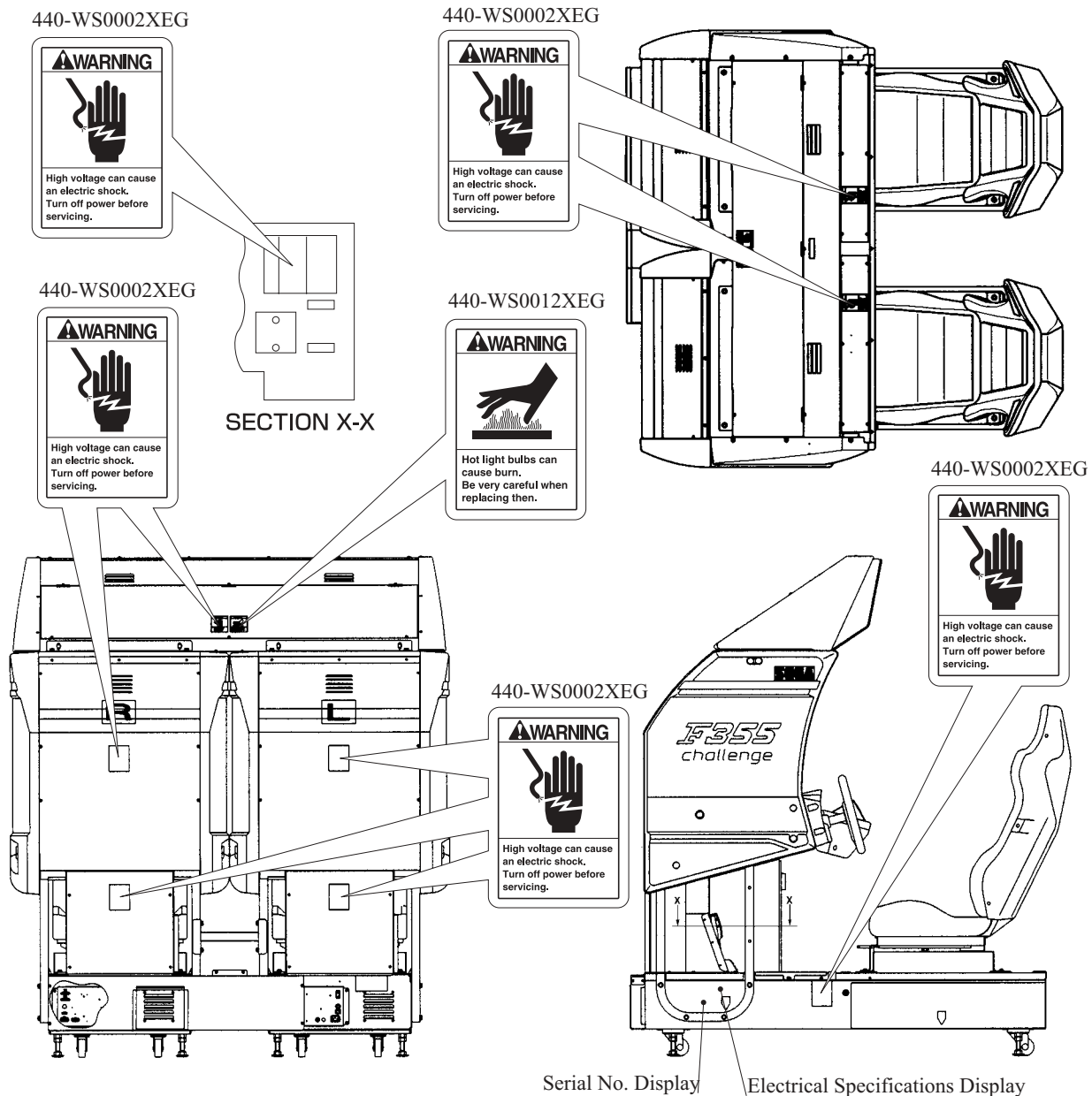

## 2. PRECAUTIONS CONCERNING INSTALLATION

### LOCATION



WARNING!

This product is an indoor game machine. Do not install it outside. Even indoors, avoid installing in places mentioned below so as not to cause a fire, electric shock, injury and or malfunctioning.

- Places subject to rain or water leakage, or places subject to high humidity in the proximity of an indoor swimming pool and or shower, etc.
- Places subject to direct sunlight, or places subject to high temperatures in the proximity of heating units, etc.
- Places filled with inflammable gas or vicinity of highly inflammable/volatile chemicals or hazardous matter.
- Dusty places.
- Sloped surfaces.
- Places subject to any type of violent impact.
- Vicinity of anti-disaster facilities such as fire exits and fire extinguishers.
- The operating (ambient) temperature range is from 5° C to 40° C.  
Only in the case a projector is employed, the temperature range is from 5° C to 30° C.

### LIMITATIONS OF USAGE REQUIREMENTS



WARNING!

- Be sure to check the Electrical Specifications.  
Ensure that this product is compatible with the location's power supply, voltage and frequency requirements.  
A plate describing Electrical Specifications is attached to the product.  
Non-compliance with the Electric Specifications can cause a fire and electric shock.
- This product requires the Breaker and Earth Mechanisms as part of the location facilities. Using them in a manner not independent can cause a fire and electric shock.
- Ensure that the indoor wiring for the power supply is rated at 10A or higher (AC single phase 100 ~ 120V area), and 5A or higher (AC 220 ~ 240V area).  
Non-compliance with the Electrical Specifications can cause a fire and electric shock.
- Be sure to independently use the power supply equipped with the Earth Leakage Breaker. Using a power supply without the Earth Leakage Breaker can cause an outbreak of fire when earth leakage occurs.
- Putting many loads on one electrical outlet can cause generation of heat and a fire resulting from overload.
- When using an extension cord, ensure that the cord is rated at 10A or higher (AC 100 ~ 120V area) and 5A or higher (AC 220 ~ 240V area). Using a cord rated lower than the specified rating can cause a fire and electric shock.



- For transporting the machine into the location's building, the minimum necessary dimensions of the opening (of doors, etc.) are 0.85m(W) and 1.55m(H).
- For the operation of this machine, secure a minimum area of 2.2m (W) x 2.3m (D). For ventilation, provide an approximately 20cm. space between the rear part of the cabinet and the wall.

Electric current consumption

- MAX. 6.50 A (AC 110V 50 Hz)
- MAX. 6.50 A (AC 110V 60 Hz)
- MAX. 5.70 A (AC 120V 60 Hz)
- MAX. 3.30 A (AC 220V 50 Hz)
- MAX. 3.20 A (AC 220V 60 Hz)
- MAX. 3.30 A (AC 230V 50 Hz)
- MAX. 3.10 A (AC 230V 60 Hz)
- MAX. 3.10 A (AC 240V 50 Hz)
- MAX. 2.90 A (AC 240V 60 Hz)
- MAX. 7.00 A (For TAIWAN)

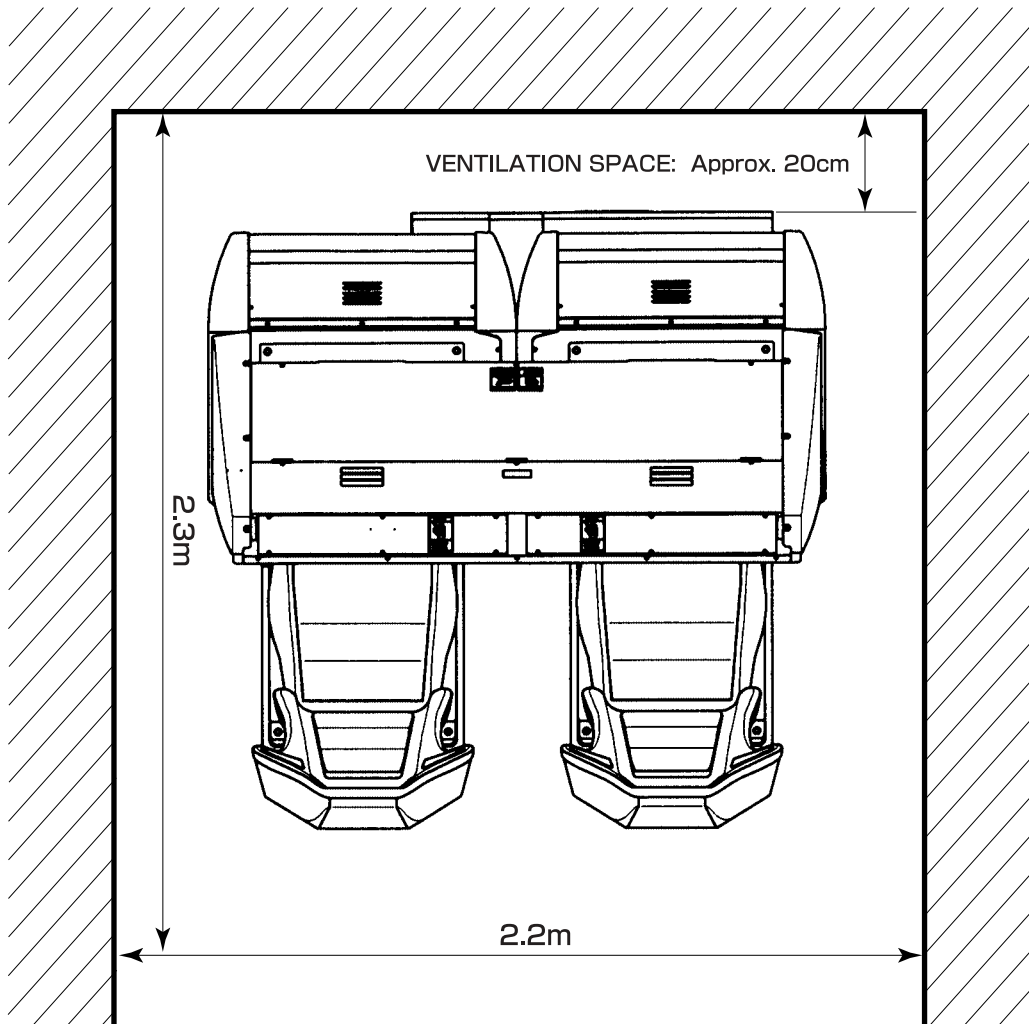

FIG. 2

### 3. OPERATION

#### PRECAUTIONS TO BE HEEDED BEFORE STARTING THE OPERATION

To avoid injury and trouble, be sure to constantly give careful attention to the behavior and manner of the visitors and players.



In order to avoid accidents, check the following before starting the operation:

- Check if all of the adjusters are in contact with the surface. If they are not, the Cabinet can move and cause an accident.

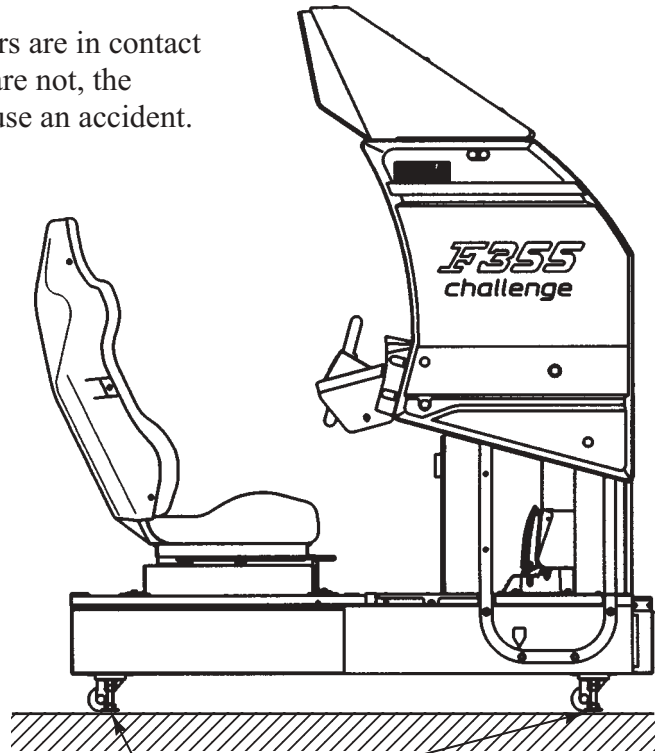

Ensure that all of the Adjusters are in contact with the floor.

- Do not put any heavy item on this product. Placing any heavy item on the product can cause a falling down accident or parts damage.
- Do not climb on the product. Climbing on the product can cause falling down accidents. To check the top portion of the product, use a step.
- To avoid electric shock, check to see if door & cover parts are damaged or omitted.
- To avoid electric shock, short circuit and or parts damage, do not put the following items on or in the periphery of the product.  
Flower vases, flowerpots, cups, water tanks, cosmetics, and receptacles/containers/vessels containing chemicals and water.



To avoid injury, be sure to provide sufficient space by considering the potentially crowded situation at the installation location. Insufficient installation space can cause the customers to come into contact with or hit the others and result in injury or trouble.

PRECAUTIONS TO BE HEEDED DURING OPERATION (PAYING ATTENTION TO CUSTOMERS)

To avoid injury and trouble, be sure to constantly give careful attention to the behavior and manner of the visitors and players.



- To avoid injury and accidents, those who fall under the following categories are not allowed to play the game.
  - Those who need assistance such as the use of an apparatus when walking.
  - Those who have high blood pressure or a heart problem.
  - Those who have experienced muscle convulsion or loss of consciousness when playing video game, etc.
  - Those who have a trouble in the neck and or spinal cord.
  - Intoxicated persons.
  - Pregnant women or those who are in the likelihood of pregnancy.
  - Persons susceptible to motion sickness.
  - Persons whose act runs counter to the product's warning displays.
- To avoid injury resulting from falling down, and electric shock due to spilled drinks, instruct the player not to place heavy items or drinks on the product.
- To avoid electric shock and short circuit, do not allow customers to put hands and fingers or extraneous matter in the openings of the product or small openings in or around the doors.
- To avoid falling down and injury resulting from falling down, immediately stop the customer's leaning against or climbing on the product, etc.
- To avoid electric shock and short circuit, do not allow the customers to unplug the power plug without a justifiable reason.



- Immediately stop such violent acts as hitting and kicking the product. Such violent acts can cause parts damage or falling down, resulting in injury due to fragments and falling down.
- Instruct the Player to take firm hold of the Steering Wheel when in play. The Steering Wheel is equipped with reaction mechanism. Holding the Steering Wheel lightly while playing the game can cause a contingent accident.
- Instruct the customer, other than the Player, not to touch the operation device when in play. Touching the operation device during play can cause accidents and trouble between customers.
- This product has a difference in grade. To avoid falling down accident, instruct the player to watch his/her step when getting on/off the Floor Base.
- Instruct the Player to adjust the seat before playing the game. Playing the game in a forcible posture can cause a contingent accident.
- This product is designed for players taller than 130cm and shorter than 210cm. To avoid accidents, instruct the customers who do not meet the height requirements to refrain from playing the game.



# 4. NAME OF PARTS

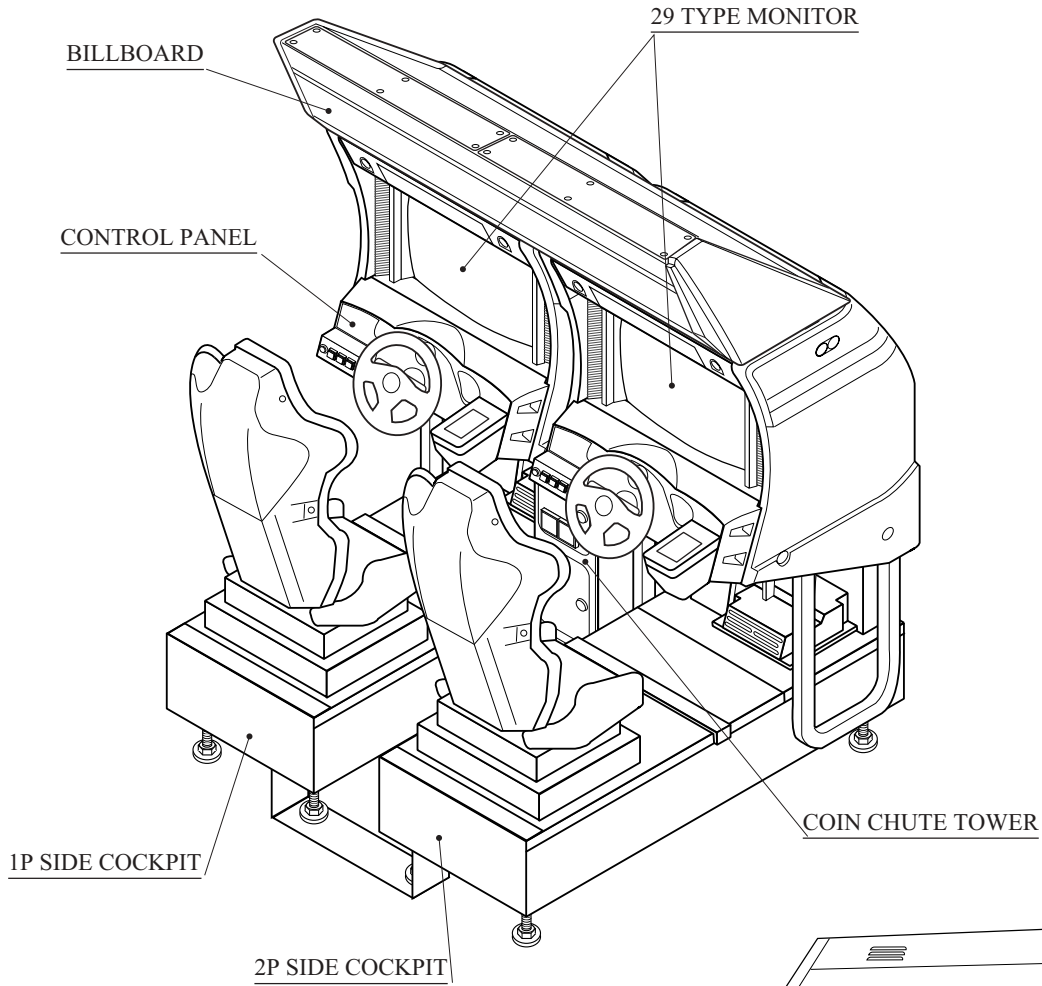

FIG. 4 a OVERVIEW

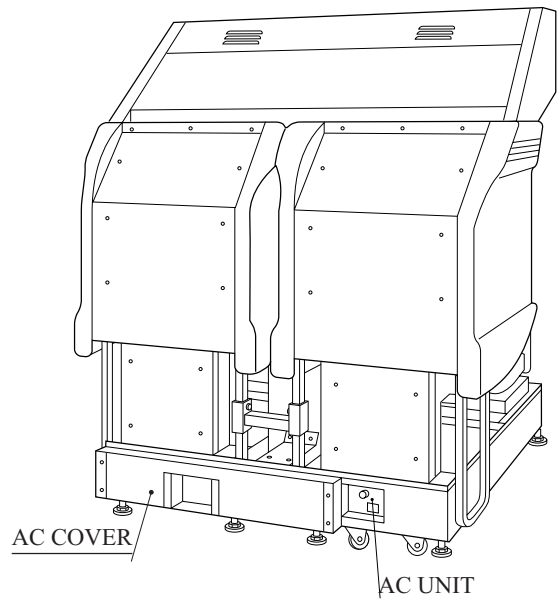

FIG. 4 b REAR VIEW

TABLE 4

	Width	X	Length	X	Height	Weight
COCKPIT (per seat)	820 mm	X	1,645 mm	X	1,520 mm	228 kg
COIN CHUTE TOWER	305 mm	X	515 mm	X	570 mm	15 kg
BILLBOARD	1,609 mm	X	617 mm	X	354 mm	36 kg
When assembled	1,632 mm	X	1,700 mm	X	1,864 mm	Approx. 507 kg

# 5. ACCESSORIES

When transporting the machine, make sure that the following parts are supplied.

TABLE 5 ACCESSORIES

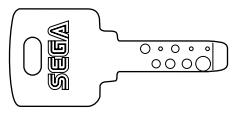
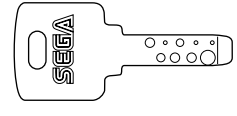
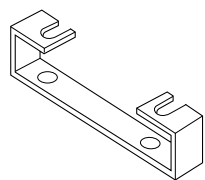
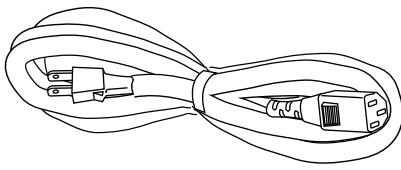
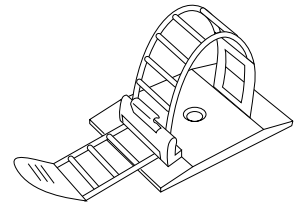
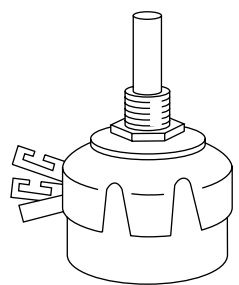
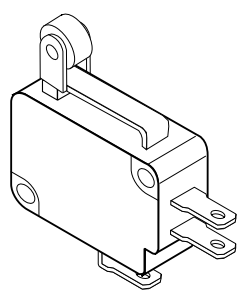
<p><b>DESCRIPTION</b></p> <p>Part No. (Qty.)</p> <p>Note</p> <p>Figures</p> <p>If Part No. has no description, the Number has not been registered or can not be registered. Such a part may not be obtainable even if the customer desires to purchase it. Therefore, ensure that the part is in safekeeping with you.</p>	<p><b>OWNERS MANUAL</b></p> <p>420-6507-05 (1)</p>	<p><b>KEY MASTER</b></p> <p>220-5576 (2)</p> <p>For opening/closing the doors</p>	<p><b>KEY</b></p> <p>(2)</p> <p>For the CASHBOX DOOR</p>
			
		<p>The Keys are inside the Coin Chute Door at the time of shipment from the factory.</p>	
<p><b>TAMPERPROOF†WRENCH</b></p> <p>M8 540-0009-01 (1)</p> <p>TOOL</p>			
		<p><b>JOINT PLATE</b></p> <p>DYN-0020 (1)</p> <p>Used for installation, see <b>2</b> of Section 6.</p>	
			
<p>AC Cable (Power Cord)</p> <p>600-6724 (1) AC 110V AREA</p> <p>600-6729 (1) AC 220 ~ 240V AREA</p> <p>600-6618 (1) AC 220 ~ 240V AREA</p> <p>Used for installation, see <b>5</b> of Section 6.</p>			
		<p><b>CORD CLAMP</b></p> <p>280-5009-01 (1)</p> <p>Used for securing the power cord. see <b>5</b> of Section 6.</p>	
			
<p><b>VOL CONT B-5K OHM</b></p> <p>220-5373 (1)</p> <p>220-5484 (1)</p> <p>Spare, see Section 10, 11.</p>			
		<p><b>SW MICRO TYPE</b></p> <p>509-5357 (1)</p> <p>For spare, refer to Section 12.</p>	
			

FUSE 7A  
514-5036-7000 (2)  
Spare, see Section 17.

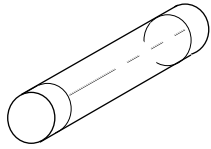

FLEX TUBE  
310-5050-220090 (1)  
For communication play, refer to Section 20.

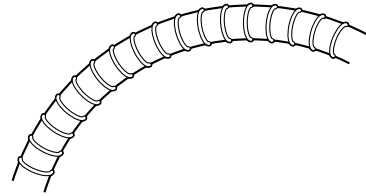

CONN 22  
310-5051-22 (2)  
For communication play, refer to Section 20.

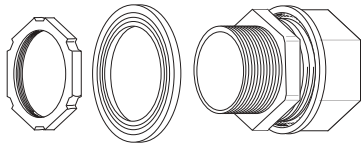

STICKER NO.OPTION  
421-11210 (1)  
For communication play, refer to Section 20.

CARTON BOX  
601-10835 (1)  
Used for transporting the Game Board.  
Refer to the following.

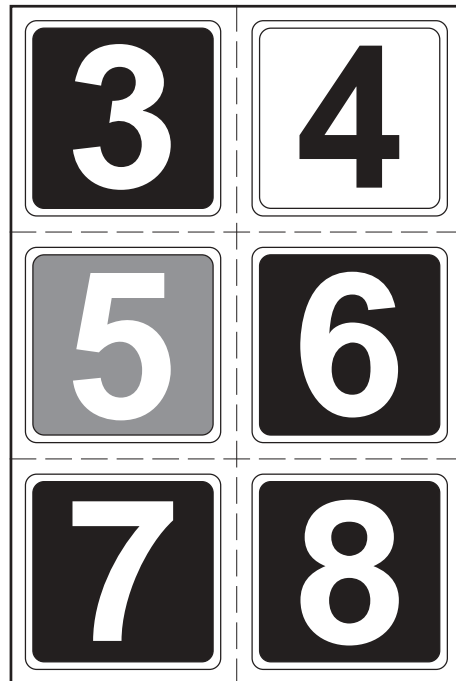
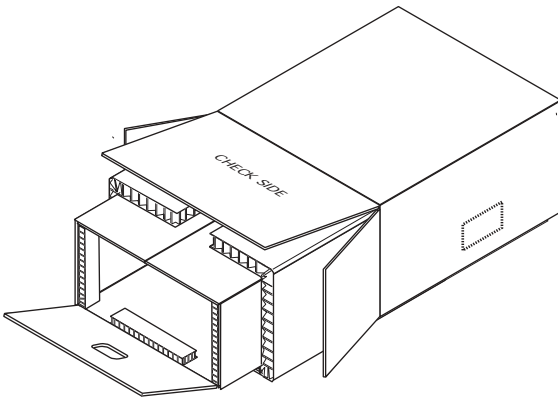

## HOW TO USE THE CARTON BOX



When requesting for the replacement/repair of this product's Game Board (NAOMI BOARD), follow the instructions below. Transporting the Game Board in an undesignated status is unacceptable. An erroneous handling can cause parts damage.

- Put the Game Board in the Carton Box together with the Shield Case. Do not unnecessarily disassemble nor remove parts.
- By paying careful attention to the following Figure and the direction shown by on-Carton-Box printing, put the Shield Case in the Carton Box.
- When putting the Shield Case in the Carton Box, do not remove Leg Brackets.
- The projected portions of the packing material is intended for cushioning. Therefore, do not bend the projected portions.

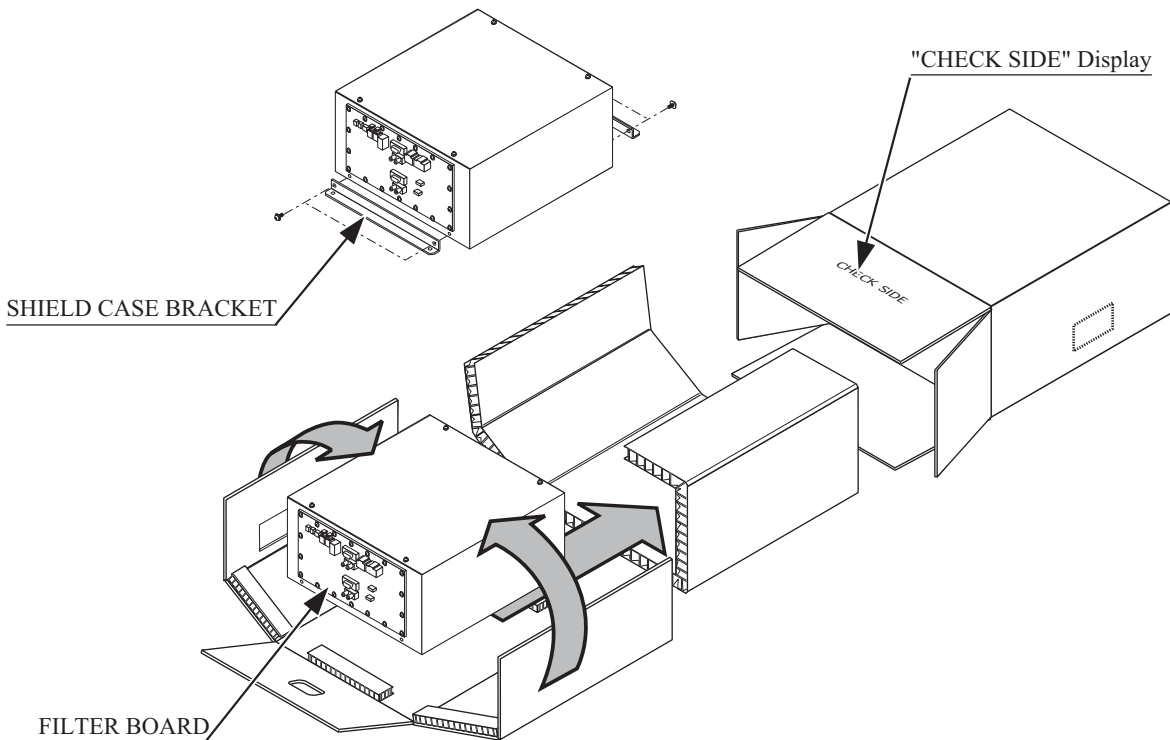

Fold the packing material shown in the Figure, enfold the Shield Case and put it in the Carton Box. Positioning the Shield Case upside down or packing in the manner different from what is shown in this Figure can cause the Game Board and other parts to be damaged.

## 6. ASSEMBLING AND PRECAUTIONS



- Perform assembly work by following the procedure herein stated. Failing to comply with the instructions can cause electric shock hazard.
- Assembling should be performed as per this manual. Since this is a complex machine, erroneous assembling can cause an electric shock, machine damage and or not functioning as per specified performance.
- Perform connector connection securely. Insufficient insertion can cause electric shock and short circuit hazards.
- This work should be performed by the Location's Maintenance Man or Serviceman. Working by those who do not have technical expertise can cause such severe accidents as electric shock. Failing to perform work in accordance with the explanations given in this manual can cause such severe accidents as electric shock to the player during operation.
- Be careful so as not to damage wiring. Damaged wiring can cause electric shock and short circuit hazards.

When carrying out the assembly work, follow the procedure in the following 7-item sequence:

- 1 ASSEMBLING THE COCKPIT
- 2 SECURING IN PLACE (ADJUSTER ADJUSTMENT)
- 3 INSTALLING THE BILLBOARD
- 4 INSTALLING THE AC COVERS (WIRING CONNECTION)
- 5 POWER SUPPLY, AND EARTH CONNECTION
- 6 TURNING POWER ON
- 7 ASSEMBLING CHECK

Note that the master key and the cashbox door key (accessories) in addition to the tools such as a Phillips type screwdriver, wrench for M16 hexagon bolt and socket wrench are required for the assembly work.

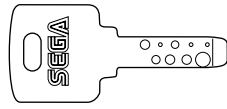

MASTER KEY

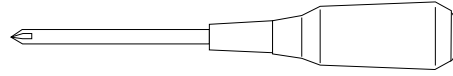

PHILLIPS TYPE SCREWDRIVER

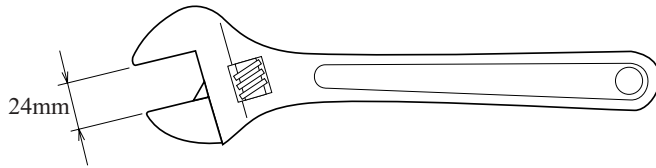

WRENCH (for M16 hexagon bolt)

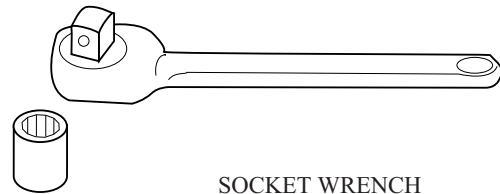

SOCKET WRENCH



CAUTION!

Perform the tightening of hexagon bolts described in **1** above after adjusting the adjusters as per **2**. Make sure that until the adjuster adjustments are made, keep the hexagon bolts tightened temporarily.



## ASSEMBLING THE COCKPIT

- 1 Place the two cockpits side by side. Position the 1P cabinet at the left-hand side as viewed facing the monitor. STICKER "L" is attached on the back of 1P cabinet, and STICKER "R" on the back of 2P cabinet.

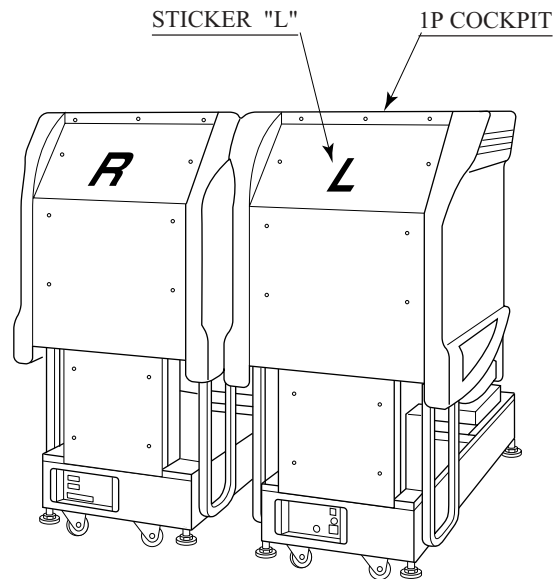

FIG. 6. 1 a



- ② Install the coin chute tower in between both cabinets. Open the coin chute door and the cashbox door to secure with the 4 hexagon bolts from inside the doors. At this time, make sure that the bolts are fastened temporarily.

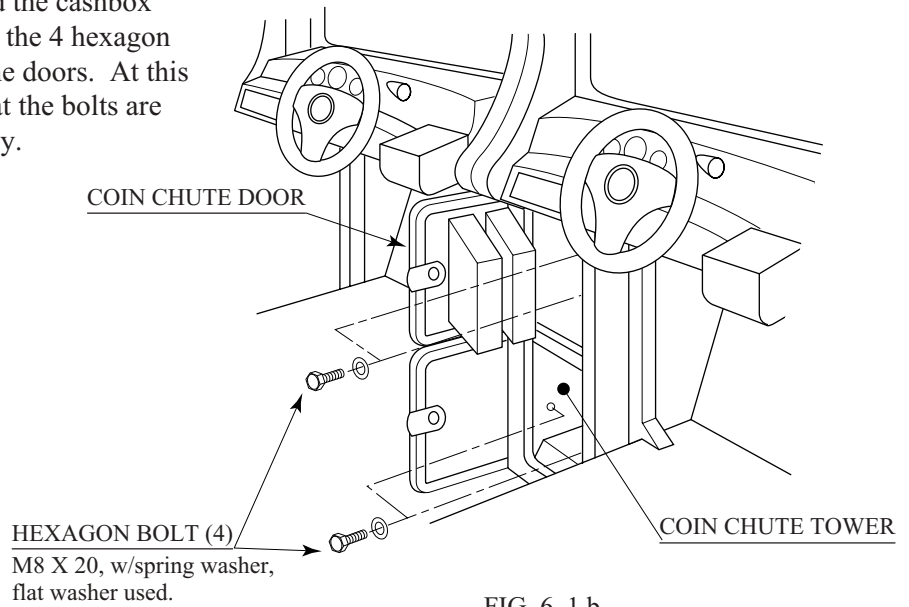

FIG. 6. 1 b

- ③ Install the joint pipe on to the backside of both cabinets by securing with 4 hexagon bolts (at this time, temporarily).

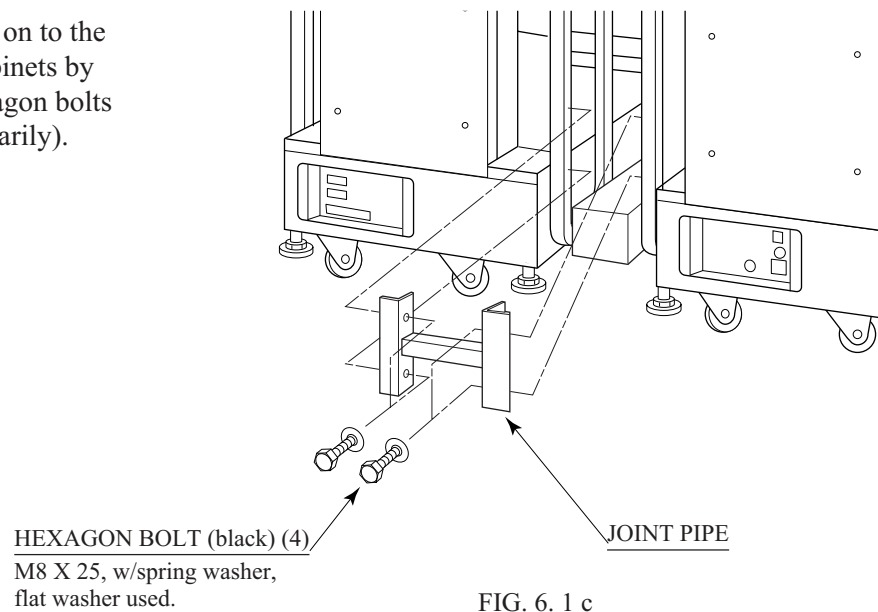

FIG. 6. 1 c

- ④ Attach the blind cap to the head of each hexagon bolt (6 bolts on each side of the monitor ... a total of 12) by pressing it in.

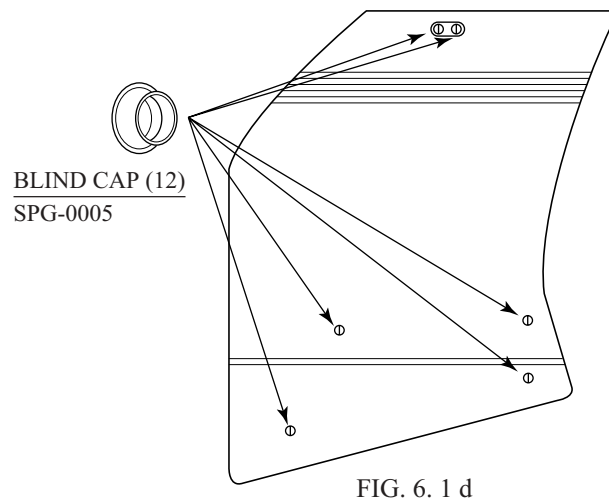

FIG. 6. 1 d

## 2

### SECURING IN PLACE (ADJUSTER ADJUSTMENT)



WARNING!

- Make sure that all of the adjusters are in contact with the floor. If they are not, the cabinet can move and cause an accident.
- Be sure to use plural workers to perform work. Depending on the specific work, there are some cases in which working by one person alone can cause personal injury and parts damage.

This machine has 8 casters and 8 adjusters (Fig. 6.2a). When the installation position is determined, cause the adjusters to come into contact with the floor directly, make adjustments in a manner so that the casters will be raised approximately 5mm. from the floor and make sure that the machine position is level.

- ① Move the machine to the installation position. When installing the machine against or close to a wall, be sure to secure a passage space to enable the player to take a ride in the machine.
- ② Attach the joint plate for the 2 internal adjusters shown. First, cause the other 6 adjusters to come into contact with the floor. Make adjuster adjustments with a wrench in a manner to ensure the machine's position is level (Fig.6.2b).
- ③ After making adjustments, fasten the adjuster nut upward and secure the height of the adjuster (Fig.6.2b).

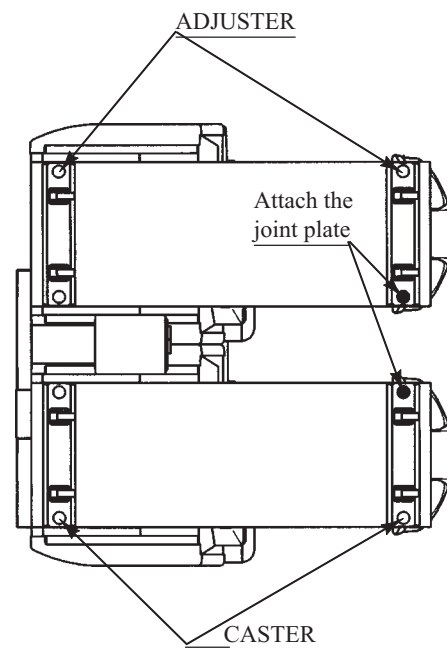

FIG. 6. 2 a BOTTOM VIEW

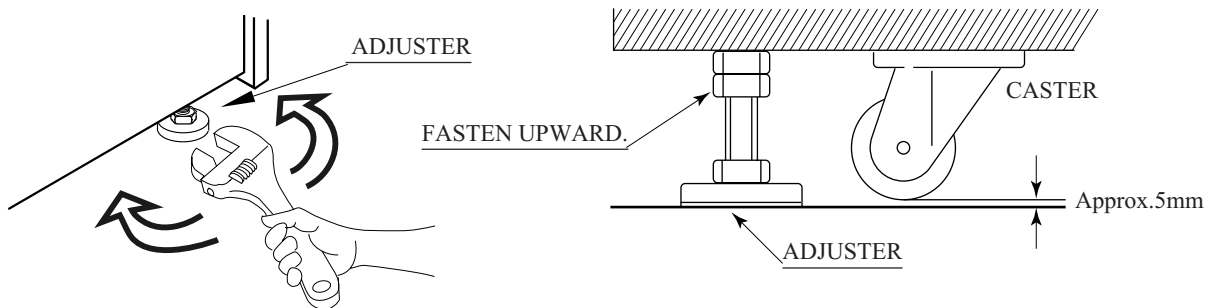

FIG. 6. 2 b ADJUSTER

- ④ Insert the notch portions of the joint plate to the 2 adjuster bolt portions.
- ⑤ Lower the adjuster and fasten the nut upward. Secure the joint plate with the nuts and the bottom of adjuster.

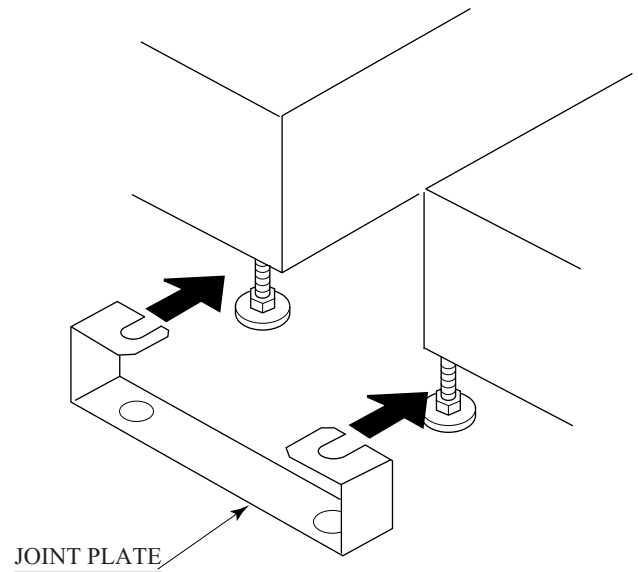
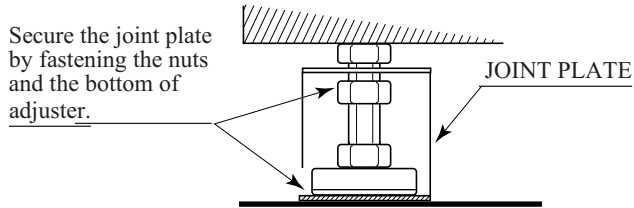

FIG. 6. 2 c JOINT PLATE

After securing the height of the adjusters, tighten all of the hexagon bolts which were fastened temporarily as per 1 above.

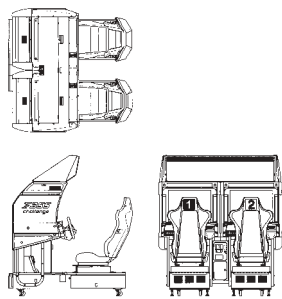

FIG. 6. 2 d  
Refer to this Fig. (Scale:1/100)  
for the layout of the place of  
installation.

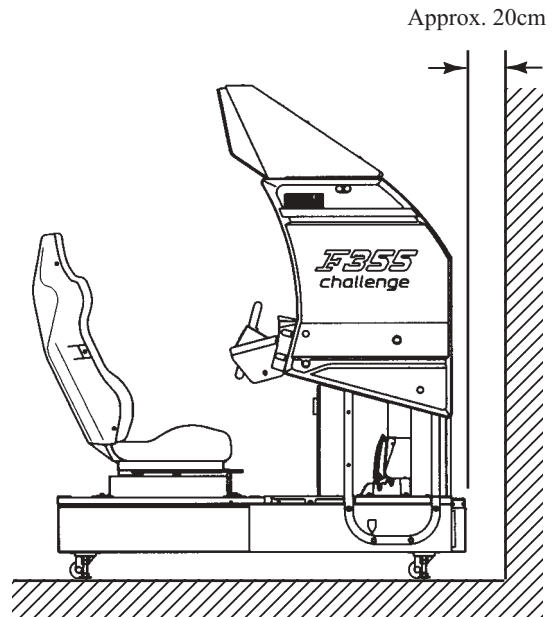

FIG. 6. 2 e  
Provide sufficient space so as to  
allow for ventilation by the  
ventilation fan.

# 3

## INSTALLING THE BILLBOARD



The Billboard is extremely heavy, weighing approximately 36kg. When installing it, be sure to use plural workers. Performing work by one person can cause an accident.



To perform work safely and securely, be sure to prepare a step which is in a secure and stable condition. Performing work without using the step can cause violent falling down accidents.

- 1 Mount the BILLBOARD over the cabinet. When performing work, be sure to use 3 or more workers.
- 2 Take out 3 Truss Screws to open the BILLBOARD LID.

TRUSS SCREW (3) black  
M4 X 8

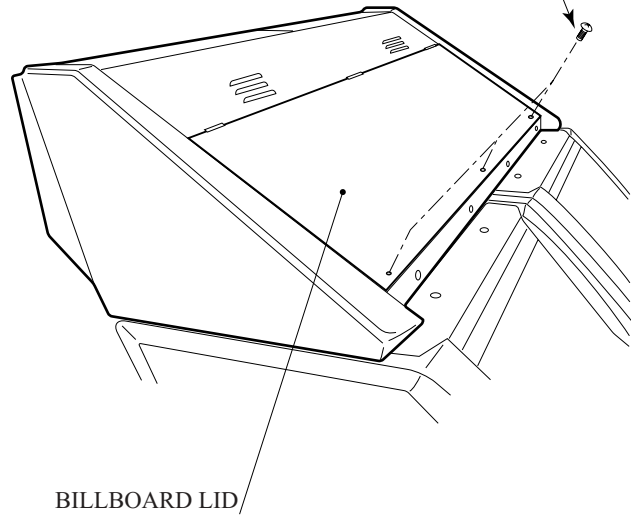
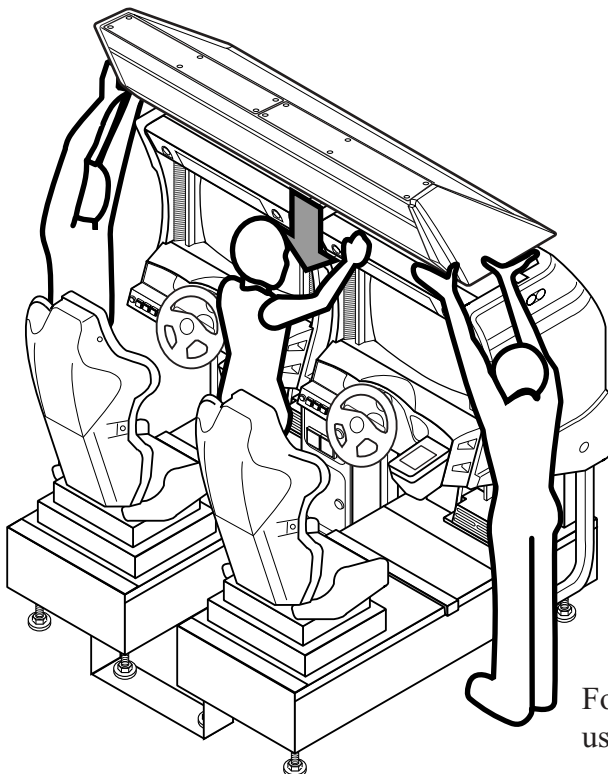

FIG. 6. 3 a



For performing work,  
use 3 or more workers.

- ③ By fastening 3 Hexagon Bolts to the inner part of the BILLBOARD inside, secure the BILLBOARD to the cabinet.
- ④ Secure the 2 BILLBOARD HOLDERS with 4 Hexagon Bolts for each to secure the cabinet and BILLBOARD.
- ⑤ Connect the left & right connectors. Close the BILLBOARD LID and secure with 3 Truss Screws.

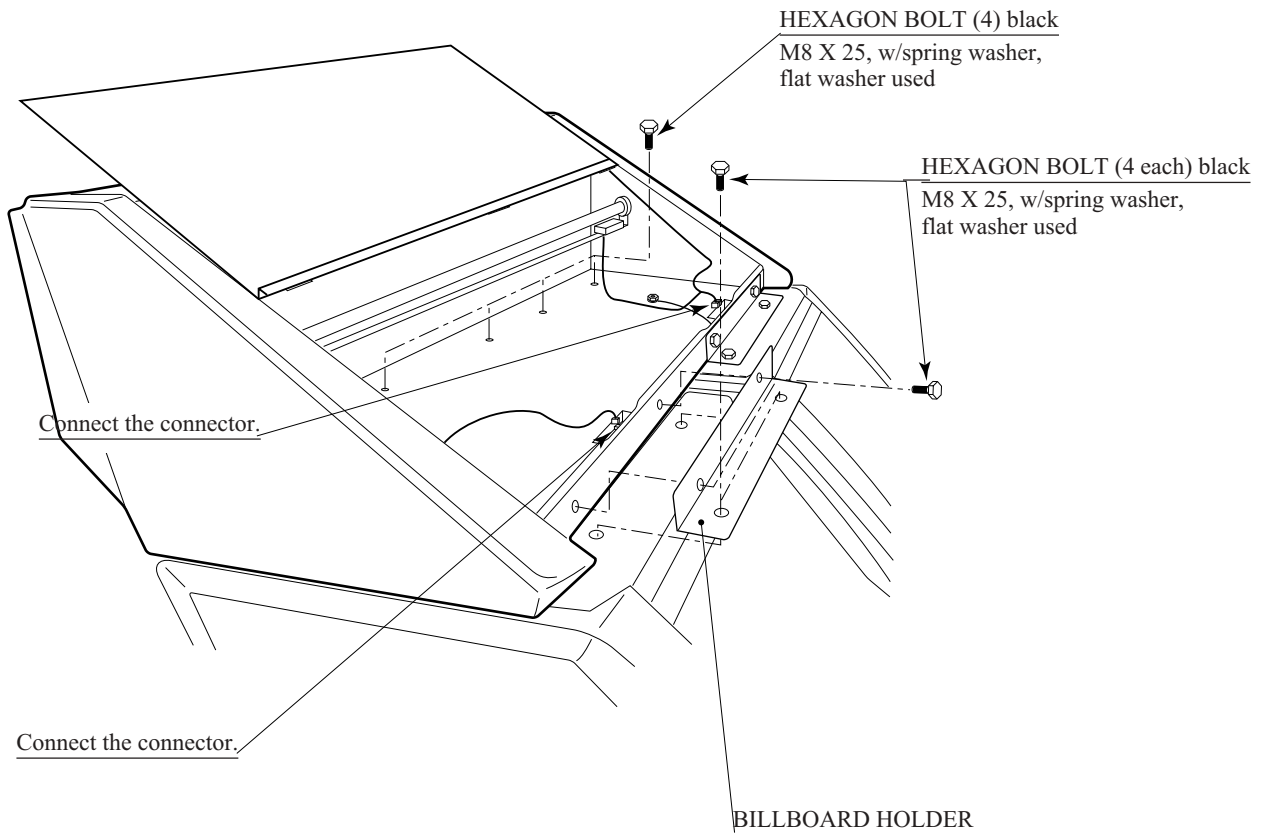

FIG. 6. 3 b

# 4

## INSTALLING THE AC COVERS (WIRING CONNECTION)



- Before starting to work, ensure that the Power SW is OFF. Failure to observe this can cause electric shock and short circuit hazards.
- Use care so as not to damage wirings. Damaged wiring can cause electric shock and short circuit hazards.

The AC cover is used for protecting the wiring and optic fiber cables. When performing the work, be very careful so as not to cause damage by catching them. Pay due attention to handling optic fiber cables in particular. Ensure not to cause breakage to the cables due to excessive bending.

- ① Attach AC COVER A to the back of the cabinet (Fig. 6.4) by securing with 5 screws.
- ② Make wiring connections between both cabinets & the coin chute tower. Insert the supplied wiring connectors to the corresponding ones which have an identical color and the same number of pins.
- ③ Insert the optic fiber cables to the optic fiber connectors in a manner as applicable. There are "TX" and "RX" connectors. Make sure to connect the "TX" connector of one cabinet to the "RX" connector of the other cabinet (see Sec. 20).
- ④ Secure the wiring and optic fiber cable with cord clamps in AC COVER A.
- ⑤ Install AC COVER B. Insert AC COVER B to AC COVER A from above and secure with 4 screws.

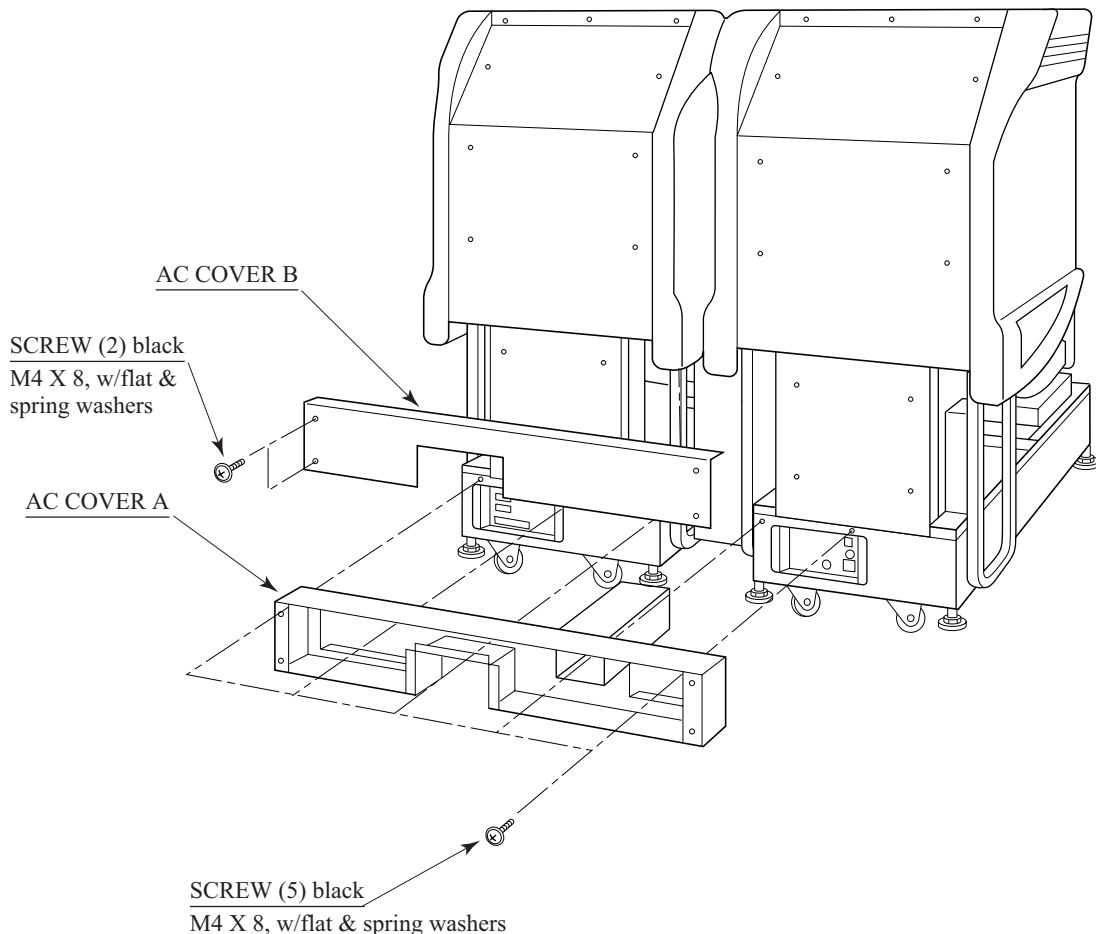

FIG. 6. 4



# 5

## POWER SUPPLY, AND EARTH CONNECTION



- Be sure to independently use the power supply socket outlet equipped with an Earth Leakage Breaker. Using a power supply without an Earth Leakage Breaker can cause a fire when electric leakage occurs.
- Ensure that the "accurately grounded indoor earth terminal" and the earth wire cable are available (except in the case where a power cord plug with earth is used). This product is equipped with the earth terminal. Connect the earth terminal and the indoor earth terminal with the prepared cable. If the grounding work is not performed appropriately, customers can be subjected to an electric shock, and the product's functioning may not be stable.
- Ensure that the power cord and earth wire are not exposed on the surface (passage, etc.). If exposed, they can be caught and are susceptible to damage. If damaged, the cord and wire can cause electric shock and short circuit accidents. Ensure that the wiring position is not in the customer's passage way or the wiring has protective covering.
- After wiring power cord on the floor, be sure to protect the power cord. Exposed power cord is susceptible to damage and causes an electric shock accident.

The AC Unit is mounted on the 1P COCKPIT. The AC Unit incorporates the Main SW, earth terminal and Inlet.

- ① Ensure that the Main SW is OFF.

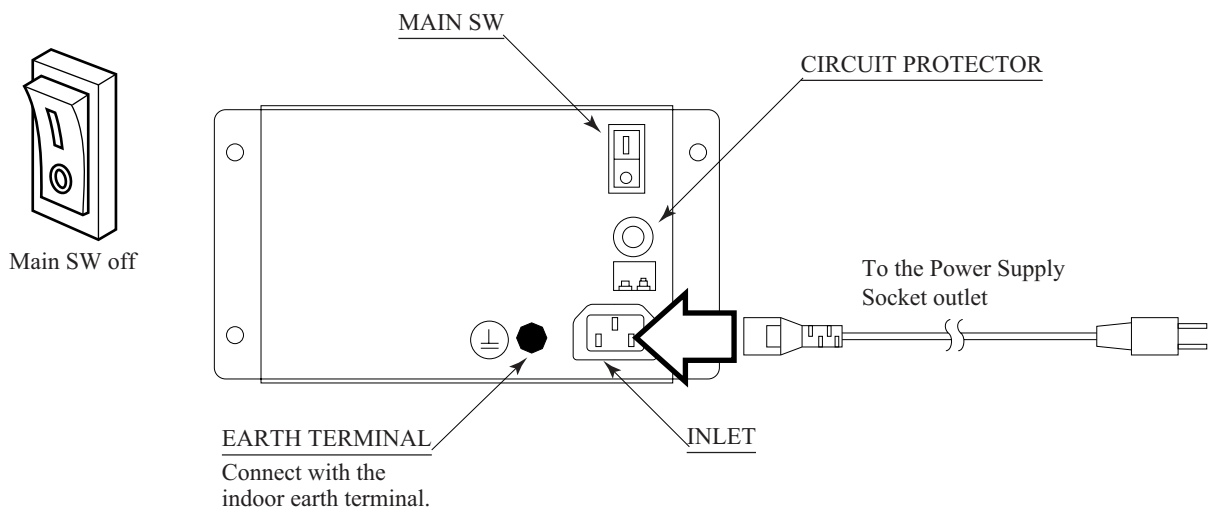
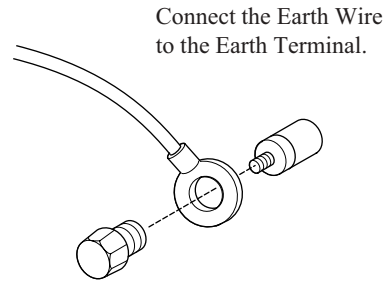

FIG. 6. 5 a AC unit

- ② Connect one end of the earth wire to the AC Unit earth terminal, and the other end to the indoor earth terminal. The AC Unit earth terminal has a Bolt and Nut combination. Take off the Nut, pass the earth wire through the Bolt, and fasten the Nut.

Note that the Earth Wire is incorporated in the Power Cord for the Areas of AC 120V (USA) and AC 220 ~ 240V, and therefore, this procedure is not necessary.



Connect the Earth Wire to the Earth Terminal.

FIG. 6. 5 b Earth Wire Connection

- ③ Firmly insert the power plug into the socket outlet. Insert the opposite side of Power Cord plug to the AC Unit's connector ("INLET").
- ④ Perform wiring for the Power Cord and Earth Wire. Install protective covering for the Power Cord and Earth Wire.

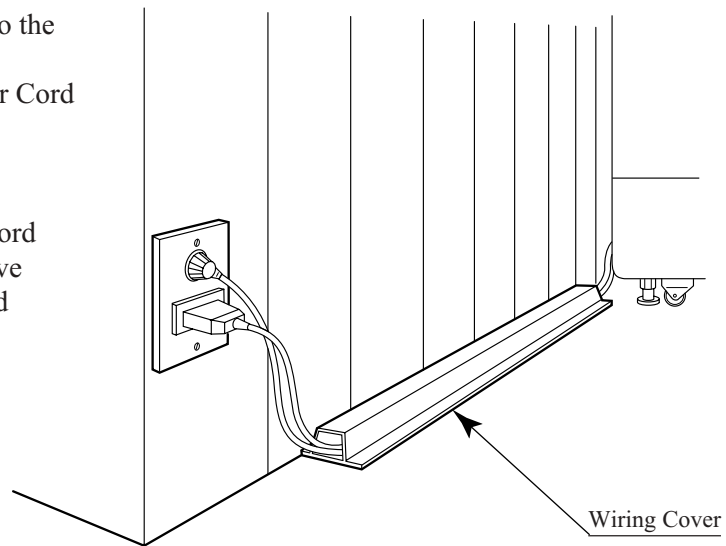
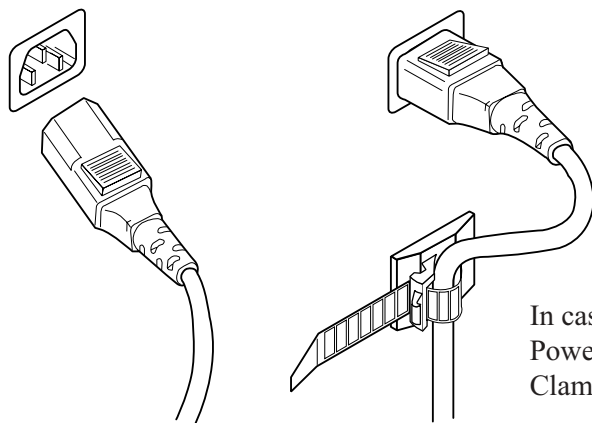

FIG. 6. 5 c Connecting Power Cord and Earth Wire



In case the Power Plug is apt to come out of place, secure the Power Cord to the periphery of the AC Unit with the Cord Clamp (an accessory).

HOW TO USE THE CORD CLAMP

# 6

## TURNING POWER ON

Turning the AC UNIT's MAIN SW on will cause the machine to start the POWER ON check and GAME BOARD SYSTEM check automatically.

In the POWER ON check, the steering wheel turns left and right, then returns to the centering position and stops. In this check, the values of V. R. inside the control panel are corrected. Until the check is finished (the steering wheel stops automatically), do not touch the steering wheel or play the game.

If you do, the steering wheel reaction during the game (reaction at the time of a course-out or crashing) can not be obtained correctly.

In a case of an abnormal reaction during the game, turn the power on again from the beginning and complete the power-on check.

Note that turning power on when the Steering Wheel is fully turned right or left may sometimes not allow for performing power on check satisfactorily. Ensure the Steering Wheel is in the centering position, and then turn on power.

During game board system checking, the check mode will appear on the monitor. After one minute, the screen proceeds to the network check.

During network checking, "CHECKING NETWORK NOW" is displayed on the screen. When the network checking is finished, the DEMO mode will appear on the monitor screen.

After 30 seconds, if the network check is not finished, check connections for Communication.

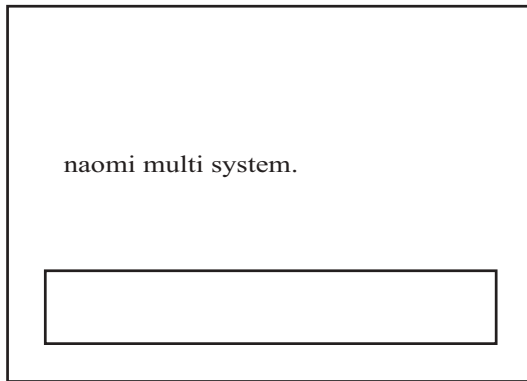

GAME BOARD SYSTEM CHECK SCREEN

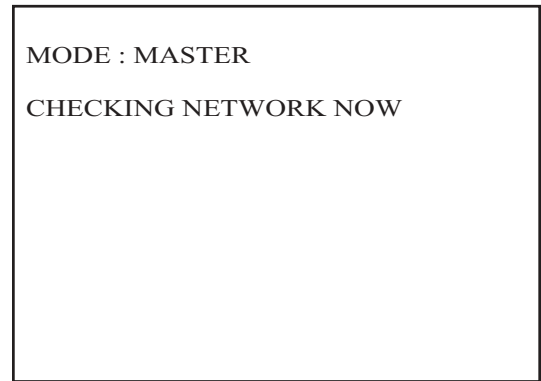

NETWORK CHECK SCREEN

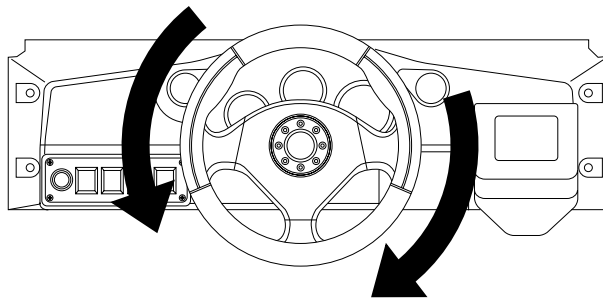

The steering wheel turns left/right automatically.

FIG. 6. 6



## ASSEMBLING CHECK

In the TEST MODE, ascertain that the assembly has been made correctly and IC BD. is satisfactory (refer to Section 9).

In the test mode, perform the following test:

### (1) MEMORY TEST

```

RAM TEST

IC29 GOOD
IC35 GOOD
IC16 GOOD IC18 GOOD
IC20 GOOD IC22 GOOD
IC09 GOOD IC10 GOOD
IC11 GOOD IC12 GOOD

PRESS TEST BUTTON TO EXIT

```

Selecting the RAM TEST on the system test mode menu screen causes the on-board memory to be tested automatically. The game board is satisfactory if the display beside each IC No. shows GOOD.

### (2) INPUT TEST

```

A° INPUT TEST A°
- SYSTEM SWITCH -
CHUTE #1 OFF CHUTE #2 OFF
TEST OFF B TEST OFF
SERVICE OFF B SERVICE OFF
- GAME SWITCH -
START OFF
SC OFF TC OFF
ABS OFF IBS OFF
- WING SHIFT -
WING L ON WING R OFF
- ANALOG DEVICE -
HANDLE 7B H ACCEL 2E H
BRAKE 2F H
- OTHER DEVICE -
VISUAL MEMORY UNCONNECTED

PRESS SERVICE + TEST BUTTON TO EXIT

```

Selecting the INPUT TEST on the game test mode menu screen causes the screen (on which each switch and V.R. are tested) to be displayed. Press each switch. For the coin switch test, insert a coin from the coin inlet with the coin chute door open. If the display beside each switch indicates "ON," the switch and wiring connections are satisfactory. Check the display of V. R. value for the steering wheel and accelerator & brake. If the V. R. values are not satisfactory, refer to Sections 10 & 11.

### (3) OUTPUT TEST

```

A° OUTPUT TEST MENU A°

LAMP TEST
DRIVE BOARD TEST

-> EXIT TO SYSTEM TEST MODE

SELECT WITH SERVICE BUTTON
AND PRESS TEST BUTTON

```

The OUTPUT TEST menu screen in the game test mode allows Lamp and Motor to be checked. Check if Lamp and Motor are satisfactory.

#### (4) SOUND TEST

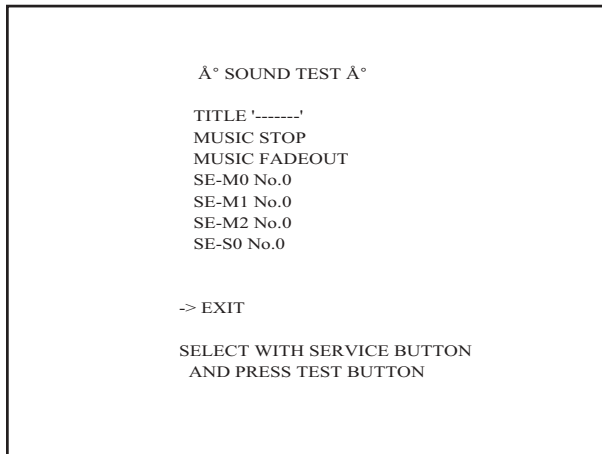

In the game test mode, selecting SOUND TEST causes the screen (on which sound related BD and wiring connections are tested) to be displayed. Check if the sound is satisfactorily emitted from each speaker and the sound volume is appropriate.

#### (5) C.R.T. TEST

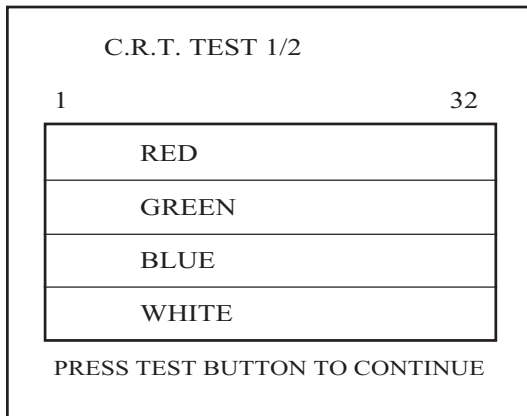

In the system test mode menu, selecting C.R.T. TEST allows the screen (on which the monitor is tested) to be displayed. Although the monitor adjustments have been made at the time of shipment from the factory, color deviation, etc., may occur due to the effect caused by geomagnetism, the location building's steel frames and other game machines in the periphery. By watching the test mode screen, make judgment as to whether an adjustment is needed. If it is necessary, adjust the monitor by referring to Section 14. Use the DEMAG SW to remove color deviation due to magnetization. (see Sec. 9)

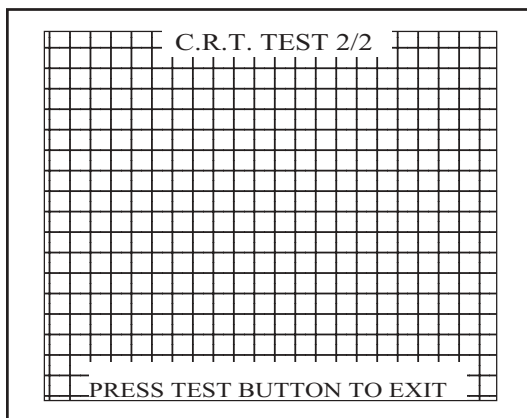

Perform the above inspections also at the time of monthly inspection.

## 7. PRECAUTIONS TO BE HEEDED WHEN MOVING THE MACHINE



WARNING!

- When moving the machine, be sure to unplug the power plug. Moving the machine with the plug as is inserted can damage the power cord, and cause fire and electric shock hazards.
- When moving the machine on the floor, retract the Adjusters and ensure that Casters make contact with the floor. During transportation, pay careful attention so that Casters do not tread power cords and earth wires. Damaging the power cords can cause electric shock and short circuit hazards.
- When moving the machine, do not push the cabinet from the left/right direction. Pushing the cabinet from the left/right direction can cause the cabinet to fall down, resulting in injury and or parts damage.



CAUTION!

Do not push glass parts (CRT, etc.) or plastic parts. Failure to observe this may damage parts and cause injury due to an accident or fragments resulting from damage.



IMPORTANT!

When transporting the product in places with steps, disassemble into each unit before transporting. Inclining the product in an as is assembled condition or placing the cabinet in places with steps can damage the unit's joining portions.

When transporting the product in places with steps or step-like differences in grade, disassemble into each unit before transporting.

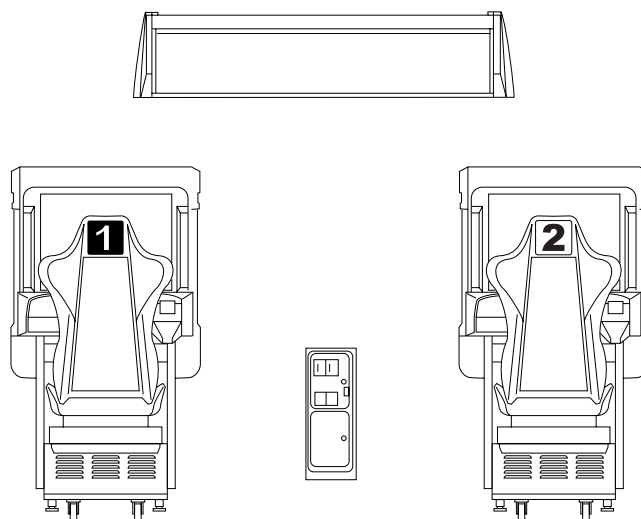
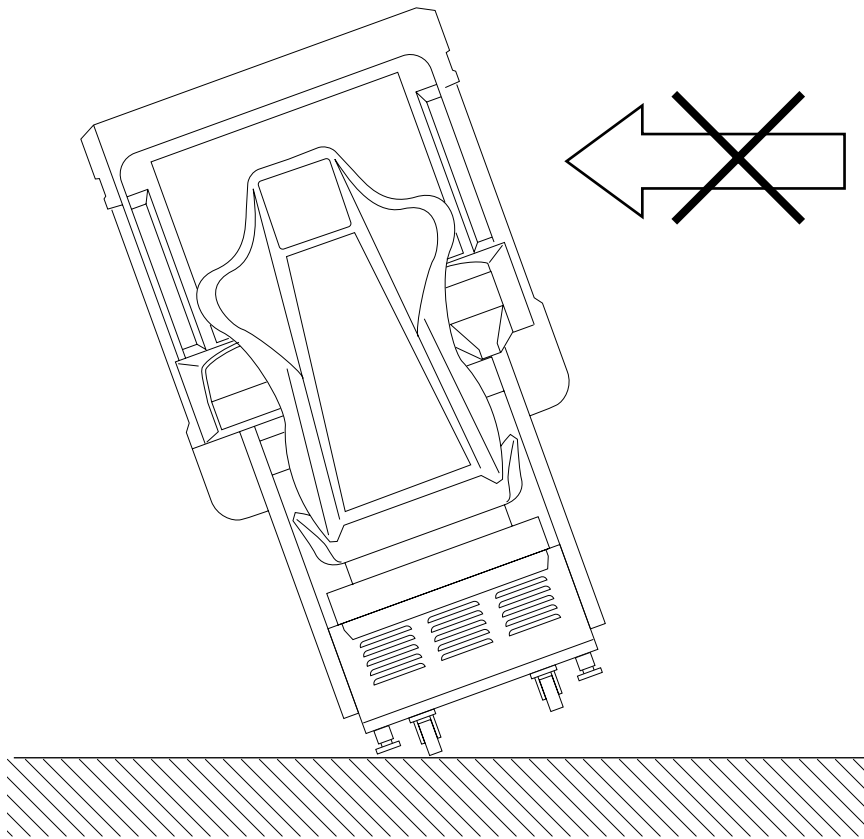

FIG. 7 a





Do not push an independent (detached) cockpit from the left/right direction.

FIG. 7 b

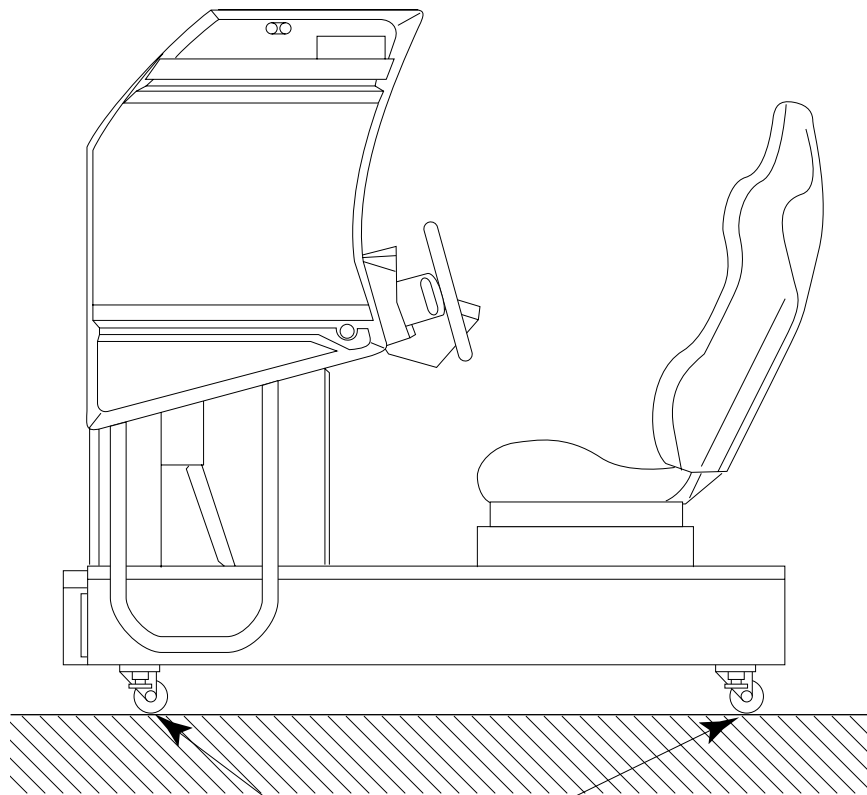

Have casters make contact with the floor.

FIG. 7 c

## 8. CONTENTS OF GAME

The following explanations apply to the case the product is functioning satisfactorily. Should there be any moves different from the following contents, some sort of faults may have occurred. Immediately look into the cause of the fault and eliminate the cause thereof to ensure satisfactory operation.

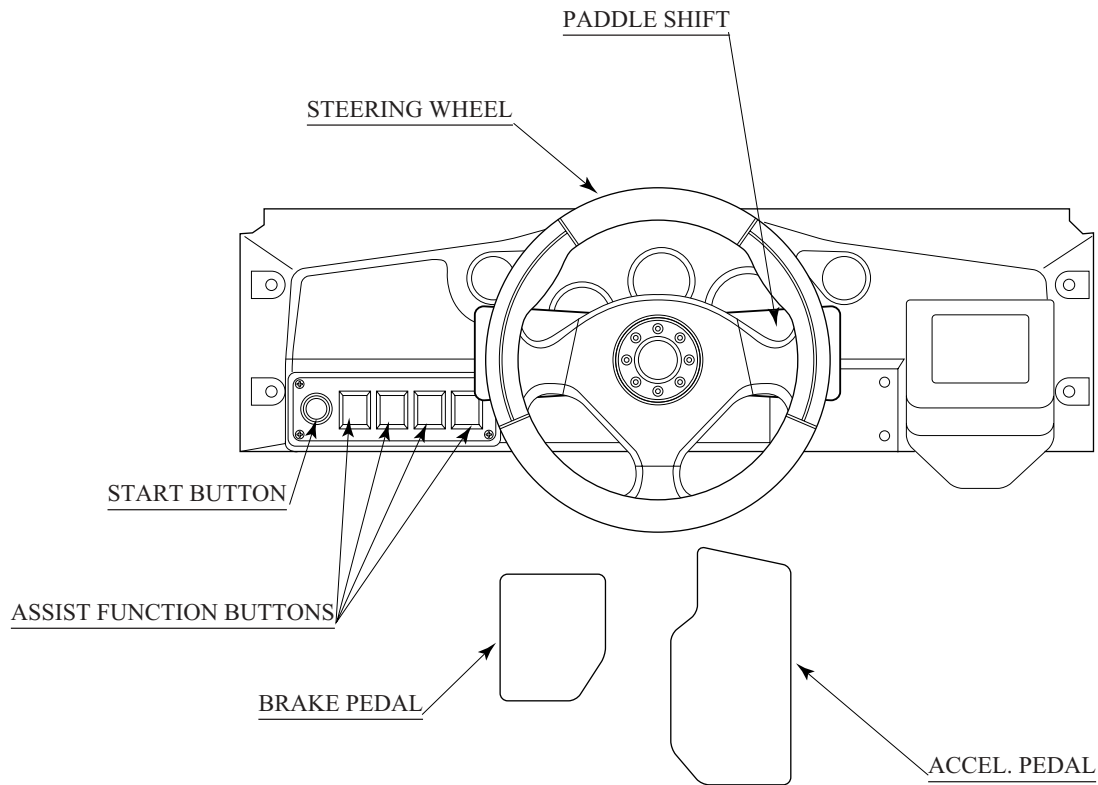

- From GAME START up to the end of SELECT

Insert a credit worth number of coins. Inserting one play worth of coins causes the Start button to flash. When the Start button is pressed, the credit is consumed. In case the credit is less than one play worth, the Start button goes off.

• In case of single play >

● Select Game Contents

- 1) Select the course from among the 6 courses in the Course Select screen.

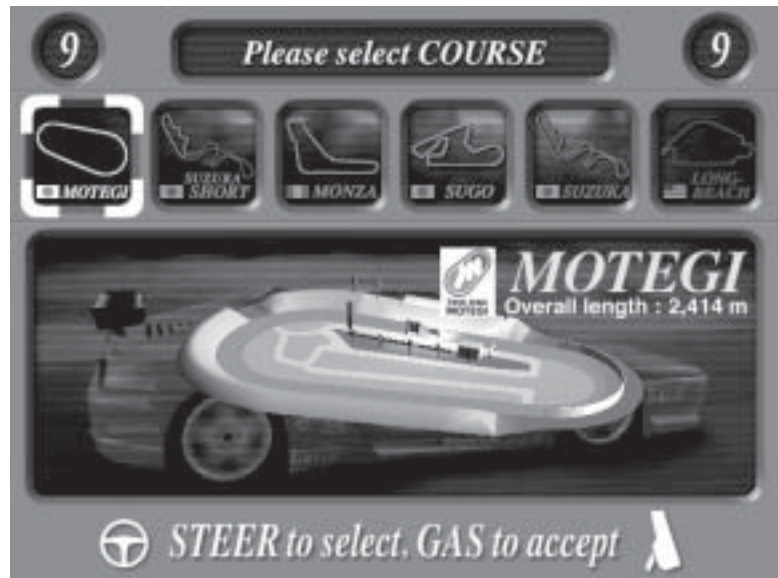

Turn the Steering Wheel left and right to choose and decide the selection by stepping on the Accelerator Pedal.

- 2) Select the level from the 2 levels in the Level Select screen.

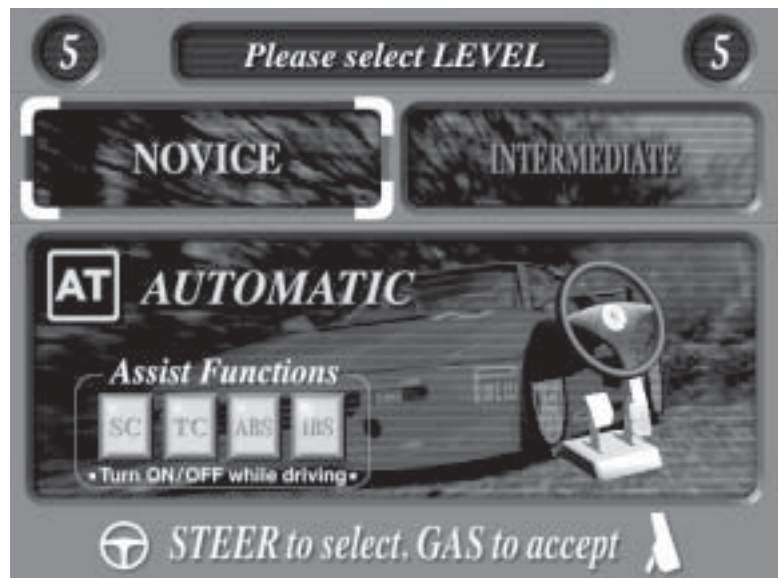

The following levels are available in single play.

NOVICE	<ul style="list-style-type: none"><li>• Automatic</li><li>• All Assist functions are offered.</li></ul>
INTERMEDIATE	<ul style="list-style-type: none"><li>• Semi-Automatic (Paddle-shift)</li><li>• All Assist functions except IBS are offered.</li></ul>

## About Assist Functions



### Stability Control

Stabilizes and controls position of the car in a cornering.



### Traction Control

Controls the powertrain in a wheelspin, and stabilizes the control of the car.



### Anti-lock Brake System

Prevents your tires from locking when you brake.



### Intelligent Brake System

Automatic braking before a curve.

Each Assist Function can be turned ON and OFF while driving.

- 3) Select the mode from among the 3 modes in the Mode Select screen.



The following game modes are available in single play.

TRAINING MODE:	The course is navigated by the screen displays & voices and suitable for beginners to learn how to drive, the characteristics of the car, and to remember the course. In this mode, finishing the predetermined laps within the time limit to goal results in a game over.
DRIVING MODE:	This mode is single run in the circuit and is suitable for the player to brush up his driving technique. No navigation is available. In this mode, the game is over when the time is up and can be continued by inserting additional coins.
RACE MODE:	This mode is suitable for the player who wishes to experiment in driving technique in the practical race. In this mode, finishing the predetermined raps within the time limit to goal results in a game over.

\*Additional 100 seconds per one credit is added when continued.

< In case of communication play >

Press START button during the entry acceptance to enter the Communication Play mode.



- Select Game Contents

- 1) Select the course from among the 6 courses in the Course Select screen.



During the Communication Play, the following communication conditions are available. Setting of the communication conditions can be changed in the GAME TEST mode.

- HEAT : An exciting, nip-and tuck race from the game start to the end.
- AID : By taking advantage of the Assist Functions, the NOVICE (AT) player can run the advanced player close.
- PRO : Offers a hotly contested game under the equal condition among all cars.

2) Select the level from among 3 levels in the Level Select screen.

< In case of HEAT >



NOVICE	<ul style="list-style-type: none"> <li>• Automatic</li> <li>• All Assist functions are offered.</li> </ul>
INTERMEDIATE	<ul style="list-style-type: none"> <li>• Semi-Automatic (Paddle-shift)</li> <li>• All Assist functions except IBS are offered.</li> </ul>
PROFESSIONAL	<ul style="list-style-type: none"> <li>• Semi-Automatic (Paddle-shift)</li> <li>• All Assist functions except IBS are offered.</li> <li>• In this mode, Handicap is not given.</li> </ul>



< In case of AID or PRO >



●In case of AID

NOVICE	<ul style="list-style-type: none"> <li>• Automatic</li> <li>• All Assist functions are offered.</li> </ul>
INTERMEDIATE	<ul style="list-style-type: none"> <li>• Semi-Automatic (Paddle-shift)</li> <li>• All Assist functions except IBS are offered.</li> <li>• In this mode, Handicap is not given.</li> </ul>

●In case of PRO

NOVICE	<ul style="list-style-type: none"> <li>• Automatic</li> <li>• All Assist functions are offered.</li> <li>• In this mode, Handicap is not given.</li> </ul>
INTERMEDIATE	<ul style="list-style-type: none"> <li>• Semi-Automatic (Paddle-shift)</li> <li>• All Assist functions except IBS are offered.</li> <li>• In this mode, Handicap is not given.</li> </ul>



## 9. EXPLANATION OF TEST AND DATA DISPLAY

By operating the switch unit, periodically perform the tests and data check. When installing the machine initially or collecting cash, or when the machine does not function correctly, perform checking in accordance with the explanations given in this section.

The following shows tests and modes that should be utilized as applicable.

NAOMI GAME BOARD is used for the product. The Test Mode of this system consists of the System Test Mode for the system to execute SELF-TEST, COIN ASSIGNMENTS, etc. used in common for the machines employing the NAOMI BOARD, and the Game Test Mode for the specific product to execute Input/Output test for the operation equipment, difficulty setting, etc.

TABLE 9 EXPLANATION OF TEST MODE

ITEMS	DESCRIPTION	REFERENCE SECTIONS
INSTALLATION OF MACHINE	When the machine is installed, perform the following: 1. Check to ensure each is the standard setting at shipment. 2. Check each Input equipment in the INPUT TEST mode. 3. Check each Output equipment in the OUTPUT TEST mode. 4. Test on-IC-Board IC's in the SELF-TEST mode.	9 - 2 9 - 3A 9 - 2/2, 9 - 3D 9 - 3 F, G 9 - 2/1, 9 - 2/10
MEMORY	This test is automatically executed by selecting RAM TEST, or ROM BOARD TEST in the Menu mode.	9 - 2/1, 9 - 2/10
PERIODIC SERVICING	Periodically perform the following: 1. MEMORY TEST 2. Ascertain each setting. 3. To test each Input equipment in the INPUT TEST mode. 4. To test each Output equipment in the OUTPUT TEST mode.	9 - 2/1, 9 - 2/10 9 - 2/2, 9 - 3 A 9 - 3 A 9 - 3 B
CONTROL SYSTEM	1. To check each Input equipment in the INPUT TEST mode. 2. Adjust or replace each Input equipment. 3. If the problem still remains unsolved, check each equipment's mechanism movements.	9 - 2/2, 9 - 3 A 10, 11, 12 9 - 3 E
MONITOR	In the Monitor Adjustment mode, check to see if Monitor (Projector) adjustments are appropriate.	9 - 2/4 14
IC BOARD	1. MEMORY TEST 2. In the SOUND TEST mode, check the sound related ROMs.	9 - 2/1, 9 - 2/10 9 - 3 C
DATA CHECK	Check such data as game play time and histogram to adjust the difficulty level, etc.	9 - 2/7 9 - 3 E

9 - 1 SWITCH UNIT AND COIN METER



Never touch places other than those specified. Touching places not specified can cause electric shock and short circuit accidents.



- Adjust to the optimum sound volume by considering the environmental requirements of the installation location.
- If the COIN METER and the game board are electrically disconnected, game play is not possible.

SWITCH UNIT

Open the coin chute door, and the switch unit shown will appear. The function of each SW is as follows:

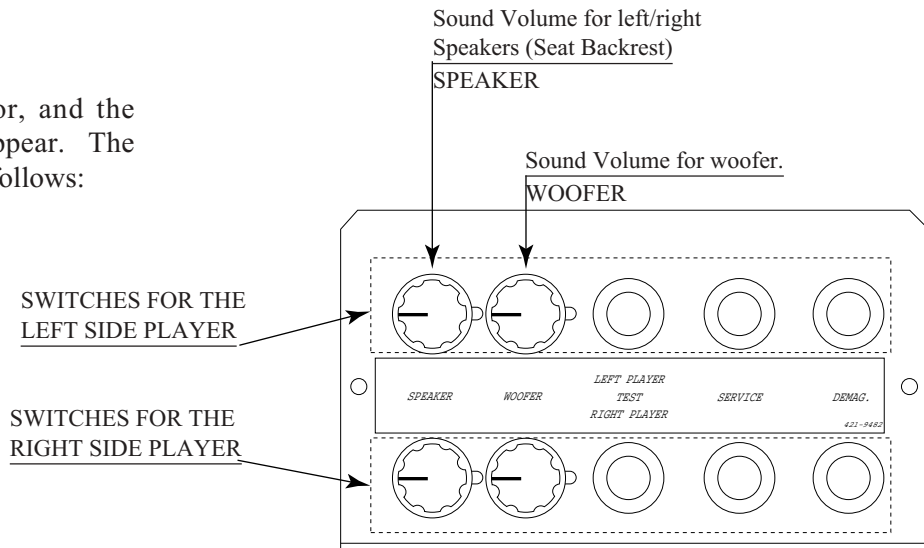

FIG. 9. 1 a SWITCH UNIT

TEST BUTTON:  
TEST

For the handling of the test button, refer to the following pages.

SERVICE BUTTON:  
SERVICE

Gives credits without registering on the coin meter.

DEMAGNETIZER BUTTON:  
DEMAG

Eliminates the on-screen color unevenness due to magnetization of CRT. First use this SW before performing the monitor's color adjustment.

COIN METER

Open the Cashbox Door by using the key to have the Coin Meter appear underneath the Cashbox.

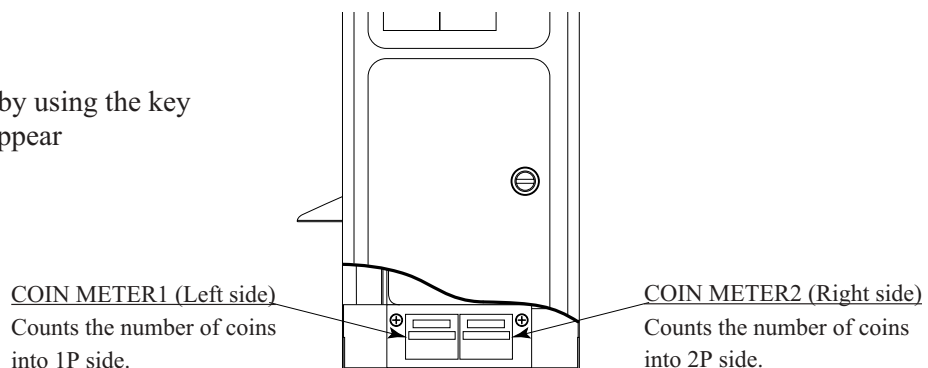

FIG. 9. 1 b COIN METER

## 9 - 2 SYSTEM TEST MODE



The contents of setting changes in SYSTEM ASSIGNMENTS, COIN ASSIGNMENTS, and GAME TEST MODE are stored when the test mode is EXITed. If the power is turned off before EXITing, the contents of setting changes are ineffective. Be very careful of this point.

This test mode mainly allows the IC Board to be checked for accurate functioning, monitor color to be adjusted as well as COIN ASSIGNMENTS and GAME ASSIGNMENTS to be adjusted.

### TEST ITEM SELECT

- 1) After turning power on, press the TEST button to have the following test item menu displayed. Although the menu is displayed on all of the 3 monitors (front, left and right), perform work by watching the front monitor only.

```
SYSTEM MENU
XXXXX VERSION

RAM TEST
JVS TEST
SOUND TEST
C.R.T. TEST
SYSTEM ASSIGNMENTS
COIN ASSIGNMENTS
BOOKKEEPING
BACKUP DATA CLEAR
CLOCK SETTING

ROM BOARD TEST
GAME TEST MODE
[XXXXXX XXXXXX XXXXXX XXXXXX]

-> EXIT

SELECT WITH SERVICE BUTTON
AND
PRESS TEST BUTTON
```

- 2) Press the SERVICE button to move the arrow. Bring the arrow to the desired item and press the TEST button.
- 3) Upon finishing the test, bring the arrow to EXIT and press the TEST button to return to the Game mode.

## ① RAM TEST

This allows for checking the functioning of the RAM on the NAOMI Main BD.  
"GOOD" is displayed for satisfactory RAMs, and "BAD" is indicated for irregular RAMs, if any.

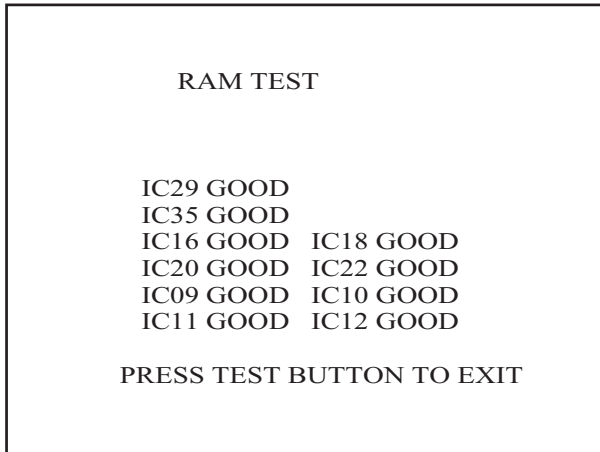

During test, "TESTING NOW" is displayed.  
Press the TEST button to return to the menu mode.

## ② JVS TEST

In this test, Specifications of the I/O Board connected to NAOMI can be checked, and INPUT TEST can be performed. First, I/O Board Specifications are displayed.

```

      JVS TEST
      INPUT TEST          (A)
      NEXT NODE          (B)
      -> EXIT             (C)
NODE   1/1
NAME   SEGA ENTERPRISES,LTD.
      837-13741 I/O CONTROL BD
      Ver0.15
      99/06
CMD VER  1.1
JVS VER  2.0
COM VER  1.0
SWITCH  2PLAYER(S) 12BITS
COIN    2SLOT
ANALOG  8CH
ROTARY  0CH
KEYCODE 0
SCREEN  X:0 Y:0 CH:0
CARD   OSLOT
HOPPER OUT 0CH
DRIVER OUT 22 SLOT
ANALOG OUT 0 CH
CHARACTER CHARA:0 LINE:0
BACKUP  0

      SELECT WITH SERVICE BUTTON
      AND
      PRESS TEST BUTTON
  
```

Select with the SERVICE button and press the TEST button.

- (A) INPUT TEST : Proceeds to the INPUT TEST of I/O BOARD being displayed.
- (B) NEXT NODE : In the case where more than 2 I/O Boards are connected, proceeds to the next I/O Board. Note that it does not function in this product.
- (C) EXIT : Returns to the menu mode.

### INPUT TEST SCREEN

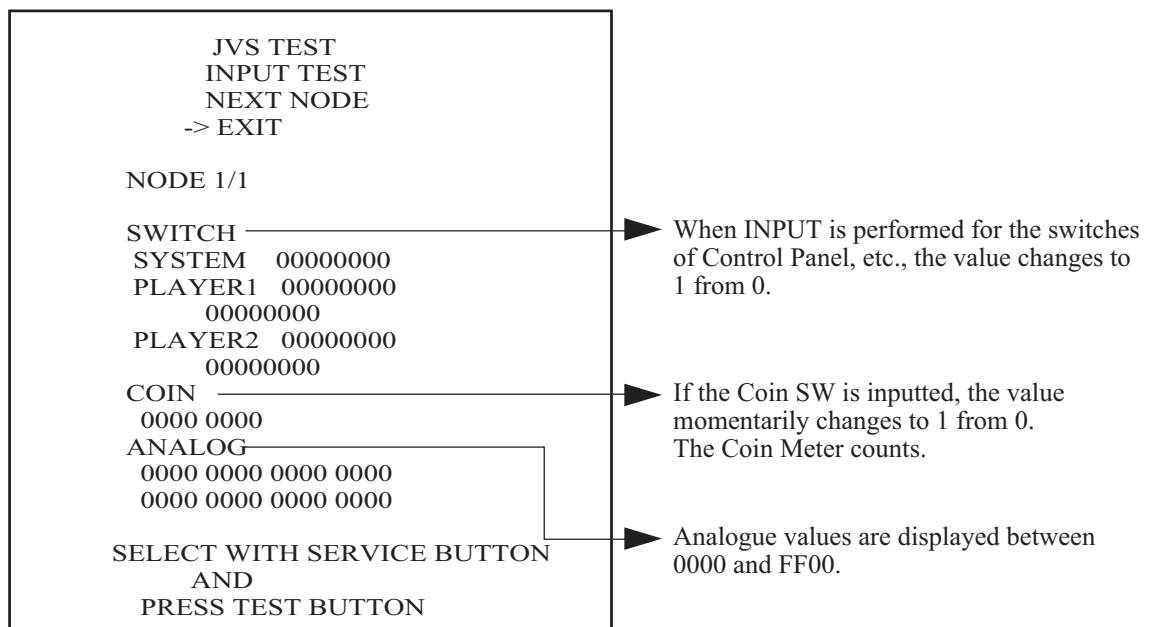

### ③ SOUND TEST

Sound Output test can be performed. Beep sounds can be emitted from each of left/right Speakers.

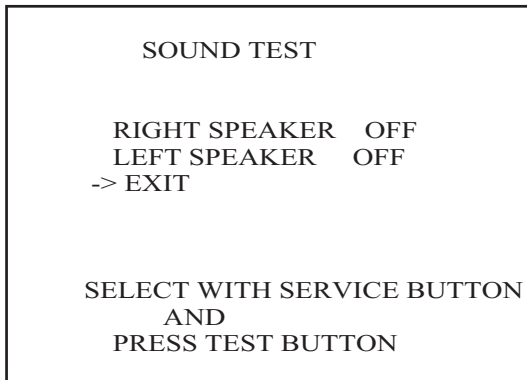

f Emitted from the right-hand side Speaker.  
f Emitted from the left-hand side Speaker.  
f Returns to the menu mode.

### ④ C.R.T. TEST

#### A) RGB COLOR ADJUSTMENT SCREEN

In this page, monitor color can be checked.

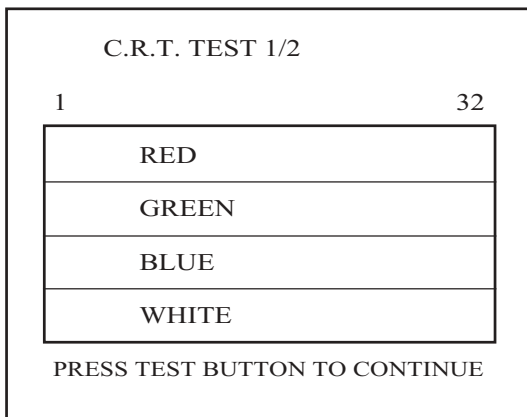

Each of red, green, and blue is the darkest at the leftmost end, and becomes brighter towards the right-hand end in 31 gradations. Monitor brightness is satisfactory if the white color bar is black at the left end and if it is white at the right end.

Press the TEST button to proceed to the next page.

#### B) MONITOR SIZE ADJUSTMENT SCREEN

In this page, monitor size can be checked.

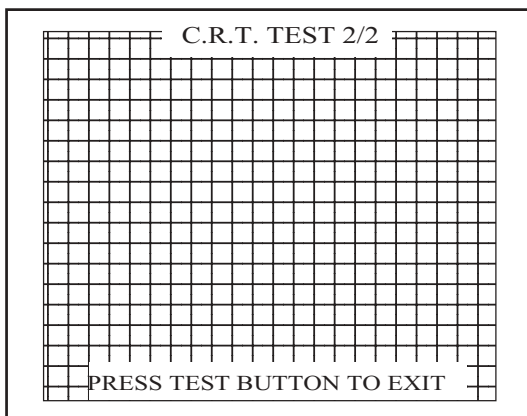

Adjust so that the checkered patterns do not go beyond the screen.

Press the TEST button to return to the menu mode.

## ⑤ SYSTEM ASSIGNMENTS



If the settings of CABINET TYPE and MONITOR TYPE are not suitable for the connected game, Error Message is displayed after turning power on and upon finishing the TEST mode, and in this case, game is not playable.

The setting of cabinet and board can be changed. Game related assignments such as game difficulty, etc. are performed in 2-3 GAME TEST MODE.

- 1) Press the SERVICE button to move the arrow. Bring the arrow to the desired item.
- 2) Press the TEST button to change the setting.
- 3) Upon finishing the setting, move the arrow to EXIT and press the TEST button.

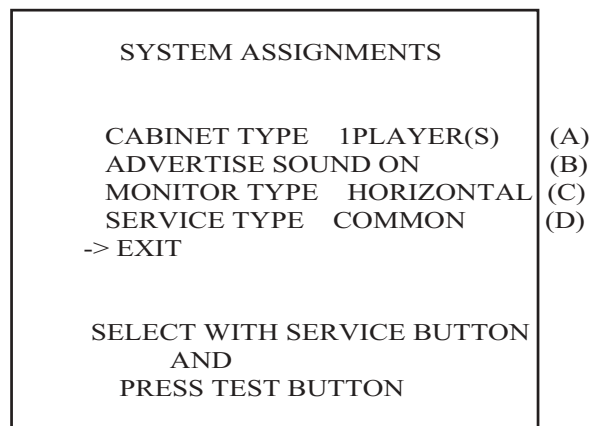

(A) CABINET TYPE (1PLAYER(S), 2PLAYER(S), 3PLAYER(S), 4PLAYER(S))

Sets number of players between 1 and 4. Set to 1 PLAYER(S).

(B) ADVERTISE SOUND (ON, OFF)

Sets whether ADVERTISE sound is to be emitted or not. Normally, set to ON.

(C) MONITOR TYPE (HORIZONTAL, VERTICAL)

Fix setting to HORIZONTAL.

(D) SERVICE TYPE (COMMON, INDIVIDUAL)

Set to COMMON.

## ⑥ COIN ASSIGNMENTS

In this mode, the setting of incremental credit increase as against coin insertion can be changed.

- 1) Press the SERVICE button to move the arrow. Bring the arrow to the desired item.
- 2) Press the TEST button to change the setting.
- 3) Upon finishing the setting, bring the arrow to EXIT and press the TEST button.

COIN ASSIGNMENTS	
COIN CHUTE TYPE    COMMON	(A)
COIN/CREDIT SETTING    #1	(B)
COIN CHUTE #1	
1 COIN 1 CREDIT	
COIN CHUTE #2	
1 COIN 1 CREDIT	
MANUAL SETTING	(C)
SEQUENCE SETTING	(G)
->EXIT	
SELECT WITH SERVICE BUTTON	
AND	
PRESS TEST BUTTON	

(COMMON SETTING)

### (A) COIN CHUTE TYPE (COMMON, INDIVIDUAL)

Set to COMMON.

Up to 2 Coin Chutes (#1 and #2) can be used and also, (B) COIN/CREDIT SETTING ratio can be set separately for #1 and #2.

### (B) COIN/CREDIT SETTING (#1 ~ #27)

Sets the credit increase increment per coin insertion. There are 27 settings from #1 to #27, expressed in OO credit(s) as against OO coins inserted. #27 refers to FREE PLAY.

For details, refer to Table 1 (COMMON).



## (C) MANUAL SETTING

The Credit's incremental increase settings as against a coin insertion are shown in further details than in (B) above (refer to Table 3). Also, note that when this MANUAL SETTING is performed, (B) COIN CREDIT setting becomes ineffective.

### MANUAL SETTING

COIN ASSIGNMENTS		
MANUAL SETTING		
COIN TO CREDIT	1	(D)
BONUS ADDER	NO BONUS ADDER	(E)
COIN CHUTE #1 MULTIPLIER		(F)
1 COIN COUNT AS 1 COIN		
COIN	1 2 3 4 5 6 7 8 9	
CREDIT	1 2 3 4 5 6 7 8 9	
COIN CHUTE #2 MULTIPLIER		(F)
1 COIN COUNT AS 1 COIN		
COIN	1 2 3 4 5 6 7 8 9	
CREDIT	1 2 3 4 5 6 7 8 9	
SEQUENCE SETTING		(G)
->EXIT		
SELECT WITH SERVICE BUTTON		
AND		
PRESS TEST BUTTON		

#### (D) COIN TO CREDIT

Determines COIN/CREDIT setting.

#### (E) BONUS ADDER

This sets how many coins should be inserted to obtain one SERVICE COIN.

#### (F) COIN CHUTE (#1 / #2) MULTIPLIER

This sets how many tokens one coin represents.

Table 1: COIN/CREDIT SETTING (COIN CHUTE COMMON TYPE)

NAME OF SETTING	COIN CHUTE 1		COIN CHUTE 2	
SETTING #1	1 COIN	1 CREDIT	1 COIN	1 CREDIT
SETTING #2	1 COIN	2 CREDITS	1 COIN	1 CREDIT
SETTING #3	1 COIN	3 CREDITS	1 COIN	1 CREDIT
SETTING #4	1 COIN	4 CREDITS	1 COIN	1 CREDIT
SETTING #5	1 COIN	5 CREDITS	1 COIN	1 CREDIT
SETTING #6	1 COIN	2 CREDITS	1 COIN	2 CREDITS
SETTING #7	1 COIN	5 CREDITS	1 COIN	2 CREDITS
SETTING #8	1 COIN	3 CREDITS	1 COIN	3 CREDITS
SETTING #9	1 COIN	4 CREDITS	1 COIN	4 CREDITS
SETTING #10	1 COIN	5 CREDITS	1 COIN	5 CREDITS
SETTING #11	1 COIN	6 CREDITS	1 COIN	6 CREDITS
SETTING #12	2 COINS	1 CREDIT	2 COINS	1 CREDIT
SETTING #13	1 COIN	1 CREDIT	2 COINS	1 CREDIT
SETTING #14	1 COIN	2 CREDITS	2 COINS	1 CREDIT
SETTING #15	1 COIN	1 CREDIT	1 COIN	1 CREDIT
	2 COINS	3 CREDITS	2 COINS	3 CREDITS
SETTING #16	1 COIN	3 CREDITS	1 COIN	1 CREDIT
			2 COINS	3 CREDITS
SETTING #17	3 COINS	1 CREDIT	3 COINS	1 CREDIT
SETTING #18	4 COINS	1 CREDIT	4 COINS	1 CREDIT
SETTING #19	1 COIN	1 CREDIT	1 COIN	1 CREDIT
	2 COINS	2 CREDITS	2 COINS	2 CREDITS
	3 COINS	3 CREDITS	3 COINS	3 CREDITS
	4 COINS	5 CREDITS	4 COINS	5 CREDITS
SETTING #20	1 COIN	5 CREDITS	1 COIN	1 CREDIT
			2 COINS	2 CREDITS
			3 COINS	3 CREDITS
			4 COINS	5 CREDITS
SETTING #21	5 COINS	1 CREDIT	5 COINS	1 CREDIT
SETTING #22	1 COIN	2 CREDITS	3 COINS	1 CREDIT
			5 COINS	2 CREDITS
SETTING #23	2 COINS	1 CREDIT	2 COINS	1 CREDIT
	4 COINS	2 CREDITS	4 COINS	2 CREDITS
	5 COINS	3 CREDITS	5 COINS	3 CREDITS
SETTING #24	1 COIN	3 CREDITS	2 COINS	1 CREDIT
			4 COINS	2 CREDITS
			5 COINS	3 CREDITS
SETTING #25	1 COIN	1 CREDIT	1 COIN	1 CREDIT
	2 COINS	2 CREDITS	2 COINS	2 CREDITS
	3 COINS	3 CREDITS	3 COINS	3 CREDITS
	4 COINS	4 CREDITS	4 COINS	4 CREDITS
	5 COINS	6 CREDITS	5 COINS	6 CREDITS
SETTING #26	1 COIN	6 CREDITS	1 COIN	1 CREDIT
			2 COINS	2 CREDITS
			3 COINS	3 CREDITS
			4 COINS	4 CREDITS
			5 COINS	6 CREDITS
SETTING #27	FREE PLAY		FREE PLAY	

Table 2: MANUAL SETTING

COIN TO CREDIT	1 COIN	1 CREDIT
	2 COIN	1 CREDIT
	3 COIN	1 CREDIT
	4 COIN	1 CREDIT
	5 COIN	1 CREDIT
	6 COIN	1 CREDIT
	7 COIN	1 CREDIT
	8 COIN	1 CREDIT
	9 COIN	1 CREDIT

BONUS ADDER	NO BONUS ADDER	
	2 COINS GIVE	1 EXTRA COIN
	3 COINS GIVE	1 EXTRA COIN
	4 COINS GIVE	1 EXTRA COIN
	5 COINS GIVE	1 EXTRA COIN
	6 COINS GIVE	1 EXTRA COIN
	7 COINS GIVE	1 EXTRA COIN
	8 COINS GIVE	1 EXTRA COIN
	9 COINS GIVE	1 EXTRA COIN

COIN CHUTE (#1 / #2) MULTIPLIER	1 COINS COUNTS AS	1 COIN
	1 COINS COUNTS AS	1 COIN
	1 COINS COUNTS AS	1 COIN
	1 COINS COUNTS AS	1 COIN
	1 COINS COUNTS AS	1 COIN
	1 COINS COUNTS AS	1 COIN
	1 COINS COUNTS AS	1 COIN
	1 COINS COUNTS AS	1 COIN
	1 COINS COUNTS AS	1 COIN
	1 COINS COUNTS AS	1 COIN

(G) SEQUENCE SETTING

Number of credits required for starting game, etc. can be set.  
Each sequence can be set between 1~5 credit(s).

```
COIN ASSIGNMENTS
SEQUENCE SETTING

SEQUENCE 1  2 CREDIT(S)
SEQUENCE 2  1 CREDIT(S)
SEQUENCE 3  1 CREDIT(S)
SEQUENCE 4  1 CREDIT(S)
SEQUENCE 5  1 CREDIT(S)
SEQUENCE 6  1 CREDIT(S)
SEQUENCE 7  1 CREDIT(S)
SEQUENCE 8  1 CREDIT(S)
-> EXIT
[XXXXXX XXXXXX XXXXXX XXXXXX]
DESCRIPTION OF SEQUENCE
1 CREDIT TO START
2 CREDIT TO CONTINUE
3 CREDIT TO PRINTOUT
4 NO USE
5 NO USE
6 NO USE
7 NO USE
8 NO USE

SELECT WITH SERVICE BUTTON
AND PRESS TEST BUTTON
```

SEQUENCE 1 : Number of credits required for game start.  
SEQUENCE 2 : Number of credits required for CONTINUE.  
SEQUENCE 3 ~ 8 : NOT USED.

## ⑦ BOOKKEEPING

- BOOKKEEPING 1/2

This allows such data as operating time/No. of coins inserted/ No. of credits to be checked.  
Perform work by watching the front monitor only.

BOOKKEEPING 1/2	
TOTAL TIME	
0D 00H 00M 00S	
CREDIT	0
COIN 1	0
COIN 2	0
COIN 3	0
COIN 4	0
TOTAL COIN	0
COIN CREDIT	0
SERVICE CREDIT	0
TOTAL CREDIT	0
PRESS TEST BUTTON TO CONTINUE	

Press the TEST button to proceed to BOOKKEEPING 2/2.

- BOOKKEEPING 2/2

Each sequence displays the frequency of functioning.

BOOKKEEPING 2/2	
P1 SEQ 1	0
P1 SEQ 2	0
P1 SEQ 3	0
P1 SEQ 4	0
P1 SEQ 5	0
P1 SEQ 6	0
P1 SEQ 7	0
P1 SEQ 8	0
PRESS TEST BUTTON TO EXIT	

P1 SEQ 1 :        Frequency of Game Start by the player.  
P1 SEQ 2 :        Frequency of CONTINUE by Player (Player 2)  
P1 SEQ 3 ~ 8 :    NOT USED.

## ⑧ BACKUP DATA CLEAR

Clears the contents of BOOKKEEPING (SYSTEM TEST MODE).  
The data regarding the coins, the credits, and the total time in the BOOKKEEPING in the GAME TEST Mode are also cleared.

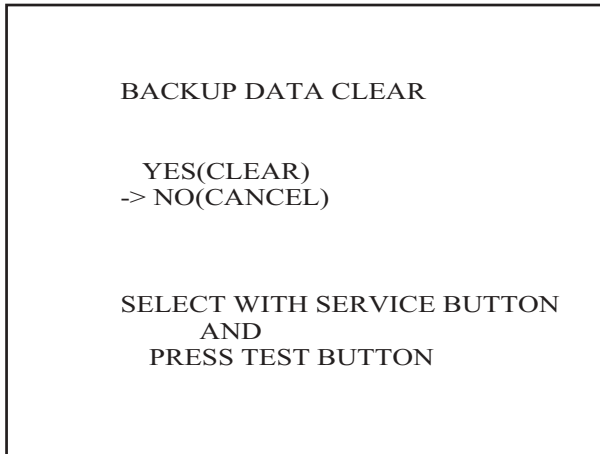

When clearing, bring the arrow to YES by using the SERVICE button and press the TEST button. Bring the arrow to NO and press the TEST button to have the menu mode return without clearing the data. COMPLETED is displayed when clearing is completed. Press the TEST button to return to the menu mode.

## ⑨ CLOCK SETTING

Set YEAR, MONTH, DAY, HOUR, and MINUTE for NAOMI Main BD.

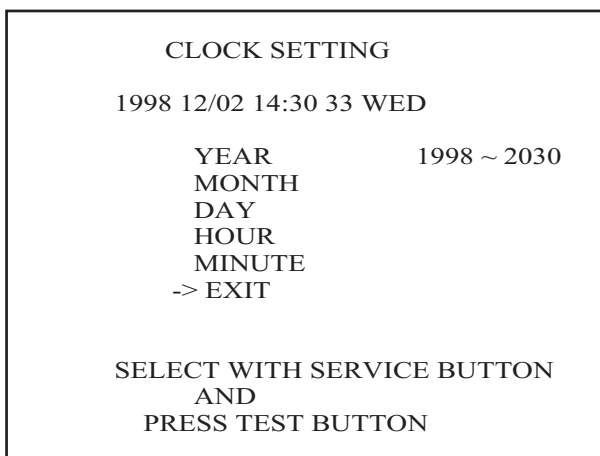

Select the desired item with the SERVICE button and press the TEST button to increase the value. Upon finishing the SETTING, bring the arrow to EXIT and press the TEST button to return to the menu mode.

## ⑩ ROM BOARD TEST

In this test, on-ROM-BD ROM check is executed. If GOOD is displayed, it is satisfactory. However, Program ROMs (IC22) do not display GOOD or BAD. BYTE and WORD refers to the check sum of each unit.

```
ROM BOARD TEST
[XXXXX XXXXX XXXXX]

NO. TYPE RESULT BYTE WORD
IC22 32M ---- XXXX XXXX
IC1  64M GOOD  XXXX XXXX
IC2  64M GOOD  XXXX XXXX
IC3  64M GOOD  XXXX XXXX
IC4  64M GOOD  XXXX XXXX
IC5  64M GOOD  XXXX XXXX
IC6  64M GOOD  XXXX XXXX
IC7  64M GOOD  XXXX XXXX
IC8  64M GOOD  XXXX XXXX
IC9  64M GOOD  XXXX XXXX
IC10 64M GOOD  XXXX XXXX
IC11 64M GOOD  XXXX XXXX
. . . . .
. . . . .
IC21 64M GOOD  XXXX XXXX

PRESS TEST BUTTON TO EXIT
```

Press the TEST button to return to the menu mode.

## 9 - 3 GAME TEST MODE

Press TEST Button to display the SYSTEM TEST MODE MENU.

```
SYSTEM MENU
XXXXX VERSION

RAM TEST
JVS TEST
SOUND TEST
C.R.T. TEST
SYSTEM ASSIGNMENTS
COIN ASSIGNMENTS
BOOKKEEPING
BACKUP DATA CLEAR
CLOCK SETTING

ROM BOARD TEST
GAME TEST MODE
[F355 CHALLENGE XXXXX]

-> EXIT

SELECT WITH SERVICE BUTTON
AND
PRESS TEST BUTTON
```

- By pressing SERVICE Button, move the arrow (->) to select the GAME TEST MODE. Press TEST Button to enter GAME TEST MODE.
- The screen displays the GAME TEST MODE MENU.

```
■ F355 Challenge APPLICATION TEST MENU ■

INPUT TEST
OUTPUT TEST
SOUND TEST
GAME ASSIGNMENTS
BOOKKEEPING
F355 BACKUP DATA CLEAR

-> EXIT TO SYSTEM TEST MODE

SELECT WITH SERVICE BUTTON
AND PRESS TESS BUTTON
```

- By pressing SERVICE Button, move the arrow (->) to select the desired item and press TEST Button to execute the selected item. Use the same procedure for selecting/executing the item in the following GAME TEST MODE.
- Select EXIT and press TEST Button to exit from the GAME TEST MODE and return to the SYSTEM TEST MODE MENU. Further, select EXIT and press TEST Button to finish SYSTEM TEST MODE and return to the normal mode.



## A) INPUT TEST

Selecting INPUT TEST displays the following screen on the monitor.

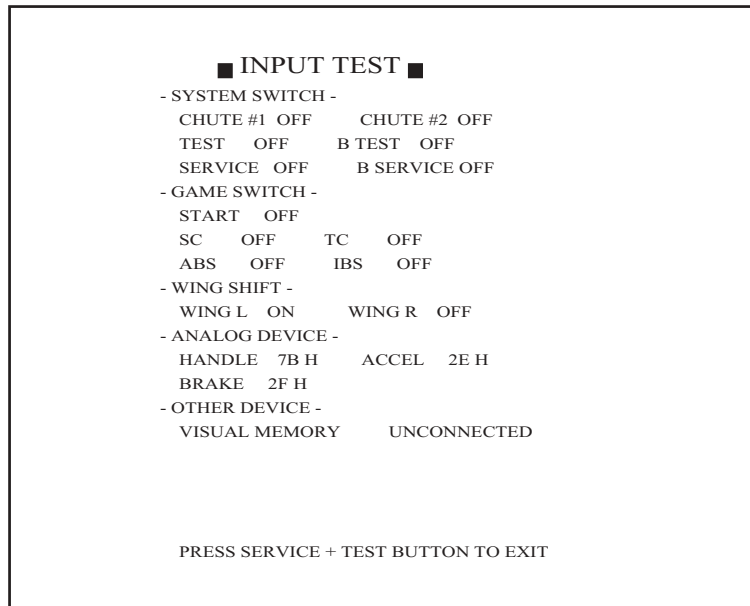

This test checks the satisfactory operation of each input device (SW or VR). When testing each input device, if the display changes from OFF to ON (or displays smoothly varying number for the VR inputs), operation is satisfactory. Pull WING L and R toward you to check if the display changes to ON. The B-TEST and the B SERVICE are on the filter BD. of Shield Case in which Game BD is put.

The Input devices that can be checked include COIN CHUTE, each button, Paddle Shift, Steering Wheel, each pedal (Acceleration, and Brake).

Press SERVICE Button and TEST Button simultaneously to return to the GAME TEST MODE MENU screen.

## B) OUTPUT TEST

This test displays the following screen on the monitor.

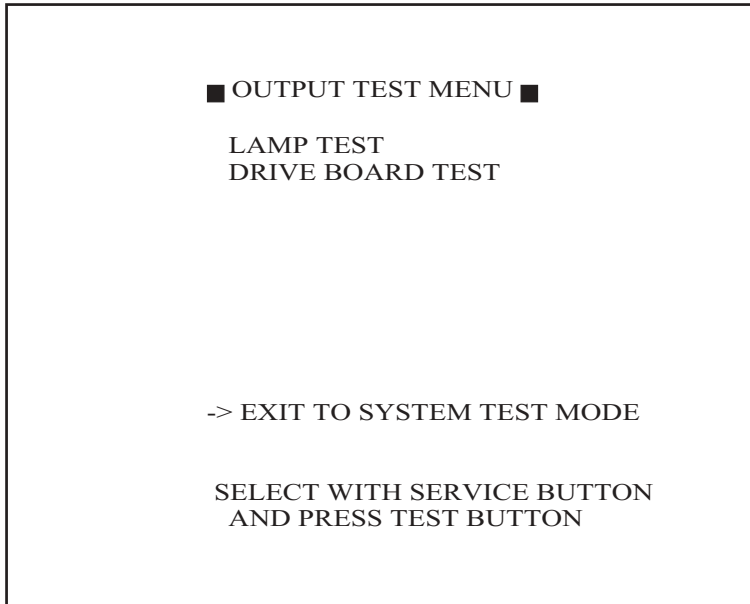

- The OUTPUT TEST displays the following screen on the monitor.
  - a) LAMP TEST
  - b) DRIVE BOARD TEST

### a) LAMP TEST

Selecting LAMP TEST displays the following screen on the monitor.

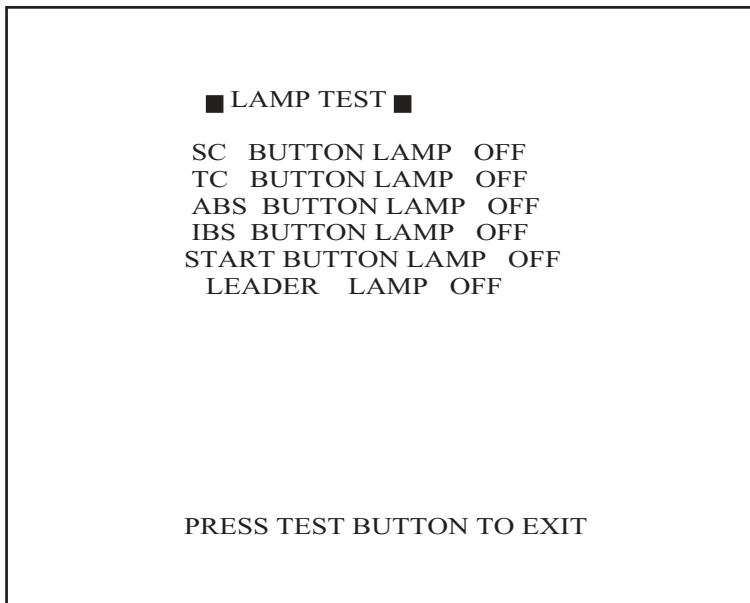

Upon entering the LAMP TEST, each lamp's display automatically changes to ON from OFF. At this time, if each lamp lights up, operation is satisfactory. Press TEST Button to return to GAME TEST MODE MENU screen.

## b) DRIVE BOARD TEST

Selecting DRIVE BOARD TEST causes the following to be displayed.

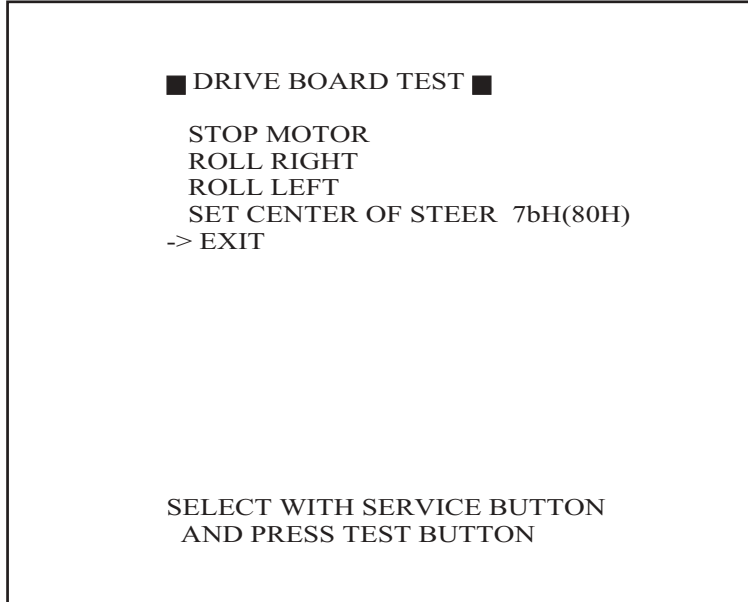

In ROLL RIGHT and ROLL LEFT, check to see if the motor turns the Steering Wheel clockwise and counterclockwise. After having confirmed satisfactory motor operation, stop the motor by selecting STOP MOTOR. Set the center values of the Steering Wheel in the SET CENTER OF STEER. With the Steering Wheel in the centering position, press TEST Button to set the Volume value as the center value. Ensure that the value can be set within  $80H \pm 10H$ .

## c) SOUND TEST

Selecting SOUND TEST displays the following screen on the monitor.

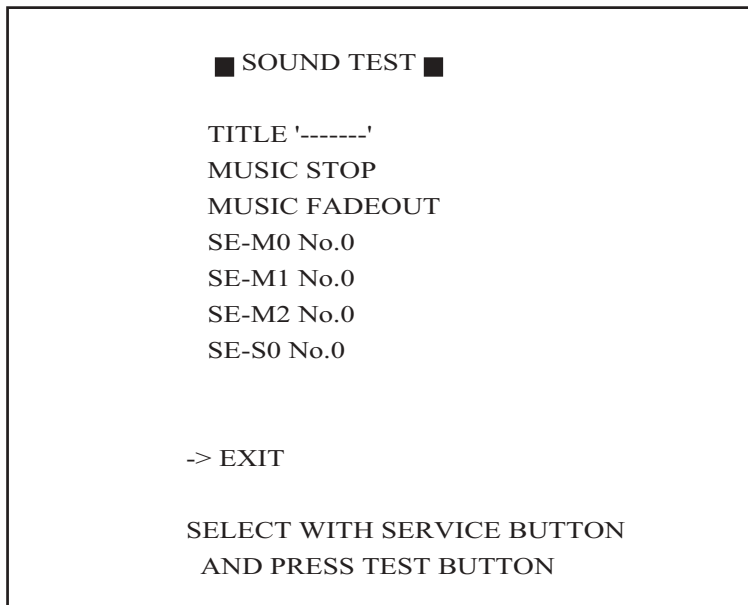

Bring the arrow (->) to TITLE and press TEST Button to emit each sound. To stop the sound, select "MUSIC STOP / MUSIC FADE OUT." Bring the arrow (->) to SE and press TEST Button to have play the sound effects.

Select EXIT and press TEST Button to return to the GAME TEST MODE MENE screen.

## D) GAME ASSIGNMENTS

When GAME ASSIGNMENTS is selected, the following menu screen appears on the monitor.

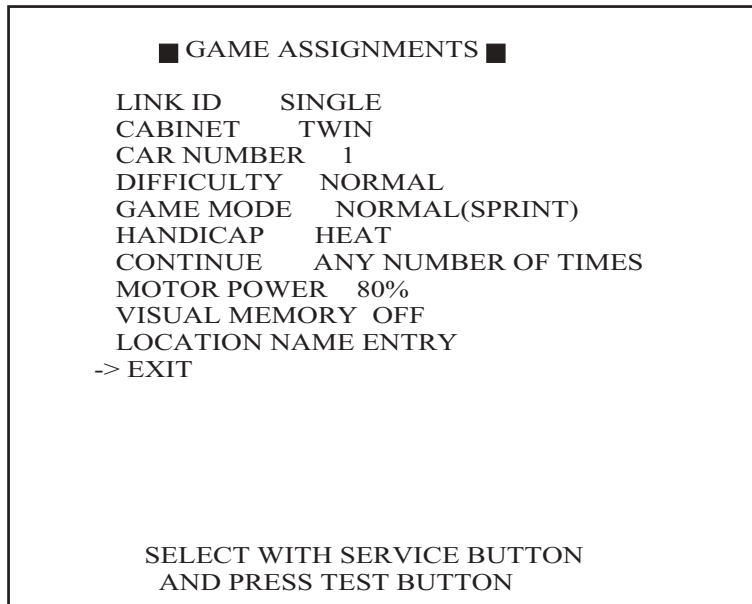

- LINK ID : Communication play setting. Set to either SINGLE, MASTER, or SLAVE. When operating the machines independently, set to SINGLE. For communication play, one of the linked seats needs to be set to MASTER. Set all other seats to SLAVE.
- CABINET : Set to TWIN.
- CAR NUMBER : Car Number setting. Set the Car Numbers sequentially to 1, 2, 3, 4 starting from the leftmost machine, when facing the monitor.
- DIFFICULTY : Time Difficulty Setting. Select from among EASY, NORMAL, HARD, and HARDEST.
- GAME MODE : Laps setting. The standard type of NORMAL (SPRINT) or GRAND PRIX can be selected. Note that GRAND PRIX is for some sorts of special events and therefore not appropriate for a normal operation as it makes the game last a long time.
- HANDICAP : Communication condition setting. Select from among HEAT, AID, or PRO. Normal setting is HEAT.
- CONTINUE : Sets if the game can be continued. Sets the number of laps if continued.  
OFF: No continue.  
ONLY ONCE: 1 lap.  
ANY NUMBER OF TIMES: Unlimited.  
Normal setting is ANY NUMBER OF TIMES.
- MOTOR POWER : Sets the feedback stiffness of the STEERING WHEEL. Select from among 60%, 80%, 90%, and 100%. Standard setting is 80%.
- VISUAL MEMORY : Set to OFF.
- LOCATION  
NAME ENTRY : Location name setting. Outputs the Location Name set in the Visual Memory.
- EXIT : Select EXIT to return to the GAME TEST MENU mode.

## E) BOOKKEEPING

Selecting BOOKKEEPING causes the following to be displayed on the monitor.

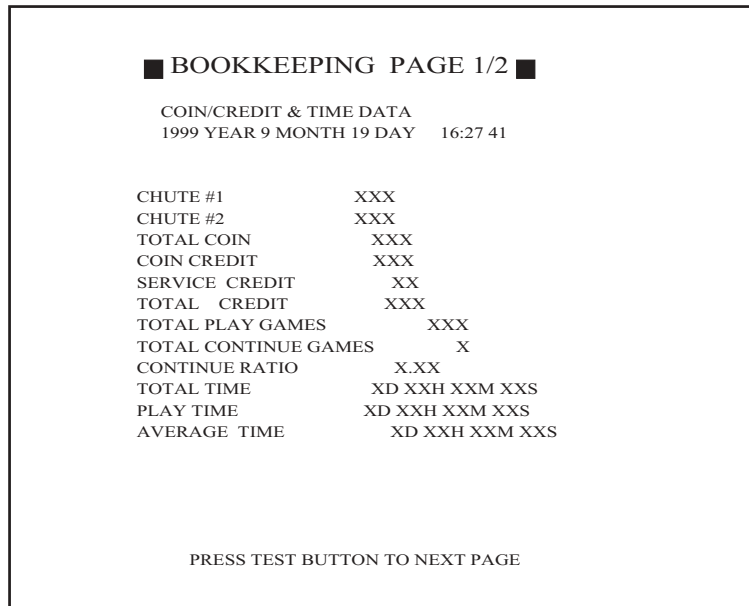

- CHUTE #X: Total number of coins put in.
- TOTAL COIN: Total number of coins inserted.
- COIN CREDIT: Number of credits registered by inserting coins.
- SERVICE CREDIT: Total number of credits given by Service Button.
- TOTAL CREDIT: Total number of credits.
- TOTAL PLAY GAMES: Total number of plays.
- TOTAL CONTINUE GAMES: Total number of continue.
- CONTINUE RATIO: Displays the ratio of Total Continue Game to Total Play Games.
- TOTAL TIME: The total energized time.
- PLAY TIME: Total play time.
- AVERAGE TIME: Displays the average play time.

Press TEST Button to display the play time list in each course on the monitor.

■ BOOKKEEPING PAGE 2/2 ■							
PLAY TIME HISTOGRAM							
1999 YEAR 9 MONTH 19 DAY 16:38 20							
COURSE	MOTEGI	SUZU	SH	MONZA	SUGO	SUZUKA LG	LONGBEACH
UNDER 1M29S	22	0	3	0	0	0	0
1M30S-1M59S	1	0	2	0	0	0	0
2M00S-2M29S	1	0	0	0	0	0	0
2M30S-2M59S	2	0	0	0	0	0	0
3M00S-3M29S	0	1	1	0	0	0	0
3M30S-3M59S	0	0	1	0	0	0	0
4M00S-4M29S	0	0	3	0	0	0	0
4M30S-4M59S	0	0	0	0	0	0	0
5M00S-5M29S	0	0	0	0	0	0	0
5M30S-5M59S	0	0	0	0	0	0	0
6M00S-6M29S	0	0	0	0	0	0	0
6M30S-6M59S	0	0	0	0	0	0	0
7M00S-7M29S	0	0	0	0	0	0	0
OVER 7M30S	0	0	0	0	0	0	0

■ PRESS TEST BUTTON TO EXIT ■

Press TEST Button to return to the GAME TEST MODE MENU.

#### F) F355 BACKUP DATA CLEAR

Selecting F355 BACKUP DATA CLEAR displays the following screen on the monitor.

■ F355 BACKUP DATA CLEAR ■	
YES(CLEAR)	
-> NO(CANCEL)	
SELECT WITH SERVICE BUTTON	
AND PRESS TEST BUTTON	

Select YES (CLEAR) to clear the contents of BOOKKEEPING that can not be cleared by BACKUP DATA CLEAR in the SYSTEM Mode, the ranking, and the name entry data. Selecting and executing YES causes the aforementioned data to be cleared. When the data has been cleared, COMPLETED will be displayed. Press TEST Button after the COMPLETED is disappeared, and the screen returns to the GAME TEST MODE MENU. Bring the arrow to NO (CANCEL) and press TEST Button to return to the MENU mode without clearing the data.

## 10. CONTROL PANEL (HANDLE MECHA)



- Before starting to work, ensure that the Power SW is OFF. Failure to observe this can cause electric shock or short circuit.
- Use care so as not to damage wirings. Damaged wiring can cause electric shock or short circuit.
- Do not touch undesignated places. Touching places not designated can cause electric shock or short circuit.
- This work should be performed by the Location's Maintenance Man or Serviceman. Performing work by non-technical personnel can cause electric shock hazard.
- This unit is a heavy item weighing approximately 22kg. and therefore, be very careful when performing the work. Use plural workers.
- Immediately after the game is finished, the motor may still be very hot. When performing the removal work, wait until the motor cools off.



When securing the Control Panel, be careful so as not to get your fingers or hands pinched in.

In cases the Steering operability is poor and the adjustment of VOLUME SETTING in the TEST mode has no effect, the causes may be the volume gear's mesh failure and or volume malfunctioning. Adjust volume gear mesh or replace the volume as per the following procedure. In this product, when the steering wheel is moved fully left/right, if the volume shaft is rotating within the movable range, the volume is not feared to be damaged. Secure the volume in the manner the volume shaft is oriented as shown and the gears are appropriately engaged when the steering wheel is in the centering position allowing the car to go straight forward.

### 10 - 1 REMOVING THE CONTROL PANEL

- ① Turn the power switch off.
- ② Remove a total of 4 Tamperproof Screws from both sides of the Control Panel's front part.
- ③ Remove the 2 Tamperproof Screws from the underside of the Control Panel.
- ④ Wiring Connectors are connected inside the Control Panel. Carefully draw the Control Panel in the manner not to damage the wiring.
- ⑤ Disconnect the wiring connector.

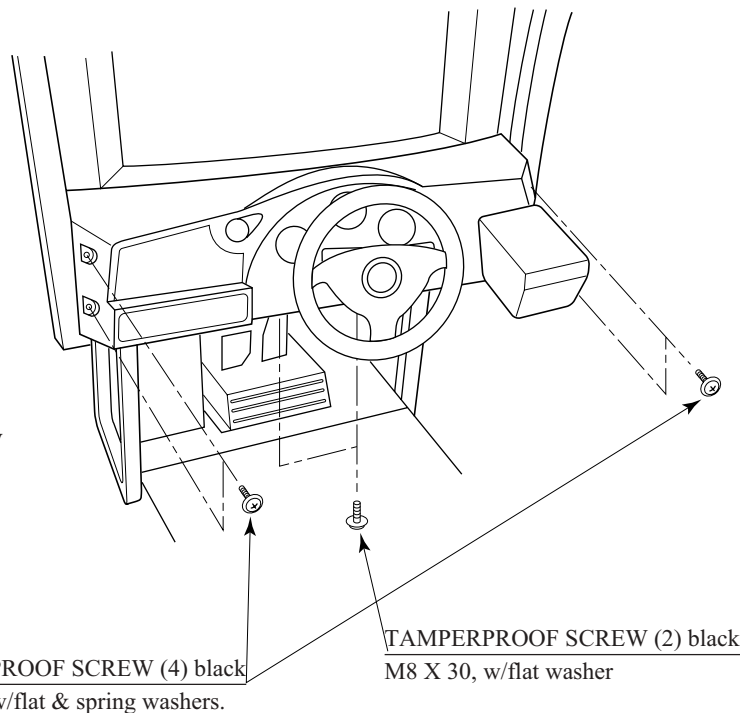

FIG. 10. 1

## 10 - 2 ADJUSTING AND REPLACING THE HANDLE's (STEERING WHEEL's) V.R.



**IMPORTANT!**

After the replacement or adjustment of Volume (V. R.), be sure to set the centering value of Steering Wheel's V.R. in the Test Mode.

### ADJUSTING THE VOLUME

- ① Loosen the 2 screws which secure the Volume Bracket to disengage gear mesh.
- ② With the Steering Wheel in the centering position, cause gears to be engaged in the manner so that the Volume Shaft is in the status shown as per FIG. 10.2.
- ③ Fasten the screws which secure the Volume Bracket.
- ④ Perform Volume setting as per the Volume Setting mode.

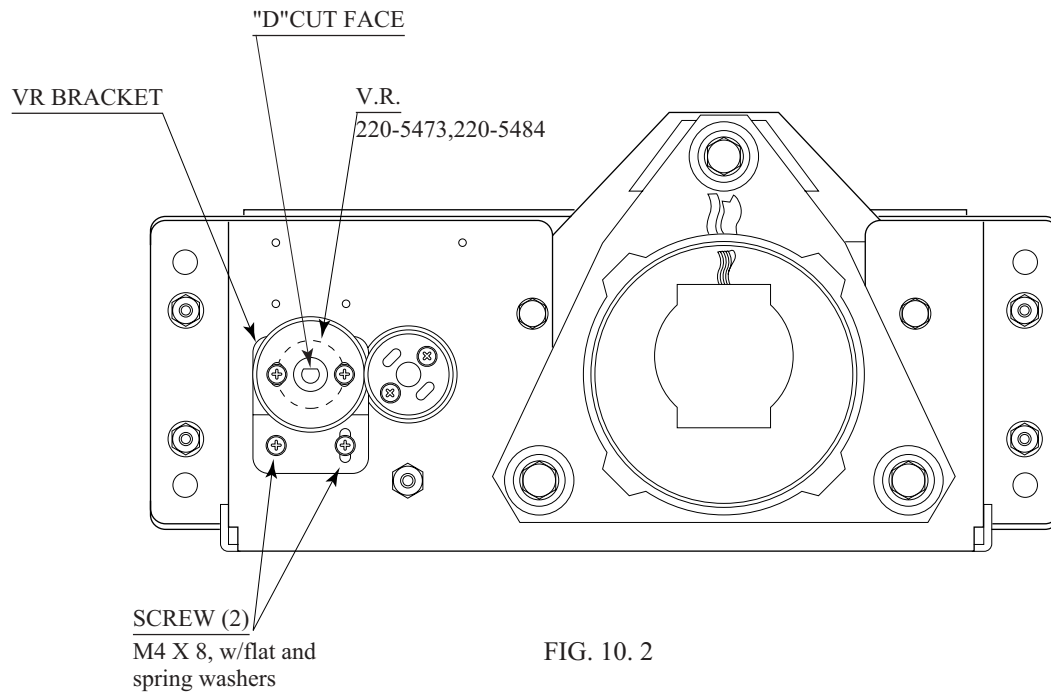

FIG. 10. 2

### REPLACING THE VOLUME

- ① Take out the 2 screws which secure the VOLUME BRACKET and remove the VOLUME BRACKET.
- ② Take out the 2 screws to remove the volume gear and replace the volume.
- ③ After replacing the volume, perform volume setting in the volume setting mode.



## 10 - 3 GREASING



- Be sure to use the designated grease. Using undesignated grease can cause parts damage.
- Do not apply greasing to undesignated places. Failure to observe this can cause malfunctioning or quality deterioration of parts.

Apply greasing to gear mesh portions once every 3 months.  
Use GREASE MATE (SEGA PART NO. 090-0066).

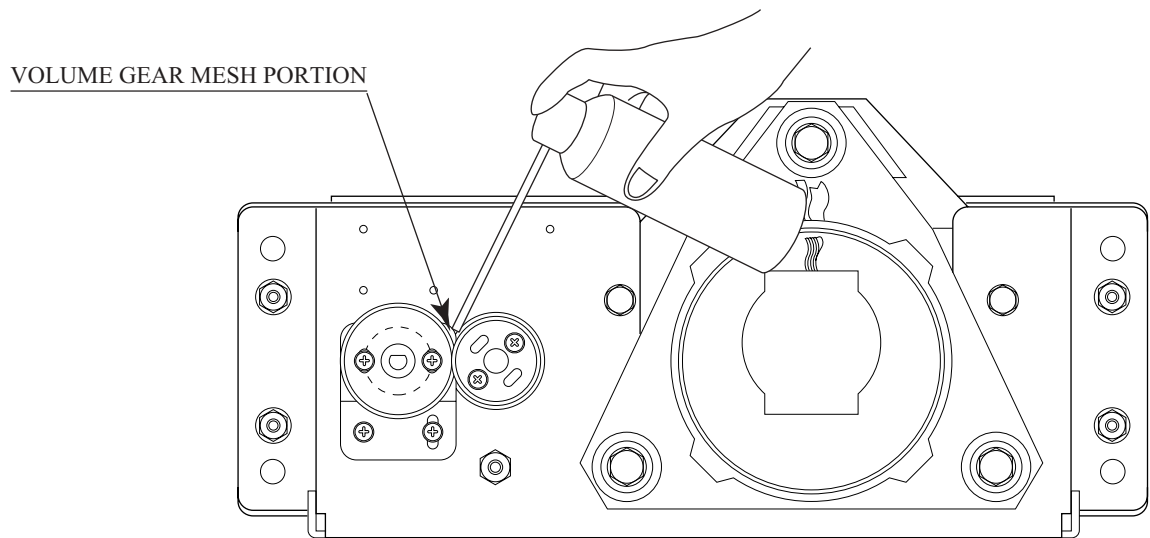

FIG. 10. 3

## 11. ACCELERATOR & BRAKE



WARNING!

- Before starting to work, ensure that the Power SW is OFF. Failure to observe this can cause electric shock or short circuit.
- Use care so as not to damage wirings. Damaged wiring can cause electric shock or short circuit.
- Do not touch undesignated places. Touching places not designated can cause electric shock or short circuit.
- This work should be performed by the Location's Maintenance Man or Serviceman. Performing work by non-technical personnel can cause electric shock hazard.
- When performing work such as parts replacement other than those specified in this manual, be sure to contact where you purchased the product from. Confirm the work procedures and obtain precautions from where you purchased the product prior to performing work. Inappropriate parts replacement and/or installation with erroneous adjustment can cause an overload or the parts to come into contact, resulting in an electric shock, a short circuit, and a fire.



IMPORTANT!

Be sure to perform volume's move value setting in the Volume Setting in the Test Mode after replacing or adjusting the Volume.

If Accel. and Brake operation is not satisfactory, adjustment of volume installation position or volume replacement is needed. Also, be sure to apply greasing to the gear mesh portion once every 3 months.

### 11 - 1 ADJUSTING OR REPLACING THE VOLUME

The appropriate value for both ACCEL. Volume and Brake Volume is under 30H when released and over C0H when stepped on. Check Volume values in the TEST mode. Since work is performed inside the energized cabinet, be very careful so as not to touch undesignated places. Touching places not specified can cause electric shock or short circuit.

- ① Take out the 2 truss screws and remove the Front Cover from the Accel. & Brake Unit (FIG. 11. 1 a).

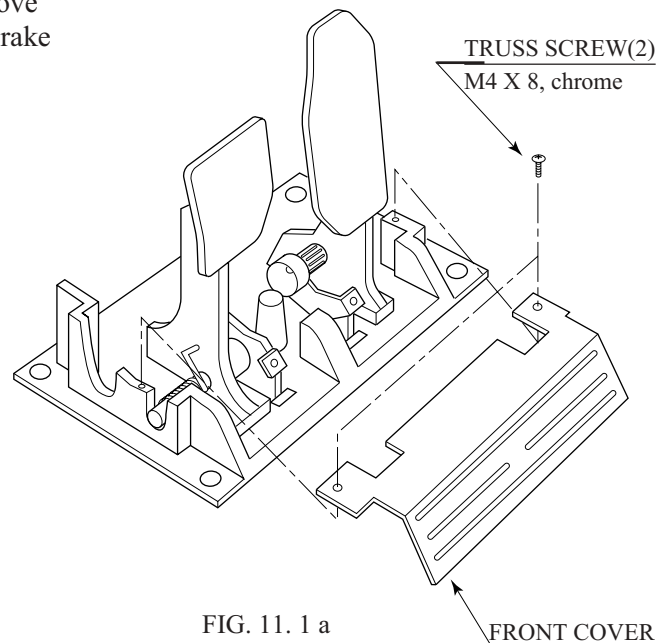

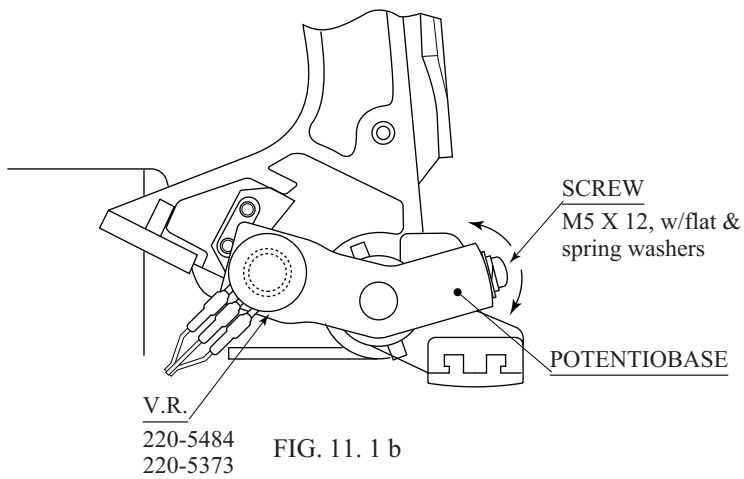

- ② Loosen the screw which secure the Potentiobase, and adjust the Volume value by moving the Base. (FIG. 11. 1 b)
- ③ Secure the Potentiobase.
- ④ Perform volume setting in the volume setting mode.

**REPLACING THE VOLUME**

- ① Turn the power off.
- ② Take out the 2 screws and remove the Potentiocover (FIG. 11. 1 c).
- ③ Disconnect the connector of the volume to be replaced.
- ④ Remove the screw which secures the Potentiobase (FIG. 11. 1 b).
- ⑤ Remove the Potentiobase together with the volume as is attached. (FIG. 11. 1 c)
- ⑥ Remove the base and the gear to replace the volume.
- ⑦ Adjust the volume as per the previous page after replacing.

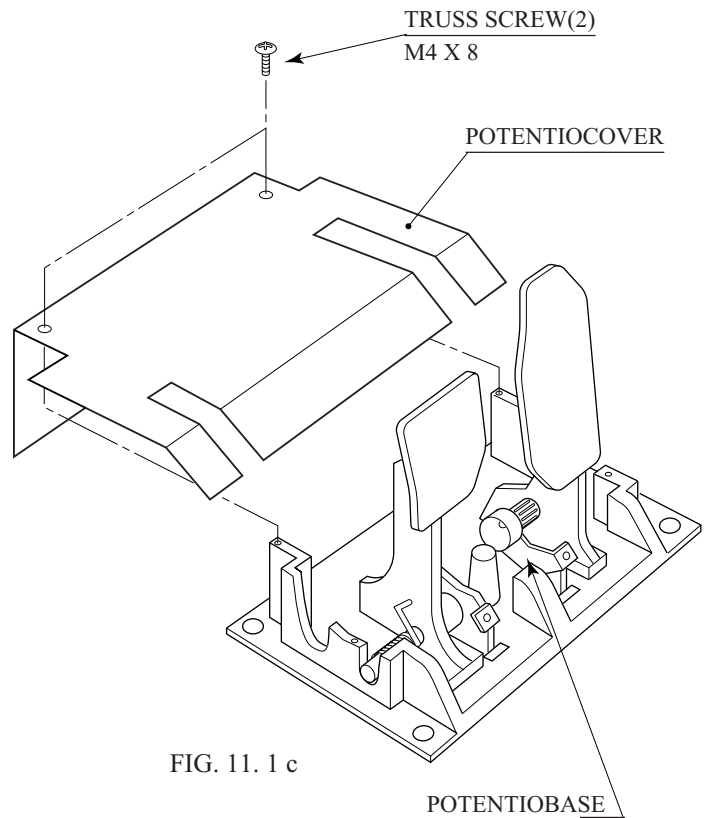

**11 - 2 GREASING**



Be sure to use the designated grease. Using undesignated grease can cause parts damage.

Once every 3 months, apply greasing to the Spring and gear mesh portion. For spray greasing, use GREASE MATE (PART No. 090-0066).

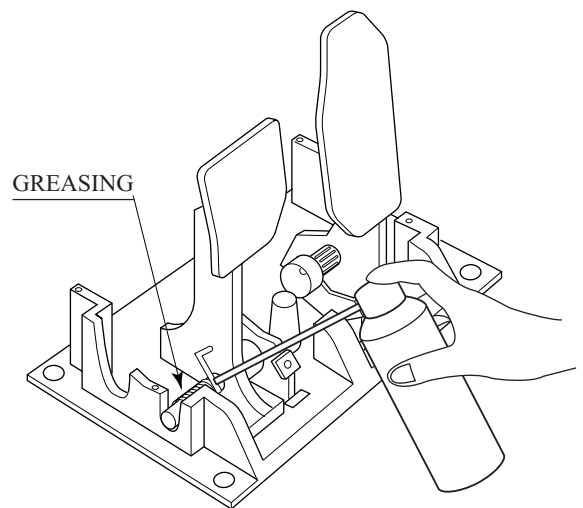

FIG. 11. 2

## 12. PADDLE (WING) SHIFT



- Before starting to work, ensure that the Power SW is OFF. Failure to observe this can cause electric shock or short circuit.
- Use care so as not to damage wirings. Damaged wiring can cause electric shock or short circuit.
- Do not touch undesignated places. Touching places not designated can cause electric shock or short circuit.
- This work should be performed by the Location's Maintenance Man or Serviceman. Performing work by non-technical personnel can cause electric shock hazard.
- When performing work such as parts replacement other than those specified in this manual, be sure to contact where you purchased the product from. Confirm the work procedures and obtain precautions from where you purchased the product prior to performing work. Inappropriate parts replacement and/or installation with erroneous adjustment can cause an overload or the parts to come into contact, resulting in an electric shock, a short circuit, and a fire.

### SWITCH REPLACEMENT

In case the Paddle Shift operability is poor, malfunctioning of or a damage to the Microswitch inside the Paddle Shift can be considered.

- ① Turn off power.
- ② Take out 4 Truss screws for each to remove Boss Cover Upper and Lower.
- ③ Disconnect the wiring connected to the Microswitch.

TRUSS SCREW (4 each)  
M4 X 8

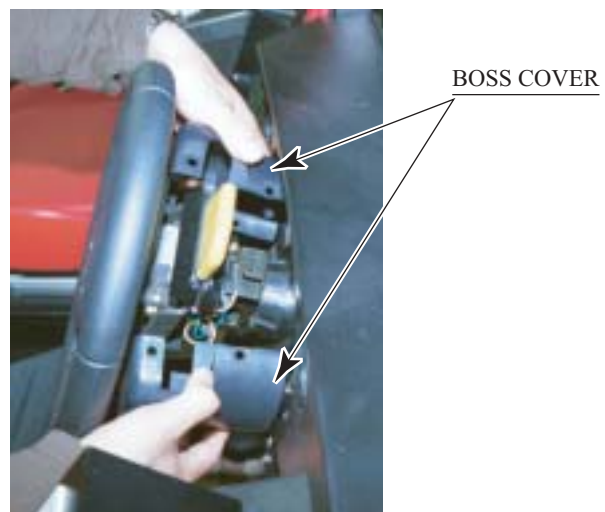
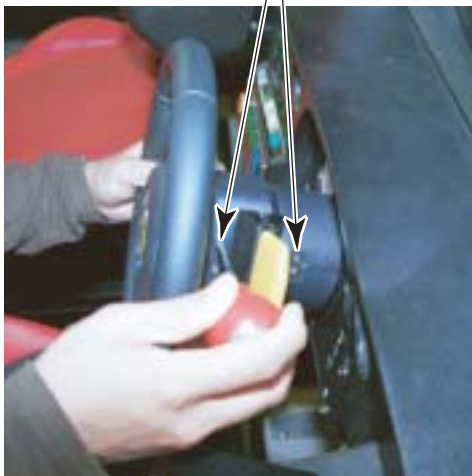

PHOTO 12 a

- ④ Take out 2 screws to replace the Microswitch.
- ⑤ Adjust Microswitch's actuator to an angular position so as not to touch the Switch when operating the Shift Lever.
- ⑥ Fasten 2 screws to secure the Microswitch.
- ⑦ Check to ensure that the Switch goes ON and OFF in consistency with the operation.

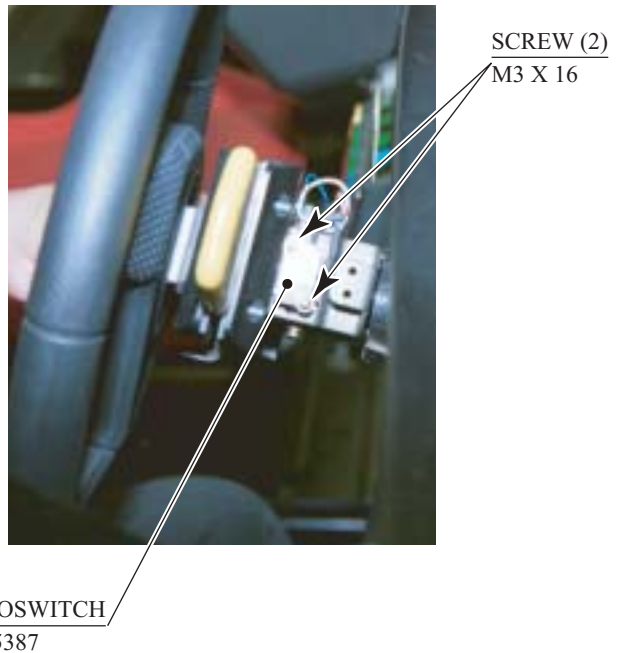

PHOTO 12 b





Tom Happ  
 tom.happ@happcontrols.com  
 Happ Controls, 106 Garlisch Drive, Elk Grove, IL 60007  
 Visit our website <http://www.happcontrols.com>

Ph: 847-593-6161 ext. 107  
 Fx: 847-956-2091

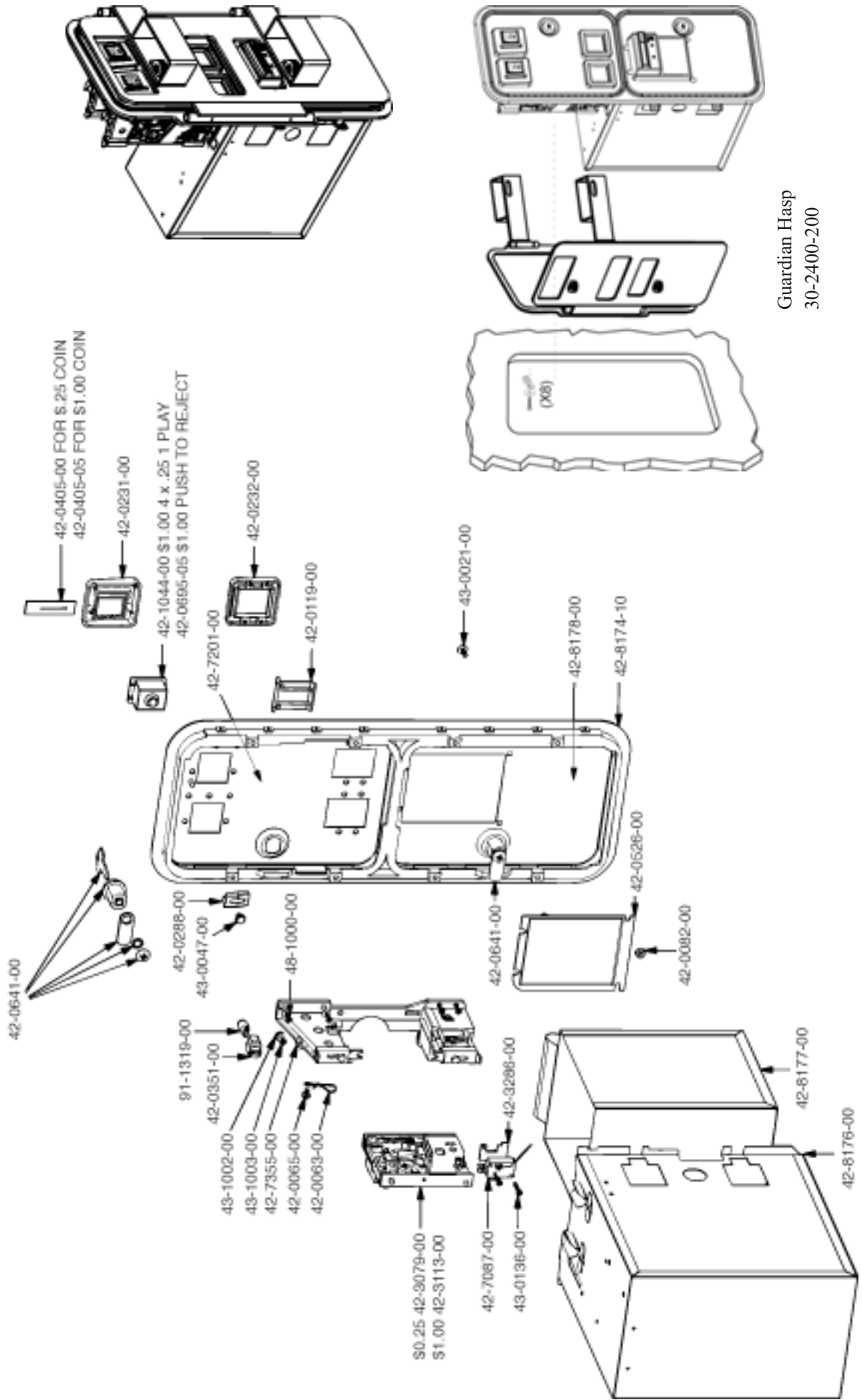

Guardian Hasp  
 30-2400-200



## OPTIONAL DOLLAR BILL ACCEPTOR

- THE COIN DOOR ASSEMBLY USED ON **F355 challenge TWIN TYPE** COMES EQUIPPED TO ACCEPT A DOLLAR BILL ACCEPTOR. ALL NEEDED WIRING CONNECTIONS ARE CONVENIENTLY LOCATED INSIDE THE GAME FOR THIS APPLICATION.
- THE COIN DOOR CAN ACCCOMMODATE THE FOLLOWING VALIDATOR(S):

FORWARD-MOST  
HOLE POSITION

Mars 2000 series

\*\*42-1155-00            MARS VALIDATOR \$1, 2, 5 300 CAP

The frame and cashbox enclosure on this coindoor has been modified to accomodate a Mars 2000 series upstacker. A 2000 series stacker can be added by simply removing the cut-out plate. This one entry door can be ordered through Happ Controls or one of Happ Controls authorized distributors. The part number is 40-6000-10EX. The Mars stacker can be obtained through an atherized Mars distibutor.

Note: Your game may have either Happ Controls Coin Door Assembly or the Wells Gardner Coin Door Assembly (not shown).

\*\*Happ part number

Security Locking Bar/Bracket Set Part No.# 999-0966

Modified Cash Box (For use when DBA installed)  
Part No. # 999-1106

Plastic Cash Box - Full Size Part No. # 999-1177

# 14. MONITOR

## 14 - 1 CAUTIONS AND WARNINGS CONCERNING THE SAFETY FOR HANDLING THE MONITORS

Before handling the monitors, be sure to read the following explanations and comply with the caution/warning instructions given below. Note that the caution/warning symbol marks and letters are used in the instructions.



Indicates that handling the monitors erroneously by disregarding this warning may cause a potentially hazardous situation, which could result in death or serious injury.



Indicates that handling the monitors by disregarding this caution may cause a potentially hazardous situation, which could result in personal injury and or material damage.



Indicates that access to a specific part of the equipment is forbidden.



Indicates the instruction to disconnect a power connector or to unplug.



- When performing such work as installing and removing the monitor, inserting and disconnecting the external connectors to and from monitor interior and the monitor, be sure to disconnect the power connector (plug) before starting the work. Proceeding the work without following this instruction can cause electric shock or malfunctioning.
- Using the monitor by converting it without obtaining a prior permission is not allowed. SEGA shall not be liable for any malfunctioning and accident caused by said conversion.



### Primary side and Secondary side

The monitor's circuit which is divided into the Primary side and Secondary side, is electrically isolated. Do not touch the primary side, or do not touch both the primary side and the secondary side simultaneously. Failing to observe the instruction can cause electric shock and this is very dangerous. When making monitor adjustments, use a non-conductive driver and make adjustment without touching any part other than the Adjustment V. R. and knob. Also, be sure not to cause a short-circuit to the Primary side and Secondary side. If short-circuited, it can cause electric shock or malfunctioning, which is very dangerous.

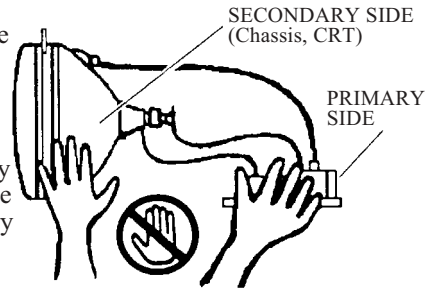

### High-tension Voltage

Some of the parts inside monitor are subject to high-tension voltage in excess of 20,000 volts and very dangerous. Therefore, do not touch the monitor interior. Should soldering & paper wastes, etc. be mixed in the monitor interior, turn the power off so as not to cause malfunctioning or fire hazard.

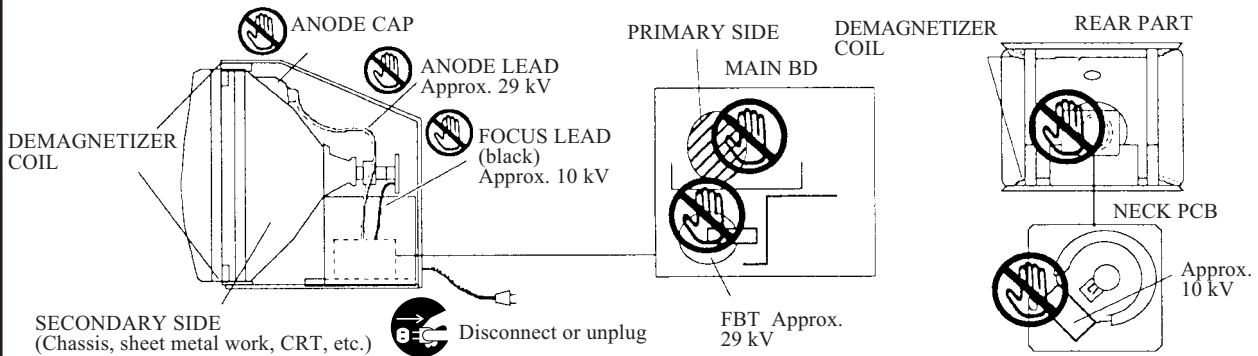

### Connecting the CRT and PCB

For combining the CRT and PCB, use the specified part No. to maintain the status of adjustments made at the factory. The anode of the CRT itself will be accumulatively charged as time elapses, generating high-tension voltage which is very dangerous. The monitor should be used with the Chassis, CRT and PCB assembled. When repair, etc. is required at the time of malfunctioning, be sure to send it in an "as is assembled" condition. If these are disassembled, what's charged to said high tension voltage can be discharged, causing a very hazardous situation. Therefore, under no circumstances should it be disassembled.



**CAUTION!**

- **Static Electricity**

Touching the CRT surface sometimes causes you to slightly feel electricity. This is because the CRT surfaces are subject to static and will not adversely affect the human body.

- **Installation and removal**

Ensure that the Magnetizer Coil, FBT (Fly-Back Transformer), Anode Lead and Focus Lead are not positioned close to the sheet metal work's sharp edges, etc. and avoid damaging the insulated portions so as not to cause electric shock and malfunctioning. (For the name of parts, refer to the above Figures).



For the purpose of static prevention, special coating is applied to the CRT face of this product. To protect the coating, pay attention to the following points. Damaging the coating film can cause electric shock to the customers.

- Do not apply or rub with a hard item (a rod with pointed edge, pen, etc.) to or on the CRT surfaces.
- Avoid applying stickers, seals, etc. on the CRT face.
- Do not remove aluminum foils from the CRT corners. Removing the aluminum foils can cause static prevention effects to be lowered.

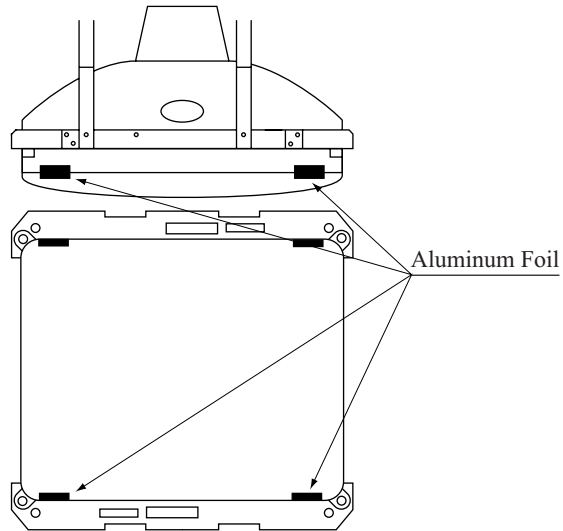

#### 14 - 2 CAUTIONS TO BE HEDED WHEN CLEANING THE CRT SURFACES



Static preventive coating is applied to the CRT surfaces. When cleaning, pay attention to the following points. Peeling off of static preventive coat can cause electric shock.

- Remove smears by using a dry, soft cloth (flannels, etc.). Do not use a coarse gauze, etc.
- For smear removing solvent, alcohol (ethanol) is recommended. When using chemical detergent, be sure to follow instructions below:
  - Dilute chemical detergent with water and dip a soft cloth in and then thoroughly wring it to wipe smears off.
  - Do not use a chemical detergent containing an abradant, powder or bleaching agent.
  - Do not use alkaline chemical detergents such as "glass cleaner" available on the market or solvents such as thinner, etc.
- Do not rub or scratch the CRT face with hard items such as brushes, scrub brush, etc.

Clean the CRT surfaces once a week. When cleaning, pay attention to the above caution so that the antistatic coating will not come off.

### 14 - 3 ADJUSTMENT METHOD



- Monitor adjustments have been made at the time of shipment. Therefore, do not make further adjustment without a justifiable reason. Adjusting the monitor which contains high tension parts is a dangerous work. Also, an erroneous adjustment can cause deviated synchronization and image fault, resulting in malfunctioning.
- When making adjustment, utilize a resinous Alignment Rod. Servicing with bare hand or using conductive tools can cause electric shock.

To make monitor adjustment, take off the 2 Truss Screws from CRT ADJUST PANEL portion. The Adjustment BD appears when the screws are removed.

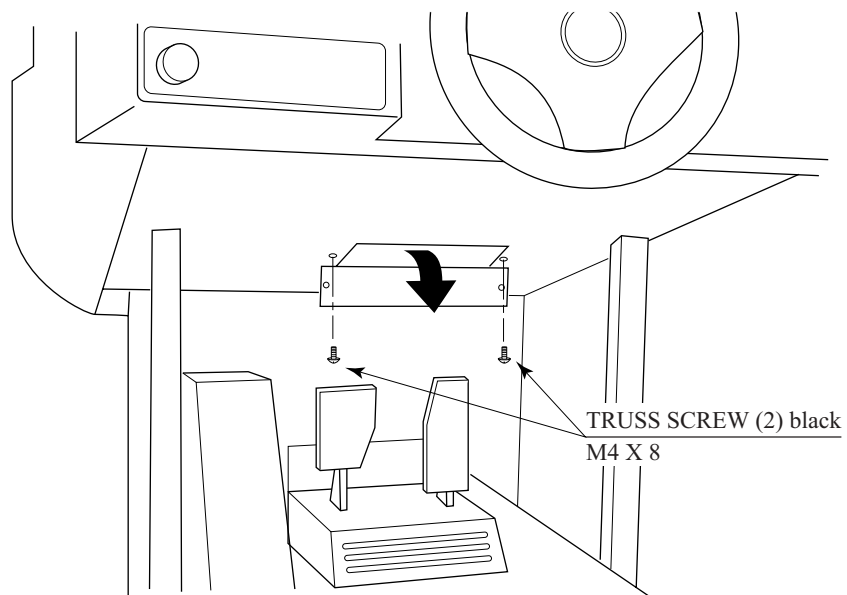
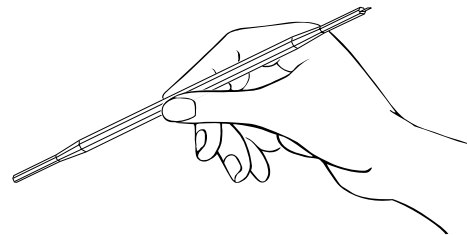

FIG. 14. 3 a



For adjustment, use the Resinous Adjustment Rod.

FIG. 14. 3 b

NANAO monitor:

(24K mode)

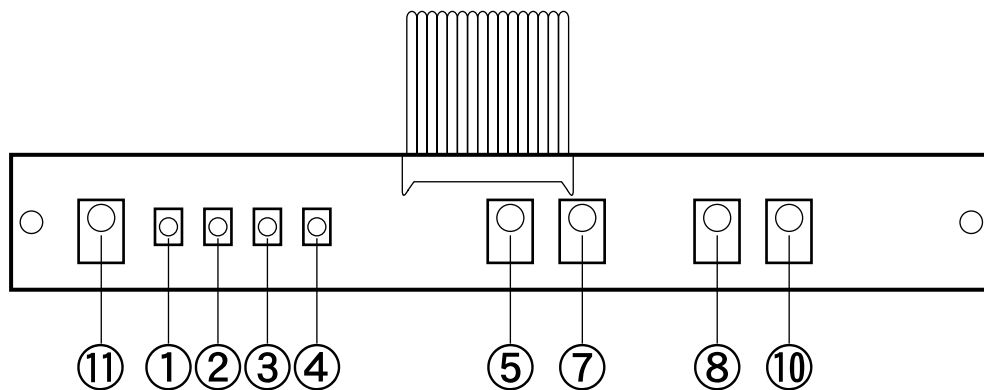

- ① R-GAIN .....
- ② G-GAIN ..... Controls colors.
- ③ B-GAIN .....
- ④ BRIGHT ..... Controls screen brightness.
- ⑤ H. SIZE ..... Controls horizontal screen size.
- ⑦ H. POSI ..... Controls horizontal display position on screen.
- ⑧ V. SIZE ..... Controls vertical screen size.
- ⑩ V. POSI ..... Controls vertical display position on screen.
- ⑪ CONTRAST .... Adjusts image contrast.

## 15. REPLACING THE FLUORESCENT LAMP



- When performing work, be sure to turn power off. Working with power on can cause electric shock and short circuit hazards.
- The Fluorescent Lamp, when it gets hot, can cause burn. Be very careful when replacing the Fluorescent Lamp.
- Be sure to use lamps of the designated rating. Using lamps of undesignated rating can cause a fire or malfunctioning.



To perform work safely and securely, be sure to prepare a step which is in a secure and stable condition. Performing work without using the step can cause violent falling down accidents.

### FLUORESCENT LAMP

- ① Turn off power.
- ② Take out 3 truss screws to open the BILLBOARD LID, and the fluorescent lamp can be replaced.

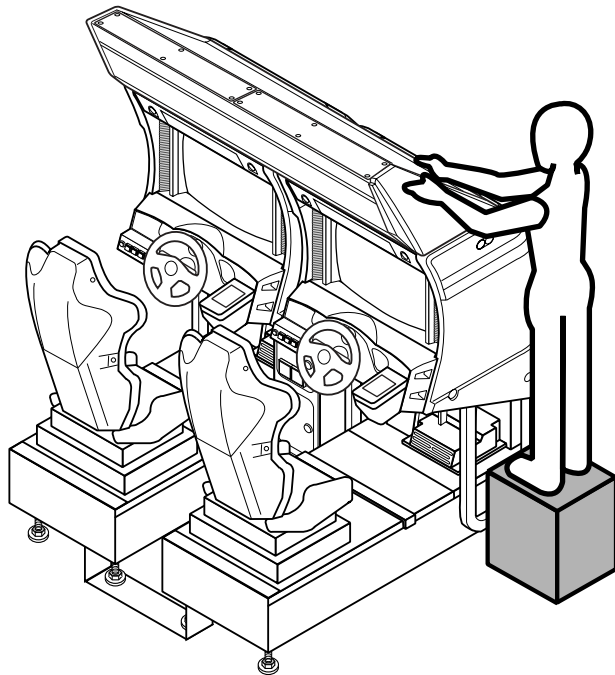

When performing work,  
be sure to use a step.

FLUORESCENT LAMP 40W: 390-5251-40-01  
GLOW BULB: 390-5638-4P

TRUSS SCREW (3) black  
M4 X 8

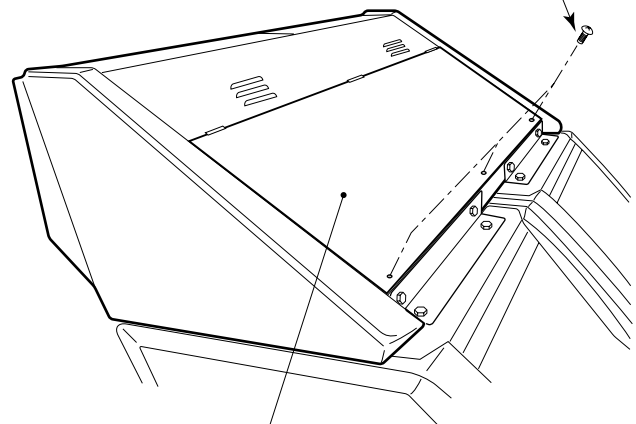

BILLBOARD LID

FIG. 15 a

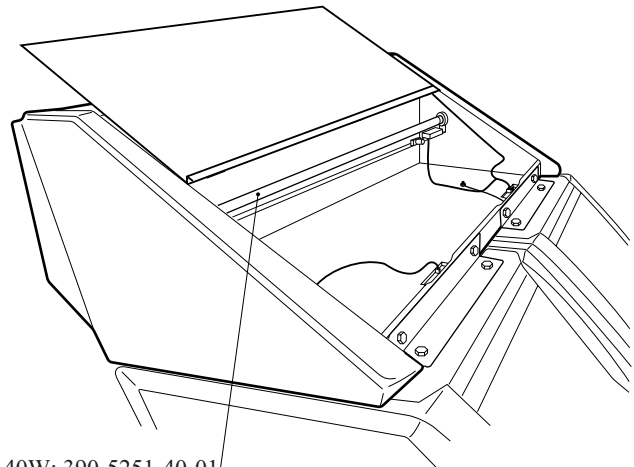

FIG. 15 b

## CATHODE TUBE

- ① Take off the 6 truss screws to remove the UPPER LID.
- ② Take off the 2 flange nuts and 2 screws to remove the HOLDER PLATE B. The same can be applied to the HOLDER PLATE A.
- ③ Remove the HOLDER PLATE, and the CATHODE TUBE appears. Disconnect the connector to remove the CATHODE TUBE.

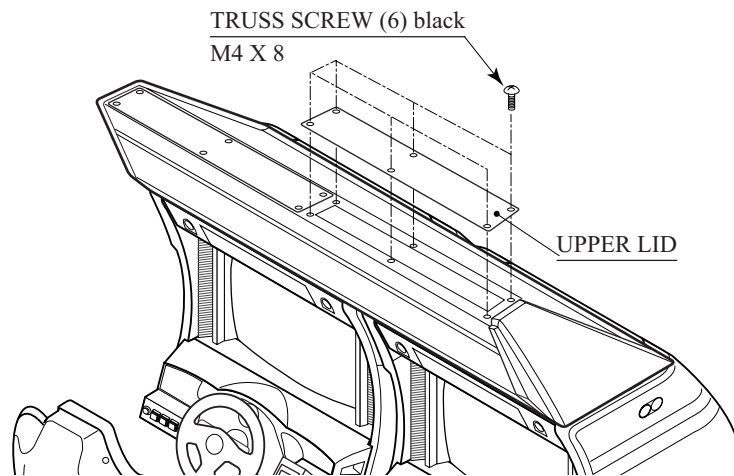

FIG. 15 c

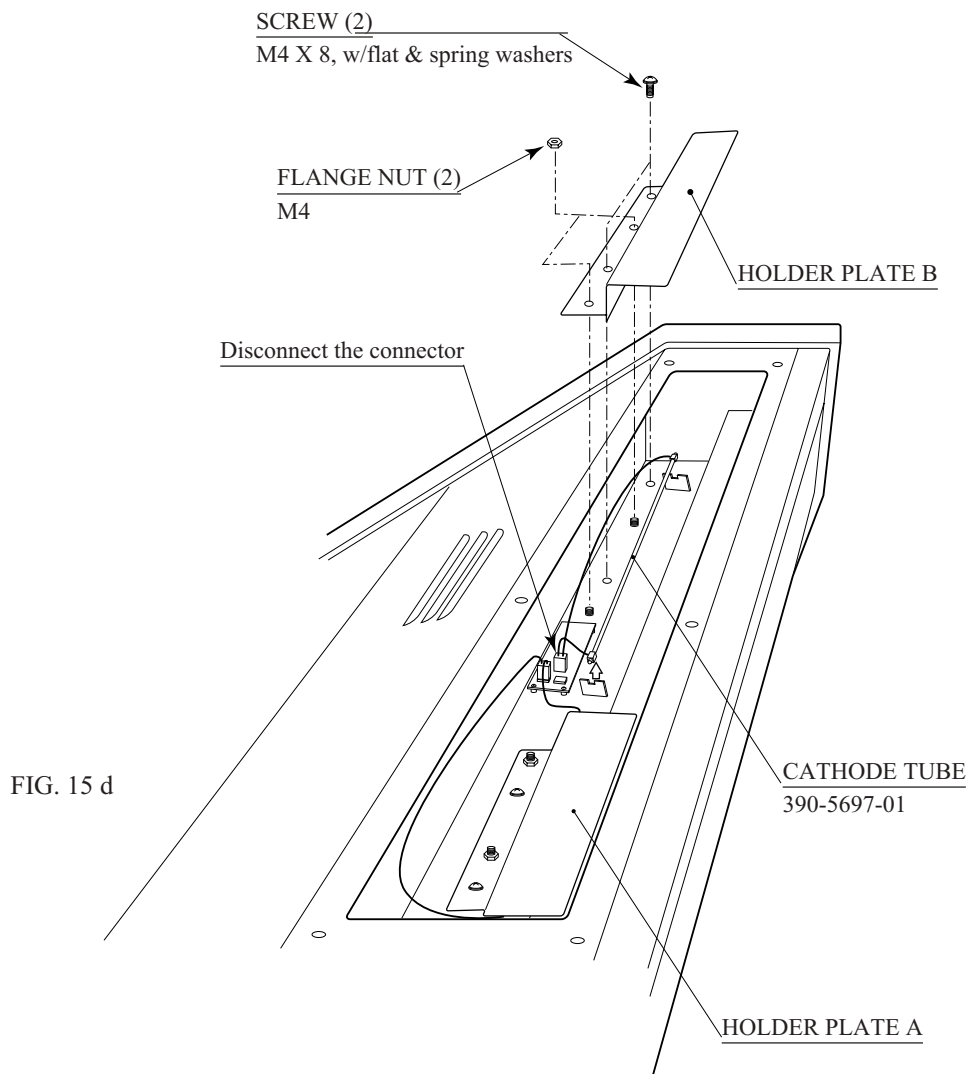

FIG. 15 d



## 16. PERIODIC INSPECTION TABLE

The items listed below require periodic check and maintenance to retain the performance of this machine and to ensure safe business operation.



- Be sure to check once a year to see if Power Cords are damaged, the plug is securely inserted, dust is accumulated between the Socket Outlet and the Power Plug, etc. Using the product with dust as is accumulated can cause fire and electric shock hazards.
- Periodically once a year, request the place of contact herein stated or the Distributor, etc. where the product was purchased from, as regards the internal cleaning. Using the product with dust as is accumulated in the interior without cleaning can cause a fire or accident. Note that cleaning the interior parts can be performed on a pay-basis.

TABLE 16

	Item	Interval	Reference
CABINET	Check Adjusters' contact with surface.	Daily	3
HANDLE MECHA	Check lamps.	Monthly	9
	Check VOLUME VALUE.	Monthly	9, 10-2
	Check ADJUST GEAR engagement.	Trimonthly	10-2
	Greasing of GEAR.	Trimonthly	10-3
ACCEL. & BRAKE	Check VOLUME value.	Monthly	9,11-1
	Check ADJUST GEAR engagement.	Trimonthly	11-1
	Gear and Spring portion greasing.	Trimonthly	11-2
PADDLE SHIFT	Check switches.	Monthly	9,12
COIN CHUTE TOWER	Check COIN SW.	Monthly	9
	Coin insertion test.	Monthly	13
	Cleaning of COIN SELECTOR.	Trimonthly	13
MONITOR	Check adjustments.	Monthly or when moving.	6,9,14
	Cleaning of CRT surfaces.	Weekly	14-2
SEAT	Applying grease to Seat Rail	Trimonthly	Next page (FIG.16)
GAME BD	MEMORY TEST.	Monthly	9
	Check settings.	Monthly	9
Cabinet surfaces	Cleaning	As necessary.	Next page
INTERIOR	Cleaning	Annually	See above.
POWER SUPPLY PLUG	Inspection and cleaning		

### SEAT (Greasing to Seat Rail Portion)

Move the Seat to the rearmost portion and apply spray greasing to the portion shown at the right once every 3 months by using NOK KLUBER L60 or GREASE MATE SEGA PART No. 090-0066.

After greasing, move the Seat a few times forward and backward so as to allow the grease to be applied all over uniformly. Be sure to wipe grease which attaches to the surfaces of the PROTECT RUBBER on the Seat Rail, or any excess grease.

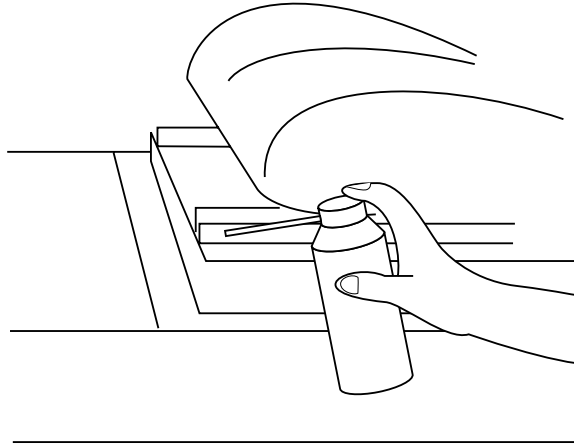

FIG. 16

### CLEANING THE CABINET SURFACES

When the cabinet surfaces are badly soiled, remove stains with a soft cloth dipped in water or diluted (with water) chemical detergent and squeezed dry. To avoid damaging surface finish, do not use such solvents as thinner, benzine, etc. other than ethyl alcohol, or abrasives, bleaching agent and chemical dustcloth.

# 17. TROUBLESHOOTING



- In order to prevent electric shock and short circuit, be sure to turn power off before performing work.
- Be careful so as not to damage wirings. Damaged wiring can cause electric shock or short circuit.
- After removing the cause of the functioning of the Circuit Protector, reinstate the Circuit Protector. Depending on the cause of the functioning, using the Circuit Protector as is without removing the cause can cause generation of heat and fire hazard.

In case a problem occurs, first check wiring connector connections.

TABLE 17 a

PROBLEMS	CAUSE	COUNTERMEASURES
When the main SW is turned ON, the machine is not activated.	The power is not ON.	Firmly insert the plug into the outlet.
	Incorrect power source/voltage.	Make sure that the power supply/voltage are correct.
	AC UNIT CIRCUIT PROTECTOR functioned due to instantaneous overcurrent.	First, remove the cause of overcurrent and reinstate the circuit protector to its original status (refer to Sec. 6).
	The Connect BD Fuse is blown due to momentary overload.	Replace fuse (see PHOTO 17). 514-5036-7000 FUSE 6.4 X 30 7000mA 125V
The color of image on MONITOR screen is incorrect.	Incorrect monitor adjustment.	Make appropriate adjustments (see Sec. 14).
The on-screen image of the monitor sways and or shrinks.	The power source and voltage are not correct.	Make sure that the power supply and voltage are correct.
Sound is not emitted.	Sound volume adjustment is not correct.	Adjust the SWITCH UNIT's sound adjustment volume (control) (see Sec. 9).
	Malfunctioning BD. and Amp.	Perform Sound Test to check it (see Sec. 9).
	Connector connection is incorrect.	Check connector connection from Base to Speaker.

CIRCUIT PROTECTOR

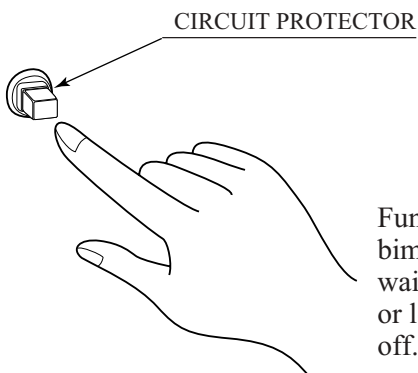

Functions due to the activation of bimetal. To restore the function, wait for approximately one minute or longer until the bimetal cools off. (Press the Button.)

TABLE 17 b

PROBLEMS	CAUSE	COUNTERMEASURES
Steering Wheel reaction strength is incorrect. Deviation of Center.	Power ON check not performed correctly.	Turn off power and then turn it back on again. Complete the power on check.
	V.R. position deviated.	Adjust V. R. value in the test mode (see Sec. 9).
	V.R. malfunctioning.	Replace V.R. (see Sec. 10).
Steering Wheel reaction strength is insufficient.	Reaction Mecha's secular change.	Adjust V. R. value in the Test mode (see Sec. 9).
No Steering Wheel Reaction.	Connector Connection is incorrect.	Check connector connection from Base to Handle.
	The Motor Drive BD fuse is blown due to momentary overload.	Contact where you purchased the product from.
Operation of Accel. and Brake Pedals are not satisfactory.	V.R. position deviated.	Adjust V.R. value in the test mode (see Sec. 9).
	V.R. malfunctioning.	Replace the V.R. (see Sec. 11).
	ADJUST GEAR's engagement is not correct.	Adjust the engagement of ADJUST GEAR (see Sec. 11).
PADDLE SHIFT doesn't operate satisfactorily.	Switch malfunctioning.	Replace the Switch (see Sec. 12).
Fluorescent lamp doesn't light up.	Fluorescent lamp needs replacement.	Replace the fluorescent lamp (see Sec. 15).
	The connector is disconnected.	Check connector connections in the billboard case (see Sec. 6).
Interactive play is not possible.	Cable connections are not correct.	Connect the cable correctly (see Sec. 20).
	Settings for communication play are not correct.	Ensure that GAME ASSIGNMENTS settings in the Test mode are correct (see Sec. 9).
The leader lamp does not light up.	Cathode Tube needs replacement.	Replace the Cathode Tube (see Sec. 15). Part No. 390-5679-01
	The connector is disconnected.	Check connector connections in the billboard case (see Sec. 6).

## REPLACEMENT OF FUSE



- Fuse replacements other than those specified can cause accidents and are strictly forbidden. In case fuse replacements other than those stated in this manual are necessary, contact where you purchased the product from for inquiries regarding this matter.
- In order to prevent an electric shock, be sure to turn power off and unplug from the socket outlet before performing work by touching the internal parts of the product.
- Be careful so as not to damage wirings. Damaged wiring can cause electric shock and short circuit accidents.
- Be sure to use fuses meeting specified rating. Using fuses exceeding the specified rating can cause fire and electric shock accidents.
- After eliminating the cause of the blowing of fuse, replace the fuse. Depending on the cause of fuse blowing, continued use with the fuse as is blown can cause generation of heat and fire hazard.

Incline the Seat and remove Base Lid F to view the Base interior. The composition of the Base interior is as shown below. (See Section 18-1)  
The fuse is provided as shown below. When replacing the fuse, be sure to use the specified one.



FUSE 125V 7A  
514-5036-7000

PHOTO 17

## 18. GAME BOARD



**WARNING!**

- In order to prevent electric shock and short circuit hazards, be sure to turn power off before performing work.
- Be careful so as not to damage wirings. Damaged wiring can cause fire, electric shock and short circuit hazards.
- Do not expose the Game BD, etc. without a good reason. Failure to observe this can cause electric shock hazard or malfunctioning.



**CAUTION!**

In this product, setting changes are made during the test mode. The Game BD need not be operated. Use the Game BD, etc. as is with the same setting made at the time of shipment so as not to cause electric shock and malfunctioning.



**IMPORTANT!**

Put the Game Board in the Carton Box (an accessory) together with the Shield Case when requesting for the replacement or repair. Transporting the Game Board in an undesignated status for replacement/repair is unacceptable.

### 18 - 1 REMOVING THE BOARD

To replace the IC BD (such as Game BD, Drive BD, etc.), take out the IC BD by using the following procedure:

- ① Turn the MAIN SW off.
- ② Take out a truss screw to remove the TOWER BRACKET.

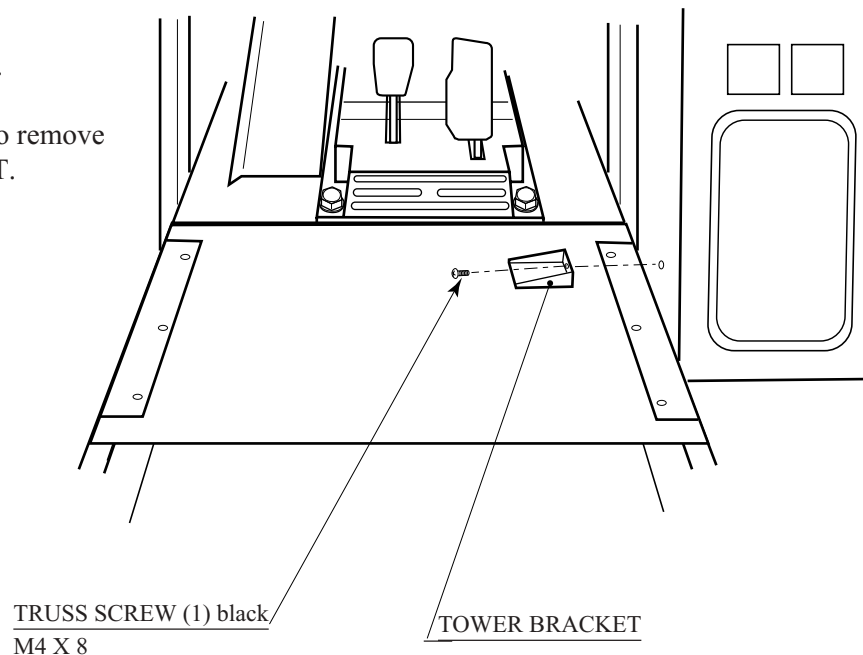

FIG. 18. 1 a



PHOTO 18. 1 Disconnect all connectors

- ③ Unlock and take off the 2 truss screws from the side of the base as shown.
- ④ Turn the knob to unlock. The seat can be inclined in the direction shown. When inclining the seat, be careful so as not to damage the seat parts. Carefully cause the backrest portion of the seat to come into contact with the floor. If the floor has hard surfaces, protect the seat from damage by using a cloth, etc. on the floor surfaces.
- ⑤ Disconnect all connectors from the SHIELD CASE and take off the 4 screws to remove the SHIELD CASE.

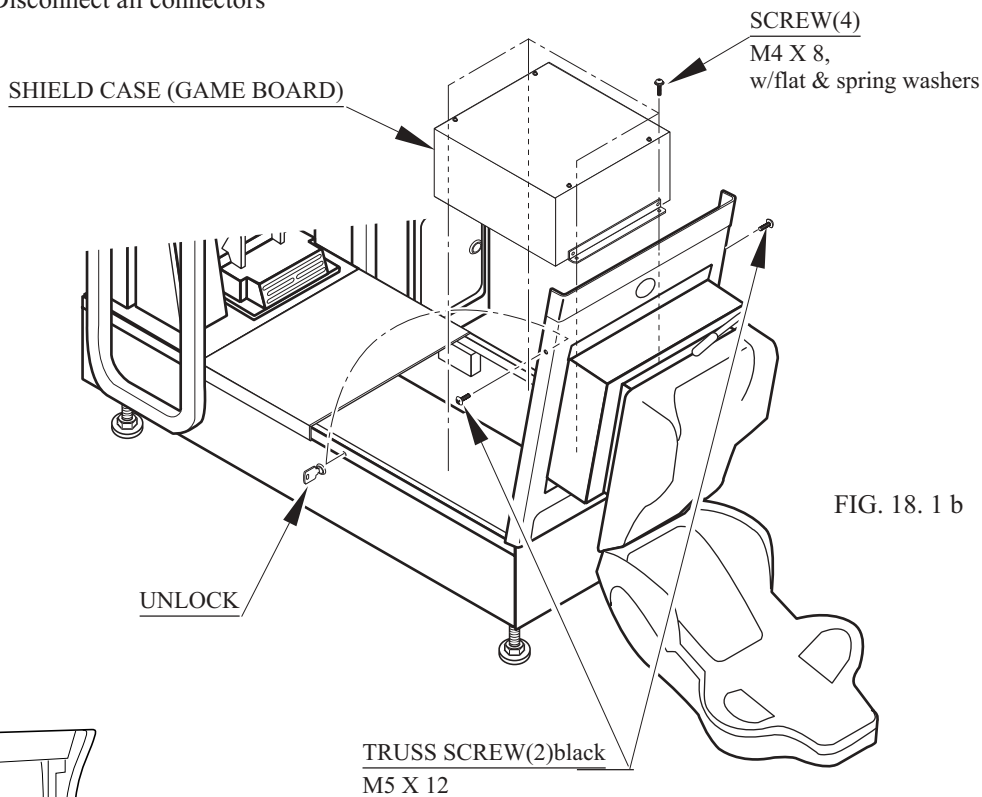

FIG. 18. 1 b

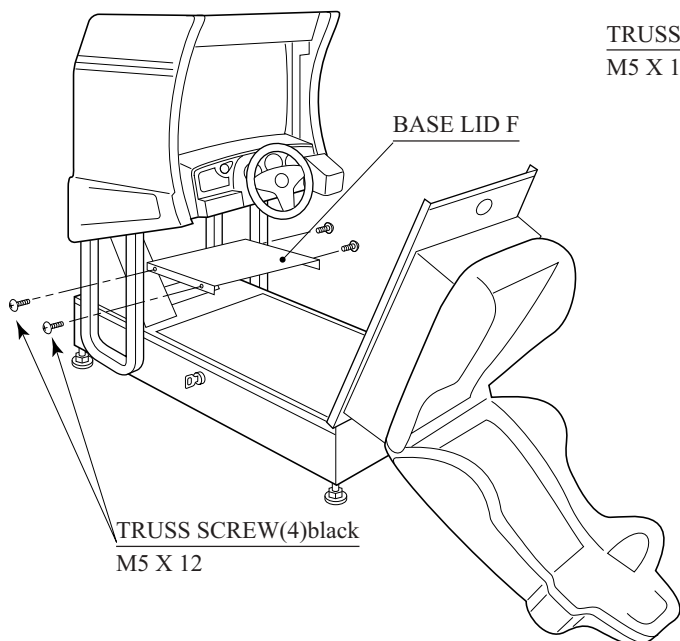

FIG. 18. 1 c

- ⑥ Take off a total of 4 screws from both sides with the seat being in an inclined state and remove BASE LID F. Removing Base Lid F allows ELEC BASE to be viewed.

18 - 2 FILTER BOARD



Ensure that the DIP SW setting is performed as designated. Failure to observe this may cause functioning not suitable for the actual operation, or malfunctioning.

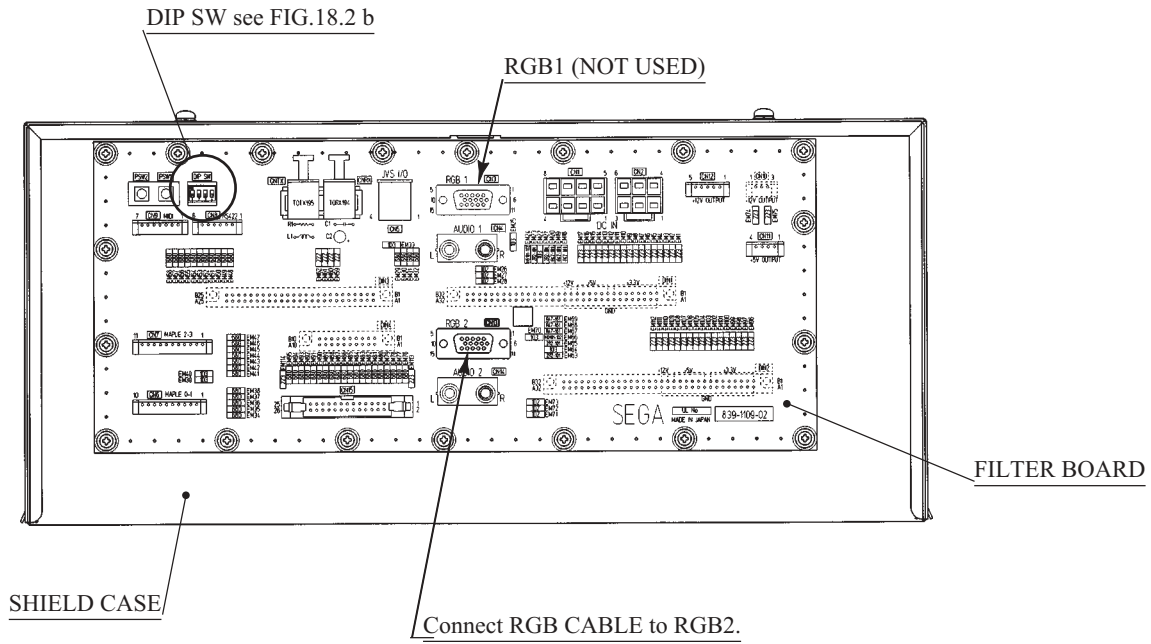

FIG. 18. 2 a

DIP SW SETTING

Set all DIP SW on the FILTER BOARD to OFF.

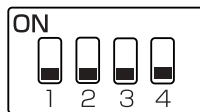

FIG. 18. 2 b



### 18 - 3 ERROR DISPLAY (DRIVE CONTROL BOARD)

- Be careful so as not to damage wirings. Damaged wiring can cause electric shock and short circuit hazards.
- Do not touch undesiganted places. Touching places not specified can cause electric shock and short circuit hazards.

If an irregularity occurs in the Drive Control Board, etc., the ERROR message is shown on the screen and the 7-SEG display on the Drive Control BD. Take countermeasures in the manner corresponding to the ERROR message. Note that even at the time of error occurrence, game play is possible without Steering Wheel reaction.

Among the ERROR display as per Table 18.3, each of Er 01, 02, 20 and 22 is displayed before the Advertise mode is displayed if an irregularity is found during initialization setting movements when power is turned on and at the time the Test Mode is finished.

From among error displays as per Table 18.3, Er 23, 24, and 25 indicate On-Board 7-SEG error display when an irregularity is found during game and ADVERTISE mode. If an irregularity is found during game, game play can be continued without Steering Wheel reaction.

Table 18.3 ERROR DISPLAY

7-SEG display on Drive Control BD.	ERROR	CAUSE/COUNTERMEASURES
Er 01	ROM ERROR	Malfunctioning of Drive Control Board. Replace Drive Control Board.
Er 02	RAM ERROR	
Er 20	Initialization setting irregularity of motor	Irregularity during initialization setting movement. Finish initialization setting movement by turning power off and then on. Note that when ERROR is displayed, the malfunctioning relates to the Motor System (Motor, Drive Control BD which controls the Motor, Drive BD., wirings in between, etc.)
Er 22	Steering Wheel's centering error	Malfunctioning during initial setting movement. Finish initialization setting movement by turning power off and then on. Note that when ERROR is displayed, the malfunctioning relates to the Steering Wheel Volume system.
Er 23	ERROR of the Encoder incorporated in the motor.	Malfunctioning which occurs during operation. First turn the power off and after 10 min., turn it back on again. Note that when this Error is displayed, the malfunctioning relates to the Motor System.
Er 24	Overcurrent ERROR	
Er 25	Overheat Overload	

If Error display is shown on the screen, remove BASE LID F **without turning power off** to check the 7-SEG display on the Drive Control Board. At this time, if the power is turned off, each of Er 23, 24 and 25 which could have occurred during operation may not be displayed.

Perform the DIP SW setting on the DRIVE CONTROL BOARD and the ASSY MAIN BD BASE as shown below.

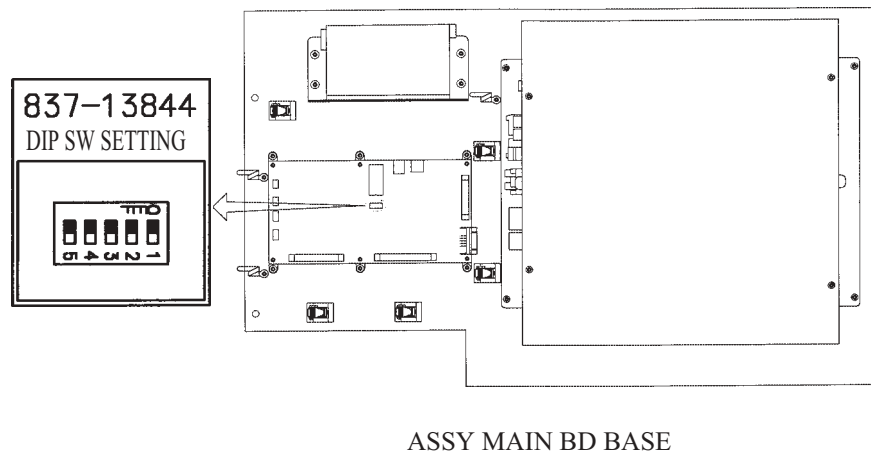
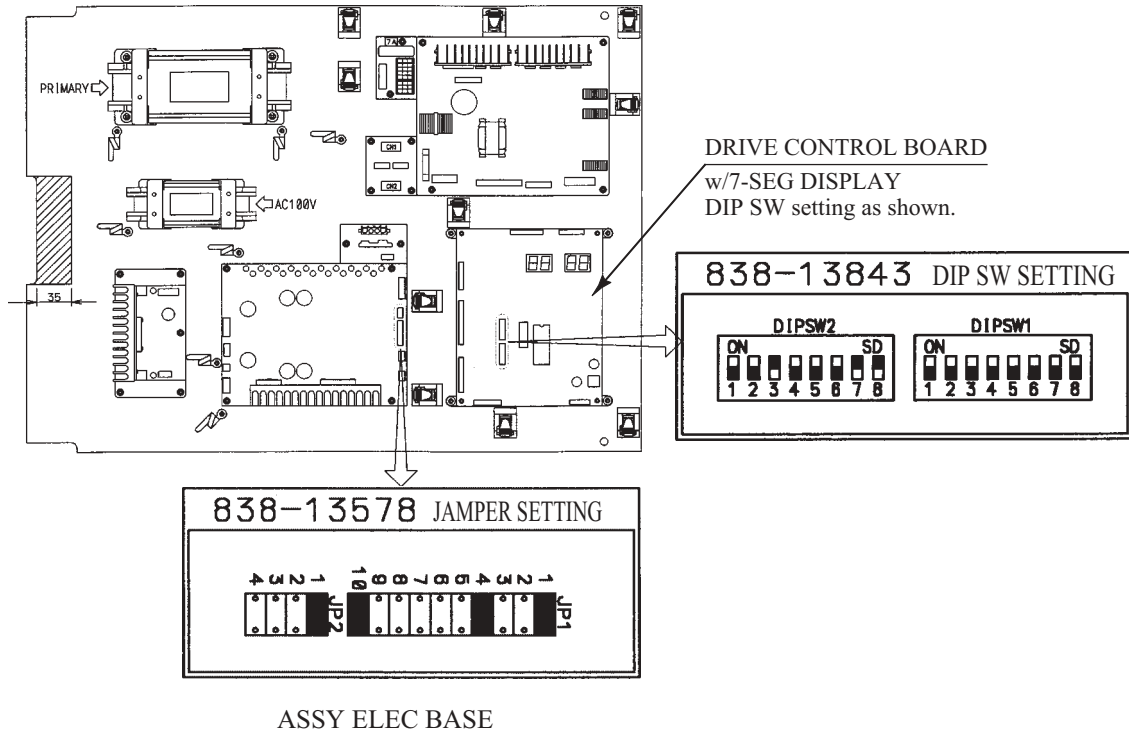

# 19. DESIGN RELATED PARTS

For the Warning Display stickers, refer to Section 1.

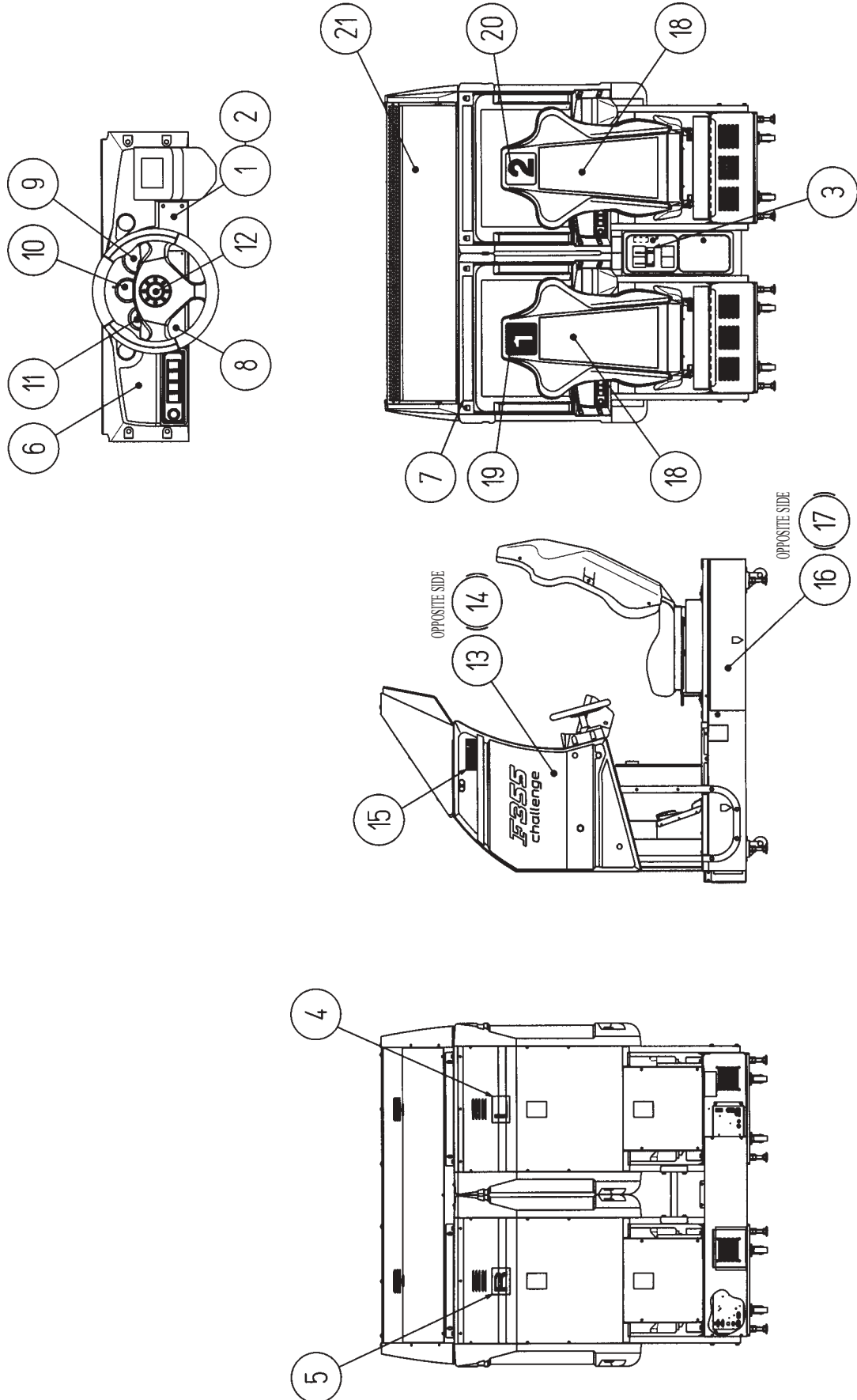

No.	PART No.	DESCRIPTION
1	DYN-0011	DENOMI PLATE W/O ORIGINAL
2	421-7308~	DENOMINATION SHEET 1 GAME Å
3	DYN-0303X	STICKER COIN ENTRY
4	421-8543	STICKER CABINET L
5	421-8544	STICKER CABINET R
6	422-0787-01	PLAY INSTR SH FRI TWIN ENG
7	422-0788-01	SUB INSTR SH FRI TWIN ENG
8	SPG-1201-E	METER PANEL
9	DYN-1214-C	DESIGN PL TACO MTR TWIN
10	DYN-1214-D	DESIGN PL OIL METER TWIN
11	DYN-1214-E	DESIGN PL WATER MTR TWIN
12	FRI-2002	STEERING EMBLEM FRI
13	FRI-1035-B	STICKER FRI TWIN SIDE L
14	FRI-1036-B	STICKER FRI TWIN SIDE R
15	421-9749-04	STICKER SEGA LOGO LUMI RED
16	FRI-1501-B	STICKER BASE FRI TWIN L
17	FRI-1501-C	STICKER BASE FRI TWIN R
18	FRI-1601-B	STICKER SEAT FRI TWIN
19	FRI-1601-C	STICKER NO.1 FRI TWIN
20	FRI-1601-D	STICKER NO.2 FRI TWIN
21	423-0337	BILLBOARD PLATE FRI TWIN

## 20. COMMUNICATION PLAY

For this game, 4 machines can be connected to allow up to 8 players to play simultaneously.

### 20 - 1 INSTALLATION PRECAUTIONS

- 1) When linking a number of machines, be sure to supply sufficient power for the corresponding number of machines. The per unit standard voltage/amperage is 100 X 120V/10A and 220 X 240V/5A.
- 2) Due to the length of the communications cable, the distance in between the machines will be approximately 0.2 meters or less.

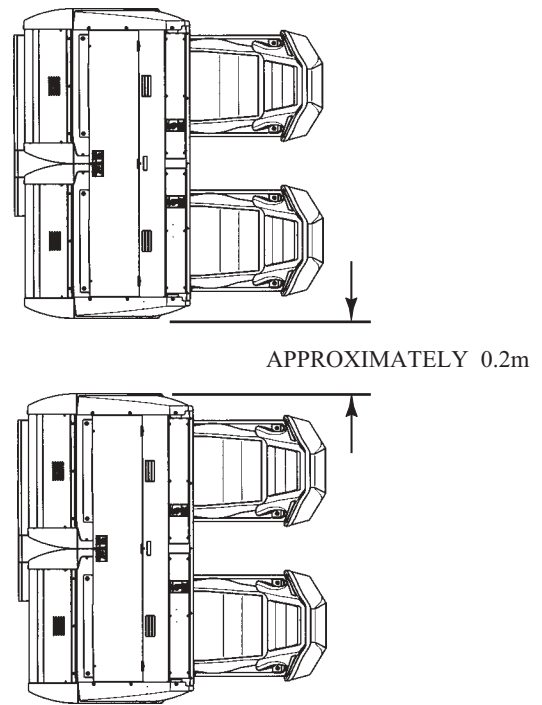

### 20 - 2 CONNECTING THE COMMUNICATION CABLES

The PROTECT TUBE is used to link plural machine units and the communication cables are caused to pass through the PROTECT TUBE. Depending on the number of machine units to be linked, connect the communication cables (optic fiber cables) in the manner shown in Figures 20. 2 f and 20. 2 g.

- ① Take off the 4 screws and remove AC COVER B (Fig. 20. 2 a).
- ② The HOLE LID is attached to the AC COVER HOLE into which the PROTECT TUBE is to be installed. By taking off 2 screws, remove the HOLE LID of the side where the PROTECT TUBE is to be installed.

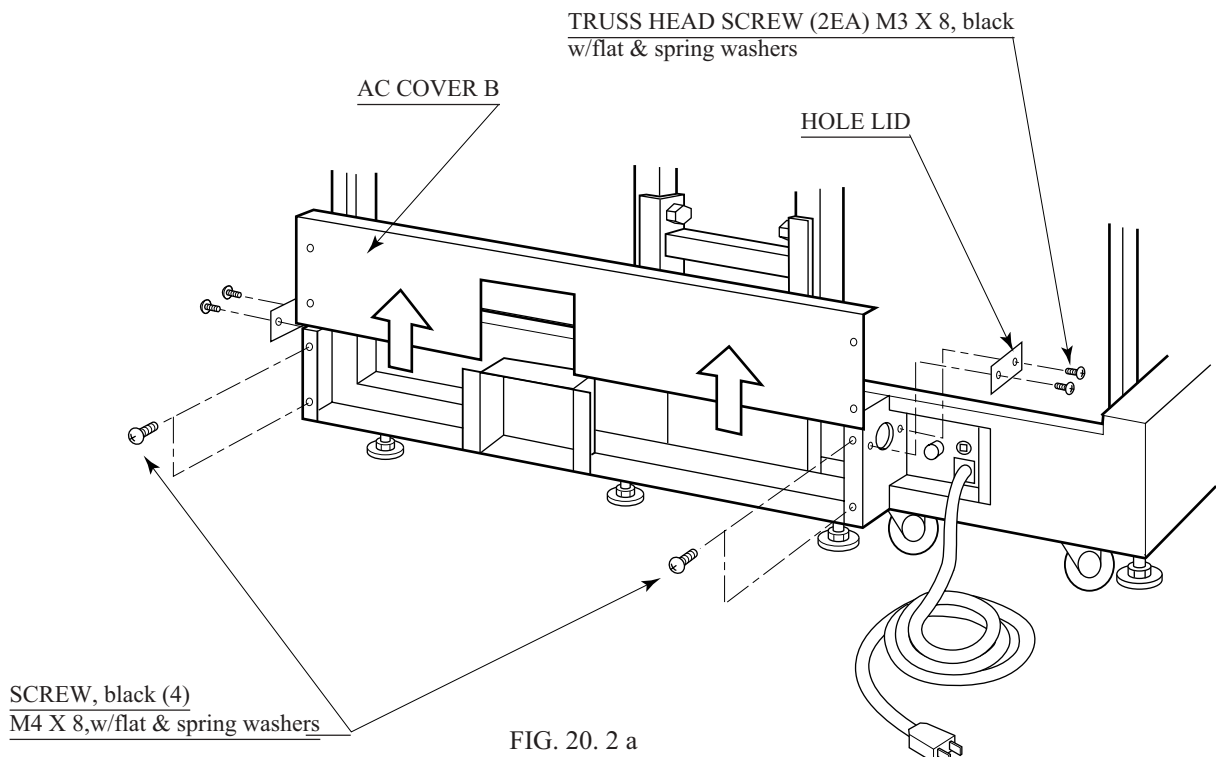

- ③ Attach CONNECTOR 22 to the both ends of FLEX TUBE, and assemble the PROTECT TUBE. First, disassemble CONNECTOR 22 (Fig. 20. 2 b).
- ④ First pass the plastic nut through the flex tube. Otherwise, the following work can not be performed and therefore, be very careful of this point.
- ⑤ Install the holder and then the "insert" to the end of the flex tube by turning them as in bolts and nuts (Fig. 20. 2 c).
- ⑥ Tighten the plastic nut to the connector. At this time, pass the optic fiber cable through the flex tube ahead of time so as to allow the following work to be performed easily (Fig. 20. 2 d).
- ⑦ Install the PROTECT TUBE into the AC COVER HOLE. Insert the connector into the AC COVER HOLE, put the seal washer through and fasten the metal nut (Fig. 20. 2 e).

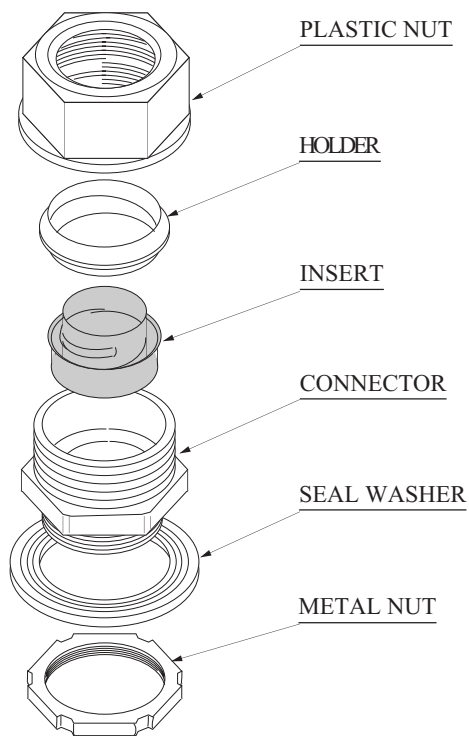

FIG. 20. 2 b

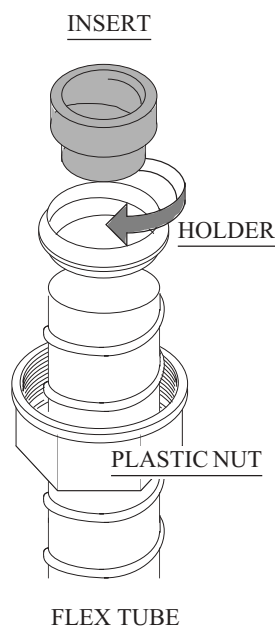

FIG. 20. 2 c

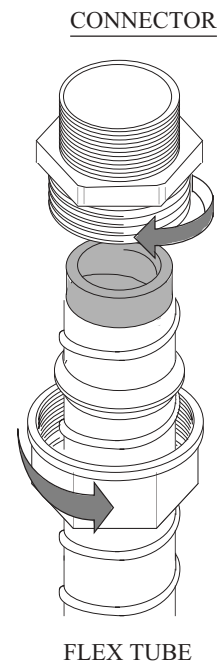

FIG. 20. 2 d

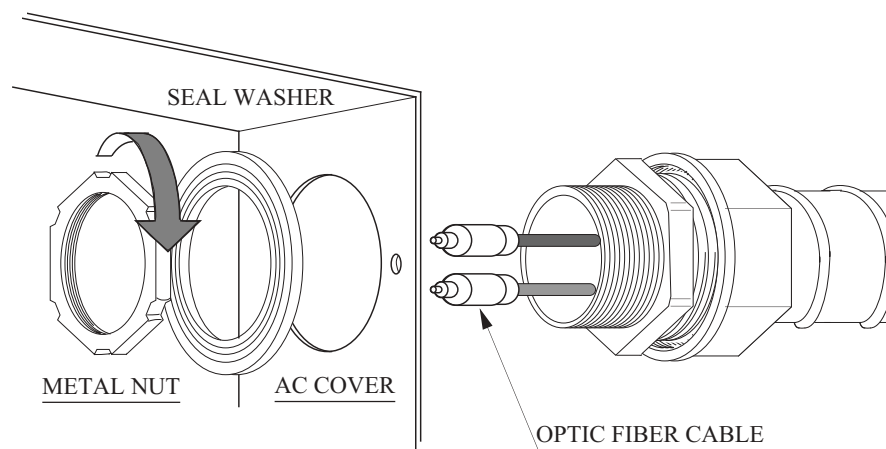

FIG. 20. 2 e

- ⑧ Connect the communication cable. Redo the connection which is currently made for TWIN (for 2P LINK). Depending on the number of units to be connected, communication connections are different. Make connection correctly as shown below.



The communication cable is optic-fiber made and will break if excessively bent. Handle with care.

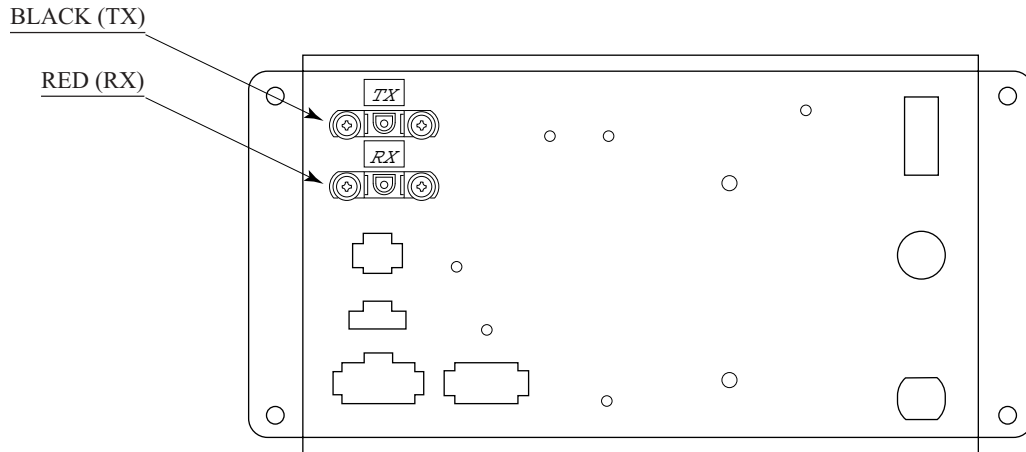

FIG. 20. 2 f AC UNIT

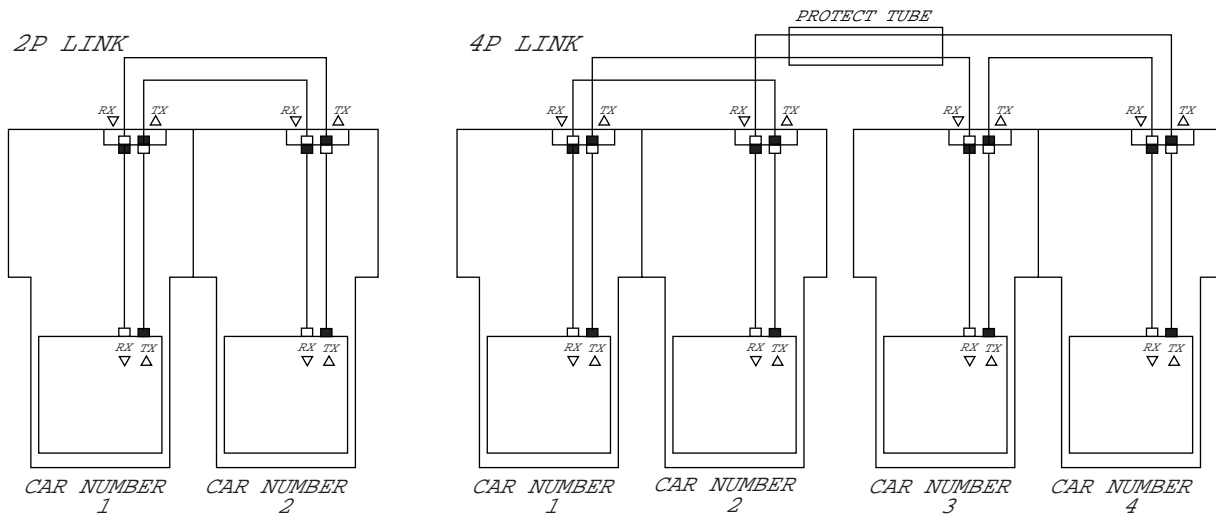

FIG. 20. 2 g

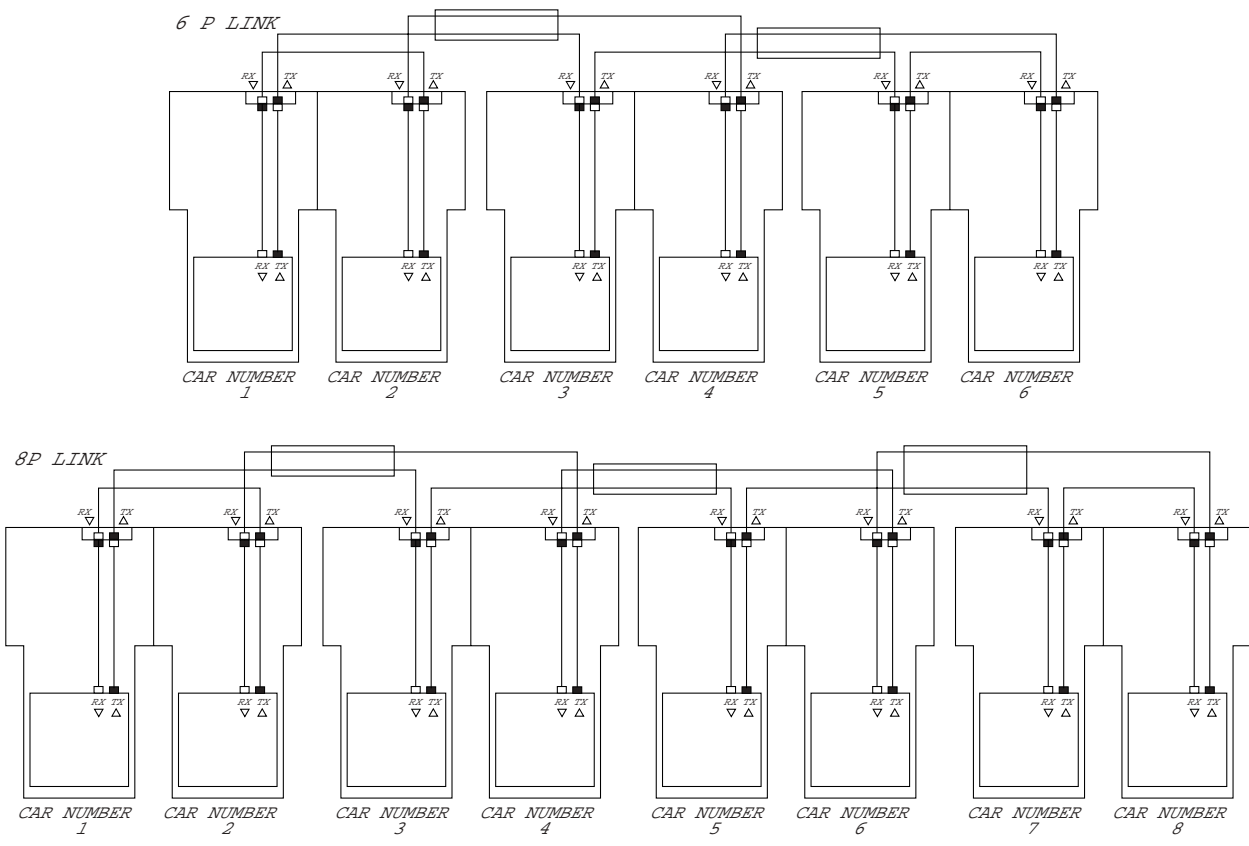

FIG. 20. 2 h

- ⑨ Apply Seat No. Stickers in the manner corresponding to applicable seats. The seats are numbered sequentially in order of 1, 2, 3, and 4 starting from the left facing the front of the Monitor (refer to Section 19).

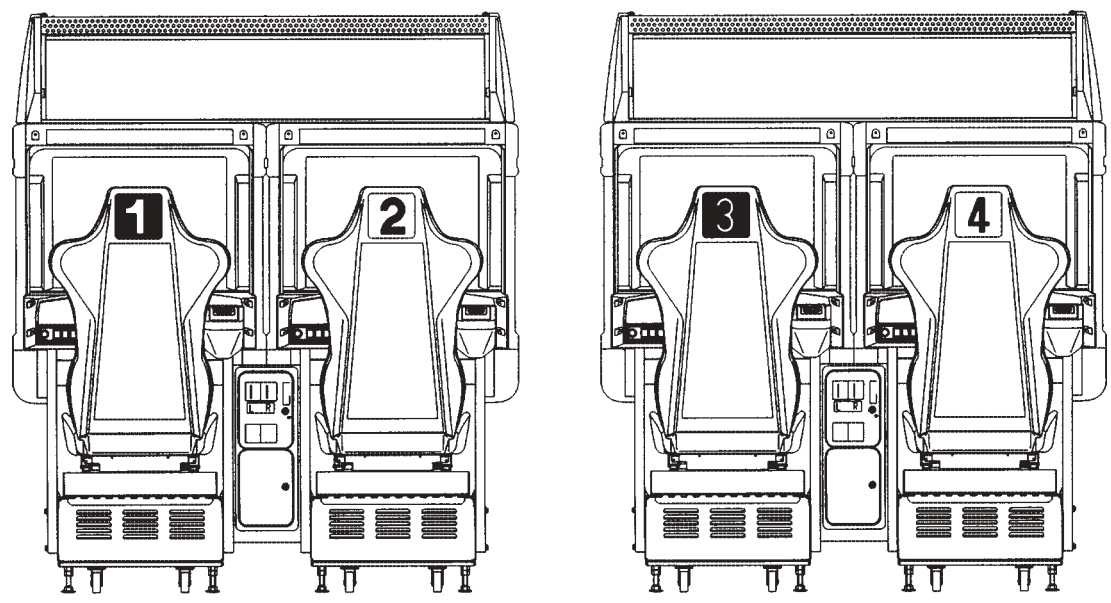

FIG. 20. 2 i



## 20 - 3 SETTING FOR COMMUNICATION PLAY



**IMPORTANT!**

During interactive play, if communication is interrupted due to some cause, the Network Check screen appears after finishing the game.

Cause all of the seats to enter the Test Mode and change the GAME ASSIGNMENTS of each seat for communication play. For the changing procedure, refer to the explanations of Section 9.

- ① Press TEST button to enter the test mode and proceed to GAME TEST mode. Choose GAME ASSIGNMENTS in the GAME TEST mode.
- ② Bring the arrow (->) to "LINK ID" and press TEST button to set one of the plural seats to MASTER. Set other seats to SLAVE.
- ③ Bring the arrow to "CAR NUMBER", press TEST button and set the linked machines sequentially to 1, 2, 3, and 4 as applicable starting from the extreme left facing the monitor's front side. If the same number is assigned to the 2 or more cabinets, or if the sequential order is incorrect, the game display, etc. will be confused (different from the actual status). Therefore, be careful of this point.

In the case of communication play, the settings of DIFFICULTY, GAME MODE, HANDICAP, CONTINUE, and LOCATION NAME ENTRY need to be performed by the MASTER seat. The other settings are to be performed by each seat.

■ GAME ASSIGNMENTS ■	
LINK ID	MASTER
CABINET	TWIN
CAR NUMBER	1
DIFFICULTY	NORMAL
GAME MODE	NORMAL(SPRINT)
HANDICAP	HEAT
CONTINUE	ANY NUMBER OF TIMES
MOTOR POWER	80%
VISUAL MEMORY	OFF
LOCATION NAME ENTRY	
-> EXIT	
SELECT WITH SERVICE BUTTON AND PRESS TEST BUTTON	

FIG. 20. 3 GAME ASSIGNMENTS

## 20 - 4 CAUTIONS TO BE HEEDED WHEN USING THE TEST MODE:

Exiting from the test mode causes the unit to perform the network check automatically. During this time, all of the linked units will not allow the game to be played in normal status. Therefore, be sure not to enter the test mode if any one of the units is in play. On the other hand, if even one unit is in the test mode, make sure that other machines are not in play.

# 21. PARTS LIST

## ① TOP ASSY FRI TWIN

(D-1/3)

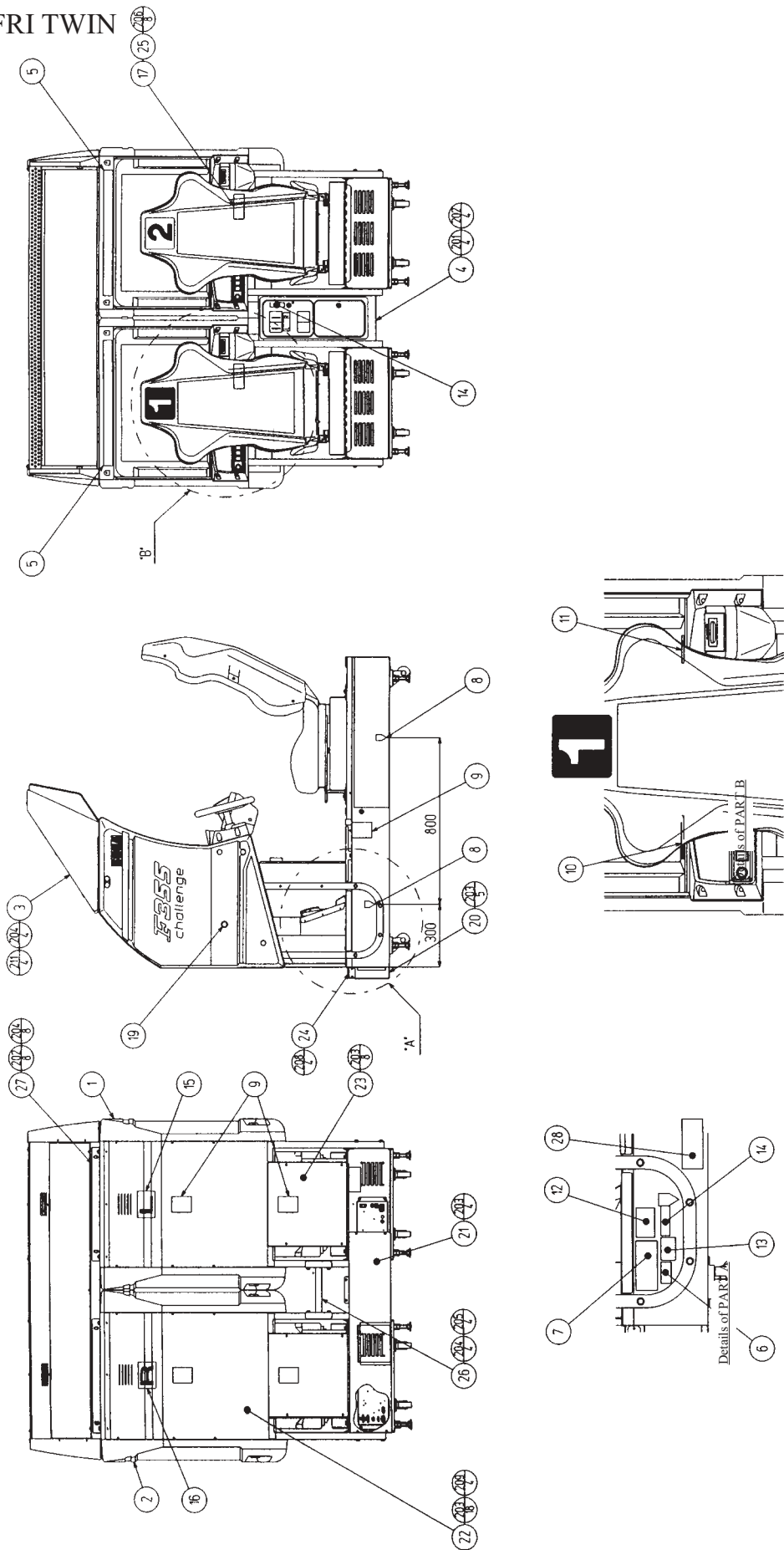

① TOP ASSY FRI TWIN

(D-2/3)

ITEM NO.	PART NO.	DESCRIPTION	NOTE
1	FRI-10001	ASSY COCKPIT 1P	
2	FRI-11001	ASSY COCKPIT 2P	
3	FRI-0200	ASSY BILLBOARD	
4	FRI-0300	ASSY COINCHUTE TOWER	
5	422-0788-01	SUB INSTR SH FRI TWIN ENG	
8	421-8885	STICKER CAUTION FORK	
9	440-WS0002XEG	STICKER W POWER OFF ENG	
10	440-CS0186-EG	STICKER C EPILEPSY 40 ENG	
15	421-8543	STICKER CABINET L	
16	421-8544	STICKER CABINET R	
17	421-7308~~	DENOMINATION SHEET 1GAME ~	
18	SGM-3863	POLTHN COVER 950 X 1800 X 1700	
19	SPG-0005	BLIND CAP	
20	SPG-0006X	AC COVER A	
21	DYN-0006X	AC COVER B	
22	INY-0004	BACK LID INY	
23	DYN-0008	BACK LID B	
24	DYN-0009	HOLE LID	
25	DYN-0011	DENOMI PLATE W/O ORIGINAL	
26	DYN-0013	JOINT PIPE	
27	SPG-0008	BILLBOARD HOLDER	
101	600-6275-0500	ASSY FIBER CABLE 5 0500CM	
102	280-5009-01	CORD CLAMP 21	
103	601-0460	PLASTIC TIE BELT 100 MM	
201	030-000820-S	HEX BLT W/S M8 X 20	
202	068-852216-0B	FLT WSHR BLK 8.5-22 X 1.6	
203	000-P00408-WB	M SCR PH W/FS BLK M4 X 8	
204	030-000825-SB	HEX BLT W/S BLK M8 X 25	
205	060-F00800-0B	FLT WSHR BLK M8	
206	000-T00416-0C	M SCR TH CRM M4 X 16	
207	000-T00512-0B	M SCR TH BLK M5 X 12	
208	000-P00308-WB	M SCR PH W/FS BLK M3 X 8	
209	010-P00408-F	S-TITE SCR PH W/F M4 X 8	
210	008-T00412-0B	TMP PRF SCR TH BLK M4 X 12	
211	SLC-0006	FLAT WASHER 8.4-25 X 2	
212	050-H00400	HEX NUT M4	
213	060-F00400	FLT WSHR M4	
214	060-S00400	SPR WSHR M4	
301	600-7076-071	WIRE HARN EXT AC LINE	
302	FRI-61044	WIRE HARN EXT WOOFER VR L A	
303	FRI-61045	WIRE HARN EXT WOOFER VR R A	
304	FRI-61046	WIRE HARN EXT COIN L A	
305	FRI-61047	WIRE HARN EXT COIN R A	

① TOP ASSY FRI TWIN

(D-3/3)

ITEM NO.	PART NO.	DESCRIPTION	NOTE
401	601-6604-70	CARTON BOX 70	
402	420-6507-05	OWNERS MNL FRI TWIN ENG	
403	SGM-2675	POLYETHYLENE BAG, 240 X 370	
404	220-5576	KEY MASTER FOR 220-5575	
405	SGM-4111	KEY BAG (SGB-1035X)	
407	540-0009-01	WRENCH FOR TAMP SCR M8	
408	220-5484	VOL CONT B-5K OHM	
	220-5373	VOL CONT B-5K	
409	310-5050-220090	FLEX TUBE 22-0090CM	
410	310-5051-22	CONN 22	
411	509-5387	SW MICRO TYPE (AH71557K)	
412	DYN-0020	JOINT PLATE	
414	514-5036-7000	FUSE 6.4 X 30 7000MA 125V	
415	600-6724	AC CABLE CONNECT TYPE 15A	1 2 3 AC 110V AREA
	600-6729	AC CABLE CONNECT TYPE 15A	
	600-6618	AC CABLE CONNECT TYPE FOR EXP	
416	421-11210	STICKER NO. OPTION FRI TWIN	
417	NOA-1506	LID VM	
418	421-11223	INSTR SH VMLID	
/	421-6690-03	STICKER 220V	AC 220V AREA
/	421-6690-05	STICKER 240V	AC 240V AREA
/	421-6690-06	STICKER 110V	AC 110V AREA

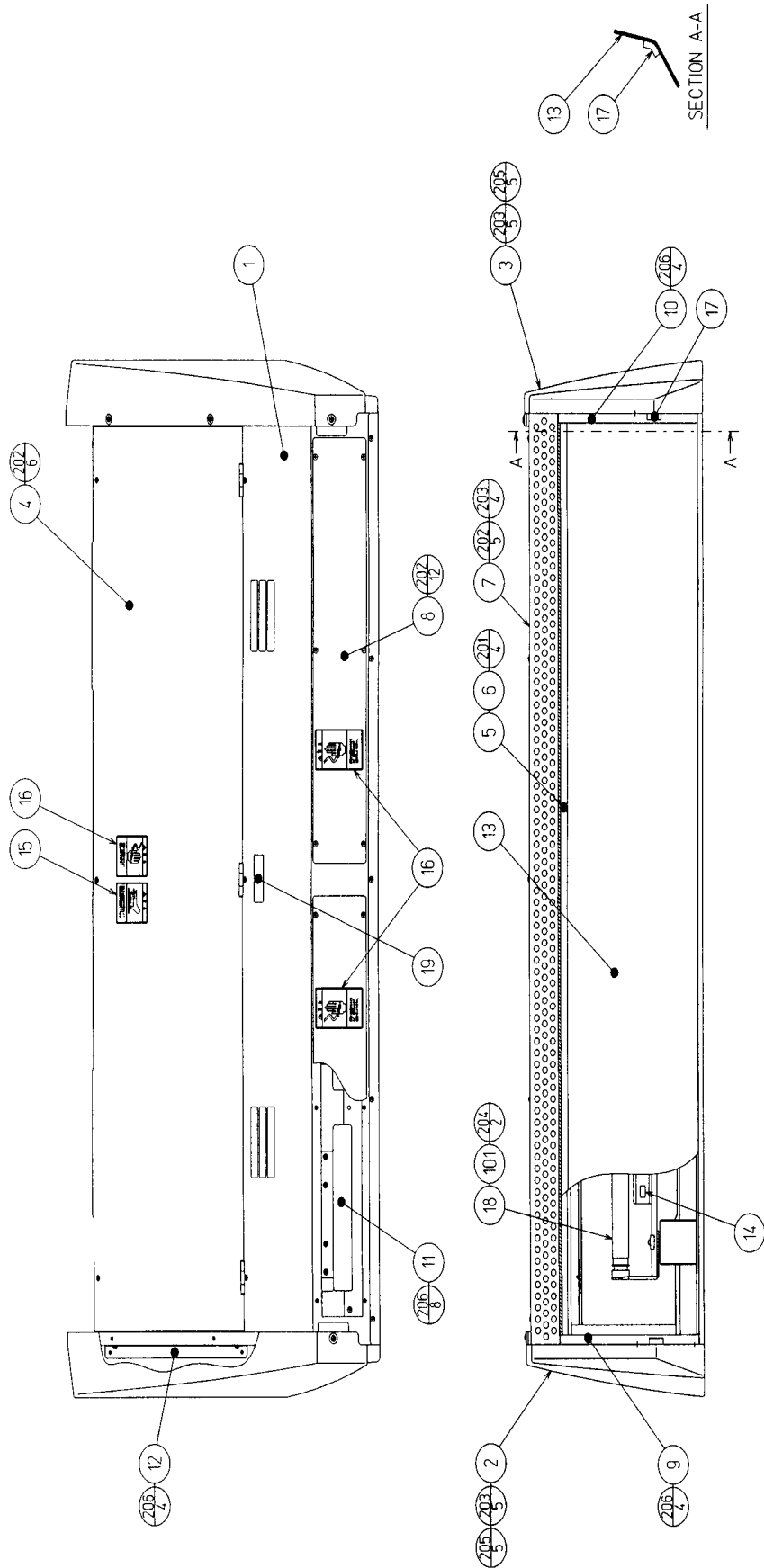

② ASSY BILLBOARD (FRI-0200)

(D-2/2)

ITEM NO.	PART NO.	DESCRIPTION	NOTE
1	FRI-0201	BILLBOARD BOX	
2	FRI-0202	SIDE COVER L	
3	FRI-0203	SIDE COVER R	
4	FRI-0204	BILLBOARD LID	
5	FRI-0205	UPPER SASH	
6	FRI-0206	LIGHT PLATE	
7	FRI-0207	UPPER COVER	
8	FRI-0208	UPPER LID	
9	FRI-0209	SIDE SASH L	
10	FRI-0210	SIDE SASH R	
11	FRI-0220	ASSY LIGHT	
12	VOT-0208	SIDE COVER BRKT	
13	423-0337	BILLBOARD PLATE FRI TWIN	
14	421-7501-10	STICKER FL 40W	
15	440-WS0012XEG	STICKER W HIGH TEMP ENG	
16	440-WS0002XEG	STICKER W POWER OFF ENG	
17	FRI-0211	CUSHION SPONGE 40	
18	253-5457	FL HOLDER	
101	390-6659-40EX	ASSY FL40W EX W/CONN HIGH S CE	
	390-6603-40EX	ASSY FL40W EX W/CONN HIGH T CE	
102	280-5277	CORD CLAMP 18	
103	280-5275-SR10	CORD CLAMP SR10	
201	000-F00410	M SCR FH M4 X 10	
202	000-T00408-0B	M SCR TH BLK M4 X 8	
203	000-T00412-0B	M SCR TH BLK M4 X 12	
204	000-P00430-W	M SCR PH W/FS M4 X 30	
205	068-441616-0B	FLT WSHR BLK 4.4-16 X 1.6	
206	000-P00408-W	M SCR PH W/FS M4 X 8	
207	050-H00400	HEX NUT M4	
208	060-F00400	FLT WSHR M4	
209	060-S00400	SPR WSHR M4	
301	FRI-61064	WIRE HARN INVERTER	
302	FRI-61066	WIRE HARN FL	

### ③ ASSY LIGHT (FRI-0220)

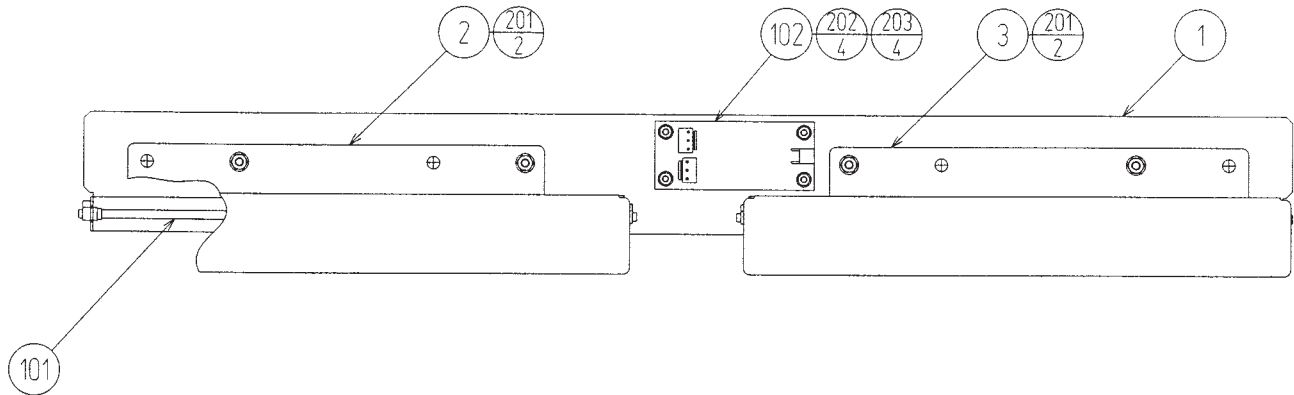

ITEM NO.	PART NO.	DESCRIPTION	NOTE
1	FRI-0221	HOLDER	
2	FRI-0222	HOLDER PLATE A	
3	FRI-0223	HOLDER PLATE B	
101	390-5697-01	CATHODE TUBE PINK W/CONN	
102	838-13038	CATHODE TUBE INVERTER 12V	
103	280-5275-SR10	CORD CLAMP SR10	
104	601-0460	PLASTIC TIE BELT 100 MM	
201	050-F00400	FLG NUT M4	
202	050-U00300	U NUT M3	
203	060-F00300	FLT WSHR M3	

④ ASSY COINCHUTE TOWER (FRI-0300)

(D-1/2)

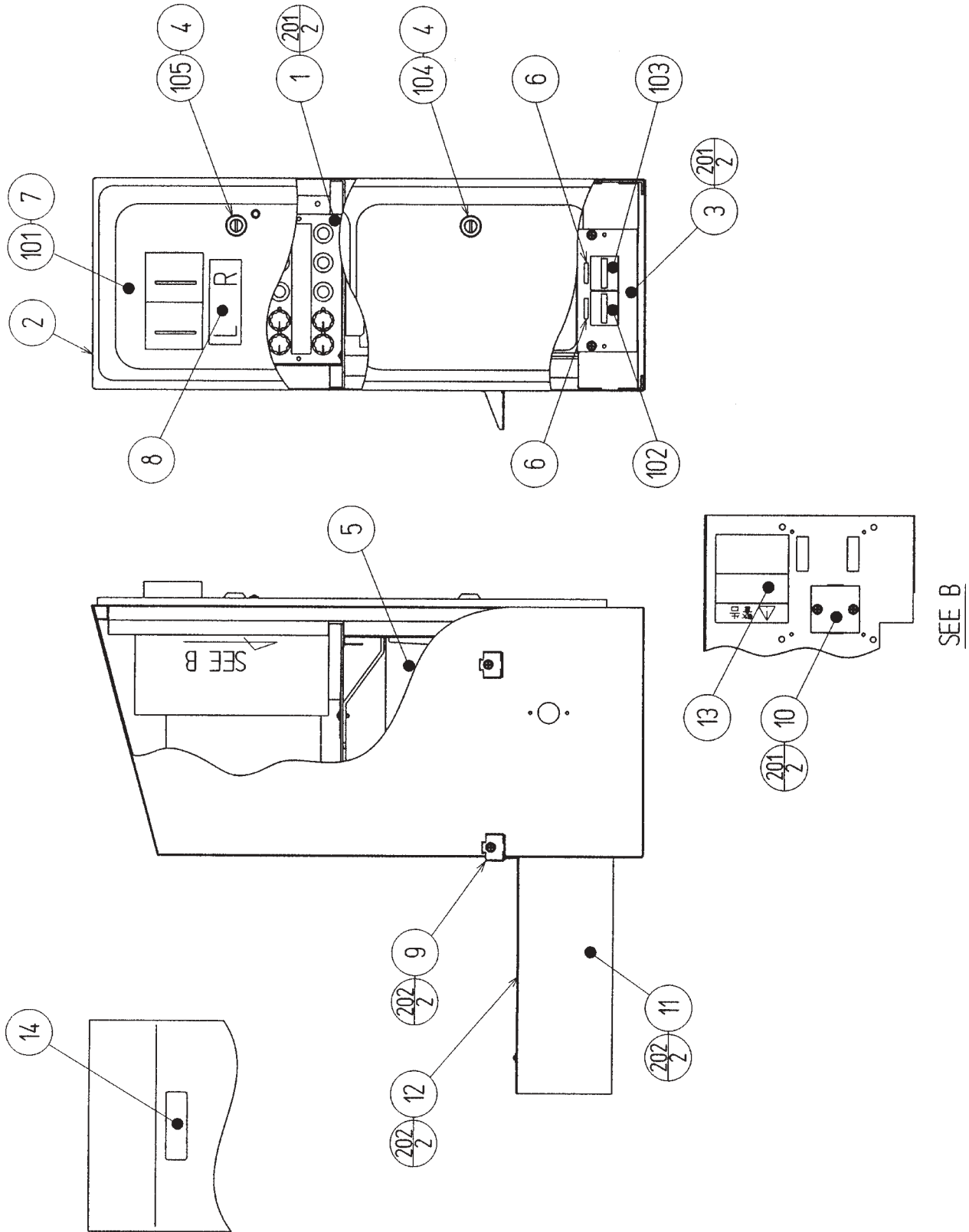



④ ASSY COINCHUTE TOWER (FRI-0300)

(D-2/2)

ITEM NO.	PART NO.	DESCRIPTION	NOTE
1	FRI-0350	SW UNIT	
2	SPG-0301	COIN CHUTE TOWER	
3	DRT-0301	COIN METER BRKT	
4	DP-1167	TNG LKG	
5	253-5366	CASH BOX	
6	421-6591-01	STICKER COIN METER	
7	421-7501-02	STICKER 6.3V 0.15A	
8	DYN-0303X	STICKER COIN ENTRY	
9	DYN-0305	TOWER BRKT	
10	105-5202	HOLE COVER	
11	SPG-0302	WIRE BOX	
12	SPG-0303	WIRE BOX LID	
13	440-WS0002XEG	STICKER W POWER OFF ENG	
101	220-5482-91~ 220-5237-92~	ASSY COIN CHUTE 2DOOR ~ ASSY COIN CHUTE 2DOOR ~	
102	220-5643-01	MAG CNTR DC5V 6P WH MZ-674-D04	
103	220-5643-02	MAG CNTR DC5V 6P YE MZ-674-D05	
104	220-5574	CAM LOCK W/KEYS	
105	220-5575	CAM LOCK MASTER W/O KEY	
106	280-5009-01	CORD CLAMP 21	
107	280-5275-SR10	CORD CLAMP SR10	
108	601-0460	PLASTIC TIE BELT 100 MM	
109	310-5029-F20	SUMITUBE F F 20MM	
110	601-6231-C045	EDGING NEW TYPE	
201	000-P00412-W	M SCR PH W/FS M4 X 12	
202	000-T00408-0B	M SCR TH BLK M4 X 8	
203	010-P00408-F	S-TITE SCR PH W/F M4 X 8	
301	600-6373-50	WIRE HARN COIN LEFT	
302	600-6373-51	WIRE HARN COIN RIGHT	
303	600-7076-072	WIRE HARN EARTH EXT COIN CHUTE	
304	600-7076-073	WIRE HARN EARTH COIN CHUTE	
305	600-6972-0130	WIRE HARN EARTH ID5 0130MM	
306	FRI-61048	WIRE HARN EXT WOOFER VR L B	
307	FRI-61049	WIRE HARN EXT WOOFER VR R B	
308	FRI-61050	WIRE HARN EXT COIN L B	
309	FRI-61051	WIRE HARN EXT COIN R B	
310	FRI-61052	WIRE HARN EXT COIN L C	
311	FRI-61053	WIRE HARN EXT COIN R C	
312	FRI-61054	WIRE HARN EXT WOOFER VR L C	
313	FRI-61055	WIRE HARN EXT WOOFER VR R C	
314	FRI-61056	WIRE HARN EXT COIN L D	
315	FRI-61057	WIRE HARN EXT COIN R D	
316	FRI-61058	WIRE HARN EXT COIN L E	
317	FRI-61059	WIRE HARN EXT COIN R E	

5 SW UNIT (FRI-0350)

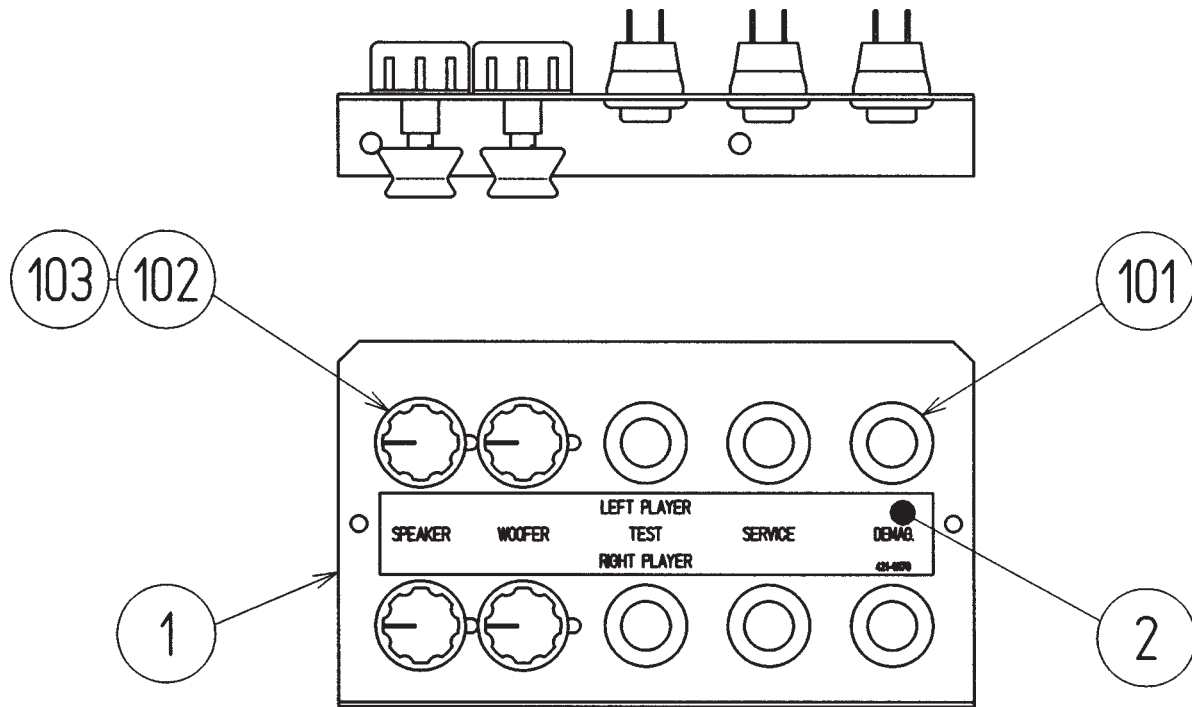

ITEM NO.	PART NO.	DESCRIPTION	NOTE
1	SPG-0351	SW BRKT	
2	421-11170	STICKER SW UNIT FRI	
101	509-5028	SW PB 1M	
102	220-5179	VOL CONT B-5K OHM	
103	601-0042	KNOB 22 MM	
104	601-0460	PLASTIC TIE BELT 100 MM	
105	310-5029-F20	SUMITUBE F F 20MM	
301	600-6373-53	WIRE HARN TEST & SERVICE LEFT	
302	600-7076-055	WIRE HARN VOL LEFT YE	
303	600-6373-67	WIRE HARN TEST & SERVICE RIGHT	
304	600-7076-065	WIRE HARN VOL RIGHT BL	
305	600-6873-064	WIRE HARN S.VOLUME 1P	
306	600-6873-065	WIRE HARN S.VOLUME 2P	

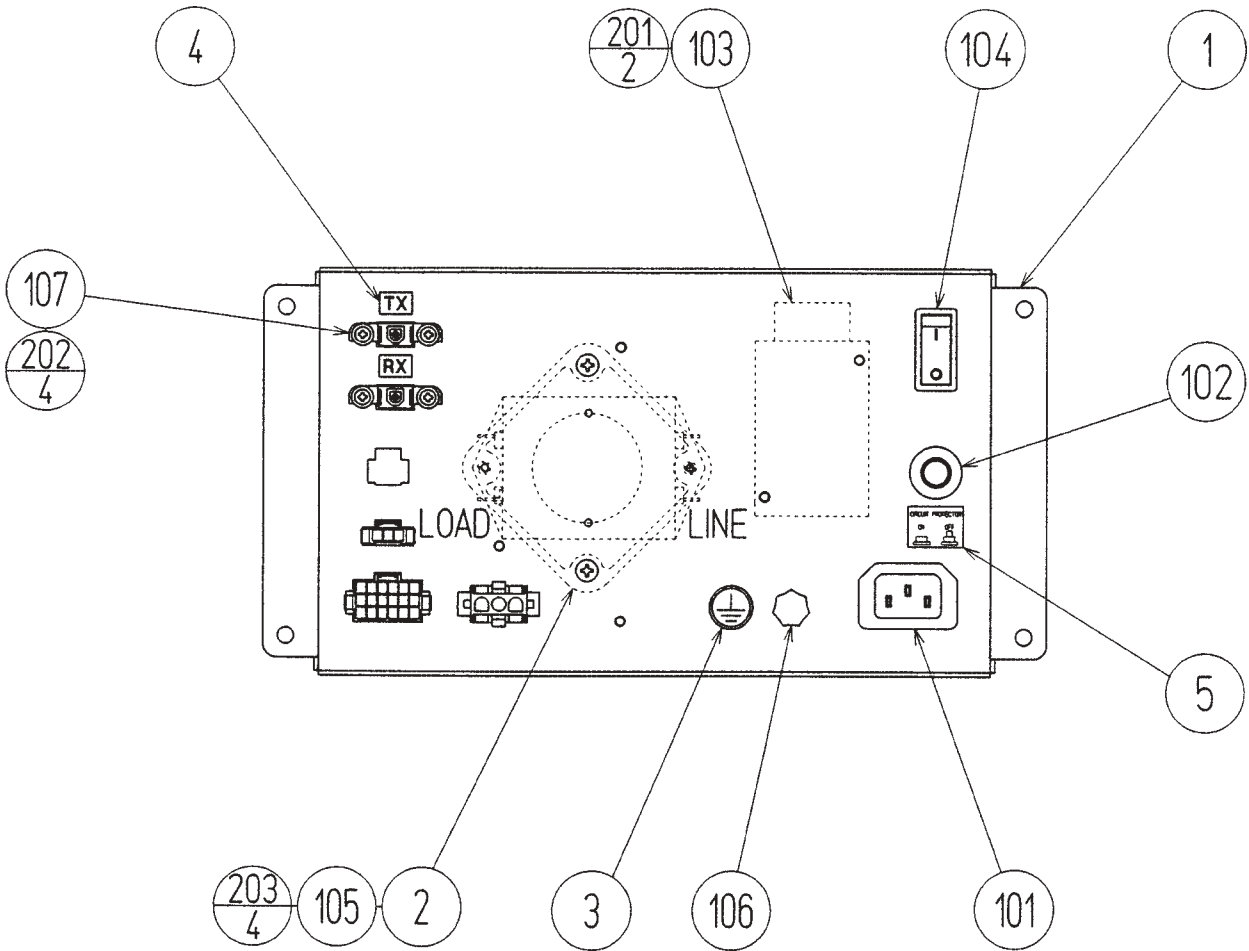

⑥ AC UNIT MAIN (FRI-0400)

(D-2/2)

ITEM NO.	PART NO.	DESCRIPTION	NOTE
1	APC-1531	AC BRKT	
2	DYN-0402	NOISE FILTER BASE	
3	421-8202	STICKER EARTH MARK	
4	421-7515	STICKER FIBER CABLE TX/RX	
5	421-7468-01	STICKER C.P W/PIC	
101	214-0202	AC INLET PANEL TYPE	
102	512-5046-15000	C.P 15000MA CE UL	AC 110V AREA
	512-5046-8000	C.P 8000MA CE UL	AC 220 ~ 240V AREA
103	450-5126	MAGNET CONTACT S-NIOCX	AC 110V AREA
	450-5134	MAGNET CONTACT S-NIOCX AC 230V	AC 220 ~ 240V AREA
	450-5133	MAGNET CONTACT S-NIOCX AC 200V	AC 200V AREA
104	509-5453-91-V-B	SW ROCKER J8 V-B	
105	270-5115	NOISE FILTER 15A GT-215J	
106	280-0417	TERMINAL BINDING POST BLACK	
107	211-5479-01	CONN OPT JOINT(TOCA150S)	
108	310-5029-K20	SUMITUBE F K 20MM	
109	280-5009-01	CORD CLAMP 21	
110	601-0460	PLASTIC TIE BELT 100 MM	
201	000-P00416-WB	M SCR PH W/FS BLK M4 X 16	
202	000-P00312-W	M SCR PH W/FS M3 X 12	
203	012-P00408	TAP SCR #2 PH 4 X 8	
301	FRI-61020	WIRE HARN AC UNIT IN	
302	FRI-61021	WIRE HARN MAIN SW	
303	FRI-61022	WIRE HARN M.CONTACT & N.FILTER	
304	FRI-61023	WIRE HARN AC UNIT OUT	
305	FRI-61024	WIRE HARN N.FILTER & XFMR	
306	FRI-61025	WIRE HARN EARTH INLET	
307	FRI-61026	WIRE HARN EXT AC UNIT	

⑦ AC UNIT SUB (FRI-0700)

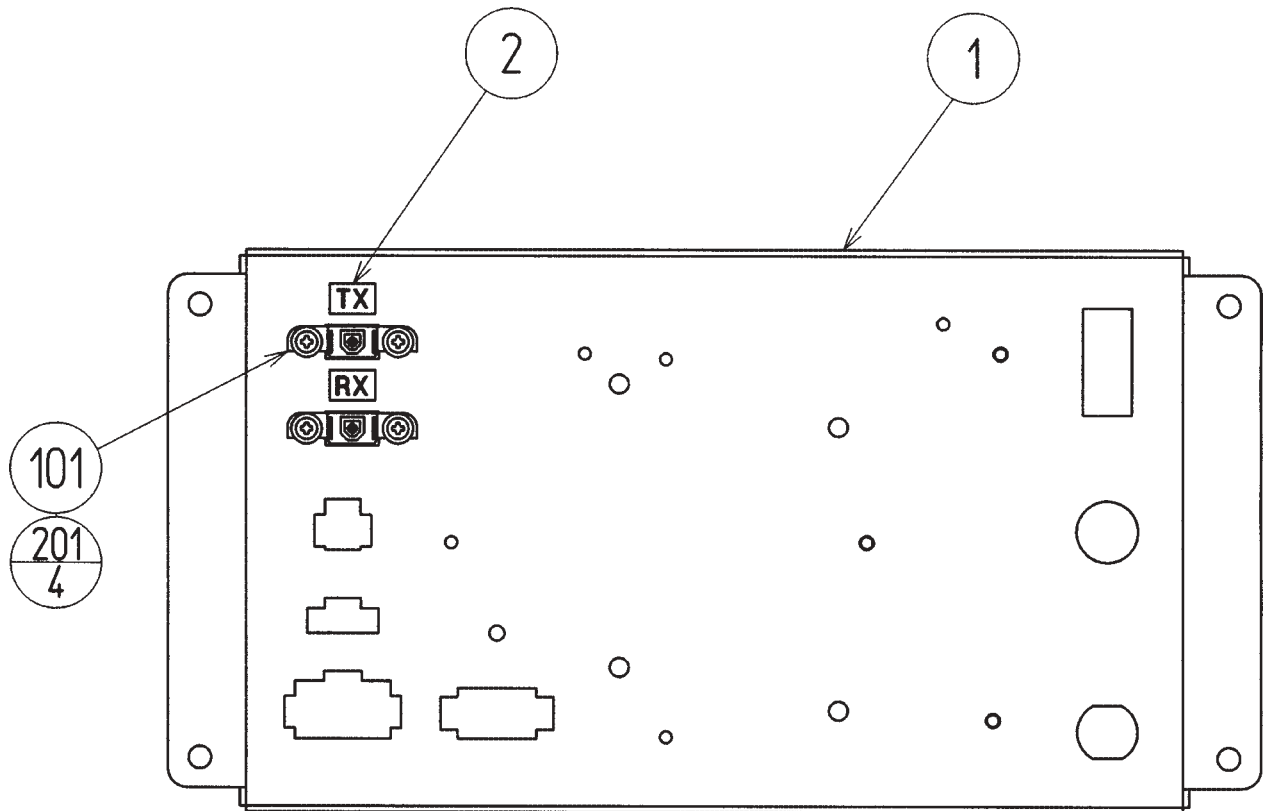

ITEM NO.	PART NO.	DESCRIPTION	NOTE
1	APC-1531	AC BRKT	
2	421-7515	STICKER FIBER CABLE TX/RX	
101	211-5479-01	CONN OPT JOINT	
201	000-P00312-W	M SCR PH W/FS M3 X 12	
301	FRI-61026	WIRE HARN EXT AC UNIT	
302	FRI-61037	WIRE HARN EXT AC UNIT SUB	

8 ASSY COCKPIT 1P (FRI-10001)

(D-1/2)

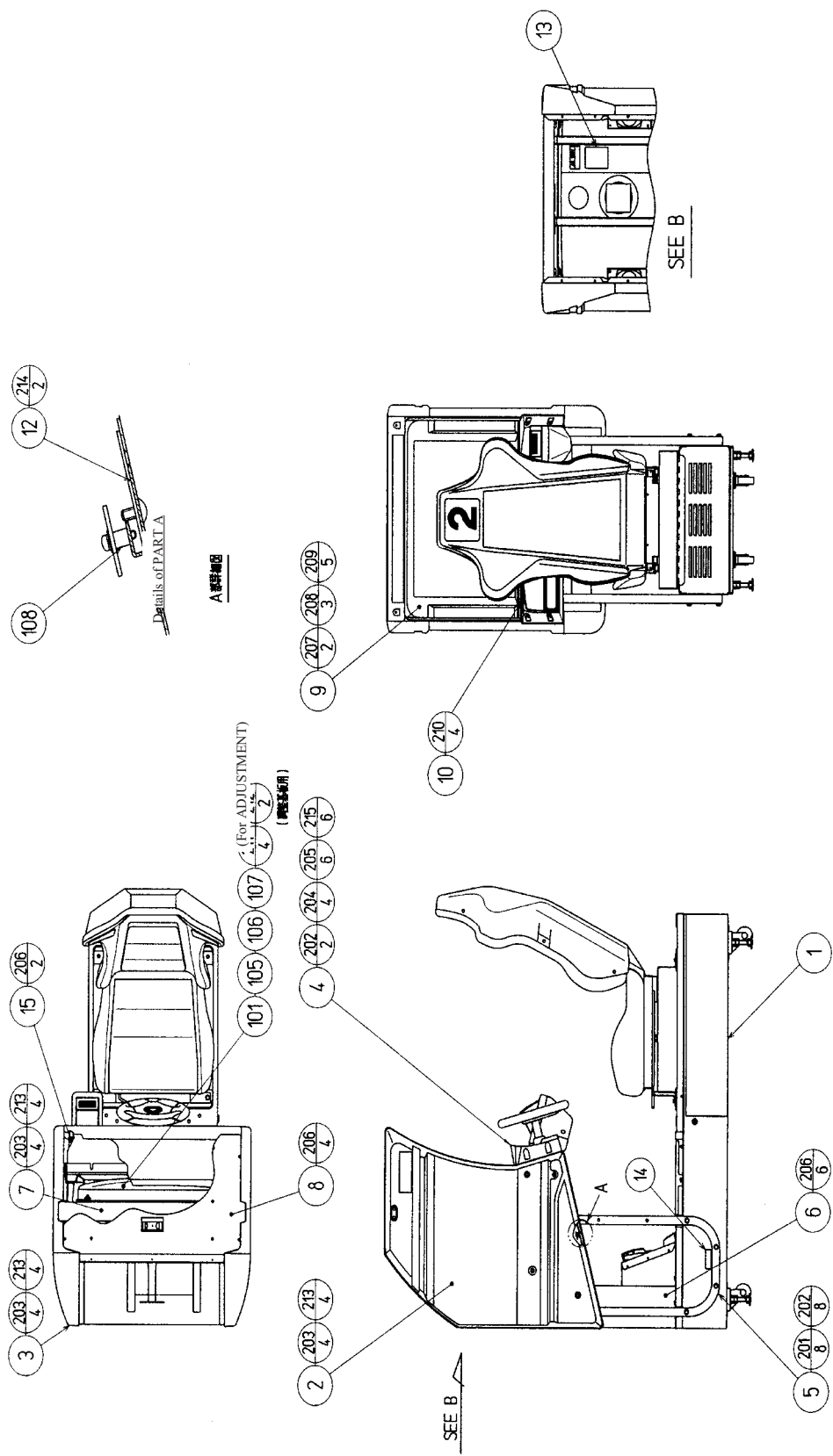

⑧ ASSY COCKPIT 1P (FRI-10001)

(D-2/2)

ITEM NO.	PART NO.	DESCRIPTION	NOTE
1	FRI-20001	ASSY MAIN BASE 1P	
2	FRI-1035	MONITOR COVER L	
3	FRI-1036-A	COVER PANEL R BLANK	
4	FRI-12001-01	ASSY CONTROL PANEL TWIN EXP	
5	SPG-1004X	MONITOR STAND	
6	FRI-1025	WIRE COVER BOX	
7	INY-1016	MONITOR SUPPORT	
8	SPG-1008	ROOF LID	
9	TTR-1067X	MONITOR MASK	
10	SPG-1005	MASK HOLDER	
12	INY-1015	CRT ADJUST PANEL	
13	440-DS0013XEG	STICKER D MONITOR ENG	
15	DYN-1032	MASK BRKT	
101	200-5787	ASSY CLR DSPL 29TYPE 31K 100V	
102	280-5009-01	CORD CLAMP 21	
103	280-5275-SR10	CORD CLAMP SR10	
104	601-0460	PLASTIC TIE BELT 100 MM	
105	280-5112	BUSH FOR TV	
106	280-5113	COLLAR FOR TV	
107	280-5114	SPACER 6.4-25 X 2	
108	280-5185-6	SPACER TUBE L=6	
109	601-6231-C100	EDGING NEW TYPE	
110	270-5117	FERRITE CORE TDK ZCAT3035-1330	
201	030-000850-SB	HEX BLT W/S BLK M8 X 50	
202	068-852216-0B	FLT WSHR BLK 8.5-22 X 1.6	
203	030-000840-SB	HEX BLT W/S BLK M8 X 40	
204	060-F00800-0B	FLT WSHR BLK M8	
205	008-B00830-0B	TMP PRF SCR BH BLK M8 X 30	
206	000-P00408-WB	M SCR PH W/FS BLK M4 X 8	
207	000-T00530-0B	M SCR TH BLK M5 X 30	
208	000-T00512-0B	M SCR TH BLK M5 X 12	
209	068-552016-0B	FLT WSHR BLK 5.5-20 X 1.6	
210	000-F00508	M SCR FH M5 X 8	
211	050-F00600	FLG NUT M6	
212	000-P00312-WB	M SCR PH W/FS BLK M3 X 12	
213	DYN-1019	FLT WASHER M8	
214	000-T00408-0B	M SCR TH BLK M4 X 8	
215	060-S00800-0B	SPR WSHR BLK M8	
216	010-P00408-F	S-TITE SCR PH W/F M4 X 8	
301	FRI-6103	ASSY WIRE COCKPIT DC	
302	FRI-6104	ASSY WIRE COCKPIT AC	
303	600-6972-1250	WIRE HARN EARTH ID5 1250MM	

9 ASSY COCKPIT 2P (FRI-11001)

(D-1/2)

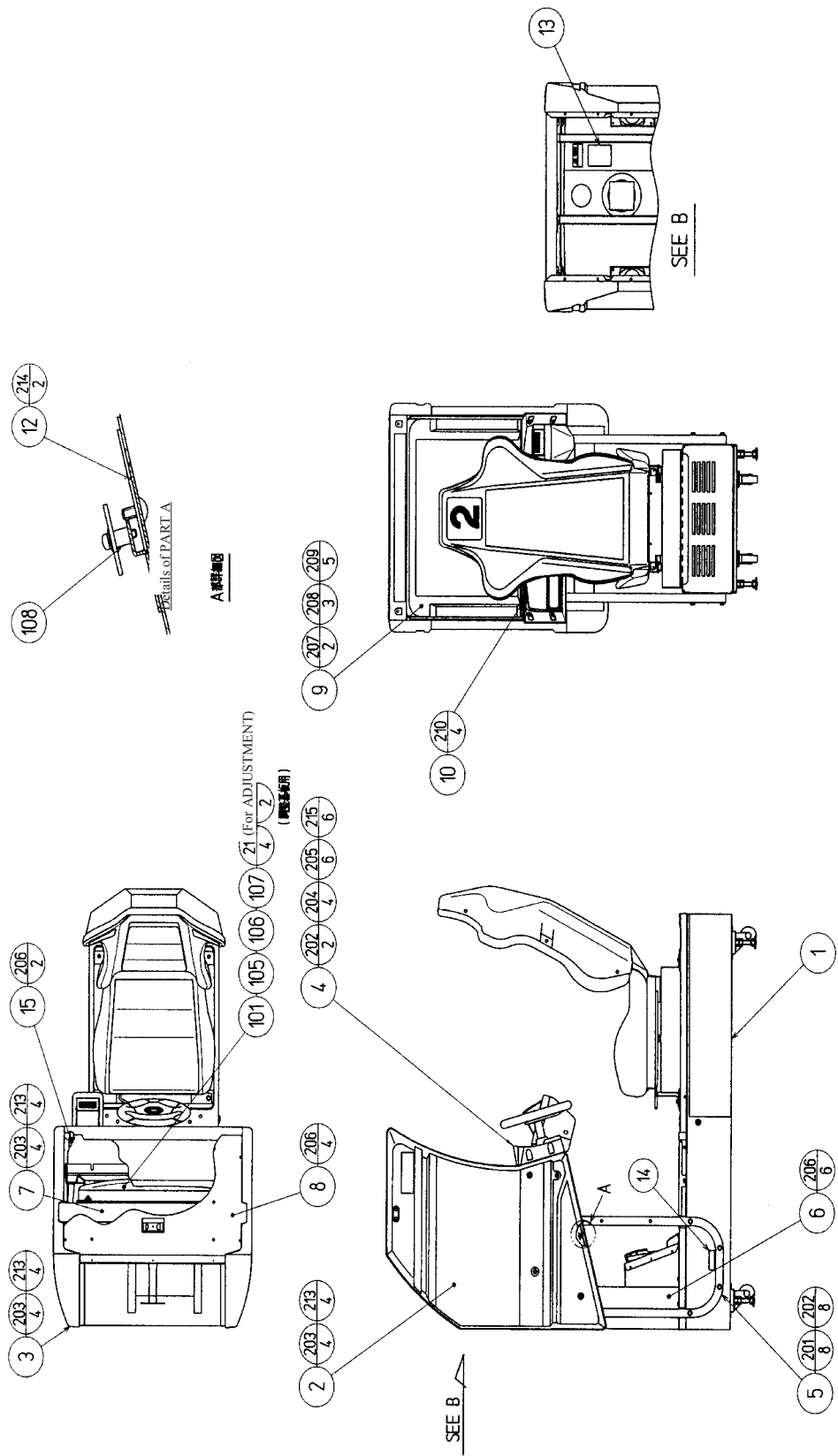



⑨ ASSY COCKPIT 2P (FRI-11001)

(D-2/2)

ITEM NO.	PART NO.	DESCRIPTION	NOTE
1	FRI-21001	ASSY MAIN BASE 2P	
2	FRI-1035-A	COVER PANEL L BLANK	
3	FRI-1036	MONITOR COVER R	
4	FRI-12001-01	ASSY CONTROL PANEL TWIN EXP	
5	SPG-1004X	MONITOR STAND	
6	FRI-1025	WIRE COVER BOX	
7	INY-1016	MONITOR SUPPORT	
8	SPG-1008	ROOF LID	
9	TTR-1067X	MONITOR MASK	
10	SPG-1005	MASK HOLDER	
12	INY-1015	CRT ADJUST PANEL	
13	440-DS0013XEG	STICKER D MONITOR ENG	
15	DYN-1032	MASK BRKT	
101	200-5787	ASSY CLR DSPL 29TYPE 31K 100V	
102	280-5009-01	CORD CLAMP 21	
103	280-5275-SR10	CORD CLAMP SR10	
104	601-0460	PLASTIC TIE BELT 100 MM	
105	280-5112	BUSH FOR TV	
106	280-5113	COLLAR FOR TV	
107	280-5114	SPACER 6.4-25 X 2	
108	280-5185-6	SPACER TUBE L=6	
109	601-6231-C100	EDGING NEW TYPE	
110	270-5117	FERRITE CORE TDK ZCAT3035-1330	
201	030-000850-SB	HEX BLT W/S BLK M8 X 50	
202	068-852216-0B	FLT WSHR BLK 8.5-22 X 1.6	
203	030-000840-SB	HEX BLT W/S BLK M8 X 40	
204	060-F00800-0B	FLT WSHR BLK M8	
205	008-B00830-0B	TMP PRF SCR BH BLK M8 X 30	
206	000-P00408-WB	M SCR PH W/FS BLK M4 X 8	
207	000-T00530-0B	M SCR TH BLK M5 X 30	
208	000-T00512-0B	M SCR TH BLK M5 X 12	
209	068-552016-0B	FLT WSHR BLK 5.5-20 X 1.6	
210	000-F00508	M SCR FH M5 X 8	
211	050-F00600	FLG NUT M6	
212	000-P00312-WB	M SCR PH W/FS BLK M3 X 12	
213	DYN-1019	FLT WASHER M8	
214	000-T00408-0B	M SCR TH BLK M4 X 8	
215	060-S00800-0B	SPR WSHR BLK M8	
216	010-P00408-F	S-TITE SCR PH W/F M4 X 8	
301	FRI-6103	ASSY WIRE COCKPIT D	
302	FRI-6104	ASSY WIRE COCKPIT AC	
303	600-6972-1250	WIRE HARN EARTH ID5 1250MM	

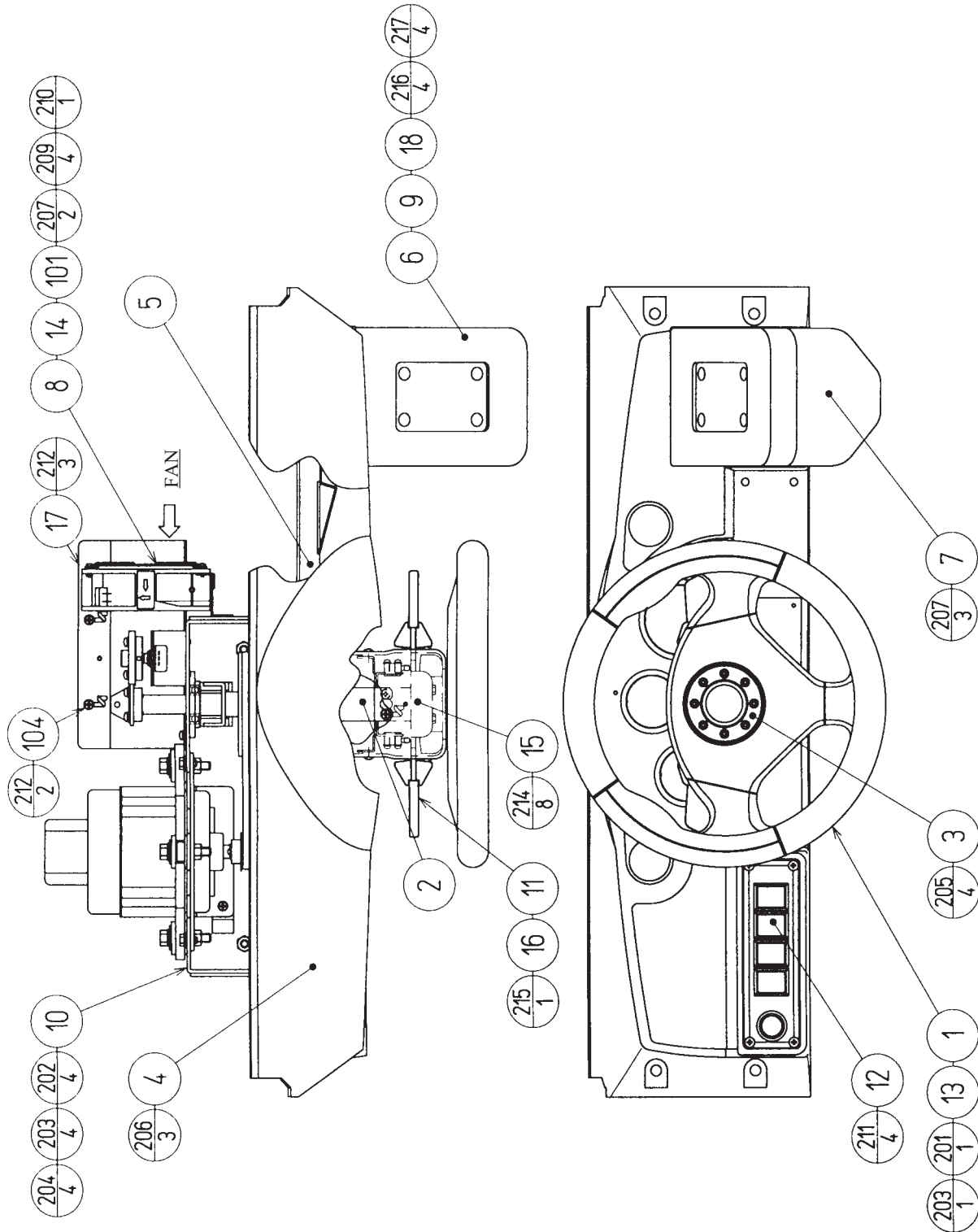

⑩ ASSY CONTROL PANEL TWIN EXP (FRI-12001-01)

(D-2/3)

ITEM NO.	PART NO.	DESCRIPTION	NOTE
1	SPG-2001	STEERING WHEEL	
2	FRI-1203	HANDLE COLLAR	
3	FRI-2002	STEERING EMBLEM FRI	
4	FRI-1201-01	CONTROL PANEL COVER ENG	
5	FRI-1202	CONTROL PANEL BRKT	
6	INY-1204	SHIFT COVER INY	
7	DYN-1223X	SHIFT COVER B	
8	SPG-1203	FAN BRKT	
9	LMN-1202	SHIFT BASE	
10	FRI-2550	ASSY HANDLE MECHA	
11	FRI-2600	ASSY PADDLE SHIFT TWIN	
12	FRI-1290	ASSY EFECT SW TWIN	
13	SPG-2039	SPACER RING	
14	601-8543	FAN GUARD	
15	FRI-2055	BOSS COVER	
16	DYN-1270	STOPPER KEY	
17	FRI-1204	WIRE GUIDE	
18	FRI-1212	SHIFT COVER LID	
101	260-0011-02	AXIAL FLOW FAN AC100V 50-60HZ	
102	601-0460	PLASTIC TIE BELT 100 MM	
103	280-5009-01	CORD CLAMP 21	
104	280-0419	HARNESS LUG	
105	280-5275-SR10	CORD CLAMP SR10	
106	211-5361-08YE	CONN PLUG U-POWER 08P-YE	
201	020-000830-0Z	HEX SKT H CAP SCR BLK OZ M8 X 30	
202	060-F00800	FLT WSHR M8	
203	060-S00800	SPR WSHR M8	
204	050-H00800	HEX NUT M8	
205	FAS-200013	HEX SKT H CAP SCR CRM M4 X 16	
206	000-T00416-0B	M SCR TH BLK M4 X 16	
207	000-P00412-W	M SCR PH W/FS M4 X 12	
208	000-T00412-0B	M SCR TH BLK M4 X 12	
209	000-P00312-W	M SCR PH W/FS M3 X 12	
210	050-F00300	FLG NUT M3	
211	000-T00412-0C	M SCR TH CRM M4 X 12	
212	000-P00408-W	M SCR PH W/FS M4 X 8	
213	010-P00406-F	S-TITE SCR PH W/F M4 X 6	
214	000-T00408-0B	M SCR TH BLK M4 X 8	
215	028-A00408-P	SET SCR HEX SKT CUP P M4 X 8	
216	000-P00520-W	M SCR PH W/FS M5 X 20	
217	030-000820-S	HEX BLT W/S M8 X 20	
218	050-F00400	FLG NUT M4	

⑩ ASSY CONTROL PANEL TWIN EXP (FRI-12001-01)

(D-3/3)

ITEM NO.	PART NO.	DESCRIPTION	NOTE
301	600-6873-043	WIRE HARN VIEW BUTTON	
302	600-6873-047	WIRE HARN CONT PNL FAN	
303	600-6873-050	WIRE HARN EXT VOLUME C	
304	600-6972-0130	WIRE HARN EARTH ID5 0130MM	
305	600-7064-027	WIRE HARN EXT ENCODER B	
306	600-7064-028	WIRE HARN EXT MOTOR B	
307	FRI-61062	WIRE HARN VMS	
310	600-6972-0200	WIRE HARN EARTH ID5 0200MM	

⑪ VM UNIT FRI (FRI-1250)

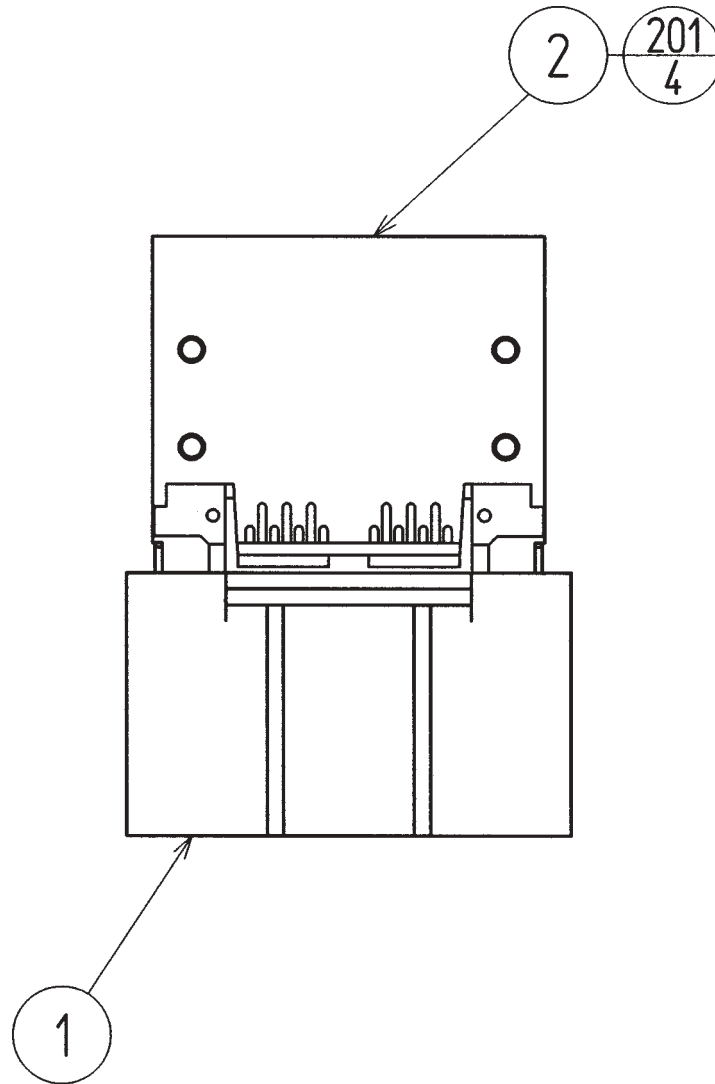

ITEM NO.	PART NO.	DESCRIPTION	NOTE
1	NOA-1901	VM GUIDE	
2	839-1132	MAPLE/LM CONVERT BD W/VM SKT	
201	012-P00306	TAP SCR #2 PH 3 X 6	

⑫ ASSY EFECT SW TWIN (FRI-1290)

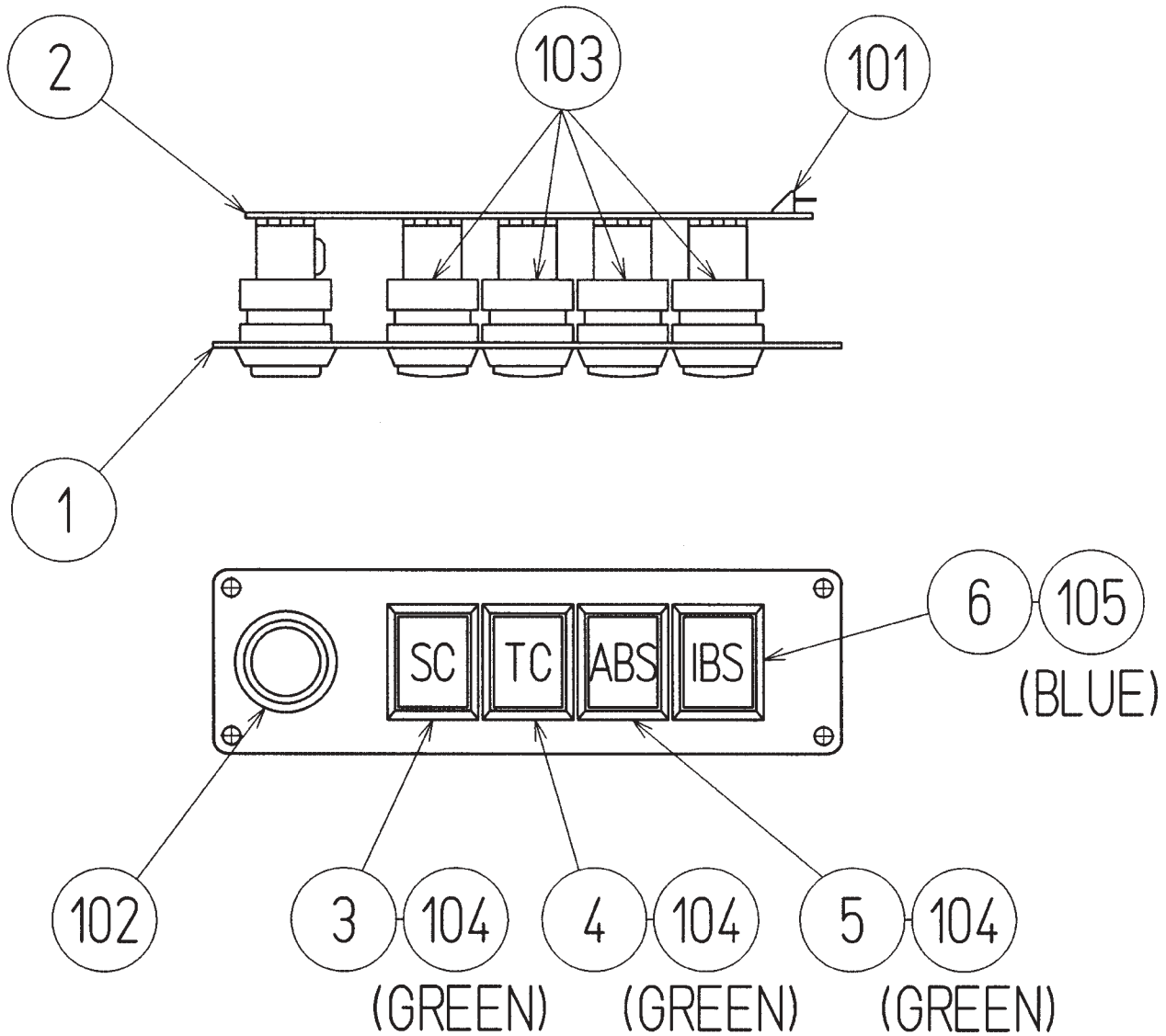

ITEM NO.	PART NO.	DESCRIPTION	NOTE
1	DYN-1291	VR BUTTON BRKT	
2	171-6478B	PC BD LIGHTING SWX5	
3	FRI-1291	BUTTON SHEET SC FRI TWIN	
4	FRI-1292	BUTTON SHEET TC FRI TWIN	
5	FRI-1293	BUTTON SHEET ABS FRI TWIN	
6	FRI-1294	BUTTON SHEET IBS FRI TWIN	
101	212-5205-12	CONN JST M 12P RTA	
102	509-5560-Y	PB SW W/L 6V 1L Y	
103	509-5485	PB W/L 6V W/O LEN,PLT 5L	
104	253-5383-02	BUTTON COVER 5L GR	
105	253-5383-04	BUTTON COVER 5L BL	

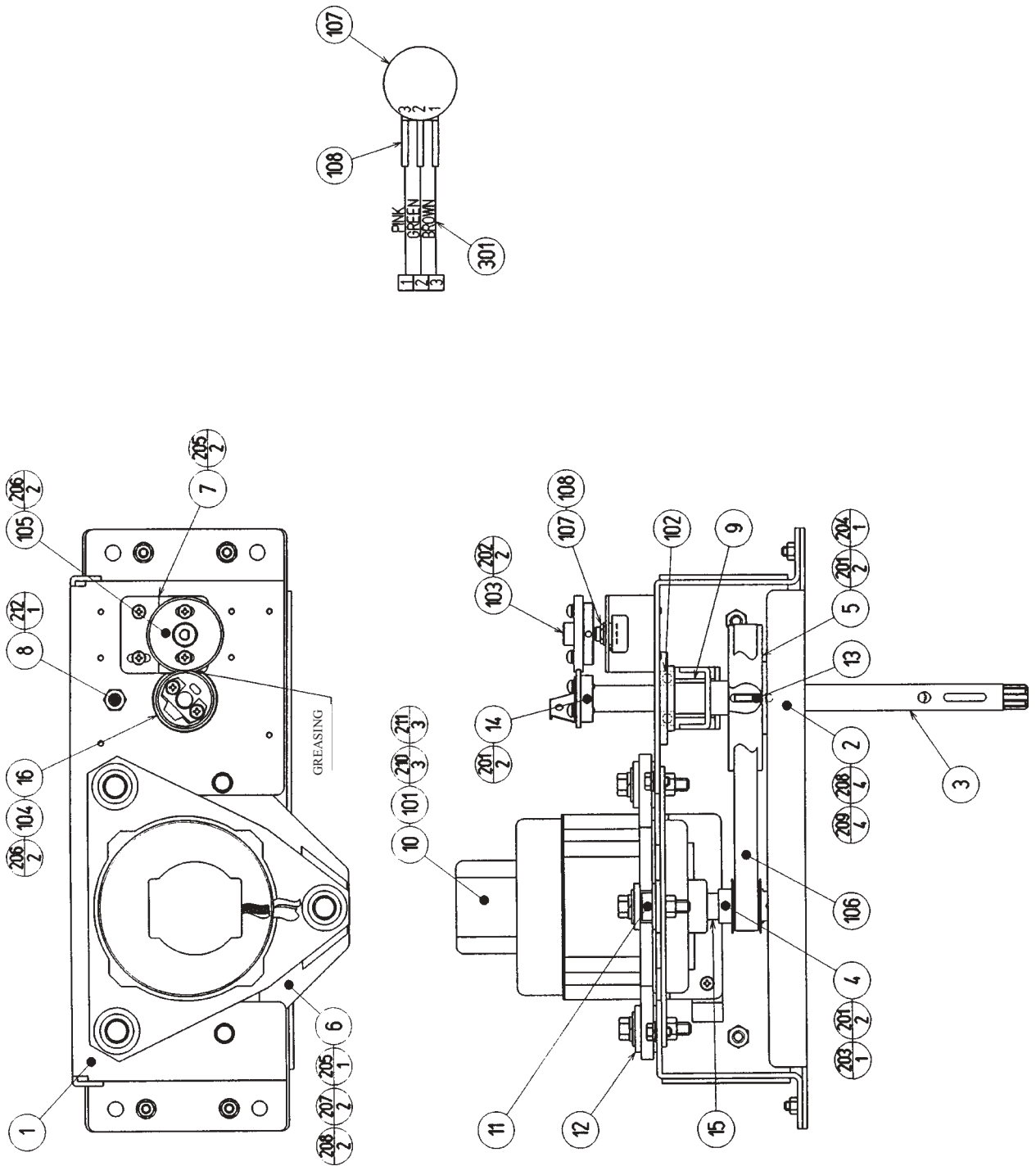

13 ASSY HANDLE MECHA (FRI-2550)

(D-2/2)

ITEM NO.	PART NO.	DESCRIPTION	NOTE
1	SPG-2501X	HANDLE BASE	
2	SPG-2502	BASE LID	
3	FRI-2551	HANDLE SHAFT	
4	SPG-2504	PULLEY 20 S5M	
5	SPG-2505	PULLEY 60 S5M	
6	SPG-2506	MOTOR BRKT	
7	SPG-2507	VR BRKT	
8	SPG-2108	STOPPER BOLT	
9	SPG-2109	STOPPER RUBBER	
10	SPG-2453	KEY 4 X 4 X 40	
11	ASK-3502	MOTOR SPACER	
12	ASK-3503	MOTOR COLLAR	
13	DYN-1270	STOPPER KEY	
14	SLC-1130	ADJUST RING	
15	SPG-2454	MOTOR SHAFT COLLAR	
16	SLC-1108	WIRE HOLDER	
101	350-5448-01	SERVO MOTOR 500W NEW	
102	100-5112	BEARING 17	
103	601-8966	GEAR HOLDER	
104	601-6172	GEAR 48	
105	601-6959	GEAR 64	
106	601-9173	TIMING BELT (150 S5M 475)	
107	220-5484	VOL CONT B-5K OHM	
	220-5373	VOL CONT B-5K	
108	310-5029-F20	SUMITUBE F F 20MM	
109	270-5117	FERRITE CORE TDK ZCAT3035-1330	
110	601-0460	PLASTIC TIE BELT 100 MM	
111	280-0419	HARNESS LUG	
201	028-A00408-P	SET SCR HEX SKT CUP P M4 X 8	
202	028-A00308-P	SET SCR HEX SKT CUP P M3 X 8	
203	065-S012S0-Z	STP RING BLK OZ S12	
204	065-S020S0-Z	STP RING BLK OZ S20	
205	000-P00408-W	M SCR PH W/FS M4 X 8	
206	000-P00412-W	M SCR PH W/FS M4 X 12	
207	030-000612-S	HEX BLT W/S M6 X 12	
208	060-F00600	FLT WSHR M6	
209	050-U00600	U NUT M6	
210	030-000840-S	HEX BLT W/S M8 X 40	
211	068-852216	FLT WSHR 8.5-22 X 1.6	
212	050-U00800	U NUT M8	
301	600-6866	WIRE HARN ASSY HANDLE MECHA VR	



14 ASSY PADDLE SHIFT TWIN (FRI-2600)

(D-1/2)

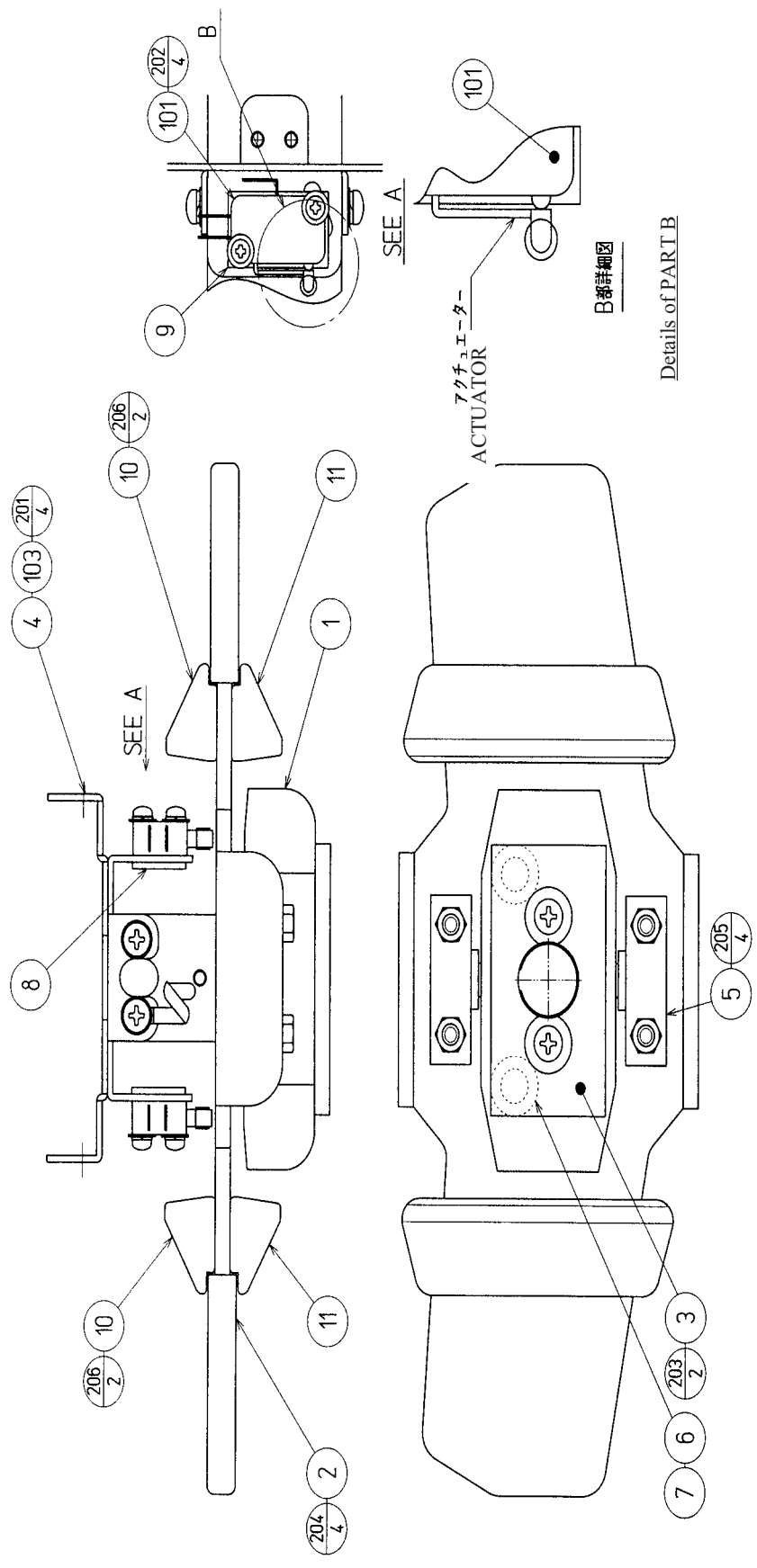

⑭ ASSY PADDLE SHIFT TWIN (FRI-2600)

(D-2/2)

ITEM NO.	PART NO.	DESCRIPTION	NOTE
1	FRI-2601	BOSS TWIN	
2	FRI-2052	SHIFT PLATE	
3	FRI-2603	SPRING LID TWIN	
4	FRI-2602	SW BRKT TWIN	
5	SLC-1314	PIVOT	
6	SLC-1315X	PLUNGER	
7	SLC-1316	COMP SPRING	
8	117-0141	PLATE LOCK	
9	310-0012	PAPER INSL	
10	FRI-2056X	GUARD BLOCK A	
11	FRI-2057X	GUARD BLOCK B	
101	509-5387	SW MICRO TYPE	
102	280-5275-SR10	CORD CLAMP SR10	
103	280-0419	HARNESS LUG	
104	601-0460	PLASTIC TIE BELT 100 MM	
201	000-P00408-S	M SCR PH W/S M4 X 8	
202	000-P00316-W	M SCR PH W/FS M3 X 16	
203	000-F00512	M SCR FH M5 X 12	
204	000-F00525	M SCR FH M5 X 25	
205	050-U00500	U NUT M5	
206	012-P00416	TAP SCR #2 PH 4 X 16	
301	FRI-61063	WIRE HARN PADDLE SHIFT	
302	FRI-61065	WIRE HARN PADDLE GND	

15) ASSY BASE BOX (FRI-1500)

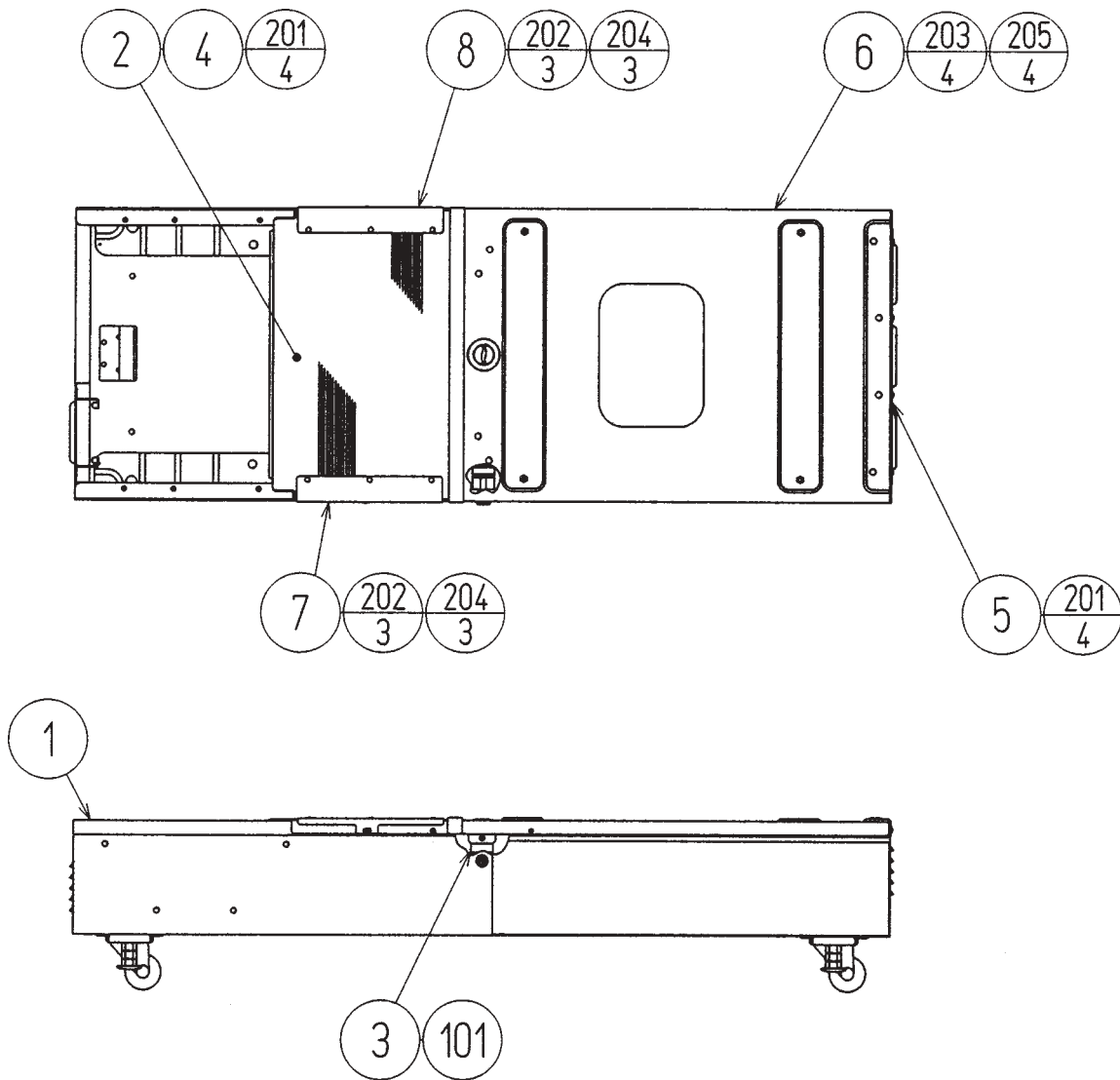

ITEM NO.	PART NO.	DESCRIPTION	NOTE
1	FRI-1501	MAIN BASE	
2	DYN-2003	BASE LID F	
3	DYN-2004	LOCK TNG	
4	DYN-2005X	FLOOR MAT	
5	DYN-2006	HINGE 480	
6	FRI-1510	ASSY BASE LID R	
7	DYN-2007X	LID EDGE L	
8	DYN-2009X	LID EDGE R	
101	220-5575	CAM LOCK MASTER W/O KEY	
201	000-T00512-0B	M SCR TH BLK M5 X 12	
202	031-000414-0C	CRG BLT CRM M4 X 14	
203	031-000514-0B	CRG BLT BLK M5 X 14	
204	050-F00400	FLG NUT M4	
205	050-F00500	FLG NUT M5	

16 ASSY BASE LID R (FRI-1510)

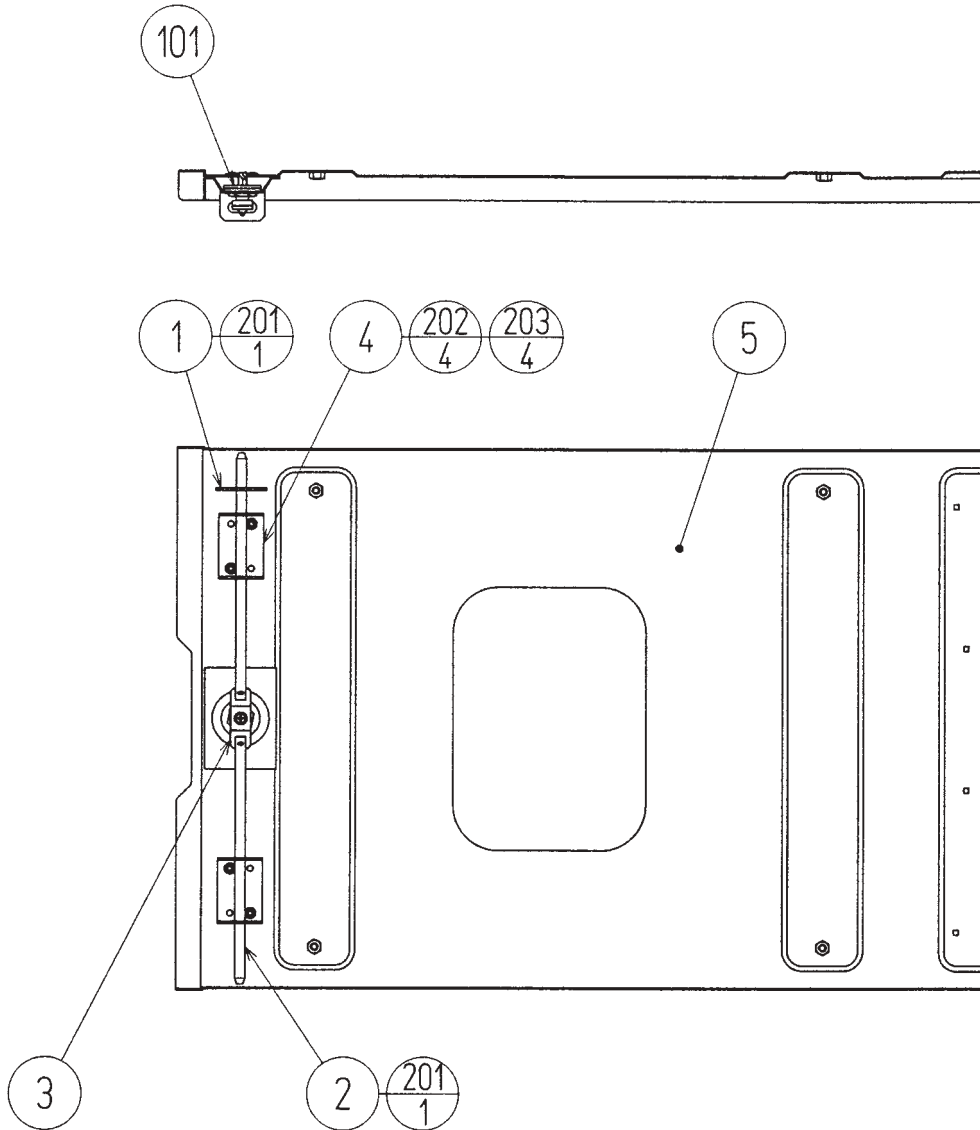

ITEM NO.	PART NO.	DESCRIPTION	NOTE
1	DYN-2011	LOCK ROD A	
2	DYN-2012	LOCK ROD B	
3	DYN-2013	LOCK ARM	
4	DYN-2014	ROD HOLDER	
5	FRI-1511	BASE LID R	
101	601-7551	LOCK HANDLE	
102	601-5526-170	BUSH 1.6T (L=170)	
103	280-5008	CORD CLAMP 15	
201	045-C02520	COT PIN 2.5 X 20	
202	031-000510-0B	CRG BLT BLK M5 X 10	
203	050-F00500	FLG NUT M5	

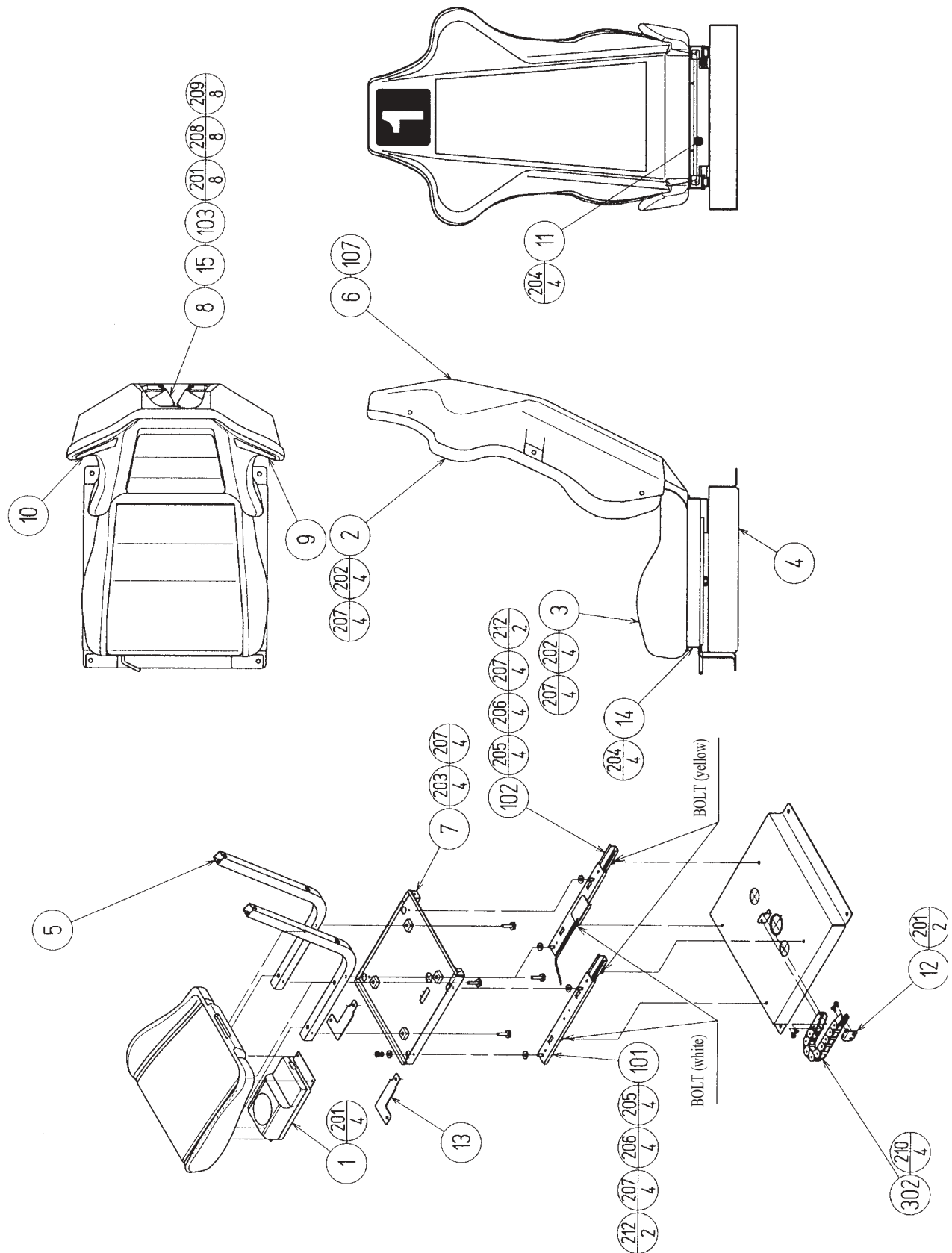

17 ASSY SEAT TWIN 1P (FRI-1600)

(D-2/2)

ITEM NO.	PART NO.	DESCRIPTION	NOTE
1	STC-1650	ASSY WOOFER	
2	FRI-3302	UPPER SEAT	
3	FRI-3303	LOWER SEAT	
4	STC-2201	SEAT BASE	
5	STC-1604	SEAT FRAME	
6	FRI-1601	SEAT REAR COVER 1P	
7	STC-1606X	SEAT MOUNT TRAY	
8	STC-1607	SP MOUNT BRKT	
9	STC-1608	SPEAKER NET L	
10	STC-1609	SPEAKER NET R	
11	STC-1610	SAFETY GUARD	
12	STC-1611	CABLE BEAR BRKT	
13	STC-1612	PROTECT RUBBER	
14	STC-1613	SAFETY GUARD F	
15	INY-1302-B	MASK CUSHION SIDE	
101	601-9059-91	SEAT RAIL L	
102	601-9060-91	SEAT RAIL R	
103	130-5159	GULL BOX SPEAKER 8OHM 5W	
104	280-5009-01	CORD CLAMP 21	
105	601-6563-188	BUSH 2.4T	
106	601-6563-100	BUSH 2.4T	
107	280-5297	SCRIVET 8 1K31	
108	280-5275-SR10	CORD CLAMP SR10	
201	000-P00410-W	M SCR PH W/FS M4 X 10	
202	030-000845-S	HEX BLT W/S M8 X 45	
203	030-000816-S	HEX BLT W/S M8 X 16	
204	000-T00408-0B	M SCR TH BLK M4 X 8	
205	050-H00800	HEX NUT M8	
206	060-S00800	SPR WSHR M8	
207	068-852216	FLT WSHR 8.5-22 X 1.6	
208	012-P00412	TAP SCR #2 PH 4 X 12	
209	060-F00400	FLT WSHR M4	
210	000-T00616-0B	M SCR TH BLK M6 X 16	
212	060-F01000	FLT WSHR M10	
301	600-6774-016	WIRE HARN SPEAKER EXT	
302	600-6774-017	WIRE HARN SEAT EXT	

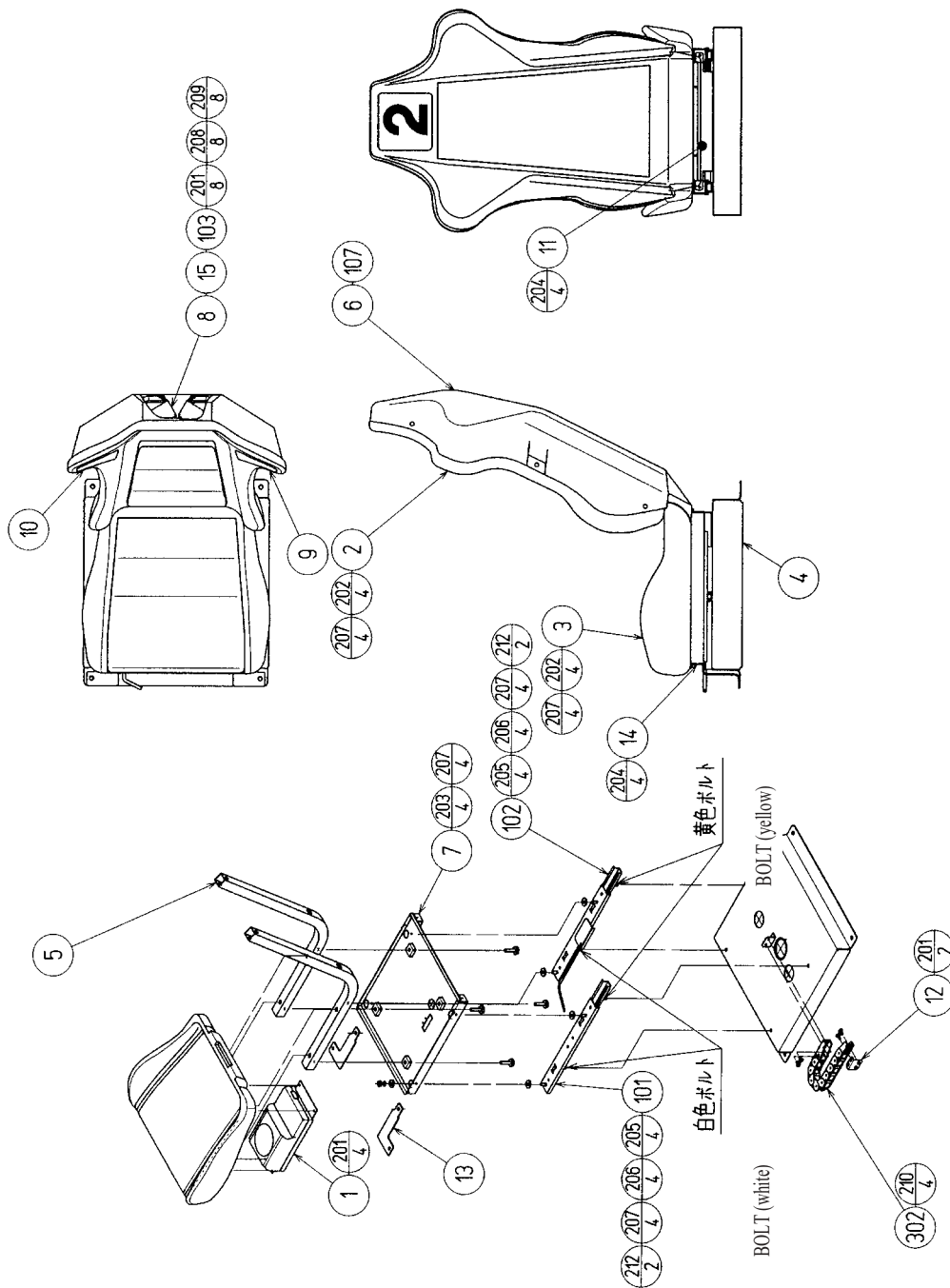

18 ASSY SEAT TWIN 2P (FRI-1700)

(D-2/2)

ITEM NO.	PART NO.	DESCRIPTION	NOTE
1	STC-1650	ASSY WOOFER	
2	FRI-3302	UPPER SEAT	
3	FRI-3303	LOWER SEAT	
4	STC-2201	SEAT BASE	
5	STC-1604	SEAT FRAME	
6	FRI-1701	SEAT REAR COVER 2P	
7	STC-1606X	SEAT MOUNT TRAY	
8	STC-1607	SP MOUNT BRKT	
9	STC-1608	SPEAKER NET L	
10	STC-1609	SPEAKER NET R	
11	STC-1610	SAFETY GUARD	
12	STC-1611	CABLE BEAR BRKT	
13	STC-1612	PROTECT RUBBER	
14	STC-1613	SAFETY GUARD F	
15	INY-1302-B	MASK CUSHION SIDE	
101	601-9059-91	SEAT RAIL L	
102	601-9060-91	SEAT RAIL R	
103	130-5159	GULL BOX SPEAKER 8OHM 5W	
104	280-5009-01	CORD CLAMP 21	
105	601-6563-188	BUSH 2.4T	
106	601-6563-100	BUSH 2.4T	
107	280-5297	SCRIVET 8 1K31	
108	280-5275-SR10	CORD CLAMP SR10	
201	000-P00410-W	M SCR PH W/FS M4 X 10	
202	030-000845-S	HEX BLT W/S M8 X 45	
203	030-000816-S	HEX BLT W/S M8 X 16	
204	000-T00408-0B	M SCR TH BLK M4 X 8	
205	050-H00800	HEX NUT M8	
206	060-S00800	SPR WSHR M8	
207	068-852216	FLT WSHR 8.5-22 X 1.6	
208	012-P00412	TAP SCR #2 PH 4 X 12	
209	060-F00400	FLT WSHR M4	
210	000-T00616-0B	M SCR TH BLK M6 X 16	
212	060-F01000	FLT WSHR M10	
301	600-6774-016	WIRE HARN SPEAKER EXT	
302	600-6774-017	WIRE HARN SEAT EXT	



①9 ASSY WOOFER (STC-1650)

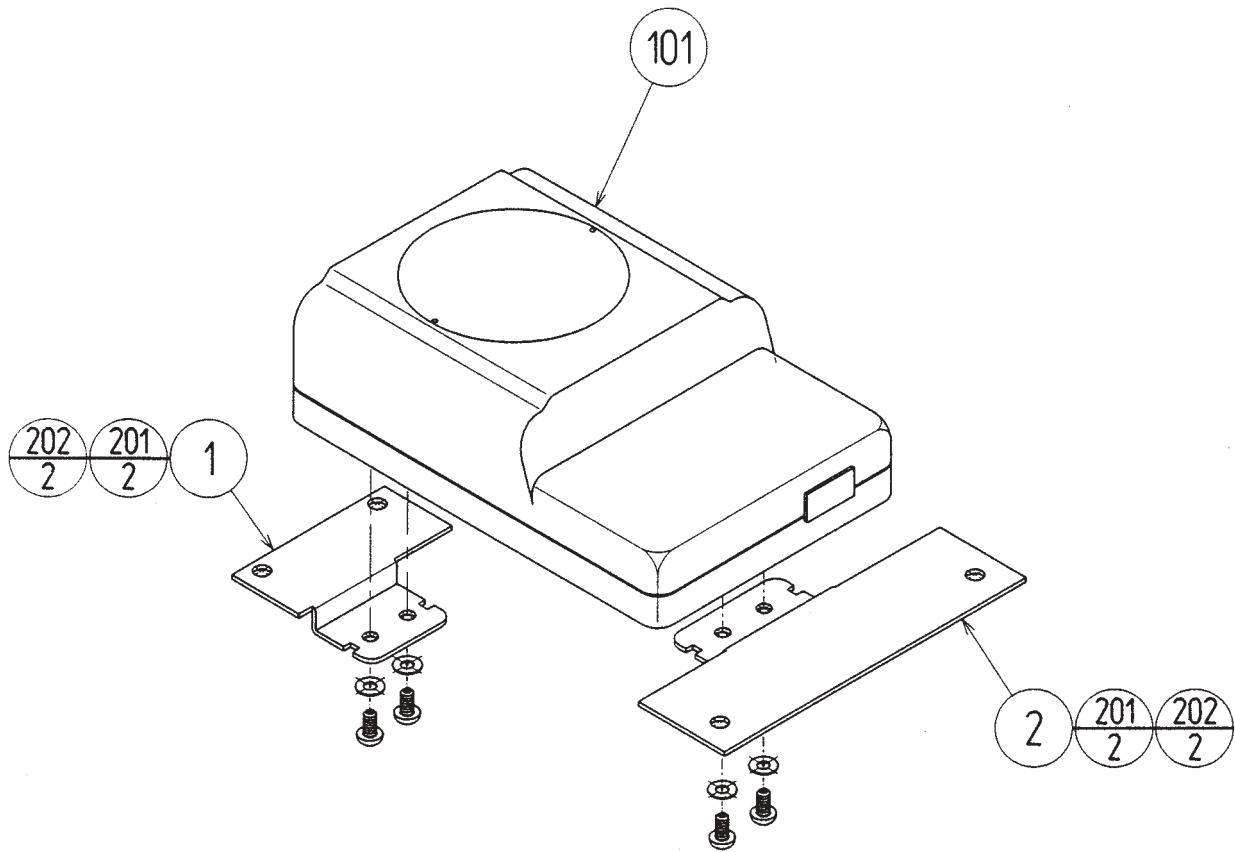

ITEM NO.	PART NO.	DESCRIPTION	NOTE
1	STC-1651	WOOFER BRKT F	
2	STC-1652	WOOFER BRKT R	
101	130-5160	SUB WOOFER 4OHM 30W	
201	012-P00412	TAP SCR #2 PH 4 X 12	
202	060-F00400	FLT WSHR M4	

20 ASSY MAIN BASE 1P (FRI-20001)

(D-1/2)

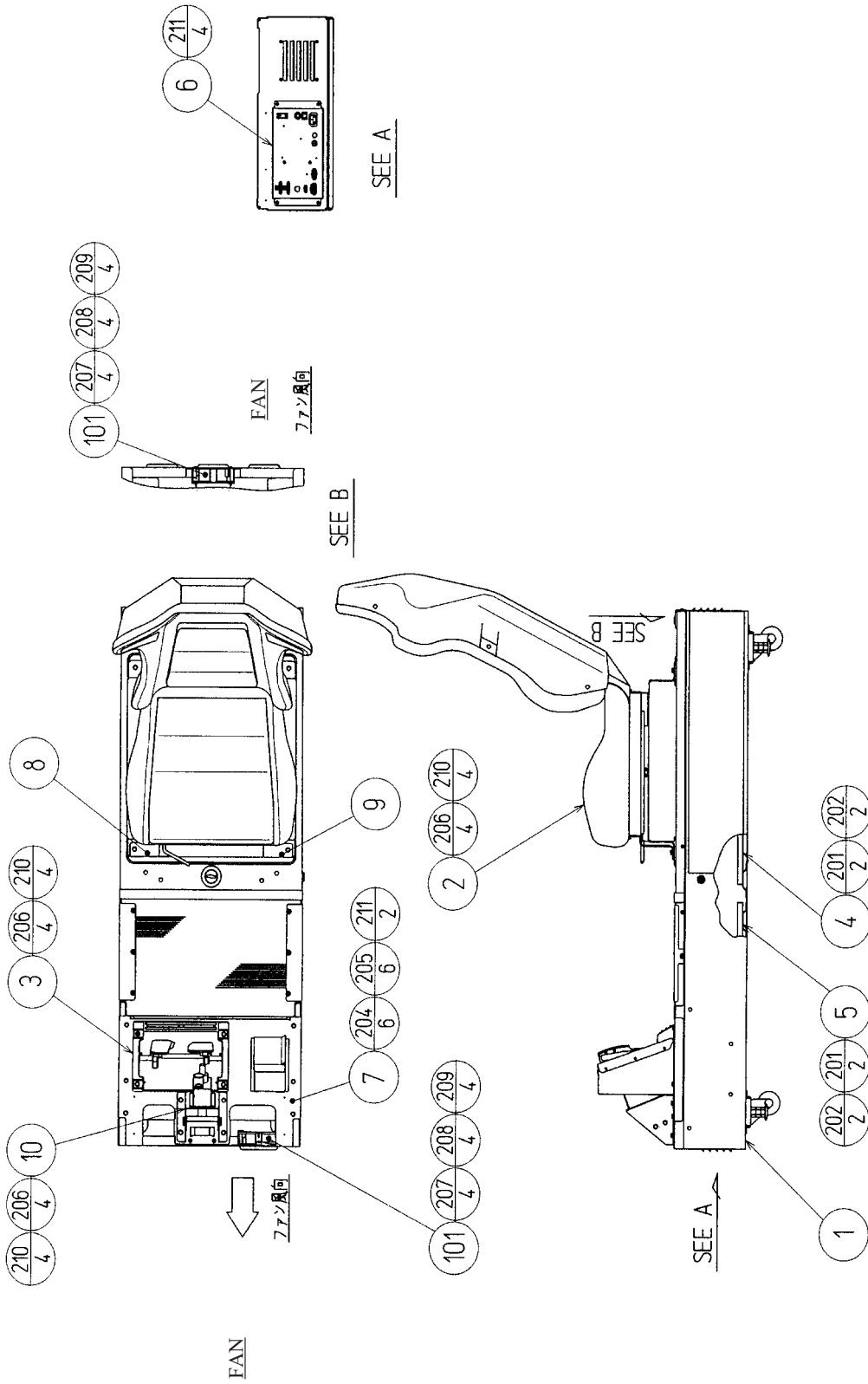

②0 ASSY MAIN BASE 1P (FRI-20001)

(D-2/2)

ITEM NO.	PART NO.	DESCRIPTION	NOTE
1	FRI-1500	ASSY BASE BOX	
2	FRI-1600	ASSY SEAT TWIN 1P	
3	FRI-2250	ASSY ACCEL&BRAKE	
4	FRI-4500	ASSY MAIN BD BASE	
5	FRI-4600	ASSY ELEC BASE	
6	FRI-0400	AC UNIT MAIN	
7	FRI-1502	PEDAL BASE FRI	
8	RAL-2007	RUBBER HOLDER R TWIN	
9	RAL-2008	RUBBER HOLDER L TWIN	
10	FRI-2350	ABSORBER UNIT TWIN	
101	260-0011-02	AXIAL FLOW FAN AC100V 50-60HZ	
102	600-6275-0150	ASSY FIBER CABLE 5 0150CM	
	600-6275-0140	ASSY FIBER CABLE 5 0140CM	
103	280-5009-01	CORD CLAMP 21	
104	280-5275-SR10	CORD CLAMP SR10	
105	280-5169	CORD CLAMP TL-20S	
201	000-P00425-W	M SCR PH W/FS M4 X 25	
202	068-441616	FLT WSHR 4.4-16 X 1.6	
203	050-F00500	FLG NUT M5	
204	030-000616-SB	HEX BLT W/S BLK M6 X 16	
205	060-F00600-0B	FLT WSHR BLK M6	
206	060-F00800-0B	FLT WSHR BLK M8	
207	000-P00350	M SCR PH M3 X 50	
208	060-S00300	SPR WSHR M3	
209	060-F00300	FLT WSHR M3	
210	030-000825-SB	HEX BLT W/S BLK M8 X 25	
211	000-P00408-WB	M SCR PH W/FS BLK M4 X 8	
301	600-6972-0150	WIRE HARN EARTH ID5 0150MM	
313	600-7009-2500	ASSY RGB CA D-SUB 15P 2500MM	
314	FRI-6101	ASSY WIRE MAIN BASE DC	
315	FRI-6102	ASSY WIRE MAIN BASE AC	



②1 ASSY MAIN BASE 2P (FRI-21001)

(D-2/2)

ITEM NO.	PART NO.	DESCRIPTION	NOTE
1	FRI-1500	ASSY BASE BOX	
2	FRI-1700	ASSY SEAT TWIN 2P	
3	FRI-2250	ASSY ACCEL&BRAKE	
4	FRI-4500	ASSY MAIN BD BASE	
5	FRI-4600	ASSY ELEC BASE	
6	FRI-0700	AC UNIT SUB	
7	FRI-1502	PEDAL BASE FRI	
8	RAL-2007	RUBBER HOLDER R TWIN	
9	RAL-2008	RUBBER HOLDER L TWIN	
10	FRI-2350	ABSORBER UNIT TWIN	
101	260-0011-02	AXIAL FLOW FAN AC100V 50-60HZ	
102	600-6275-0150	ASSY FIBER CABLE 5 0150CM	
	600-6275-0140	ASSY FIBER CABLE 5 0140CM	
103	280-5009-01	CORD CLAMP 21	
104	280-5275-SR10	CORD CLAMP SR10	
105	280-5169	CORD CLAMP TL-20S	
201	000-P00425-W	M SCR PH W/FS M4 X 25	
202	068-441616	FLT WSHR 4.4-16 X 1.6	
203	050-F00500	FLG NUT M5	
204	030-000616-SB	HEX BLT W/S BLK M6 X 16	
205	060-F00600-0B	FLT WSHR BLK M6	
206	060-F00800-0B	FLT WSHR BLK M8	
207	000-P00350	M SCR PH M3 X 50	
208	060-S00300	SPR WSHR M3	
209	060-F00300	FLT WSHR M3	
210	030-000825-SB	HEX BLT W/S BLK M8 X 25	
211	000-P00408-WB	M SCR PH W/FS BLK M4 X 8	
301	600-6972-0150	WIRE HARN EARTH ID5 0150MM	
313	600-7009-2500	ASSY RGB CA D-SUB 15P 2500MM	
314	FRI-6101	ASSY WIRE MAIN BASE DC	
315	FRI-6102	ASSY WIRE MAIN BASE AC	

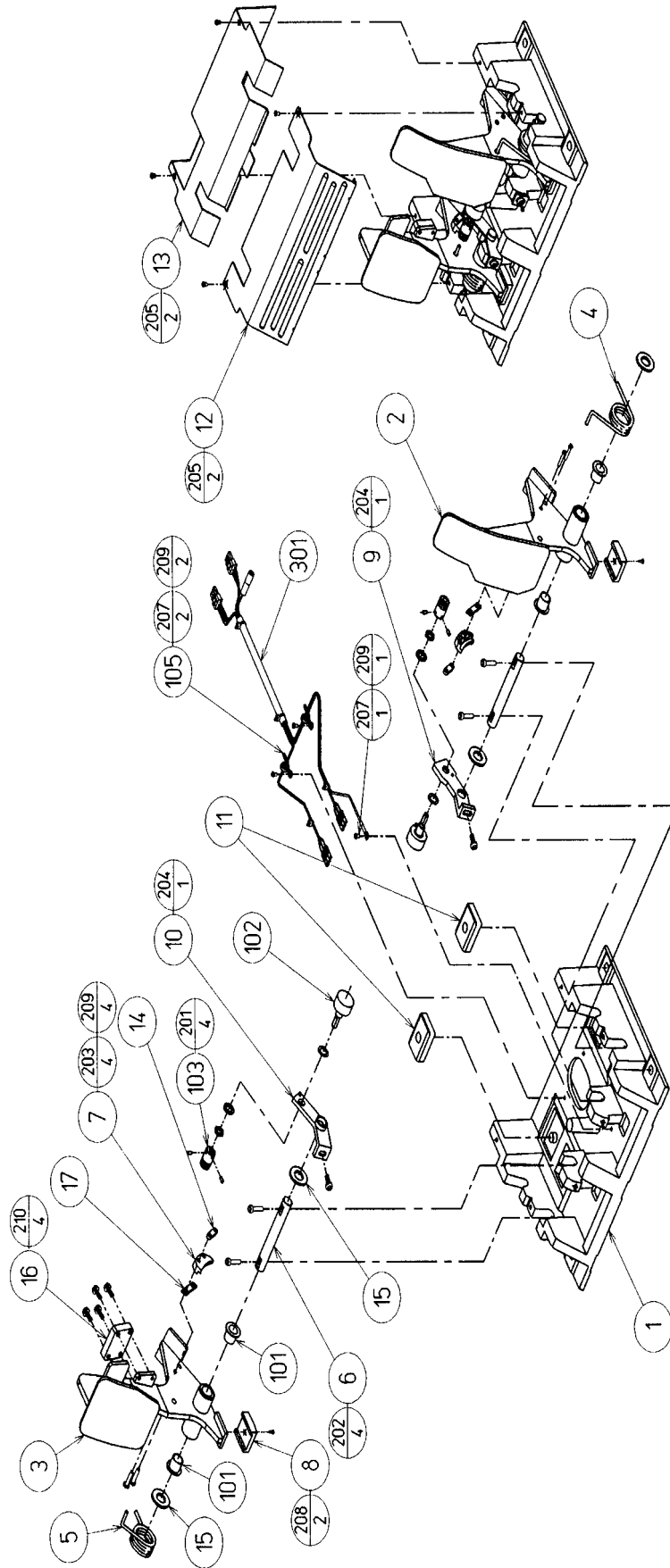

22 ASSY ACCEL & BRAKE (FRI-2250)

(D-2/2)

ITEM NO.	PART NO.	DESCRIPTION	NOTE
1	SPG-2201	BASE	
2	FRI-2251	ACCEL PEDAL FRI	
3	FRI-2252	BRAKE PEDAL FRI	
4	FRI-2257	ACCEL SPRING FRI	
5	FRI-2253	BRAKE SPRING FRI	
6	SPG-2206	SHAFT	
7	SPG-2207	ACCEL GEAR	
8	FRI-2254	NEUTRAL STOPPER FRI	
9	SPG-2210	VR PLATE ACCEL	
10	FRI-2255	VR PLATE BRAKE FRI	
11	SPG-2214	STOPPER	
12	SPG-2216	COVER	
13	FRI-2256	VR COVER FRI	
14	SPG-2219	GEAR STAY	
15	SPG-2220	WSHR	
16	FRI-2258	STOPPER PLATE	
17	FRI-2259	GEAR SPACER	
101	100-5263	BEARING 12	
102	220-5484	VOL CONT B-5K OHM	
103	601-7944	GEAR 15	
104	310-5029-F15	SUMITUBE F F 15MM	
105	280-0419	HARNESS LUG	
201	028-A00304-P	SET SCR HEX SKT CUP P M3 X 4	
202	020-000520-0Z	HEX SKT H CAP SCR BLK M5 X 20	
203	000-P00420	M SCR PH M4 X 20	
204	000-P00508-W	M SCR PH W/FS M5 X 8	
205	000-T00408-0C	M SCR TH CRM M4 X 8	
206	FAS-450005	SPR PIN BLK OZ 6 X 10	
207	000-P00405	M SCR PH M4 X 5	
208	FAS-000001	M SCR TH CRM M3 X 6	
209	060-F00400	FLT WSHR M4	
210	000-P00412-W	M SCR PH W/FS M4 X 12	
301	FRI-60088	WIRE HARN ACCEL&BRAKE	

23) ABSORBER UNIT TWIN (FRI-2350)

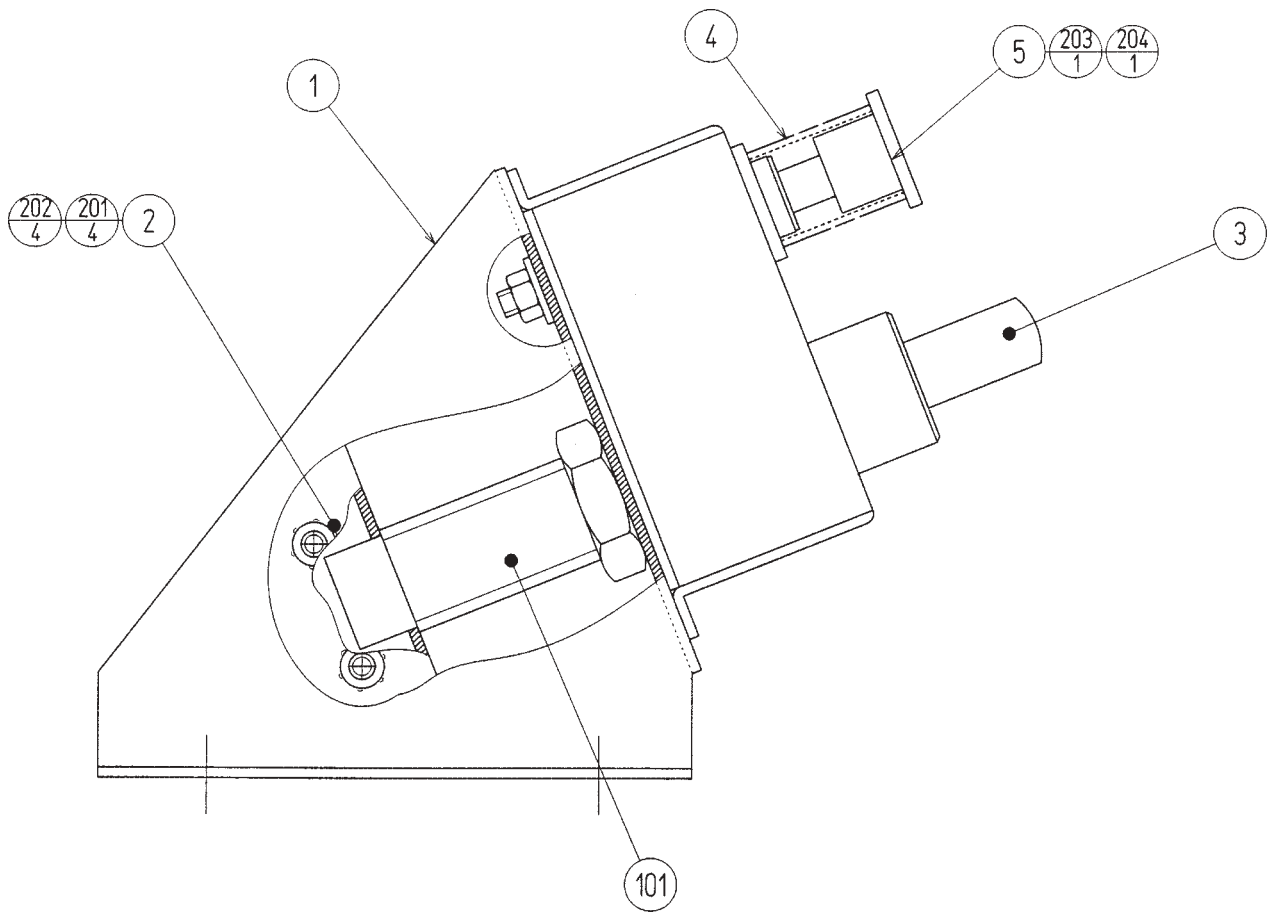

ITEM NO.	PART NO.	DESCRIPTION	NOTE
1	FRI-2351	ABSORBER BRKT TWIN	
2	FRI-2352	ABSORBER SUB BRKT TWIN	
3	FRI-2303	PLUNGER	
4	FRI-2305	COMP SPRING FRI	
5	FRI-2306	STOPPER SHAFT	
101	601-10662	SHOCK ABSORBER W/O CAP	
201	030-000825-SB	HEX BLT W/S BLK M8 X 25	
202	060-F00800-0B	FLT WSHR BLK M8	
203	050-U00600	U NUT M6	
204	068-652016	FLT WSHR 6.5-20 X 1.6	



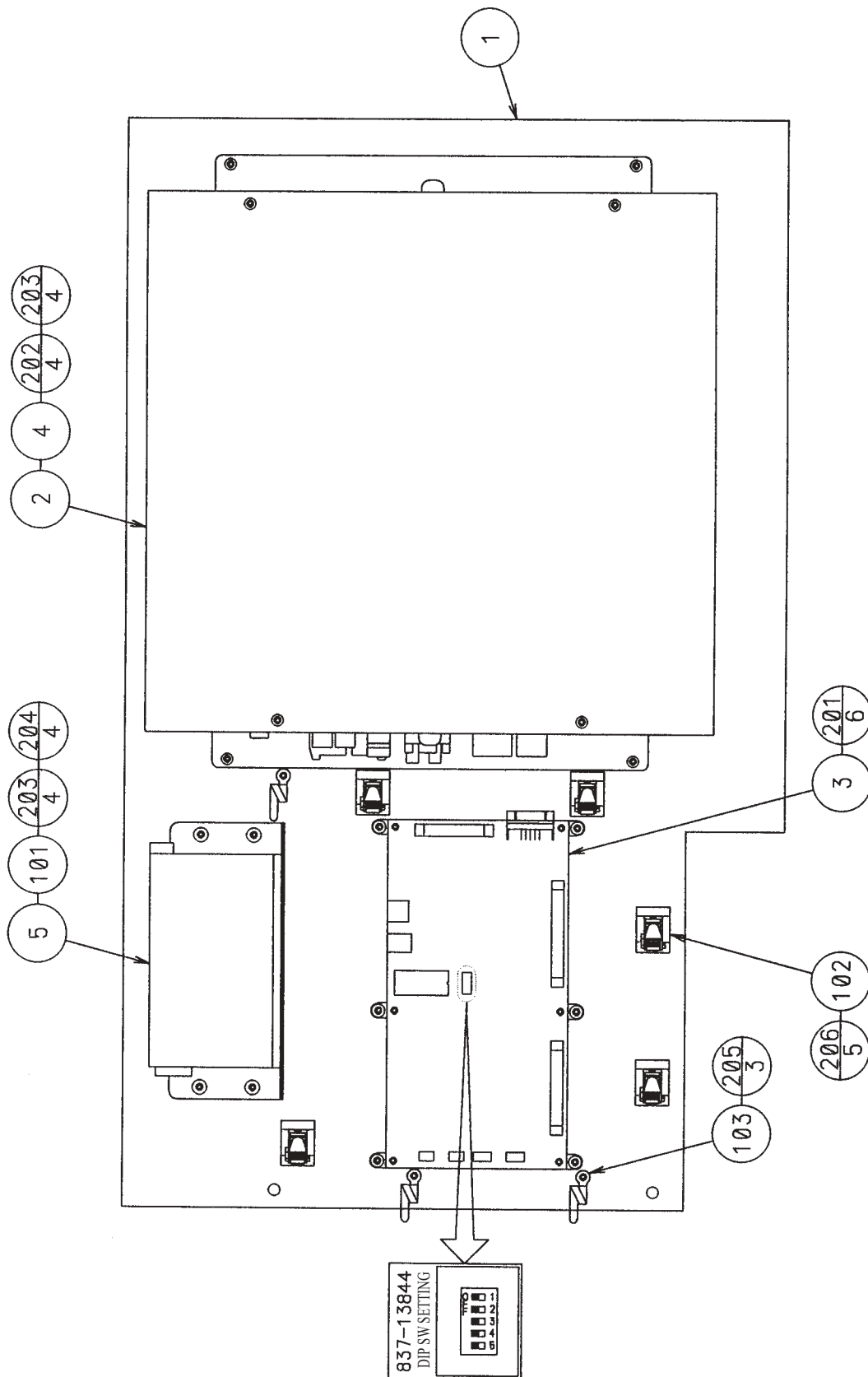

24 ASSY MAIN BD BASE (FRI-4500)

(D-2/2)

ITEM NO.	PART NO.	DESCRIPTION	NOTE
1	FRI-4501	WOODEN BASE MAIN	
2	FRI-4550-01	ASSY SHIELD CASE USA	USA
	FRI-4550-02	ASSY SHIELD CASE EXP	OTHERS
	FRI-4550-03	ASSY SHIELD CASE KOR	KOREA
	FRI-4550-04	ASSY SHIELD CASE AUS	AUSTRALIA
3	837-13844	I/O CONTROL BD 2 FOR JVS FRI	
4	105-5368	SHIELD CASE BRKT	
5	APC-4002	SW REGU BRKT	
101	400-5397-01	SW REGU FOR JVS VA	
102	280-5009-01	CORD CLAMP 21	
103	280-0419	HARNESS LUG	
104	601-0460	PLASTIC TIE BELT 100 MM	
201	011-T00316	TAP SCR TH 3 X 16	
202	000-P00408-W	M SCR PH W/FS M4 X 8	
203	000-P00412-W	M SCR PH W/FS M4 X 12	
204	000-P00406-W	M SCR PH W/FS M4 X 6	
205	011-T03512	TAP SCR TH 3.5 X 12	
206	011-F00310	TAP SCR FH 3 X 10	
301	FRI-61015	WIRE HARN MAIN VMS	
302	FRI-61016	WIRE HARN MAIN AUDIO	
303	FRI-61017	WIRE HARN I/O BD DC IN	
304	FRI-61018	WIRE HARN I/O BD A/D	
305	FRI-61019	WIRE HARN I/O BD	
306	600-7159-060	WIRE HARN JVS PWR 060CM	
307	600-7141-050	CABLE JVS TYPE A-B 050CM	

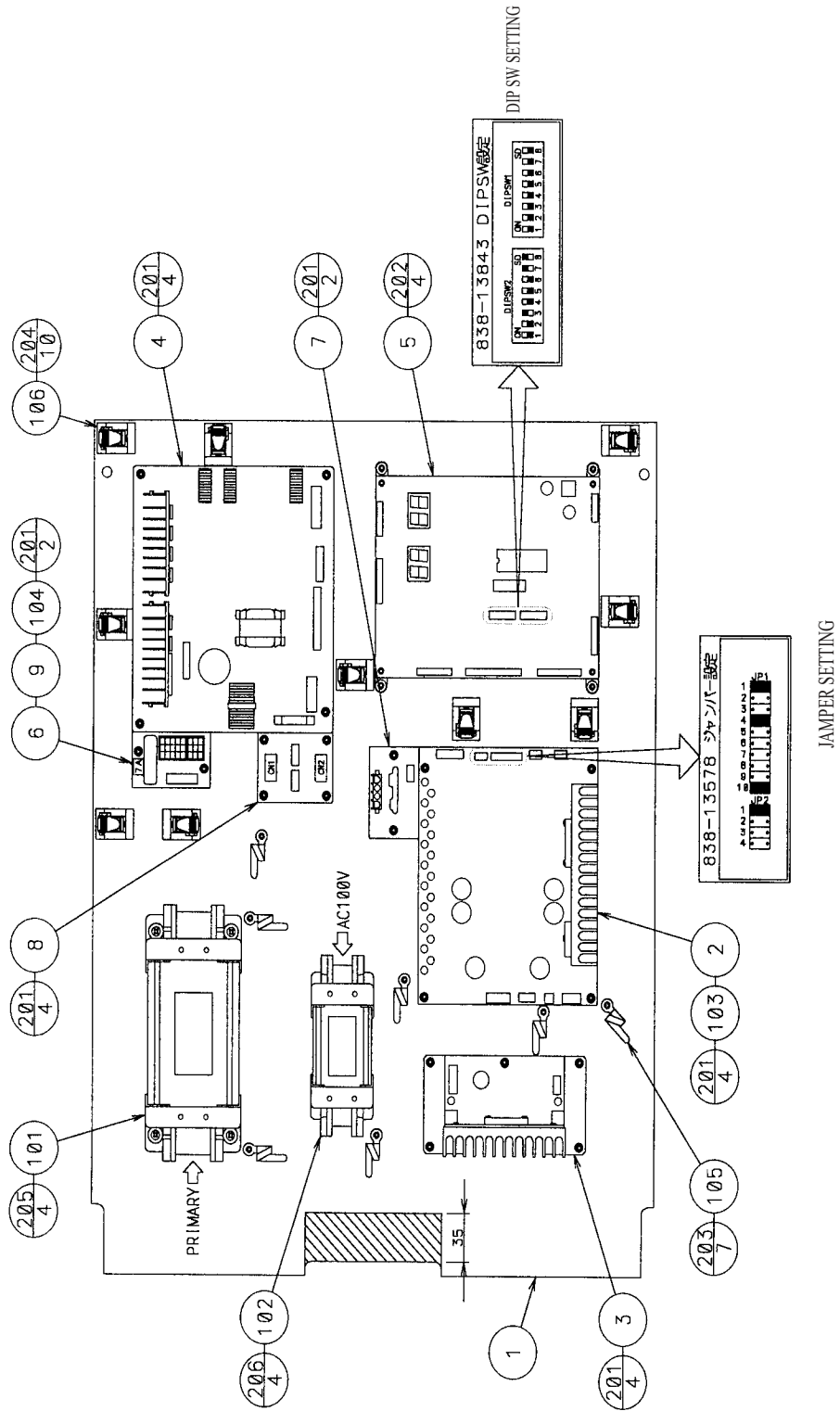

ITEM NO.	PART NO.	DESCRIPTION	NOTE
1	FRI-4601	WOODEN BASE ELEC	
2	838-13578	PWR AMP 2CH & MIXER	
3	838-11651-01	LOWPASS AMP W/LARGE HEAT SINK	
4	838-12912-01	SERVO MOTOR DRIVE BD NEW	
5	838-13843	DRIVE BD FRI	
6	838-11856-01-UL	CONNECT BD W/FUSE & COVER UL	
7	839-1148	4A DC SSR BD NH4P	
8	839-1151	CAPACITOR BD	
9	421-6595-11	STICKER 7A	
101	560-5434-V	XFMR 100-120V 100V7.5A	AC 100V AREA
	560-5435-V	XFMR 220-240V 100V7.5A CE	AC 220 ~ 240V AREA
102	560-5405-V	XFMR 100V 14V6.3A	
103	211-5305	C JMPR SCKT (IMSA-9206H-GF)	
104	514-5036-7000	FUSE 6.4 X 30 7000MA 125V	
105	280-0419	HARNESS LUG	
106	280-5009-01	CORD CLAMP 21	
107	601-0460	PLASTIC TIE BELT 100 MM	
108	270-5117	FERRITE CORE TDK ZCAT3035-1330	
201	011-T00325	TAP SCR TH 3 X 25	
202	011-T00316	TAP SCR TH 3 X 16	
203	011-T03512	TAP SCR TH 3.5 X 12	
204	011-F00310	TAP SCR FH 3 X 10	
205	000-P00512-W	M SCR PH W/FS M5 X 12	
206	000-P00412-W	M SCR PH W/FS M4 X 12	
301	FRI-61001	WIRE HARN CONN BD IN	
302	FRI-61002	WIRE HARN CONN BD OUT A	
303	FRI-61003	WIRE HARN CONN BD B	
304	FRI-61004	WIRE HARN M.DRIVE BD AC100V	
305	FRI-61005	WIRE HARN AC14V	
306	FRI-61006	WIRE HARN AMP SPEAKER	
307	FRI-61007	WIRE HARN AMP AUDIO	
308	FRI-61008	WIRE HARN AMP VR	
309	FRI-61009	WIRE HARN AMP TO AMP	
310	FRI-61010	WIRE HARN DRIVE BD	
311	FRI-61011	WIRE HARN SSR BD SIG	
312	FRI-61012	WIRE HARN M.DRIVE BD ENCODER	
313	FRI-61013	WIRE HARN TX & RX	
314	FRI-61014	WIRE HARN DRIVE BD DC IN	

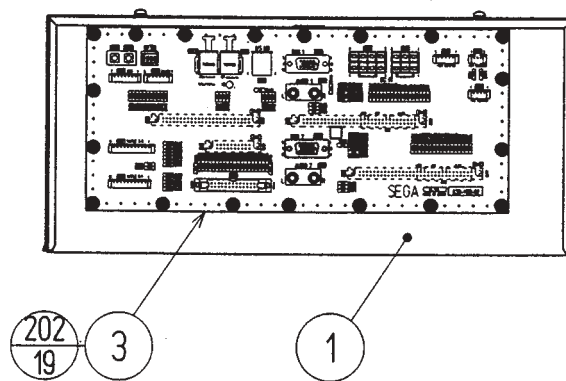
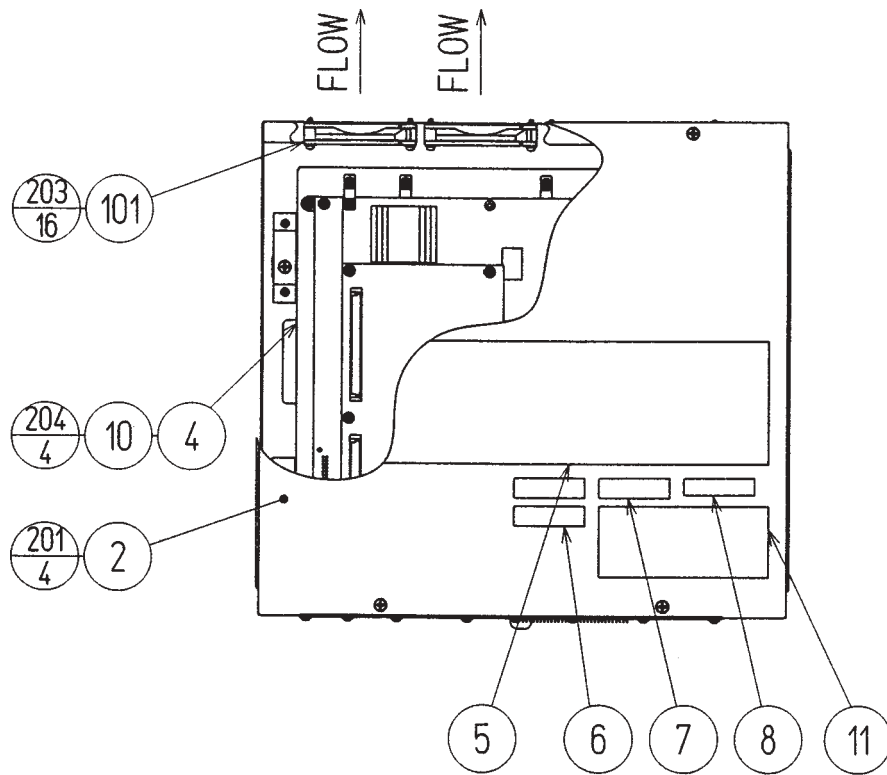

②6 ASSY SHIELD CASE ~ (FRI-4550 ~)

(D-2/2)

ITEM NO.	PART NO.	DESCRIPTION	NOTE
1	105-5413	SHIELD CASE NAOMI MULTI 2	
2	105-5414	SHIELD CASE LID NAOMI MULTI 2	
3	839-1109-02	FLT BD NAOMI MULTI MASTER FRI	
4	833-13949- ~	GAME BD FRI TWIN ~	
5	421-9174-01	STICKER CAUTION ANTISTATIC	
6	421-10023-AAA	STICKER BD SERIAL NUMBER AAA	
7	421-10023-BBA	STICKER BD SERIAL NUMBER BBA	
8	441-313949- ~	STICKER 833-13949- ~	
9	601-10835	CARTON BOX NAOMI MULTI 2	
10	105-5390	FIXING BRACKET	
11	421-10094	STICKER ONLY JAPAN	
101	260-0064	FAN MOTOR DC12V	
102	280-5275-SR10	CORD CLAMP SR10	
201	000-P00408-W	M SCR PH W/FS M4 X 8	
202	010-P00308-F	S-TITE SCR PH W/F M3 X 8	
203	000-P00320-W	M SCR PH W/FS M3 X 20	
204	000-P00412-W	M SCR PH W/FS M4 X 12	
301	APC-60046	WIRE HARN FAN MOTOR SLAVE	

# 21. WIRE COLOR CODE TABLE

THE WIRE COLOR CODE is as follow:

- A PINK
- B SKY BLUE
- C BROWN
- D PURPLE
- E LIGHT GREEN

Wires other than those of any of the above 5 single colors will be displayed by 2 alphanumeric characters.

- 1 RED
- 2 BLUE
- 3 YELLOW
- 4 GREEN
- 5 WHITE
- 7 ORANGE
- 8 BLACK
- 9 GRAY

If the right-hand side numeral of the code is 0, then the wire will be of a single color shown by the left-hand side numeral (see the above).

Note 1: If the right-hand side alphanumeric is not 0, that particular wire has a spiral color code. The left-hand side character shows the base color and the right-hand side one, the spiral color.

<Example> 51 ..... WHITE / RED

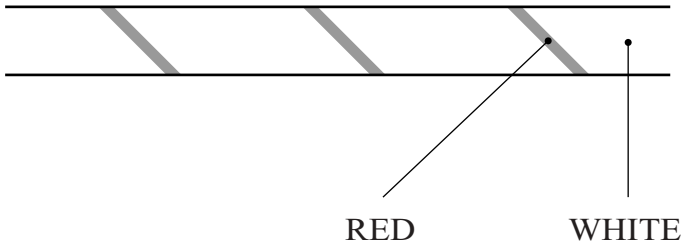

Note 2: The character following the wire color code indicates the size of the wire.

- U: AWG16, UL1015
- K: AWG18, UL1015
- L: AWG20, UL1007
- None: AWG22, UL1007

## **Warranty**

Your new Sega Product is covered for a period of 90 days from the date of shipment. This certifies that the Printed Circuit Boards, Power Supplies and Monitor are to be free of defects in workmanship or materials under normal operating conditions. This also certifies that all Interactive Control Assemblies are to be free from defects in workmanship and materials under normal operating conditions. No other product in this machine is hereby covered.

Sellers sole liability in the event a warranted part described above fails shall be, at its option, to replace or repair the defective part during the warranty period. For Warranty claims, contact your Sega Distributor.

Should the Seller determine, by inspection that the product was caused by Accident, Misuse, Neglect, Alteration, Improper Repair, Installation or Testing, the warranty offered will be null and void.

Under no circumstances is the Seller responsible for any loss of profits, loss of use, or other damages.

This shall be the exclusive written Warranty of the original purchaser expressed in lieu of all other warranties expressed or implied. Under no circumstance shall it extend beyond the period of time listed above.





**SEGA ENTERPRISES, INC. (USA)**

45133 Industrial Drive  
Fremont, CA 94538  
**(415) 701-6580** phone  
**(415) 701-6594** fax