

This document has been downloaded from:



The largest resource for amusement machines
documentation on the world wide web!



FLIPPERSPILL.COM

namco[®]

FINAL FURLONG 2

CONVERSION INSTRUCTIONS

It is **most important** that the game is tested and any problems rectified before any conversion work is started.

Please make a note of all setting values so that the new Game PCB can be set accordingly.

Warning: Ensure that the game is switched off and disconnected from the mains supply before any conversion work is started.

Caution: Ensure adequate space is available to be able to remove the header safely.

Note: Take care when removing items not to lose any screws and washers as they may be required for reassembly.

Tools Required:-

No1 Pozi Driver

No2 Pozi Driver

Security Wrench for M5

Spanner for M10

Spanner for M20

Security Torx Wrench for M5 (Supplied in kit)

PRELIMINARY

Removing the Ride Assembly

1. Raise the twelve adjustable feet, (4 on the monitor cabinet and 4 on each ride base assy), (Slacken the lock nuts with a spanner first.)

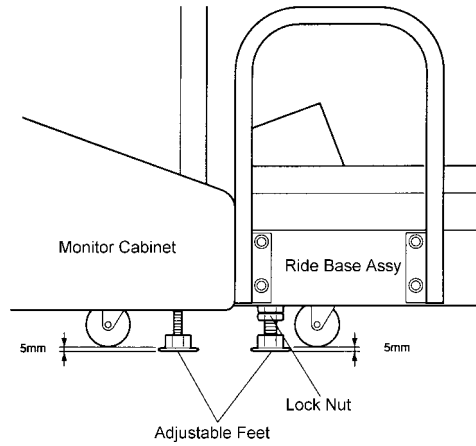

2. Remove 8 off security screws (M5x12) and remove both Base Front Cover Plates.

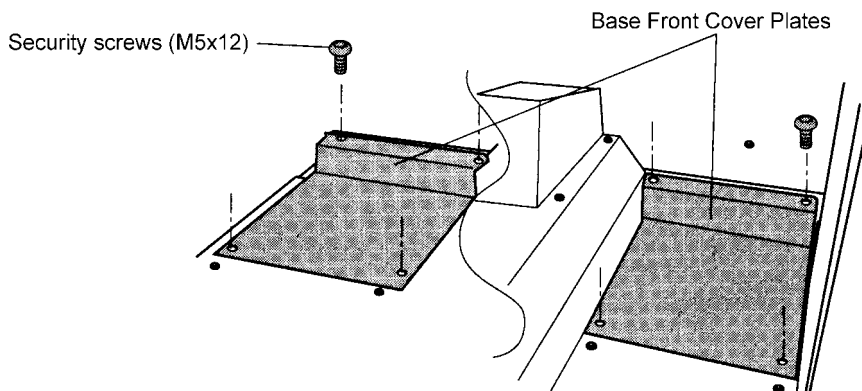

3. Remove 4 off hex head screws (M10x35), with flat and spring washers, retaining the ride base to the monitor cabinet.

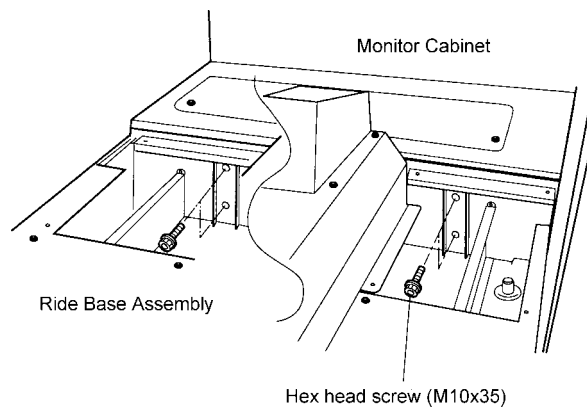

4. Pull the ride assembly away from the monitor cabinet only sufficient to reach the connectors. (*Take care not to stretch the wiring harness.*)

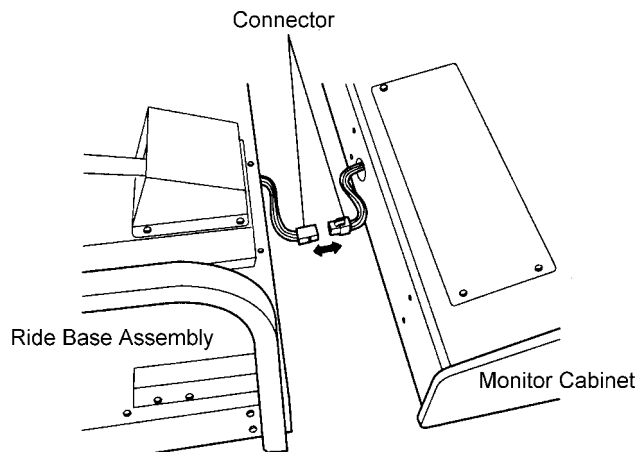

5. Disconnect the connectors and move the ride assembly completely away from the monitor cabinet.

Removing the Header Assembly

The header assembly is high and has a forward centre of gravity, so it is important that at least two people are used to remove or fit the Header Assembly.

1. Remove 2 off pozi head screws (M4x12), with flat and spring washers, and remove the connector cover plate.

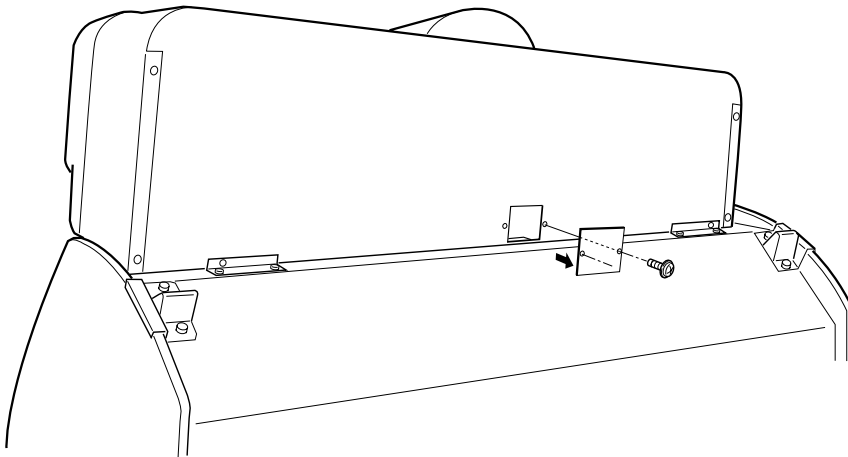

2. Disconnect the connector.

3. Remove 2 off pozi head screws (M5x16), with flat and spring washers.

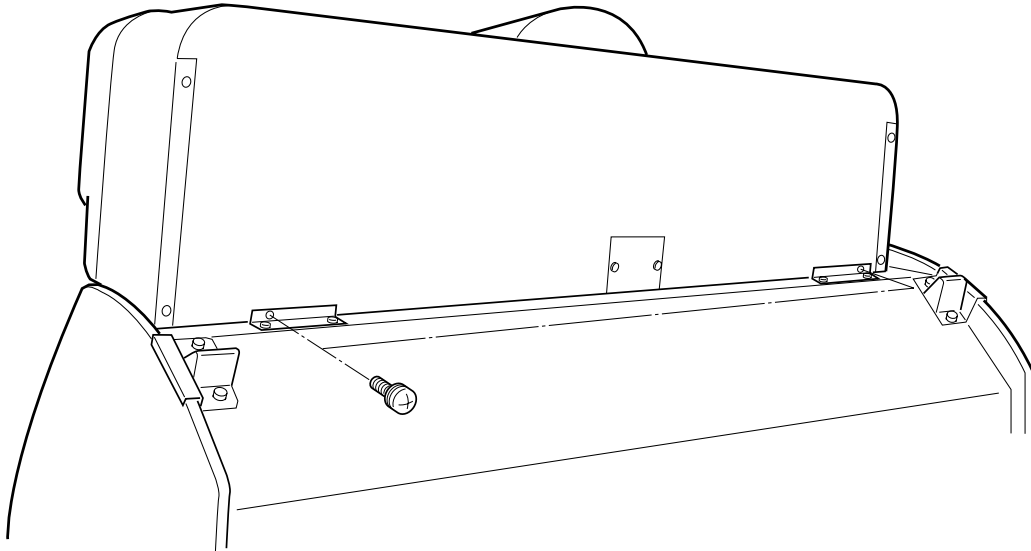

4. Slide the header assembly forward so that it disengages with the retaining bracket.

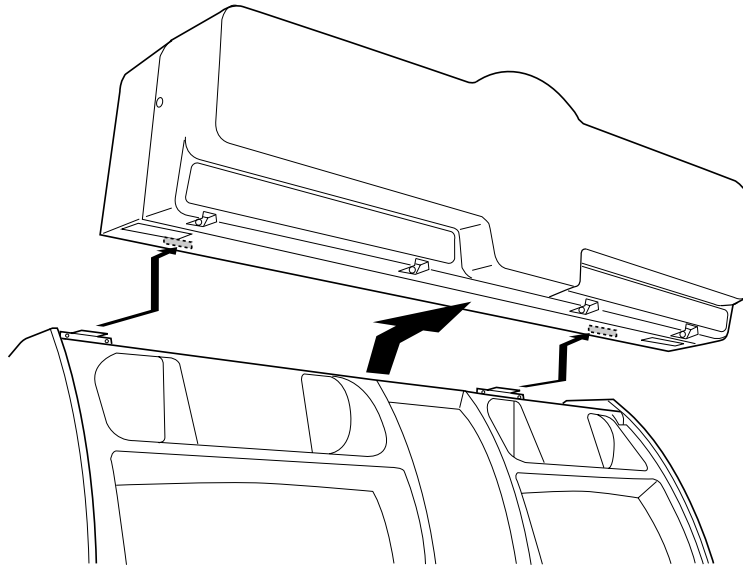

5. Remove the Header Assembly

RIDE ASSEMBLY

DECALS

1. Remove the Horse Rear Decals (both sides of the horse).
2. Fit the new Horse Rear Decals (both sides of the horse).
3. Fit the new decals to the rear of the Ride Base.

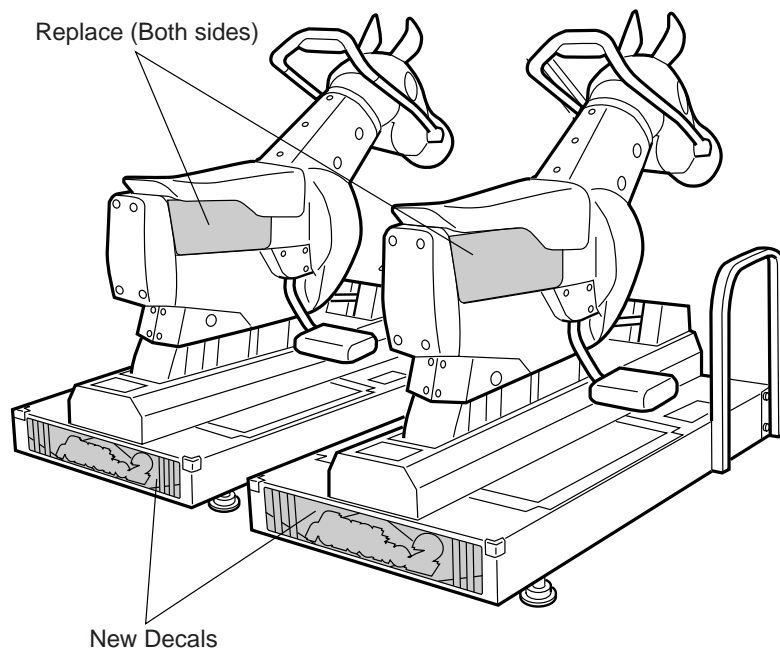

HEADER ASSEMBLY

- 1. Remove the ten security screws (M5x16) and remove the header acrylic. (This part is no longer required).

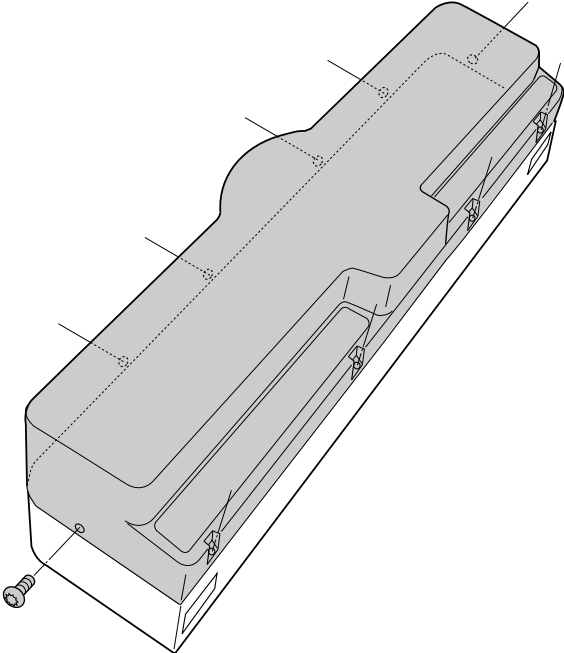

- 2. Remove 2 off pozi head screw (M4x12) and remove the Top Bracket. (This part is no longer required).

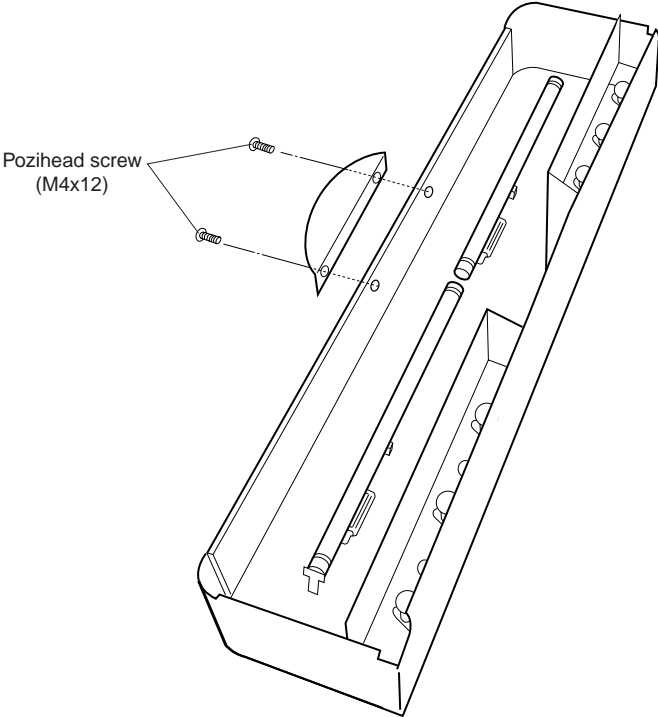

3. Fit the **new** top brackets with 4off torx security screws (M5x12 black), supplied.

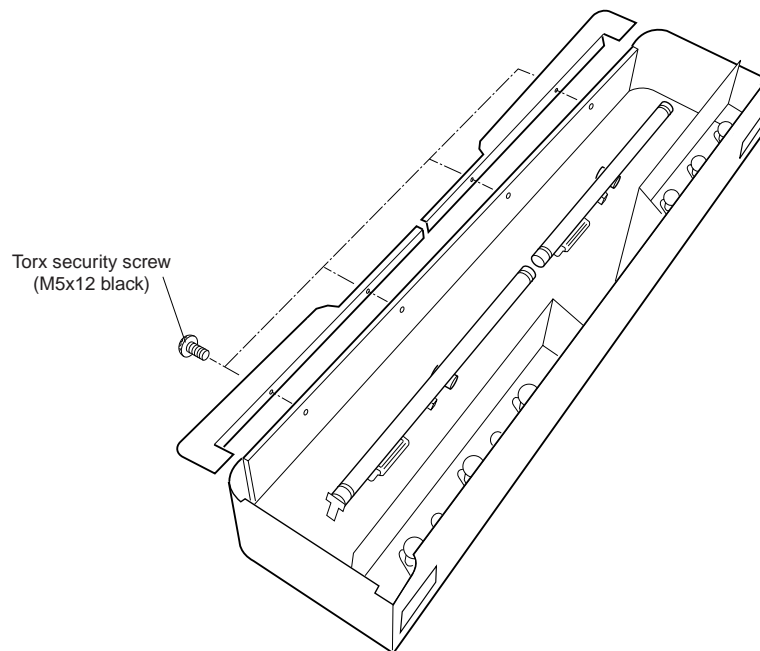

4. Fit the **new** Header Acrylic with 10off torx security screw (M5x16 chrome), supplied.

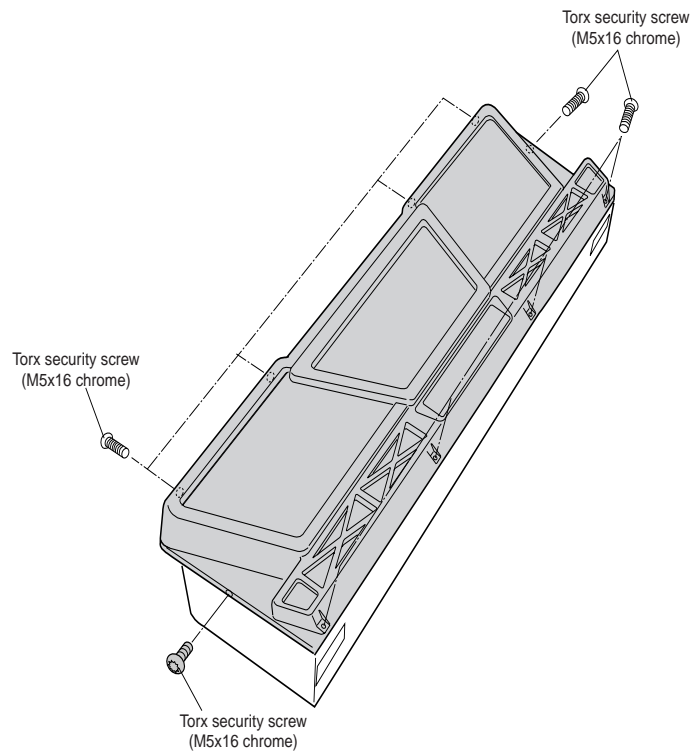

5. Refit the Header Assembly.
6. Reconnect the connector.
7. Refit the Connector Cover Plate.

MONITOR CABINET

Replacing the Decals

1. Remove all the old decals, except the Monitor Middle Lower Decal.

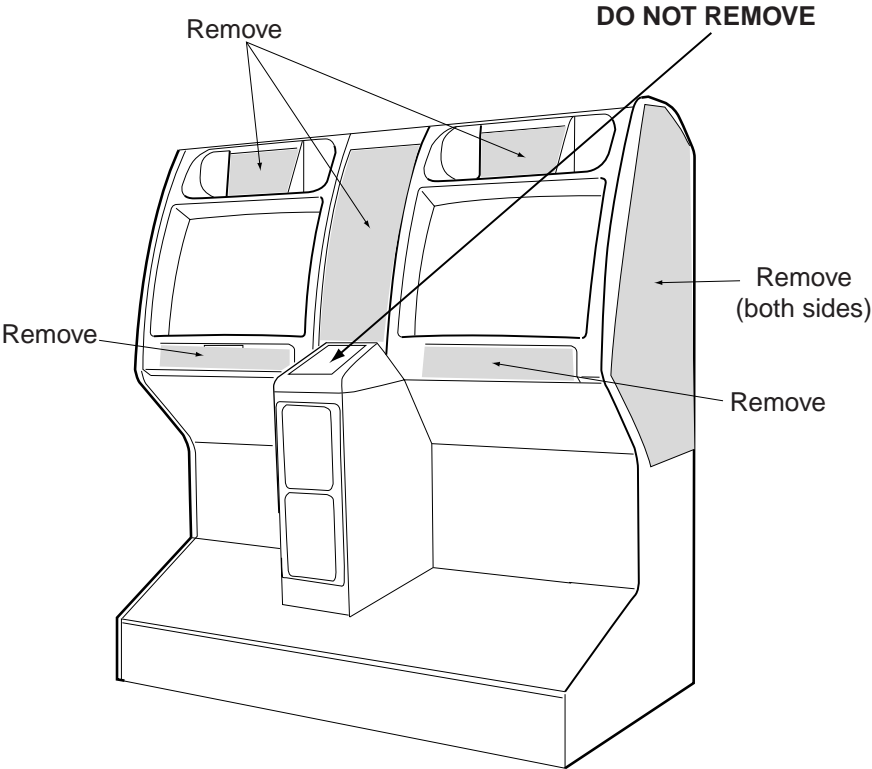

2. Fit the new decals as shown below.

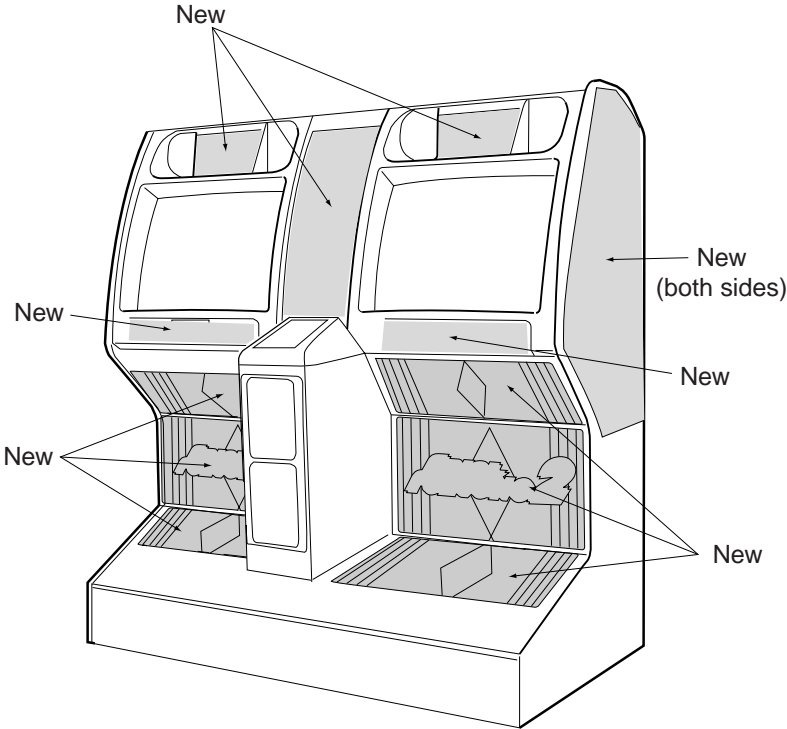

Fitting the New Front Vac-Form

1. Fit the new Vac-Form Bracket with 2 off torx security screw (M5x16 black), supplied.

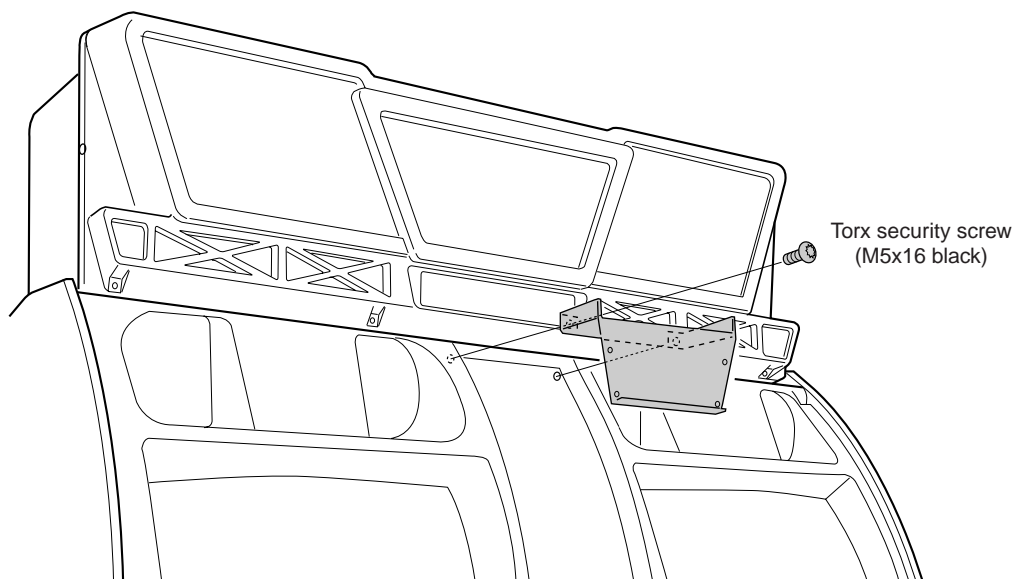

2. Fit the new Vac-Form with 4 off Torx security screw (M5x16 black), supplied.

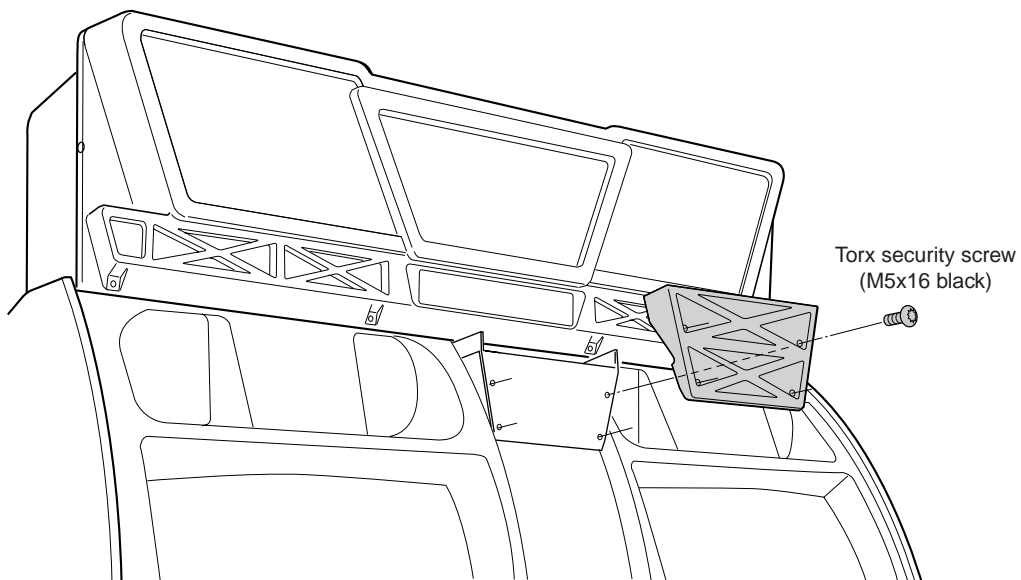

Replacing the Game PCB

1. Disconnect all the connectors on the Game PCB including the fan connectors.
Note: Some of the cables will be replaced with new cables (see illustration below)

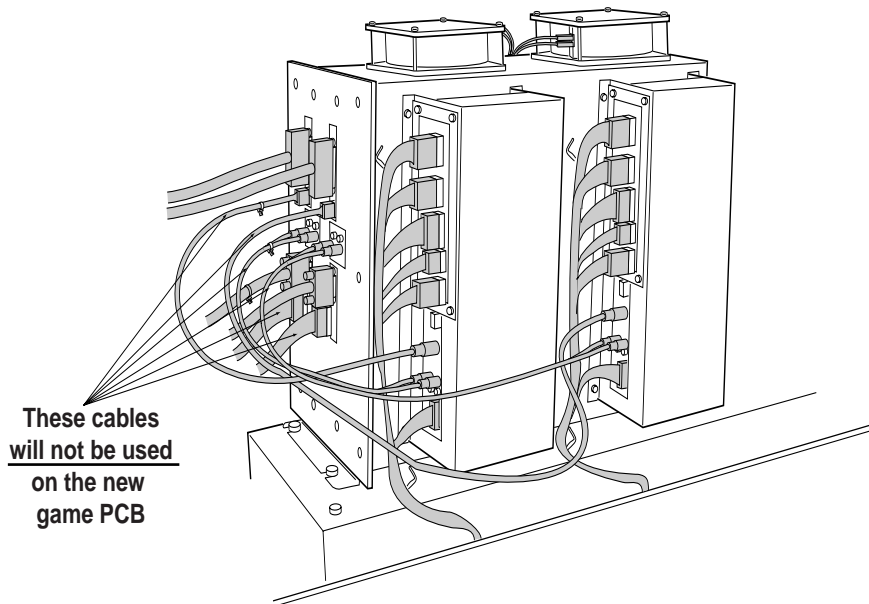

2. Remove the 2off pozi head screws (M6x25) from the right hand end of the Game PCB. slacken the 2off pozi head screws (M6x25) on the left hand end and remove the Game PCB.

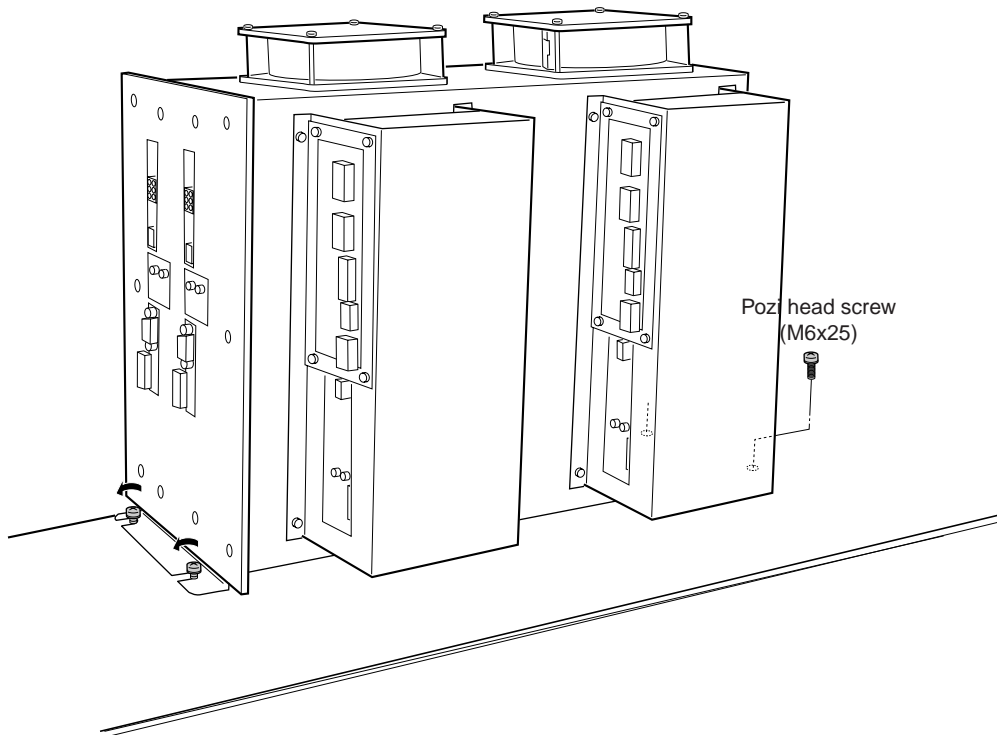

3. Place the old and new game PCBs next to each other.
4. Remove 8 off pozi head screws (M4x50) and remove the fans from the old Game PCB. (4 screws on each fan).

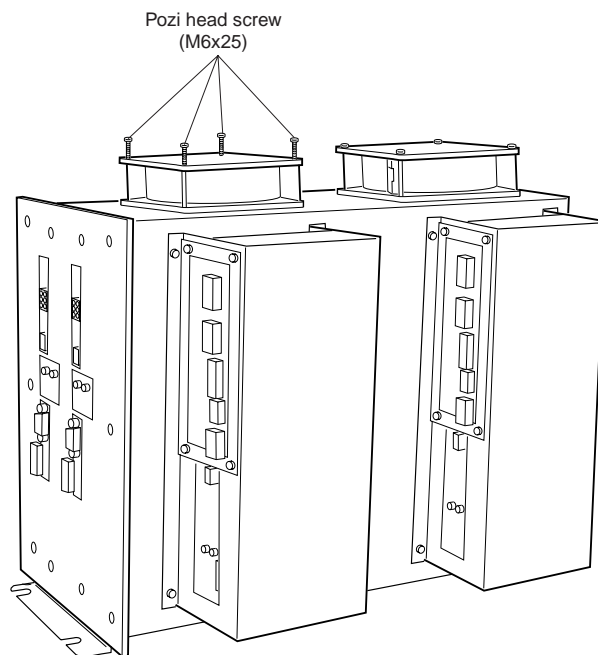

5. Fit the fans to the new Game PCB in **exactly the same way up** using 4 off pozi head screws (M4x50). (2 screws on each fan).

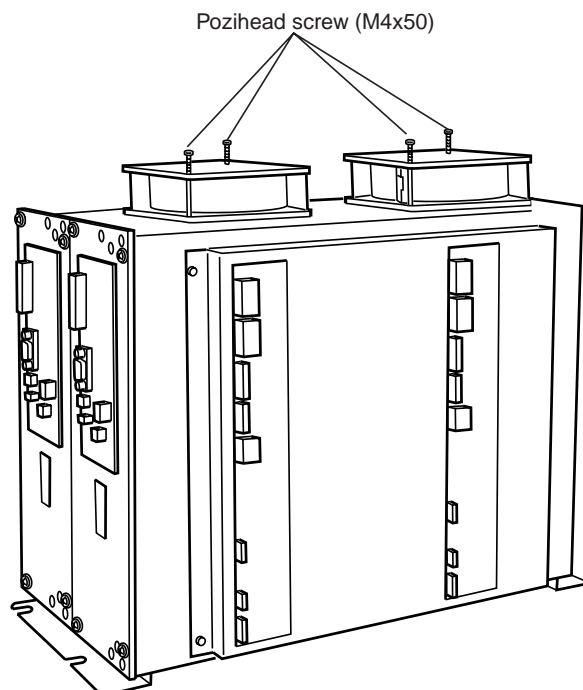

**THESE FANS MUST BE FITTED TO THE NEW GAME PCB
OR IRREPERABLE DAMAGE WILL BE CAUSED TO THE
NEW GAME PCB.**

6. Refit the new Game PCB and fully tighten the 4 off pozi head screws (Mx25).
7. Connect the new cables linking the I/O boards to the Front Cover Boards, and the new HSB cable linking the two front cover boards.

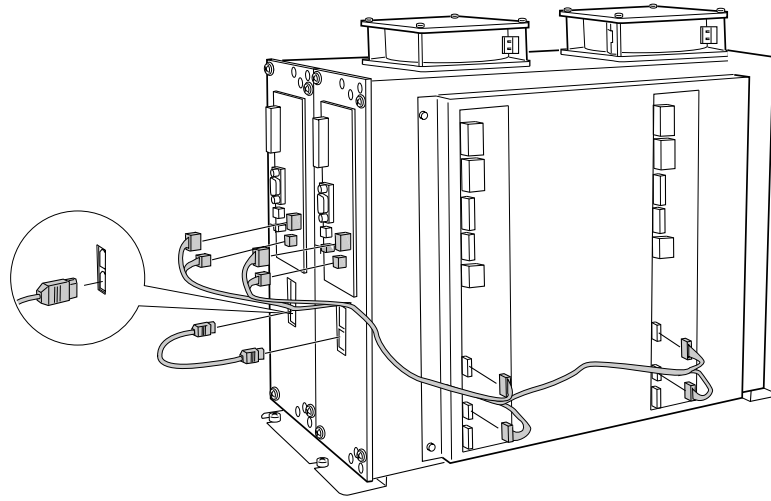

8. Locate and separate the two way connector with yellow and black wires. This is located to the right of the Switchmode Power Supply.
9. Fit the new break out cable to the two way connectors and connect the other ends to the front cover boards, as shown in the diagram below.

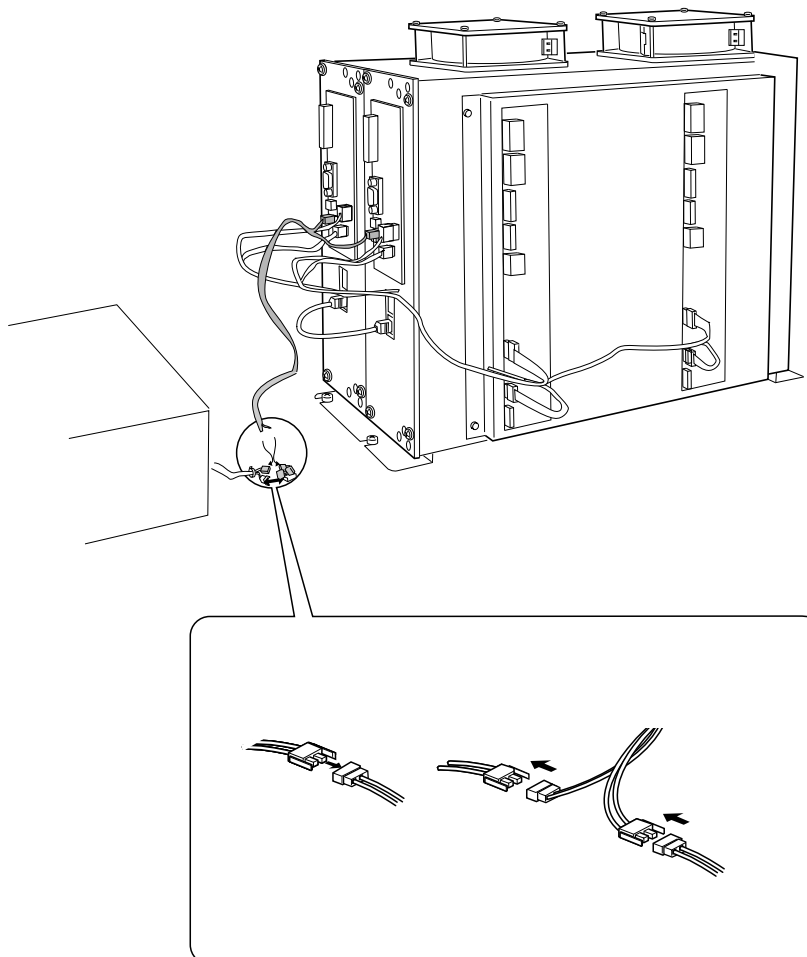

10. Refit the existing connectors to the I/O Boards and Front Cover Boards.

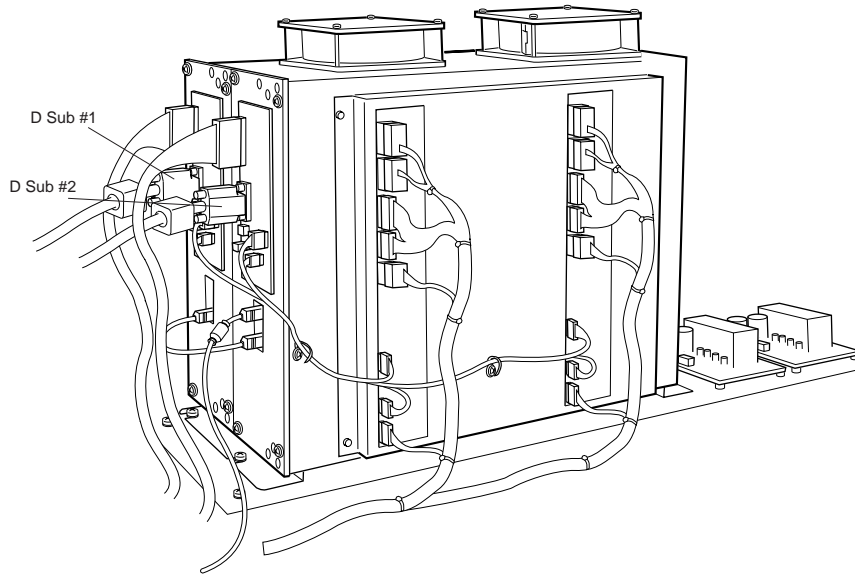

Note: When refitting the D Sub connectors to the Front Boards ensure that connector 2 is fitted to the board nearest the rear of the cabinet, and the connector retaining screws are fully tightened.

Replacing the Repeater (Link) PCB

1. Remove 1 off pozi head screw (M5x12) and remove the Link Cover Bracket.

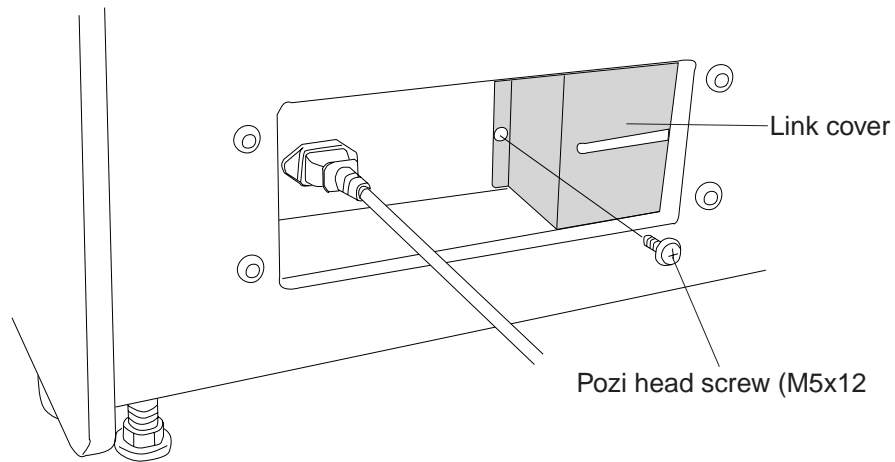

2. Remove 2 off Pozi head screws (M4x12) and remove the Link PCB complete with mounting bracket.
3. Disconnect the connectors.

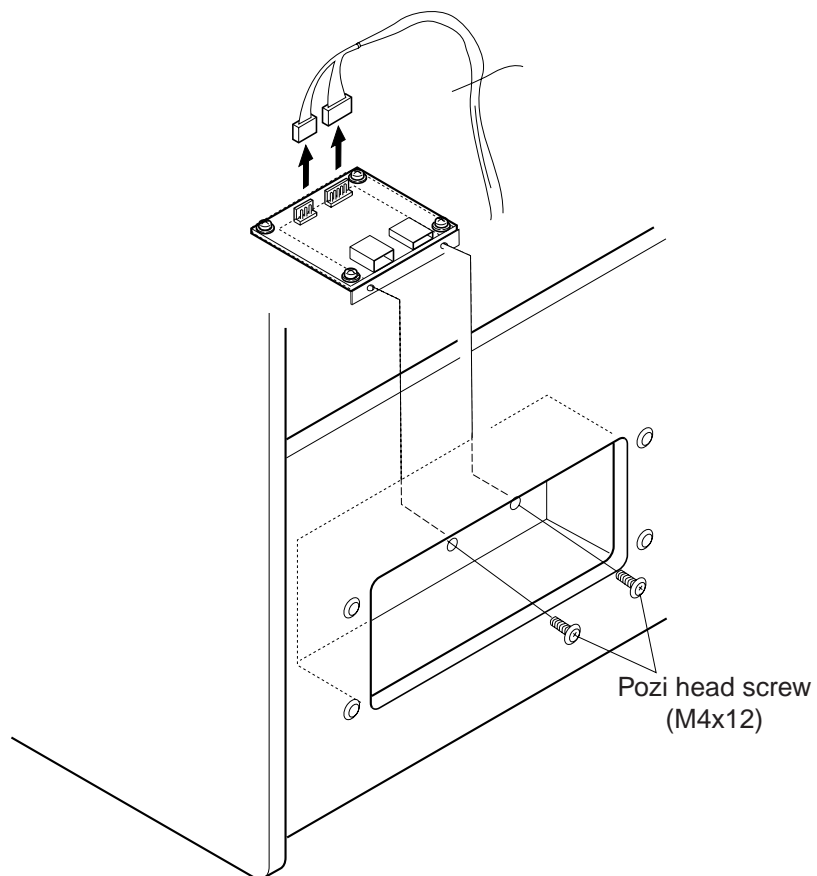

4. Refit the new Link PCB complete with mounting bracket using the 2 off pozi head screws (M4x12).

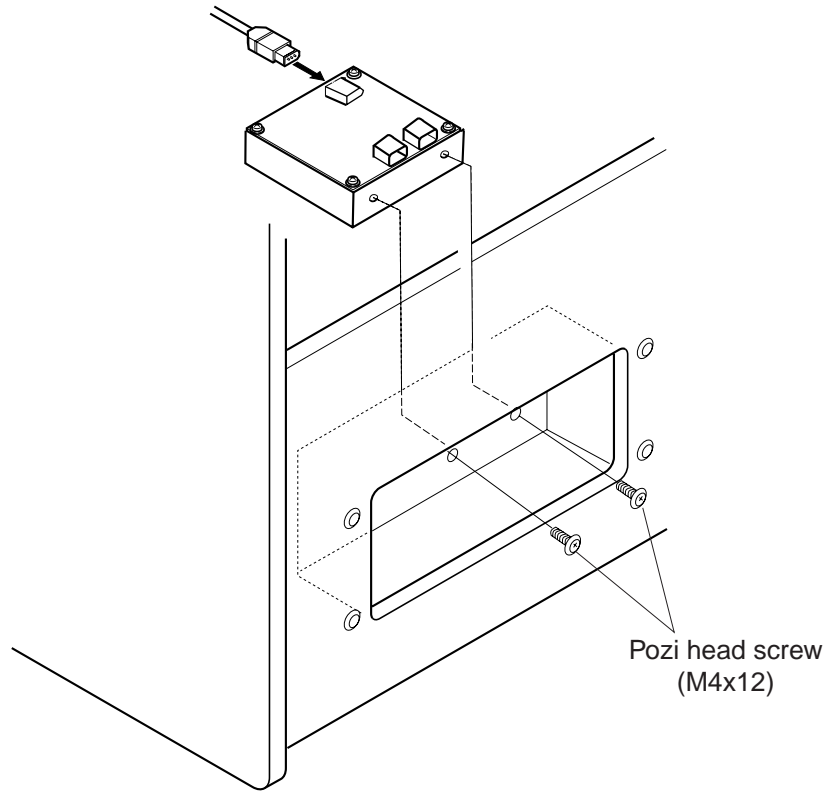

5. Fit the new Communication cable.

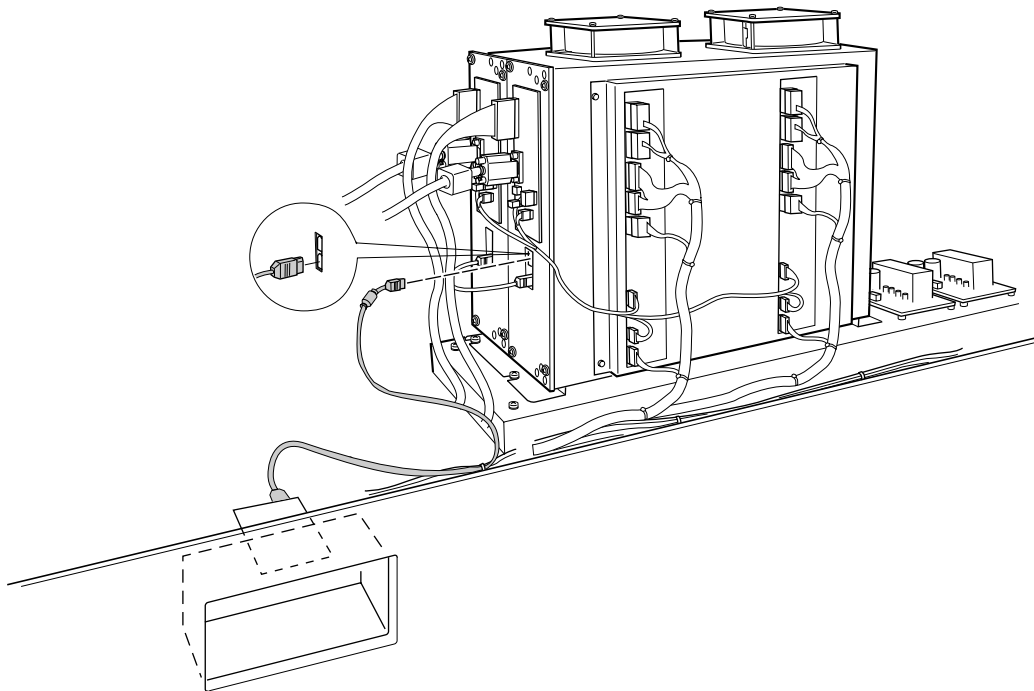

RE-ASSEMBLY AND TEST

1. Reassemble the Ride Assemblies to the Monitor Cabinet, taking care not to trap any wires.
2. Reconnect the Mains-In and switch ON.
3. Reinitialize both players. (see section 6-8 page 58 of the Operators Manual).
4. Reset all game settings to the required levels. (see section 6-7 'Test Mode' page 47 of the Operators Manual).

CONVERSION IS NOW COMPLETE.

NEW PART NUMBERS

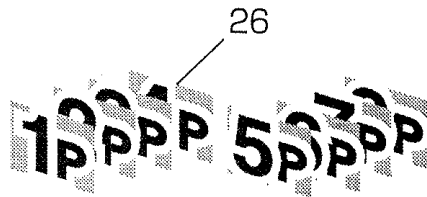
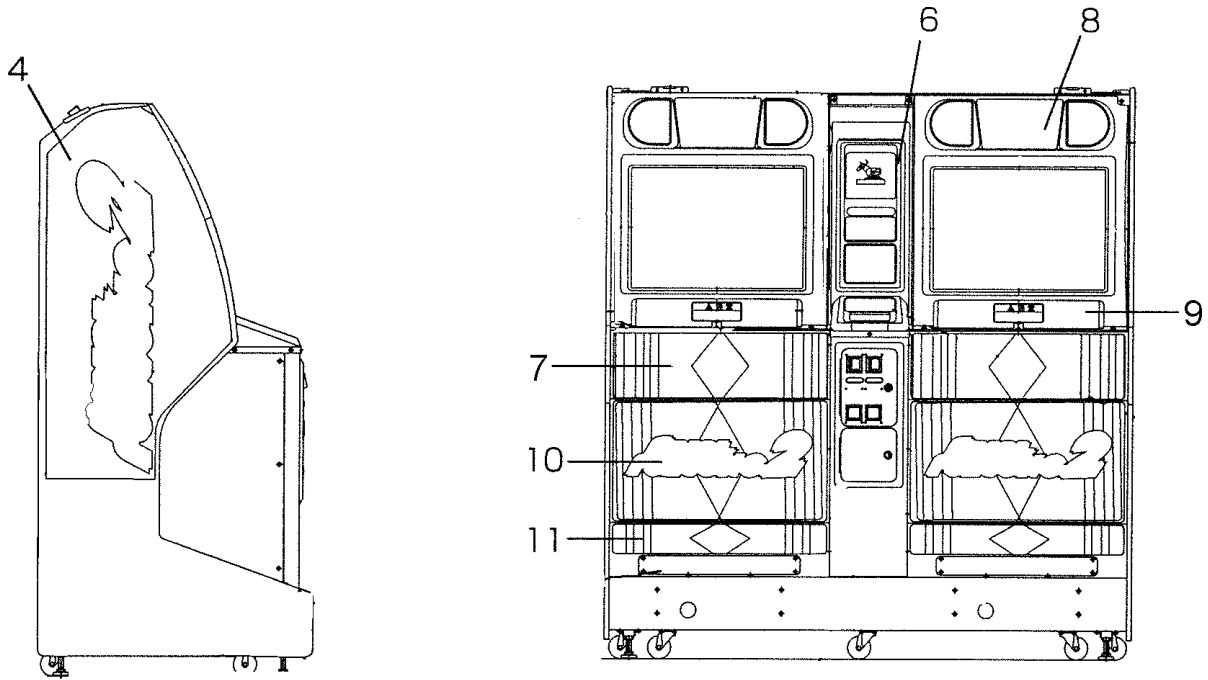

Item	Description	Part No
4	FF2 Cabinet Side Decal (LHS)	692-810
5	FF2 Cabinet Side Decal (RHS)	692-811
6	FF2 Instruction (A) Decal	692-896
7	FF2 Cabinet Front (A) Decal	692-815
8	FF2 Monitor Vac-Form Upper Decal	692-823
9	FF2 Monitor Vac-Form Lower Decal	692-898
10	FF2 Cabinet Front (B) Decal	692-816
11	FF2 Cabinet Front (C) Decal	692-817
26	FF2 Number Decals (set)	692-813

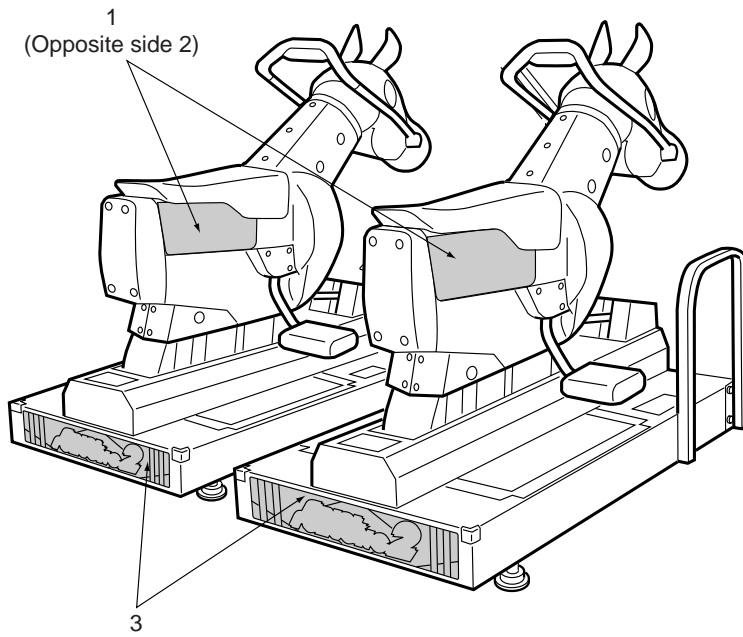

Item	Description	Part No
1	Horse Rear Decal (RHS)	692-843
2	Horse Rear Decal (LHS)	692-842
3	FF2 Base Decal	692-850

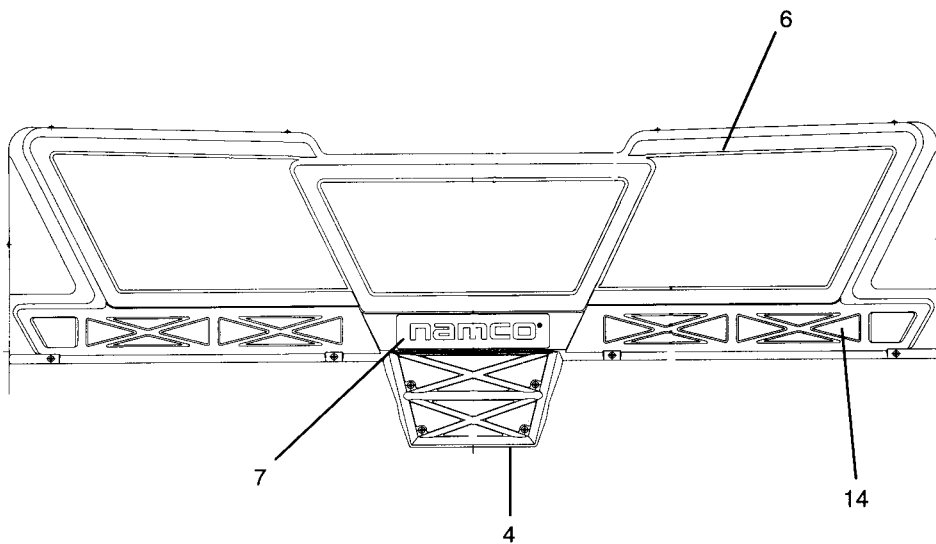

Item	Description	Part No
4	Truss Cover	692-861
6	FF2 Signboard Cover	692-860
7	Centre Logo Decal	692-863
14	Light Plate	692-862