

namco[®]



This document has been downloaded from:



FLIPPERSPILL.COM

Operators Manual

IT IS THE RESPONSIBILITY OF THE OPERATOR TO MAINTAIN CUSTOMER SAFETY AT ALL TIMES, AND IT IS IMPERATIVE THAT THE DETAILS SET OUT IN THIS MANUAL ARE FOLLOWED PRECISELY,

© 1996 **NAMCO LIMITED**. all rights reserved.

No part of this publication may be reproduced by any mechanical, photographic or electronic process, or in the form of phonographic recording, nor may it be stored in a retrieval system, transmitted or otherwise copied for public or private use, without permission from **NAMCO EUROPE LIMITED**

While the information contained in this manual is given in good faith and was accurate at the time of publication, **NAMCO EUROPE LIMITED** reserve the right to make changes and alterations without notice.

This machine has been manufactured in accordance with European Community directives (1st. January 1996), and as such bears the **CE** marking. Any changes or modifications to this machine must be in accordance with European Community directives (1st. January 1996).

If you make any unauthorised changes to this product, you may contravene European Community directives (1st. January 1996).

Under some conditions of extreme external interference, e.g. radio transmissions, electrostatic discharge or mains borne transients, some degradation of performance may occur. However the machine will recover normal performance once the source of interference has ceased or been removed.

Following abnormally high voltage surges on the mains supply the video monitor may need to be manually reset by turning the machine OFF and back ON.

Published by:
NAMCO EUROPE LIMITED
Namco House,
8 Acton Park Estate,
The Vale,
London W3. 7QE

Phone:- 0208-324-6000
Fax:- 0208-324-6010

SAFETY WARNING

In order to use this machine safely, be sure to read this Installation and commissioning manual carefully before installation, adjustment or use of this machine.

Whenever the owner of this machine entrusts disassembly, installation, adjustment or routine maintenance to another person, the owner should ensure that that person read the appropriate precautions and relevant sections of this manual before starting work.

In order that no accidents occur when the machine is in operation, strictly follow the notes on safety described below. Also, carefully read section (X), "Precautions".

Warnings for Operation ((€ Requirements)

NOTE: Only operate this machine after checking that it has been installed correctly and in accordance with the Installation and Commissioning Manual.

NOTE: Parts of this machine move during game play, so there are places where the distance between the stationary section and moveable section changes. There are warning notices to keep hands and feet clear of moving parts, however if the operator feels that a person is in any danger, he should warn that person accordingly.

NOTE: The warning notices must always be kept in good condition and replaced if worn, so that the customer can read them clearly.

NOTE: **If there is an error or problem with the machine, operation must be stopped immediately and the problem rectified before any further use.**

NOTE: Installation, Service, Adjustments and Routine Maintenance should be carried out by qualified personnel only.

Warnings for Disassembly, Installation, Routine Maintenance and Troubleshooting.

DANGER: Namco Ltd. bears absolutely no responsibility for accidents, injury or damage resulting from unauthorized changes to this machine.

DANGER: Ensure that the machine has been turned **OFF** before making adjustments or carrying out maintenance. Also ensure only qualified personnel turn the power **ON** to this machine.

DANGER: The power supply and inside the monitor will remain hot and have areas of high voltage even though the machine has been turned OFF, and there is the possibility of burns or electric shock. Be careful not to touch these areas.

DANGER: In order to prevent injury due to mis-operation, be sure that the voltage of the main power supply is within the prescribed limits. Also to prevent possible electric shock due to failure, this machine **MUST** be fitted with a securely connected earthed plug.

NOTE: Do not turn the power switch **ON** until the machine has been installed correctly.

Contents

Operators Manual	1
SAFETY WARNING	3
1. SPECIFICATIONS	5
2. HOW TO PLAY	6
3. MAJOR COMPONENTS	7
4. INSTALLATION	8
4-1 Fitting the Header Assembly	9
4-2 Connecting the Cycle Assy to the Monitor Cabinet	10
4-3 Removing the Shipping Bracket	11
5. ADJUSTMENTS	12
5-1 Turning on the Power	12
5-2 Adjustment Switches	12
5-3 Test Mode	13
5-3-1 Coin Options	14
5-3-2 Game Options	15
5-3-3 I/O Test	16
5-3-3-1 Switch Test	17
5-3-3-2 Pedal Test	18
5-3-3-3 Fan Motor Test	19
5-3-3-4 Lamp Test	20
5-3-4 Monitor Test	20
5-3-5 Sound Test	21
5-3-6 ADS Data	21
5-3-7 OTHERS	21
6. INITIALIZATION	22
Adjustments When Replacing Parts (Initialization)	22
7. MAINTENANCE	23
7-1 Pedal Pressure Adjustment	24
7-2 Inspecting or Adjusting the Drive Belt	25
6-2-1 Adjusting the Drive Belt	25
7-3 Removing the Flywheel or Drive Belt	26
7-4 Inspecting and Replacing the Pedal Sensor Sticker	29
7-5 Replacing the Fluorescent Tube	30
7-6 Replacing the Fan	31
7-7 Replacing the Start Switch	33
7-8 Removing the Handle Covers	33
7-9 Replacing the Handle Assembly	34
7-10 Replacing the Handle Pots	35
7-10-1 Replacing the Up/Down Pot	35
7-10-2 Replacing the Left/Right Pot	36
7-11 Replacing the Pedals	37
7-12 Replacing the Vibration Proof Rubbers	39
7-13 Replacing the Rubber Stoppers	42
8. PARTS LIST	43
9. SCHEMATICS	56

1. SPECIFICATIONS

POWER SUPPLY:- 230volts AC

MONITOR:- Thomson 52" Projector Monitor (RP52)

COIN ACCEPTOR:- Mars CashFlow - 1 Channel

DIMENSIONS:-

Assembled	1250(w) x 2430(d) x 2320(h)
Monitor Cabinet	1250(w) x 645(d) x 1940(h)
Cycle Assembly	980 (w) x 1785(d) x 1380(h)
Header Assembly	1145(w) x 350(d) x 380(h)

WEIGHT:-

Assembled	411kg
Monitor Cabinet	200kg
Cycle Assembly	193kg
Header Assembly	18kg

ACCESSORIES:-

Keys:	(Cash Door)	2
	(Coin Door)	2
	(Back Door)	2
	IEC Mains Lead	1
	Operators Manual.....	1
	Installation Manual	1
	Monitor Manual	1
	Monitor Remote Control W/Batteries	1
	CashFlow Documents	1
	Joint Bracket - LHS (Cabinet/Bike Assy).....	1
	Joint Bracket - RHS (Cabinet/Bike Assy)	1
	Potentiometer	1
	M8x50 Hex Head Set Screw S/Steel	2
	M8x25 Hex Head Set Screw S/Steel	4
	M8 Spring Washer S/Steel	6
	M8 Flat Washer S/Steel	6
	M5 Security Wrench.....	1
	M4 Security Wrench.....	1

2. HOW TO PLAY

This is a new flight game in which the player gains points by riding a human-powered propcycle and flying freely in the sky.

The player flies the propcycle and gains points by hitting and popping floating red balloons.

(1) Operation

The game is operated by using the handlebars and pedals.

Handle:

- Handle Backward = Climb : The cycle gains altitude but loses speed.
- Handle Forward = Drop : The cycle loses altitude but gains speed.
- Handle Left = Turn Left.
- Handle Right = Turn Right.

Pedals:

- The cycle accelerates according to the pedalling speed.
- The cycle decelerates by pedalling backwards.

If the cycle is flown without moving the pedals, the speed drops gradually. If the speed drops below a certain level, the cycle begins to drop rapidly. Speed is lost if the player does not pedal fast enough to gain the desired altitude.

(2) Modes

There are two modes of play which can be selected at the start of a game.

1) Novice (Point / Speed mode)

The level of difficulty is rather easy, so any can enjoy the game.

One of three stages is selected at the start of the game, and the objective is to burst as many balloons and score as many points as possible in the allotted time.

The player attempts to burst all the balloons for a perfect score in the allotted time to record their name as the best time.

There is only one stage play, and continued play is not possible.

2) Advanced Mode (Story mode)

The level of difficulty is higher than Novice.

The player aims to reach the final destination, "Solitar", by clearing all three stages in any order they choose. Each time a stage is cleared by reaching the required points total in the given time, play continues into the next stage. If a player fails to clear a stage within the given time the 'continue' screen is displayed. Each time the game is continued the required points for clearing a stage is reduced.

After all three stages have been cleared, it is possible to challenge for "Solitar".

If the "Solitar" is cleared, it is possible to see the final game ending. It is not possible to continue in the "Solitar".

3. MAJOR COMPONENTS

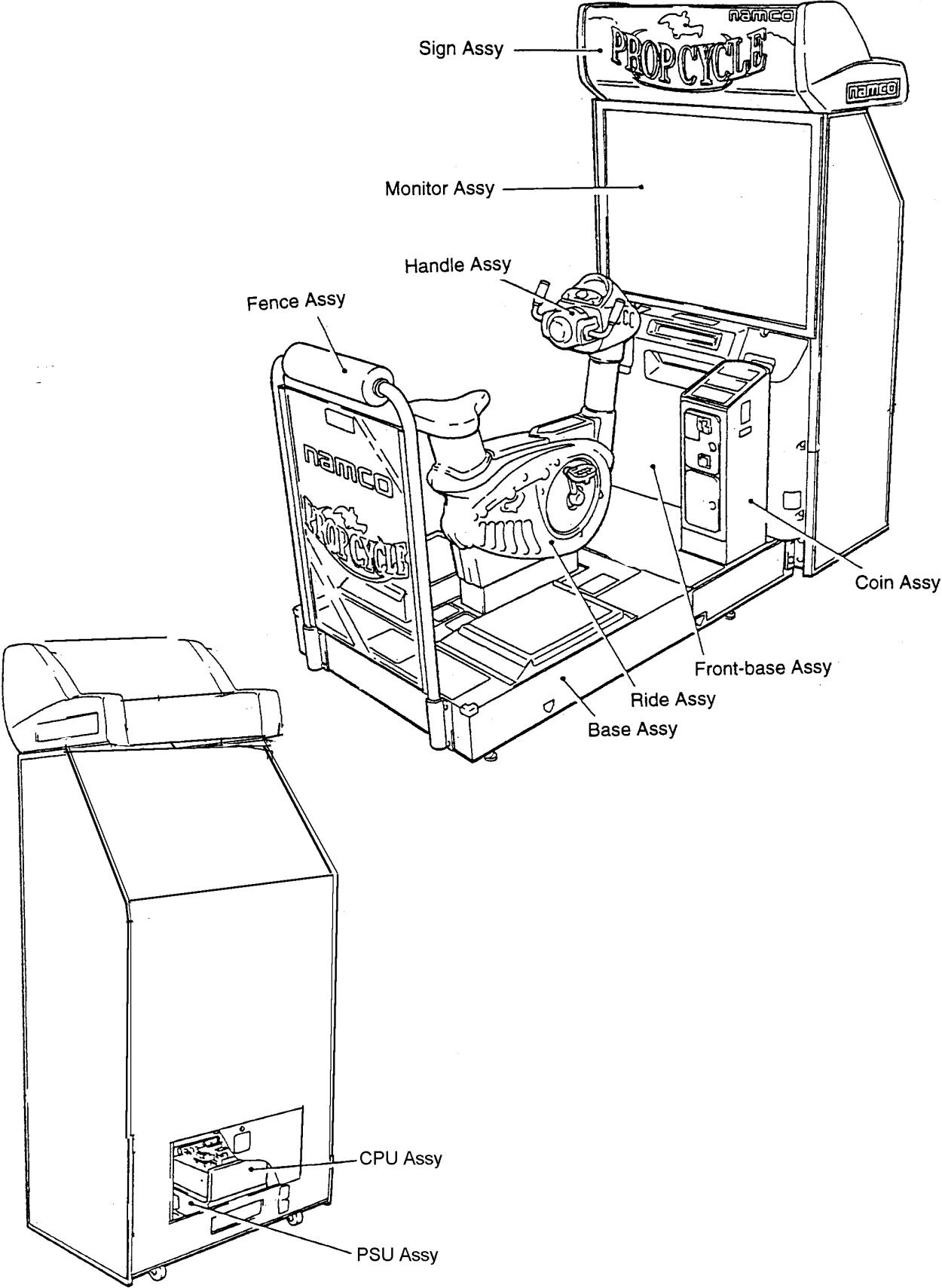

4. INSTALLATION

Notes on Installation

DANGER NEVER turn the power to the machine ON until installation has been completed.

DANGER In order to avoid injury or damage to the machine due to mis-operation, ensure that the voltage of the mains supply is 230volts AC.
Also, in order to prevent possible electric shocks, be sure that the machine is connected to the mains supply with a securely connected earthed plug.

WARNING If the location site of this machine has a polished floor it is recommended that rubber pads are fitted under the level adjusters to prevent the machine sliding on the floor.

NOTE So that customers are not injured by the movement of the Cycle, ensure that there is at least 500mm separation between other machines or walls.

NOTE In order to gain access to the Power Supply and CPU assemblies, make sure that the rear of the main cabinet is separated from a wall or other machine by at least 500mm.

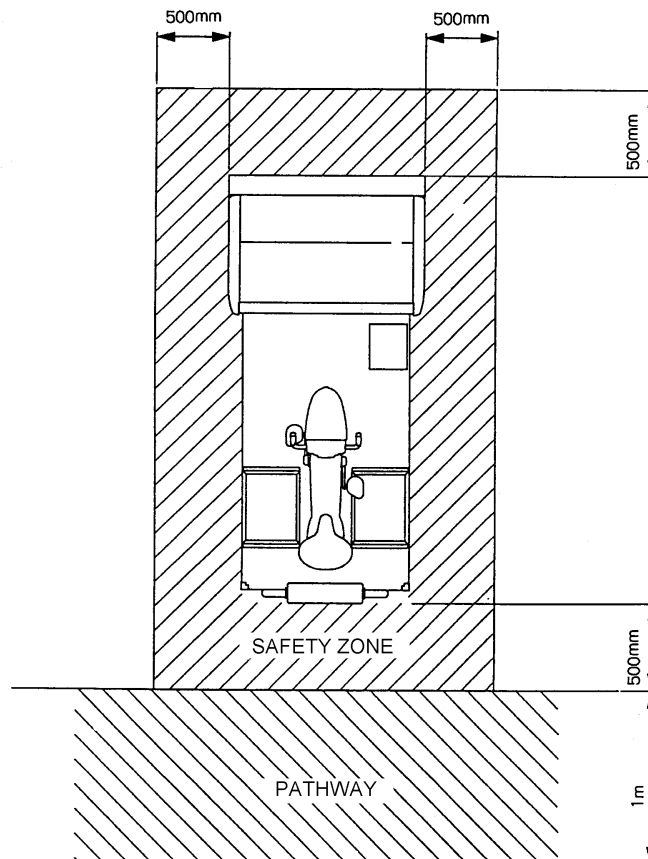

WARNING

This machine is designed for indoor use only.

The game must **not be installed outdoors** or under the following conditions:-

- a. In areas directly exposed to sunlight, high humidity, direct water contact, dust, high heat or extreme cold.
- b. In locations that would present an obstacle in the case of an emergency, i.e. near fire equipment or emergency exits.
- c. On an unstable or uneven surface, or subject to floor vibration.

4-1 Fitting the Header Assembly

The Header Assembly has a forward centre of gravity, so it is important that at least two people are used to fit or remove the Header Assembly.

The fitting position of the Header Assembly is very high, and it is important that a means of reaching the height safely, without stretching, is available. (e.g. steps, step stools etc.)

1. Place the Header Assembly on to the monitor cabinet, connect the connectors and pass the connectors in to the cabinet, locate the blocks on the base of the Header Assembly into the cutouts on top of the Monitor Cabinet.
2. Fit the 2 off M8x50 Hex Head Screws, Spring and Flat Washers to retain the Header Assembly to the Monitor Cabinet.

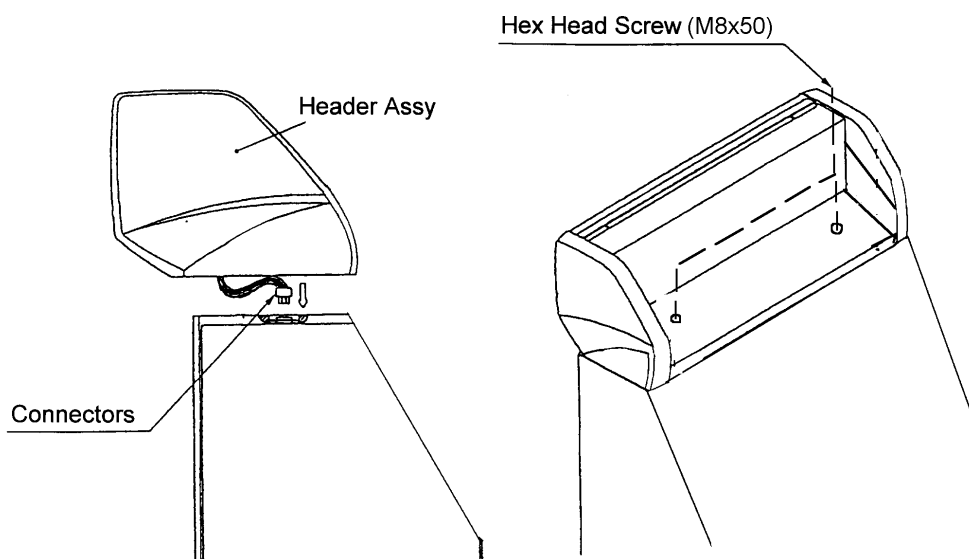

4-2 Connecting the Cycle Assy to the Monitor Cabinet

- 1, Connect the connectors between the Cycle Assembly And the Monitor Cabinet.
2. Remove 2off Hex Head Set Screws (M8x25), Spring and Flat Washers on each Joint Bracket, turn the Bracket over and refit, finger tight, using the same screws and washers.
3. Push the Cycle Assembly fully up to the Monitor Cabinet, taking care not to trap any wires.
- 4 Fit the Joint Brackets, finger tight, to the Monitor Cabinet using 2off Hex Head Set Screws (M8x25), Spring and Flat Washers for each bracket. When all screws have been located, tighten all the screws fully.

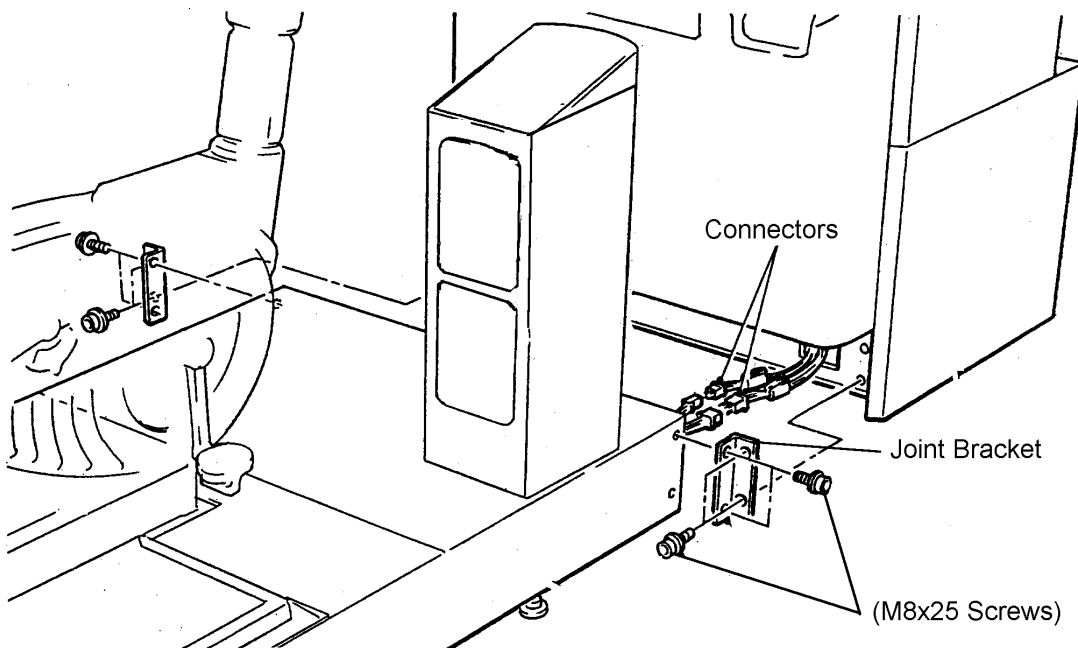

NOTE:-

When the machine is fully assembled and in its final position, lower the 8 level adjusters, (4ea on the Monitor cabinet and Cycle Assy), with a spanner so that the machine is level and all castors are raised from the floor by approx. 5mm. Tighten the lock nuts with a spanner to ensure that the level adjusters do not move.

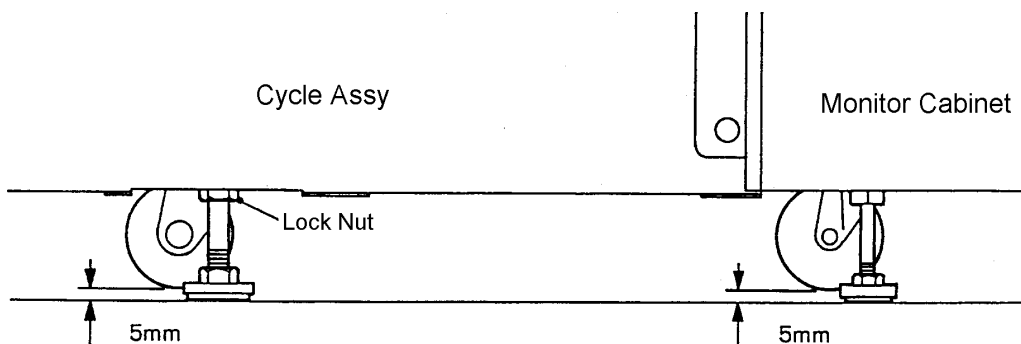

4-3 Removing the Shipping Bracket

1. Remove the two Hex Head Set Screws (M8x16) retaining the shipping bracket to the Cycle Base.
2. Remove the two Hex Head Set Screws (M12x20) retaining the shipping bracket to the Cycle Assembly.
3. Remove the shipping bracket. (Ensure that the bracket and the M8 screws and washers are retained safely for refitting if the machine is moved or transported in the future.)
4. Refit the two Hex Head Screws (M12x20) with washers to the Cycle Assembly and tighten fully.

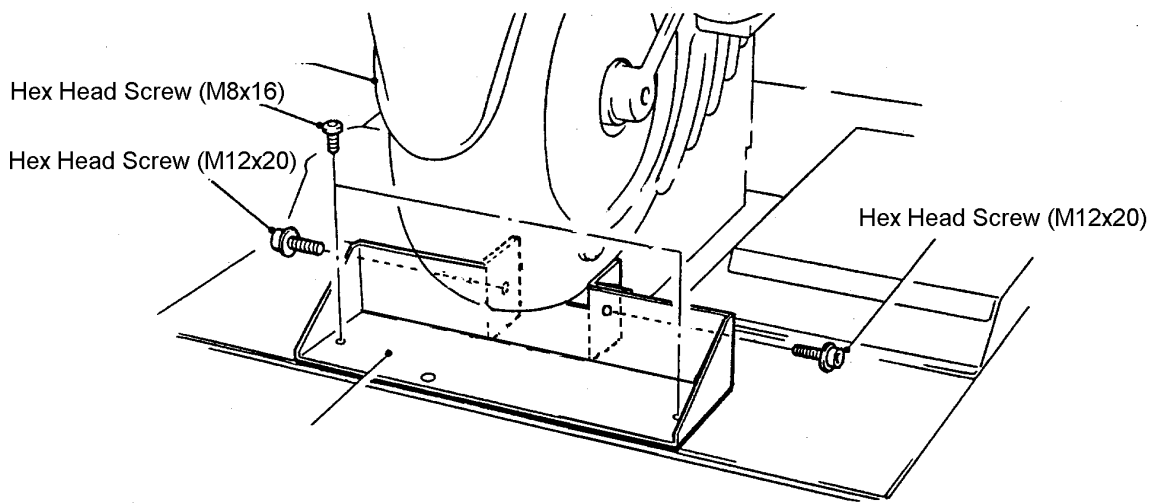

5. ADJUSTMENTS

5-1 Turning on the Power

After the machine has been installed, turn ON the power. The Power switch is located on the rear of the Main cabinet. (See section 3 “Major Components” (page 3).)

5-2 Adjustment Switches

The adjustment switches are located inside the coin door.

1. Service Switch
Press this switch to obtain game credits without incrementing the play meters.
2. Test Switch
Slide this switch “ON” to enter test mode.
Test mode allows game testing and the changing of game settings. (Refer to [section 5-3 “Test Mode” \(page 13\).](#))

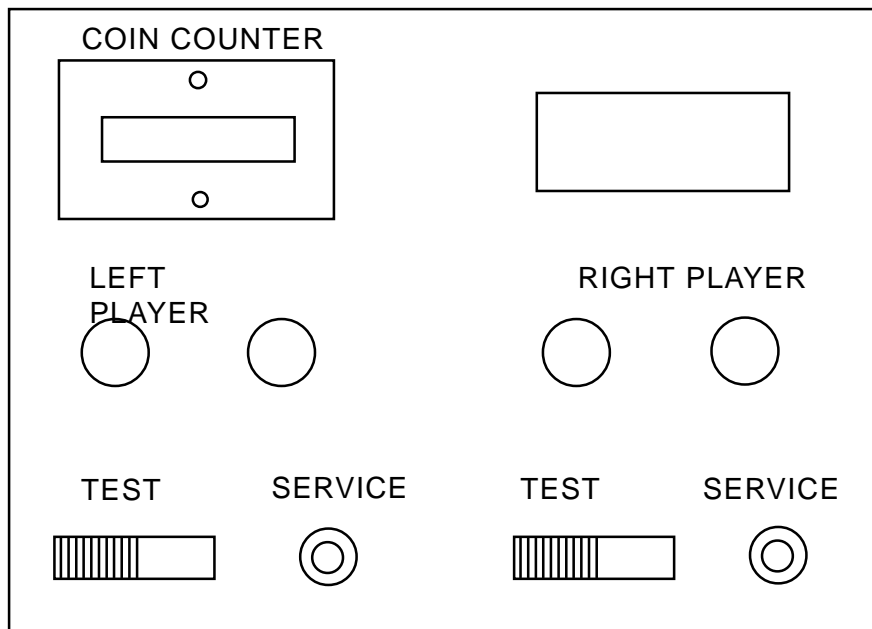

5-3 Test Mode

1. Open the coin door and slide the test switch "ON". The "Menu Screen" will be displayed on the monitor.
2. Select the test required by moving the handle bars up or down. The colour of the selected test will change.
3. Enter the selected test by pressing the start button. Select "EXIT" to return to the "Menu Screen"
4. After testing is completed, ensure that the test switch is returned to the "OFF" position to return to game mode.

The Test Switch must always be in the "OFF" position for normal game mode.

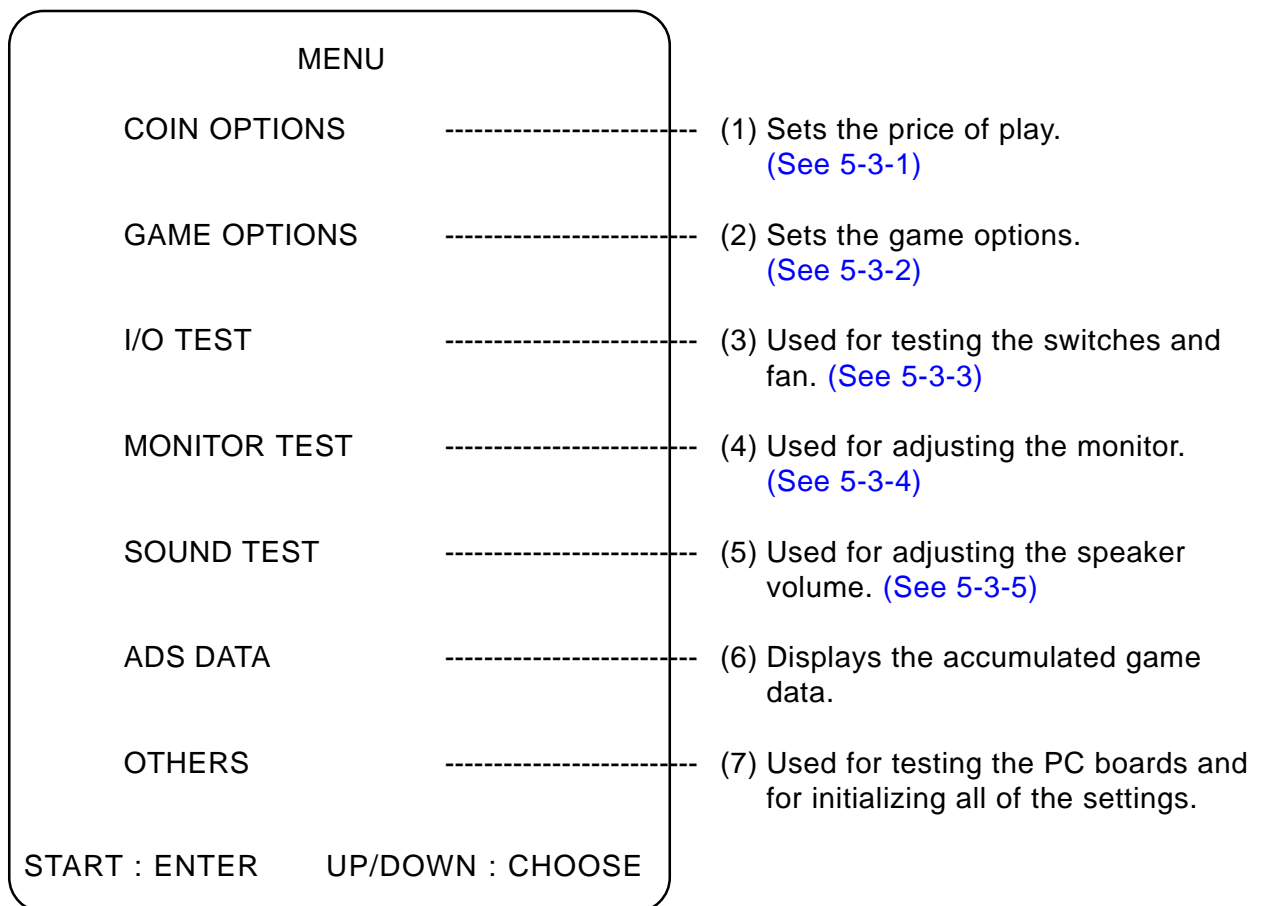

5-3-1 Coin Options

- a. Select item (1) "COIN OPTIONS" on the menu screen, to set the game cost and related settings.
- b. Move the handle bars up or down to select the required item then press the start button.
- c. Move the handle bars left or right to change the settings then press the start button to store the new values.
- d. Select "EXIT" and press the start button to return to the menu screen.

Note:- The price of play on this machine is set within the Cashflow Coin Mech. Ensure that the Coin Options on the screen are set as shown in the following table.

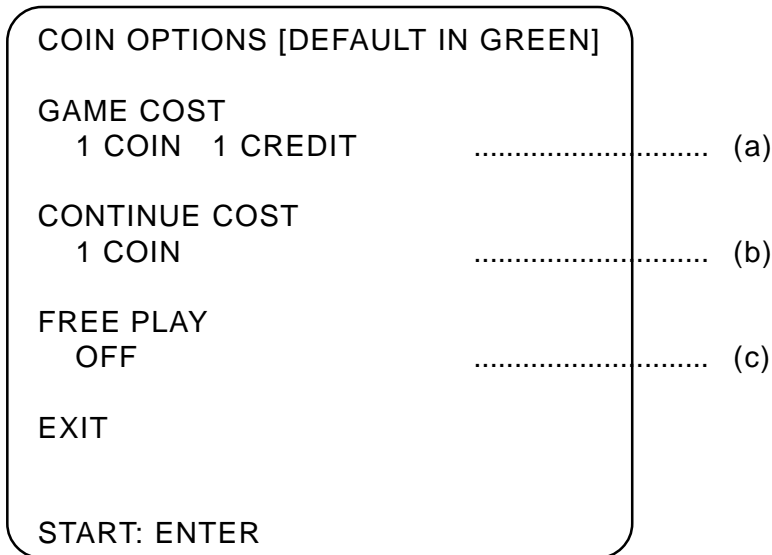

ITEM	CONTENTS	FACTORY SET
(a) Game Cost	Coins required for one credit - - - - - settable 1 - 9	1
(b) Continue Cost	Coins required to continue play - - - - - settable 1 - 9	1
(c) Free Play	No coins required for game - - - - - On / Off	OFF

5-3-2 Game Options

- a. Select item (2) "GAME OPTIONS" on the menu screen to set the game options.
- b. Move the handle bars up or down to select the required item then press the start button.
- c. Move the handle bars left or right to change the settings then press the start button to store the new values.
- d. Select "EXIT" and press the start button to return to the menu screen.

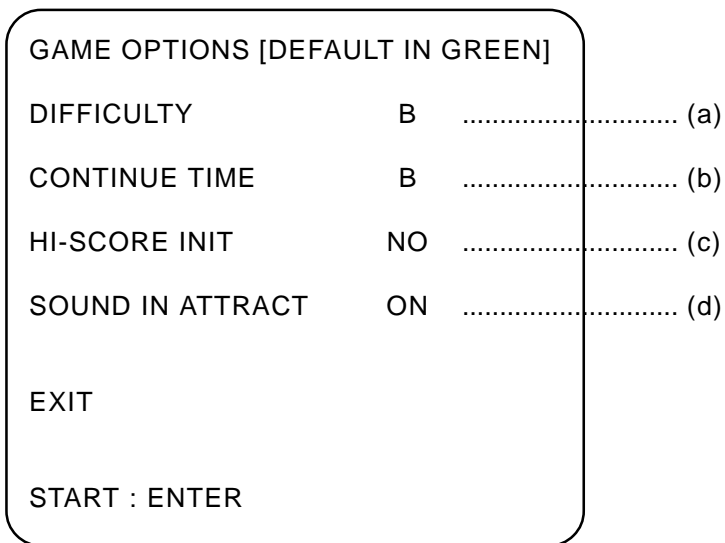

ITEM	CONTENTS	FACTORY SET
(a) Difficulty	A (easy) to C (hard)	B
(b) Continue Time	Time allowed to continue new game. A (long) to C (short)	B
(c) Hi-Score Init	Yes / No (If Yes, Hi-Score will be reset when exiting test)	NO
(d) Attract Sound	Sound during standby attract mode Yes / No	YES

5-3-3 I/O Test

- a. Select item (3) "I/O TEST" on the menu screen.
- b. Move the handle bars up or down to select the required item then press the start button.
- c. Move the handle bars left or right to change the settings then press the start button to store the new values.
- d. Select "EXIT" and press the start button to return to the menu screen

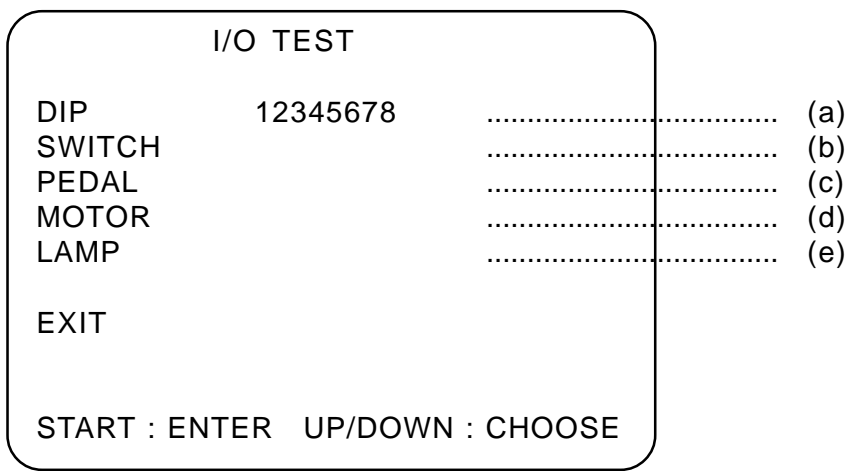

- (a) Displays the state of the PCB Dip switches, when a switch is ON the number is shown in red.
- (b) Tests the switches and handle bars. ([See 5-3-3-1.](#))
- (c) Tests the pedals ([See 5-3-3-2.](#))
- (d) Tests the fan motor. ([See 5-3-3-3.](#))
- (e) Tests the start button lamp. ([See 5-3-3-4.](#))

5-3-3-1 Switch Test

- a. Select "SWITCH" on the menu screen and press the start button. The following screen is displayed.

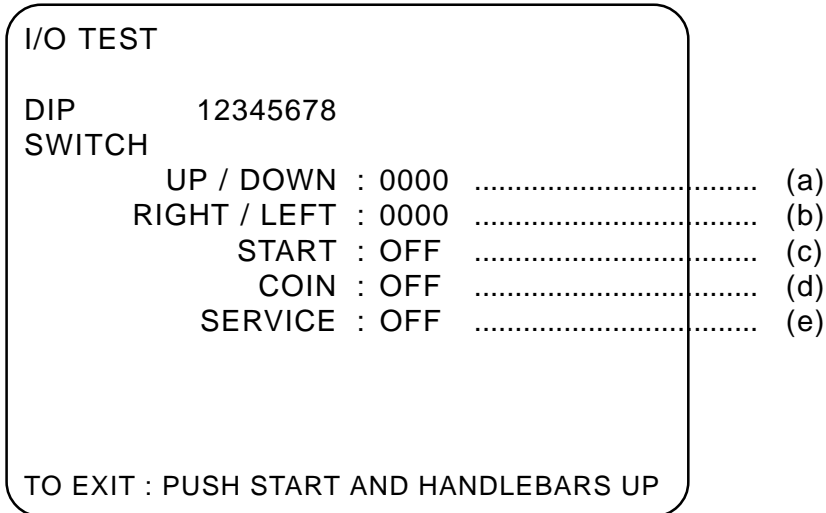

- (a) Handle Bar up/down: When the handle bar is pulled back the value of 0000 will increase and 'OK' will appear when the handle bar is fully back.
- (b) Handle Bar left/right: When the handle bar is pushed forward the value of 0000 will decrease and 'OK' will appear when the handle bar is fully forward.
- Note: It is normal for 0000 to be changing slightly when the handle bar is in the neutral position.*
- (c) Start button 'OFF' will change to 'ON' each time the start button is pressed.
- (d) Coin switch 'OFF' will change to 'ON' when the coins to the correct game value have been inserted through the Cashflow acceptor.
- (e) Service 'OFF' will change to 'ON' each time the service button is pressed.

NOTE: If 'OK' does not appear when the handle bars are at there extreme travel, re-initialize the game as described in section 4

5-3-3-2 Pedal Test

- a. Select "PEDAL" on the menu screen and press the start button. The following screen is displayed.

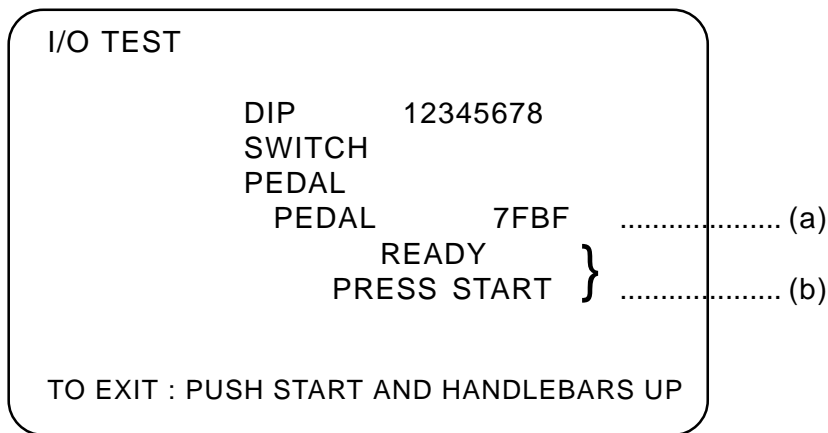

- (a) Pedal rotation When the pedals are rotated in the forward direction the value increases, and when they are rotated in the backward direction the value decreases.
- (b) Rotation sensor check This mode checks whether the sensor is reading the pedal rotation correctly. (see below)

- b. When the start button is pressed, the following screen is displayed.

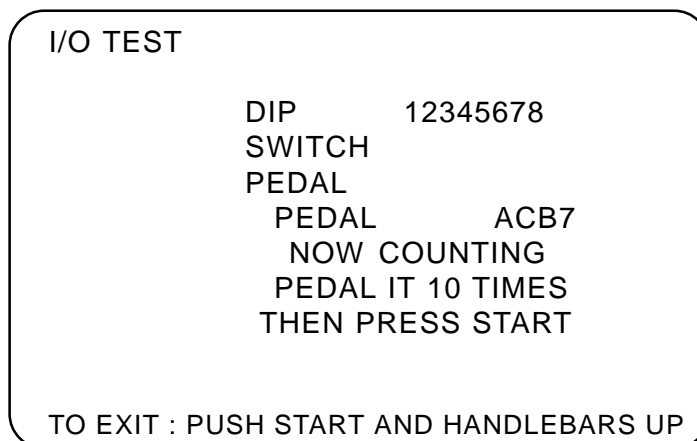

- c. When the above screen is displayed, pedal ten full turns in the forward direction. Stop as soon as the pedal has been turned exactly ten times.
- d. Press the start button again.

- e. When the start button has been pressed, the following screen is displayed.

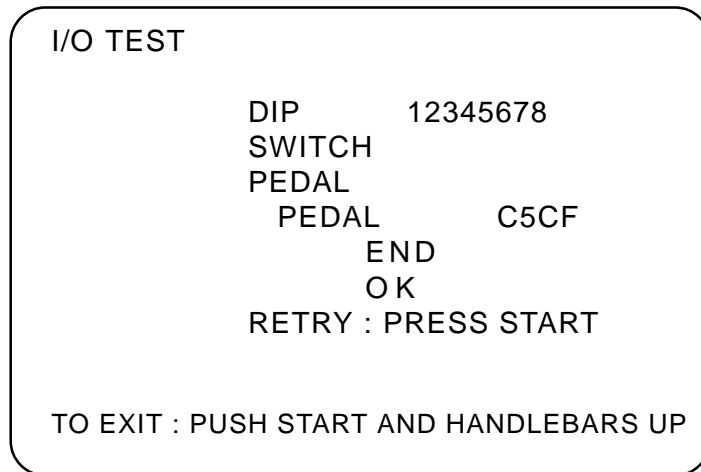

- f. If "OK" is displayed the pedals are correct.
If "NG" is displayed there has been a problem in reading the pedal rotation. Press start and repeat steps c) and d) again.
If "NG" is still displayed after repeating the test, there is the possibility that the sensor board or sensor sticker is faulty.
- g. Press the start button while pulling back on the handle bars, to return to the "I/O Test" menu.

5-3-3-3 Fan Motor Test

- a. Select "MOTOR" on the menu screen and press the start button. The following screen is displayed.

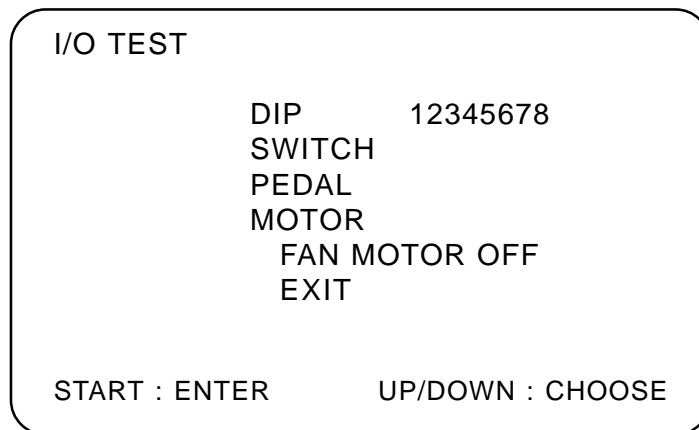

- b. When the start button is pressed once, 'OFF' changes to 'ON' and the fan motor starts and blows air from the front of the cabinet. When the start button is pressed again, 'ON' changes to 'OFF' and the fan motor stops.
- c. Select "EXIT" and press the start button to return to the "I/O Test" screen.

5-3-3-4 Lamp Test

- a. Select "LAMP" on the menu screen and press the start button. The following screen is displayed.

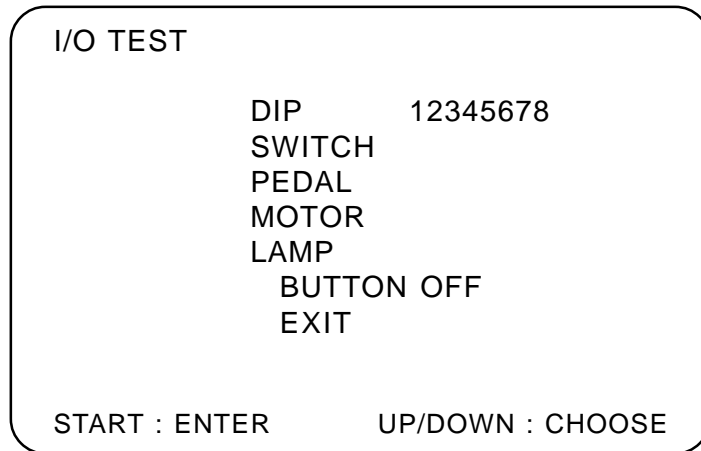

- b. When the start button is pressed once, 'OFF' changes to 'ON' and the start button lamp turns ON. When the start button is pressed again, 'ON' changes to 'OFF' and the start button lamp turns OFF.
- c. Select "EXIT" and press the start button to return to the "I/O Test" screen.

5-3-4 Monitor Test

- a. Select "MONITOR TEST" on the menu screen and press the start button. The following screen is displayed.

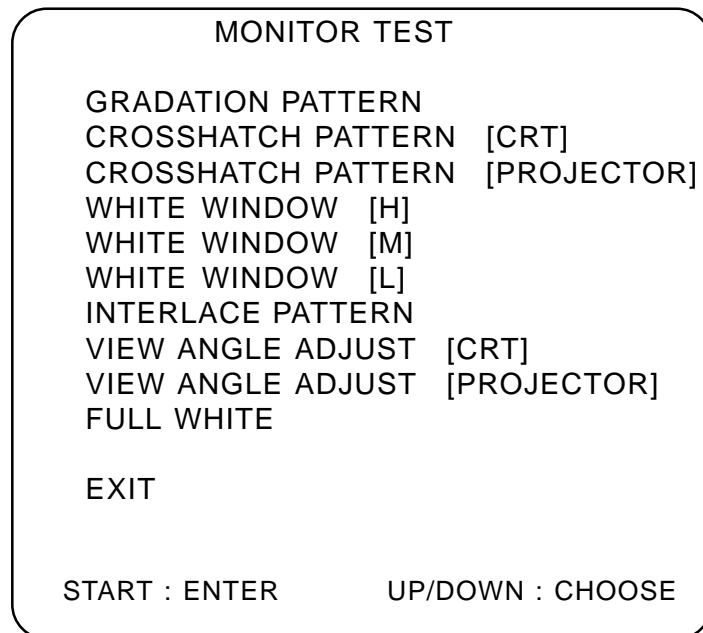

- b. Select an item with the handle bars and then press the start button. Press the start button to exit a selected pattern.

5-3-5 Sound Test

- a. Select "SOUND TEST " on the menu screen and press the start button. The following screen is displayed.

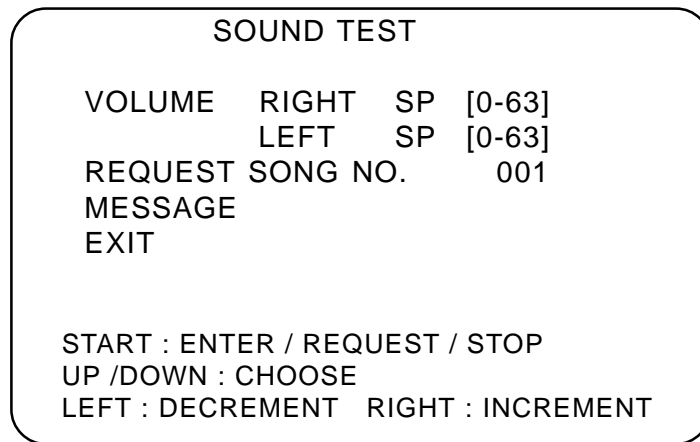

- b. Volume Adjust
Move the handle bars up or down to select the item to be changed, and then move the handle bars left or right to change the setting of the selected item. (0 is the quietest / 63 is the loudest.)
- c. Sound Output Test
Each digit of the REQUEST SONG NO. can be selected by moving the handle bars up or down. Moving the handle bars left or right will change the number.
Each number will produce a different sound when the start button is pressed.
001 will produce a stereo test. First a tone will be produced from the left speaker, then from the right speaker and then from both speakers.
- d. Select "EXIT" and press the start button to return to the menu screen

5-3-6 ADS Data

Select "ADS DATA " on the menu screen and press the start button.

The book keeping data for the game will be displayed.

5-3-7 OTHERS

Select "OTHERS" on the menu screen and press the start button.

This screen is used to test the PCB and to reset the game to factory settings.

6. INITIALIZATION

Adjustments When Replacing Parts (Initialization)

The following adjustments should always be performed after replacing the game PC board, ROM, Steering Assy, Pedal Assy, or Control Pots.

The game will not operate correctly if these adjustments are not made.

- a) Ensure that handle bar assembly is in the neutral position by keeping your hands away from the assembly.
- b) Slide the test switch "ON" while pressing the service switch. The following screen will be displayed on the monitor.

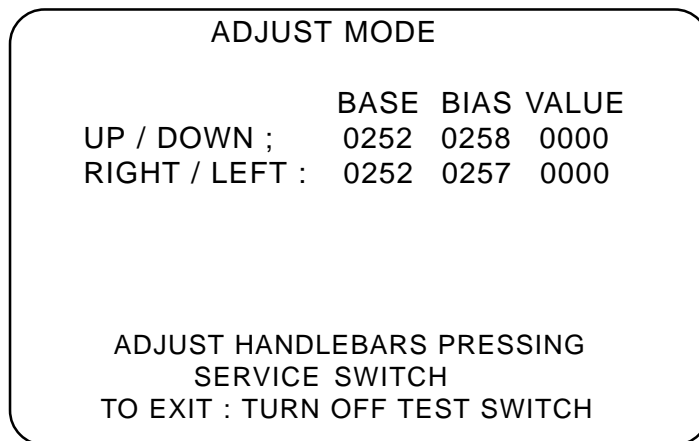

- c) Press the service switch to reset all values to 0000 or FFFF
- f) Slide the test switch "OFF" to return to normal game mode.

Note: If the above initialization does not perform correctly, repeat two or three times.

7. MAINTENANCE

Maintenance and repair should only be carried out by competent persons.

WARNING

- Do not make any alterations to this machine without prior approval. Doing so could cause unforeseeable danger.
- Only parts specified by Namco Europe Ltd. should be used when replacing or repairing parts (including screws).
- Ensure that power to the machine is turned OFF before commencing any maintenance work (troubleshooting, repairs etc.)
- If performing work not described in this manual, be sure to contact your distributor for instructions as no responsibility will be accepted for damage or injury.
- Parts of the power supply and projector monitor remain hot and carry high voltage even after switching OFF and could cause burns or electric shock. Take care not to touch these parts accidentally.
- Make sure that the machine is switched OFF before connecting or disconnecting any plugs or connectors.
- When removing the mains plug from the wall outlet, always grasp the plug not the cable.

7-1 Pedal Pressure Adjustment

This game is designed so that the pedal pressure can be adjusted. This will have an effect on the difficulty of the game.

At the time of shipment, the pressure is set to a light setting.

The mechanism becomes uncovered so take care not to trap hands or fingers in the mechanism

- 1) Remove the four security screws (M5x12) and remove the upper cover.
- 2) Remove five security screws (M5x20) and four security screws (M5x12) and remove the right side cover.

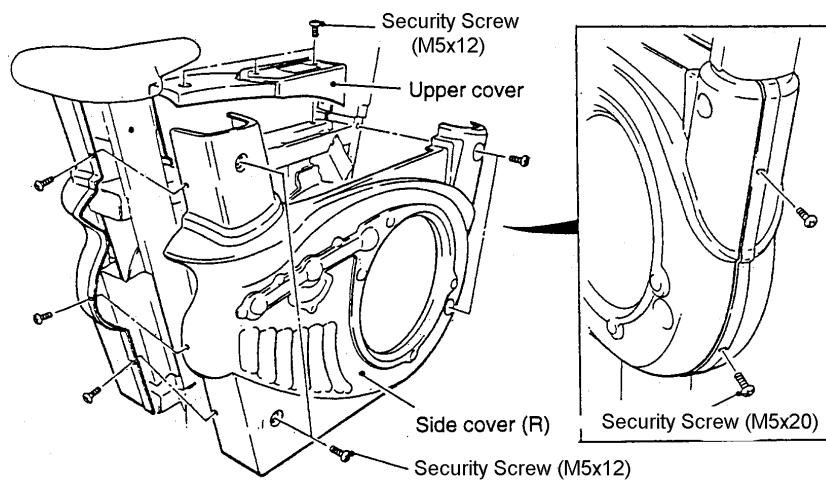

- 3) To change the pedal pressure, loosen the truss screw (M5x12 Pozi) and move the magnet unit. The pressure becomes less when the magnet unit is moved away from the flywheel, and heavier when it is moved towards the flywheel. Check the pressure by pedalling each time the magnet unit is moved. When the required pressure is achieved, fully re-tighten the truss screw.

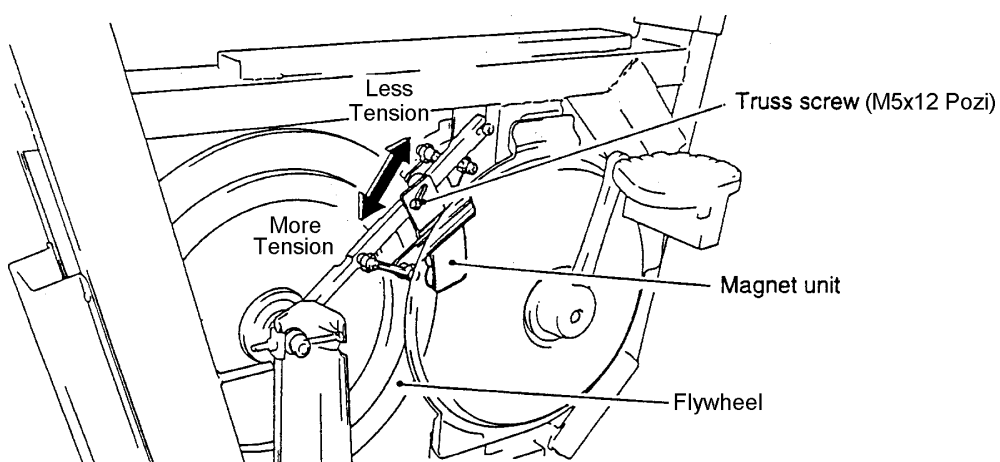

- 4) Refit the side and top covers.

7-2 Inspecting or Adjusting the Drive Belt

The mechanism becomes uncovered so take care not to trap hands or fingers in the mechanism

- 1) Remove the three security screws (M5x12) and remove the upper cover.
- 2) Remove five security screws (M5x20) and four security screws (M5x12) and remove the right side cover.

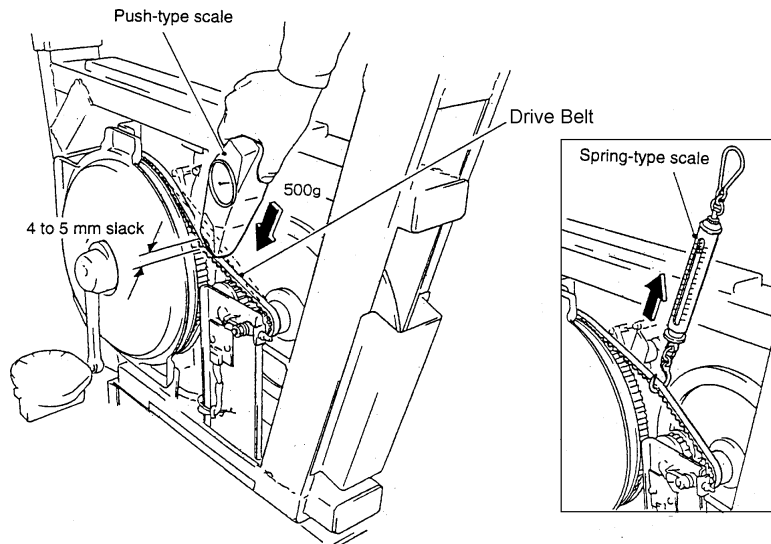

- 3) Press the centre of the belt with a push type scale, or pull the centre of the belt with a spring type scale. The drive belt should have 4 to 5mm slack when a force of 500g is applied. If there is more or less slack, the belt needs adjustment.

6-2-1 Adjusting the Drive Belt

- 1) Remove the top and right side covers as above.
- 2) Remove four security screws (M5x12) and remove the left side cover.
- 3) Slacken the two hexagonal flange nuts (3/8"), one either side, retaining the Flywheel.

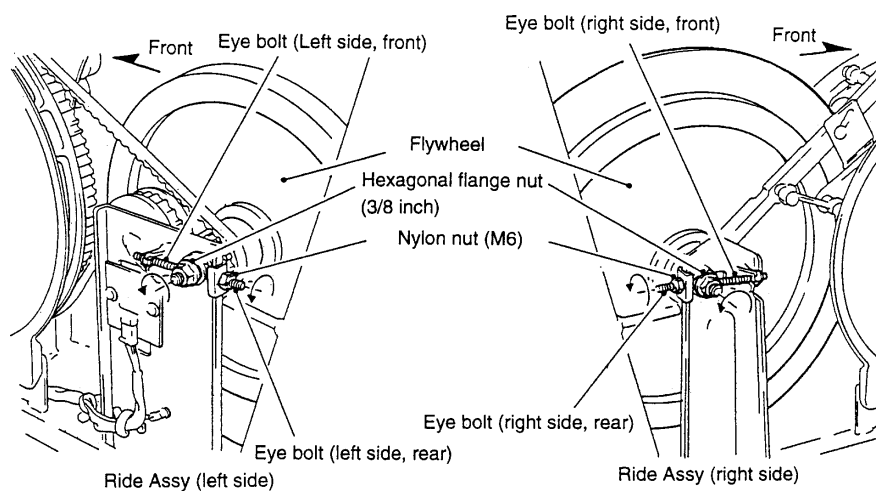

- 4) To increase the tension, slacken the front nylon nuts (M6) and tighten the rear nylon nuts (M6). To decrease the tension, slacken the rear nuts and tighten the front nuts.

Note: To ensure that the flywheel remains parallel within the frame, adjust each nut on both sides by the same amount.

- 5) After adjustment, turn the pedals three or four times to ensure that the drive belt remains central across all pulleys. If the belt drifts off to one side, the flywheel is not parallel and will need adjustment to one side.
- 6) When adjustment is complete, tighten fully all nylon nuts and the two hexagonal nuts.
- 7) Refit the side and top covers.

7-3 Removing the Flywheel or Drive Belt

- 1) Remove the top and side covers, ([see section 7-2](#))
- 2) Remove the security screw (M5x12) and remove the pedal cover on the right hand side.
- 3) Remove the three pozi head screws (M5x12) which fasten the right hand pulley cover. It is not necessary to remove the cover completely.

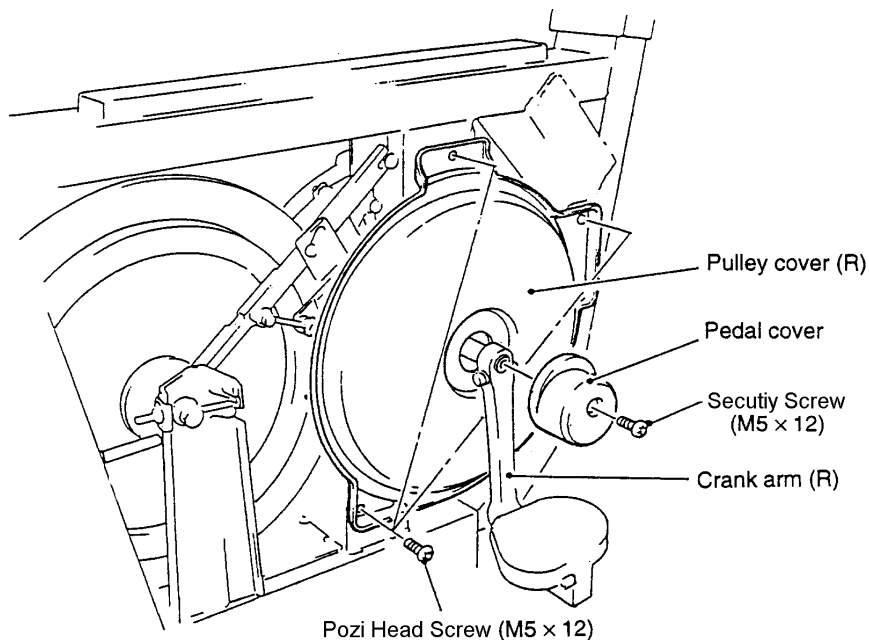

- 4) Remove the four Pozi head screws (M5x12) and remove the wheel cover.

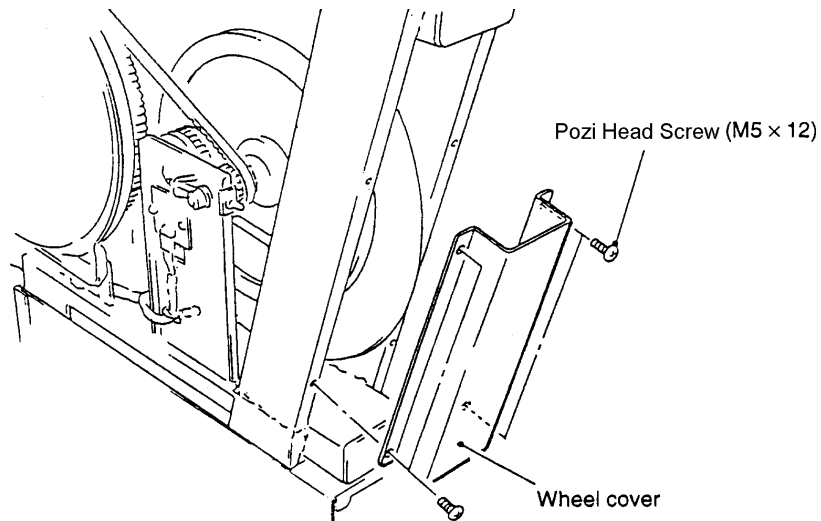

- 5) Remove the hexagonal flange nuts (3/8") on both sides and the four eye bolts which retain the flywheel shaft to the frame assembly.

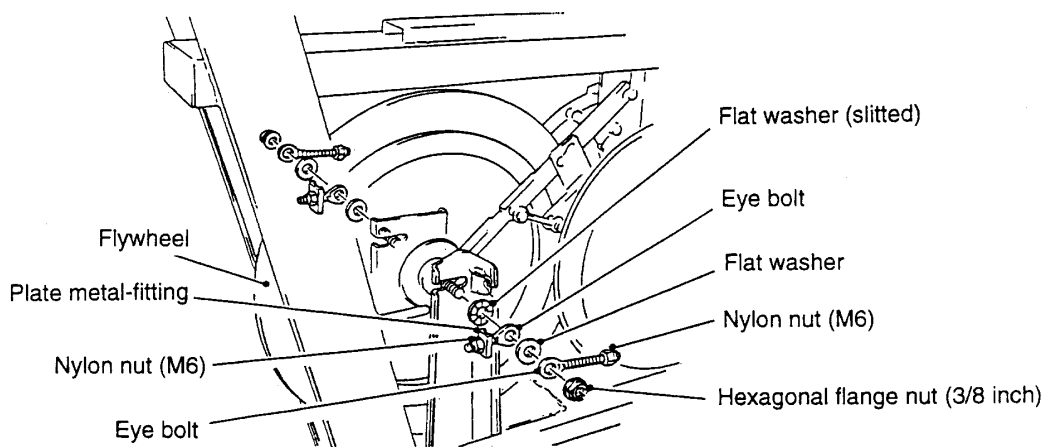

- 6) Move the flywheel forward to release the tension on the drive belt, and slip the drive belt off the pedal pulley.

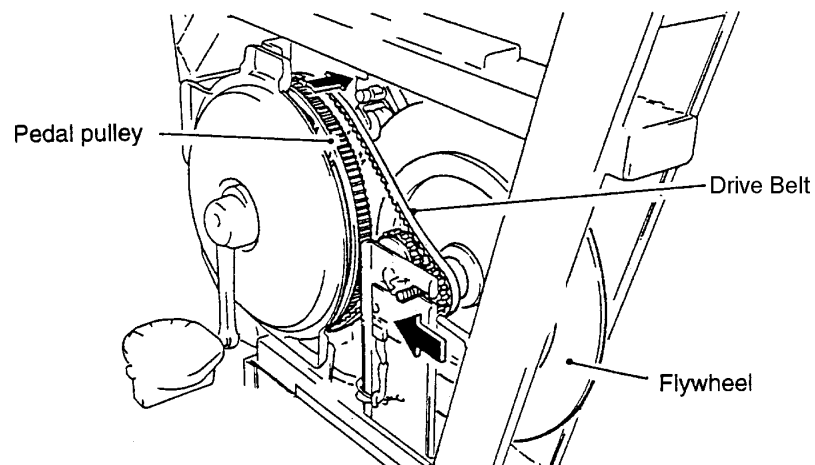

- 7) Move the flywheel back to disengage it from the cycle frame.
Note: When disengaging the flywheel, the link unit will come off the shoulder bolt, so hold it by hand.

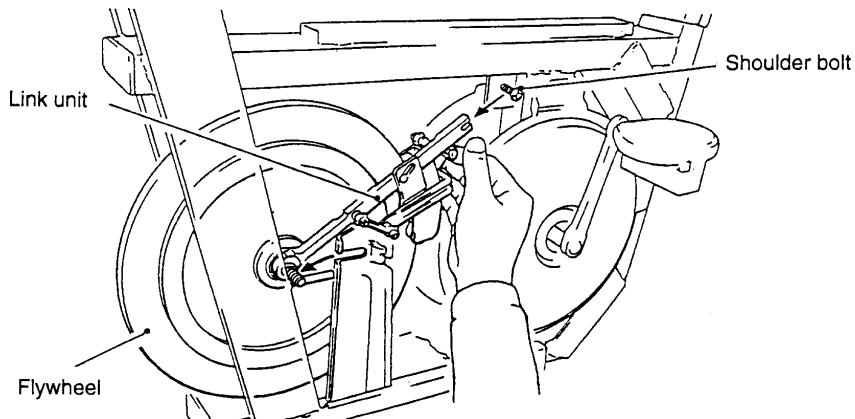

- 8) Lift the flywheel up a little and remove the drive belt from the flywheel pulley.

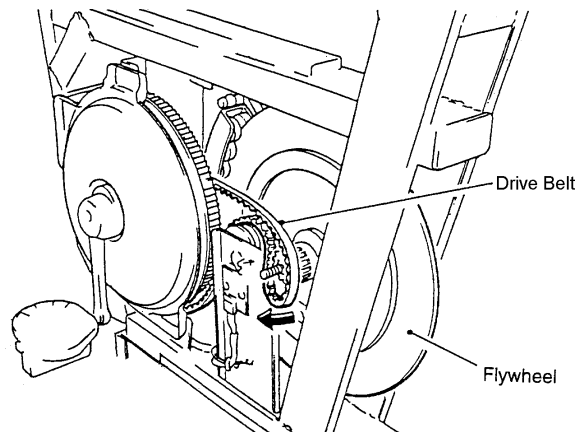

- 9) Remove the flywheel together with the entire link unit by withdrawing the assembly from the right hand side.

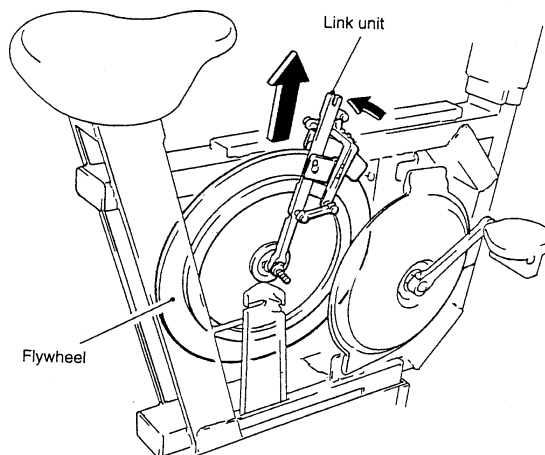

- 10) Re-assembly in reverse order.
Note: When re-assembling, fit the flange nuts and nylon nuts finger tight until the drive belt tension has been adjusted. (see section 7-2-1)

7-4 Inspecting and Replacing the Pedal Sensor Sticker

- 1) Remove the top and left side covers (see section 7-2)
- 2) Remove the two Pozi head screws (M5x10) and remove the sensor PCB.
- 3) Look through the square cut out and make sure that the sensor sticker is not dirty or damaged.
- 4) If the sensor sticker is dirty wipe it with a clean soft, dry cloth. If it is damaged it will need to be replaced.

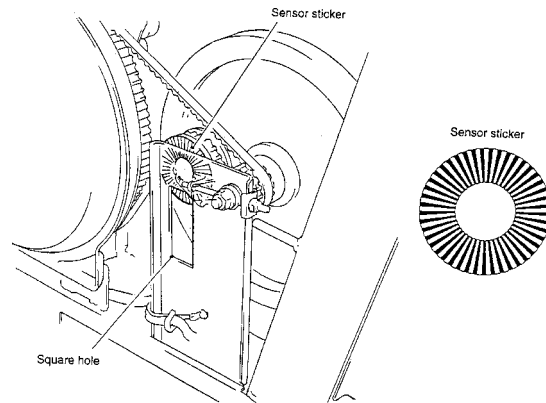

- 5) Remove the flywheel (see section 7-3).
- 6) Remove one nylon nut (3/8") and remove the tension pulley.
Note: There is a thick flat washer and an adjustment flat washer on the tension pulley shaft. Take care not to lose them.

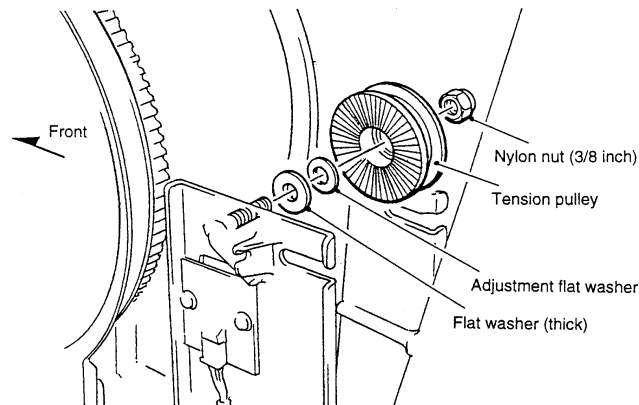

- 7) Peel off the old sensor sticker and replace with a new one. When replacing the sticker ensure that the sensor sticker is central on the tension pulley. If the sticker is off centre by even 1mm the pedal rotation sensor may not read the sticker properly.
- 8) Re-assemble in reverse order.
Note: When re-assembling, fit the flange nuts and nylon nuts finger tight until the drive belt tension has been adjusted. (see section 7-2-1)

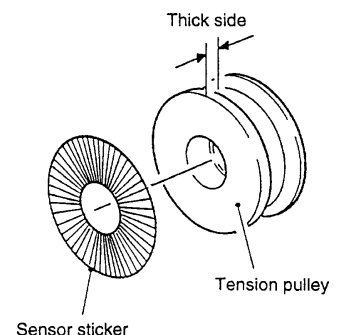

7-5 Replacing the Fluorescent Tube

DANGER; To prevent electric shock, ensure machine is switched OFF before commencing work.

- 1) Remove the ten socket button head screws (M5x12), and remove the side vac-forms. (five screws on each vac-form)
- 2) Remove the two countersunk screws (M5x12) from the bottom of the acrylic.
- 3) Remove the two socket button head screws (M4x25), and remove the header acrylic retaining bracket.
- 4) Remove the header acrylic.

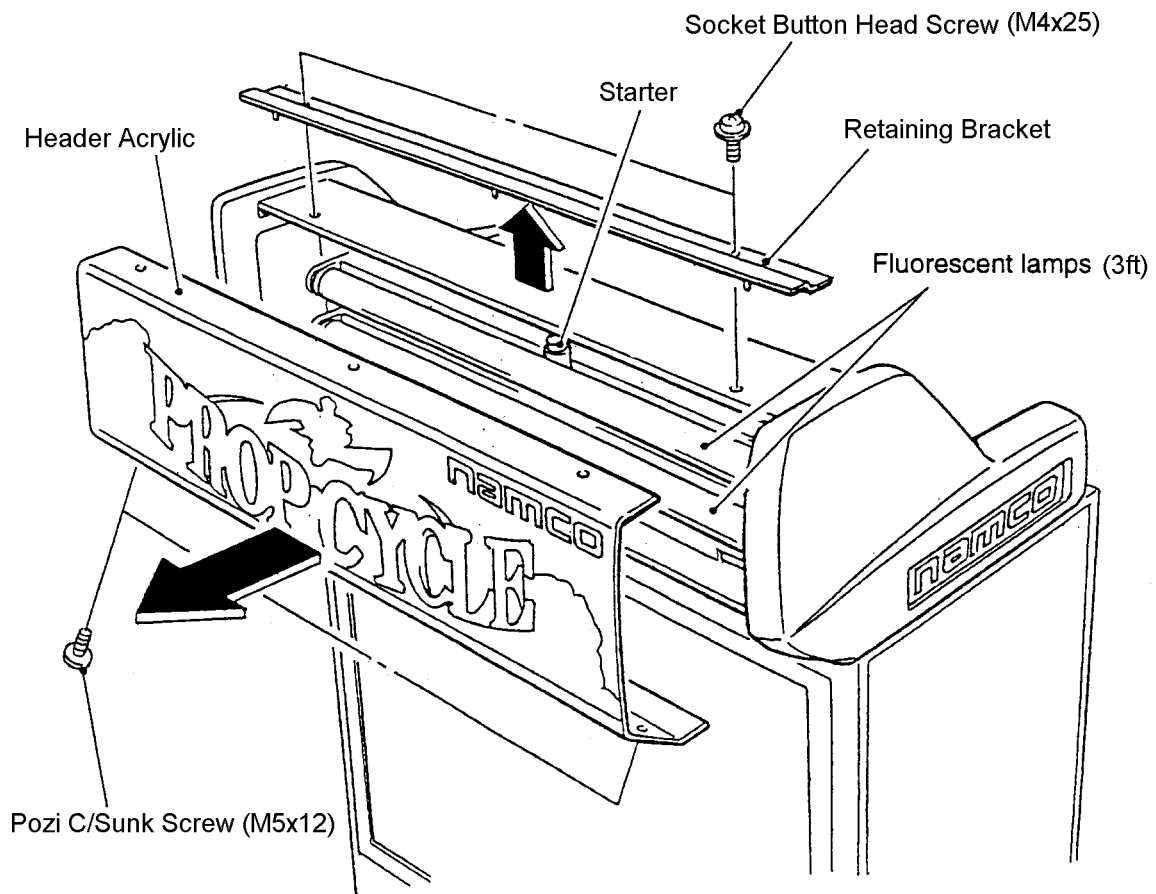

- 5) Replace the fluorescent tube and/or the starter.
- 6) Re-assemble in reverse order.

7-6 Replacing the Fan

Warning: The Front Base Assembly weighs approx. 25kg. It should be handled by at least two people.

- 1) Remove the four security screws (M5x30).
- 2) Disconnect and remove the front base assembly.

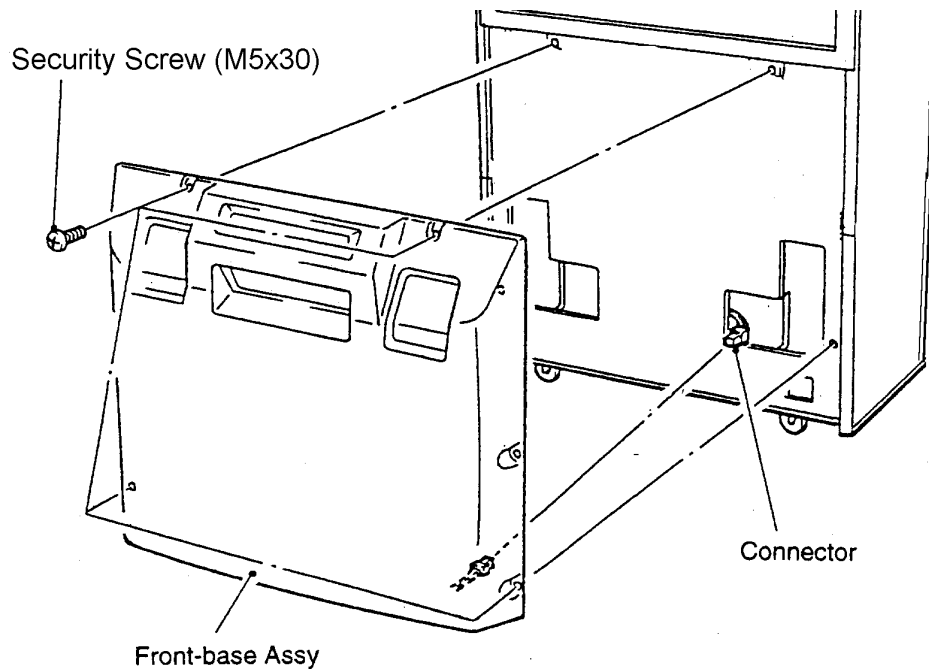

- 3) Remove the four security screws (M5x12) and remove the front cover.

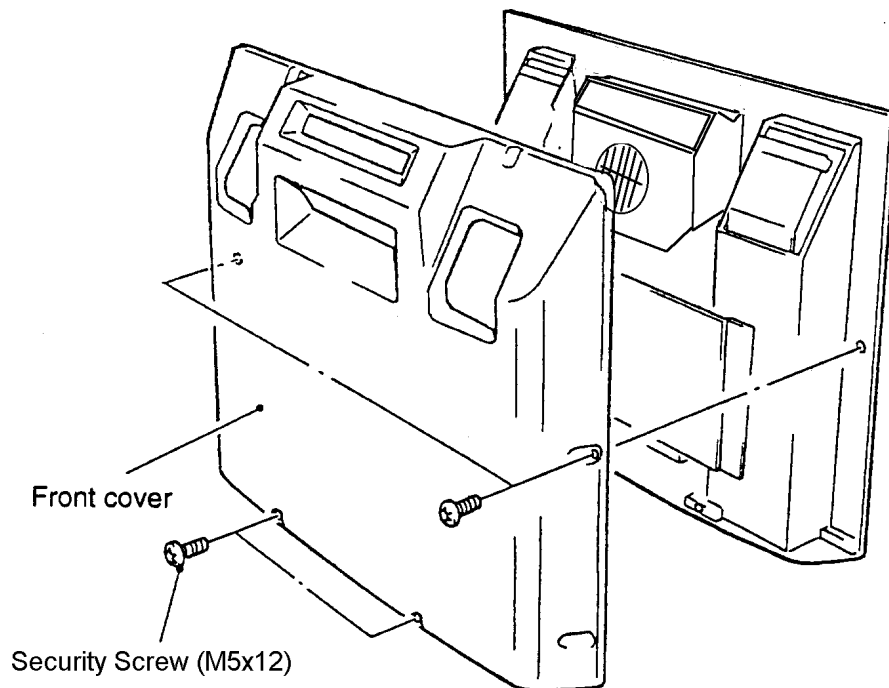

- 4) Remove the three countersunk screws (M5) and remove the fan box front panel.

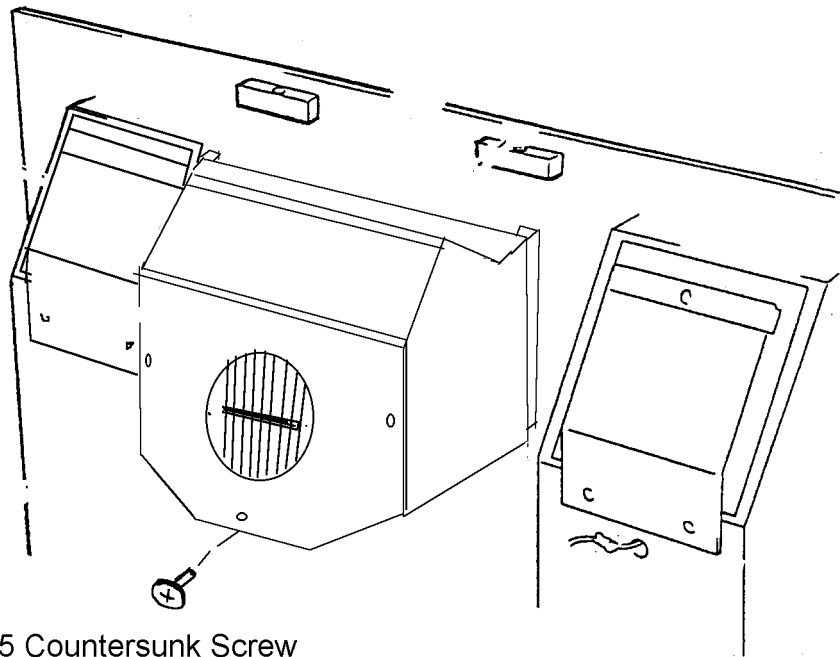

- 5) Remove the four M4 Whizz nuts on the rear of the front base wood and remove the fan from the front.

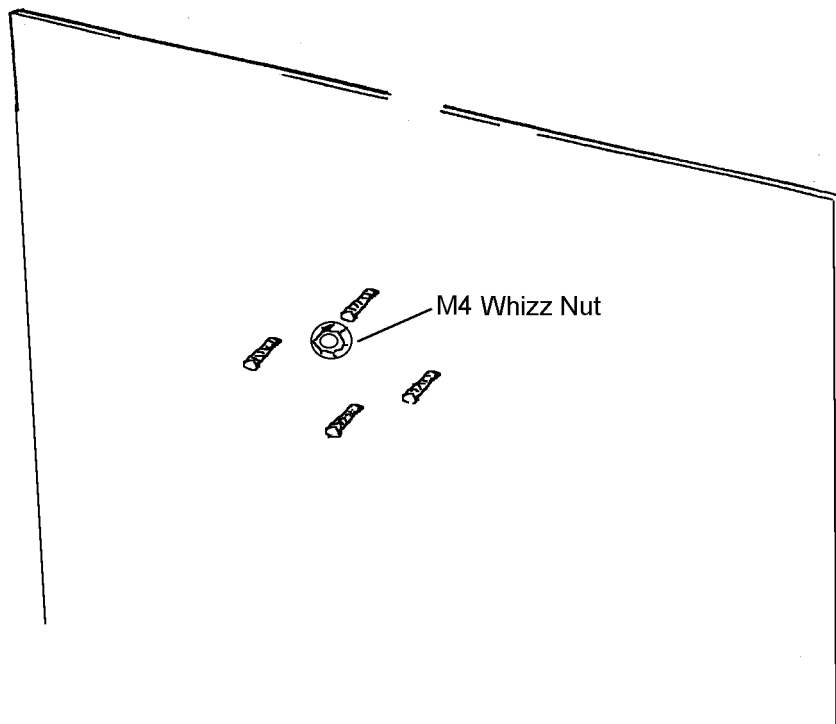

7-7 Replacing the Start Switch

- 1) Remove the three security screws (M5x12) and lift up the control panel hood. Remove the switch and lamp assembly from the start button and remove the control panel hood.
- 2) Replace the switch or lamp.
Note : When replacing the switch ensure that the wires are replaced to the correct terminals.

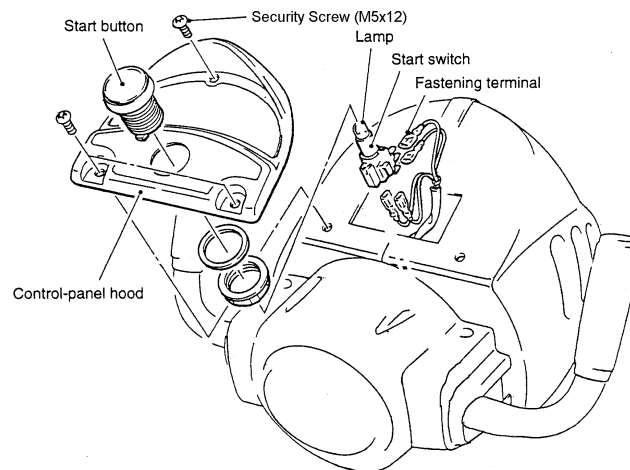

7-8 Removing the Handle Covers

- 1) Remove the control panel hood ([see section 7-7 above](#))
- 2) Remove the five security screws (M5x12) and remove the handle cover (Remove either one of the screws on the bottom of the handle.)

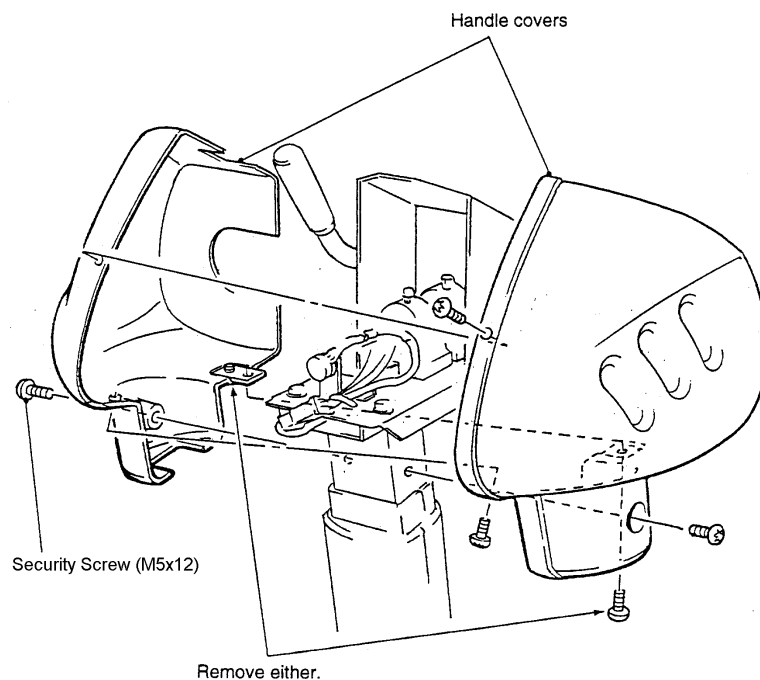

7-9 Replacing the Handle Assembly

- 1) Remove the handle cover. (see section 7-8)
- 2) Remove the two Pozi head screws (M5x12) with flat and spring washers and remove the control panel base.

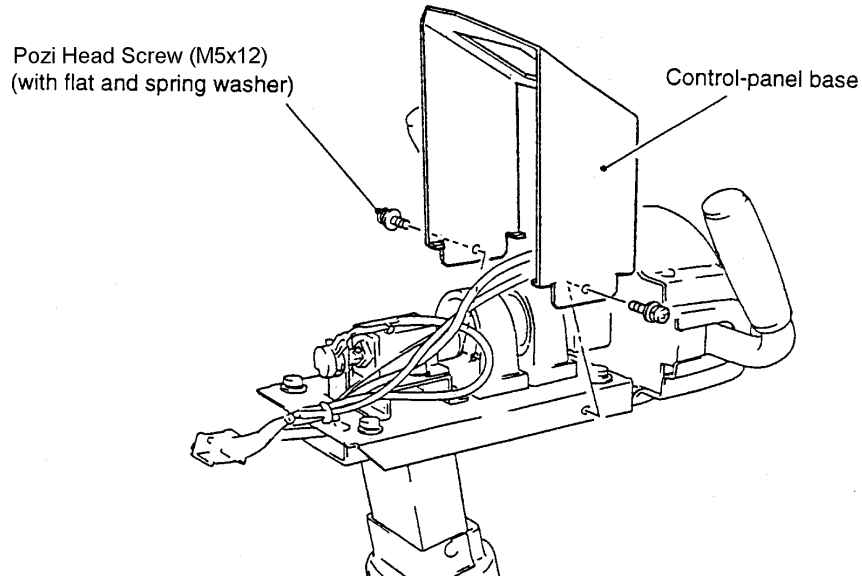

- 3) Dis-connect the handle assembly connector.
- 4) Remove the four Hex head set screws (M8x16) and remove the handle assembly.

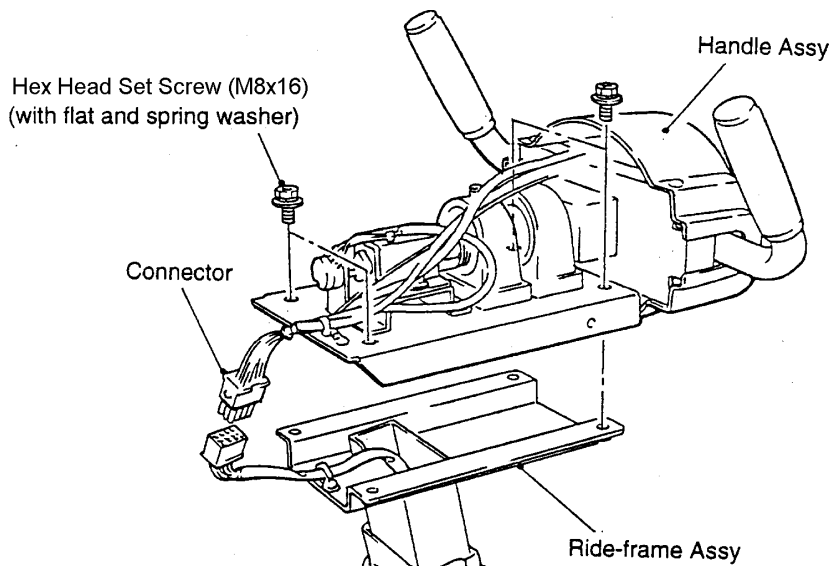

- 5) Refit in reverse order.

Important: After replacing the handle assembly be sure to re-initialize the machine. (See section 6)

7-10 Replacing the Handle Pots.

7-10-1 Replacing the Up/Down Pot

- 1) Remove the four security screws (M5x12) and remove the front cover

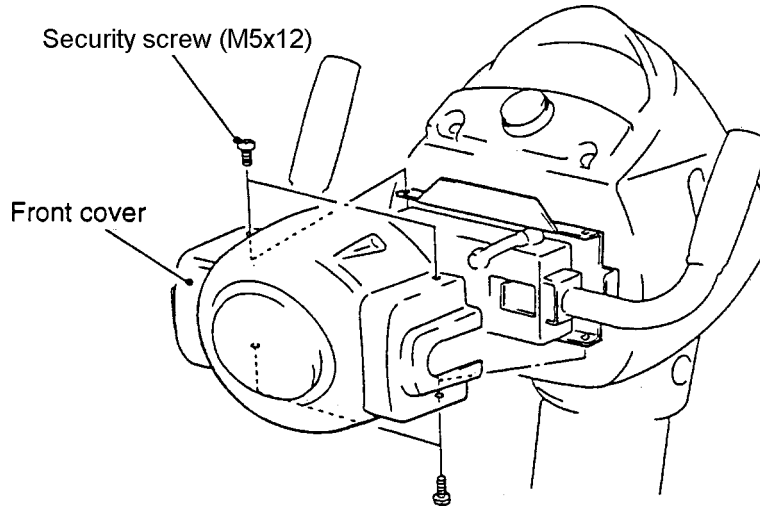

- 2) Remove the three wires from the pot (note position and colour of wires for re-assembly)
- 3) Remove the grub screw (M4x8), then slide the pot bracket (A) to the right and pull it forward to remove it.
- 4) Remove the pot from the bracket and replace with a new one.

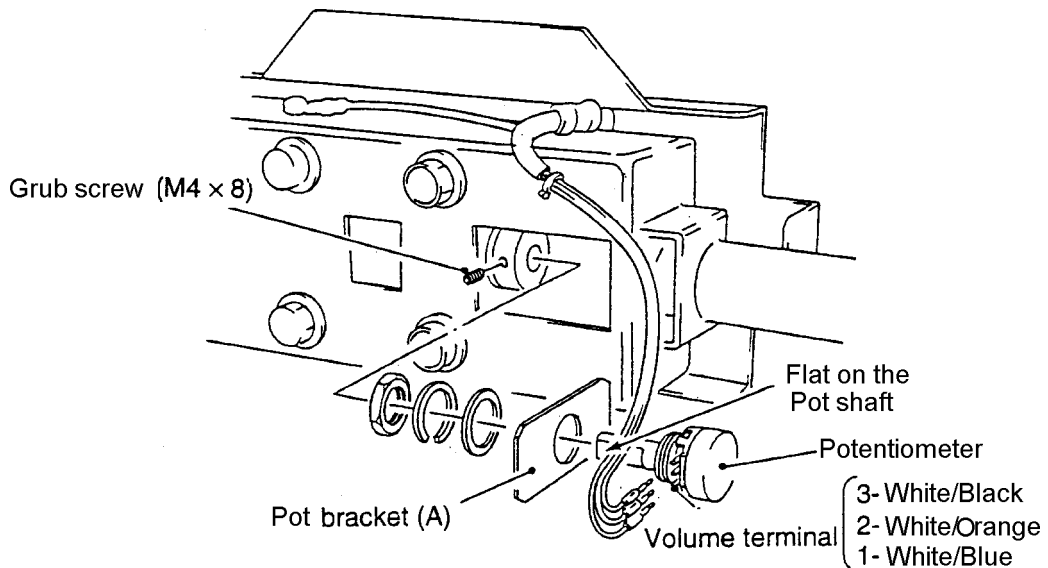

- 5) When replacing the pot, ensure that the grub screw engages on the flat of the pot shaft.

Note: After replacing the pot, ensure that the machine is re-initialized (see section 6)

7-10-2 Replacing the Left/Right Pot

- 1) Remove the handle cover. (see section 7-8)
- 2) Remove the wires from the pot. (note position and colour of wires for re-assembly)
- 3) Remove the grub screw (M4x8)
- 4) Remove the pot from the pot bracket (B) and replace with a new one.

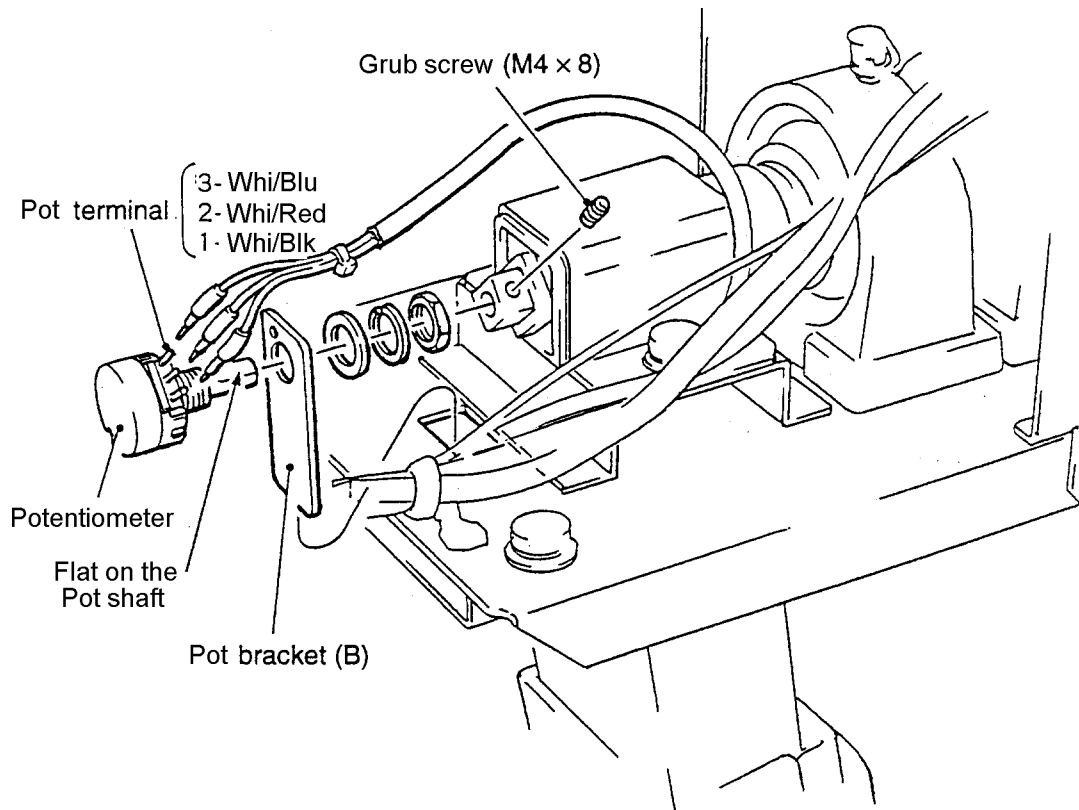

- 5) When replacing the pot, ensure that the grub screw engages on the flat of the pot shaft.

Note: After replacing the pot, ensure that the machine is re-initialized (see section 6)

7-11 Replacing the Pedals

- 1) Remove the security screw (M5x12) and remove the pedal cover.

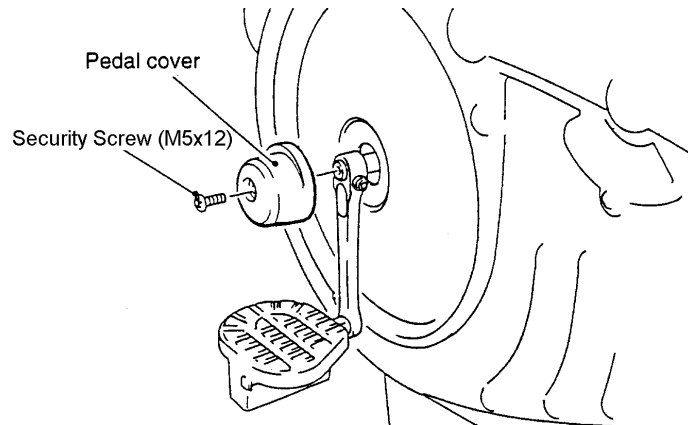

- 2) Loosen the nylon nut (M6) on the crank pin ensuring that no threads are protruding through the nut. (If any thread is protruding, the thread may be damaged in the following step).

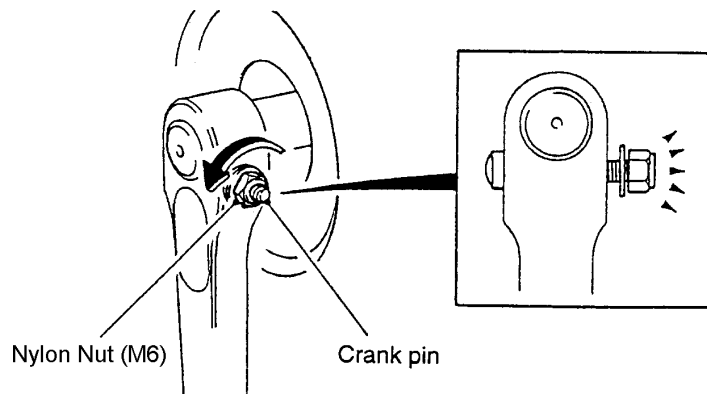

- 3) Turn the pedal so that the nylon nut is at the top. Holding the pedal firmly tap the nut with a hammer to release the crank pin. Once the crank pin has been released the nylon nut can be removed and the crank pin withdrawn.

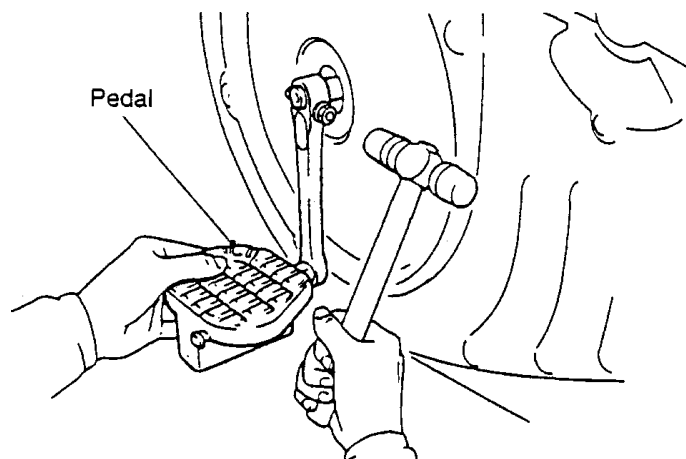

- 4) When re-fitting, the crank pin should be inserted from the front (monitor side) when the pedal is directly downward.
- 5) The crank arm moves 2 ~ 3mm in and out on the shaft when the crank pin is inserted. Move the crank arm to the outside and tighten the nylon nut (M6)

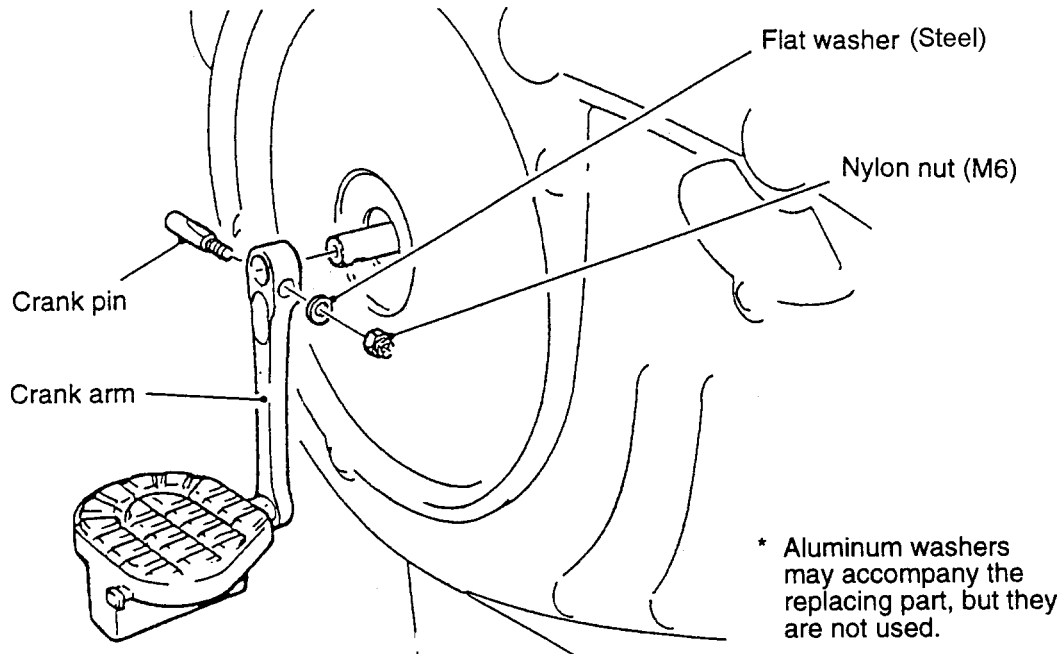

NOTE: If the nylon nut (M6) is over tightened damage may occur to the crank arm. Tighten only so that there is no play of the crank arm on the shaft.

- 6) Refit the pedal cover.

7-12 Replacing the Vibration Proof Rubbers

- 1) Remove the two security screws (M5x12) and remove the joint cover.
- 2) Disconnect the connector and remove the three hex head screws (M12x25).

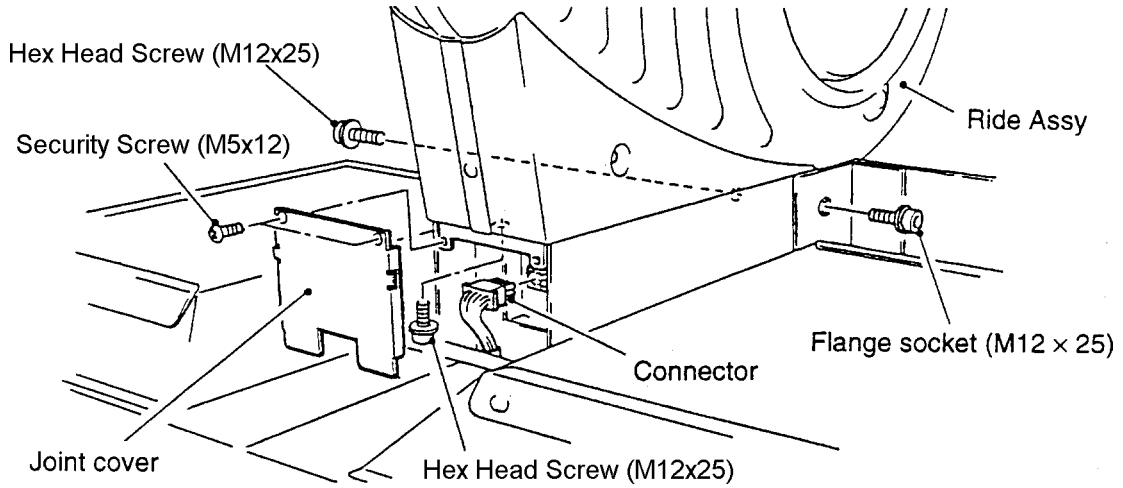

- 3) Lift the cycle assembly straight up and remove from the base assembly.

NOTE: The cycle assembly weighs approx. 45kg. Ensure that at least two people are used to remove the cycle assembly. When replacing the cycle assembly take care not to trap hands or fingers.

- 4) Remove the ten security screws (M5x12) and remove the steps.
- 5) Remove the four pozi head screws (M5x12) and remove the slide and slide base.

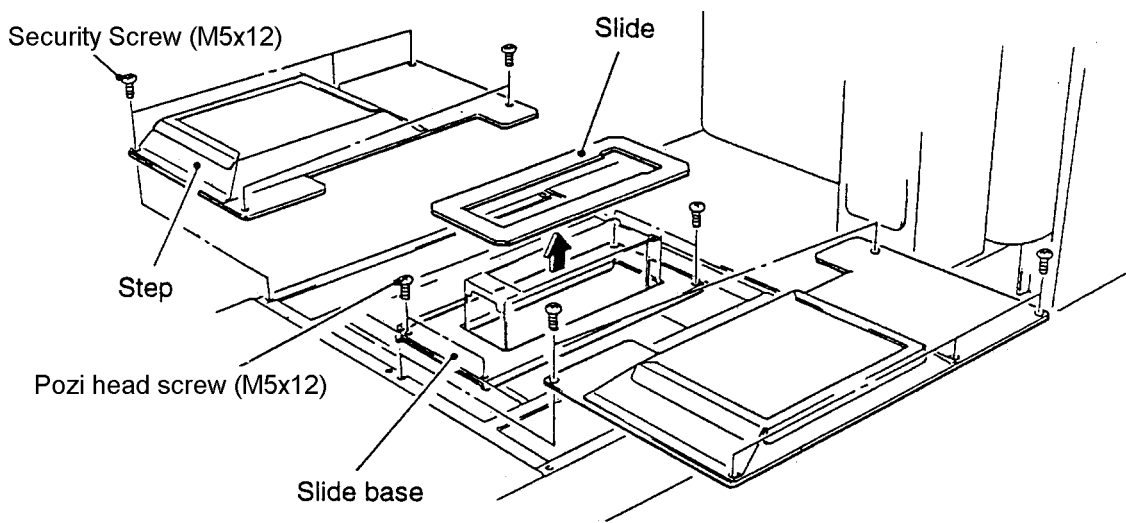

- 6) Remove the eight hex head bolts (M10x25) (with spring and flat washers) and remove the joint base.

NOTE: The joint base weighs approx. 20kg so be careful when installing or removing it.

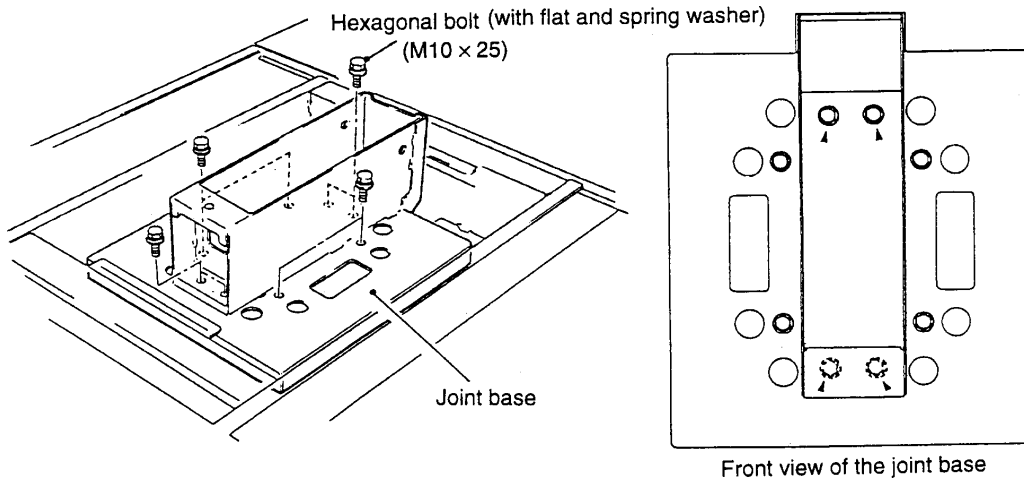

- 7) Remove the four hex nuts (M12), spring washers (M12) and flat washers (M12) and remove the joint spacer.
- 8) Remove the four hex head screws (M10x35) (with flat and spring washers) and remove the cross link.

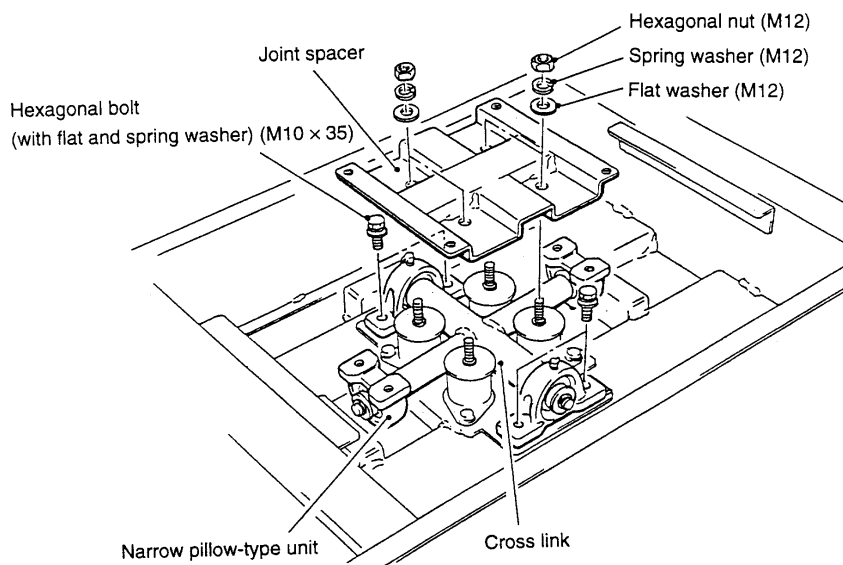

NOTE: The narrow pillow-type unit rotates. When attaching it to the joint base, make sure the installation holes are facing up as shown in the figure above.

- 9) Remove the two hex head bolts M10x25) (with spring and flat washers) and remove the vibration proof rubber.

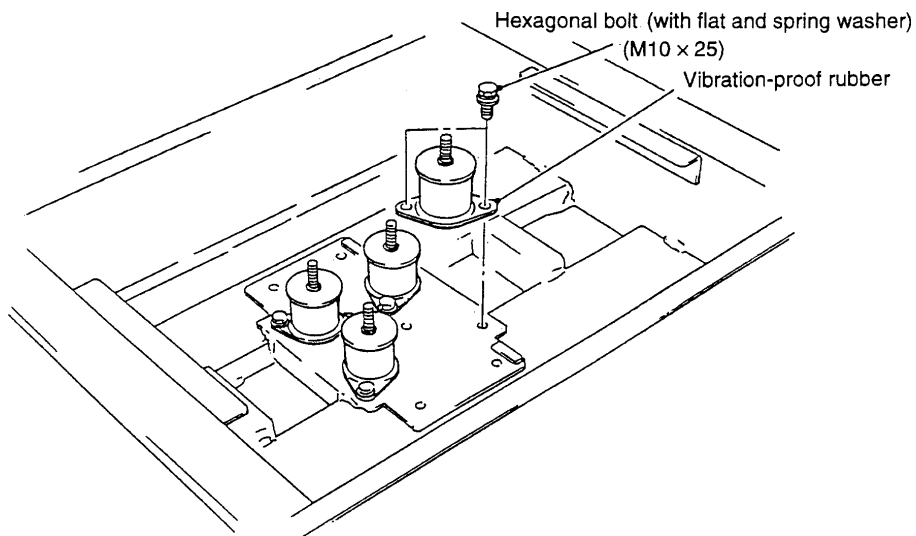

- 10) Replace the vibration proof rubber and re-assemble in reverse order. When installing the cross link, press the bearing against the positioning plate to position it in the forward and backward direction. To position it in the left to right direction, visually place the cross link so that it is nearly in the centre.

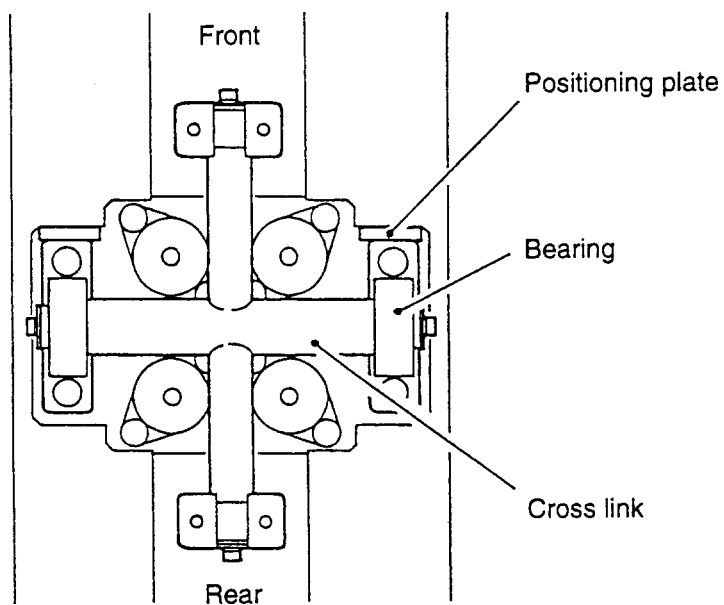

7-13 Replacing the Rubber Stoppers

- 1) Remove the joint base as described in section [7-12](#).
- 2) Remove the hex nut and spring washer (M8) and remove the rubber stopper.
- 3) Replace the rubber stopper and re-assemble in reverse order.

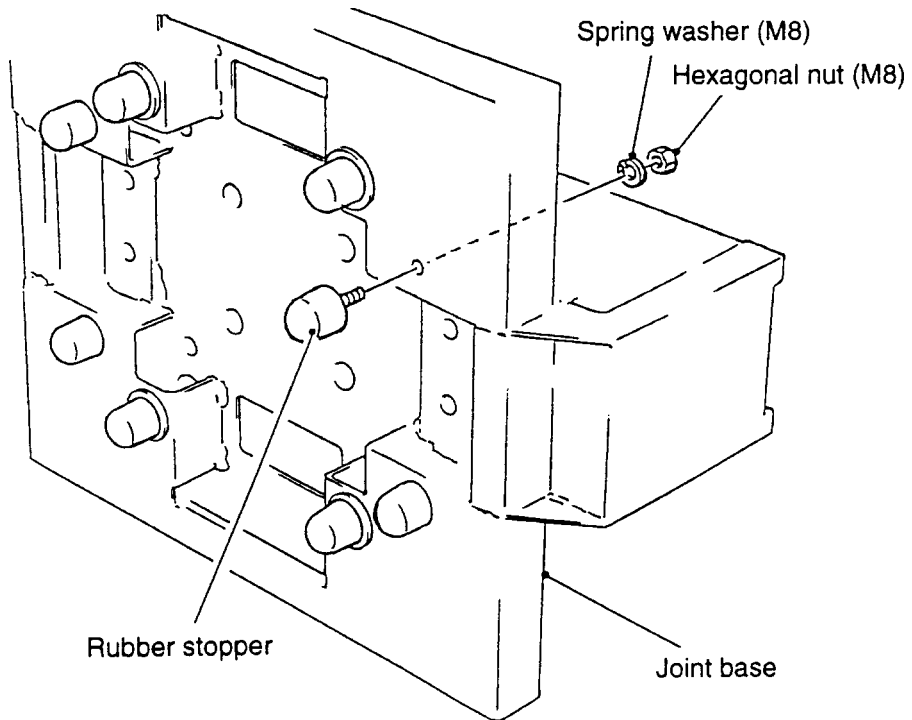

8. PARTS LIST

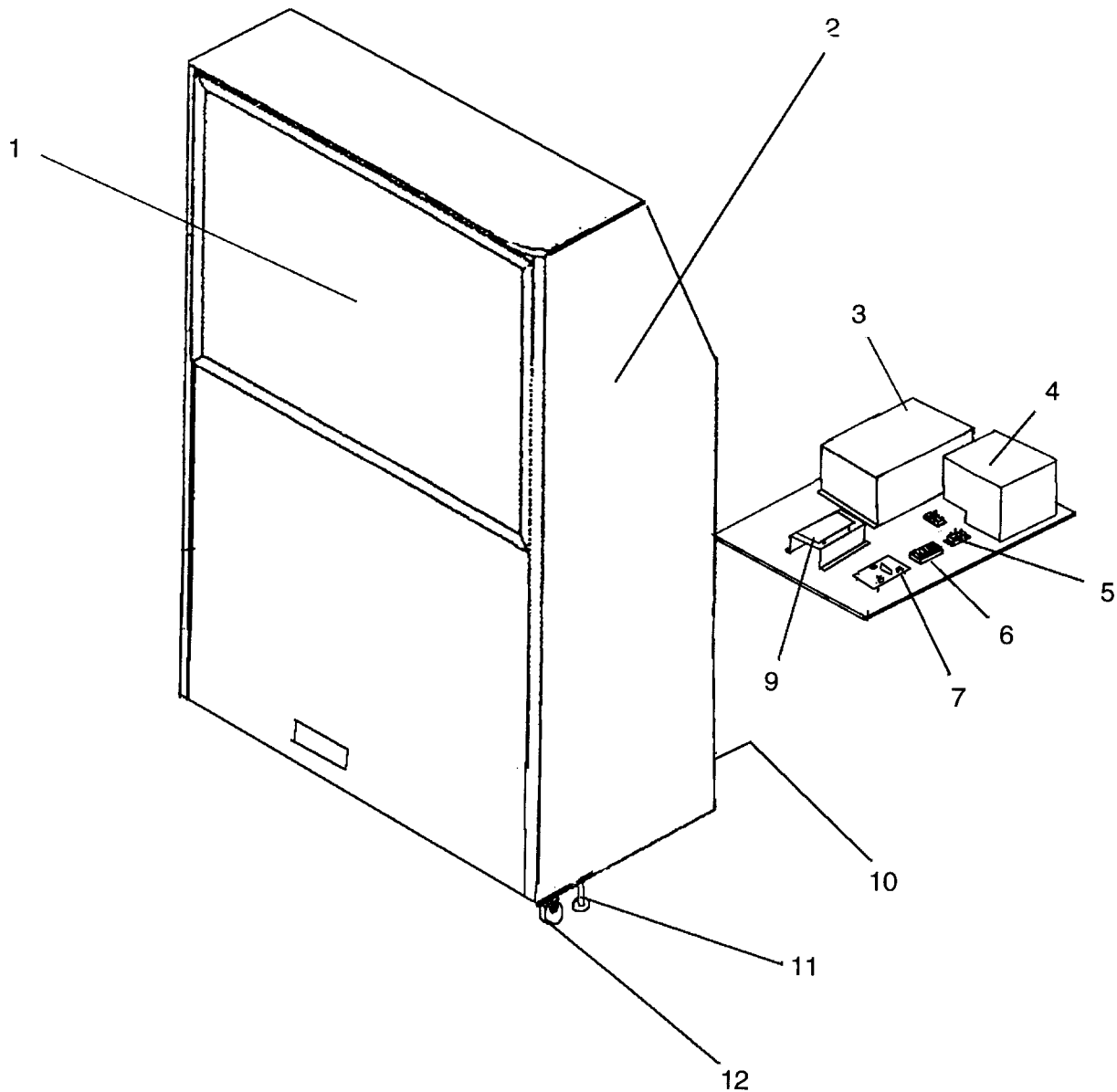

ITEM	DESCRIPTION	PART No
1	Thomson 52" Projector Monitor	84000030
2	Projector Cabinet Side Decal - LHS	40000341
	Projector Cabinet Side Decal - RHS	40000369
3	Prop Cycle PCB Assy - System S22	XPC-PCB
4	SMPSU 5v/30A - Astec 301-3400	83000001
5	Elkay Block 5way	66000014
6	Fuse 1¼" 2amp Slo-Blo	63500506
	Fuse 1¼" 3amp Q/B	63500544
7	Lamp Driver PCB Assy - Single Channel	46000020
9	3 Channel Power Amplifier Assy (vers 2)	46000036
10	Schaffner Mains-In Filter Assy	66000016
11	Adjustable Foot M16 x 95mm	88300079
12	Swivel Castor 75mm	59000005

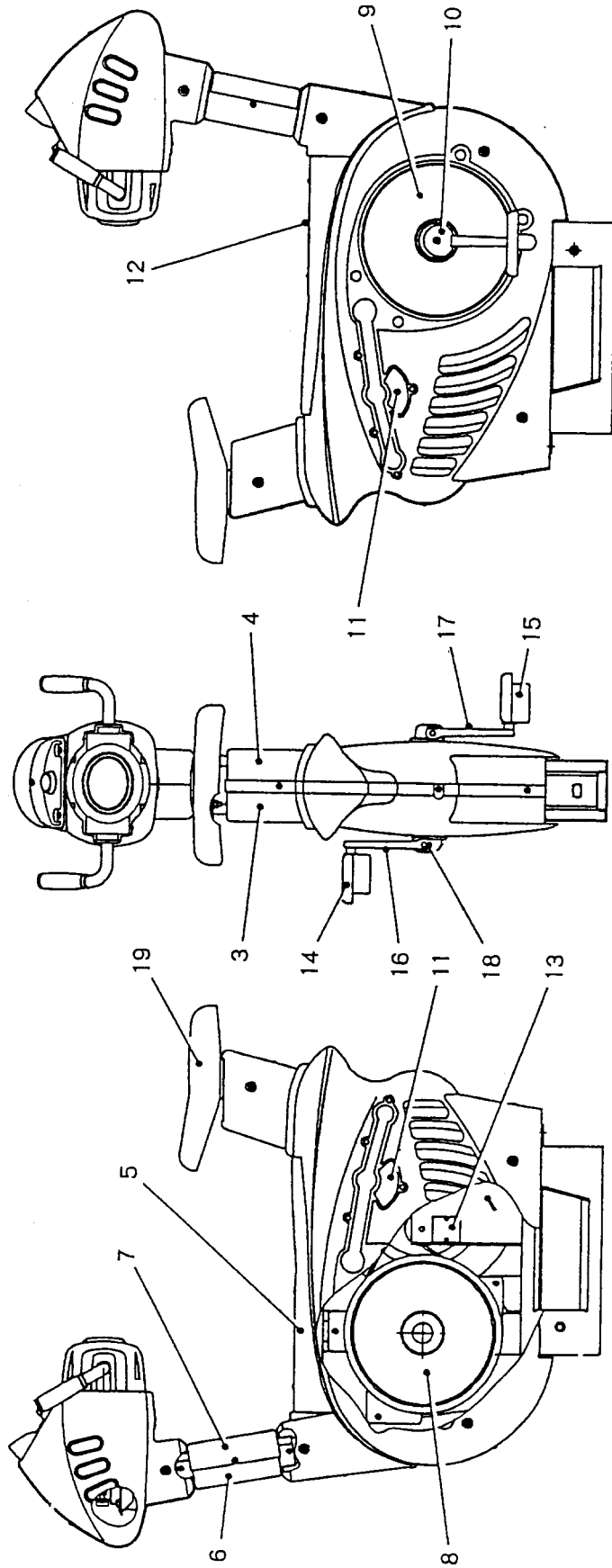

ITEM	DESCRIPTION	PART No
3	Side Cover - LHS	45000977
4	Side Cover - RHS	45000978
5	Crossbar Vac-Form	45000979
6	Handlebar Stem Vac-Form - Front	45000980
7	Handlebar Stem Vac-Form - Rear	45000981
8	Pedal Side Vac-Form - LHS	45000982
9	Pedal Side Vac-Form - RHS	45000983
10	Pedal Cover Vac-Form	45000984
11	Side Indicator Decal	40000347
12	Crossbar Warning Decal	40000348
13	Encoder PCB	XPC-Encoder-PCB
14	Pedal - LHS	XPC-Pedal-LHS
15	Pedal - RHS	XPC-Pedal-RHS
16	Crank Arm - LHS	XPC-Crankarm-LHS
17	Crank Arm - RHS	XPC-Crankarm-RHS
18	Cotter Pin	XPC-Cotterpin
19	Seat	XPC-Seat

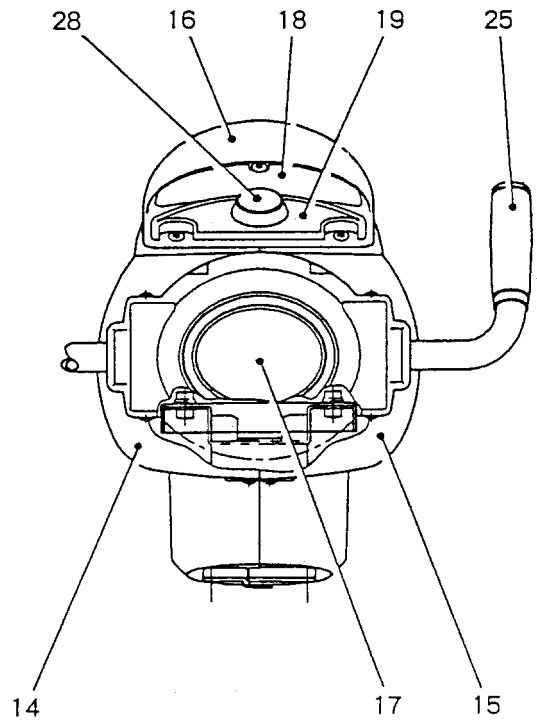
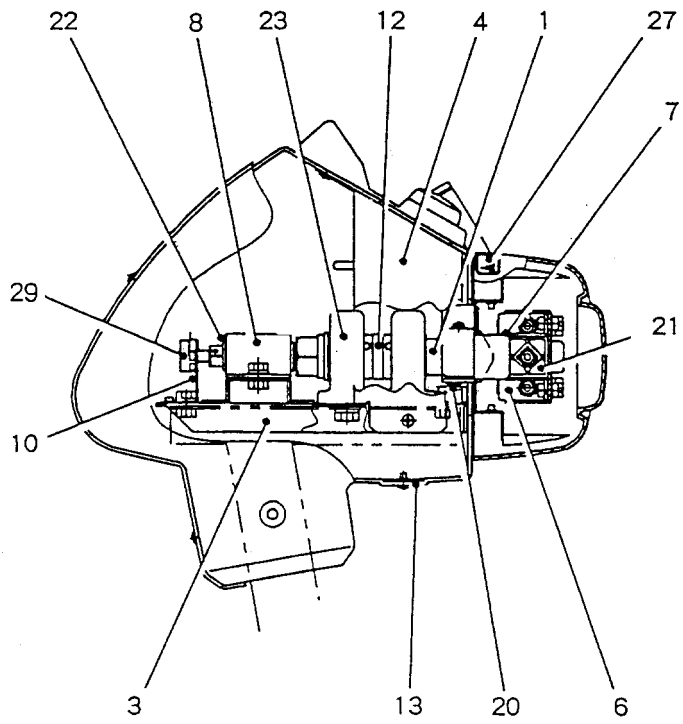
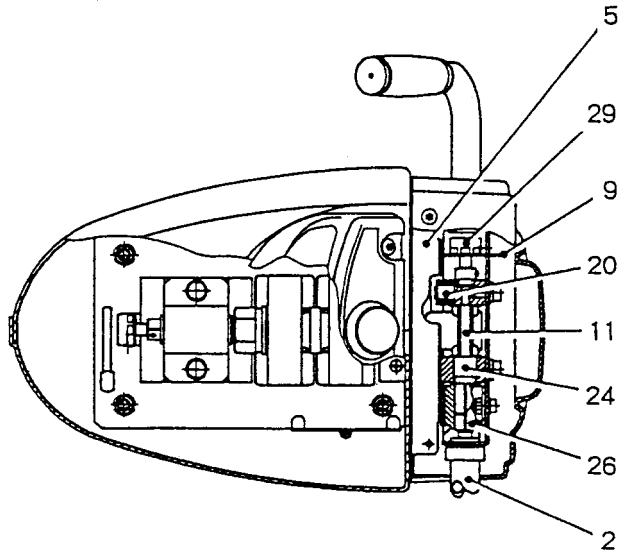

ITEM	DESCRIPTION	PART No
1	Steering Shaft	45000954
2	Handlebars	45000955
3	Steering Base	45000957
4	Switch Support Bracket	45000956
5	Handlebar Locating Bracket	45000958
6	Handlebar Bearing Block	45000959
7	Rosta Spring Support Bracket 'A'	45000960
8	Rosta Spring Support Bracket 'B'	45000961
9	Height Pot Locating Bracket	45000962
10	Steering Pot Locating Bracket	45000963
11	Hex Spacer	45000964
12	Steering Bearing Spacer	45000965
13	Bottom Fixing Plate - Steering	45000966
14	Steering Housing Vac-Form - LHS	45000967
15	Steering Housing Vac-Form - RHS	45000968
16	Steering Switch Vac-Form	45000969
17	Handlebar Cover Vac-Form	45000970
18	Speed Decal	40000345
19	Switch Decal	40000346
20	Movement Stop Bumper	45000971
21	Rosta Spring DR-S18x30	45000573
22	Rosta Spring DR-S18x50	45000574
23	Pillow Bearing UCPA205	45000974
24	Bearing - Oilite LFF-1615	45000975
25	Handlebar Grip and Plug	45000976
26	Rosta Key	46000037
27	Handlebar Warning Decal	40000371
28	Start Switch - Red MCPB	60200247
29	Control Pot - 1K	X008-023

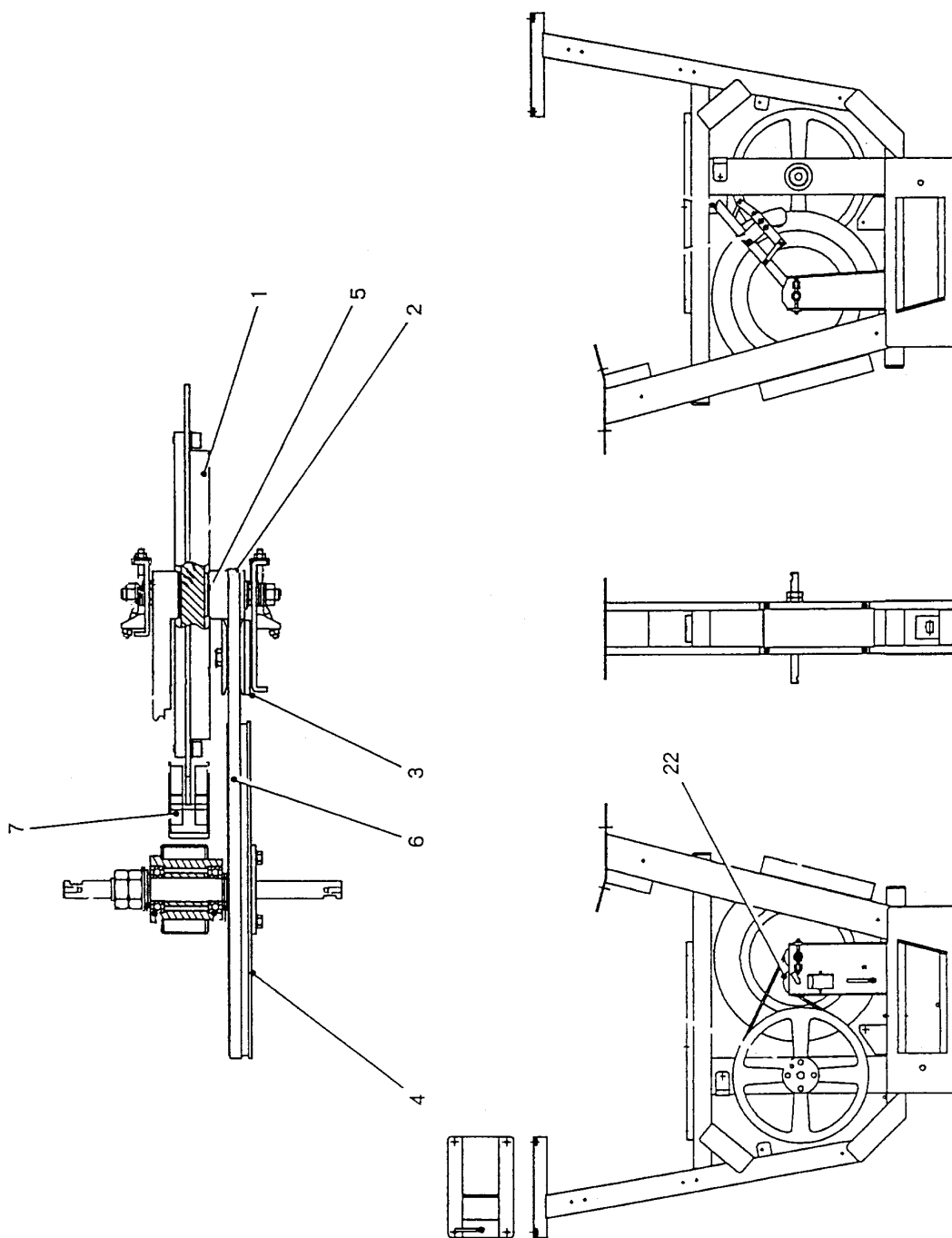

ITEM	DESCRIPTION	PART No
-----	Bike Mechanical Assembly - Complete	XPC-Bike
1	Flywheel	XPC-Flywheel
2	Flywheel Drive Pulley	XPC-Flywhldrvpul
3	Pulley N168-R03A	XPC-Pulley
4	Drive Wheel	XPC-Drivewheel
5	Shim Washer	XPC-Shim
6	Drive Belt N168-R06	XPC-Drivebelt
7	Magnet Holder	XPC-Magnetholder
22	Pedal Speed Encoder Decal	40000344

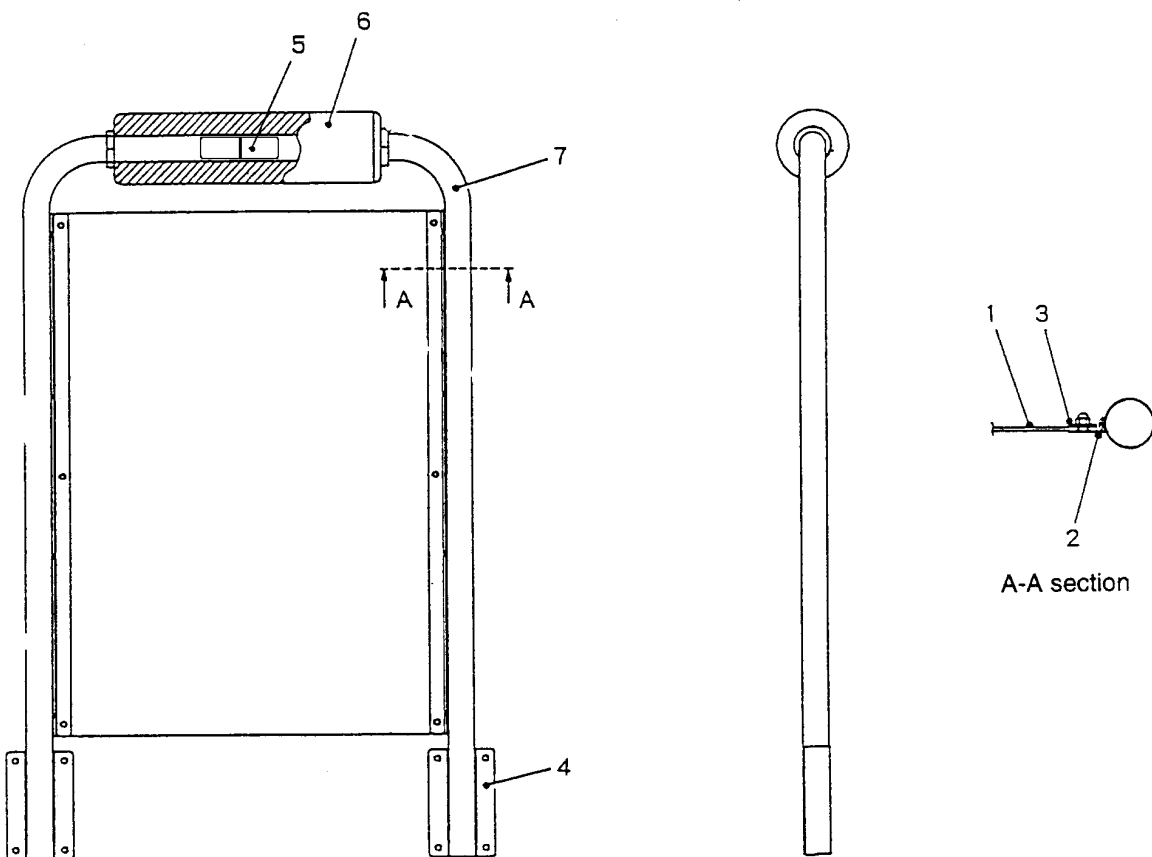

ITEM	DESCRIPTION	PART No
1	Rear Barrier Perspex	39000306
2	Perspex Fixing Bracket	46000009
3	Perspex Fixing Plate	46000010
4	Rear Safety Barrier Clamp	46000014
5	Barrier Pipe Joint	46000012
6	Barrier cushion	46000013
7	Rear Barrier Pipe	46000011

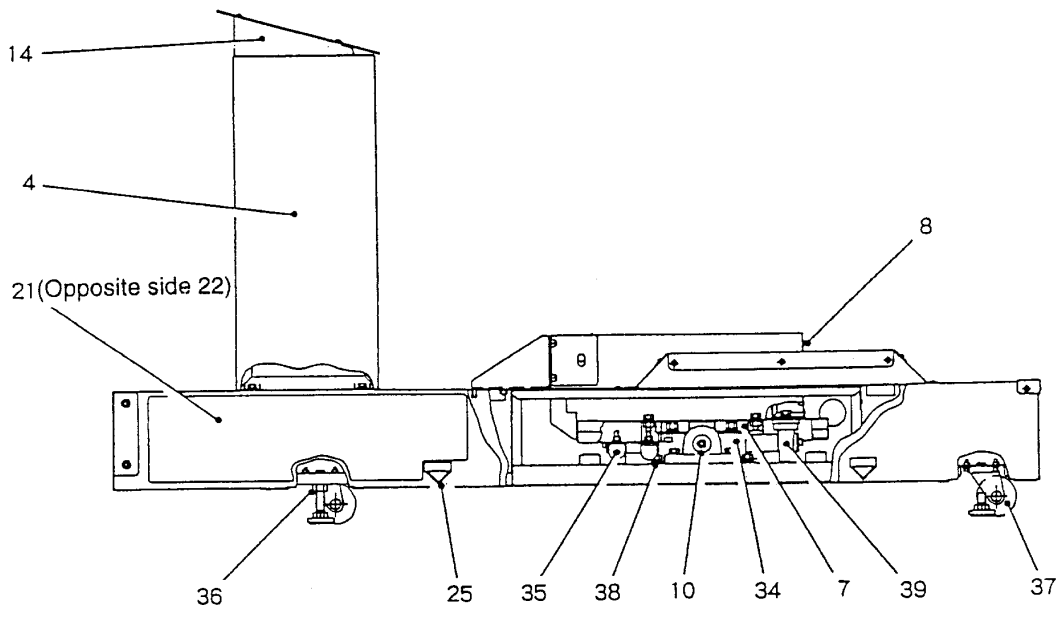
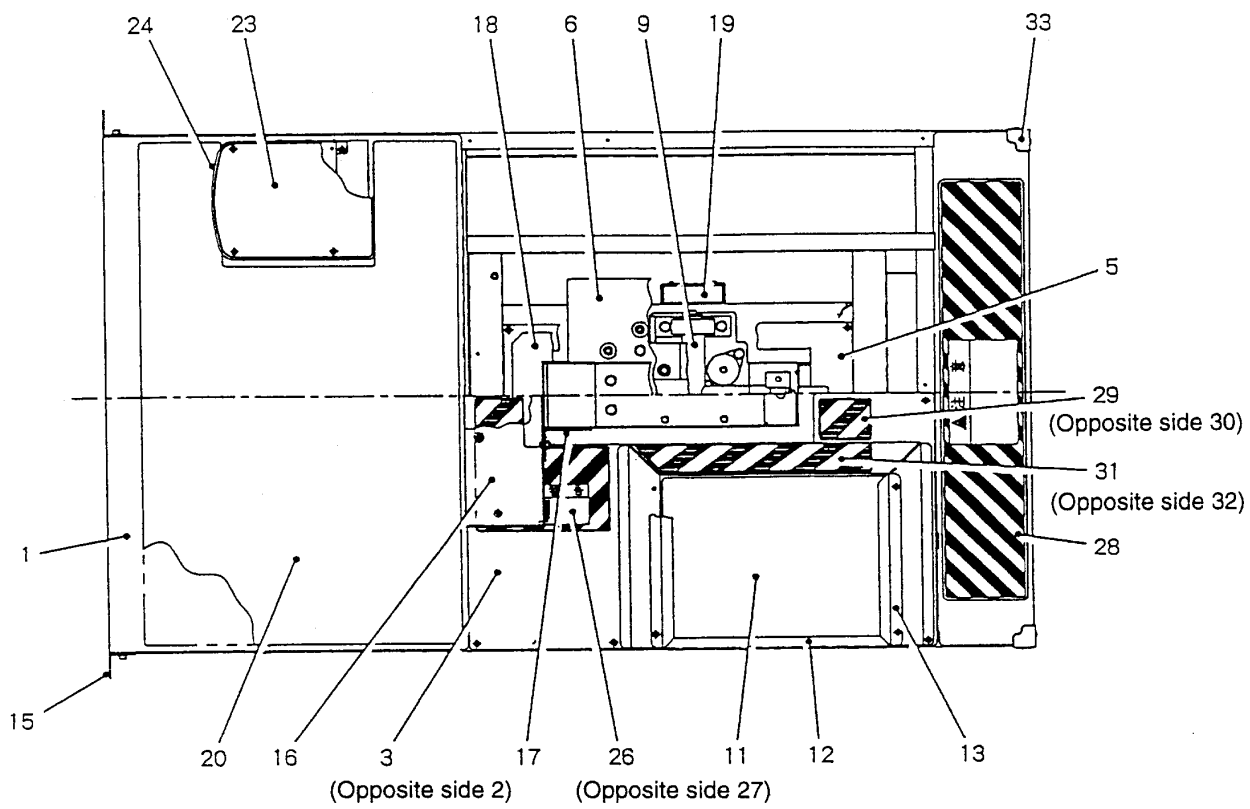

ITEM	DESCRIPTION	PART No
1	Main Base Metalwork	45000985
2	Base Step Right	45000986
3	Base Step Left	45000987
4	Coin Tower	45000988
5	Bike Base Surround	45000989
6	Bike Base	45000990
7	Bike Mounting Plate	45000991
8	Bike Rear Base Cover	45000992
9	Bike Rotational Shaft	45000993
10	Bearing Washer	45000994
11	Floor Mat	45000995
12	Floor Mat Closing Bracket 'A'	45000996
13	Floor Mat Closing Bracket 'B'	45000997
14	Instruction Decal Support Bracket	45000998
15	Cabinet / Base Joint Bracket	45000999
16	Bike Front Support Bracket	46000000
17	Bike Angle Support Bracket	46000001
18	Plastic bike Base Surround	39000305
19	Nylon Stop Blocks	46000002
20	Cabinet End Base Decal	40000349
21/22	Base Side Decal	40000351
23	Instruction Decal	40000352
24	Instruction Decal Backing	46000003
25	"Fork Here" Decal	40000072
26	Cabinet End Warning Decal - Left	40000353
27	Cabinet End Warning Decal - Right	40000354
28	Rear Warning Decal	40000355
29	Small Lined Warning Decal - Left	40000356
30	Small Lined Warning Decal - Right	40000357
31	Angled Warning Decal - Left	40000358
32	Angled Warning Decal - Right	40000359
33	Base Corner Piece	46000004
34	Rubber Stoppers KB-60-58H	46000006
35	Rubber Stopper RI-30	46000007
36	Adjustable Foot	88300079
37	Swivel Castor 75mm	59000005
38	Pillow Bearing UCP 205	46000008
39	Pillow Bearing UCPA 205	45000974

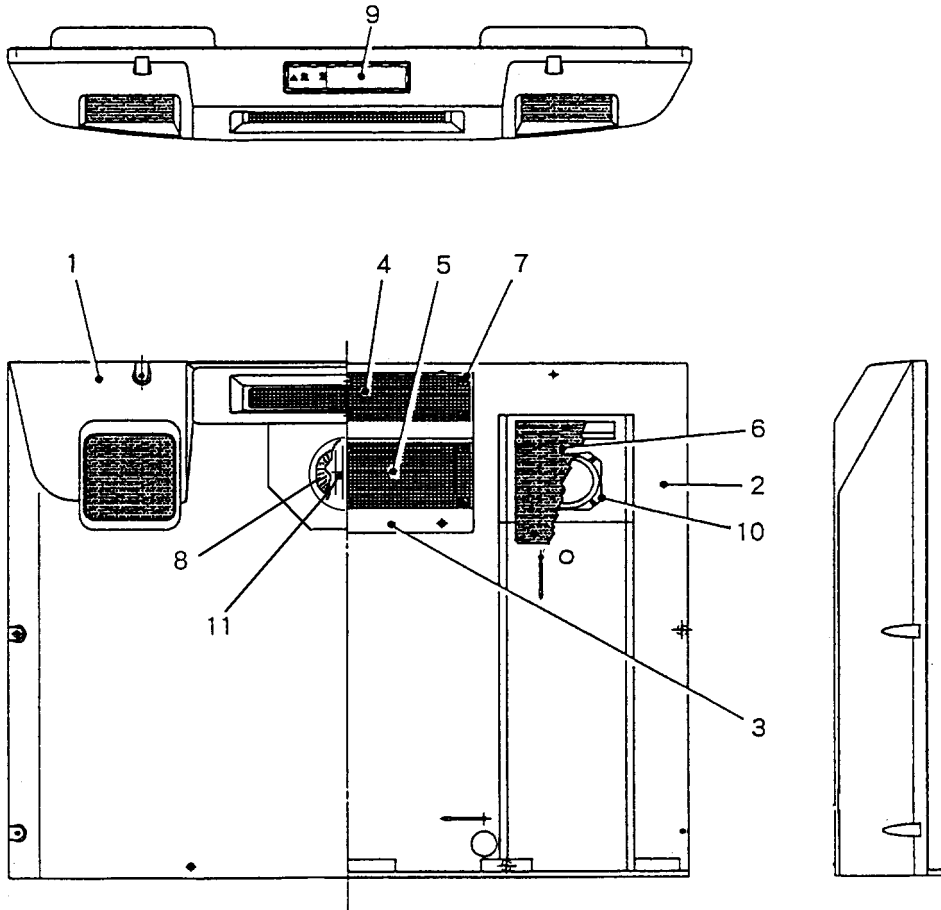

ITEM	DESCRIPTION	PART No
1	Fan Cover Vac-Form	45000934
2	Fan/Speaker Box Wood	37100099
3	Fan Cover	45000935
4	Top Fan Mesh	45000936
5	Bottom Fan Mesh	46000042
6	Speaker Mesh	45000938
7	Speaker Mesh Washer	45000939
8	Fan - Rotary	45000940
9	Fan Warning Decal	40000343
10	Loudspeaker 5½" Full Range - With Shield	62000073

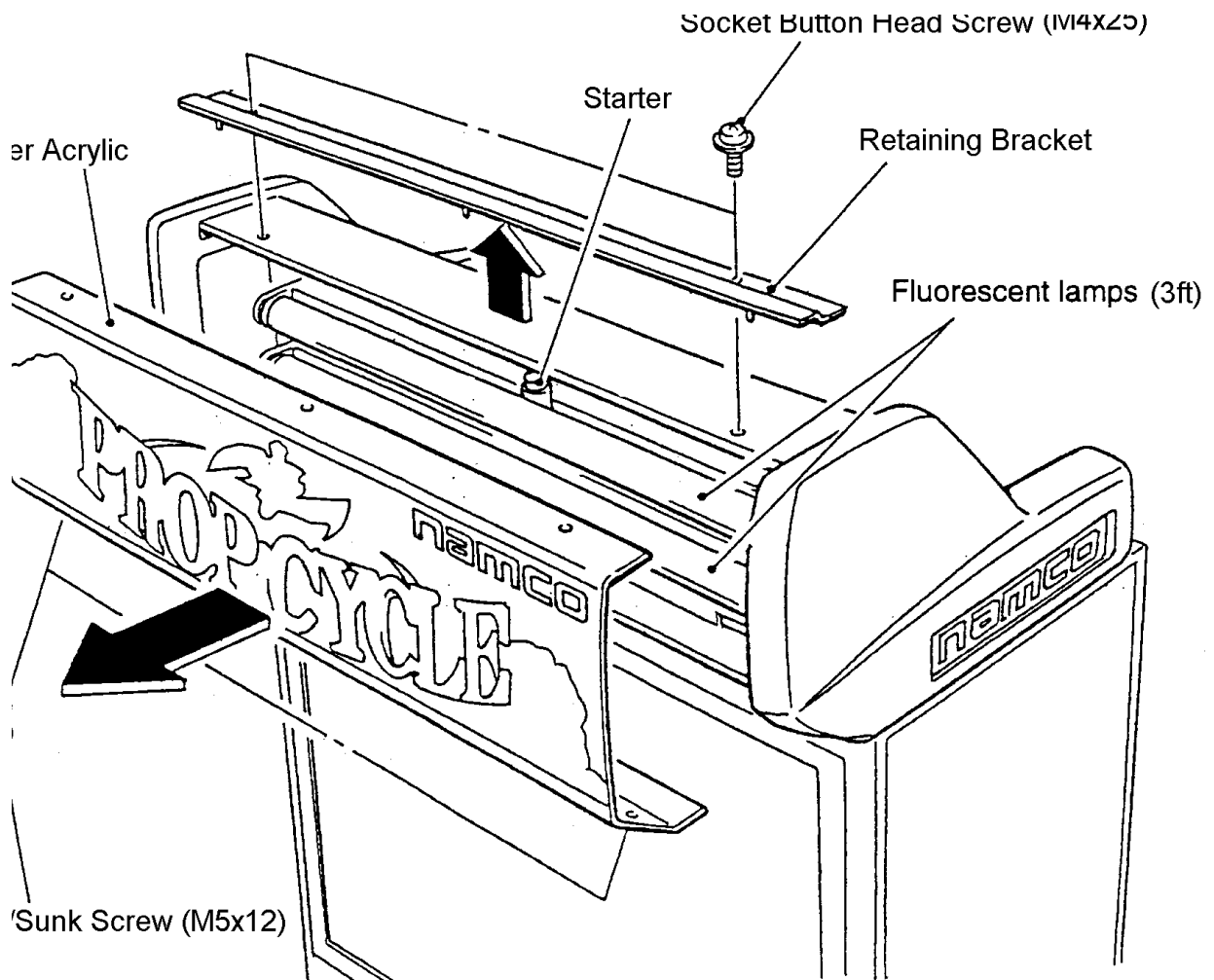

ITEM	DESCRIPTION	PART No
1	Header Wooden Housing	37100097
2	Fluorescent Tube 3ft	98000016
3	Header Acrylic Retaining Bracket - Upper	46000034
4	Header Acrylic	30000230
5	Header Vac-Form with Inset - RHS	45000932
6	Header Vac-Form with Inset - LHS	45000931
7	Header Vac-Form Decal 'NAMCO'	40000266

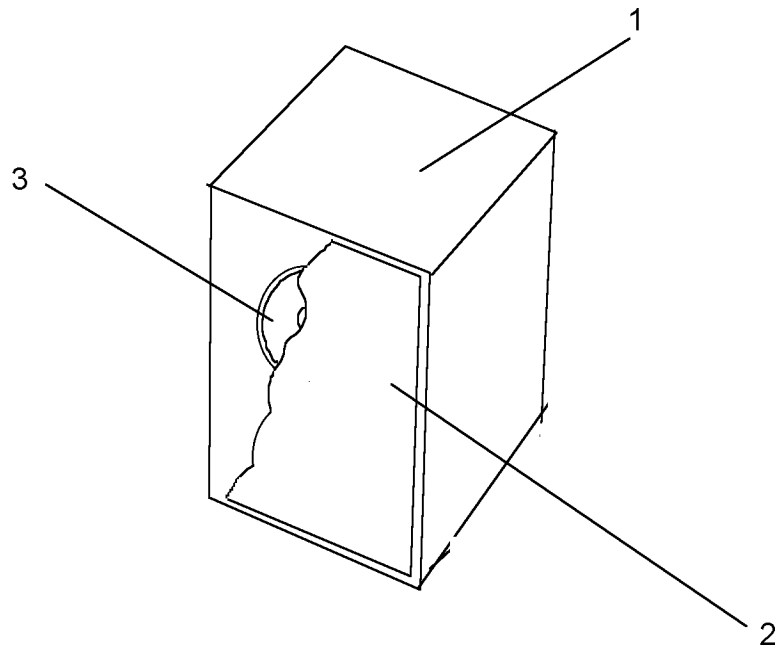

ITEM	DESCRIPTION	PART No
1	Sub Bass Cabinet	37100100
2	Sub Bass Cabinet Grille	46000035
3	Bass Drive Unit 6½"	62000068

9. SCHEMATICS

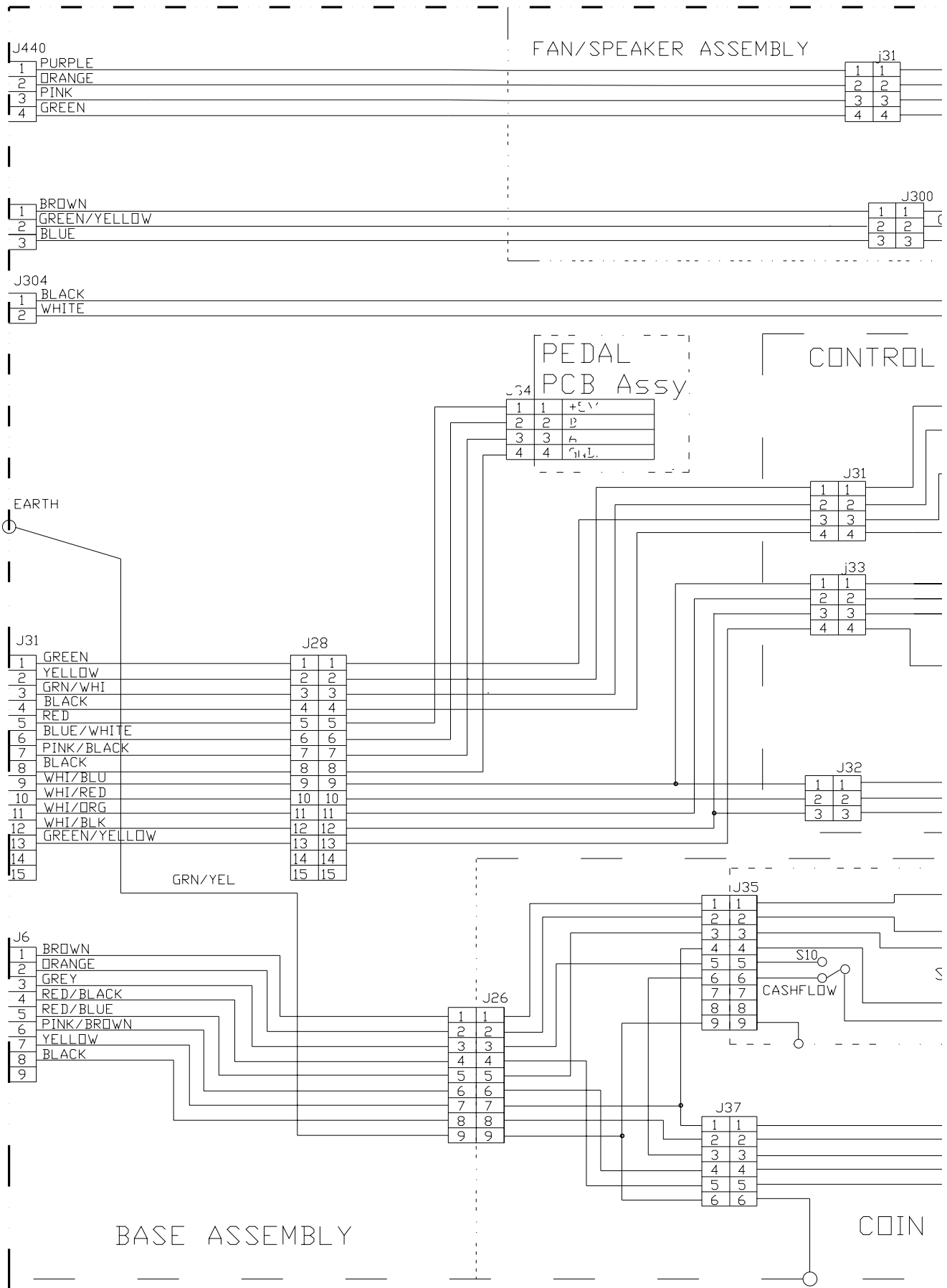

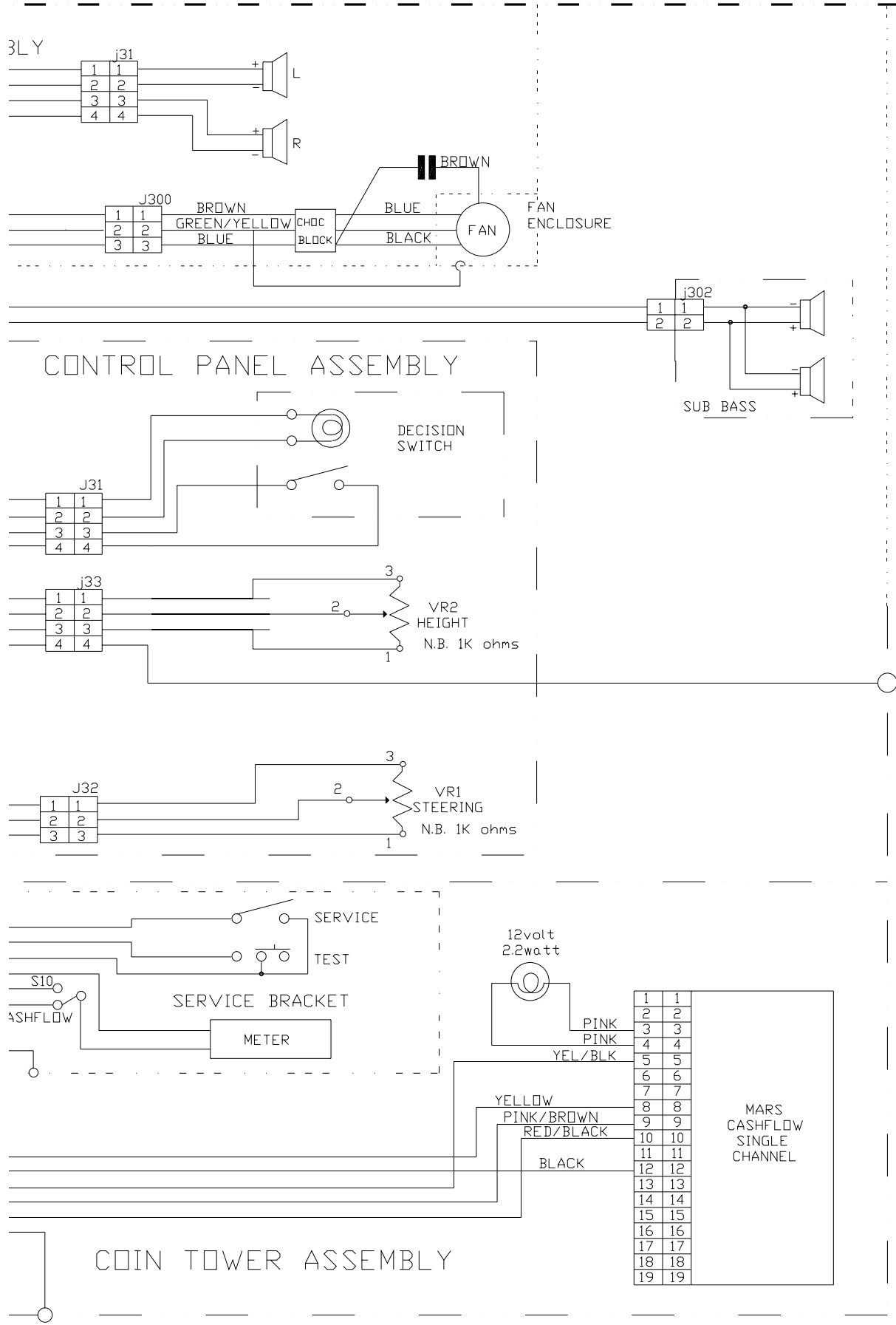

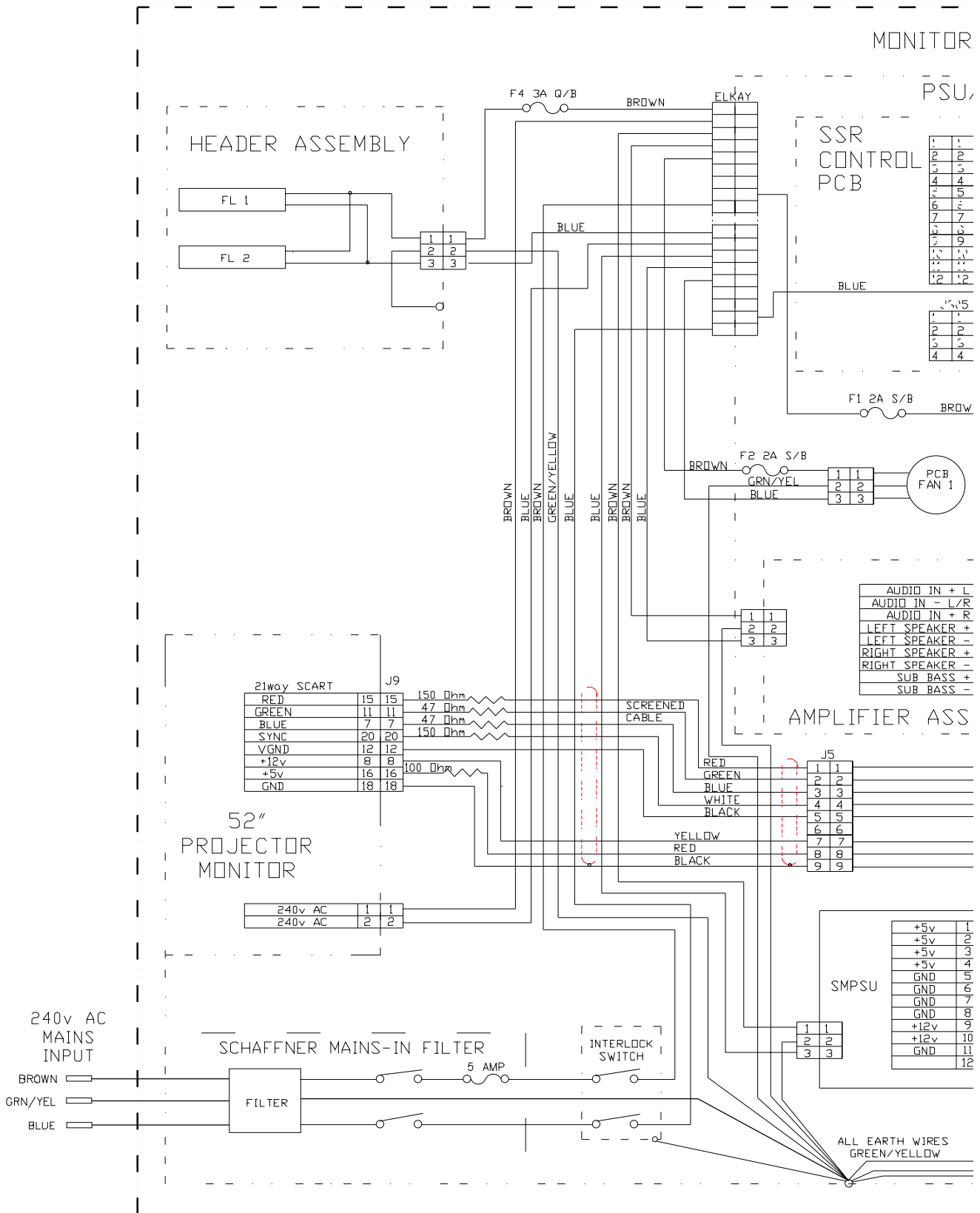

ITOR CABINET

PSU/PCB BOARD ASSEMBLY

